

# VOYAGES SF

#15 \$2.75  
\$3.25 in Canada



**MEGATRAVELLER™**  
Recruiting For Paradise

**2300 AD™**  
Ship Profiles

**BATTLETECH™**  
Idiots Don't Drive  
Battlemasters

**GURPS AUTODUEL™**  
Espionage Is Alive And  
Well In AutoDuel America

# KNIGHTFALL

## THE LOST LEGACY OF THE LONG NIGHT

Innocent traders run afoul of local politics and are caught up in the battles of the Rebellion itself. But that's just for starters! They become prisoners of war, then fugitives. Along the way, they learn of a fabulous pre-Imperium lost city of high-tech wonders. Can this city's treasures give one side the advantage that will win the Rebellion?

Eight successive scenarios,

plus assorted random nuggets that together make this a tense, exciting **MegaTraveller** adventure!

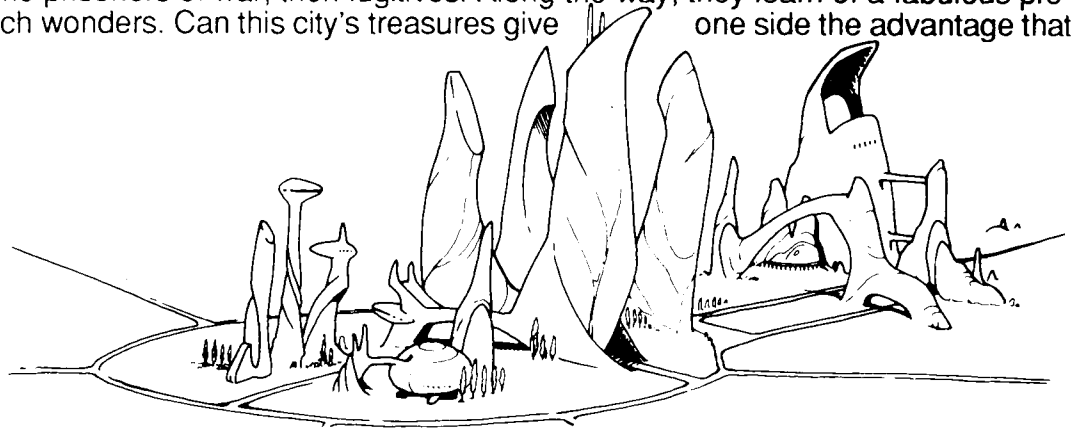

Here's an adventure to knock your characters' socks off! Start with an ordinary situation and gradually escalate the danger, the intrigue, and the clues until the only solution is at the end of a long, arduous journey. But that solution is impressive: a fabulous pre-Imperial city of undetermined (but very high) tech level. Somehow, long ago, it fell off the maps, and now only a trail of clues leads to its lost wonders.

Of course, the adventurers are pursued by agents from all sides of the Rebellion. Stopping even for a day can be hazardous to their health.

**Knighfall's** cinematic nugget system clearly defines and describes the incidents player characters will pass through in the course of their explorations. Careful detailing makes each nugget come alive for the players and referee.

**Knighfall.** A **MegaTraveller** adventure. 96-page book. GDW: 0219. ISBN: 1-55878-062-9. \$10.

### CINEMATIC NUGGET FORMAT

Each scenario is composed of several nuggets: Some are just for atmosphere, but others are identified as key nuggets that must be played.

Each nugget has a *scene* (information for the players on what they see, hear, taste, and feel at the start of the nugget) and an *action* (information to referee on how to run the action in the nugget). Each scenario has a referee's summary on the first page, with a brief description of each nugget by number. This summary includes a special synopsis diagram showing visually how the nuggets fit together.

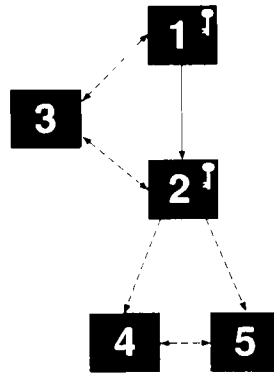

### Rebellion Sourcebook

The Imperium is being torn apart by the Rebellion; the once-stable 1000-year empire is rapidly decaying into dozens of petty princedoms. **Rebellion Sourcebook** covers every detail of the Rebellion: the sides, leaders, territories, fighting, equipment.

**Rebellion Sourcebook.** 96-page book. GDW: 0214. ISBN: 0-943580-63-3. \$10.

Look for GDW games at your local game or hobby store. If it doesn't have them, it can special order them. Write for our free, full-line GDW game catalog.

By mail, send a check, money order, or Visa/Mastercard number and signature. Please add 10% for shipping and handling. By phone, (309) 452-3632 between 9 a.m. and 5 p.m. Central time.

SINCE 1973

**GDW**  
GAMES

P.O. Box 1646  
Bloomington, IL 61702-1646

# WELCOME ABOARD

With this issue we begin our third year of publishing **Voyages SF Magazine**. None of our readers will argue that we have come a long, *long* way from **Jumpspace**, the amateur publication **Voyages SF** evolved from. And, with this issue, we move to a more mainstream magazine appearance, using a full-bleed cover. Will we ever be able to go to a full-color cover? We hope so. Publishing **Voyages SF** has been a struggle. There is a lot of competition in this industry, and, for small publishers, earning the support of the wholesale distribution network is never an easy task. And it's all a lot of work. But we enjoy it. Our current goal is a full-color cover and 48 pages. You see, we intend to publish **Voyages SF** for a long time to come.

Some of our readers will be aware that **StarLance** has moved on to the book publishing scene. While some of our books are of interest to genre fans beyond the realm of gaming, our May release, **It's A Gamer's Life**, is of interest to gamers. We hope you'll look for this one. It's great humor. We are especially looking forward to our July release, **Heroes Of Yesterday And Tomorrow**, as it features artwork from many of the game industry's top illustrators. We think you'll find this book quite useful in gaming, and a pleasant book to own because of the fine art quality.

— James B. King

## VOYAGES SF 13 SURVEY RESULTS

Words To Game By .....	3.5
Graphics & Illustration .....	3.4
Reviews .....	3.3
Encounter At Hesperus .....	3.1
Commlink .....	3.0
Gunsmiths In Star Wars .....	3.0
Solomani Space Fighters .....	3.0
Corsair Contention .....	2.8
Effects Of Wounds In Star Wars .....	2.8
The Go-Betweens .....	2.6
The Haunted Car .....	2.5
Combat Errata for Palladium RPG Systems .....	2.1

Q1: Is this issue better, the same, or not as good as our last? 50% said Yes, 50% said Same.

Q2: Including yourself, how many people read this issue? 2.0

Q3: Rating in order of preference the most recent issues of the gaming magazines you read, where would you rate this issue of VOYAGES SF (1 is high)? 2.5

---

**6 Recruiting For Paradise**  
A MegaTraveller adventure. The effects of hunger and disease are prevalent on Roup. For some, there may be a future... *James B. King*

---

**10 20th Century Air-To-Air Combat**  
Using the BattleTech/AeroTech system.  
*Gary A. Kalin*

---

**16 PREVIEW: Heroes Of Yesterday And Tomorrow**  
An advance look at StarLance's upcoming product release.

---

**20 Espionage Is Alive And Well In AutoDuel America**  
Details on espionage agencies and roleplaying secret agents.  
*Robert L. Collins*

---

**23 2300 AD Ship Profile and Size Chart**  
Build your own starship miniatures for playing Star Cruiser.  
*Don W. Shanks*

---

**28 Idiots Don't Drive Battlemasters**  
BattleTech fiction. "Some people actually go for these swarm tactics... but the tactic isn't worth drek." *Kevin Hodges*

---

**30 Reviews**  
Cadillacs & Dinosaurs, Central Casting: Heroes For Tomorrow, The Flaming Eye, Merc: 2000, Tramp Freighters, Infantry Weapons/World, USS Hampton, Armored Reserves

---

**5 Commlink**  
**22 Future Voyages**

---

**22 Voyages SF 13 Survey**  
**18 Words To Game By**

# VOYAGES SF

**Editor & Art Director:** James B. King

**Contributing Editors:** Glen Allison, Jerry Campbell

**Distribution Manager:** Chantelle King

**Artists in this issue:** Rob Caswell (17); Jim Garrison (18); Kevin Hodges (28); Gary A. Kalin (cover, 10, 11, 12, 15); (13); James B. King (16); Phil Morrissey (19); Blair Reynolds (17); Don W. Shanks (24, 25, 26, 27); Richard Tomasic (7, 16); David L. Transue (17).

**Trademark Notice:** Most games are trademarks of the companies publishing those games. Use of a trademark to identify a product commented upon in this magazine should not be construed as implying the sponsorship of, nor challenge to, the trademark holder.

**Voyages SF** copyright 1991 by James B. King. All rights reserved. Printed in the U.S.A. **Voyages SF** is published quarterly by StarLance Publications. Cover price is \$2.75. A four-issue subscription is \$10.00 (\$11.00 to Canada). All funds must be in U.S. dollars. Mail to StarLance Publications, 50 Basin Drive, Mesa WA 99343.

**Advertising:** For rates and space reservation or confirmation, contact James King at the address above or call (509) 269-4497 after 6:00 pm or on weekends.

**Submissions:** We welcome unsolicited manuscripts and art. However, before submitting you should write and request a guidelines sheet, including a self-addressed, stamped envelope (SASE). Also include a SASE or post card with correspondence to assure a response.

### Distribution to retailers by:

Action Direct Dist., The Armory, Capital City Dist., Chessex, Diamond Comic Dist., Heroes World, Styk International, Wargames West, Zocchi Dist.

### Advertisers:

Anarchy By Mail (8)  
Digest Group Publications (4)  
Game Designers' Workshop (inside front cover, 9)  
Gemco (8)  
Seeker Gaming Systems (inside back cover)  
StarLance Publications (Back cover, 19)  
Sword & Starship Enterprises (15)

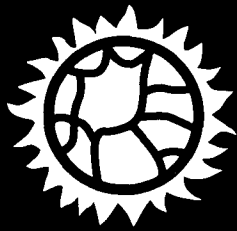

# MEGATRAVELLER

THE SCIENCE FICTION ROLE-PLAYING GAME FOR THE '90s AND BEYOND

## THE FLAMING EYE

A treasury of background information and scenario ideas guiding you through two detailed campaigns set in the Restored Vilani Empire. Abounding with new starmaps, world data sheets, and Far Trader deckplans. 104 pages. Price: \$12.95.

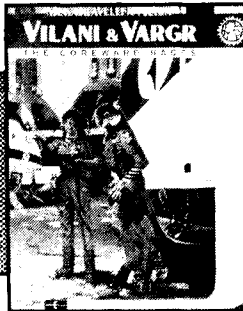
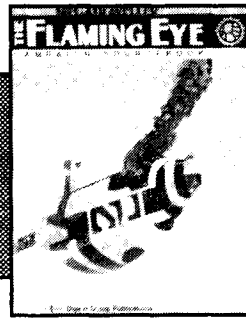

## VILANI & VARGR

The first volume in the new series on the aliens of *MegaTraveller's* universe, this product covers two of the game's major races. Includes details on technology, culture, astrography, and much more. Experience these races as you never have before! 104 pages. Price: \$12.95

## STARSHIP OPERATOR'S MANUAL

Detailing operations for both the player and referee, this 64-page book discusses all the technical details of starships in the *MegaTraveller* universe. Includes an illustrated tour & fold-out plans for the 200-ton free trader; plus many useful diagrams and charts. Price: \$8.95.

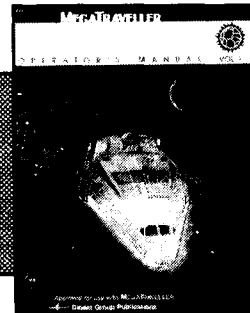

## 101 VEHICLES

An illustrated compendium of 101 different vehicles, ranging from the largest hypergrav transports to one-man motorcycles. Each vehicle is fully illustrated and described, with six of the craft in full color. 48 pages. Price: \$7.95.

### ALSO AVAILABLE:

- **THE MEGATRAVELLER JOURNAL Magazine:** Packed with lots of new *MegaTraveller* material in each 96-page issue. Topics include new equipment, ship designs, library data, Rebellion era news, maps, adventures, new rules, Q&A column, and more! Single issues \$12.95.



Ask your local dealer for these products or order direct:

(P&H: \$6% [\$2 Min.] U.S. and Canada/ 30% Airmail [\$5 Min.] or 15% 6-8 wk. delivery [\$3.50 Min.] Overseas)

 **Digest Group Publications**

515 Willow, Woodburn, OR 97071  
Voice or FAX: (503) 981-4752

# commmlink

Publishers desiring more informative write-ups of their releases should send advance announcements and/or product samples.

Question mark indicates release date unknown. Parentheses indicate intended release date. Dates not in parentheses indicate item available at preparation of this column.

**The Adjutant**  
**MegaTraveller:** Orbital Assault Vehicles, \$4.95, ? Exotic Vehicles, \$4.95, ?

**Chaosium**  
**Call Of Cthulhu:** Dark Designs, \$18.95, Mar  
Return To Dunwich, \$18.95 (Apr)  
Keeper's Kit, \$14.95 (Apr)

**Digest Group Pub.**  
**A.I. - Role Playing in a Technofantastic Age:** Nanotechnology, artificial intelligence, and genetic engineering all combine to produce one of the most fresh new gaming backgrounds on the market. "Not technology and magic, but technology *as* magic!" Cover & interiors: Mike Vitardi (October).

**MegaTraveller: Alien Vol. 2 - Solomani & Aslan:** The second book in DGP's rewritten and expanded coverage of the major alien races. Interior art: Mike Vitardi & Blair Reynolds. Cover: Dell Harris. 104pp. \$12.95 (Summer)

**Onnesium Quest - The Antares Campaign Sourcebook:** Similar in format to *The Flaming Eye*, this adventure/sourcebook brings your players across the Antares region on a quest for the ultimate treasure. Cover: A.C. Farley. 104pp. \$12.95 (Late '91).

**MegaTraveller Journal #3:** Now almost twice the size! Loaded with all kinds of informative and useful MegaTraveller material. 104 pp., \$12.95 (Late '91).

**DSI**  
**Time Drifters:** Wild West Time Travel, \$14.95 (Apr)

**FASA**  
**BattleTech:** Record Sheets #2: Med Techs, \$8 (Apr) Record Sheets #3: Heavy Mechs, \$8 (May) Map Set #3, \$15, Feb Map Set #4, \$15 (Apr) Rhonda's Irregulars, \$8 (Apr) OmniTech Blueprints, \$10, Feb

Technical Blueprints (box), \$10, Feb

**Renegade Legion:** Guide to Shannadam County, \$12, Mar  
**Tessdrake Run,** \$8, Mar  
**Shadowrun:** Dragon Hunt, \$8, Jan  
Neo-Anarchist's Guide to North America, \$15, Mar  
Virtual Realities, \$15 (May)

**Flying Buffalo**  
**MSPE:** Mug Shots, \$8.95, ?

**GDW**  
**Twilight: 2000:** NATO Vehicle Guide, \$12 (May)  
**Merc: 2000:** Gazetteer Sourcebook, \$12 (Apr)

**GMA**  
Interstellar Elite Combat RPG, \$30 (May)

**Games Workshop**  
Advanced Space Crusade (boardgm.), \$54.95, Jan  
Battlefleet Gothic Boardgm., \$47.95 (Apr)  
**Warhammer 40,000:** Marine Codex, \$24.95 (Apr)

**Hero Games**  
**Champions:** Alien Enemies, \$12, Jan  
Olympians, \$9, Mar

**Iron Crown Ent.**  
**Cyberspace:** Chicago Archology, \$20 (Apr)  
**Star Strike:** Miniatures Rules, \$7, ?

**Leading Edge**  
Aliens RPG, \$21.95 (Apr)  
**Phoenix Command:** Heavy Metal Powered Armor, \$12 (May)  
Rhand: 2349, \$11.95 (Apr)

Advanced Damage Tables, \$8.95 (Apr)

**Mayfair Games**  
**DC Heroes:** Atlas of DC Universe, \$20 (May)  
**Chill:** Lycanthropes Sourcebook, \$12 (May)

**Palladium Books**  
**Recon:** Navy Seals, \$9.95 (Summer/Fall)  
Desert Recon, \$14.95 (Summer/Fall). Covers two decades of military conflict in the middle east. Includes a variety of adventures and new rules.

**Rifts: World Book 1: The Vampire Kingdoms.** Approx. 160 pp. \$14.95 (Late May). A detailed look at vampires and their hideous society. Crazed vampire hunters as evil as the monsters they stalk. Additional monsters; many are optional player characters. Maps, towns, and cities of Central America. Adventures, adventure ideas, and source material. By Kevin Siembieda. Cover and interiors by Kevin Long.  
Rifts Sourcebook, \$14.95, Mar  
The New West, \$14.95 (Apr)  
Invid video #2, \$29.95, Mar  
Invid video #3, \$29.95, Apr  
Invid video #4, \$29.95 (May)

**R. Talsorian**  
**Cyberpunk:** Cyberpunk 2020 Rulebook, \$20 (Apr)  
Data Screen/When the Chips are Down, \$10, Feb  
EuroSourcebook, \$12 (Apr)  
Miniatures-Cyberpunk Characters, \$10 (Apr)

From Palladium Books' Rifts Sourcebook



**SGS**  
**2300AD:** USS Hampton (25mm Plans), \$11.95, Mar  
**MegaTraveller:** Gazelle Close Escort (25mm Plans), \$11.95 (Apr)

**Starchilde Pub.**  
Guardians RPG, \$9.95 (Apr)  
Freedom Union Adventure, \$4.95 (Apr)

**Justifiers:** Cybermedtech Sourcebook, \$8.95 (Apr)  
Silent Corporation, \$9 (May)  
**Japanese Movie Monsters:** Monsters, \$14.95 (Apr)

**StarLance Pub.**  
It's A Gamer's Life, \$5.50 (May).

**Heroes Of Yesterday And Tomorrow.** 48 pp. \$7.95 (July). A collection of full-page character studies of both fantasy and science fiction characters, useful as both player and non-player characters in roleplaying. Includes favorite artists Rob Caswell, Liz Danforth,

David Deitrick, Blair Reynolds, and Richard Tomasic

**Stellar Games**  
**Knightlife:** Magic, Witches, Etc., \$12.95, Jan

**Steve Jackson**  
**Toon (New Edition):** Deluxe Toon, \$19.95, ?

**Task Force Games**  
**Starfleet Battles:** Captain's Rulebook (box), \$44.95, Mar  
Advanced Missions, \$30 (May)  
New Worlds I, \$15 (May)  
New Worlds II, \$15 (May)

**Tri-Tac Systems**  
Fringeworthy RPG, \$18 (May)  
**Stalking Night Fantastic:** Hell's Night, \$12 (May)  
Haunts, \$12 (May)

**TSR**  
**Buck Rogers XXVc:** Deimos Mandate, \$6.95 (Feb)  
Character Record Sheets, \$8.95, Feb  
Inner Worlds Accessory (25CR3), \$9.95 (Apr)  
A Matter of Gravitol, \$7 (May)  
**Marvel Super Heroes (New Edition):** New Basic MSH, \$20 (Apr)  
X-Terminate, \$7 (May)

**West End Games**  
**Paranoia:** Extreme Paranoia (novel), \$5 (May)  
**Star Wars:** Miniatures Rules, \$15, Apr  
Galactic Races (miniatures), \$12 (May)  
Zero-G Assault Troopers (miniatures), \$12 (May)  
**Torg:** Pixaud's Practical Grimoire, \$15 (Apr)  
Full Moon Draw, \$12, ?  
Nippon Tech Sourcebook, \$18 (May)

From Palladium Book's The Vampire Kingdoms



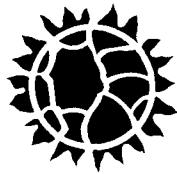

# MEGATRAVELLER

## RECRUITING FOR PARADISE

James B. King

### Introduction

This adventure takes place on the planet Roup in the Regina Subsector of the Spinward Marches (2007-C77A9A9-7, S Hi In Wa, A323lm, F9 V). Alternatively, it could be played on another high population world with a few adaptations, though such a world should be suffering the ills of massive overpopulation. For additional information on Roup see "Foodrunner" in JTAS Vol. 2.

The adventure is written to allow extensive use of Interpersonal and similar skills. Getting the player characters to Roup is left to the devices of the players and/or the referee.

### The World Of Roup

Roup is a water covered world with a tainted atmosphere. The only land masses are the peaks of an extensive under water mountain range. Built upon these peaks are the cities which house the teeming masses of the planet's billions of citizens.

The atmospheric taint is a substance that is a moderate irritant to human lungs. However, longtime citizens have adapted to the substance and do not require filter masks, though visitors to the planet do require them. Most port and government buildings contain atmospheric "scrubbers" to filter the air, so filter masks are not required in such places.

The people of Roup are currently suffering from food and medicinal shortages (virtually all needs are not being met, but these two are life threatening) brought on by the shipping collapse that resulted from the Vilani megacorporate consolidation to Vland. Because of the desperation of the people, an opposition organization calling itself the United People's Front has gained enough support to challenge the leadership of the planet's dictator, who is simply referred to as the "Leader." The UPF has continually called on the Leader to step down and allow a new government into power — the new government being the UPF leaders. The UPF has successfully smuggled weapons and explosives onto the planet. As the UPF is largely made up of radicals and extremists, it is feared to just what extreme they will go to in their stated goal to reduce the population of Roup.

### Arrival

After the PCs land their vessel at the small, open field port and while they tend to the business which brought them to Roup (they may

very well be transporting luxury foodstuffs) they observe the current situation on Roup. Massive numbers of people are to be seen everywhere. Much of the populace obviously lives in dismal poverty. Many live in the streets. The effects of hunger and disease are visibly prevalent, especially among the street people, and depression and desperation are easily read in their faces. Quarreling and fighting are rampant, and police, who actively patrol in groups of no less than four troopers, respond harshly to outbreaks of violence with liberal application of clubs and stun batons.

Conversation with citizens reveals that the people of Roup have faced serious shortages of food and medical supplies. While the world's food needs are provided for by processing the plentiful sea life into food concentrates, the continuing civil war has resulted in serious deficiencies in shipping volume to Roup, primarily due to the shipping collapse brought on by the pullout of the three Vilani megacorporations. The lack of sufficient shipping has resulted in an inability to mechanically maintain food processing plants and distribution networks. Food supplies are often short of adequate and exports of emergency rations to the Regina Subsector Navy have dwindled to nothing.

### Rumors

The rumors below should be presented in a way that they are indicative of the level of fear and despair among the poor masses.

1. The government is preparing a plan to forcefully sterilize the poorer classes of citizens.
2. Instead of cremating the deceased, the government has secretly begun processing large numbers of corpses into food concentrates.
3. The United People's Front, the only hope of many of the poor, has become a force to be reckoned with. But now, influential people who have spoken out in support of the UPF are disappearing.
4. Radicals are abducting young women off the streets and forcefully sterilizing them before releasing them.
5. The government is secretly financing and advising a radical movement that is murdering elderly and invalid citizens.
6. Luxury foodstuffs are being secretly imported by the upper classes by way the Imperial Scout Base.

### Perfect For The Job

The PCs are approached by an attractive red-haired woman, Beverly Warren, who introduces herself as a representative of the Branstetter Foundation, an organization operating across much of the Marches and headquartered on Regina. The foundation works to assist developing worlds in dealing with unique difficulties involving their environments. The foundation maintains offices on Roup under contract with the government to assist them in dealing primarily with the problem of massive overcrowding. Miss Warren offers the group employment in an operation to relocate off planet a large number of people. The group are obviously well traveled and, more importantly, from off planet.

Miss Warren wants the group to recruit labor colonists among the poor and the homeless of the streets to go to Treece, in the Lanth Subsector, where they will work in mining complexes owned by Monteilh Mining and Resource Co., which is largely owned by Sternmetal Horizons, LIC (who, incidentally, is the contractor who installed the food processing plants on Roup). The foundation will pay each PC Cr100 per day plus a bonus of Cr10 for each laborer 18 or older signed up by contract. The specifics of the recruiting contract are below:

1. Laborers and family members will be transported free of charge by sub-middle passage (aboard decommissioned military transports) to Hyrkas, a small planet in the Treece system which is owned by Monteilh.
2. All family members age 18 or older must agree to a labor term of ten years (necessary because of the exorbitant costs of transportation to the planet and setting up households).
3. Instead of a wage, all domestic needs, to include food, housing, medical, educational, child care, clothing, and entertainment will be provided for all family members.
4. Upon completion of labor term, each laborer will receive severance pay of Cr25,000 plus one free middle passage.

Miss Warren informs the PCs that the foundation is working with Monteilh to provide work and a higher quality of life for about 300,000 labor age citizens of Roup. With the families, they expect to move 750,000 people. If the players express suspicion about the contract, she shows the PCs seemingly endless photos of starving, emaciated people, many of them young children; near dead elderly people just lying in the street;

young people murdered for a mouthful of food. "Now tell me this contract isn't helping these people," she says sternly.

Miss Warren provides the PCs with contracts and brochures to hand to prospective colonists. When contracts are signed, the family has up to three days before they must report to the foundation's offices for preparation for transportation. The brochure touts the benefits provided to families — which will make Hyrkas appear as a paradise to the desperate masses of Roup. Miss Warren strongly suggests that the PCs claim to have been to Monteilh's complexes on Hyrkas and vouch for the accuracy of the brochure. Smiling, she nods her head and states, "Yes, it may be telling a lie, but your recruitment will be more effective, and in the end you, Branstetter, and Monteilh will be able to help more of these poor unfortunate people."

## Recruiting For Paradise

The PCs are just one group of many who have been hired by Miss Warren. As the PCs go out each day, have each player roll the following task once per hour spent recruiting to determine the level of their success:

To determine recruitment success:

Simple, Recruiting *or* Persuasion, Int, absolute-1 hr (unskilled OK).

*Referee:* If the task roll is successful, the task result (including DMs) is the actual number of contracts filled out and signed. On Exceptional Success, multiply the task result by two. A mishap indicates that the recruiter has angered a prospective contractee. The referee should role-play such incidents as desired.

## Recruiting Encounters

Below are three encounters. Apply them in order, one each day. You may wish to apply other encounters as well, such as street thugs who intend to rob the characters or the daily food truck that drops its load in the streets, creating a virtual war zone as people struggle to get their share.

**1. The Starving Family:** A young mother with three children, all under five years old and one only a small infant, approaches the group with her children in tow, drawn to the PCs by their dress and the fact that they wear filter masks, as they are obviously from off planet. The woman is rather smallish, with long black hair, and is pretty, though dirty. She would likely be a beautiful woman if she did not bear the scars of hunger and want. She and her children are dressed in filthy, tattered cloths. They are beginning to show the grim signs of malnourishment: exhaustion, loss of bulk, and thinning arms and legs. They all stare at the PCs through slightly bulging, desperate eyes.

"Please, sirs. Please, will you help us?" she pleads, reaching an empty, trembling hand out to them, holding the bleary infant in the other. "We haven't eaten well for so long. The trucks come through every day dropping food in the street, but I can't —" The woman's voice starts to tremble, and tears flood her eyes. "I'm alone. My husband is gone. We have to fight with the street people for every scrap of food. I just can't get enough to feed my child—" Her voice falters. Her eyes widen, her face twisted by despair. In a voice wracked by anguish, she cries, "My children are starving and I can't stop it from happening! Please, please help us!"

The players should be moved to aid this particularly needy family. Even if she signs a contract, the family has immediate needs. How they choose to help should be left up to the players.

**2. The Terrorist:** During their recruiting, the PCs approach close to a chemical processing plant which takes in highly toxic chemical wastes which are generated by the operation of the food processing plants. The wastes are solidified then fused inside blocks of glass. The blocks are then safely stored in containment facilities under the ocean's surface.

The PCs hear a commotion somewhere behind them. Several people are yelling. As the PCs watch, a man runs toward them, chased by several armed police troopers. Just before the pursued man reaches them, the jacket he's wearing opens up to reveal a hefty amount of explosives strapped to his body. At that moment fully automatic weapons fire pelts the area where the troopers are, striking two of them down. Whoever is pulling the trigger is not at all concerned about the innocent bystanders, and nine other persons are struck by the wild fire. The crowded street erupts in chaos as screaming, shouting people attempt to escape from the slugthrowers. Many people are knocked to the ground and trampled, some suffering serious injuries. The players should be caught in this onslaught of bodies. Have them roll a task to avoid being knocked down and trampled.

Hopefully the PCs intercede to apprehend the man carrying the explosives. If they do, make a big deal out of the man's fighting to reach the small box attached to his belt. If the PCs let the man pass, an enforcer gets off a lucky shot and drops the man only twenty meters from the outer wall to the chemical processing plant. The wounded man reaches to the box on his belt and the whole block is rocked by a massive explosion (you may wish to expose the PCs to possible injury from debris). At least a dozen people are killed and four times that many are injured from the blast.

As there are many wounded persons, the PCs may choose to apply medical skills in their care. They will hear much conversation about the amount of "toxic wastes that would have been thrown into the air if the terrorists had succeeded — why, there's no telling how many people would have died!"

The terrorist gunman escapes, slipping away in the confusion.

**3. The Old Woman:** Up to this point, the players should have been impressed just how desperate life has become on Roup, especially for the poor. Though they may have been suspicious of the contract, they should now believe that it has to be better than what the poor now suffer. This encounter will shatter that assumption.

On the third day, an older woman who wears a badge that identifies her as a social worker stops to listen to what the PCs are saying to some prospective colonists.

"How dare you take advantage of these

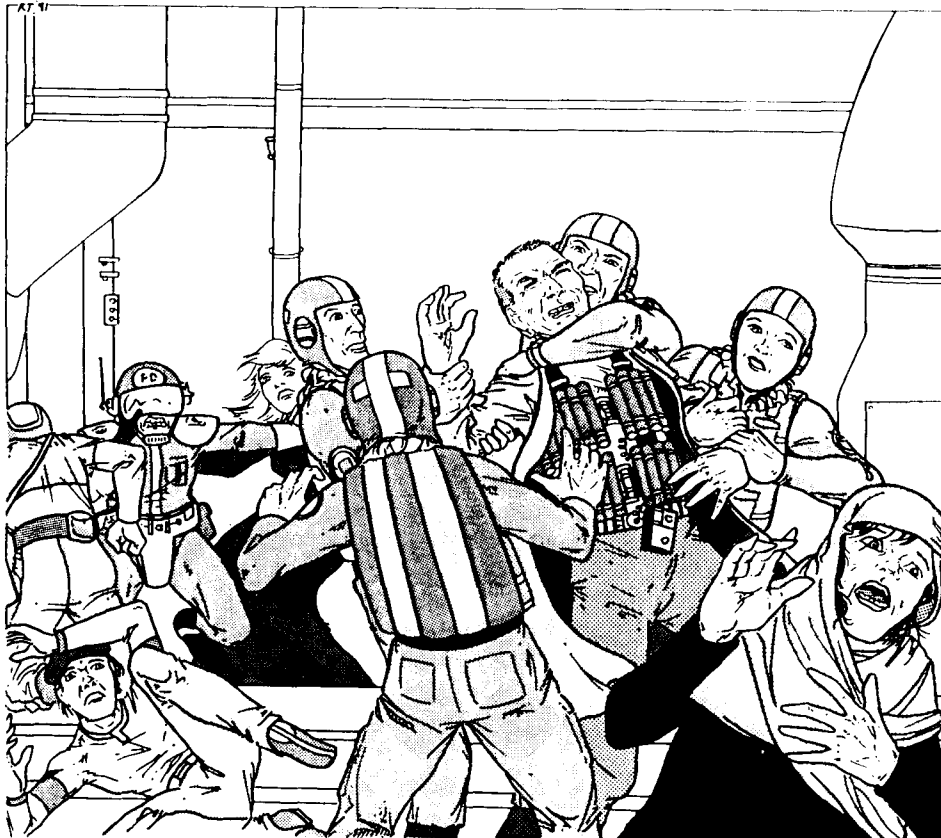

people!" she cries suddenly. "How dare you lie and mislead them! I've been on Hyrkas. I served ten years of virtual slavery in Monteilh's mines!" People quickly gather around. Soon hundreds of people are listening to the woman. "I signed this same contract when I lived on Enope. We were poor. They claimed they were helping us. Bah! My husband died there. My two children are still slaving away there in unsafe working conditions, working fourteen hours a day, ten days straight before they get just one day off. Oh sure, they provide all these things they claim to, but just barely. What they don't point out is that, when your children turn 18, they stop providing for them — nothing, not even food. And since laborers don't get an actual wage, they can't get their children off Hyrkas and out of Monteilh's clutches. Their only choice is to sign a ten year contract." The woman thrusts an accusing finger at the recruiters, glaring vehemently at them. "That's how they're 'helping' you. Don't let them do it! Don't let them take advantage of you!"

The crowd erupts. The word is quickly spread and within minutes thousands of people are rioting. In tens of minutes tens of thousands are rioting and looting. Armored police troopers turn out to combat the rioters with live ammunition as the violence continues to escalate.

The PCs will certainly want to get off the streets. Wherever it is they go, the referee should apply several tasks to avoid violence on the street, as the recruiters may very well be attacked by angry citizens. It may be very effective to have them witness the brutal murder of another recruiting team by overzealous street people.

Before the PCs get to wherever it is they're going, they are intercepted by police. All offworlders are being escorted (by force if necessary) to a military base for their own safety. The port is a bloody battleground and is completely sealed off due to the assault of enraged radicals. It quickly becomes apparent that the UPF has chosen this moment to rise in rebellion, fomenting the already enraged street citizens to rise up and destroy the government.

## Mediators Of Crisis

Several hours after the PCs arrive at the base, they are escorted to an office complex and ushered into a large but austere conference

room. Already seated at the table is Beverly Warren plus two men who Miss Warren introduces as Mr. Panerio and Mr. Gust. Panerio is Monteilh's top liaison on Roup. He is quite young and has a rather pompous and self-important attitude. Gust, an aging man, is the Director of the Dept. of Health and Welfare. He is not at all pleased by the events that have transpired. He tries to shift all responsibility to Branstetter and Monteilh, verbally accusing them of the treachery that has caused the rioting, but Panerio callously reminds Gust that he was well aware of all the specifics of the operation.

While Beverly Warren was aware of Monteilh's labor conditions, she had convinced herself that she was still helping the poor of Roup. But now she realizes that the whole operation is a loathsome plot against the poor. With a dejected expression she speaks to the PCs. "Some moderates within the UPF have come to us. They have expressed a belief that the ideals of their current leadership go too far — are too radical. And they see this colonization effort as one worth pursuing — if the contract can be negotiated fairly. If we negotiate a fair deal, they will usurp control of the UPF and stop fomenting revolt. It is the street people who will suffer if they do not." A look of pleading and sorrow clouds her face. "What we did was wrong. Surely we owe it to these people to offer them a real life — a future for their families!"

Panerio flashes Miss Warren a quick glare, then settles his stern gaze on the PCs. "We are willing to negotiate. However, these UPFs refuse to negotiate directly with representatives from Branstetter, Monteilh, or the government." He points his finger at the PCs. "You will negotiate between us. They claim they have a list of demands. We will start there."

The PCs are directed to an office down a hall where they find three men waiting for them. They are Mr. Veldman, Mr. Haner, and Mr. Kobata. Kobata will negotiate for the UPF.

After introductions, Kobata hands the PCs' chosen spokesman a list of demands. They are shown below. The text in parentheses is Monteilh's current policy.

- No minimum term of employment. (Ten year employment term.)

- A half standard wage of Cr10 per hour plus severance pay of Cr25,000. (No wage. Severance pay of Cr25,000.)
- A five day work week with two days off. (Ten hour work week with one day off.)
- An eight hour work day. (Fourteen hour work day.)
- Improved safety practices and conditions, inspected by an outside agency. (Limited safety concerns. No outside inspection.)
- Improved domestic needs in the way of food, housing, medical, education, child care, clothing, and entertainment. (Minimal domestic needs only.)
- Upon turning eighteen, children to have the option of a free middle passage to leave the planet. (Children forced into ten year contract.)

## The Negotiations

Obviously, the PCs have their work cut out for them. The first step is to go to Panerio for the first negotiation task. Take each of the above items one at a time. Use a separate task to hammer a deal through for each. Note that each item must be successfully negotiated between both parties. If one agrees to a deal but the other refuses it, the deal's out the window and they must attempt the task again with a new deal. The Difficulty Level should reflect how much give and take the players use. For instance, if the the PCs try to negotiate a wage of Cr7, the task will be Difficult with Panerio but Simple with Kobata. Negotiating a wage of Cr5 would be Routine for both. (Stats for Panerio and Gust must be generated. Both should have Liaison skill to be negotiators.)

## A New Contract

When a deal is finally hammered through, the UPF leaders are as good as their word. They apparently wrest control of the UPF from the extremist hierarchy and use their influence to help stop the rioting and looting. Word quickly spreads that a fair and rewarding contract has been negotiated and people come flocking to sign up. As it turns out, recruiters are not needed, so the PCs are out of a job. They should, however, receive a cash reward for their mediation, the amount to be determined by the referee. ■

## ANARCHY BY MAIL presents GALACTIC ANARCHY

A PBM Game of Galactic  
Exploration and Conquest.

100% Computer Moderated.

Set-up and first five turns are  
\$10. \$2.50 per turn afterwards.

Anarchy By Mail, P.O. Box 873,  
Allen TX 75002

# Origins '91

The National Gaming  
Convention and Exposition

July 4-7, 1991

Baltimore Convention Center

gemco

PO Box 609, Randallstown, MD 21133



The New

# TWILIGHT:



# 2000™

War has raged on for years. The front lines sweep back and forth across the ravaged face of Europe. The high-tech ammunition is dwindling. The high-tech equipment is failing, piece by piece, as spare parts and maintenance time evaporate before the march of an endless campaign. The front lines are now held by a few grim and desperate soldiers.

The U.S. Fifth Division has tenaciously held the line in central Poland. Now, a Soviet encirclement has cut it off in a region ruled by ambitious warlords, local militias, and bands of marauding deserters. Headquarters is 200 kilometers to the rear and helpless. Your last order sets you free...

**Good luck.  
You're on your own.**

**Twilight: 2000**—the roleplaying game of World War III.

**Characters:** Nationalities, new career types, skills, characteristics, military and nonmilitary backgrounds.

**Combat:** Revised, realistic, easy-to-learn system.

**Travel:** Types of travel, time scales, vehicles, encounters, maintenance, fuel, repairs.

**Encounters:** Dangerous environments, radiation, disease, contaminants, reasons for encounters, typical adventures.

**Equipment:** Weapons, supplies, vehicles, munitions, costs, availability.

**Danger:** Places to go and reasons to go there. Plus reasons to wish you hadn't.

**Twilight: 2000:** Roleplaying in the devastation of WWII.

**2nd Edition Twilight: 2000.**

The boxed set includes a 288-page basic rule book, 20x28" map of Europe, and blank forms.

GDW: 2001.  
Boxed.  
\$24.00.



At your hobby  
or game store  
July 28, 1990.

“WHAT FOOLS WE WERE to allow ourselves to be lulled into a warm sense of security by the events of the late '80s and early '90s. How childlike we were in our trumpeting of the new age of peace, prosperity, and good will. Democracy had come to Europe, and that meant that peace had come to Europe, for democracies never made war on other democracies.

“What utter rot!

“How could we have believed such naive rubbish with the lessons of history so plainly before us? Democracies have *always* made war on other democracies; it has been a fact of life since the earliest democracies flourished in Greece, and warred continuously upon each other.

“How could we have forgotten that in the War of 1812 the two great western democracies made enthusiastic, aggressive war on each other?

“How could we have forgotten that democracies represent the will of the people, and that the will of the people is often for war?

“How could we have forgotten that Hitler was elected?”

*Janosz Skrivkin  
Chancellor of Croatia  
1999*

# 20th Century Air-To-Air Combat

## USING THE BATTLETECH / AEROTECH SYSTEM

The *Battle-Tech/AeroTech* rules covering air combat is fast moving and clean. The game covers combat in the 31st century. With a little help, the rules work nicely in simulating air combat in the late 20th century. For those players not interested in modern day combat, the aircraft stats can be used for conventional aircraft in your *BattleTech* games. Think of it in these terms:

why design new aircraft when you can choose combat-tested, proven designs? I have incorporated what I feel are corrections to some of the rules covering fuel and air-to-air missiles.

### Realistic Fuel Weight Compared To Range:

Comparing the range that modern fighters have with the amount of fuel that they carry indicates that the *BattleTech* formula for finding fuel points is not realistic. Both amounts are given below.

1 to 10 Ton Aircraft=1 ton of fuel=2,000 Points or 650 miles.

11 to 30 Ton Aircraft=1 ton of fuel=1,000 Points or 650 miles.

### Scale And Weight Data:

Ten second turn/One hex=1,640 ft.

Typical jet fuel weight: 6.55 pounds per gallon.

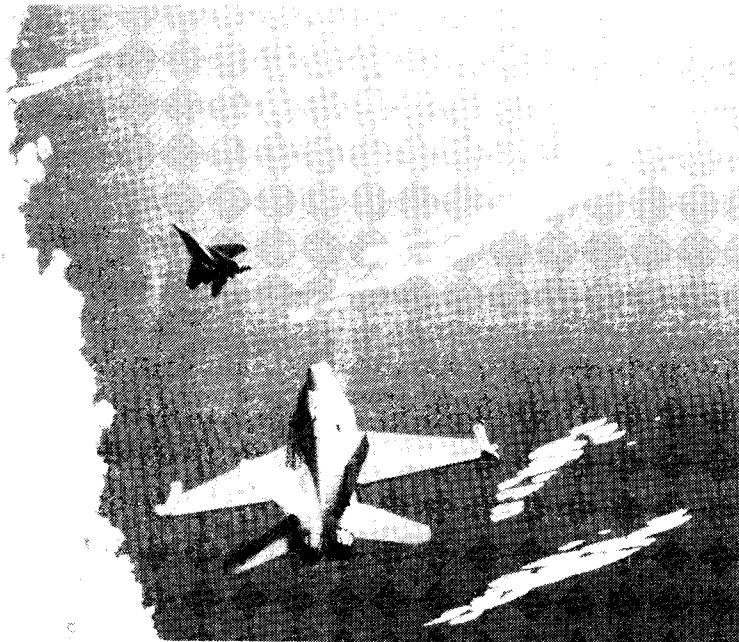

*Gary A. Kalin*

### Optional Air-To-Air Missiles

Use the AA missiles optional rules when simulating aerial combat of the late 20th century. Combat with AA missiles is conducted like standard missile attacks per the *AeroTech* rules, but with only a few changes. AA missiles compare to typical short or long range missile launchers. Find the *AeroTech* missile launcher data that matches

the AA missile. Conduct combat as normal. Roll for missile hits per the *AeroTech* rules. The AA missiles are not composed of many smaller missiles. The missile hit table represents the distance the target was away when the missile exploded. AA missiles do not have a bomb rating due to their small size. Any and all weapons or fuel tanks mounted on pylons will be damaged and rendered useless when the location of their suspension receives damage.

### Flares And Chaff

Flares and chaff are the counter measures to modern air-to-air missiles. Long lasting flares confuse the infrared seeker assemblies and strips of chaff (metal) foil released in cloud confuse tracking radar. The number of each type of counter measures that is in a dispenser is predetermined before the game. Any number and type that are carried may be fired each game turn. Each flare or chaff fired in a turn will

US MISSILE	AEROTECH EQUIVALENT	USSR MISSILE	AEROTECH EQUIVALENT
AIM-9	One SRM 6-pack	AA-3	One SRM 6-pack
AIM-7	One LRM 15-pack	AA-6	One LRM 15-pack
AIM-54	One LRM 20-pack	AA-8	One SRM 6-pack
AIM-120	One SRM 6-pack		
30 Gallon Fuel Drop Tank: LOAD RATING=20			

be a negative modifier to the missile hits dice roll. Example: An AIM-9 strikes a target aircraft. The attack is equal to being hit by six short range missiles. The target fires four flares. That would be a negative four for the missile hits dice roll. The roll is a nine, reduced to five, resulting in only three missile hits instead of five.

### Optional Air-To-Air (AA) Missile Movement

AA missiles move like aircraft. Their time in flight is limited because of the small fuel supply they carry. They must move at their top speed each turn, never less. AA missiles must track or be guided to strike their target. All missiles can change facing by one hexside per new hex entered. Each facing change costs one hex of speed. Example: A missile with a speed of 13 hexs per turn makes one facing change for each of four hexs it moves, for a total of eight speed points used. It still has five points to use.

### IR Missiles

IR missiles must lock on to the heat emissions that radiate from aircraft in order to track them before they are launched. The IR missile tracking unit has a limited field of view. The target of an IR missile must be in the tracking zone of the launching aircraft/missile. After it is launched, the IR missile will "home in" on the target aircraft as long as it is within the IR tracking field of view, which is the front 60 degrees of the aircraft/missile.

### Radar Missiles

Radar missiles must lock on to a radar beam reflecting off an aircraft in order to track them before they are launched. The tracking unit has a limited field of view. The target of a radar missile must be in the tracking zone of the launching aircraft/missile. After it is launched, some missiles will "home in" on the target aircraft as long as it is within the missile's radar tracking field of view. Some must be guided from the



launching aircraft. The launching aircraft must keep the target in its tracking field of view for missiles that need to be guided. If the target aircraft ends the game turn outside the radar tracking field of view before the missile hits, the lockon is broken and the missile is removed from the map. The radar field of view is the front 60 degrees of the aircraft/missile.

## AIR-TO-AIR MISSILE AEROTECH RANGE TABLE

### US BUILT MISSILES

MISSILE	RANGE	SPEED	TRACKING
AIM-9L (IR)	36 Hexs	12 Hexs (3 turns in flight)	Homing
AIM-7L (Radar)	160 Hexs	20 Hexs (8 turns in flight)	Needs guiding
AIM-7M (Radar)	240 Hexs	20 Hexs (12 turns in flight)	Needs guiding
AIM-54A (Radar)	800 Hexs	30 Hexs (26 turns in flight)	Homing
AIM-120A (Radar)	100 Hexs	25 Hexs (4 turns in flight)	Homing

### USSR BUILT MISSILES

MISSILE	RANGE	SPEED	TRACKING
AA-3 (IR)	40 Hexs	20 Hexs (2 turns in flight)	Homing
AA-3 (Radar)	40 Hexs	20 Hexs (2 turns in flight)	Needs guiding
AA-6 (IR)	26 Hexs	13 Hexs (2 turns in flight)	Homing
AA-6 (Radar)	52 Hexs	13 Hexs (4 turns in flight)	Needs guiding
AA-8 (IR)	26 Hexs	13 Hexs (2 turns in flight)	Homing

**Clarification To Thrust Loss And Bomb Loads**

The rule covering thrust loss from externally mounted bomb loads in the *AeroTech* rules is technically inaccurate. In the real world, the amount of aircraft thrust never changes. Its maximum speed and the amount of fuel used will change when carrying a large bomb load (external stores).

1. Speed restrictions: Aircraft with any externally mounted stores (bombs, fuel, or missiles) may not use over thrust.

2. Aircraft can carry external stores up to their gross weight limit. All weapons and fuel drop tanks must be added to the aircraft's empty weight. The heavier an aircraft is the more fuel it uses. An aircraft gross weight is double its empty weight. (This is an abstract way to find gross weight, but it tends to be fairly accurate when compared to actual aircraft empty and gross weights.) Use the Thrust Loss Table found in the *AeroTech* rules to calculate fuel usage. The Bomb Rating Column of the Thrust Loss Table is equal to the weight of the weapons or fuel carried. The Thrust Points Loss Column is equal to extra fuel points used each turn. Round all fractions up to the nearest whole fuel point. Example: An aircraft is carrying an external stores load with a rating of 80. That aircraft will use an extra 2 points (1.6 rounded up) of fuel each turn as long as it carries them.

Air-to-air missiles are designed to be carried without producing drag on the aircraft. All combat aircraft may carry up to their maximum limit of AA missiles as stated in their typical air-to-air combat loads without any speed restrictions or fuel loss.

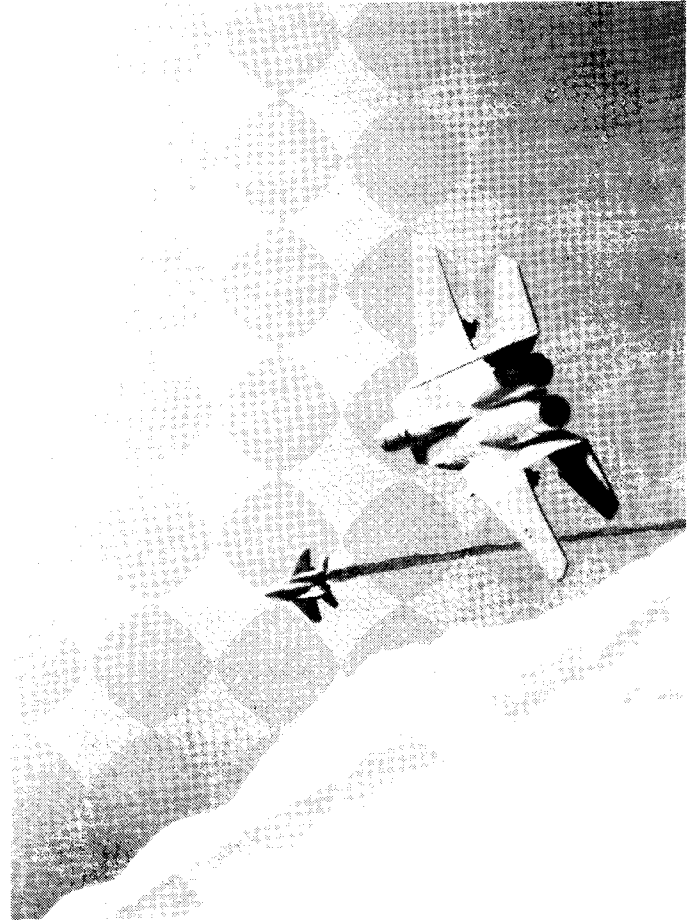

**AV-8B Harrier II**

Engine: 2 Tons  
 VSTOL: 0.7 Tons  
 Controls: 0.7 Tons  
 Armor: 1.5 Tons (24 Points)

Basic weight: 7 Tons	Gross weight: 15 Tons
Thrust: 5	Over Thrust: 7
Structural Integrity: 5	Crew: One Pilot
Fuel: 2.1 Tons (63 BattleTech points)	4,200 revised fuel points
Armor location:	Nose: 4    Right Wing: 2    Cockpit: 4
	Left Wing: 2    Fuselage: 8    Engine: 4

**NOTES:**

1. No weapons mounted internally.
2. Seven pylons for externally mounted fuel and weapons (only six when GAU-12/U is mounted).
3. One GAU-12/U 25mm cannon externally mounted, facing forward only (ammo for ten shots).
4. TV/Laser target seeker and tracker (no radar).
5. Forty shot chaff/flare dispenser.
6. Typical air-to-air combat weapons load:
  - A. Four AIM-9 Sidewinders + Two 300 gallon fuel tanks (4,000 fuel points).
  - B. Four AIM-9 Sidewinders + One GAU-12/U 25mm cannon.

**F-4 Phantom II**

Engine: 9 Tons (130)  
 Controls: 1.6 Tons  
 Fuel: 2.9 Tons (87 BattleTech points)  
 Weapons: One M61 20mm cannon facing forward only with ammo for twelve shots: 1 Ton.  
 Armor 1.5 Tons (24 Points)

Basic weight: 16 Tons	Gross weight: 31 Tons
Thrust: 8	Over Thrust: 12
Structural Integrity: 8	Crew: One pilot, one weapons officer
Armor location:	Nose:2    Right Wing: 2    Cockpit: 6
	Left Wing: 2    Fuselage: 8    Engine: 4

## NOTES:

1. May carry the AIM-120 air-to-air missile in place of the AIM-7.
2. Five pylons for externally mounted fuel and weapons.
3. Four recesses for AIM-7 or AIM-120 AA missiles.
4. TV/Laser target seeker and tracker and radar.
5. Forty shot chaff/flare dispenser.
6. Typical air-to-air combat weapons load:
  - A. Four AIM-9 Sidewinder + Four AIM-7 Sparrow + Two 300 gallon fuel tanks (4,000 fuel points).
  - B. Two AIM-9 Sidewinder + Six AIM-7 Sparrow + Two 300 gallon fuel tanks (4,000 fuel points).

**F-14 Tomcat**

Basic weight: 20 Tons	Gross weight: 37 Tons	
Engine: 14 Tons (180)	Thrust: 9	Over Thrust: 13
Controls: 2 Tons	Crew: One pilot, one weapons officer	
Structural Integrity: 9	Fuel: 2 Tons (60 BattleTech points) 2,000 revised fuel points	
Weapons: One M61 20mm cannon facing forward only with ammo for twelve shots: 1 Ton		
Armor: One Ton (16 points)	Armor location:	Nose: 1    Right Wing: 2    Cockpit: 4
		Left Wing: 2    Fuselage: 5    Engine: 2

## NOTES:

1. May carry the AIM-120 air-to-air missile in place of the AIM-7.
2. Four pylons for externally mounted fuel and weapons.
3. Four recesses for AIM-54, AIM-9, or AIM-120 AA missiles (no drag).
4. TV/Laser target seeker and tracker and radar.
5. Forty shot chaff/flare dispenser.
6. Only aircraft to use the AIM-54 Phoenix air-to-air missile.
7. Typical air-to-air combat weapons load:
  - A. Four AIM-54 Phoenix + Two AIM-7 Sparrow + Two AIM-9 Sidewinder + Two 300 gal. fuel tanks (4,000 fuel pts.)
  - B. Two AIM-9 Sidewinder + Six AIM-54 Phoenix + Two 300 gallon fuel tanks (4,000 fuel points).

**F/A-18 Hornet**

Basic weight: 11.5 Tons	Gross weight: 24 Tons	
Engine: 6 Tons (95)	Thrust: 8	Over Thrust: 12
Controls: 1.1 Tons	Structural Integrity: 8	
Crew: One pilot		
Fuel: 1.9 Tons (57 BattleTech points) 1,900 revised fuel points		
Weapons: One M61 20mm cannon facing forward only with ammo for twelve shots: 1 Ton.		
Armor: 1.5 Tons (24 Points)	Armor location:	Nose: 2    Right Wing: 2    Cockpit: 4
		Left Wing: 2    Fuselage: 8    Engine: 6

## NOTES:

1. May carry the AIM-120 air-to-air missile in place of the AIM-7.
2. Five pylons for externally mounted fuel and weapons.
3. Two AIM-9s carried on the wing tips.
4. TV/Laser target seeker and tracker and radar.
5. Forty shot chaff/flare dispenser.
6. Typical air-to-air combat weapons load:
  - A. Six AIM-9 Sidewinder + Two AIM-7 Sparrow + Three 300 gallon fuel tanks (6,000 fuel points).
  - B. Two AIM-9 Sidewinder + Six AIM-7 Sparrow + Three 300 gallon fuel tanks (6,000 fuel points).

**MIG-21 Fishbed**

Basic weight: 6.5 Tons	Gross weight: 10.5 Tons	
Engine: 3 Tons (55)	Thrust: 8	Over Thrust: 12
Controls: 0.7 Tons	Structural Integrity: 8	
Crew: One pilot		
Fuel: 1.3 Tons (39 BattleTech points) 2,600 revised fuel points		
Weapons: One NR-30 30mm cannon facing forward only with ammo for 4 shots: 1 Ton.		
Armor: 0.5 Tons (8 Points)	Armor location:	Nose: 1    Right Wing: 1    Cockpit: 2
		Left Wing: 1    Fuselage: 2    Engine: 1

## NOTES:

1. Five pylons for externally mounted fuel and weapons.
2. Radar tracking only.
3. No chaff/flare dispenser.
4. Typical air-to-air combat weapons load:
  - A. Two AA-3 (Radar) + Two AA-8 (IR) + One 300 gallon fuel tank (2,000 fuel points).
  - B. Two AA-8 (IR) + Two 300 gallon fuel tanks (4,000 fuel points).

<b>MIG-25 Foxbat</b>	Basic weight: 11 Tons	Gross weight: 20 Tons
Engine: 8 Tons (125)	Thrust: 11	Over Thrust: 16
Controls: 1.1 Tons	Structural Integrity: 11	Crew: One pilot
Fuel: 1.4 Tons (42 BattleTech points) 1,400 revised fuel points		
Weapons: No internally mounted weapons		
Armor: 0.5 Tons (8 Points)	Armor location:	Nose: 1      Right Wing: 1      Cockpit: 2
		Left Wing: 1      Fuselage: 2      Engine: 1

## NOTES:

1. Four pylons for externally mounted fuel and weapons.
2. Radar tracking only.
3. Twenty shot chaff/flare dispenser.
4. Typical air-to-air combat weapons load:
  - A. Two AA-3 (Radar) + Two AA-8 (IR) + One 300 gallon fuel tank (2,000 fuel points).
  - B. Two AA-8 (IR) + Two 300 gallon fuel tanks (4,000 fuel points).

<b>MIG-29</b>	Basic weight: 9 Tons	Gross weight: 20 Tons
Engine: 5 Tons (85)	Thrust: 9	Over Thrust: 13
Controls: 0.9 Tons	Structural Integrity: 9	Crew: One pilot
Fuel: 1.6 Tons (48 BattleTech points) 3,200 revised fuel points		
Weapons: One NR-30 30mm cannon facing forward only with ammo for 4 shots: 1 Ton		
Armor: 1.5 Tons (24 Points)	Armor location:	Nose: 2      Right Wing: 2      Cockpit: 4
		Left Wing: 2      Fuselage: 8      Engine: 6

## NOTES:

1. Four pylons for externally mounted fuel and weapons.
2. Radar tracking and TV/Laser target seeker and tracker.
3. Forty shot chaff/flare dispenser.
4. Typical air-to-air combat weapons load:
  - A. Two AA-3 (Radar) + Two AA-8 (IR).
  - B. Two AA-8 (IR) + Two 300 gallon fuel tanks (4,000 fuel points).

<b>SU-19 Fencer</b>	Basic weight: 18 Tons	Gross weight: 34 Tons
Engine: 12 Tons (165)	Thrust: 8	Over Thrust: 12
Controls: 1.8 Tons	Structural Integrity: 8	Crew: One pilot
Fuel: 1.7 Tons (51 BattleTech points) 1,700 revised fuel points		
Weapons: One GSh-23 23mm cannon facing forward only with ammo for 10 shots: 1 Ton		
Armor: 1.5 Tons (24 Points)	Armor location:	Nose: 2      Right Wing: 2      Cockpit: 4
		Left Wing: 2      Fuselage: 8      Engine: 6

## NOTES:

1. Four pylons for externally mounted fuel and weapons.
2. Radar tracking and TV/Laser target seeker and tracker.
3. Forty shot chaff/flare dispenser.
4. Typical air-to-air combat weapons load:
  - A. Two AA-3 (Radar) + Two AA-8 (IR) + One 300 gallon fuel tank (2,000 fuel points).
  - B. Two AA-8 (IR) + Two 300 gallon fuel tanks (4,000 fuel points). ■

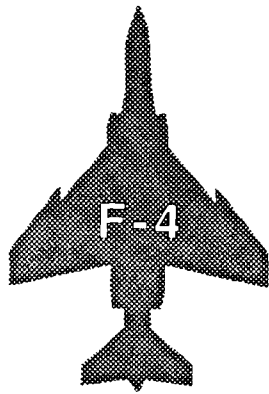

F-4

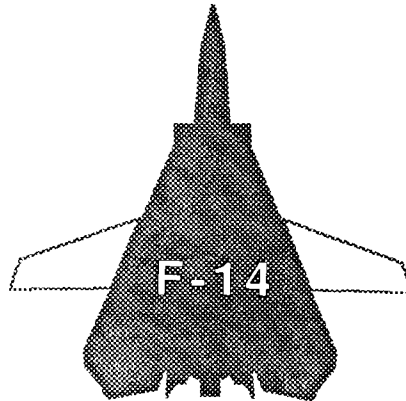

F-14

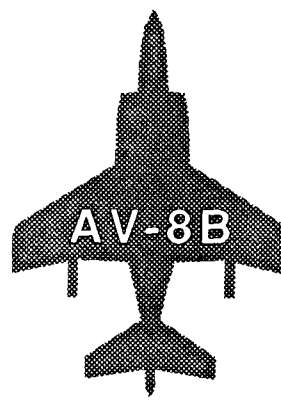

AV-8B

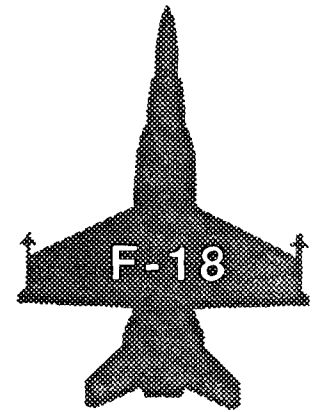

F-18

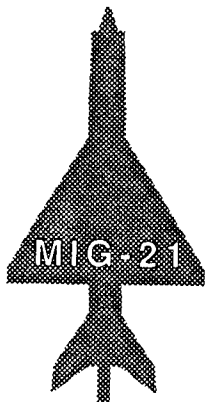

MIG-21

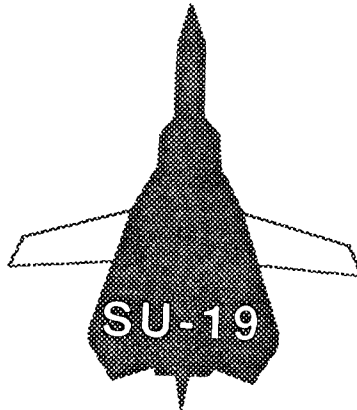

SU-19

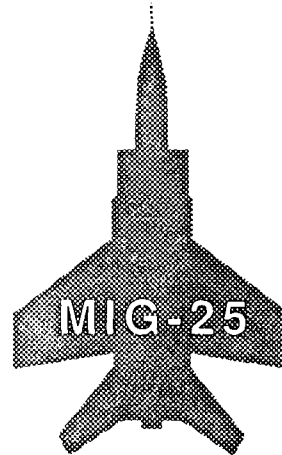

MIG-25



MIG-29

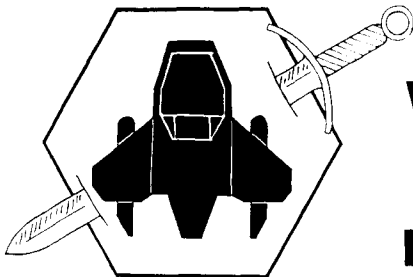

## SWORD & STARSHIP ENTERPRISES WE ALWAYS HAVE 25% OFF ALL GAMES

If we don't list a game you are looking for in our ad or our catalog, please let us know — we do special orders, too! Let us know what you're looking for.

### Chaosium

Call of Cthulu RPG . . . . .	\$16.50
Pendragon RPG . . . . .	\$16.50
Knights Adventurous . . . . .	\$14.25
The Boy King . . . . .	\$14.25
<b>FASA</b>	
Shadowrun RPG . . . . .	\$15.00
Shadowrun GM Screen . . . . .	\$7.50
Harlequin . . . . .	\$9.00
Neo-Anarchist Guide . . . . .	\$11.25
Seattle Sourcebook . . . . .	\$11.25
The Grimoire . . . . .	\$9.00
Mechwarrior RPG . . . . .	\$11.25
BattleTech . . . . .	\$15.00
BT Compendium . . . . .	\$11.25
Mech Record Sheets #1 . . . . .	\$6.00
<b>GDW</b>	
Twilight:2000 (2nd ed. Bxd) . . . . .	\$22.50
Infantry Weapons/World . . . . .	\$9.00

MERC: 2000 . . . . .	\$12.00
Bangkok Sourcebook . . . . .	\$9.00
Cadillacs & Dinosaurs . . . . .	\$13.50
<b>Iron Crown Enterprises</b>	
MERP RPG (boxed set) . . . . .	\$13.50
MERP Guidebook II . . . . .	\$11.25
Creatures of Middle Earth . . . . .	\$7.50
Treasures of Middle Earth . . . . .	\$11.25
Cyberspace RPG . . . . .	\$13.75
Cyberskeller . . . . .	\$7.50
RoleMaster RPG . . . . .	\$28.50
RM Character Records . . . . .	\$9.00
RM Heroes & Rogues . . . . .	\$12.00
SpaceMaster RPG . . . . .	\$22.50
SpaceMaster Companion . . . . .	\$9.75
Star Strike . . . . .	\$22.50
Armored Assault . . . . .	\$26.50
Dark Space . . . . .	\$12.00
<b>Lion Rampant/White Wolf</b>	

Ars Magica RPG . . . . .	\$13.50
Paths Of Intrigue Cards . . . . .	\$3.75
<b>Palladium Books</b>	
Rifts RPG . . . . .	\$18.75
Rifts Sourcebook . . . . .	\$9.00
<b>TSR</b>	
ADD2 Player's Hndbk . . . . .	\$15.00
ADD2 DM Guide . . . . .	\$13.50
Monstr. Comp. #9 . . . . .	\$8.25
<b>West End Games</b>	
Torg, Possibility Wars . . . . .	\$22.50
Cyberpapacy Srcbk . . . . .	\$13.50
Aysle Sourcebook . . . . .	\$13.50
High Lord of Earth . . . . .	\$9.00
Pixaud's Grimoire . . . . .	\$11.25
Star Wars RPG . . . . .	\$13.50
Star Wars Sourcebook . . . . .	\$13.50
Miniatures Battles . . . . .	\$13.50
Rebel Alliance Srcbk . . . . .	\$15.00

### R. Talsorian Games

Cyberpunk 2020 RPG . . . . .	\$15.00
Solo of Fortune . . . . .	\$7.50
Hardwired . . . . .	\$9.00
Chromebook . . . . .	\$9.00

### Games Workshop

Talisman . . . . .	\$26.75
Talisman Expansion Set . . . . .	\$12.75
Talisman Adventure . . . . .	\$12.75
Talisman Dungeon . . . . .	\$17.25
Talisman Timescape . . . . .	\$17.25
Talisman City . . . . .	\$17.25
Dungeonquest . . . . .	\$26.25
Adv. Space Crusade . . . . .	\$42.00
Dark Future . . . . .	\$30.00

### StarChild Publications

Monsters! . . . . .	\$11.25
Justifiers RPG . . . . .	\$7.50
Domination RPG . . . . .	\$7.50

SWORD & STARSHIP ENTERPRISES, P. O. BOX 3373, TRI-CITIES WA 99302-3373

For a free catalog, send a S.A.S.E. \* \* \* If ordering from this ad, include \$2.50 shipping and handling. No COD orders and no delivery outside continental USA (for special arrangements, see catalog). We accept personal checks (not shipped until check clears) and money orders. Do not send cash. Orders shipped UPS. WA residents add 7.8% sales tax.

# HEROES OF YESTERDAY

"Heroes Of Yesterday And Tomorrow" is a collection of full-page character studies of both fantasy and science fiction characters, useful as both player and nonplayer characters in roleplaying. This is the kind of book you can browse through and say, "Oh! Now that's me — that's my character!" Even art fans will be pleased to own this book. The quality of the art will knock your socks off!

\$7.95 ISBN 0-9627030-2-8 Stock #1003

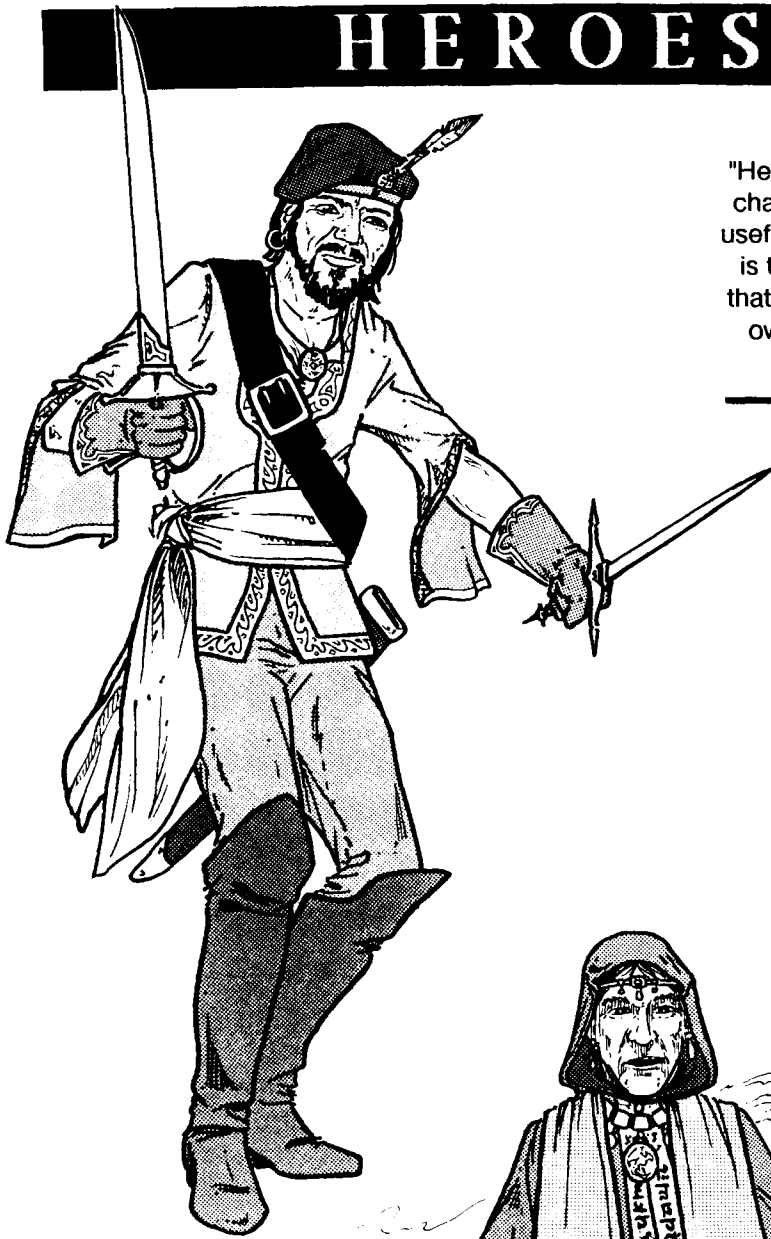



# DAY AND TOMORROW

Including the works of these fine artists:

Rob Caswell, Liz Danforth, David Deitrick, Dan Engwall, Rick Harris, James B. King, Alfred Klosterman, Phil Morrissey, Blair Reynolds, Richard Tomasic, and David Transue.

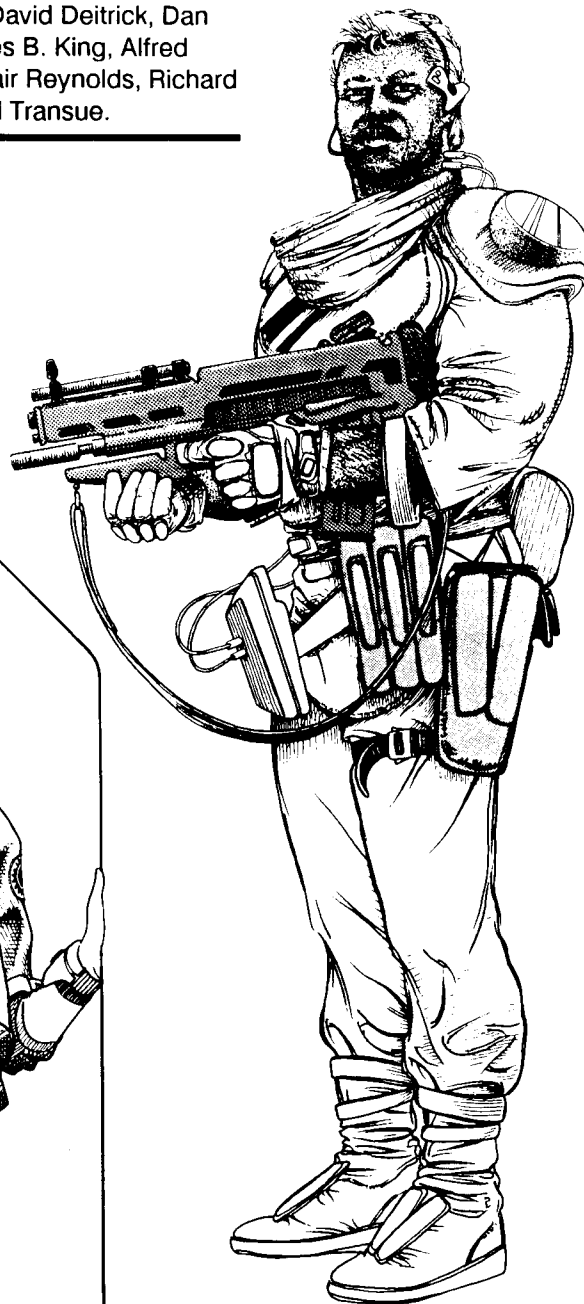
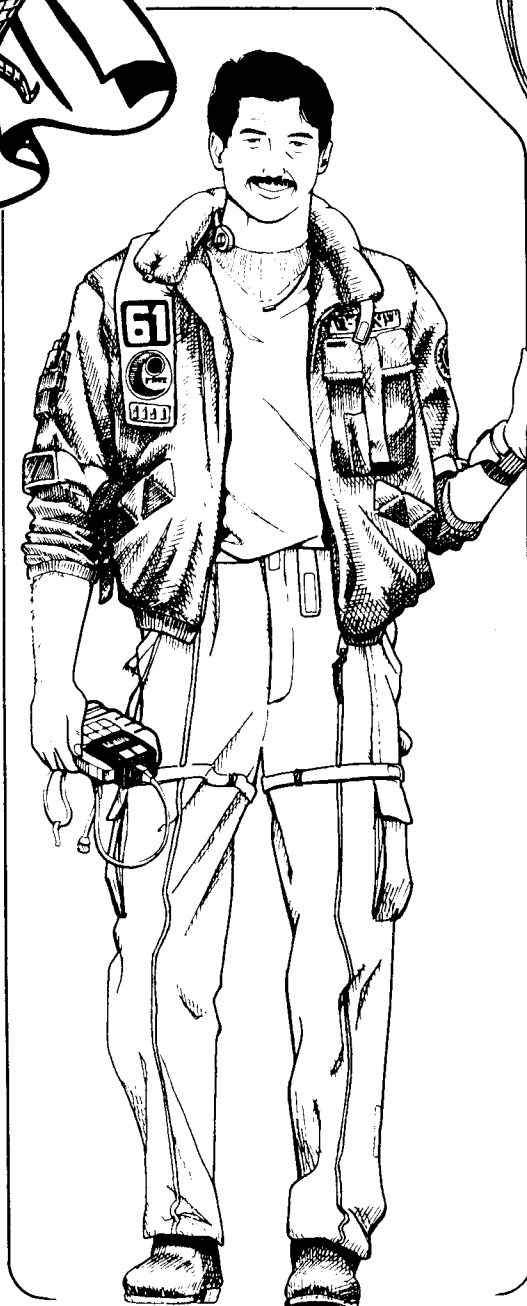
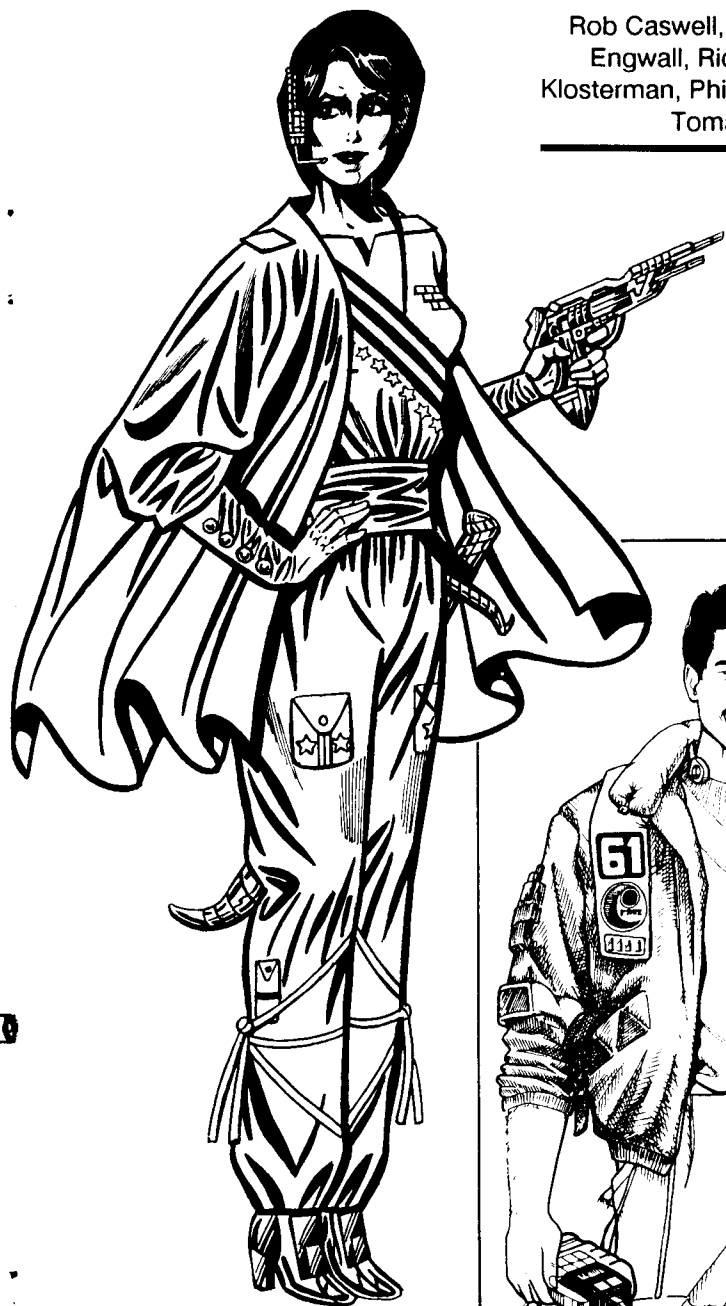

**"Heroes Of Yesterday  
And Tomorrow" is a July  
release from StarLance  
Publications. Ask your  
dealer to stock this fine  
book!**

Writing for a quarterly periodical can be something of an adventure at times, particularly when trying to guess the publication date of what you've written. If I've guessed right, this should be in print sometime in late March or early April — right in time for April Fool's Day. With the spirit of the holiday in mind, let's kick off the reviews with a bit of humor.

### Phule's Company

Robert Asprin. 232 pp. 1990 Ace SF

Start with a military arm that, like the Army in Heinlein's *Starship Troopers*, must take *anyone* who applies, and can't boot them out. Set it up like the Foreign Legion where an enlistee's past is "forgotten." Now give this service arm less funding than the Confederate Army. Looks bad? That's only the beginning. Take the dregs of the enlistees and officers, the psychos, losers, pacifists and klutzes, and dump them into a unit "unofficially" referred to as "Omega Company." Hold on, it gets worse! Place in charge of this motley crew a millionaire, hot-shot playboy with delusions of grandeur and no regard for tradition (the guy goes to the field with his own butler!). Now you have Phule's (pronounced "Fool's") Company, the first in what is promised to be a series of SF humor, in the tradition of *The Stainless Steel Rat*.

For those of you who've spun out reams of paper, discarding legions of, shall we say...less than perfect characters and wished there was something to do with them other than NPC cannon fodder — this book's for you! Well written, light, but *not* straining for a punchline, this diversion of Bob Asprin's out of Fantasy and into SF is a whole lot of fun. Phule's Company are no fools, and you won't feel like one either for getting your hands on this!

### Voyage Of The Star Wolf

David Gerrold. 276 pp. 1990 Bantam Spectra

David Gerrold is the author of the *War Against The Chtorr* series. In this book, he creates yet another incredibly strong, smart alien race to pit Humankind up against. This time, however, the aliens (known as the Morthan), used to be us! The Morthan are the product of nearly 1500 years of genetic and biomechanical manipulation techniques. They have developed a culture that makes the Klingons look like Sunday School teachers, and a superiority attitude that would make the most fanatical of Hitler's Nazis look dithering and indecisive by comparison.

While decidedly readable, it suffers from an occasionally confusing story line and "gimmicks" that seemingly pop up out of nowhere. The aliens' insights on shipboard life and intra-service politics more than make up for these minor flaws.

### The World Next Door

Brad Ferguson. 342 pp. 1990 TOR SF

Admittedly, my favorite SF background is the "Post Holocaust/Catastrophe" scenario. I think that's why I enjoyed GDW's *Twilight: 2000*, and why my own novel was set in a similar background. Alternate universes are probably my next favorite plot gimmick, so Ferguson really hooked me with this one! The background is: what if the Cuban missile crisis of 1962 had ended differently? That is, what if, instead of backing off, Krushchev and Castro had launched a first-strike? What if that really *had* happened, but in a universe parallel to our own, and *we* are about to blow ourselves up in present time? Here's the zinger:



## Words To Game By

### Fiction Reviews by Jerry Campbell

as the time of our own self-immolation draws closer, what if a "door" opens between the worlds, the link being your "opposite" in the other reality?

Excellent insights on life after a low-level nuke exchange, and damn good writing throughout make this one a keeper in my library. If you took my earlier advice and got a copy of *There Will Be War, Vol. 8*, you'll recognize the background, as well as some of the story itself.

### The Stars Must Wait

Keith Laumer. 283 pp. 1990 Baen Books

Some years back, Laumer came out with a collection of short stories called *Bolo*, which soon became a classic in the field. A later edition added the story "Rouge Bolo" (once a book in it's own right), and was retitled *The Complete Bolo*. In those collections was a particularly poignant tale called "The Night of the Trolls"; sort of a modern-day Rip Van Winkle story about a man who had been in suspended animation aboard the first true interplanetary ship for some 80 years, who awakens to find the world he knew devastated and fallen into semi-feudal savagery. In the original story, he overcame great odds and eventually launched the ship. I'm not telling you how this extensive rewrite of "Trolls" ends. I will say, however, that I liked this version much better, both for the ending and for the additional material. I also enjoyed catching Baen Books with an exceptionally rare (for them) glaring typo! See if you can find it. Yet another "keeper" in my library.

### Falkenberg's Legion

Jerry Pournelle. 432 pp. 1990 Baen Books

Several years back, Pournelle wrote a couple of really good combat SF tales called *West Of Honor* and *The Mercenary*. These are set in a "future history" where the U.S. and U.S.S.R. have allied in a tenuous pact to enforce peace upon the world, called The CoDominium. Mankind somehow manages to reach the stars, in spite of the CoDominium's suppression of any technology that might have military applications, and is soon about the normal human endeavor of trying to subjugate new worlds and each other. The central character of both stories is a man named John Christian Falkenberg, who's sort of a soldier's soldier; a tactical genius with a unique grasp of the forces that create history and society.

Those two books are combined here into one concise story. If you haven't read the aforementioned tales, then by all means, get a copy of *Legion!* The stories are benchmark works on small unit engagements (using SF military technology), High/Low-tech interplay, and politics in general. They're just darned good yarns, too!

If you have read them before, get this book anyway. The first sections are *entirely new* material that answers a lot of questions about "Johnny Christian's" past.

### Total War (The Fleet, Book 5)

Edited by David Drake and Bill Fawcett. Various writers. 278 pp. 1990 Ace SF

David Drake is, in my opinion, one of two of the best combat SF writers, ever. Like Larry Niven and Bob Asprin, he's created a "universe" to write in and invited other writers to create stories, within the context of that universe. The Fleet is the hard-pressed military arm of humanity in a distant future. In this, the fifth book of the series, humanity has finally defeated a weasel-like race known as the Khalia, who'd almost totally destroyed the Fleet. Now it appears that the Khalia weren't the enemy after all, merely a low-tech society who'd been given high-tech "toys" and pointed in Earth's general direction. (Sound like any Third World countries you know?) Behind the scenes, pulling the Khalia's strings is a *human* Trader-Warrior society called the Syndicate; and they mean to either absorb or eliminate the threat they perceive Earth to be.

While many of the stories in *Total War* are quite good, many leave you wondering just what happened. Rough story lines, incomplete descriptions and abrupt, apparently pointless endings, leave you with less than a feeling of satisfaction for the book as a whole. Still, there are some really good gaming ideas (even you "007" players will find material here!), and the Khalia are a very interesting race.

## GOLDEN OLDIES

### Tool Of The Trade

Joe Haldeman. 248 pp. 1987 Avon Books

A *very* believable and somewhat chilling tale of mind-control. What if you could create an unobtrusive device, shaped, say, like a watch, that would give you total and complete persuasive ability over others? People would be literally compelled to do anything you told them to do... *anything*. That's the idea behind this little thriller, and the twists the story takes are nothing short of amazing. Scour your used book store for this one.

### Polaris

Sheldon Perkins. 208 pp. 1979 Tower Pubns.

My, how prices have changed in twelve years! I'm on my second copy of this book, the first one having finally fallen apart from frequent re-reads and loanings. The *Polaris* is a starship, a cruiser with a *whole* lot of problems, the largest of which is an extremely bigoted Command Group. The prejudice here being Terra vs. anyone else. The story line is simple, no flashy plot gimmicks or "gee-whiz" techno toys; the attraction of this story is how Perkins chooses to utilize basic human flaws and "commonplace" SF weaponry and gear in some rather novel ways. I really liked the character development; the people in the story, even the "bad guys," are real people. Downside? Perkins seemed to have a real fixation for full names and titles when writing *Polaris*. ■



**Voyages SF 7 \$1.00**

**MegaTraveller:** Bird Of Prey-Part 1; The Shattered Imperium. **Star Wars:** The Anatra Dora; Carrier Assignment; Modified Space Combat. **SpaceMaster:** Linguistic Ties.

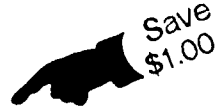

**Voyages SF 8 \$1.50**

Beyond The Looking Glass **Star Wars:** Rebel Justice; Star Maps. **MegaTraveller:** Kfangu Fighter; Cryogenic Surrender; Hull Damage; Ancient Science Of Shrinking. **Space 1889:** Americans In The Ether; Military Dress.



**Voyages SF 9 \$1.50**

Three-dimensional Distance Calculations. **2300 AD:** The Kafer Connection. **Mega-Traveller:** Bird Of Prey-Part 2; Petersburg. **Cyberpunk/Gurps Space:** Vampires In Space?! **Star Wars:** A World In Revolt.



**Voyages SF 10 \$1.50**

**Gurps Space:** Red Sun Black Death-Part 1. **MegaTraveller:** Images Of The Shattered Imperium; Zidhaedz Close Escort. **Space-Master:** Spacial Delivery. **Star Wars:** S400 Police Vest. **Review:** Albedo RPG.

**Voyages SF 11 \$2.50**

**Star Wars:** A Day At The Auction. **Star Trek:** Ships Of The Fleets. **SpaceMaster:** Silk Scorpion. **Gurps Space:** Red Sun Black Death-Part 2. **Reviews:** Worlds Beyond; High Colonies; Star Wars Galaxy Guide series.

**Voyages SF 12 \$2.75**

**MegaTraveller:** Stealth Aircraft; Finders, Inc. **Star Wars:** Hide And Go Seek; Long Term Star Wars; Guide To Blaster Weapons. **Star Trek:** S-16 Patrol Shuttle. **Reviews:** Morpheus; Cyberspace; Armored Assault.

**Voyages SF 13 \$2.75**

Mechanics Of Adventure Writing. Raid On The North Pole. Sanity In Space. **Space: 1889:** Rails In The Astusapes. **Star Wars:** Twinkle, Twinkle Little Star, How I Wonder Where You Are. **2300 AD:** Fort Bliss Class Destroyer. **MegaTraveller:** Exercise; Katlin C. Buchanan. **Reviews:** Torg; Buck Rogers XXVc.

**Voyages SF 14 \$2.75**

Unofficial Combat Errata For The Palladium RPG System. **Shadowrun:** The Go-Betweens. **Star Wars:** Gunsmiths; Effects Of Wounds. **Mega-Traveller:** Solomani Space Fighters; Corsair Contention. **GURPS Autoduel:** Case Of The Haunted Car. **2300 AD:** Encounter At Hesperus. **Reviews:** Rifts; Reich Star; Attack Of The Humans; GURPS Cyberpunk.

Word is getting around. **Voyages SF** is a great magazine! **Subscribe and get 4 quarterly issues for just \$10.**

**JUMPSPACE**

**Only 50 cents each!**

**Voyages SF** evolved from this low print run, amateur 'zine devoted to GDW's *Traveller*. We've discounted the \$2.50 cover price to clear our inventory!

#3: The Human Spirit (fiction); Hornet 23E Main Battle Tank; Modified Scout Courier; Smuggler's Wish List.

#4: A Moment With Naval Architect Tyler Purcell; Small Craft For System Defense; Sentry Class SDB; Mk XIV Liquid Explosive.

#5: SOLD OUT

#6: SOLD OUT

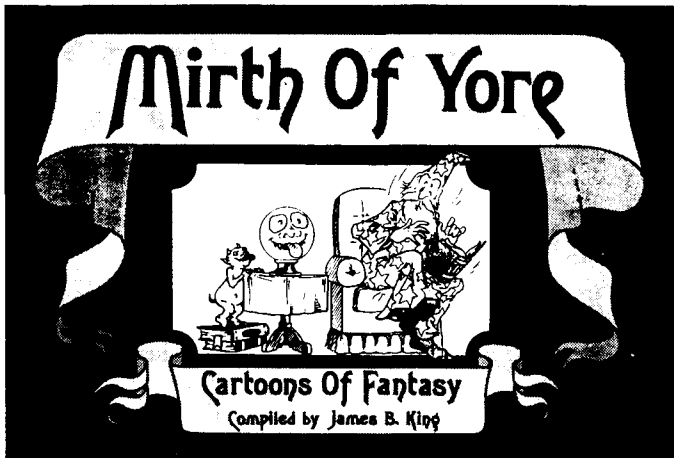

**Mirth Of Yore** is a prized collection of 92 fantasy cartoons, many never before published, by Darin Davis, Jerry Fuchs, Joseph Pillsbury, and Richard Tomasic, compiled by James B. King. If you're a fan of fantasy, you'll treasure this collection of great fantasy humor!

\$7.95. Stock No. 1001. ISBN 0-9627030-0-1.



**It's A Gamer's Life** is a collection of 60 gaming 'toons, including works from Jerry Fuchs, Joseph Pillsbury, and Richard Tomasic, compiled by James B. King. Adventuring in the varied realms of the hobby gets pretty serious. This is just what you need to tickle your funny bone!

\$5.50. Stock No. 1002. ISBN 0-9627030-1-X.



Ask your local dealer for these fine products or order direct from the publisher: **StarLance Publications, 50 Basin Drive, Mesa Washington 99343.** Include \$1.50 per order for P & H. Washington residents include 7.5% sales tax.

The game is as old as nations. It relies on a curious mix of the newest technologies and the oldest senses. Its methods rub against the grain of democracy, yet without it democracies cannot survive. "It" is the business of espionage, and it's alive and well in AutoDuel America.

The agencies that presently exist combine some of the old with the new. In the United States, the National Security Agency carries out most of the U.S.'s intelligence activities. (The CIA is now a small part of the NSA.) Canada has the Canadian Intelligence Service, Quebec has the SCE, Louisiana the Bureau for Secret Affairs, and Texas the Intelligence and Security Branch. (Oklahoma and Mexico are too fragmented to have cohesive intelligence agencies.)

These organizations have in common certain duties and goals. They are: advising the government on intelligence relating to national security; maintaining cooperation between departments; evaluation and communication of data; and carrying out operations and directives. The last part is what's gamable.

Those "Departments of Dirty Tricks" carry out the secret, dangerous, and daring missions that modern intelligence requires. Their work is often violent, and their agents can be the victims of both random and specific violence. But the jobs they do are vital, so they simply grin and endure.

Most have some restrictions on their activities. In democracies, these have to do more with obeying the Constitution. In dictatorships, restrictions come from political foes afraid of a secret service able to do anything to anyone. The most common rule prevents actions from taking place on home soil.

Personnel are usually recruited out of college or graduate school. Only field agents who are expected to engage in combat come from the military, and then only as commissioned officers with years of service behind them. All field agents go through special training. Terms vary from one to three years.

Texas is a special case in that many of the field agents come from the Texas Rangers. In addition to a great deal of training, they have practical knowledge of dealing with the public. However, Texas agents rank lowest when comparative studies of reports are made.

This leads us to the least glamorous and most important work operatives do: read and compile data. This varies from stealing secret documents to reading research papers on agriculture to watching the local viscast news. This can predict when the next war might come and why. It can mean the difference between success and failure of an operation. Without it governments are unable to make foreign policy decisions.

Gathering information has become easier than it was during the Cold War and before. The only way to gather data was to go where the data was and take pictures or compile a report. Technology has now made things easier, with satellites, drone aircraft, and computer nets. But there are risks. Many nets have secure or classified barriers to penetration. Drones and satellites can malfunction. A probe over enemy airspace could be shot down.

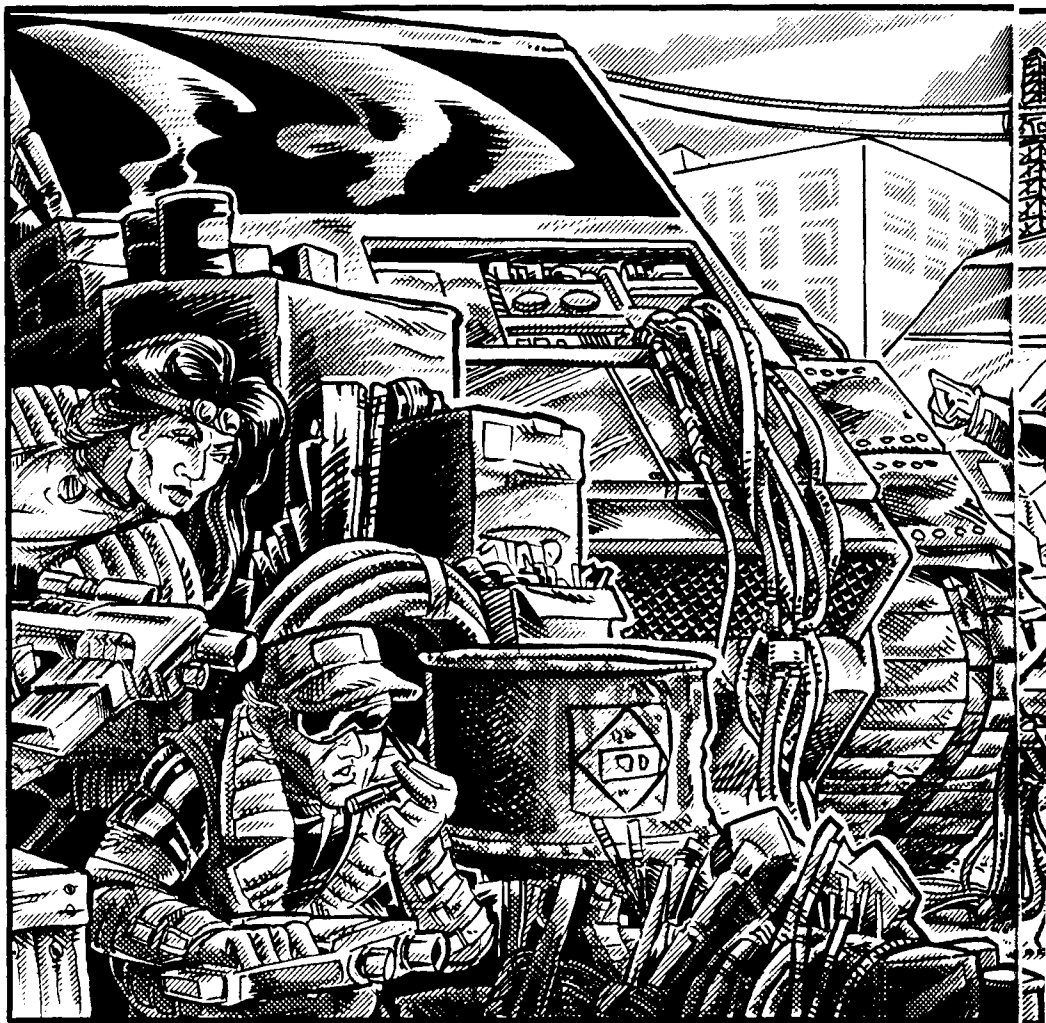

## Espionage Is Alive And Well In AutoDuel America

*Robert L. Collins*

That's where field agents come in. They do things like recover crashed drones, do personal surveillance, and cultivate double agents. These agents are based in field stations located in major cities in foreign countries.

Stations agents spend much of their careers "on station." They have extensive knowledge of local customs. Their cover is as members of embassy staff or as employees of a company's branch office. Though better protected than field agents, they are in constant danger of being discovered.

The covert action agents are the men and women who go behind the lines to do the special jobs that can't be done by station people. They get defectors out, take hard data surveys, kidnap

enemy officials, protect friendly agents; all the things that are the stuff of spy stories. These agents often work alone. Most of their time is spent with reports. They are told to avoid violence, but they are the ultimate force, the best of the best. If they can't do it, it can't be done.

The new technologies are a real help to field agents. Clones can assure that they don't have to risk their lives. Micros can simulate the mission while it's still being planned. The same super-small cameras used for surgery are also perfect for conducting surveillance. But this same technology also creates problems. Documents and IDs are much harder to forge. Metal and plastic detectors are at every airport. Instead of men, remote cameras watch borders. Information on a cube can be disguised as a pre-

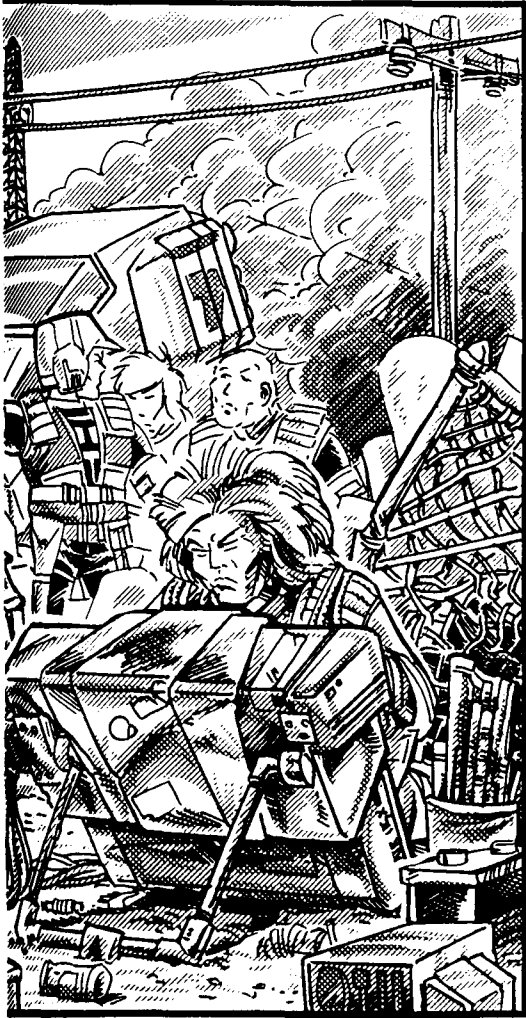

programmed cube.

A GM must use common sense when dealing with high-tech, but intelligence services will already have the next advance in their hands. If holo projectors exist spies are using them to sneak over borders. The same for pen lasers, string tape, and eye cameras.

As you may realize, using micros may lead to players "gaming out the game." To avoid this, limit micro use or apply a lot of the "unexpected element" to the real thing.

Here's how a special operation proceeds. The first step is a decision by the agency's operations director to determine if the need for one exists. Once that's done a proposal is made to the agency director. He may decide against it. If so, the plan is dropped. But if he decides in favor of the operation, he will approach any officials whose approval or support is needed. A formal presentation to the President is made with all parties having a say. If the President approves and the cabinet concurs, the mission gets clearance. Final plans are made, and personnel are assigned, briefed, and equipped.

Assuming the need is obvious and no turf battles occur, the process takes a morning or afternoon. The agent or agents are sent out by dinner. However, Murphy's Law can and does appear at these times. Sometimes, getting approval is an adventure itself!

The rarest and most worrisome situation is when an operation doesn't have approval. The reasons vary, but must be excellent, and that might not help. Operations without approval are conducted at great risk to lives and careers.

After final approval is the final planning and briefing. A flight itinerary is drawn up, documents are made, and an escape route is mapped out. If the "op" requires moving people, descriptions or holophotos are memorized. When the briefing ends, the Operations Director gives a personal briefing, and the agent is sent on his way.

Clones are occasionally sent instead of an agent. Clones are used on suicide missions, or missions when escape is an option, not a requirement. The clone is programmed with instructions to give himself a massive coronary, for example, if he is captured or fails. Of course, if the clone comes back, who gets the credit?

Because airships have superseded airplanes many nations no longer use planes to transport their people. Air Force jets can go to a nearby port, where a commercial flight is joined. Taxi and bus services are also used, especially when the mission goes to a small town or wild area.

Passing through Customs is the most daunting task. This is when an agent's acting ability, and the forgery talents of the documentation staff, are put to the test. Usually the agent gets through with no problems.

If the mission is a success, going back through Customs is a bigger concern. It's almost certain someone is looking for the agents now. The authorities may have descriptions. If the agents are moving someone, their documents may be checked more thoroughly. This is when technology can help. Micros or holos can misdirect. A quick clone can be made or an MMSD programmed. But as long as human beings man Customs stations, nothing works like a bribe or dirty pictures!

All these dangers are tempered by the fact that they don't happen every day, or even every week. A full month can go by between operations. And there are always more agents than missions, so no one will work back-to-back jobs.

Retraining becomes very important. Micros do help, but nothing works like a workout. Since stress and burnout do more damage than the enemy, no one stays around for more than three years before they either move to a station, get promoted to a desk job, or retire. No one has one of those "final" retirement plans; they tend to make it hard to recruit.

All the dangers so far discussed are fairly lethal. But there are other, less lethal, more menacing foes. They are the dreaded "inter-government rivals," the agencies whose turf sometimes crosses the agent's.

The worst of those opponents are agencies like the FBI. When it was first established, the FBI not only chased criminals but also foreign agents in the US. This no doubt continues in *AutoDuel* America. This is where most of the conflict lies.

Other assistance is easier to get, but in times of tight funds, it often has the phrase "you owe us one" attached. Stations and covert agents sometimes have trouble getting along, but try not to let it get out. If it does someone will get fired.

If all this appeals to you, you may want to set up an espionage campaign. Running such a campaign takes preparation. Will the players be on station, or will they be in the field? Who's in charge, a player or an NPC? The number of players doing the work won't be more than two. Then again, everyone could rotate between PCs and NPCs from adventure to adventure.

There won't be any lack of foes, unless you play the Canadians. Not only should there be plenty of action between the North American countries, but who knows what the Aussies, the Japanese, or the British are up to (empire, anyone?).

Since few agents make arrests, few will have Legal Enforcement Powers, and then only at the 5-point level. The Wealth level of most personnel is Average, but those from well-off families could be Comfortable. All agents with military service have at least three levels of Military Rank. Last, the agency is a Patron that appears on a roll of 6 or less. It's worth 12 points.

Agent PCs have strong Duties (-15 pts.). The total Enemies are not too numerous, won't come after them until they've done something, and are worth -20 pts.

Two Advantages/Disadvantages PCs shouldn't worry about are Appearance and Reputation. Agents must have fairly normal looks to be able to fit into crowds and allay suspicions. And only agents with long records will have a Reputation, and then only among knowledgeable agents.

Common skills for agents include Guns (many types), Driving (various), Survival (various), Disguise, Acting, Area Knowledge, First Aid Climbing, Tracking, Navigation, Parachuting, Swimming, Diplomacy, Fast-Talk, Law Tactics, Demolition, Escape, Forgery, Lockpicking, Shadowing, Stealth, and Traps. Other PC skills might come from military service or college.

Note that the skills lists will be quite long, and most skills will need to be at least at 13. 100-point PCs in this campaign might not be feasible.

Now for a sample adventure. "Run for the Border" is based on the **Sandbaggers** episode "First Principles," by Ian McIntosh.

## Run For The Border

### The Situation

Some six hours ago an Air Force high-altitude spy drone took off from White Sands Air Base, New Mexico. CIA stations in Austin and Oklahoma City have reported both countries were moving troops along the Red River border. The drone was sent to investigate. Its flight path would take it north of Lawton, around Ardmore, south of Wichita Falls, then re-enter the US between Lubbock and Midland-Odessa. The drone went down before it could cross the border and crashed somewhere between Lubbock and Abilene; it was not shot down. Its last reported position was fifty miles east of Graham Chapel (40 miles SE of Lubbock on Texas Highway 9E). No one was on board. The data recorders were packed to survive a crash or fire.

The mission is to go in, recover the recorders, and get all data off the drone. If possible or

necessary, the drone is to be destroyed. The Texans don't yet know it's crashed. Unfortunately, that part of Texas is bandit country.

### Working Out The Details

The first problem is getting in. However the PCs want to do it should be okay, so long as they head out from Santa Fe (a five-hour flight has been arranged by the USAF).

Next they must get to the scene. Taking I-40 to Amarillo then T-9 to the scene might work, assuming no one asks why they're going to Lubbock. A better try might be to enter at Clovis, NM. Either way they'll have to convince anyone they meet that their intentions are good.

One way to go in would be to parachute in and land within ten miles of the crash site. The trouble with this is getting a hold of a plane that moves slow enough to jump out of.

After they're over the border they should have some non-lethal encounters, like proud Texans, small time bandits, lawmen, or smugglers. Any of these might provide an ally, a clue, or nuisance. They will also test the PCs abilities in non-combat situations.

Once at the scene, the PCs will have a major dilemma: the drone looks intact, but closer examination reveals that it's been stripped. All the data recorders are gone!

The recorders and all the electronics equipment on board were removed by a local bandit gang. They're trying to figure out what they have, and debating whether or not they should go to

the authorities. (Turning over strange gadgets to the cops might get a respite from them.)

There will be at least ten gang members for each PC. Use the "Truck Stop" map for the bandit base or design your own (limit it to two buildings). Arm the gang with normal weapons like SMGs or LAWS. A vehicle ratio of one bike for every two gang members and one car for every twelve makes sense.

Yes, the PCs have explosives to blow the drone. But it doesn't take much to destroy a drone. (It's possible to use fuel or anything else from the drone as weaponry. Give PCs a character point if they think of it.)

If the PCs have freed the electronics from the bandits, the next task is to get out. Depending on how they did coming in and what escape plans they made, their escape should be marginally challenging. Hopefully they have good cover stories and haven't lost any documents or data during the battle.

If things didn't go well the PCs are in trouble. Getting out with a partial set of data might be easier, but won't make their bosses happy. If they're captured by the gang, they'll have two to three hours before the gang convinces the locals they have prisoners, and maybe another half-hour or so before someone comes to investigate.

If at any time they fall into the hands of the Texas authorities the adventure is over. They have been caught spying, and will no doubt get the death penalty, or, if they're lucky, life imprisonment. The CIA might make an exchange

for them, but that's not too likely.

Character points are awarded to each PC as follows: 2 points for getting all the data out; 1 point for getting part of the data out; 1 point (for the forgers) if the documents pass inspection; -2 for not getting any data out; -3 if anyone is left behind; -1 for failing to destroy the plane; and +1 (or more) for making and using allies

### Further Adventures

Because the above adventure is relatively easy, it makes a good starting point for a campaign. Other possible adventures include: the body of an agent turns up, and the PCs have to find out who killed him and why; an important official goes on an unannounced trip and meets with a member of the opposite sex, and they have to prevent a snatch or a defection; a wounded agent has to be smuggled out of hostile territory; and the ever-popular "foreign official wants to defect and we have to go get him" scenario.

Inter-governmental rivalry never explodes into violence; it's always a matter of out-lobbying, out-reporting, or discovering nasty things about your foe and making sure the right people find out. A top station agent may be doubling, but you just can't shoot him. You'll have to do some legwork and see who's pulling the strings. Challenge your players by giving them adventures requiring some thought.

Good luck, watch your back, and protect that pension! ■

### Voyages SF 15 Reader Survey

Readers are encouraged to complete the survey below. Either photocopy this form or list the article numbers, with appropriate ratings, on a post card. Rate articles: Excellent-4, Good-3, Fair-2, Poor-1, Not Read-0. Please mail completed survey by July 1, 1991.

- 1 \_\_\_\_ Commlink
- 2 \_\_\_\_ Recruiting For Paradise
- 3 \_\_\_\_ 20th Century Air-To-Air Combat
- 4 \_\_\_\_ Heroes Of Yesterday And Tomorrow
- 5 \_\_\_\_ Words To Game By
- 6 \_\_\_\_ Espionage Is Alive And Well In Autoduel America
- 7 \_\_\_\_ 2300 AD Ship Profile And Size Chart
- 8 \_\_\_\_ Idiots Don't Drive BattleMasters
- 9 \_\_\_\_ Reviews
- 10 \_\_\_\_ Graphics and Illustration

Q1: Is this issue better than, as good as, or not as good as our last issue?

Q2: Including yourself, how many people read this issue?

Q3: Rating in order of preference the most recent issues of the gaming magazines you read, where would you rate this issue of VOYAGES SF (1 is high)?

### VOYAGES NEXT ISSUE

#### Trouble On DM-738

A mini-adventure for RoboTech II: The Sentinals  
**The Bunker Hill Class Cruiser**

A starship for 2300 AD, with complete class vessel listing

#### Linkup

Cyberpunk fiction

#### An Obvious And Current Menace

An adventure for Merc: 2000

#### Helicopter Combat

Optional helicopter rules for BattleTech, including stats for modern day craft

**Plus Commlink, Words To Game By, and Game Reviews**

**Don't miss VOYAGES SF #16!**

# 2300 AD Ship Profile and Size Chart

*Don W. Shanks*

This project started out as just a simple aid for myself to build miniatures for playing *Star Cruiser*. I wasn't going for much detail originally, just getting the basic hull shape was sufficient. Over time, my drawings became more and more detailed.

Included in Digest Group's **MegaTraveller Starship Operator's Manual (vol. 1)** is a size comparison chart for the ships of that game. But they were just black silhouettes with no surface detail.

After seeing that chart, the focus of my chart changed to that of eventual publication, showing at least some surface detail of the craft presented. Another hopeful outcome of this article is that a miniatures company and GDW will get together to produce a line of *Star Cruiser* ship miniatures.

The size chart deals with different plastic tubing sizes used in making your own models. Just photocopy the size chart and take it to your local hobby shop.

Go to the area where sheet styrene plastic is kept for scratch builders and

model railroad modelers. You can pick up either the round or square tubing. Just make sure that the corners fit inside the circles for the proper size of that hull section. They should also carry "I", and other plastic angle beams. You will also, more than likely, need some metal tubing. (For example: You are building a model of the *Kennedy*. The cross piece of the spin capsules would be a small metal tube as well as the missiles on the rear hull.)

One of the simplest models to make will be the *Anjou* class freighter. Just cut the plastic tubing to the size shown on the profile sheet. Hollow out one end to allow fitting a small BB pellet. This makes the bow of the vehicle. Take a regular hand held hole puncher to a 0.040 thick sheet of plastic styrene. Then glue the round sheet of plastic to the other end of the *Anjou*. This now becomes the stern of the craft. Carefully score around the tube the engine compartment and the two side cargo doors. Then drill a mounting hole in the bottom center of the tube for a stand. Other than painting the model, the *Anjou*

is now complete.

I carved the *Aconit* class frigate out of balsa wood. I did the same for the hull of the *Exeter*, but cut up an index card to make the wings. With the Kafer ships, I have only managed to carve out a *Beta* class cruiser using modelling clay.

In the basic rules, it is suggested that you use golf pegs cut to size for either ships or missiles, and ping-pong balls as energy sources. Making your own models for this game is a great idea. And I have done so with some of the ships presented in this article. But some of the designs, especially the Kafer ships, deserve to be produced in metal. Wouldn't you like to have your own metal "*Alpha*" battleship or human *Kennedy* class cruiser?

*2300 AD* is not being supported as much as *MegaTraveller* or *Space 1889* are currently. *2300 AD* players will have to become more vocal about getting product support in the form of miniatures (25mm figures or ship miniatures). Write to GDW about this and let's see what happens. ■

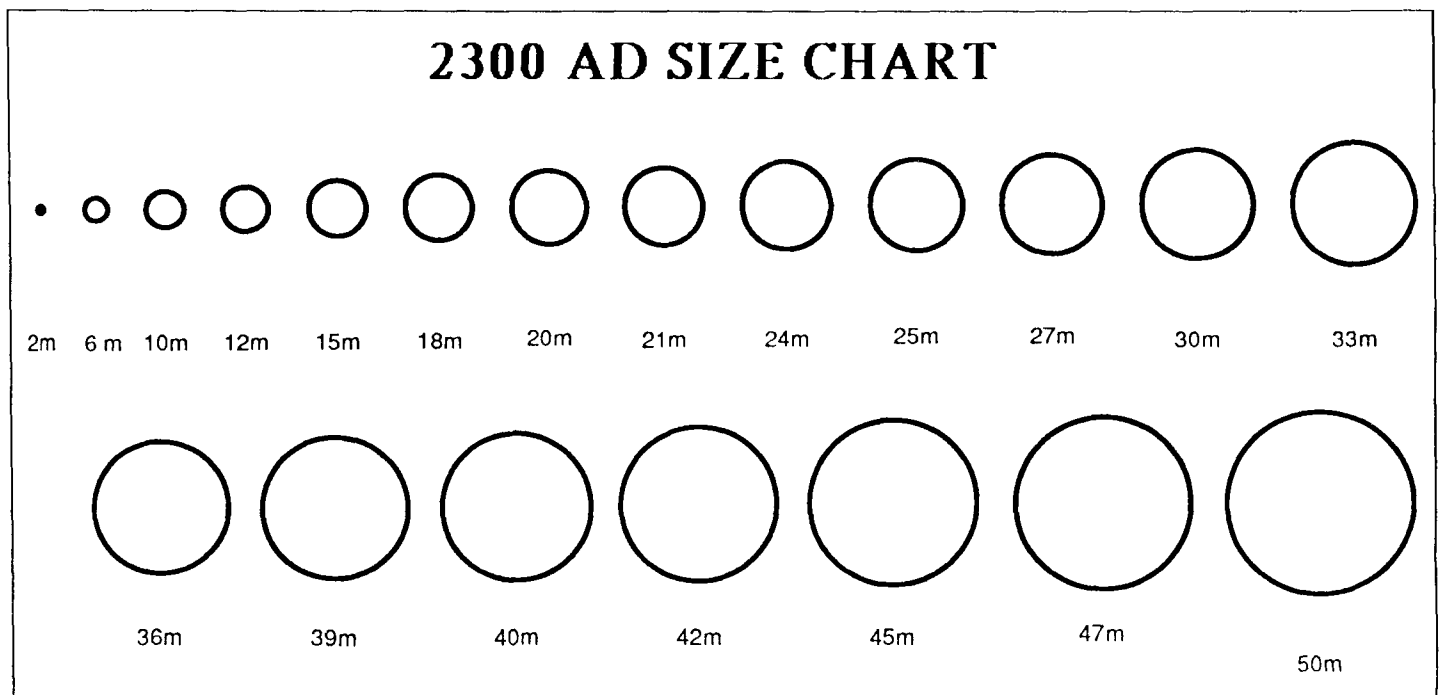

KIEV-clS Destroyer

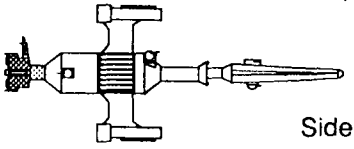

Side

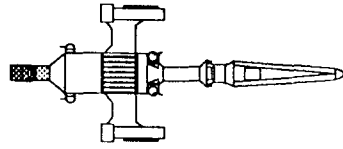

Top

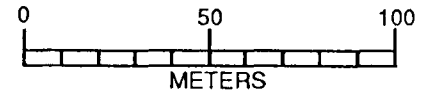

ACONIT-clS. Frigate



Side

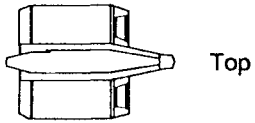

Top

SUFFREN clS. Cruiser

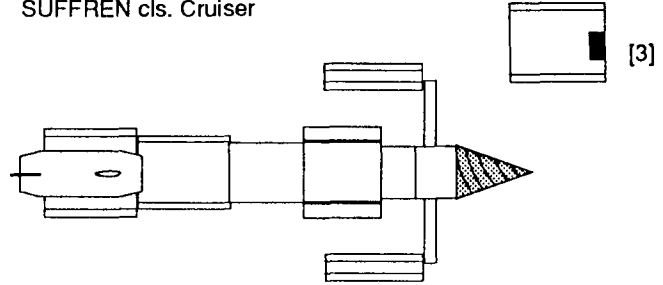

[3]

SUFFREN Lander (top)



[3]

CAYUGA-clS Close Escort

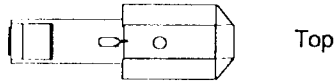

Top

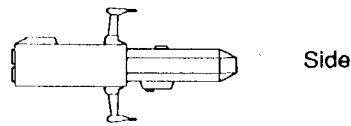

Side

TULA-clS. Frigate



Side



Bow



Stern

LC--20 ASF Combat Lander



Top



Side

THOREZ-clS Courier

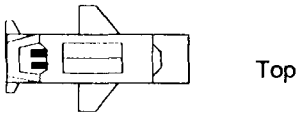

Top

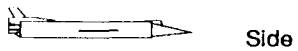

Side

CIT-III A -clS Interface transport

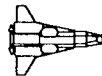

STALHAMMER-clS Utility Starship

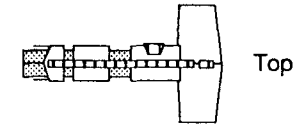

Top



Side

KILLIECRANKIE-clS Intruder Scout

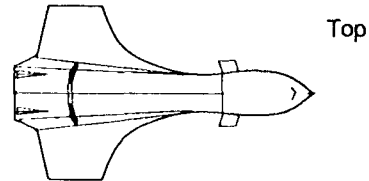

Top

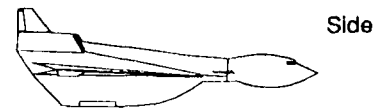

Side

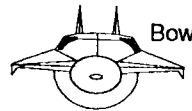

Bow

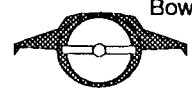

Bow

Cut-Away view of Grav. Drum

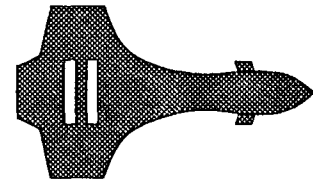

EXETER clS.-SDB

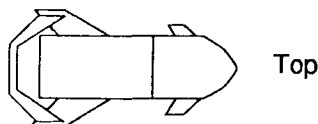

Top

ANJOU-clS freighter



Top

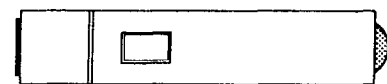

Side



RICHELIEU cls.- Battleship

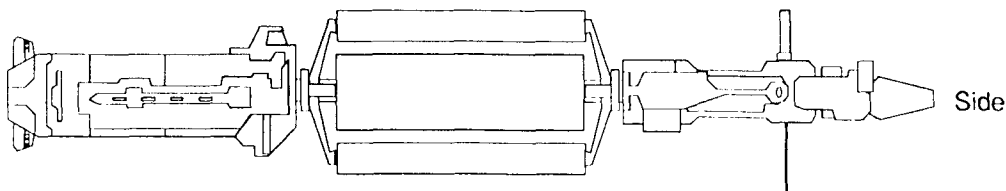

BISMARCK cls.- Battlecruiser

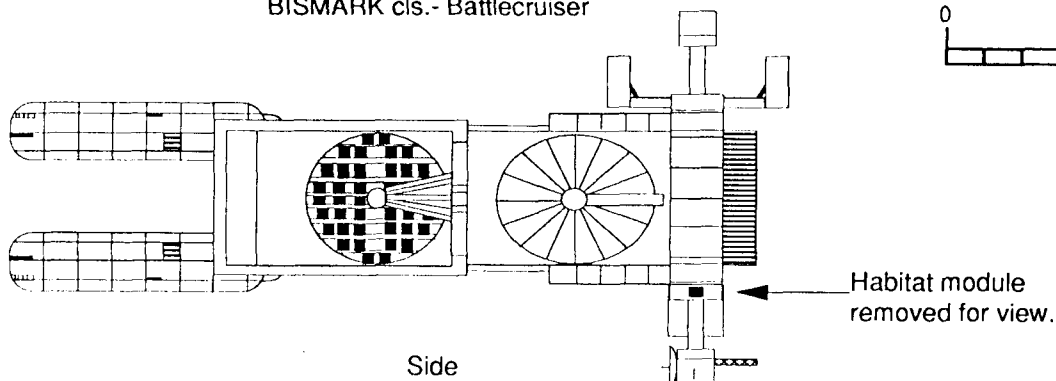

HAMBURG--cls Missile Cruiser

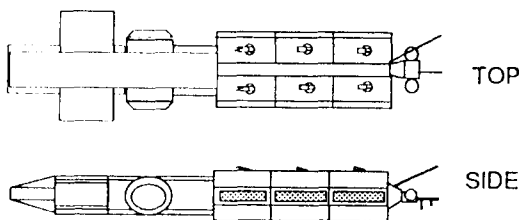

KENNEDY--cls Cruiser

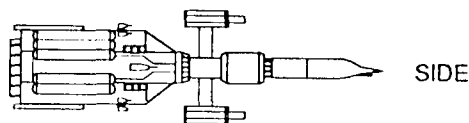

KRUPP cls.- Cargo Carrier



BC--4 cls. Freighter

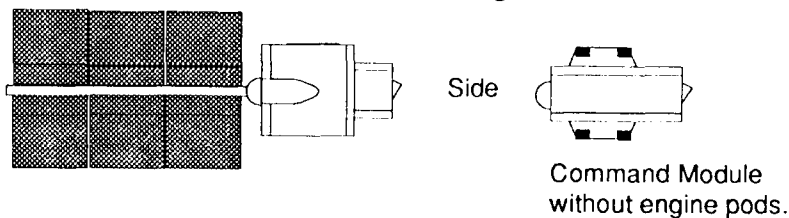

v.1 @ 21 m dia.

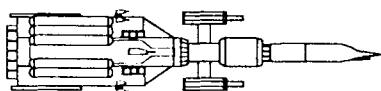

Version One is out of the book at 100m length and 21 in diameter. It doesn't look quite right by the paintings and drawings released so far in publication.

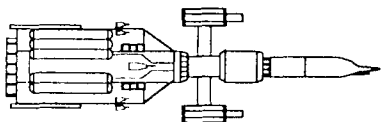

v.2 @ 30 m dia.

Version Two is the same length, but the spin habitats now rotate at 30 meters and comes closer to the box cover painting on STAR CRUISER.

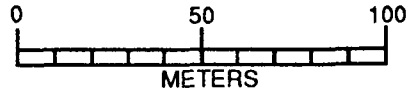

YPRES-12 cls.- Frigate

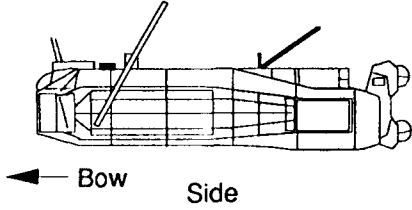

COMMERCANT cls.- Drop Cargo Carrier

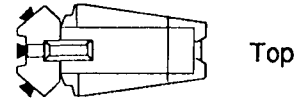

U.S.S. IWO JIMA cls- Assault Support Ship

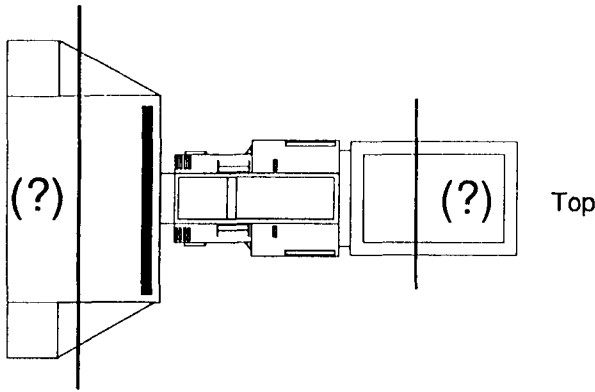

carries (3)

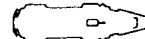

Can carry (2) LC-20s in external brace.

Ft. BLISS cls.-Destroyer

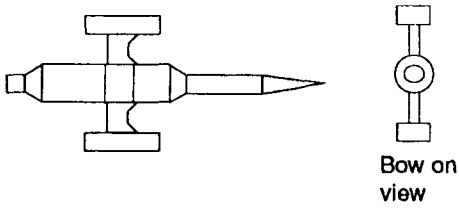

KONSTANTINE cls.-Cruiser

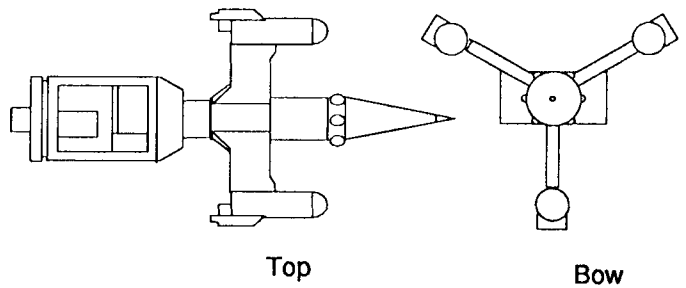

NEW ORLEANS cls.- Liner

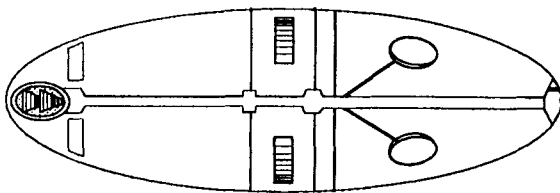

HUDSON cls.- Cargo Carrier

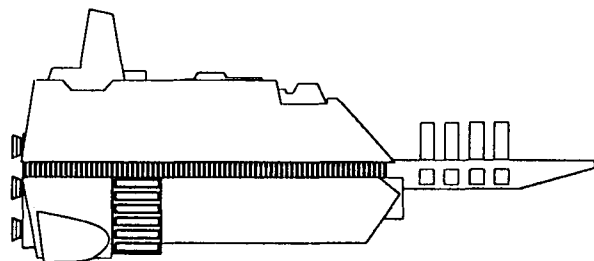

# KAFER SHIPS

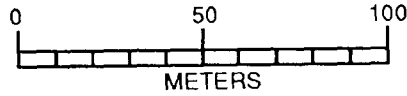

'BETA' cls- Battlecruiser

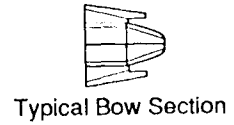
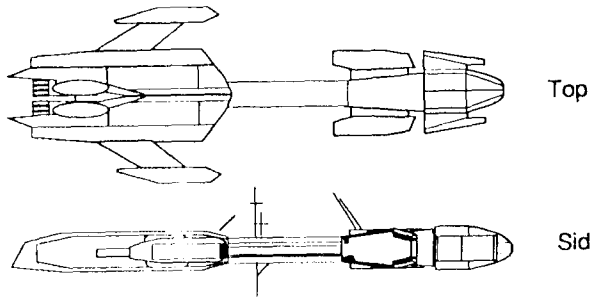

BATTLECRUISER Bow

"Delta" -cls Battleship

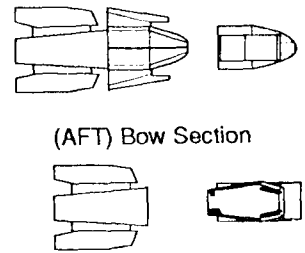
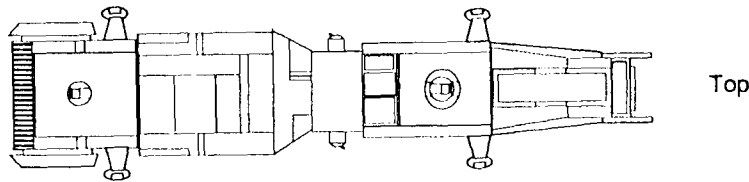

ALPHA / IMPROVED ALPHA cls. Battleship

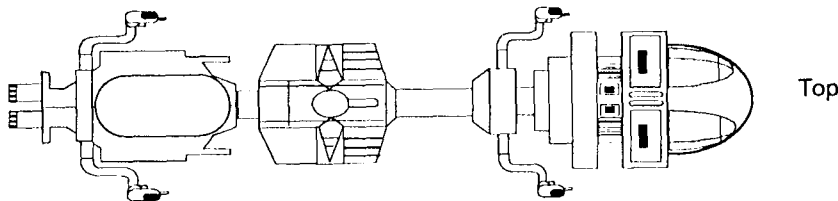

'EPSILON' cls-Cruiser

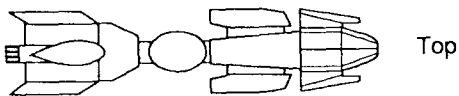

'OSCAR' cls-Transport  
with (2)  
'LIMA' cls- Landers

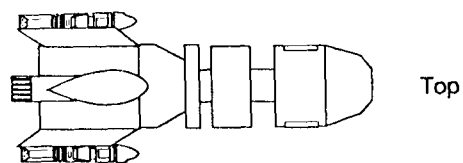

'OSCAR' cls-Transport

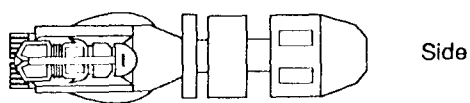
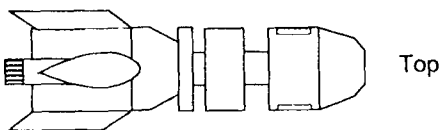

'LIMA' cls- Lander



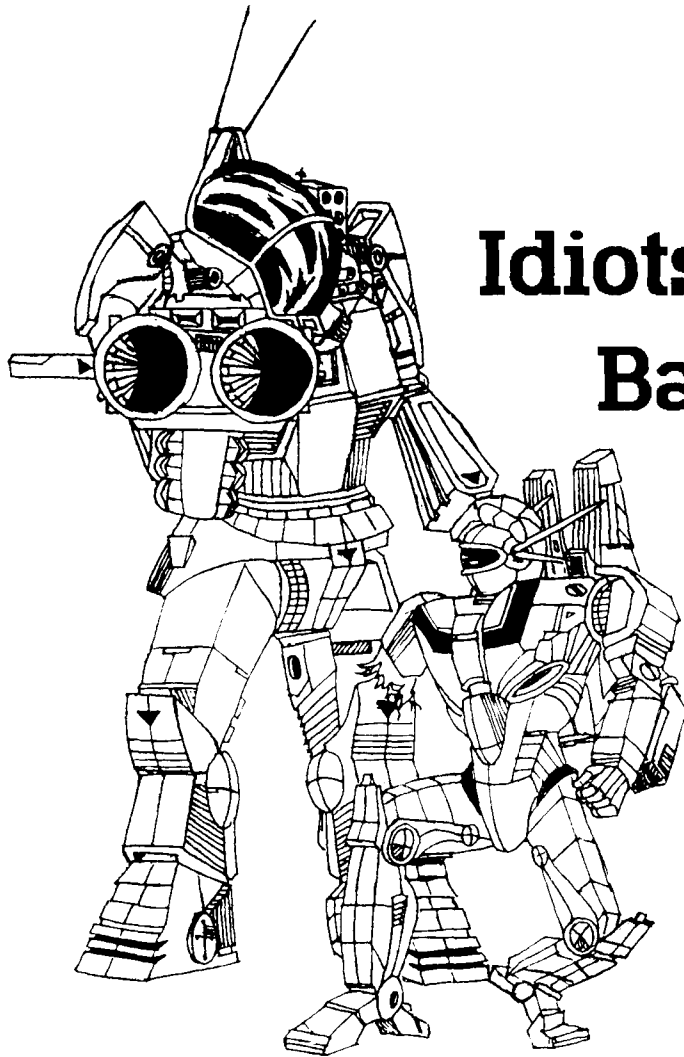

# Idiots Don't Drive Battlemasters

Battletech fiction  
by  
Kevin Hodges

"Idiots don't drive Battlemasters."

"What?"

"Battlemasters. You know, big tall things, lots of guns?"

"Yeah."

"They don't let idiots pilot them. That's why swarm tactics will never work. You know, some people actually go for these swarm tactics... you know, Captain Mercer Ravannion's infamous 'Charge of the Horde'? Sure, those tactics look great on paper, but I'll tell you one thing, and this is from the bottom of my heart, the tactic isn't worth drek.

"Oh sure, what about the success stories we hear every once in a while about a light lance overwhelming a larger opponent because of their '...superior speed and maneuverability...' Well I've got a story of my own that you won't catch on any House newsnet, it's not glorious or particularly melodramatic, but it tells the truth..."

I was commanding a light recon lance working in conjunction with Lindon's Company in the Marik takeover of the Steiner planet of New Delhi. We had been assigned as advance recon and cleanup crew in the recently evacuated city of Salasville; I'll never forget the place.

The city offered a great tactical advantage because of its location and the fact that DataDart Communications had a major research facility there. Not that we expected the retreating Steiner forces to have left us much of anything of any technical value.

Presumably, the city was completely empty. But who believes intelligence reports anyway, right? It was our job to patrol the city and make sure there would be no resistance when HQ was moved.

The five of us made up a pretty effective recon lance, my Hermes II, Bill in his beloved Wasp (affectionately named 'Killer'), Janie's Phoenix Hawk, and a new kid by the name of Jerome piloting another PXH-1. In the lead, as always, was 'Crazy' Bob Hillock driving that ridiculous Hellbreaker scout hovercraft.

We were doing the standard grid pattern, crisscrossing the city with our sensors on full active. Granted, the building structures were screwing with most of what we had, drastically reducing sensor range, but that's life in the big city folks. The streets were depressingly empty. I got the feeling I was searching through a ghost town. Even the passive electricity had been shut off, leaving the city in a blanket of uneasy darkness.

We were just passing the remains of a mini shopping mall, apparently hit in one of our earlier aerospace raids, when Janie picked up a small heat source a couple blocks up.

Crazy Bob pulled ahead of us to investigate, gunning the engine of his Hellbreaker to close the distance on the offending heat signature. The rest of us cautiously began walking that direction as Bob, now more than three blocks away, rounded the corner, out of sight. That's when things began to get out of hand.

Incoherent babble started coming over our

commlinks as, seconds later, Crazy Bob came burning back around the corner at full throttle screaming, "Holy Moses it's a graggin' Bat\*%(\*!!\*#\*..." The link went dead as a streak of red lit up our infra screens and the distinctive off color of a Martell medium laser unceremoniously vaporized our compadre.

Leaving the rest of us in stunned silence, Janie moved her Phoenix Hawk into a full run, yelling over the comm as she streaked toward the alley so recently vacated by our illustrious Hellbreaker pilot, "Computer says trajectory angle of 39.4. It's got to be an Assassin. Come on guys, *move!*" She buzzed past the dead streetlights and leapt over the holes in the pavement where some of our stray bombs had gotten an intimate view of the city's sewer system. She must have hit the corner at almost 90 kph. She somehow managed to make the turn and quickly disappeared from sight.

Cursing rather fluently in the realization that we were now forced to advance, I gave the order. Jerome had a head start with Bill only a few meters behind. I was starting from a bad position and they, consequently, had a good 120 meters on me.

We had not yet had radio contact from Janie but the way the buildings across the street were lighting up I could tell something awfully big was going on down there.

I was attempting to raise Janie on the comm when Jerome hit the corner. There was the unmistakable blue lightning of a particle projection cannon. The bolt caught the new boy square

in the head and in the resulting explosion there could be no hope of survival. Jerome's mech was still moving under momentum, but, without a pilot, much less the controls, it toppled unceremoniously and tumbled and slid another 60 or so meters and crumpled against the front wall of city hall. And in that slow motion semi-awareness of battle, I could see the sparks of the metal on the pavement, the flashing fire, and ripped support mounts around the writhing wires, still alive, inside the limp mech.

It was a credit to Bill that he didn't suffer the same fate. He managed to fire his jumpjets and fly over and to the side of the explosion. Bill's improved view of things from the air apparently gave him a view of our adversary because, as I saw the brief flash of his own laser, one word came bursting from the comm, "Battlemaster!"

39.4 degrees at 67 meters, I thought ruefully, the precise angle of fire from an ASN-21 Assassin...or a crouching BLR-1G Battlemaster. We were in deep doo doo. Slowing my mech before I reached the corner, I hugged the building and eased around slowly. What I saw stopped my heart.

Janie had apparently come around the corner at high speed and ran straight into the extended hand on the awaiting Battlemaster. The impact had severely damaged her left shoulder and, understandably, left her on her touche. After releasing, by the looks of Janie's mech, a full frontal salvo that had blown off her right arm, the BLR pilot had then held the Phoenix Hawk down with one hand, and, with her thus neutralized, blown the head off of the late Mr. Jerome's Phoenix Hawk. The BLR pilot was now moving the barrels of the PPC towards the head of the pinned, frantically squirming Phoenix Hawk to finish the job.

Triggering my flamer, I had the satisfaction of seeing the top of the Battlemaster engulfed in orange fire as I brought my autocannon to bear on monster, catching him in the arm holding the particle cannon. Well, now that I had his attention, what the hell was I going to do with it?

The Battlemaster raised the PPC and I only barely dodged enough to avoid getting my own head blown off. The blast instead caught me on the right side of my torso and the explosion spun me violently around. I stabilized just in time to receive a full volley of short range missiles that caught me in a diagonal pattern from my right leg to my left torso. Torqued in the opposite direction of what I had been compensating for, I lost control and hit the pavement.

The torso of the huge mech rotated towards me as I scrambled desperately to my feet. I just managed to roll around the corner of the building as a rapid-fire pattern of laser fire hit the side of a building and melted a stop sign a couple of meters in front of me.

The volley was suddenly cut short as a series of explosions ripped through the alleyway. Risking myself for a look I bolted back across the alley with my autocannon on full fire. Janie had taken advantage of the distraction I had caused and jammed her remaining fist into the groin area of the Battlemaster and simultaneously triggered her arm-mounted machine guns, temporarily disrupting the pilot's concentration and forcing his attention back to her.

My cannon fire missed him completely but I had time to notice Bill, who had jumped on top of the building behind the Battlemaster and was opening up on its exposed back with laser and SRM fire.

Janie had now managed to get back on her

feet and super-heated air was being expelled from her jumpjets in a frantic effort to take off. She got maybe thirteen meters straight up when, in the most incredible move I've seen a mech pilot accomplish, the Battlemaster's left arm shot up and grabbed the Phoenix Hawk's right ankle. Janie's mech twisted grotesquely as her jumpjets tried in vain to compensate for an 85 ton anchor. Realizing that if I didn't do something soon her jumpjets would give out, I launched my mech into a flying tackle catching the Battlemaster in the knees. Bill apparently had gotten the same idea and as I crashed headfirst into the legs of the huge mech Bill leaped off the top of the building and came down on the massive torso behind the head. The combined force of our collisions caused the Battlemaster to release its grip. The resulting crash was deafening as the Battlemaster tumbled heavily onto the pavement, pinning my right leg and flinging Bill a good eighteen meters and onto his back.

With the sudden release, Jane shot straight into the air and went down out of sight behind the building Bill had recently vacated.

Bill's Wasp recovered quickly, scrambled to its feet, and began running full-out away from the Battlemaster. After a moment of stunned realization I began screaming after Bill, struggling valiantly to pull my leg out from under the massive bulk of the BLR and then, in desperation, squeezed off several shots from the autocannon into the side of the motionless hulk.

The fall must have temporarily disabled the pilot of the Battlemaster because it took several seconds to finally roll the immobile hulk off of me and to stand up. Janie had recovered nicely and was now only a few meters away on the other side of the BLR, cautiously covering it with her remaining laser. Bill had ducked around a street corner about 150 meters away and was peering carefully back around at the inert form.

The victory was short lived. As I brought my autocannon up to its head, the Battlemaster's left arm shot out and grabbed my knee. Using me as leverage, the enemy pilot rolled his mech into a sitting position and triggered his PPC point-blank at Janie's Phoenix Hawk. The bolt passed between her arm and her torso and the ionized particles slammed into the building behind her, showering all of us with debris.

Thrown onto my back, again, I twisted out of the mech's grip on my leg and three explosions rocked the Battlemaster as all three of us hit the huge mech with three separate medium laser pulses. I followed this up by mercilessly covering the left side of the BLR in fire from my Olympian flamer. Disappointingly, the damage had little effect on the Battlemaster's heavy armor and he got to his feet.

You know, you never really realize just how big a Battlemaster is until one stands up next to you. I backed my mech up into optimum range for my autocannon and, and he was rotating to face me, hit the mech square in the center torso. Yeah, I know. Of all the places I could hit a Battlemaster, it had to be the center torso.

The Battlemaster completed his turn and was now facing right at me. It was with extreme regret that I realized that optimum range for my autocannon was, coincidentally, optimum range for his Donal PPC. Yeah, I know that, too. Never, ever, stand in front of a Battlemaster at close range. My foe was temporarily obscured in a flash of bright light as he simultaneously fired all four medium lasers, his PPC, and his SRM six rack.

The wide spread of the damage was the only thing that saved me as the devastating volley

melted most of the front of my Hermes. There was a gaping hole in my left torso where the PPC had connected, and the missiles had left the actuators in my right leg flapping in the breeze. Amazingly, I had managed to stay on my feet.

The Battlemaster advanced toward me, negligently shedding laser and chain gun fire from Bill and Janie. Realizing that his fire was having little or no effect, Bill fired his jump jets and flew in a smooth arc, cutting his jets at the top of the arc to build up full speed for a death from above attack on the unsuspecting BLR.

Janie had her chain guns set for autofire and was staying right behind the Battlemaster trying to divert its attention with steady laser and MG fire while Bill made his descent.

Bill came hurtling out of the sky and ploughed into the Battlemaster's shoulders in a spectacular crash. Twenty tons of flying steel is something to be reckoned with, even for an 85 ton monster, but it seemed the Battlemaster, after a brief struggle to keep balance, merely shrugged it off. Bill had not so much crashed into the BLR as bounced off. The Battlemaster reached down and latched on to the Wasp's wrist. Dropping the PPC, it brought its other fist down into the chest of Bill's mech, caving it in and seriously disrupting the gyroscope housing.

I started running towards the engaged duo but stopped short as what happened next sent a chill down my spine. The Battlemaster stopped pummeling my downed friend and grabbed the Wasp by the upper leg with his free hand. He lifted Bill, who was punching for all he was worth with his free left arm, off the ground and over his head. With what must have been a colossal effort, the BLR hurled the struggling mech over fifteen meters before it slammed headlong into a nearby building. The Wasp went through the wall and lay collapsed inside. A couple of well placed laser shots from the Battlemaster brought the rest of the heavily damaged six story building down on top of Bill's mech, leaving me only a brief glance of his left foot visibly protruding from the rubble before the ensuing dust cloud obstructed all but sensor vision.

Well, call us cowards, but Janie and I took that as a sign from God, turned tail, and ran like Lucifer himself was after us. Probably, the only reason we got away was because the dust cloud made laser fire all but impossible and the fact that the Battlemaster pilot no longer had a grip on his PPC.

I can't tell you how glad we were to get out of there. Soon after that fiasco I retired and sold what was left of my mech to my company, and I've never gone back to that godforsaken planet. Janie stayed on though, and I heard she's gotten herself a promotion and is running a light recon company for Colonel Lindon now.

I suppose it ended on an uplifting note, however, because a couple of days later they dug out Bill's Wasp. His cockpit had survived the collapse of the building and Bill, though a bit bruised up was alive and had survived on emergency rations for three days.

They never caught that Battlemaster though. Somehow he got back to his own lines and presumably left with the retreating Steiner forces. I'll tell you, anyone who can avoid a prolonged pursuit in a Battlemaster is a god in my eyes. I never even found out what the guy's name was.

So, that's why swarm tactics will never work against big mechs like that, because of the people who pilot that kind of mech. Don't mess with the elite, chummer. ■

## Cadillacs and Dinosaurs

### The Roleplaying Game

144 pg book. \$18.

*Design:* Frank Chadwick. *Cover Artist:* Mark Schultz. *Interior Artists:* Mark Schultz, Steve Stiles, Kirk Wescom, Steve Bryant.

*Publisher:* Game Designers' Workshop, P.O. Box 1646, Bloomington IL 61702-1646.

*Cadillacs and Dinosaurs* is the latest roleplaying game using the rules from GDW's popular *Twilight: 2000* system. It is based on the comic series *Xenozoic Tales*, created and drawn by Mark Schultz. Like its predecessor, *Twilight: 2000*, the game's background is based firmly in a post-holocaust era, with mankind struggling to survive in a world even more insane (to the man on the street) than the radioactive wastelands that follow World War III. But, though the basic idea behind both games is similar, *Cadillacs and Dinosaurs* holds more hope, and is really more believable. In *Twilight: 2000*, everyone should be

perishing in a new Ice Age, sparked by nuclear winter. In *Cadillacs and Dinosaurs*, the homeland of mankind flourishes in a new age of life.

### ECO-ARMAGEDDON

Instead of destroying its world with a bang, as in *Twilight: 2000*, mankind urges the world into a frenzy of change with its ecological devastation. Unfortunately for mankind, this change takes the form of violently destructive ecological upheaval as the atmosphere warms with the greenhouse effect, the ice caps melt and shorelines recede alarmingly. Added to this are tectonic events of colossal size, reshaping the Earth's surface. Mankind barely has enough time to construct huge underground shelters in geologically secure areas to wait out the change. This happens in the year 2020.

### CHANGES

By the time men emerge from the few shelters left functioning, six centuries have passed. Some of mankind's views have changed, thanks to secret association with a subterranean race known as the Grith. The Grith predate humanity, and have learned to live with nature rather than conquer it. Most of the mechanics who maintained

the life-giving machinery of the underground shelters accepted a Grith-inspired view that man also could exist in ecological harmony. Their importance to mankind's survival has colored the thinking of the groups that returned to the surface, and now any plans to expand man's dominion on the planet are largely viewed from the point of ecological impact rather than profit.

Of course, the world they found changed some, too. A large number of once-extinct species of animals and saurians have appeared in the last six centuries, while the land is now marked by volcanoes, shallow seas, and strange tropical vegetation (with temperatures to match). Watching the Rite of Spring piece from Walt Disney's *Fantasia* pretty much describes the topography, flora and some fauna. Fortunately for his survival, mankind actually meets dinosaurs when he has firearms to protect himself.

### PROBLEMS

Unfortunately for the dinosaurs and other animals roaming the planet, mankind has firearms to protect himself. Some go beyond protection or shooting for the pot, as animal and dinosaur parts become valuable commodities and the practice of poaching rears its head. This is one of the driving themes of the comic series' drama, as the hero fights for the survival of dinosaurs which seem to



Cadillacs and Dinosaurs art copy. 1990 Mark Schultz



be a threat to his own survival.

Of course, there are other things PC heroes can do besides fight poachers. Little of the North American continent has even been explored — the only two major settlements mentioned in the comic series are The City in the Sea (formerly New York) and Wassoon (built on the remains of Washington, D.C.), with wilderness in between. There's a whole continent to explore, with the possibilities of meeting other tribes (including reports of Amerind-like tribes in the interior), of finding technological treasures still buried in shelters over half a millenium old, of settlement wars, of "thrilling adventures in a world gone mad!" as the cover states. And trying to survive in an environment literally crawling with toothy things that include man on the dinner menu.

*Cadillacs* has possibilities. Consider the idea of having a bunch of *Merc: 2000* characters preserved in some sort of cryosuspension or other stasis *deus ex machina*, to be released by a scavenging party in the year 2600+. Or perhaps a group from *Twilight: 2000*, rationalizing that the nuclear holocaust caused a global warming rather than a 10,000 year Ice Age. Since the game systems are interchangeable, this is possible (good luck getting ammo for those caseless rifles and heavy weapons, though...).

## EVALUATION

As I just noted, *Cadillacs* has possibilities. With a little bit of work, a good gamemaster can make a good campaign for this game, and the players will certainly have to use their wits rather than their trigger fingers when confronted by a multi-ton monster from the Cretaceous Era. Even the huge .460 Weatherby Magnum rifle, practically a light anti-tank rifle, has only a fifty-fifty chance of stopping a Tyrannosaurus Rex with a good shot. Both internal and cover art are true comic-book quality, something usually lacking from game art (game companies can't pay as well as the comic industry). Of course, the majority of the artwork is taken straight from *Xenozoic Tales/Cadillacs and Dinosaurs*, done by Mark Schultz. Schultz is

a fan of the styles of Alex Raymond and the immortal Wally Wood (one look at his women confirms the latter).

The art and concept may be good, but *Cadillacs* is an incomplete game. The book is divided fairly equally between background and rules, and doesn't have the space available for the rules that *Twilight: 2000* has. The background material is good and I'm sure that it is faithful to the series, but it is rather limited in comparison to the backgrounds and campaign settings provided in other RPGs. Perhaps a bit more development could have been provided by the author, in collaboration with Mark Schultz. As it stands, the campaign setting is rather limited to The City

in the Sea, Wassoon, and their outposts. Additional development would have required additional space, but would have been worth the price.

Likewise, the rules needed more space, and perhaps a bit more thought. I could find no rule for the effect of armor on hand weapons — surely a knife has less effect on a dinosaur than on a human! Stats for the M72 LAW were included, but the author didn't bother to figure what happens when one hits a dinosaur. As it stands, a direct hit with a LAW barely dents a dinosaur. While very little of a LAW's damage potential transfers to a person because a man really isn't dense enough to make it explode, a multi-ton dinosaur should have the mass to cause a messy incident when the LAW hits. Critical rules for combat were left out, small sections that could have been added, and did show up in **Challenge #47**: The section on killing shots should have included the sentence "If the die roll is less than the damage value of the shot **or the Small Arms skill of the firing character (whichever is less)**, the animal is instantly killed." (Bold type indicates the words left out of the rule in *Cadillacs and Dinosaurs*.) Also forgotten was the section on Target Size, making hitting a prehistoric monster the size of a truck as difficult as hitting a man-sized target. And what does the abbreviation "Blk" stand for in all the firearm listings? No explanation is ever given.

*Cadillacs and Dinosaurs* is 144 pages at \$18. *Twilight: 2000* is 280

## REVIEW IN BRIEF

**CADILLACS AND DINOSAURS=2.6**

Game Complexity: *Medium*

**RULES=2.6**

Clarity=2.7

Realism=2.5

Flexibility=2

Playability=3

**DEVELOPMENT=2.3**

Background=3

Technology=2

Scenarios=2

**PRODUCTION=2.8**

Cover Art=3

Interior Art=3.5

Layout=2.5

Editing=2

Charts=2.5

Record Forms=3

pages at \$20 for the softbound book. For an extra two dollars, *Twilight* is twice the size of *Cadillacs*, with a lot more rules. Perhaps *Cadillacs* should have been enlarged to include all the necessary rules and the price raised a couple of dollars. It would have been worth it.

*Cadillacs and Dinosaurs* looks as if it were hastily written and assembled, without adequate time for playtesting (no playtesters are listed) and solving little problems like those I mentioned. Perhaps an errata pamphlet could be published in **Challenge Magazine**, as adventures for the game are sure to appear there. I intend to try my hand at writing some adventures for the game myself. I like the ideas and concepts (although Schultz's rabid eco-view of minimal intrusion gets a bit old, like the "save the whales" business in **Star Trek IV: The Voyage Home**). I prefer consciously-managed wilderness myself.

On the whole, one thumb up, one thumb down. The game has promise, if GDW can patch the holes in it.

— Craig Sheeley



## Central Casting: Heroes for Tomorrow

Character creation system for  
science fiction RPGs

98 page book. \$11.95.

*Design:* Paul Jaquays. *Cover Art:* Paul Jaquays.  
*Interior Art:* Paul Jaquays, Zachary Jaquays.

*Publisher:* Task Force Games, 14922 Calvert St,  
Van Nuys CA 91411.

*Heroes for Tomorrow* was created for the purpose of developing very complete back-grounds for science fiction RPG characters. It can be used for NPCs as well as PCs, although player characters will get the most out of this book.

The rule book requires several types of dice: d4, d6, d8, d10, and d20. The introduction explains how to adapt what you get out of this to your favorite game system. You can use the charts to generate a character completely from scratch or just to create a background for your character. The charts cover all sorts of interesting things: Culture and Social Status, Parents and NPCs, Special Events of Childhood, Occupations and Attitude/Alignment. All of your dice rolls and decisions are recorded on the handy form provided. When it is filled out, you take the hard data and write out your character's history.

I like the whole concept of this book. It is put together well and flows in a logical progression. I also liked the fact that you are reminded to use book marks to find your way back to the last chart you used because it is possible to go from one chart to any of several others. Not all authors would bother to even make the suggestion and it's a nice touch.

One of the nice things about *Heroes* is that you don't have to follow the chart if you roll something you don't like. Just pick something else or roll again. The idea here is to build a background for your character so you know what he/she is like — not to force the character into a random mold. I used the book as a catalyst to start the creative juices flowing. There is one possible drawback, though. You can get really wrapped up in detailing your character's background. I think I spent 6-8 hours thinking and writing out the detailed background for my character.

There were some things I didn't like. In several places I created numbers and got information for a term whose definition was not as clear as it could have been. An example was this cryptic phrase: "102B: Culture (roll a d100 + TekMod)." I finally found out where to get my TekMod but it took a while. Actually, I went back and read the directions a little more closely than the first time and I found out what and where it was. But *Heroes* could have helped a bit more by giving a separate section devoted to the care and feeding of TekMods, FutMods, CuMods, SolMods, BiMods, etc. Some of the artwork was not very good, either. But remember that the charts are what this rule book is all about. The good art is just icing on the cake.

I like *Heroes* a great deal. Players can create a detailed background for their character without a lot of struggling. It's easy — just roll the dice and follow directions. But referees will like this book also, because they can create detailed NPCs with little or no fuss. And because the players know

how their characters were shaped and know what makes them tick, they can roleplay them with a higher level of proficiency. Also, the referee will have this information and can use it to bring old friends, enemies, or patrons out of the past to surprise them.

As I said earlier in the review, I like this book. I bought it. And I used it. Several players in the *Star Wars* campaign that I play in have used it also and I think it improved the player characters a bit. I certainly think it makes it easier to play my "Smuggler Tring To Go Straight." I now know why he does what he does. I just don't know where it's going to take him. I highly recommend *Central Casting: Heroes For Tomorrow*.

— Glen Allison

## The Flaming Eye

Campaign Sourcebook

104 page book. \$12.95 (MegaTraveller).

*Design:* Thom Gressman. *Development:* J. Andrew Keith, Joe D. Fugate Sr., Nancy Parker, Bill Hezeltine. *Cover Artist:* Michael Weaver. *Interior Artists:* Rob Caswell, Tom Peters, Blair Reynolds, Joe D. Fugate Sr.

*Publisher:* Digest Group Publications, 515 Willow,  
Woodburn OR 97071.

*The Flaming Eye* contains two complete, linkable campaign adventures. As a companion volume to *Alien Volume 1, Vilani and Vargr*, *The Flaming Eye* allows the effective and satisfying application of the information found in the first volume. The adventures use the successful Cinematic Nugget format used in *Knightfall* and are extremely well designed and thought out, virtually requiring nothing more from the referee than reading them before play. Alternate nuggets present several optional scenarios to cover the

possible choices and directions that are open to the PCs.

As a sourcebook, *The Flaming Eye* includes World Data Sheets for 26 solar systems in the Vland and Windhorn sectors, plus maps and data for several subsectors. These alone are worth purchasing the book if you want to roleplay in the Vland/Vargr region. As an added bonus, color deck plans of the Garu Class Type A2 Far Trader are located on the inside covers.

I found *The Flaming Eye* to be a very satisfying product. A lot of useful material is packed into its pages. And as an aid to roleplaying, it's simply hard to beat. For one, it is hoped that some of the players will be Vargr, and opportunities are repeatedly presented where Vargr PCs can apply the "alienness" of their character. Interaction with people of varying cultural biases is another roleplaying strength. Lastly, the adventures are written with the assumption that personally satisfying and rewarding roleplaying can be accomplished even when the whole point of the adventure — the costs, risks, and danger — is to help a single person or only a small number of people. To top it all off, the artwork is nothing short of excellent.

*The Flaming Eye* is a well rounded package worthy to be on any *MegaTraveller* referee's "buy list." Players will be pleased as well. The adventures allow a nice mix of skill needs — combat, merchant trade, espionage, craft operation, interpersonal, etc. If Digest Group continues to publish supplements of this high quality, *MegaTraveller* is going to be high on the popular games list for a long time to come.

— James B. King

## Merc: 2000

Background setting using *Twilight:*  
2000 rules

120 page book. \$16.

*Design:* Loren K. Wiseman. *Cover Artist:* Bob Larken. *Interior Artists:* Tim Bradstreet, Grant Goleash.

*Publisher:* Game Designers' Workshop, P.O. Box  
1646, Bloomington IL 61702-1646.

*Merc: 2000* is an alternate history sourcebook for GDW's *Twilight: 2000*. In this presentation a World War III nuclear holocaust doesn't happen. Instead, the political situation develops so that by the year 2000 a series of small wars, political uprisings, and terrorist activities are occurring continually. Political grudges, border disputes, and unrest are everywhere. Mercenaries are needed constantly to supplement and support anyone who needs them and has the money to pay for that support.

*Merc: 2000* uses the *Twilight: 2000* rules. Except for some minor rules additions, game rules are not included in *Merc: 2000*, but requires the use of *Twilight: 2000*.

There is a lot to like in this book. The halftone art by Tim Bradstreet and Grant Goleash (22 pieces) is great, although almost a little too dark for my taste. The maps are done well and the cartographer didn't try to cram too much onto each map (this probably explains why there are so many of them — 38 to be exact), which helps for



The Flaming Eye art copr. 1990 Digest Group Pubns.



## Tramp Freighters

### Galaxy Guide 6: Free-traders in the Star Wars Universe

80 page book. \$13.

*Design:* Mark Reinhagen, Stewart Wieck. *Cover Art:* Lucasfilm Ltd. *Interior Art:* Allen Nunis, Rob Caswell.

*Publisher:* West End Games, RD3 Box 2345, Honesdale PA 18431.

**Tramp Freighters** is a long awaited (at least by me) supplement that provides rules that have been needed since shortly after the release of *Star Wars: The RFG* back in 1987. As I stated in "Long Term Star Wars," in **Voyages SF #12**, *Star Wars* needed trade rules and starship operation rules with data on the various costs. This book even gets rid of that ridiculous rule that requires a player to expend skill points and money to improve starships (well, the authors say that rule is ignored in the campaign included in the book, but I doubt many gamers would really go back to the previous rule).

Rules for speculative trading (the risky venture of buying and selling your own cargoes) and drop point delivery (hauling for agreed upon fee) are provided, as well as rules for the more lucrative (and far more risky) black market. As PCs are hardly likely to have the cash to purchase a ship outright and banks shy away from loans for light freighters, rules for working with loan sharks are included (as a referee, this section sure brought a smile to my lips!). Rules for maintaining, modifying, and repairing light freighters round out the rules section. These rules are very successful in accomplishing what was intended, and still maintain the atmosphere of *Star Wars*.

My only complaint is that the rules are written for operating light vessels only. If your players get a vessel of medium size (as my players aspire to), you'll be altering the rules.

The second portion of the book is a campaign set in the "Minos Cluster," an Imperial backwater where both the Empire and the Alliance hold less sway. The campaign can be played in two ways: the PCs are not yet members of the Alliance (which probably means starting with new characters) or they are hunted felons with a high price on their heads (successful members of the Alliance) who run to the Minos Cluster to hide, basically losing their rebel contacts for a while. Either way, the PCs are free to conduct themselves as free traders and, just as important, must fend entirely for themselves. Events in the campaign slowly bring the needs of the Rebellion back into play.

Information about law and order (crime and punishment, the Imperial perspective) and all other sundry ways in which traders must deal with the Imperial bureaucracy in the cluster is included (so much for avoiding Imperial "entanglements" — yes it's true, these things sully the satisfying, carefree life of a free trader even more than do pirates). This can be altered to use throughout the Empire.

**Tramp Freighters** is a book I have long waited for. I place its importance to the success of my own campaign above most all other *Star Wars* supplements, including the *Imperial* and *Rebel Sourcebooks*. It even provides some examples, beautifully illustrated, of vessels that the players can use to design their own, most of them modified from the standard stock light freighter (one of my own players originally preferred not to have a stock light freighter because of too much familiarity with the *Millenium Falcon*).

*Star Wars* gamemasters, you've got to have this book.

— James B. King

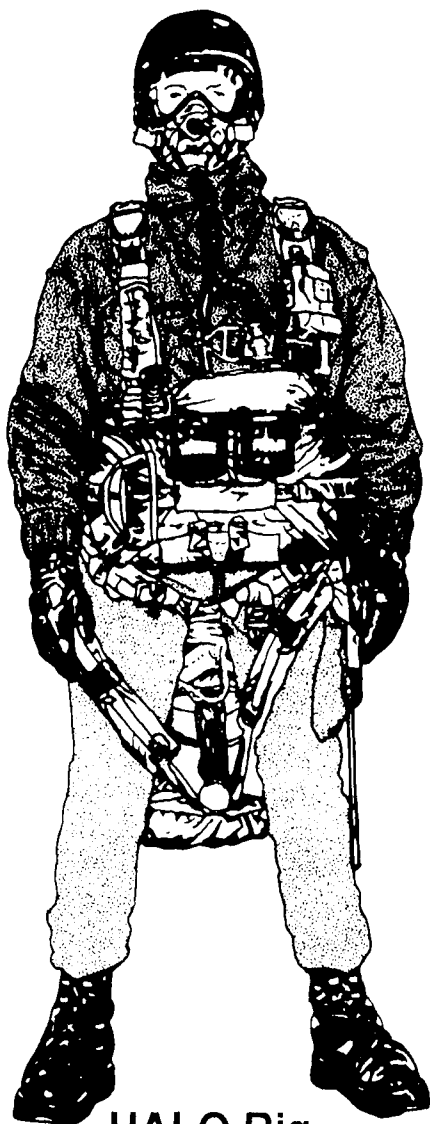

HALO Rig

clarity. The equipment drawings (41 illustrations) are fine but a bit plain. They do show all necessary details, though. I also like the ten brief adventures provided. There are plenty of ideas to get any referee going with little trouble.

There is little that I dislike here. I wish there was a little more material to it, but then, I always want more, more, more. Also, I thought the section titled "The World of 2000" was a bit too brief. 1.25 pages is not much to give any detail to the state of the world in 2000. And it is too bad that you need another \$20 game to really play this one.

If you are a referee and you already have *Twilight: 2000*, you would do well to get this book. The extra equipment and new rules are useful even in a post-holocaust world. If you would rather not deal with the results of a nuclear WW III and don't want to do the work to recreate a new and believable political situation for *Twilight: 2000*, then this book is for you.

— Glen Allison



Tramp Freighters art copr. 1990 Lucasfilm Ltd.

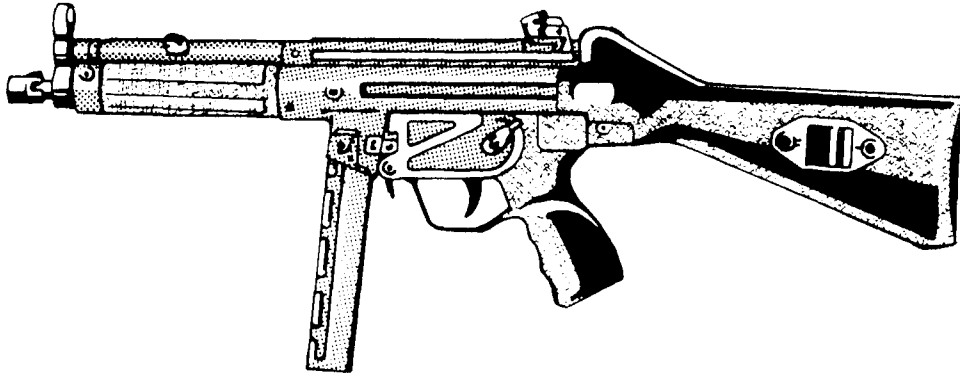

## Armored Reserves

80 pg book, 1 sheet full-color counters (180) \$15  
(*Armored Assault*).

*Design:* Tony Van Liew, Kevin Barrett. *Cover Artist:* Jim Burns. *Interior Artists:* Paul Yeh, Darrell Midgette, Ted Dinwiddie, Eric Bruns.

*Publisher:* Iron Crown Enterprises, P.O. Box 1605, Charlottesville VA 22902.

Inside this supplement you will find 30 vehicles of various kinds, 4 suits of Powered Armor, 6 Aircraft, and 10 Scenarios. Also included for your reading pleasure is a section on optional rules for the Armored Assault boardgame: coaxial gun mounts and skirting hills for better protection when on the move.

The vehicle and suit renderings are nicely detailed. You know what these items look like, no question about that. The presentation of the vehicle information is also good. Everything you need to know about these pieces of machinery is there. The set-ups are short but clear and victory conditions are easily understood. Each scenario also includes a diagram to show how to lay out the maps provided in the Armored Assault game. It's about time we got this supplement. Some people have a hard time making the vehicles needed for a good game and the ones provided get stale after a while. There is a nice mix of items here and a lot to choose from. The scenarios are easy to set up and there is some variety here as well. But there isn't enough. I want more -- MORE! I get tired of making these vehicles up and I could handle another supplement of this type. I think the next one ICE produces should include a couple of different map sections to add to the others from Armored Assault.

If you play Armored Assault you should buy this module. You can use this module even if you don't play the boardgame. If you play SpaceMaster, you have all you really need for rules, and the material here fits right in. If you play a different game, you might take a look at this module anyway because the vehicle drawings are good and the information provided is detailed enough to allow you to convert them to what you are using.

— Glen Allison

## Infantry Weapons of the World

104 pg book. \$12 (*Twilight: 2000*).

*Design:* Loren K. Wiseman, Frank Chadwick. *Cover Artist:* Steve Venters. *Interior Artists:* Kirk Wescom, Steve Bryant.

*Publisher:* Game Designers' Workshop, P.O. Box 1646, Bloomington IL 61702-1646.

**Infantry Weapons of the World** is a compendium of small arms from handguns to heavy machineguns. It is a handbook for *Twilight: 2000 2nd Edition*, but is usable with *Merc: 2000*, *Cadillacs and Dinosaurs*, and *Dark Conspiracy*, as these games use the *Twilight: 2000* rules. Although

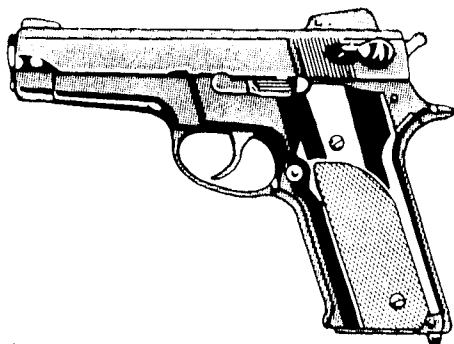

Infantry Weapons of the World art copr. 1991 GDW

some of these entries are included in *Twilight: 2000*, this book is still a good purchase, as it includes some changes in the weapon ratings to remove inconsistencies and add realism. A few new rules are also included, and the GDW staff even included their formula for rating weapons and ammo cartridges, in the event that you want to use a weapon or cartridge that is not included in the book. A price list and availability chart is included, with separate entries for *Twilight: 2000* and *Merc: 2000*.

This is a very useful book, and not only for GDW's games. As all weapons are illustrated, and very well at that, this book could be quite useful in any game using modern weapons. Because of the art quality, this book would even be of interest to nongaming weapons enthusiasts.

— James B. King

## U.S.S. Hampton

12 pg booklet, 6-11 x 17 deck plan sheets. \$11.95  
(*2300 AD*).

*Design:* J.R. Tenopir, C.W. Hess. *Cover Artist:* William H. Keith. *Interior Artists:* J.R. Tenopir, Stewart J. Chadwick, William H. Keith.

*Publisher:* Seeker Gaming Systems, P.O. Box 519, Mtn. Home ID 83647-0519.

**U.S.S. Hampton** is a set of deck plans in 25mm scale of an American Space Force 3700 ton destroyer escort. The package includes ship description, ship statistics, ship status sheet, class history and a listing of the vessels of the class and their current disposition. Ten paper figures in 25mm scale are also included, as well a short piece of fiction set aboard a Hampton class vessel.

These deck plans are nicely drawn and the details are easily discerned, but they would be easier to use if the plans were printed on a single sheet and inserted in the book instead of printed on six smaller sheets. The smaller schematic drawings of the vessel are also well done, but the paper figure drawings are rather poor. As there are no lead miniatures available for *2300 AD*, it's too bad these paper figures aren't of better quality.

The quality of the deck plan drawings make them desirable for play, but the package is a bit pricey at \$11.95. Still, if you're a dedicated *2300 AD* fan, the price probably won't bother you.

— James B. King

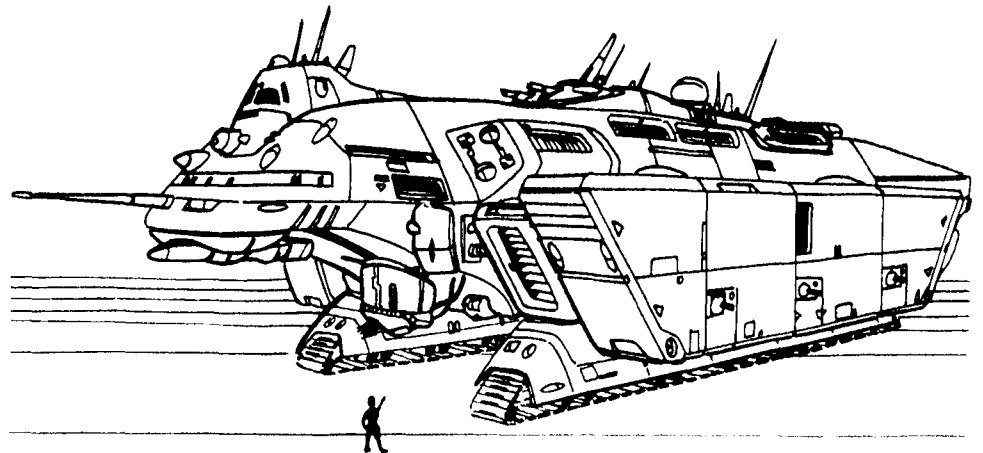

Armored Reserves art copr. 1990 Iron Crown Ent.

# MEGATRAVELLER™

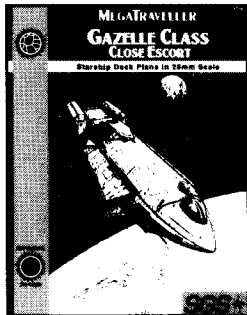
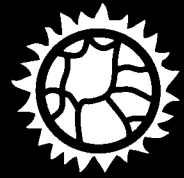

#1015 - \$11.95  
Gazelle-Close Escort

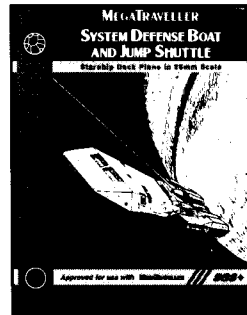

#1016 - \$11.95  
SDB & Jump Shuttle

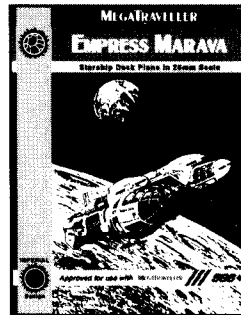

#1017 - \$11.95  
Empress Marava

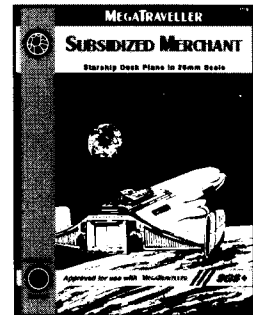

#1019 - \$11.95  
Subsidized Merchant

Add some *Excitement* to your Gaming Adventures with Detailed Starship Deck Plans in 25mm scale

STARSHIP DECK PLANS FOR **2300AD™** AVAILABLE IN 25MM SCALE

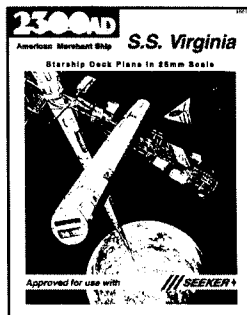

#3001 - \$11.95  
S.S. Virginia



#3002 - \$11.95  
U.S.S. Hampton

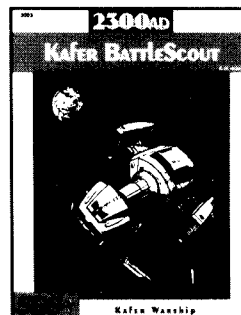

#3003 - June 91  
Kafer BattleScout



#3004 - Dec 91  
IDC Clipper Ship

## MEGATRAVELLER

Look for these New Releases coming soon!

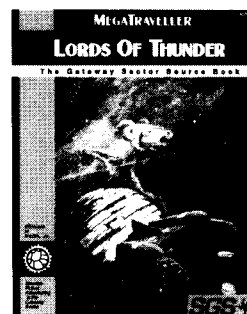

The Storm is Brewing  
in the  
Gateway Sector...

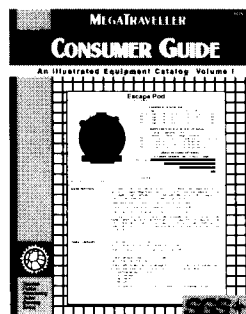

#1080 - \$11.95  
Consumer Guide  
Volume. I

**New!** Terrain Maps and Building Plans  
Detailed in 25mm scale from **SGS**

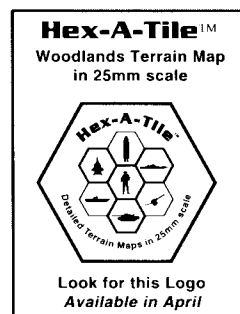

#151 - \$12.95  
Hex-A-Tile™: Woodlands

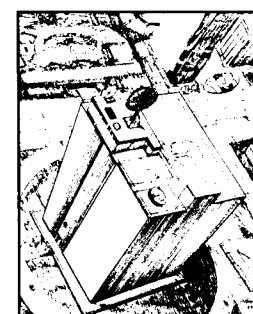

#101 - \$11.95  
Corporation Building  
from the Building Complex Series

MasterCard

VISA

Ask your local dealer for these products or order direct.  
P/H \$3.00 for U.S./Canada.  
Overseas \$6 U.S.  
Send for your **FREE** catalog today.

**SGS** ✦

SEEKER GAMING SYSTEMS  
P.O. Box 519  
Mtn. Home, ID. 83647-0519  
Voice/FAX Line (208) 587-2986

# It's A Gamer's Life

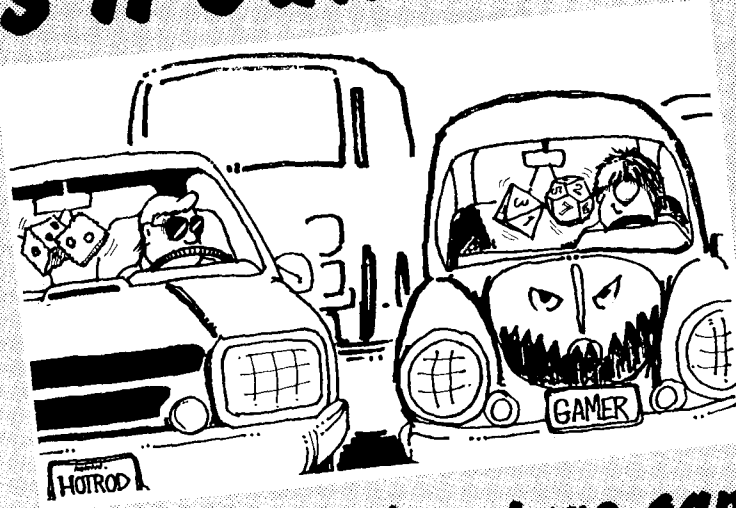

## Cartoons of adventure gaming

Compiled by James B. King

Facsimile of cover

Gamers know that journeying in the vast and varied realms of the adventure gaming hobby gets pretty serious. Well, gamers, this hilarious collection of cartoons is just what you need to tickle your funny bone and put some humor into your hobby. After all, it is a gamer's life, so read these 'toons and roll those dice with a smile!

Ask your dealer for this fine book or see page 19 of this magazine to order.

