

Issue
22

STAR FRONTIERSMAN

Magazine



Exploring the Frontier, One Incident at a Time

TABLE OF CONTENTS

ADVENTURE!	1
INCIDENT ON THE SINCA MARU	1
ALPHA SECTION:.....	2
BETA SECTION:.....	5
GAMMA SECTION:	15
DELTA SECTION:	15
EPSILON SECTION:.....	20
ZETA SECTION:	20
ETA SECTION:.....	21
SPACESHIPS	32
GOLD STAR CRUISE LINES	32
STARSHIP LEO	33
THE FRONTIERS OF DESIGN	45
EXPANDED KNIGHTHAWKS SHIP DESIGN	47
SOLAR SAILS IN STAR FRONTIERS	54
SPACE STATIONS: ISLANDS IN THE SKY	55
FRONTIER FICTION	59
HUNGER OF THE SHADOW	59
CHARACTER RACES	74
BELPHANS	74
BACKGROUND INFORMATION	78
FOOD ON THE FRONTIER.....	78
SUBJECT: RELIGION, SKILLS, HOMEWORLDS, ETC.	80
CLASSIFIEDS	82

ON THE COVER:

“Snow Vigil”, original Star Frontiers artwork by J. A. Davis

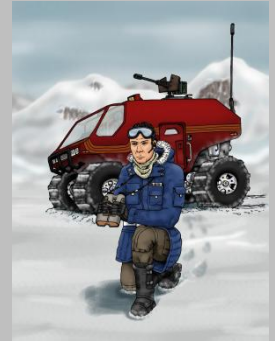

OTHER ART CREDITS:

» Artist Credit on images

FOREWORD

Another issue of the Star Frontiersman has come. I hope you have enjoyed the timing of the last few issues.

Enjoy J. A. Davis’ artwork on the cover and throughout the issue.

We have another adventure by Rollo (a.k.a. Ben Gorman). I just hope you don’t get infected.

A good spaceship addition to the commerce of the Frontier as well as another remastered Dragon article.

From Eric Johnson, there is a sequel to his story in Star Frontiersman #17, “Bug Hunt”. It is “Hunger of the Shadow”. And you thought Bladen and Gruk’s adventure was over.

I was going through some old Star Frontiers websites and found some great stuff. Andy Campbell over at the Star Frontiers Underground on Yahoo gave me permission to print some of his old articles. So I have included a large part of that in this issue.

I would like to thank the community of Frontier men and women who read this magazine. Without all of the interest and submissions, this magazine would not have gotten this far.

Raise your dice hand high!
William “Karxan” Douglass
Wdouglass1970@gmail.com

ADVENTURE!

By Ben Gorman

Incident on the Sinca Maru

Introduction:

This scenario outline is designed as a vehicle to introduce a dangerous new enemy to the frontier: The revenants. This scenario could be a one-time encounter or just the beginning of a long involvement depending upon the wishes of the GM.

It will be left up to the GM to determine exactly how this organism comes into contact with the crew of the Sinca Maru. Perhaps the organism lay dormant, encased in rock on one of the asteroids and was subsequently freed once the digger shuttle exhumed the colony. If broken apart during mining, the shuttle operator could easily have contacted some of the creatures floating about in billowing clouds of dust

particulates during standard operations. Or, the same could be said of operators aboard the Sinca Maru during standard ore-crushing operations. If the GM wishes to involve a nefarious race like the sathar, then perhaps the sathar were able to seed the asteroid with a small canister of micro-revenants after observing the Sinca Maru at work

If the former explanation is employed by the GM, then perhaps the PCs would be able to deduce such at some point during play. If the latter explanation is employed by the GM then perhaps the PCs might find some mangled metal canister somewhere in the ore processing lab aboard the Sinca Maru with some hint about its sathar origins.

Art by J. A. Davis

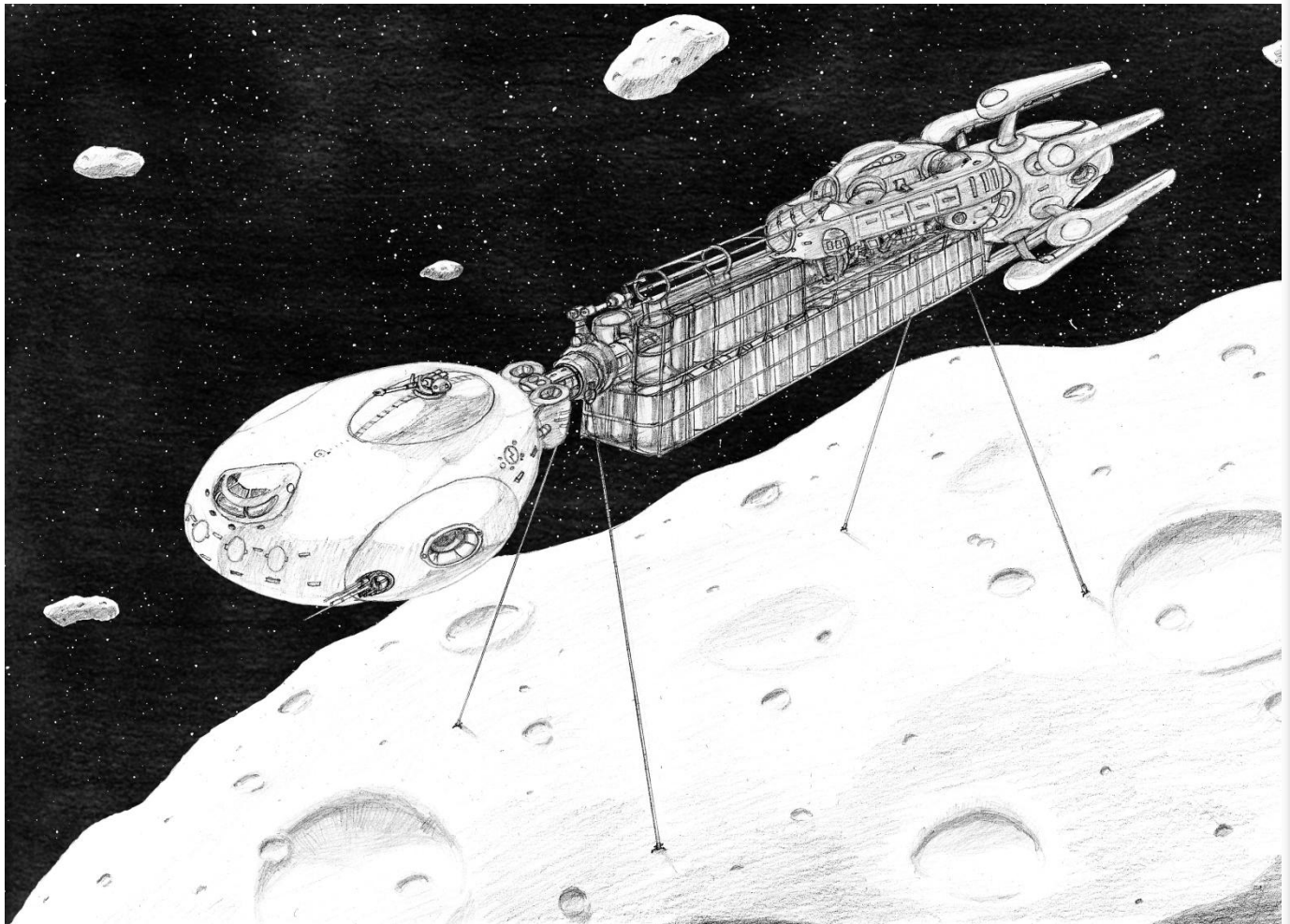

This adventure can easily be incorporated into any existing campaign or used as a stand-alone adventure, whichever the GM wishes. Unless otherwise noted, this adventure was created with Star Frontiers Alpha Dawn Remastered in mind (which can be found at <http://www.starfrontiersman.com/>).

Any rule-related questions concerning this adventure can be answered by consulting the aforementioned work.

“Incident on the Sinca Maru” is intended as a routine or medium difficulty Star Frontiers Alpha Dawn adventure for 4-6 players. Some technical and medical skill sets would be very beneficial as this scenario places the PCs directly in danger while encountering an extreme biological hazard in an enclosed space. Of course a good mixture of military skills would certainly be beneficial as there are certain physical conflicts involved in this adventure as well.

Alpha Section:

Abbreviations:

ADF: Acceleration/Deceleration Factor

ATT: Attack score

CDC: Cassidine Development Corporation

CDCEV: Cassidine Development Corporation Escort Vessel

CDCFH: Cassidine Development Corporation Freight Hauler

CDCMV: Cassidine Development Corporation Mining Vessel

DCR: Damage Control Rating

DEX: Dexterity

EXP: Experience Points

GM: Game Master

HP: Hull Points

HS: Hull Size

IM: Initiative Modifier

INT: Intuition

LB: Laser Battery

LDR: Leadership

LOG: Logic

MR: Maneuver Rating

MS: Masking Screen

NPC(s): Non-player Character(s)

PC(s): The Player's Character(s)

PER: Personality

RS: Reaction Speed

STA: Stamina

STR: Strength

Alpha Subsection 1:

Background Information; mining in space:

There are various methods of ore extraction in space. This body of work will describe one such method and the ship that carries out that style of mining.

The Sinca Maru is a large mining vessel owned by the CDC currently conducting mining operations in the Neela asteroid field in the Destruere system. The ship is outfitted with an ore processing lab and digger shuttle. It has a couple of unique features:

1. It sports grapples which are used to grab an asteroid and reel it in. Robotically controlled gantry-like arms then grab the rock and ram buffers extend from the ship to hold the rock in place.

2. The dust-like tailings from refining are directed out ejection ports that run through the aft section of the hull and ejected directly out the back of the ship thus keeping the debris from fouling the engines, engine struts or weapon batteries. The tailings can be siphoned off at engineering as a substitute fuel for the ion engines. Similarly, any asteroidal ice is melted during the process and that water is collected and used in the refining process.

The normal flight profile for this ship is with a number of ore hopper/cargo modules locked in the gantry-like arms. When a suitable asteroid is found they're remounted on the dorsal and sides of the ore processing lab where they will fill directly. For the return trip they will be returned to the embrace of the gantry arms unless they are simply jettisoned and picked up by a freighter tasked for that job.

Once a mining target is identified, the digger shuttle is sent to work. It is a specialized shuttle designed to scoop up quantities of ore and return that ore to the processing lab (See Zeta Section; Sinca Maru Processing Lab). The ore is then deposited by the digger shuttle into the Raw Ore Hopper where it is sorted by a combination of computer imaging and electromagnets. Ore comprised of various metals are sent to Crushers 1 and 2 and ores containing gem stones are diverted to Crusher 3. The crushers are nothing more than huge, chambered federanium drums that spin. The ore is fed into the drums which also contain hundreds of 10 pound federanium balls. These balls quickly reduce the ore to a fine, silt-like

material which is then sent to the settling tank for further processing.

With ore containing gemstones, the crusher does not contain federanium balls. Instead, the ore pulverizes itself to a much lesser extent – coming out of the process in much smaller chunks. This debris is then meticulously scanned by computers and any gemstones are sifted out by robots. The remaining ore is then returned to the Raw Ore Hopper and mixed back into the flow for crushers 1 and 2.

Once in the settling tank, the silt-like ore is saturated with water and automatically separated as heavier materials sink to the bottom and are siphoned off to the Shaker Tables. The lighter material meanwhile is siphoned off and diverted to the Waste Slurry plumbing. This waste slurry is then separated; the water returning to the system to be used again and the remaining silty material dried to a fine dust in the kiln. This dust is then ejected into space by way of the Tailing Ejection Ports at the back of the ship.

Meanwhile, the metal-rich ore that had been diverted to the shaker tables is further separated by the vibrating action of the tables. The heaviest material forms a band along the right side of the table. Adjacent to it is the next heaviest material and so on. In this way this type of processing lab is capable of extracting multiple lines of metal from single types of ore simultaneously.

Once separated on the Shaker Tables, the metal ore is then sent to Water Reclamation where the water is separated from the ore and reclaimed. The metal dust is then dried, crated and moved to a waiting cargo container.

If conducting mining operations alone, the ship will return to port once all of its cargo containers are full. More commonly however, such mining vessels work in conjunction with freighters. Once a cargo container is full, it is jettisoned and picked up by a waiting freighter which then drops off its empty container(s) for filling.

These ships require large amounts of water in order to extract the minerals they are after. In the maps listed in Zeta Section there have been two deck omissions because those decks are nothing more than huge open spaces that are filled with water for use by the Processing Lab and there was no need to map them. The holding tanks equal 9,000m³ (each) which equals

8.5 million liters (2.25 million gallons) of water (each). With these water reserves, the ability to reclaim the majority of what water is used and the ability to harvest water from mined ice, this type of ship can stay out for very long periods of time without needing to restock their water supplies.

Alpha Subsection 2:

Ships:

CDCMV Sinca Maru	
HS	20
HP	100
ADF	01
MR	02
DCR	80
Crew Size	50
Ship Dimensions	
Length	600m
Diameter	100m
Hatches	08
Engines	08 (Ion; size; C)
Weapons	LB x2, Grapples
Defenses	None
Other Equipment	Lifeboat (x2), Escape Pods (x20), Orbital Processing Lab, Digger Shuttle, Workpod (x4), Radar, Energy Sensors, Hull Cameras, Skin Sensors, Intercom, Subspace Radio & Videocom Radio.
Life Support for 50 people (with backup LS for 50 people if both systems are employed at the same time then 100 people can be sustained).	
Note: The digger shuttle is depicted as a HS 2 shuttle.	
This ship is the standard CDC company design for large mining operations.	

CDCFH Gumbully	
HS	20
HP	100
ADF	02
MR	02
DCR	80
Crew Size	20
Ship Dimensions	
Length	600m
Diameter	100m
Hatches	08
Engines	08 (Atomic; size; C)
Weapons	LB (x2)
Defenses	None
Other Equipment	Lifeboat (x2), Escape Pods (x20), Workpod (x4), Radar, Energy Sensors, Hull Cameras, Skin Sensors, Intercom, Subspace Radio & Videocom Radio.
Life Support for 50 people (with backup LS for 50 people – if both systems are employed at the same time then 100 people can be sustained).	
Note: This ship is the standard CDC company design for large freight hauling operations.	

CDCEV Razor	
HS	04
HP	25
ADF	03
MR	03
DCR	45
Crew Size	6
Ship Dimensions	
Length	75m
Diameter	12m
Hatches	02
Engines	02 (Atomic; size; A)
Weapons	LBx2
Defenses	RH & MSx2
Other Equipment	Workpod (x1), Radar, Energy Sensors, Hull Cameras, Skin Sensors, Intercom, Subspace Radio & Videocom Radio.
Life Support for 12 people (with backup LS for 12 people if both systems are employed at the same time then 24 people can be sustained).	

Note: This ship is a special company design and functions as the CDC's standard escort ship for mining operations in unprotected space. Crew size is six, but in a pinch the ship can accommodate up to 24 people. Therefore, in the case of an emergency, this ship can act as a rescue craft for the ship it has been assigned to escort.

Also, this ship sports two size A atomic engines (a HS 4 ship usually uses one size A engine). This allows for good acceleration and maneuverability compared to most other civilian ships.

Alpha Subsection 3:

Mission of the Sinca Maru:

The CDCMV Sinca Maru is currently conducting operations in the immense Neela asteroid field (named after the yazirian stellar geologist that discovered it while prospecting for the CDC) in the uninhabitable system in sector C (x-axis), 7 (y-axis) on the Star Frontiers 3.01 Map Grid (located at: [http://www.starfrontiersman.com/downloads/starfrontiersman In the Sheets & Stuff category under the heading July 04, 2007](http://www.starfrontiersman.com/downloads/starfrontiersman%20In%20the%20Sheets%20&%20Stuff%20category%20under%20the%20heading%20July%2004,%202007)), called Destruere (a K3 star: Chart in Zebulon's Guide To Frontier Space Remastered p.97).

The asteroid field was formed millions of years previous when two of the three planetary bodies in the system collided. The remaining planetary body (unnamed) is very small and is close to the system's star (roughly equivalent to mercury and situated between the star and the asteroid field). The field's debris has since scattered throughout the system to create an immense zone of rocky, metal-rich asteroids (two planets worth!) ranging in size from dust particles to a dwarf planet (800+ km diameter). Aside from the dwarf planet, there are also a few dozen large asteroids in the field about 300 km in diameter or a bit smaller.

Since the collision of the two larger planets in the system, the debris has become stabilized by the tidal influences of the K3 star. The asteroid field is a rich area for mining and is why the CDC has moved in and set up mining operations. Much of the ore being mined from this field in large quantity includes such metals as; gold, platinum, molybdenum, osmium, iron, nickel, titanium and palladium.

Currently the CDC has permanently stationed the Sinca Maru and its escort; the CDCEV Razor, in this system where the ship works continuously conducting its mining operations. Freighters routinely visit the Sinca Maru where they deliver supplies, replacement parts (if needed), and large cargo containers. As well, the visiting freighters rotate the crews of the Sinca Maru and the Razor periodically while also picking up the cargo containers filled by the Sinca Maru and hauling them back for further processing before sale.

In this way the Sinca Maru can remain on site working uninterrupted for extended periods of time, breaking only for major repairs or to move to a new asteroid to mine. The freighters are dispatched from Triad on a regular basis.

This is a new operation (only about a year old) and the CDC has plans to send more such mining 'teams' to the system in order to maximize their ore collection while at the same time minimizing the time requirements to 'play the field out'.

The last freighter (the CDCFH Gumbully) to visit the mining operation failed to return to port with its cargo of processed ore from the Sinca Maru and hasn't checked in. It is now 24hrs overdue. Consequently the manager of the CDC mining division located on Triad in the Cassidine system (which is, of course, also the location of the headquarters of the company) attempted to reach the Sinca Maru, the Razor and the Gumbully via subspace radio and was met with static.

Fearing possible pirate involvement, the CDC has suspended all further transport operations to the Destruere system until further notice. Meanwhile, they have prepared a small ship to send to the asteroid field to investigate. The PCs will be given schematics of all three ships in case they need to board any of them.

It is up to the GM and/or PCs to determine whether the players become involved because they are CDC security personnel or hired mercenaries. Similarly, it is up to the GM and/or PCs to determine whether the PCs will be using their own ship for this investigation or one provided by the CDC. The only stipulation is that the CDC suspects pirate involvement so the ship should be battle capable and the PCs should be expecting a fight.

If the CDC is supplying the ship, it is suggested that a civilian-equipped ship similar to an assault scout be provided at the GM's discretion.

The mission that the PCs are tasked with is to determine what happened to the mining team, render any assistance if possible, rescue any survivors if applicable and recover and/or secure any ships owned by the CDC.

From this point forward, any indented text can be imparted to the PCs.

Beta Section:

The Adventure Begins!

The ship exits the void and begins its deceleration into the Destruere system. Destruere is a K class star and its glow blankets the system with a warm, orange light.

All attempts to contact the Sinca Maru, Razor or Gumbully are met with static.

The days pass as the ship continues its deceleration. Finally individual asteroids come into view as the ship nears the last known coordinates of the Sinca Maru. The crew prepares for possible pirate interference and is surprised that the only ships on the scopes are pinging back the transponder codes for the CDCMV Sinca Maru, the CDCEV Razor and the CDCFH Gumbully.

There are no other ships anywhere in the solar system. The PCs may suspect that there are hidden ships somewhere in the area and the GM is, of course, free to play that out however they like. In reality the only ships in the entire solar system are the Sinca Maru, the Razor, the Gumbully and the PC's own ship.

Once the PCs come to within 100,000km (10 hexes) of the Sinca Maru and provided appropriate skill checks have been successfully made, they will find that the radio transmissions seem to be being disrupted intentionally – via a white noise broadcaster. The Sinca Maru seems to be the point of origin.

The Razor is about 30,000km (3 hexes) from the Sinca Maru and only a few hundred (800 +/-) meters from the Gumbully. The ship is nothing more than a debris field that contains the pinging 'black box' of the Razor.

Though there are some large pieces of wreckage within the field, there is nothing left that is capable of sustaining life support.

The GM is encouraged to allow the PCs to recover the Razor's 'black box' if they wish, though it is far too damaged to access without specialized equipment that they do not currently have. The only safe method to do so, since the box is surrounded by ship debris, is to use a workpod. However, a daring PC (or two) could conceivably don a spacesuit(s) and conduct a spacewalk to recover the 'black box'. Lots of sharp metal bits floating around out there could make for an interesting stroll though.

The demise of the Razor came as a result of the atomic engines of the Gumbully exploding nearby. The 'black box', once deciphered back at corporate headquarters, will have a record of the Razor docking with the Sinca Maru and the crew disembarking and heading over to assist with a medical emergency. Some of the crew later returned. Subsequent log entries detail a fast-spreading illness that apparently rendered the crew inactive. The data recorder will also have a record of the Razor's destruction as a result of a close proximity atomic event.

The Gumbully is about 30,000km (3 hexes) from the Sinca Maru and only a few hundred (800 +/-) meters from the Razor. The ship has broken into two pieces and is surrounded by debris from the vessel. None of the ship's engines are within the debris field.

The transponder ping that the PCs are receiving from the Gumbully is coming from the ship's 'black box'. Again, the GM is encouraged to allow the PCs to recover the Gumbully's 'black box' if they wish. However, the only safe method to do so, since the device is surrounded by ship debris, is to use a workpod.

Another point that should be mentioned is that none of the Gumbully's engines are to be found in the wreckage. The reason is because they were all jettisoned prior to them exploding. This is an important clue because it illustrates that the engines were either set to self-destruct but were later jettisoned or there was some sort of catastrophic engine failure and the crew jettisoned the engines in an attempt to save the ship.

If the PCs are able to recover the Gumbully's 'Black Box' they will find it intact and easily accessible by

rigging an interface between the recorder and a computer.

The data will show the following:

1) When the Gumbully arrived in the system, the crew found the Razor apparently unmanned and the Sinca Maru was similarly unresponsive.

2) The crew of the Gumbully boarded the Sinca Maru in an attempt to ascertain what had happened. Thirty seconds later, the Gumbully's instruments recorded a radio anomaly originating from the Sinca Maru that disrupted radio transmissions. This anomaly was not addressed by the crew of the Gumbully.

3) The crew of the Gumbully encountered a medical emergency aboard the Sinca Maru after finding two unconscious Razor crew members lying in the engineering section of the ship. These unconscious Razor crew members were brought aboard the Gumbully by two crew members of the Gumbully for medical evaluation and treatment. The rest of the crew of the Gumbully remained aboard the Sinca Maru at that time.

4) 1 hour and 17 minutes after being boarded by the two Gumbully crew members with their unconscious Razor personnel the ship's atomic engines began to overload.

5) 3 hours and 9 minutes after having disembarked, the rest of the crew of the Gumbully returned to the Gumbully and found that the unconscious personnel of the Razor and the two crew members of the Gumbully sent back with them were not found in the medical bay. The two crew members of the Gumbully were unable to be raised on their chronocomms.

6) 3 hours and 14 minutes after having disembarked, an unsuccessful attempt was made to restore the Gumbully's engines to standard operating parameters.

7) 3 hours and 23 minutes after having disembarked, the Gumbully's black box records a close-range nuclear event that fatally damaged the Gumbully.

From an external vantage, the Sinca Maru appears to be in perfect shape, though one of the external hatches (the mid-ship ventral hatch #4) is open; indicating that someone opened this hatch at some point and failed to secure it for some reason and the digger shuttle is drifting, apparently unmanned nearby. The ship does not appear to be conducting

mining operations however as there are no tailings being vented out into space.

Noting that there are no tailings being vented into space is the most obvious sign that the Sinca Maru is inactive. If the PCs search any of the nearby asteroids they will find ample evidence of past mining activity on the largest of the asteroids closest to the Sinca Maru.

The open external airlock hatch is a clue that there is some danger present inside the Sinca Maru. A number of crew members from the Gumbully failed to secure the hatch in their haste to exit the ship.

Beta Subsection 1:

Into the Abyss:

At this point the GM should be aware that the revenants aboard the Sinca Maru are only a few hours away from being able and ready to pilot the Sinca Maru toward civilized space. It has taken them time to assimilate enough of the officers to have the necessary skills to navigate and pilot the ship. At the point that the PCs gain access to the ship the

revenants will be making preparations to leave the system on their way to whatever location the GM deems appropriate. Likely a closed system, with a large population.

For this writing, it will be assumed that the PCs will be entering the ship via the open hatch previously described. However, should the PCs enter via a different hatch the below description is still applicable. In the case that the PCs choose a closed hatch, the GM will need to sort out how they will bypass security in order to open the hatch from the outside without the access codes.

Any equipment carried by revenants is equipment that was taken from the Sinca Maru weapons locker and the subsequent boarding parties from the Razor and the Gumbully.

The number of revenants detailed below is a combination of successfully assimilated crew members from the Sinca Maru, the Razor and the Gumbully.

Into the Airlock by J. A. Davis

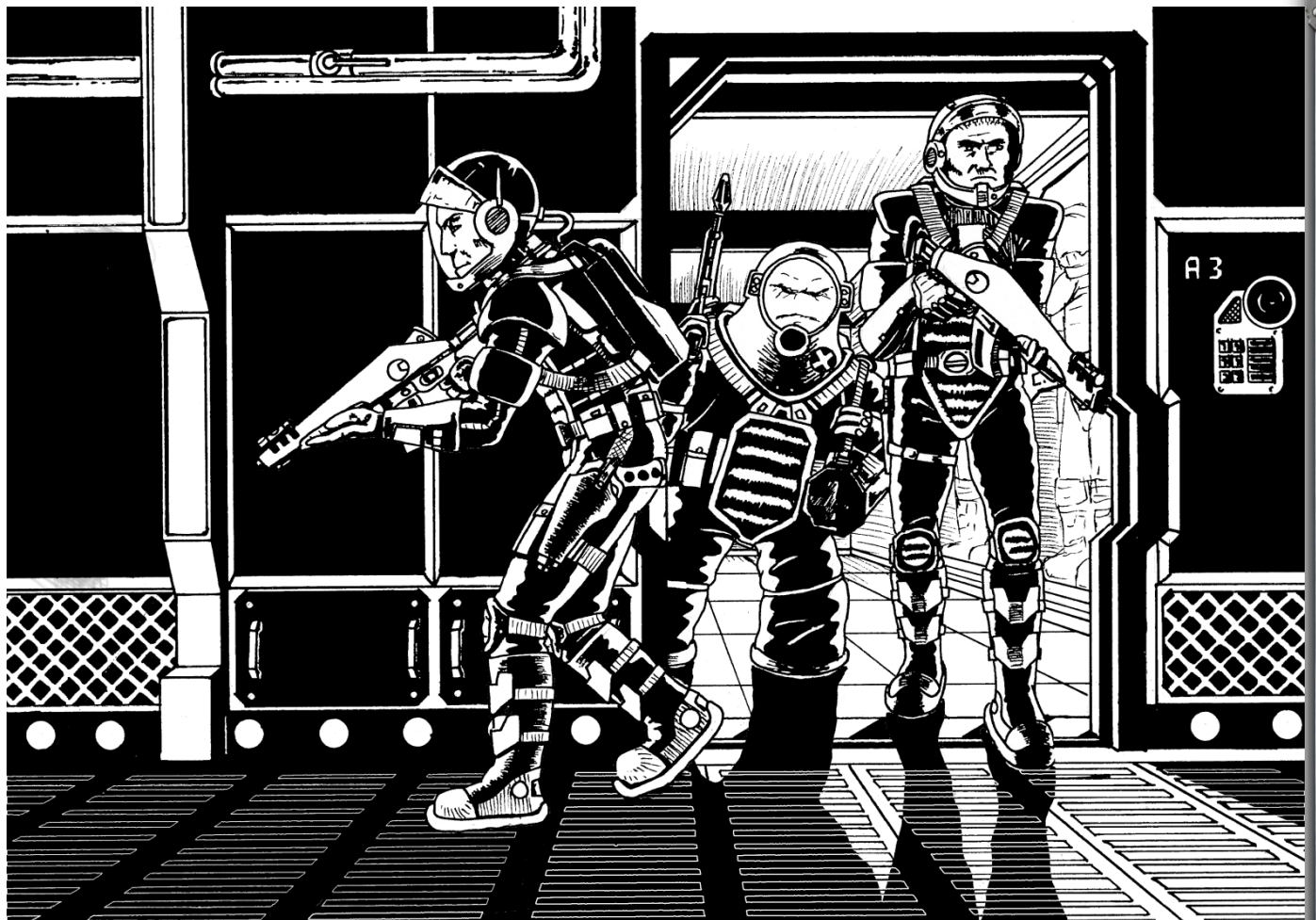

As the boarding party approaches the open hatch they can clearly see that the lighting inside the airlock is persistently flickering.

The airlock begins its pressurization sequence after the external hatch is secured. The boarders wait patiently for several moments as the cycle completes. The solid red light over the internal door blinks out followed immediately by a solid green light. The automatic door mechanism begins to rotate to the left and the door opens with a solid '**CLUNK**'! The crew can feel it reverberating through the door frame more than they can hear it.

Immediately the boarding party is assaulted by loud and persistent static coming from the intercom system. And as well, it would seem that the lighting situation extends to the rest of the ship, or at least to their immediate vicinity.

Now that the airlock is pressurized, beads of moisture can clearly be seen forming on the airlock walls and even more obviously, upon the visors of the boarding party's spacesuit helmets. This suggests that the temperature and humidity levels are extraordinarily high throughout the ship.

If the intercom next to the airlock door is turned off manually the static will stop from that one source. The problem is that the static seems to be being piped over all intercoms ship-wide. So until the source is found, the PCs will have to suffer through the headache-inducing and hearing-impairing noise. Similarly, the ship has suffered a power surge of some sort and until that has been repaired the lighting throughout the ship will be spotty at best. Some lights will be flickering in a strobe-like fashion and other sections will have been blown out completely, leaving areas of the ship completely dark.

The radio static can be shut off at the bridge – this will be common knowledge to any PC with any starship experience.

The electrical problem can be addressed in engineering – this will be common knowledge to any PC with any engineering or starship experience.

The atmospheric situation can be addressed in main or emergency life support – this will be common knowledge to any PC with any starship experience.

Currently the temperature is +40C (+105F) and the air is extremely humid.

The following assumes that the PCs at least take off their spacesuit helmets. The GM should make adjustments as needed if that is not the case. It should also be noted that if the PCs never remove their spacesuits and so long as those suits never get breached in combat, they will not be exposed to the revenants unless they get exposed while removing their spacesuits at the end of the scenario once they return to their own ship.

The acrid smell of ozone permeates the air as the occasional shower of sparks issues forth from the track lighting here and there. Shortly after arriving in the spacesuit locker room just outside the airlock a blood-smearred human hand print can clearly be seen on the wall next to the exit door about a meter from the floor. The door stands partially open.

Beyond the exit door lays a long hallway that sparkles with intermittent cascades of sparks from the lights. The hallway is about thirty meters long, six meters wide and six meters tall. Recalling the schematics of the Sinca Maru, the party knows that there will be an elevator fifteen meters away which will grant them access both fore and aft of this point. Beyond that elevator is another external hatch (#3) and a ladder that leads up to a pressure door which goes into the Processing Lab.

Beta Subsections 2-4 will focus on the exploration of the ship from this point (Mid-Ship Ventral Hatch #4). The GM will therefore be free to jump to whichever subsection is applicable depending upon which way the players choose to go. Unless otherwise stated, the static will be blaring over all speakers' ship wide. The GM should inform the PCs at every opportunity unless they have already rectified that situation.

If the GM decides to take the elevators out of commission for whatever reasons it should be noted that all elevator shafts have secondary ladder access that connects all decks of the ship for just such emergencies.

Beta Subsection 2:**Exploring Aft:**

As detailed in Gamma Section: Revenants; the high amount of moisture in the area denotes an infected hot zone. Anyone not adequately protected and following strict bio-hazard protocols at this point will likely become infected by a micro-revenant colony (if their clothing becomes saturated with moisture, the micro-revenants can come into contact with the skin for example). As well, the revenants are now aware of the presence of the PCs aboard the Sinca Maru. Since each deck is interconnected via conduits and air ducts, the high humidity in the ship allows ship-wide contact for the revenants. This also means that the entire ship is a biological hot zone except where otherwise noted.

Since the PCs can pick and choose which deck they wish to stop at or bypass, each deck will have its own heading so that the GM can jump to whichever deck the PCs choose to go to.

Beta Subsection 2A:**Processing Lab Escape Pods:**

The elevator stops smoothly. There is a pleasant 'pinging' sound and the door silently slides open, emptying the party into another humid hallway. The lighting is flickering, though thankfully there are no hissing sparks to contend with.

According to the ship's schematics, this hallway goes to elevators positioned at the port and starboard sides of the ship. Each elevator goes to the corresponding Escape Pod Launch Bays. The below information is applicable for either room.

Once in the Escape Pod Launch Bay it is immediately clear that something is amiss as all of the pressure doors are standing open and there is debris littering the floor. Upon closer inspection, the debris looks to be bits and pieces of some electrical component or components.

Careful inspection of the room reveals that there is no danger here, but it is obvious that the debris on the floor outside the launch bays are the remaining bits of the escape pod's launch consoles and that someone has deliberately smashed every launch console (in both launch bays). It is also readily apparent that each of the escape pods access hatch is open. Peering

inside, the smashed remains of the manual launch controls are easy to see.

It will be impossible to launch any of these escape pods in their current condition. It would take several hours and parts from Engineering to repair each one. The manual launch controls would have to be completely rebuilt.

Beta Subsection 2B:**Life Support and Emergency Bridge:**

When the elevator slides open the party is greeted by total darkness and a horrific stench.

It is assumed that the PCs have some sort of light source or dark vision capabilities. Regardless, it is literally pitch dark in here. No light sources other than those held by the PCs (if any) and this is an internal room with no portholes or any other way for light to make its way here.

Three doors can be seen about nine meters ahead. One to the left (2) and right (2) and one straight ahead (3-10). All three are currently closed and no sound can be heard over the mind-bending noise of the radio static.

The door to the left (2) has been partially broken down and there appears to be a dark fluid smear of some kind covering much of the left side of the door and some of the doorjamb.

If the PCs take the time to check and have the proper equipment, the GM may allow them to determine that the stain is at least two pints worth of vrusk blood.

Investigating the room further, thirteen husk-like objects can be seen scattered around. Each one is roughly two meters in length and about a meter wide. They have all been split open and contain nothing but pools of blood-like liquid. The floor around each husk is slick with a viscous, mucus-like fluid and they exude an overpowering stench of decayed flesh.

Furthermore, the life support equipment in this room has been smashed to pieces. According to the schematics however, there should be another life support terminal in the room across the hall.

The door across the hall is standing open (2). Inside are seven husks in a similar state to those in the

adjacent room. The life support equipment in this room has also been smashed to bits. It would take an engineer a few days to rebuild it unless they had a replacement console that they could just wire in.

The last door to investigate leads to the Emergency Bridge (3-10). This door is closed.

If any PC attempts to hear anything through the door (taking into account the annoying speaker static), they may do so with a -30 modifier. If successful, they will be able to hear a soft, crackling and ripping sound.

Opening the door to the Emergency Bridge (3-10) reveals eleven husks and smashed consoles. As with the previous rooms, this one is in complete disarray; a horrific scene of rotting mounds of fleshy matter strewn haphazardly amongst the scattered remains of electrical components.

Any successful perception checks will reveal that there is one husk that has not split open and appears to be occupied. Also, propped against the smashed astrogation station is a victim (previously human) in the middle stages of husk creation. He is lightly covered in mucus-coated, flesh-like, venous matter from mid-chest down. Those portions of his skin which are visible appear to be partially decomposed. There is also one newly 'hatched' husk revenant (previously yazirian) lying on the floor beneath the pilot's chair. It will attack with its bare hands as soon as any PC gets close enough, otherwise it will continue to lie still and hidden.

These stats can be adjusted by the GM if they wish to increase or decrease the difficulty of the encounter.

Examples:

Weak revenant stats (with a core four host):	
STR/STA	35/35
DEX/RS	30/30
INT/LOG	45/45
PER/LDR	30/30
PS	+2
IM	2
Ranged	15 + 10 = 25
Melee	18 + 10 = 28
Skills:	
Ranged	1
Melee	1
GM's choice of 4 more skills all at level 1	

Average revenant stats (with a core four host):	
STR/STA	45/45
DEX/RS	40/40
INT/LOG	55/55
PER/LDR	40/40
PS	+3
IM	3
Ranged	23 + 20 = 43
Melee	20 + 20 = 40
Skills:	
Ranged	2
Melee	2
GM's choice of 6 more skills all at level 2	

If the occupied husk is opened by the PCs they will find a partially transformed revenant (previously human). Though it can struggle weakly (if the husk is disturbed it will squirm around), it is incapable of defending itself and can be easily dispatched.

Beta Subsection 2C:

Machine Shop and Robotics:

The party is greeted with the stench of decay as the door slides open to the short hallway beyond. The lights are flickering here but there aren't any sparks crackling from the fixtures at least. About a meter ahead are two doors, one to the left and one to the right. According to the ship's schematics, each door should lead into the shop.

Once inside the PCs will be able to see two empty husks in the shop. There are some tools scattered around on the floor as if a struggle had taken place here but otherwise, there is nothing else of note.

Beta Subsection 2D:

Engineering and Emergency Life Support:

There had been no transformations on this deck so there is no overpowering stink to meet the PCs. There is however, a contingent of revenants (ten of them +/-) here ready and waiting. They have set up a barricade in the hallway and are hiding behind it thus receiving a hard cover bonus (-20). Similarly the bright work lights (floor lamps) that they have set up are aimed directly at the elevator door so when it opens the PCs see only the intense glare of the lights. Around the periphery of that glare the hiding figures of the revenants can be

discerned but at an additional -10 modifier to combat. Any PCs wearing infrared goggles will be blinded until they remove their goggles.

Each revenant in this encounter has one laser pistol with two long e-clips and is wearing a civilian skein suit and an albedo screen with a power belt pack. They will begin attacking as soon as any PC comes into view at the elevator.

The GM is free to choose the revenant type (weak or average detailed in Beta Subsection 2B above) and number for this encounter in order to balance play for his party. It is suggested that no more than ten and no less than five revenants be used here.

If the barricade is being overrun the revenants will fall back into the engineering room (the one with the work benches and bathroom). They will do everything they can to kill the PCs or push them back. Since this is the only functioning life support interface it is a very important deck to them.

Revenant by J. A. Davis

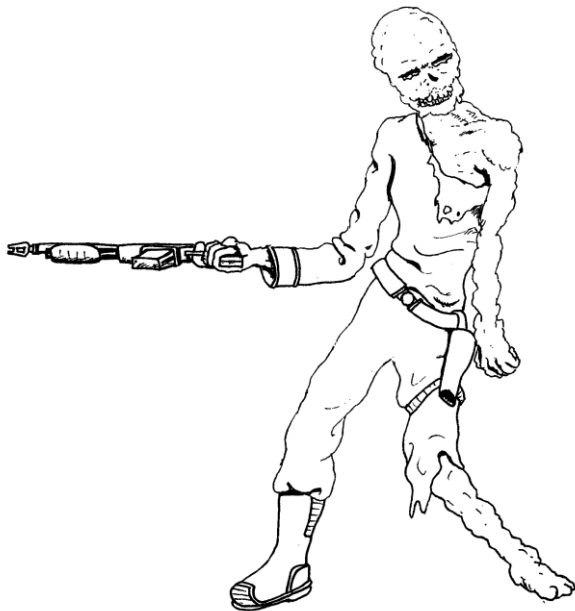

If the PCs are able to take the deck then they will be able to adjust the temperature and humidity levels of the Sinca Maru – thereby interrupting communications for the revenants. It will take about an hour for the atmosphere to stabilize once the system has been adjusted. They will also be able to repair the ship-wide lighting malfunction if they wish to take the time to do so. It is a matter of accessing

the engineering computer and rebooting the system then switching to the auxiliary power and resetting the power flow. All of which can be done at the engineering computer (station 5 on the map) and will take about fifteen minutes (five minutes per step).

Beta Subsection 2E:

Maintenance:

As the elevator door opens the party notes that all of the workpods have been disabled. Someone has deliberately bashed the controls of each workpod to pieces as well as the launch interfaces.

Until repaired, it will be impossible for the PCs to use any of the workpods. Nothing else has been disturbed on this deck.

Beta Subsection 3:

Exploring the Processing Lab:

There are four ways into the processing lab. Internal pressure doors located in the hallways connecting external ship hatches #3-4 and 5-6; one access point per hallway. The other two ways are both external access points at the raw ore hopper and the cargo hopper.

The two internal access hatches are locked and will need to be bypassed in order to enter. A successful skill roll for Open Locks will open these doors and allow access.

The two external access points are locked and will need to be bypassed in order to enter. A successful skill roll for Open Locks will open these doors and allow access.

The processing lab is huge, about 23 meters high, 38 meters wide and 160 meters long. It is a maze of pipes and machinery. Usually it is noisy to the point that workers must wear hearing protection in order to work inside. It is completely quiet now though. Not even the static from the speakers intrudes here.

The processing lab is a module attached to the main ship. It has power couplings that attach to the ship in order to power the structure. But it also has its own life support machinery; though only a basic configuration. It is designed this way to handle the

inordinate amount of dust that the processing lab's scrubbers have to filter in the atmosphere. The processing lab therefore, is cool and the humidity level is stable.

There are seven survivors hiding in the processing lab. None of them have been exposed to the revenants.

The GM is encouraged to play up the fact that these survivors will be terrified by the PCs breaking into their hideout because they have firsthand knowledge of the sickness and would likely assume that the PCs are either revenants or are infected (and in truth, the PCs likely are infected by now). They are completely unarmed except for lengths of pipe and some spanner wrenches, so they will hide as best they can. This can lead to an tense game of hide and seek which could potentially end in the PCs shooting and killing one or more of the survivors accidentally. Ultimately it is left to the GM to decide how to play this out.

If the GM wishes to provide the PCs some back story, now would be a perfect time to do so, though any contact with the PCs will be at a distance far enough that speaking loudly to each other would be the only way to effectively communicate as the survivors will be sure to keep a good distance from the PCs.

For the purposes of this writing (the GM's storyline may, of course, be different as outlined in the introduction above), the survivors will be able to explain that one of the digger shuttle operators became sick and was sent to the infirmary. Shortly thereafter the illness began to spread. The theory was that there was something in the dust that got him sick. For the first time the PCs will be informed (and/or have their suspicions confirmed) that the illness is highly contagious and extremely deadly. So far the mortality rate of those infected has been 100% as far as these survivors and the PCs know (remember, none of these survivors had been sick so to the best of their knowledge none of them have yet been exposed).

If the survivors are questioned, the PCs will learn that they are all from a maintenance crew working on the processing lab during scheduled maintenance downtime. They were all in the processing lab when things got really bad (the GM should feel free to expound upon this as they see fit; graphic detail, whatever fits into the GM's storyline). At the time a couple of their crew had headed down to the galley to eat and had encountered some revenants. They were able to radio back to their maintenance crew via

chronocom and tell them of the situation before they were overwhelmed. The seven survivors in the processing lab have been locked up in here ever since – about nine days. They've been living on some emergency rations they found in a storage locker and water from a fresh water holding tank. One of them had the idea that water from the various taps might be contaminated and so they have been drinking from that self-contained holding tank exclusively. Good thing to because water from the ship's storage systems is indeed contaminated.

Beta Subsection 3A:

Digger Shuttle:

If the PCs ever investigate the digger shuttle they will find that it is half-loaded with ore and that the hatch is open. The shuttle has no occupants – though if the GM allows it, two partially decomposed corpses can be seen drifting nearby. Seemingly in a delirious stupor, one of them appears to have exposed the cabin to space.

Beta Subsection 4:

Exploring Fore:

As detailed in Gamma Section: Revenants; the high amount of moisture in the area denotes an infected hot zone. Anyone not adequately protected and following strict bio-hazard protocols at this point will likely become infected by a micro-revenant colony (if their clothing becomes saturated with moisture, the micro-revenants can come into contact with the skin for example). As well, the revenants are now aware of the presence of the PCs aboard the Sinca Maru. Since each deck is interconnected via conduits and air ducts, the high humidity in the ship allows ship-wide contact for the revenants. This also means that the entire ship is a biological hot zone except where otherwise noted.

Since the PCs can pick and choose which deck they wish to stop at or bypass, each deck will have its own heading so that the GM can jump to whichever deck the PCs choose to go to.

Beta Subsection 4A:**Fire Control (either dorsal or ventral deck):**

The fire control rooms are both undisturbed and perfectly functional. Depending upon whether the PCs have repaired the atmospheric conditions and/or the lighting situation, the GM should continue with descriptions of high humidity and troublesome lighting as applicable.

Beta Subsection 4B:**Common Area:**

As Beta Subsection 4A above, depending upon what has or has not yet been repaired; the GM's description(s) should reflect those realities.

Regardless of which elevator the PCs exit into the common area they will have an immediate view of a 30 meter long hallway ending at a set of doors that lead into the male and female restrooms respectively.

The party is immediately assaulted by the stench of death when the elevator doors open into the common area of the Sinca Maru. They are similarly assailed by the loud shriek of a female yazirian about 30 meters down the hall by the restroom doors. At first glance it appears as though she has run out of the restroom at the moment the elevator doors opened. Unfortunately for her, she runs headlong into the waiting arms of a shambling, desiccated figure. The assailant plunges what appears to be a vibroknife into the female's abdomen and with a quick twist, yanks the blade to the side, drawing a deep wound that clearly eviscerates the yazirian in a spectacle of gore (almost cutting her in two from side to side!). A moment later another of the creatures steps out of the restroom that the yazirian had only just fled from.

If the PCs ever get around to inspecting the yazirian female they will discover that she was clearly infected and was certainly in the latter stages. If left alone her corpse will eventually become enveloped in a husk and transformed.

This is a large deck with many rooms and hiding places. If the GM chooses to have any other survivors on this deck they should be few in number (one or two more at most) and all of them will be in the later stages of infection without doubt. Meaning that, even if the PCs are not aware of it, they are beyond help

since they will not be able to receive hyperbaric oxygen therapy in a hospital setting before it is too late.

This deck contains a total of thirty empty husks and forty three revenants. They are scattered about the deck and the GM should feel free to describe where the PCs encounter them wherever they wish. Once the PCs step onto the floor plating of the deck though, the revenants will be aware of their exact location. The 43 revenants have a total of four laser pistols (with two long e-clips for each one), fourteen vibroknives (with one long e-clip for each one), four civilian skein suits and four albedo screens (with a backpack for each one) randomly scattered among the hoard. Generally speaking, no one revenant should have more than one of the above-listed items on this deck.

The GM should use the stats detailed in Beta Subsection 2B for the revenants on this deck.

If the PCs ever get around to exploring the infirmary they will find five dead corpses there that appear to have been thoroughly burned with a makeshift flame thrower. The PCs will also find numerous empty bottles of sodium hypochlorite strewn about the infirmary and the surgical theater. There is also some human male remains stretched out on the surgical table. It has obviously been autopsied. The room smells strongly of bleach.

If any of the PCs use their Access and Operate and Bypass Security skills on the medical computer in the infirmary they will be able to download vital medical information concerning this race (whatever the GM wishes to impart). This information would be invaluable to the medical profession back in civilized space.

Beta Subsection 4C:

Bridge: 10 revenants here

As Beta Subsection 4A above, depending upon what has or has not yet been repaired; the GM's description(s) should reflect those realities.

The bridge is occupied by eight strong revenants. These were mostly the officers of the three ships and represent the best specimens of the host pool that the revenants had access to. These revenants are expecting trouble and will begin attacking as soon as the elevator doors open.

Equipment common to all eight strong revenants:

- 1 laser pistol with 2 long e-clips
- 1 vibrokife with 1 long e-clip
- 1 doze grenade
- 1 tangler grenade
- 1 civilian skein suit
- 1 albedo screen with 1 belt pack

When the elevator door slides open and the bridge comes into view the PCs are immediately greeted by the sound of laser fire.

Strong revenant stats (with a core four host)

STR/STA	55/55
DEX/RS	50/50
INT/LOG	65/65
PER/LDR	50/50
PS	+3
IM	4
Ranged	25 + 30 = 55
Melee	28 + 30 = 58
Skills:	
Ranged	3
Melee	3
GM's choice of 8 more skills all at level 3	

Revenant Attack by A. J. Davis



Beta Subsection 5:**Wrapping Things Up:**

By this point in the scenario each member of the party is likely infected by the revenants. Thankfully, they have the Sinca Maru's medical logs and will be able to ascertain that a simple regimen of omnimycin, 4 per day for 12 days, will fix them right up (as detailed in Delta Section: Treatment). If the PCs don't have enough omnimycin in their own supplies the GM should consider allowing them to find enough aboard the Sinca Maru to allow them to survive the ordeal.

Gamma Section:**Experience Awards:**

This adventure can effectively be broken into two parts as far as experience is concerned. The outline of exp awards below shows the exp given to each party member.

First Part:

Exploring the ship and rescuing the seven survivors in the processing lab.

Maximum EXP award:

10 points should be awarded for groups that are able to complete all of their mission objectives and suffer no PC deaths during this part of the adventure.

Average EXP award:

08 points should be awarded for groups that are able to complete most of their mission objectives and suffer 25% or less casualties during this part of the adventure.

Minimum EXP award:

05 points should be awarded for groups that are unable to complete most of their mission objectives and suffer more than 25% casualties during this part of the adventure.

Second Part:

Recovering the black boxes of the Razor and the Gumbully and recovering the medical data from the infirmary.

Maximum EXP award:

10 points should be awarded for groups that are able to collect both black boxes and the medical data and suffer no PC deaths during this part of the adventure.

Average EXP award:

08 points should be awarded for groups that are able to collect at least two of the three items and suffer 25% or less casualties during this part of the adventure.

Minimum EXP award:

05 points should be awarded for groups that are only able to collect less than two of the items and suffer more than 25% casualties during this part of the adventure.

Delta Section:**Revenants (NPC race):**

Micro-revenants are microscopic organisms akin to flesh eating bacteria. In game terms this means that combat with a revenant in this form is restricted to medical treatments and does not involve the Star Frontiers: Alpha Dawn combat rules. This situation changes as the revenant's life cycle progresses however, and is detailed below.

In their microscopic form, these creatures can be harmed by certain antibiotic applications (omnimycin) and some chemical applications (sodium hypochlorite and other such caustics). Open flame and high heat (boiling or hotter) will also destroy a revenant colony. They can however, survive a vast array of destructive forces. This is accomplished by simply going dormant. They can be frozen solid and, once rewarmed, become active again. They can be encased in mud with the lump of mud eventually petrifying, but once cracked open and exposed to an atmosphere, can again become active (thereby living for millennia). They can even survive the void of space (so long as such exposure does not cause them to become completely desiccated in the process) by simply becoming dormant until such time as conditions permit their return to activity.

In order to remain active all they need is a degree of warmth (any temperature above freezing and below boiling), a liquid medium in which to move about (preferably water or something close – like blood) and some small amount of oxygen (it doesn't take a whole lot at all, about 100 parts per million will allow them

to function), and a food source. The absence of any one (or all) of these requirements does not mean that the revenant will perish, it is more likely that it would only cause them to go dormant until such a time as the conditions for activity are met.

They eat any animal protein they encounter in order to sustain life and do not care whether that flesh comes from an unintelligent beast or a thinking being. They infect a victim through direct physical contact (against the bare skin of the victim) and do not require a wound to gain entrance to the host's body; simple contact will suffice.

Revenants communicate to each other through touch. A revenant's 'body' is covered with tiny hair-like growths (cilia) that are in constant motion, thereby propelling the tiny creature through the liquid environment in which it lives. Aside from allowing movement, these cilia also transmit thoughts from one revenant to another instantaneously through simple contact. This enables a revenant 'colony' inside a host creature access to a collective mind, allowing for instant communication between all micro-revenants that make up the colony.

A colony of revenants may start out as only a few (a dozen or so) individual organisms. Once they are able to infect a host, they quickly begin to multiply. They do so by attacking and killing an individual living cell, and then consuming it. After consumption, the micro-revenant is able to divide itself through the process of binary fission. Consuming another dead cell allows the organism to divide again, and so on. In this way the micro-revenant is essentially replacing the host's cells with other micro-revenants; or, in other words, revenant procreation. This process proceeds at an exponential rate until the 'death' of the host creature/being at which point, the revenant will metamorphose into a different form (detailed below).

One very dangerous aspect of a micro-revenant is that, once they have infected and taken over a living host, they are able to assimilate that host's knowledge, eventually assimilating the depth of knowledge of an entire race if they are able to assimilate enough of that race's population to account for all of its collective knowledge. One colony (micro or macro) can pass on its assimilated knowledge to any other colony simply by touch.

Over the course of time this ability has allowed these organisms to achieve an awareness of self and

intelligence. Though their biology (in their microscopic form) prevents them from utilizing their intelligence to create such things as tools or technology, it in no way hampers their ability to force their hosts to do so for them.

Symptoms of micro-revenant Infection (each stage is cumulative with the stages that follow it): Assuming the victim is healthy. Ill or otherwise compromised victims would deteriorate at a much faster rate (it is left to the GM to determine, but it seems plausible to reduce the time it takes for the transmutation process by half).

On average, a host being (about the same mass as a human) may expect to begin to experience flu-like symptoms (nausea, vomiting, fever, chills, diarrhea) accompanied by the site of contact being extremely painful (-10% to all actions), swollen, an off 'greenish' color that fluoresces under a black light and is warm to the touch (of course, touching the infected area would pass the infection to the individual that just touched it unless bio-hazard protocols are being strictly followed [wearing protective clothing, etc.]) within 24-36hrs after exposure (stage 1).

8-12hrs later the area of first contamination will begin to exhibit signs of necrosis (stage 2). For each hour thereafter, the necrosis will continue to advance about 2.54cm (1in) in every direction radiating away from the point of first contact. The victim will begin to lose the ability to control those parts of their body that have become necrotized by the revenant infection. For the sake of simplicity, if the revenant infection covers 5% of the victim, then the victim loses control of that 5% of their body that had been infected and subsequently necrotized.

Once 25% of the victim's body (about 60hrs for an adult human) has been necrotized the revenants will have made their way throughout the entire body of the victim and will be able to exert full control over the functions of the body (stage 3). During this time period the revenant colony will be in full control of the host's body. The host will still be conscious (though oddly, no longer feeling any pain or other discomfort) and able to think, though it will seem more like a dream or rather, nightmare state to the victim. Meanwhile, the revenant will be able to move about (precluding the possibility that the host has sustained damage and cannot move about, etc) with the host's body and accomplish those tasks/skills that the host was capable of doing previously (including speech!).

The revenant colony will also be completely aware of the host's family and loved ones and if they happen to be within reach, may consider them easy targets for colonization.

Once 50% of the body (about 60 more hours for an adult human) has been necrotized the body will cease to function (die) due to septic shock and organ failure (stage 4).

After the host body dies the corpse will exude a sickly, mucous-like substance that will form over the entire corpse and harden like a cocoon. 72hrs of inactivity later the revenant will emerge in its new form (see below). Any technological implants that the victim had will have been purged from the body and will remain in the biological material left in the cocoon. Such devices are unusable by the revenants.

The whole process takes on average, about 10 days for an adult human.

If any infected flesh is excised (in any manner that does not completely destroy it) it will continue to carry the revenants infecting at the time of excision. Meaning, unless excised infected flesh is completely destroyed (flame works particularly well!), the flesh in question will remain capable of infecting any other flesh it comes in contact with. If the piece of flesh in question happens to have an ambulatory ability (a hand for example), it is possible for the diminished revenant colony residing in that hand (in this example, it could also be a partial torso with a functioning arm still attached to it, etc.) to move itself to a different location in order to avoid eradication. It would then be free to restart the cycle all over again if at all possible. Once dead, the host is dead. It's knowledge lives on in the revenant colony but absolutely nothing else of the original host survives.

Treatment:

Stage 1: Treatment at stage 1 consists of massive doses of omnimycin (4 per day for 12 days), during which time the victim will be feeble and sickly, unable to lift themselves out of bed and wracked with all the symptoms of stage 1 infection during the first 10 of the 12 days of treatment. If any dose is missed during the course of the 12 day regimen, then another day (and 4 more doses of omnimycin) will need to be added to the recovery period. If a full day's worth of inoculations are missed (at any point during the

treatment) then the entire regimen would have to be started over.

Stage 2: Treatment at stage 2 consists of the excising of the necrotic tissue as well as the (seemingly) healthy tissue at least 2.54cm (1in) in every direction from the area of necrotic tissue; in addition to the treatment detailed in stage 1 above.

Stage 3: Treatment at stage 3 consists of the treatments detailed in stages 1 and 2 as well as the continual application of hyperbaric oxygen therapy in a hospital setting. Even then there is a 50% mortality rate. At this stage, if this treatment is not available then the mortality rate jumps to 100%.

Stage 4: Once the revenant infection has reached this level there is no further treatment available.

Macro-revenants are much different than the micro-revenants.

Once the metamorphosis has been completed, the revenant emerges as a grotesque semblance of the creature that had previously been consumed. The revenants utilize the endoskeletal structure of other beings in order to fashion their colony around it and use it as a vehicle to give them access to mobility on a larger scale. Think of it as their way of 'constructing' a 'space ship' through a biological process; bioengineering after a fashion. This allows them the freedom to break the bonds of their microscopic nature and exist in a completely different universe; in a macro form.

Therefore, once they emerge from their cocoons they look like a semi-skeletal form of the being that they consumed (a rat would look vaguely rat-like, a human would look vaguely human, etc), albeit covered in a flesh-like material (appearing something like a desiccated corpse and about ½ the mass of the original creature/being). This flesh-like material is actually the bodies of millions (billions or even trillions) of micro-revenants taking the place of the flesh that had originally covered the endoskeletal structure. They work in unison to actuate the limbs in order to affect a mobility consistent with that which was originally enjoyed by the victim.

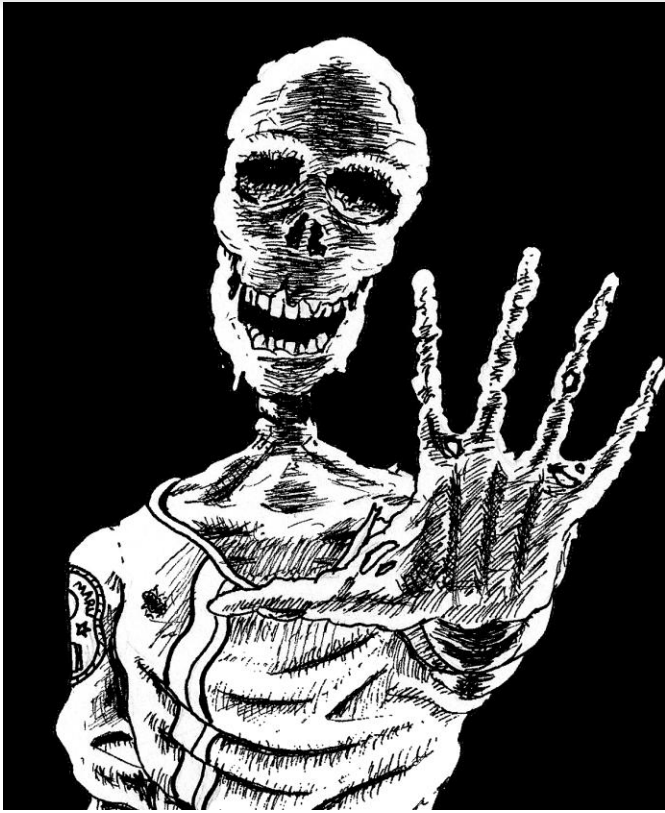

Revenant by A. J. Davis

They are completely unable to create flesh and are only approximating it in order to cover the skeletal framework and give them the ability to move on a macro scale. Similarly, they are completely unable to create organs; they have no need of them anyway. They can 'hear' and 'see' by using their cilia to perceive sound, like sonar. They also cannot speak in this form, except with each other as they have no way of creating vocal cords by which to express themselves in a manner compatible with such forms of communication. They can however, understand verbal speech just fine, as long as they have previously assimilated a victim with knowledge of the language being spoken.

One of their weakness' however, is that they are effectively using their purloined skeletal system as a marionette. Which means that they have very limited fine motor control. They can affect melee combat as effectively as the original victim could have. They can even do other things like fire weapons (they never have to bring the weapon to their shoulders to aim however, as their perception is 360 degrees and does not originate from eyes, but rather, their whole body is a sensory organ) and operate computer systems. What they cannot do is fabricate or repair such technology on their own because it takes fine motor control to construct fine circuitry and whatnot. Sure, they may know how to do it, but their

digits/appendages simply will not allow them to do so no matter how dexterous the original host had been. They would therefore, have a need to appropriate whatever goods they require rather than relying on producing it themselves. In a pinch, they could use their hosts (during stage 3 of infection) to produce something. This would present some barriers however as the third stage of infection only lasts a couple days (+/-). They could conceivably change out hosts as needed but this measure would be pretty extreme. The possibility however, does exist.

Poor fine motor control also means that they are a bit slower to react to stimuli than your average human (-5 DEX/RS and -1 Initiative).

Another weakness of the revenants is their communication, although that is also one of their strengths. They can instantly speak to millions (billions, trillions, however many happen to be in contact) of individual micro-revenants simultaneously (strength) so long as they are all in contact with each other (weakness). This holds true with their macro form as well. Each macro form is a colony unto itself consisting of multitudes of individual revenants. But in order to communicate with another such colony, the two would have to be in physical contact.

The revenants have worked around that limitation to a degree, by keeping any area that they inhabit moist. Macro-revenants moving about will therefore remain in constant contact with micro-revenants moving about the moisture of their surrounding environment and in turn, with any other macro-revenants in the area. This also means that, for any creatures/species other than revenants, revenant controlled areas are biological hot zones where simply moving about is deadly unless bio-hazard precautions are strictly adhered to.

Once a macro-revenant has left that moist boundary however, they are effectively on their own. Thus, working in conjunction with each other over long distances is very difficult for revenants.

When fighting with a macro-revenant the GM should use the average abilities of the assimilated victim for the macro-revenant's abilities. For example; a giant creature assimilated by a revenant colony had an average stamina of 400. The new macro-revenant will also have a stamina of 400. Exhausting the stamina of a macro-revenant does not kill the thing. It only means that enough damage has been done to the

endoskeletal structure to render the macro-revenant incapacitated. To destroy the creature it would have to be burned, bleached or some similar method of destruction would have to be employed. This does not suggest that the creature will eventually heal and become ambulatory again. It simply means that the micro-revenants involved are still very much alive and still very infectious. Touching the 'corpse' will cause infection. It should be noted that using an explosive device on such a creature could, in the long run, prove disastrous. Because doing so will distribute live micro-revenants over a large area and indeed, could 'splash' the creatures onto unprotected creatures/beings and in essence, aid in the distribution of the revenant colony(s).

Any physical contact with a micro or macro-revenant outside of strict quarantine protocols will result in revenant infection.

Ability Scores (these ability score adjustments supersede the ability score adjustments listed for any victim of revenant assimilation):

STR/STA	+0
DEX/RS	-5
INT/LOG	+10
PER/LDR	-5
IM	-1

Examples:

Weak revenant stats (with a core four host):	
STR/STA	35/35
DEX/RS	30/30
INT/LOG	45/45
PER/LDR	30/30
PS	+2
IM	2
Ranged	15 (stat) + 10 (skill) = 25
Melee	18 + 10 = 28
Skills:	
Ranged	1
Melee	1
GM's choice of 4 more skills all at level 1	

Average revenant stats (with a core four host):	
STR/STA	45/45
DEX/RS	40/40
INT/LOG	55/55
PER/LDR	40/40
PS	+3
IM	3
Ranged	23 + 20 = 43
Melee	20 + 20 = 40
Skills:	
Ranged	2
Melee	2
GM's choice of 6 more skills all at level 2	

Skills are to be assigned at the discretion of the GM. For example, an average revenant that had used one of the core four races as a host might have a beam weapon skill of 2 if the GM wished to make them average and perhaps a skill level of 4 if the GM wished them to be tougher.

Revenants have no appreciation of art. The concept of family is completely alien to them. They have no regard for sentient life, anything consisting of animal protein exists to be consumed by them. They view any other race as nothing more than a source of food.

Communication is simply a means to direct their numbers in order to attain more food to continue to grow. They have no desire to 'talk' with their food and attempting to do so will only give them time to infect the speaker.

The death(s) of other revenants mean nothing to the ones left alive; they have no regard for grief. Similarly, they have no appreciation of sympathy, honor or anything remotely related.

They exist in order to expand. *That*, they comprehend all too well.

When using this entity the GM should be aware that they could have a vast knowledge (depending upon how advanced the GM wishes them to be) and should be played as such. These beings would be extremely cagey and tactically smart. They should not be played as if they are simple animals or stupid in any way.

Note:

For the sake of simplicity, this body of work was written from the perspective of the revenants interacting with other creatures consisting of an endoskeletal structure. These beings can interact in a similar fashion with any fleshy organism (dralasites with no skeletal system at all and/or creatures which utilize a carapace/exoskeleton like vrusk) in a similar fashion. In fact, they would likely prefer assimilating creatures that have exoskeletons because that would provide more protection and security for the inhabiting colony.

In the case of a fleshy creature with no skeletal system, the revenants infect, consume and assimilate them in the same fashion. But the end result is akin to a mucous-coated micro-revenant being viewed on a large scale. Instead of swimming about their environment however, this form of macro-revenant would move about hydrostatically using the combined efforts of the colony to do so.

Epsilon Section:

Some other possible scenario ideas involving this species:

If the GM has chosen to use the 'plague worlds' depicted in Zebulon's Guide to Frontier Space in a fashion that departs from the explanation outlined in that work then this species could be used in place of the blue plague. The GM could choose to have this species originate on one of those plague worlds or could choose to have the species 'delivered' to the chosen planet on a crashing piece of debris or a meteor, etc.

The planet may have an established population which would find itself faced with annihilation as a result of ecological contamination by this species. Once this species starts making its way through a population it would be extremely difficult to stop.

The GM could handle this a couple ways. The PCs could be on the planet at the time of exposure, thereby allowing the GM to build an 'apocalyptic' scenario for the PCs to play through. The goal could be to escape the planet free of infection or to find a cure after having been blockaded by the military and placed in quarantine. This could be a beginner or mid-level scenario for new(er) characters/players.

Or the PCs could be part of a specialized team sent to the planet after the quarantine has already been put in place in order to ascertain what has happened and if the planet can be saved. This could be a higher level scenario involving heavy reliance on medical and technical skill sets – a more cerebral scenario if you will – as the PCs race to find a cure while dodging macro-revenants and uninfected citizens with an 'every-man-for-himself' attitude and a twitchy trigger finger.

The origin of this species has been left completely open so the GM will ultimately have the freedom to explain their origin however they wish (if they even wish to provide an explanation). One possible origin for this species is the sathar. The sathar are well known genetic engineers/manipulators and something like this could enable them to completely wipe out the population of a planet with a single microbe-seeded meteor. Of course, that could mean that the planet would then be tainted and uninhabitable. Some GMs may view the sathar in their universe as a race that ultimately wants those planets for their own agenda. Making planets too dangerous to inhabit might be completely counterproductive. When imagined, this species was intended to be free of sathar manipulation. Still, it is a possibility and should be left to each GM to consider for their universe.

Regardless how the GM utilizes this species (assuming that the GM chooses to use them at all), this species is intended to create a horrific setting in which to play. The GM is encouraged to heavily lace any encounter with this species with as much tension and dread as they can manage.

Zeta Section:

Credits:

Writer/Story: Rollo (Ben Gorman)

Editing: Lauren Wise & Terl Obar

Alien Consultant: AZ_Gamer

External Sinca Maru Ship Design: Jedion357

Graphics Consultant: Terl Obar

Eta Section:

Maps & Things:

Sinca Maru Top Down View

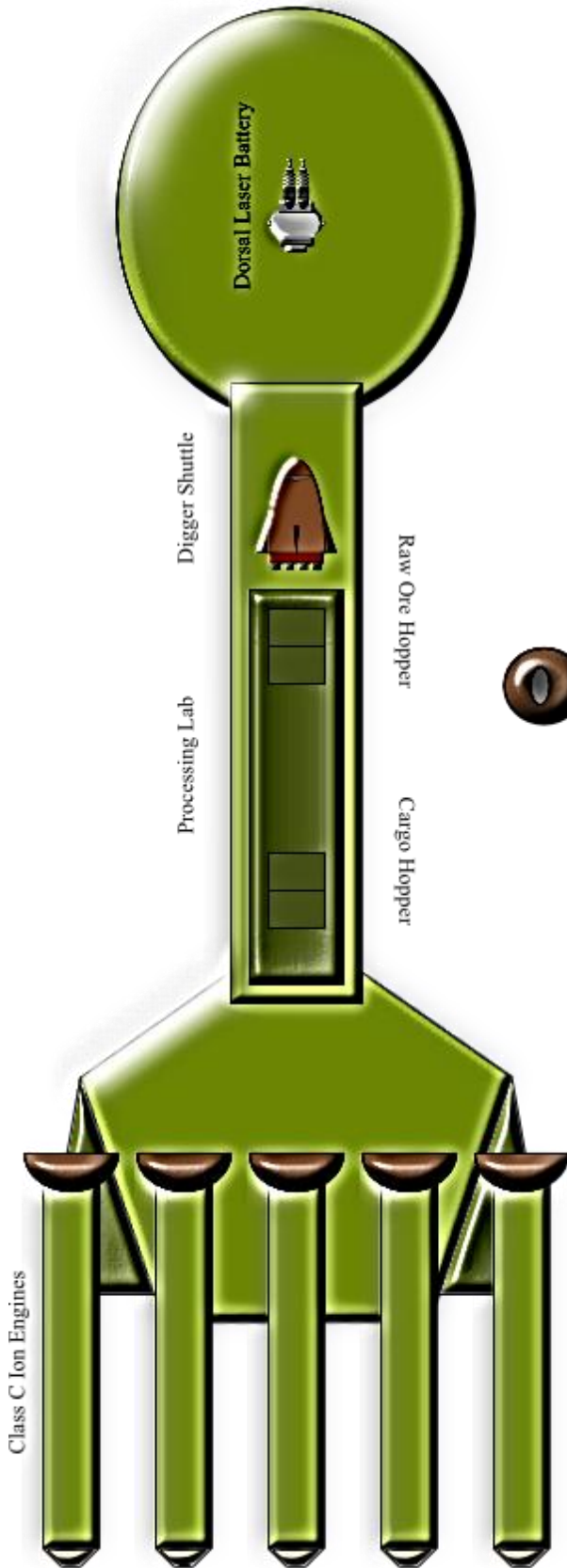

Sinca Maru Rear View

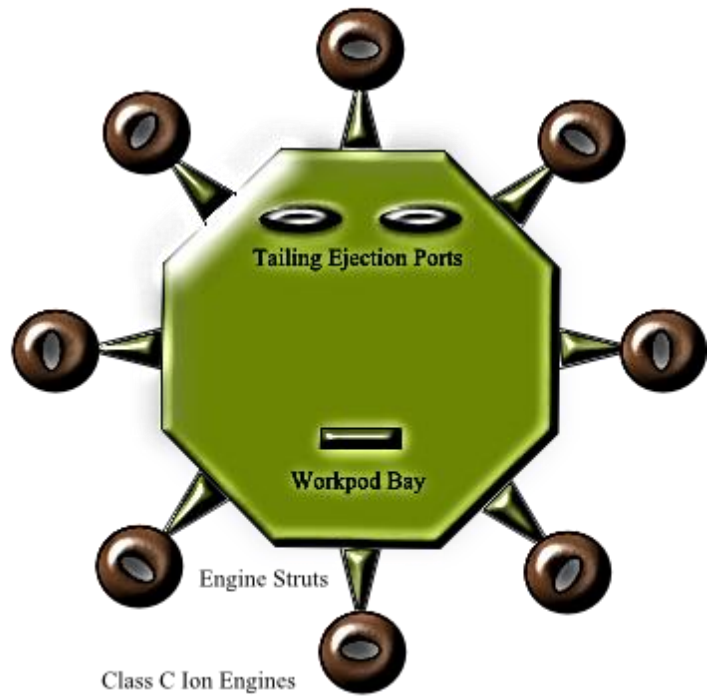

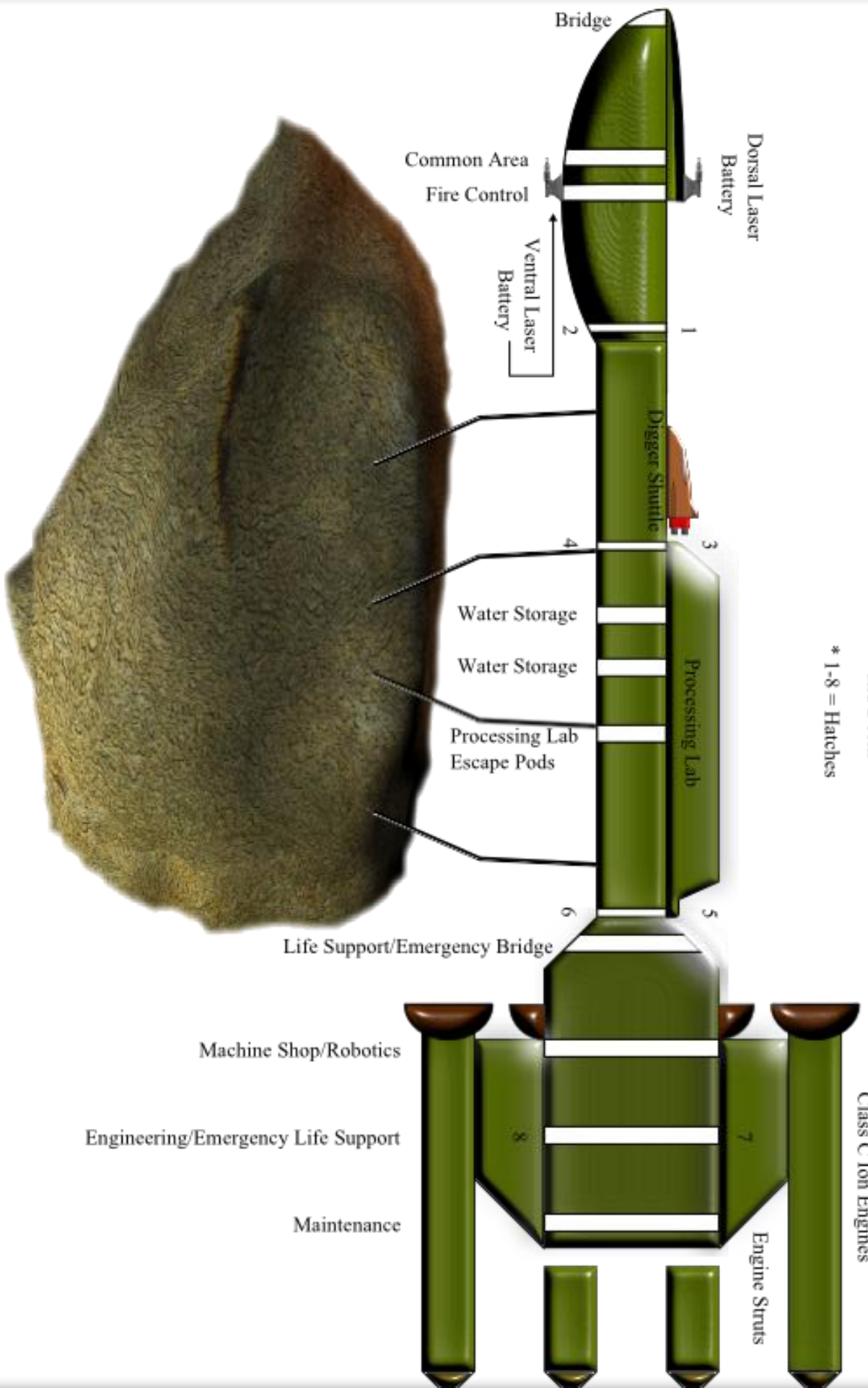

Sinca Maru Side View
and Decks

* 1-8 = Hatches

- 1 Elevators
- 2 Escape Pod Access
- 3 Weapons Locker/Storage
- 4 Head
- 5 Storage
- 6 Captain
- 7 Astrogation

Sinca Maru Bridge

- 8 Mining Ops
- 9 Pilot
- 10 Communications
- 11 Engineering
- 12 Weapons
- 13 Conference Room
- 14 Captain's Lounge

Scale: ■ = 1 meter

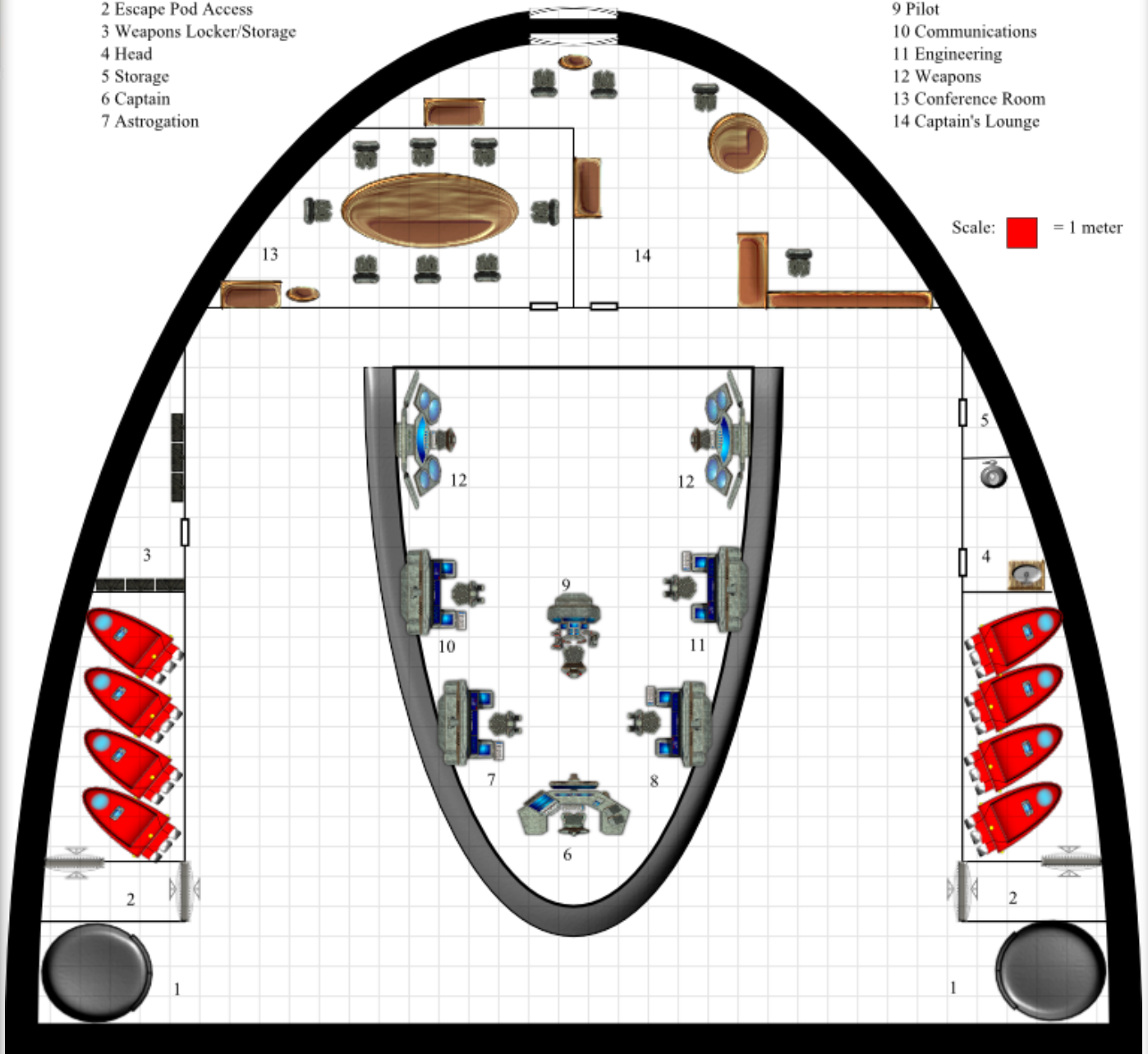

- 1 Toilets, Lockers & Showers
- 2 Storage
- 3 Kitchen Storage
- 4A Infirmary
- 4B Surgery
- 5 Crew Quarters
- 6 Life Boat Access/Emergency Equipment Storage

Sinca Maru Common Area

- 7 Life Boats
- 8 Galley
- 9 Cafeteria
- 10 Recreation Room
- 11 Elevators
- 12 Officer's Quarters
- 13 Mechanical Room/Plumbing

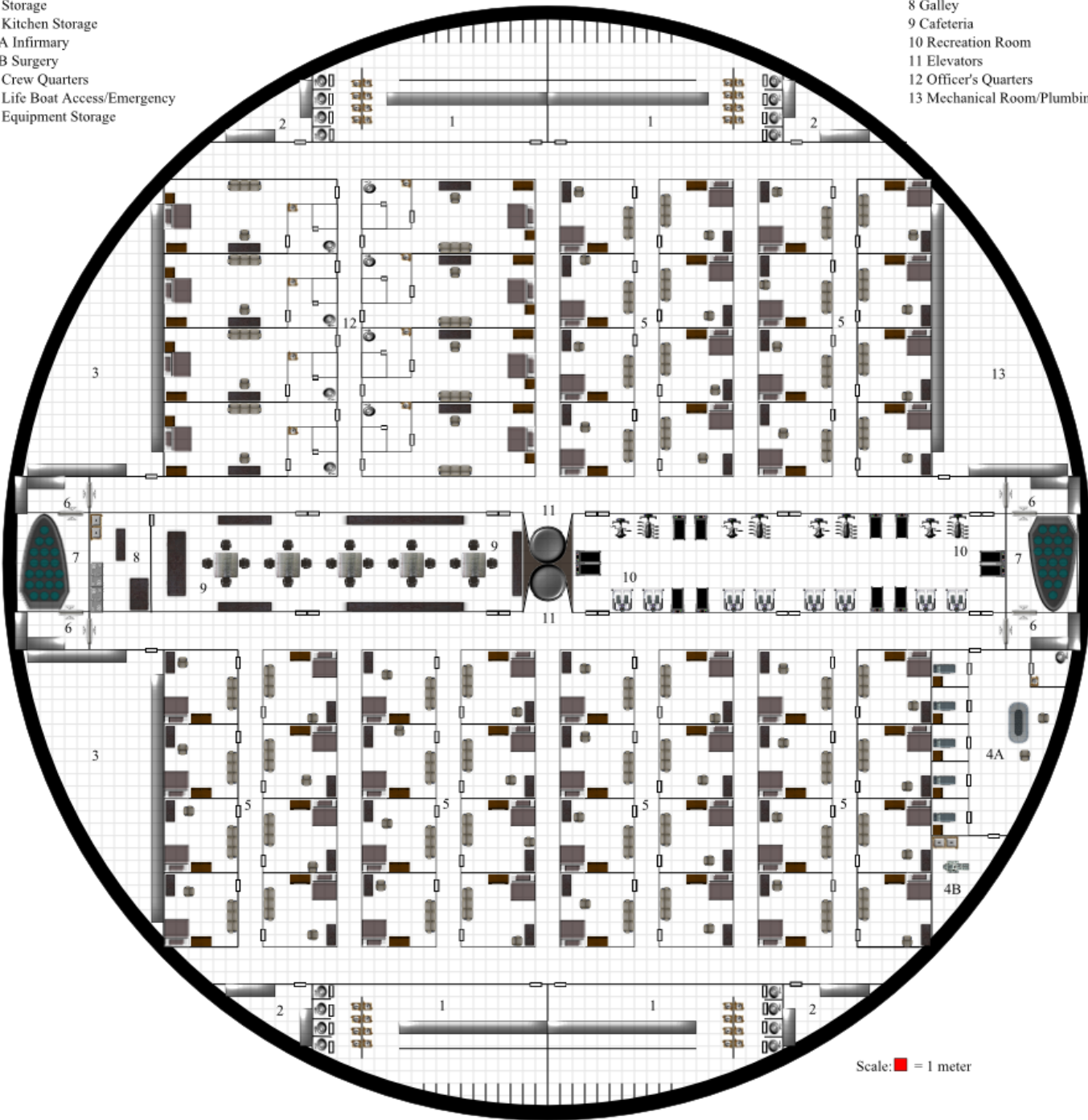

Scale: ■ = 1 meter

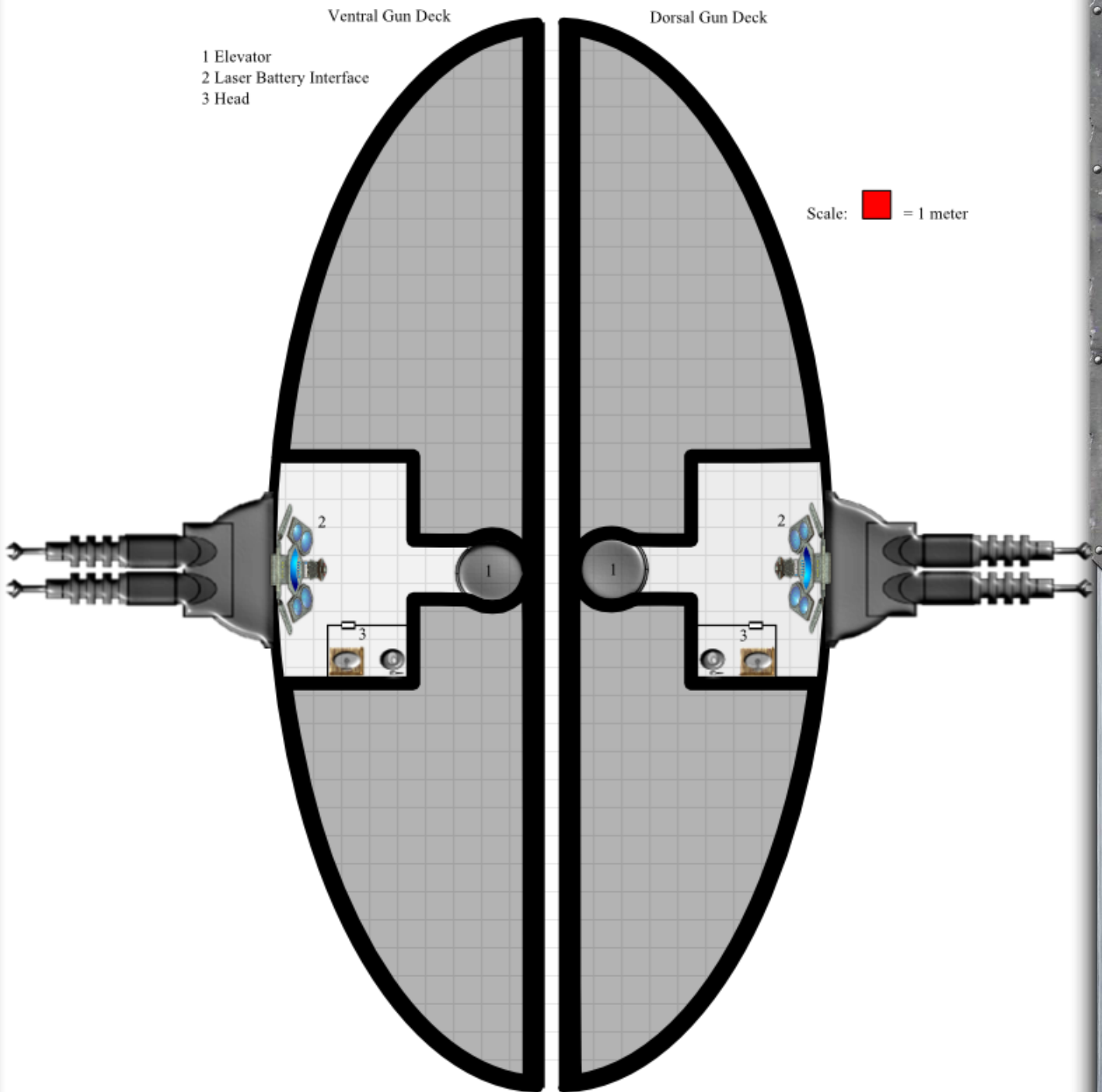

Sinca Maru Processing Lab

- 1 Head
- 2 Airlock Access to External Hatches 3-4
- 3 Airlock Access to External Hatches 5-6

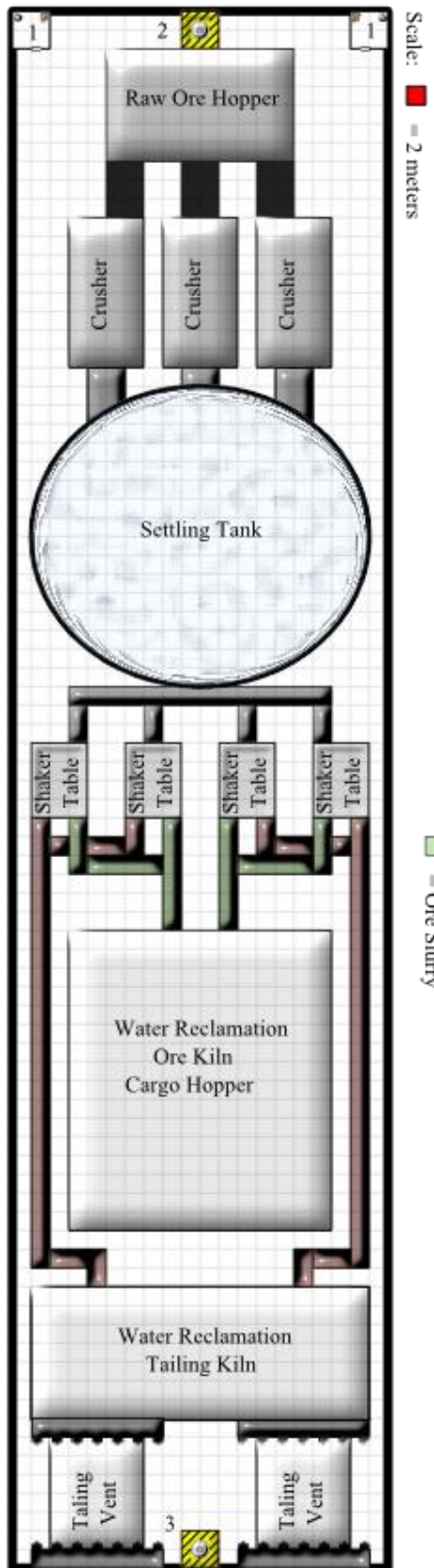

Sinca Maru Processing Lab Escape Pods

- 1 Elevator
- 2 Pressure Door

Scale: ■ = 1 meter

- 3 Escape Pod
- 4 External Bay Door

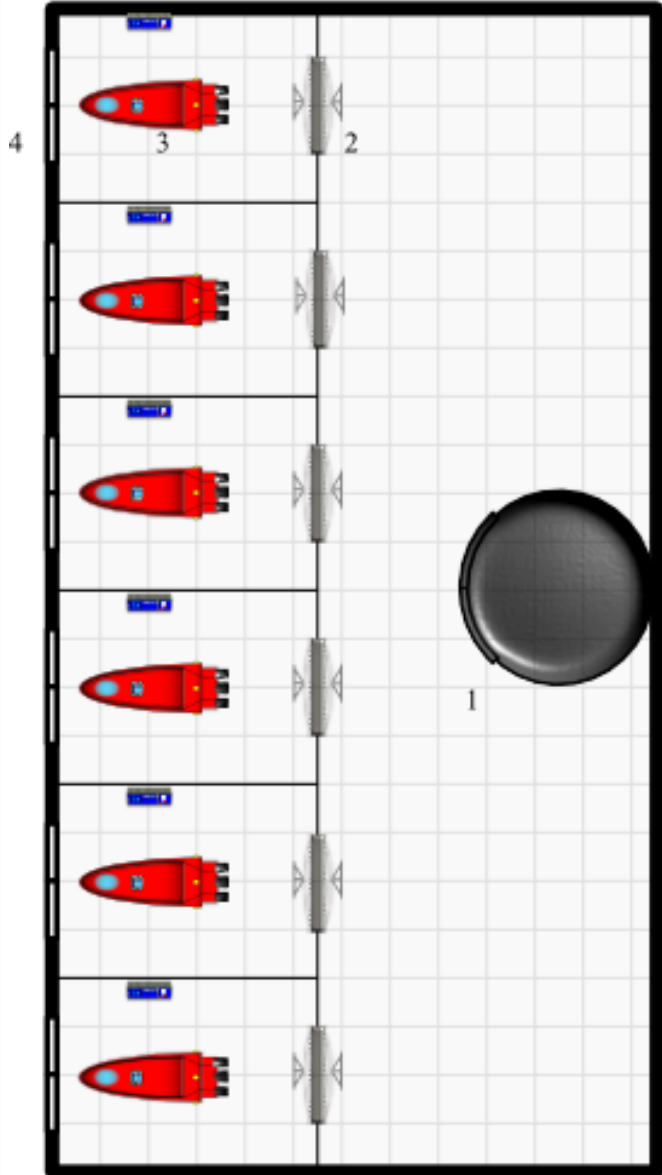

Port (Left) Escape Bay

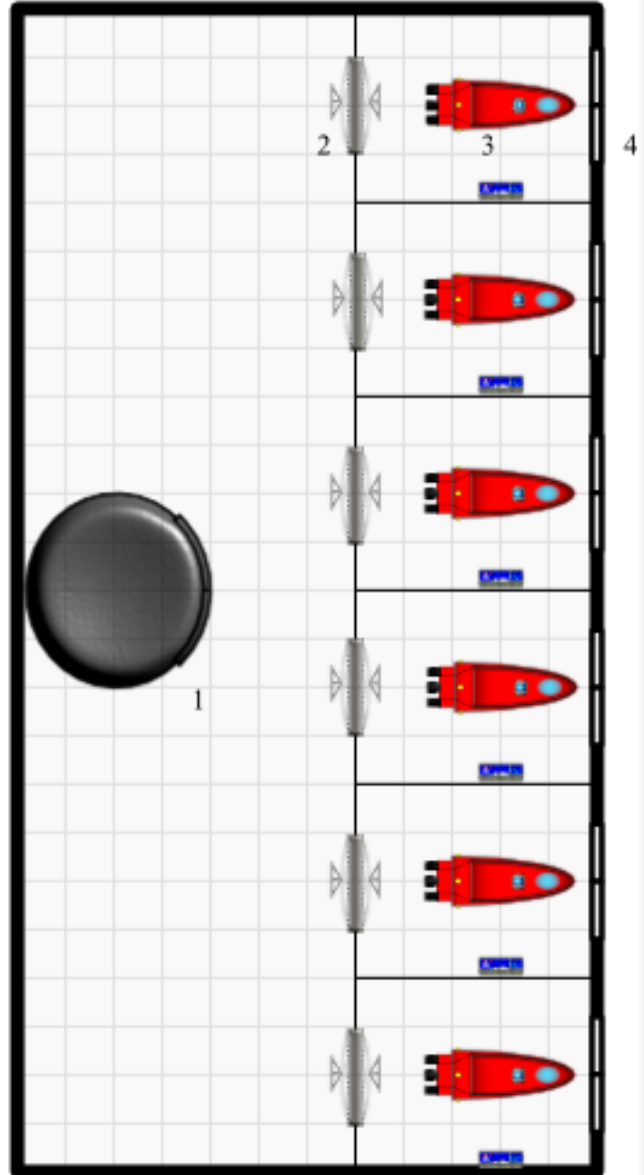

Starboard (Right) Escape Bay

- 1 Elevator
- 2 Life Support Equipment & Interface
- 3 Head
- 4 Captain
- 5 Pilot

Sinca Maru Life Support And Emergency Bridge

- 6 Weapons
- 7 Astrogation
- 8 Communications
- 9 Mining Ops
- 10 Engineering

Scale:  = 1 meter

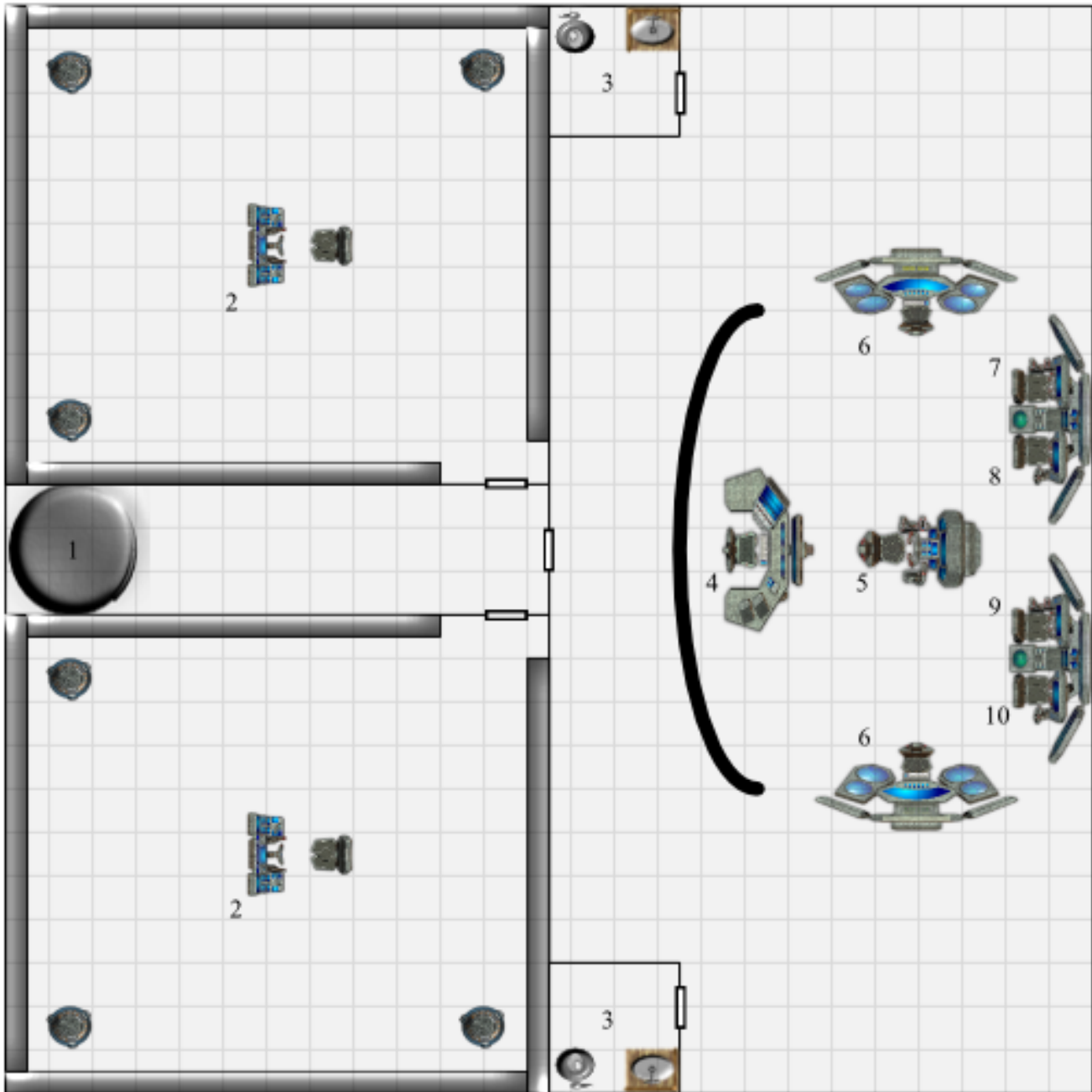

Sinca Maru Machine Shop & Robotics

- 1 Elevator
- 2 Liquid Industrial Components
- 3 Head
- 4 Industrial Saw
- 5 Pressurized Vat

- 6 Work Table
- 7 Large Storage Conex
- 8 Industrial Drill Press
- 9 Parts & Equipment Storage Lockers

Scale:  = 1 meter

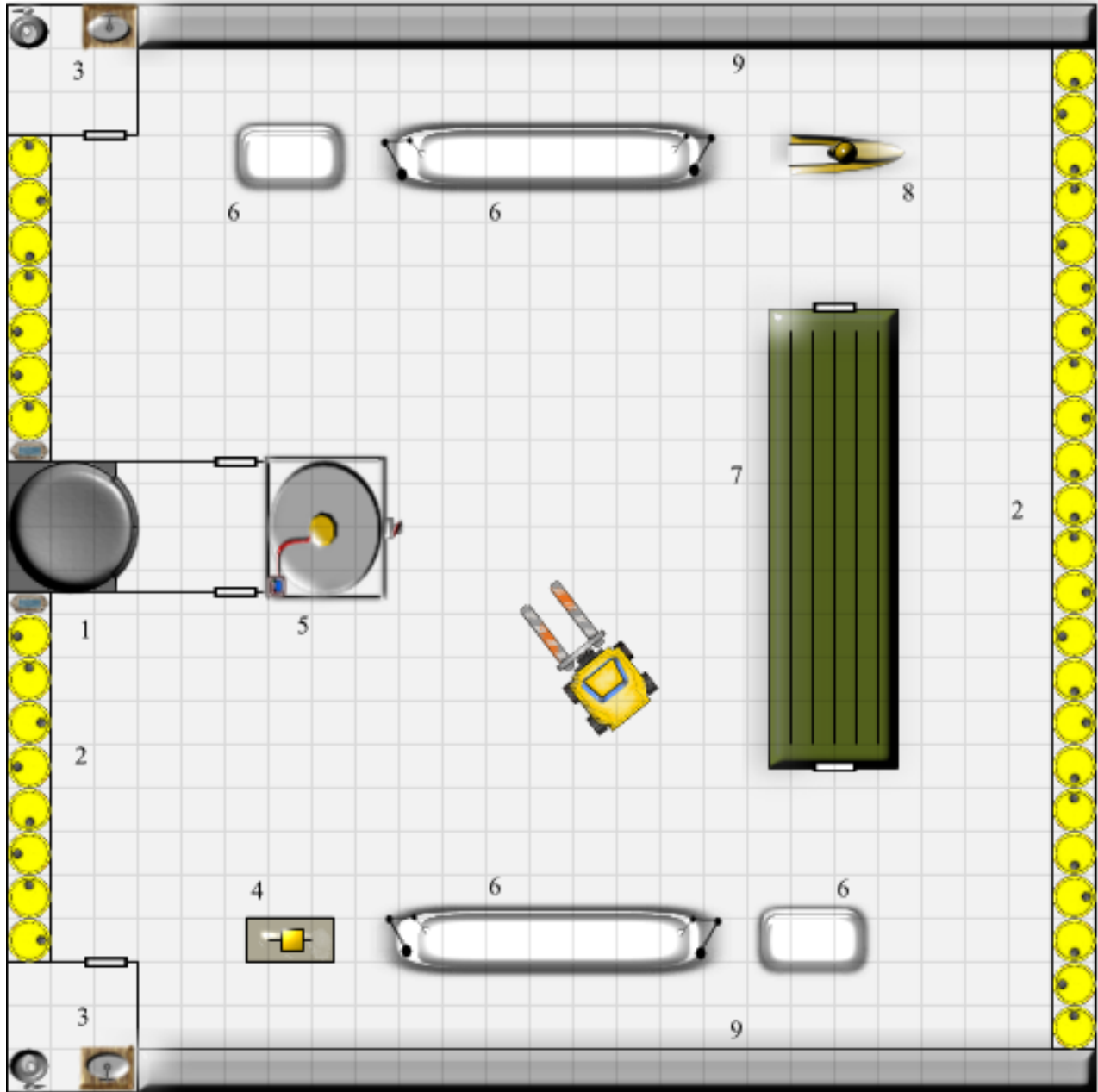

Sinca Maru Engineering And Emergency Life Support

- 1 Elevator
- 2 Life Support Equipment & Interface
- 3 Head
- 4 Work Bench

- 5 Computer Console
- 6 Storage
- 7 Equipment & Parts
Storage Lockers

Scale:  = 1 meter

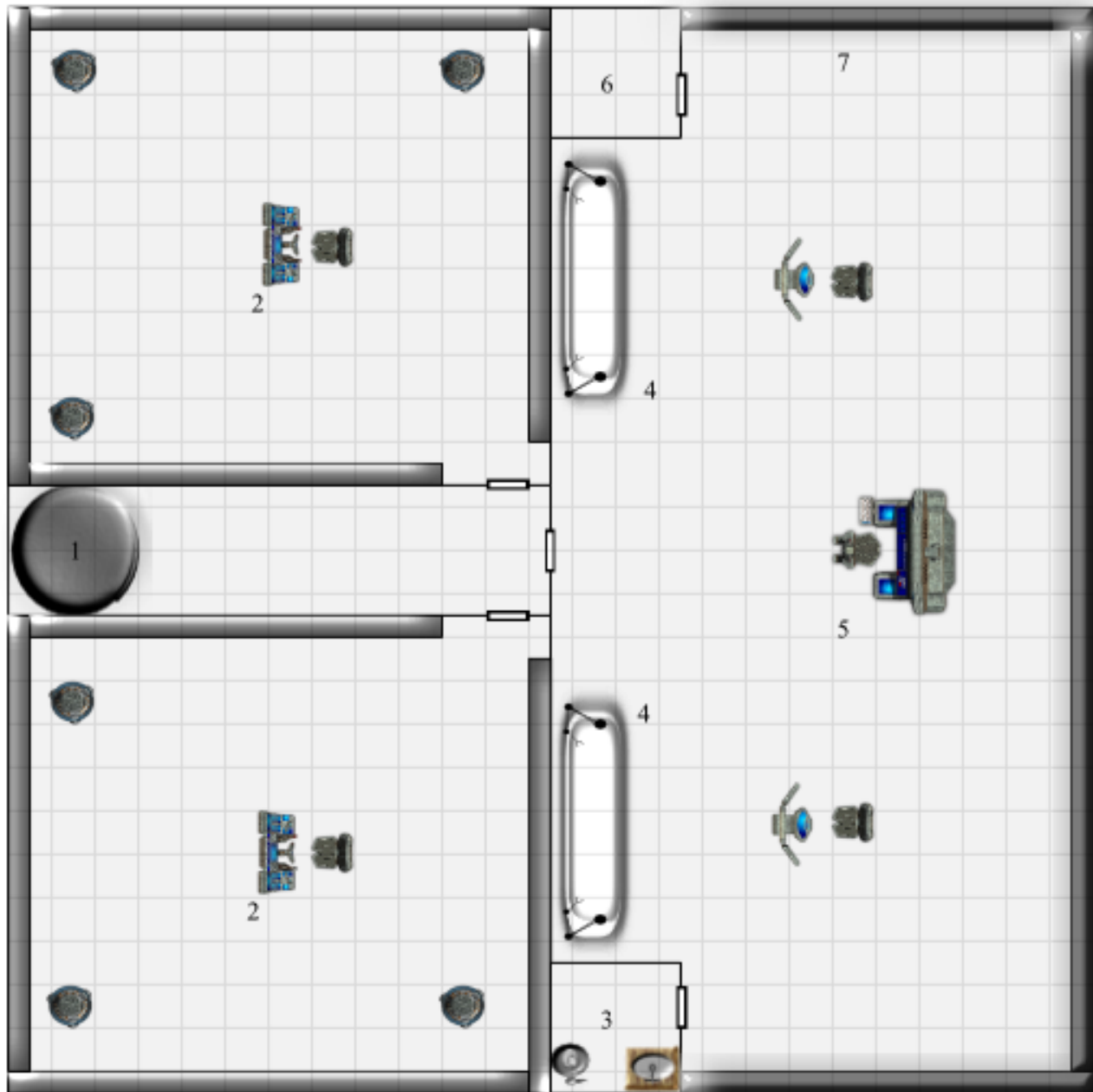

Sinca Maru Maintenance

- 1 Elevator
- 2 Large Storage Conex
- 3 Head
- 4 Repair Bay

- 5 Operator Equipment Storage
- 6 Workpod Launch Interface
- 7 Workpod Launch Bay
- 8 Industrial Liquid Components

Scale:  = 1 meter

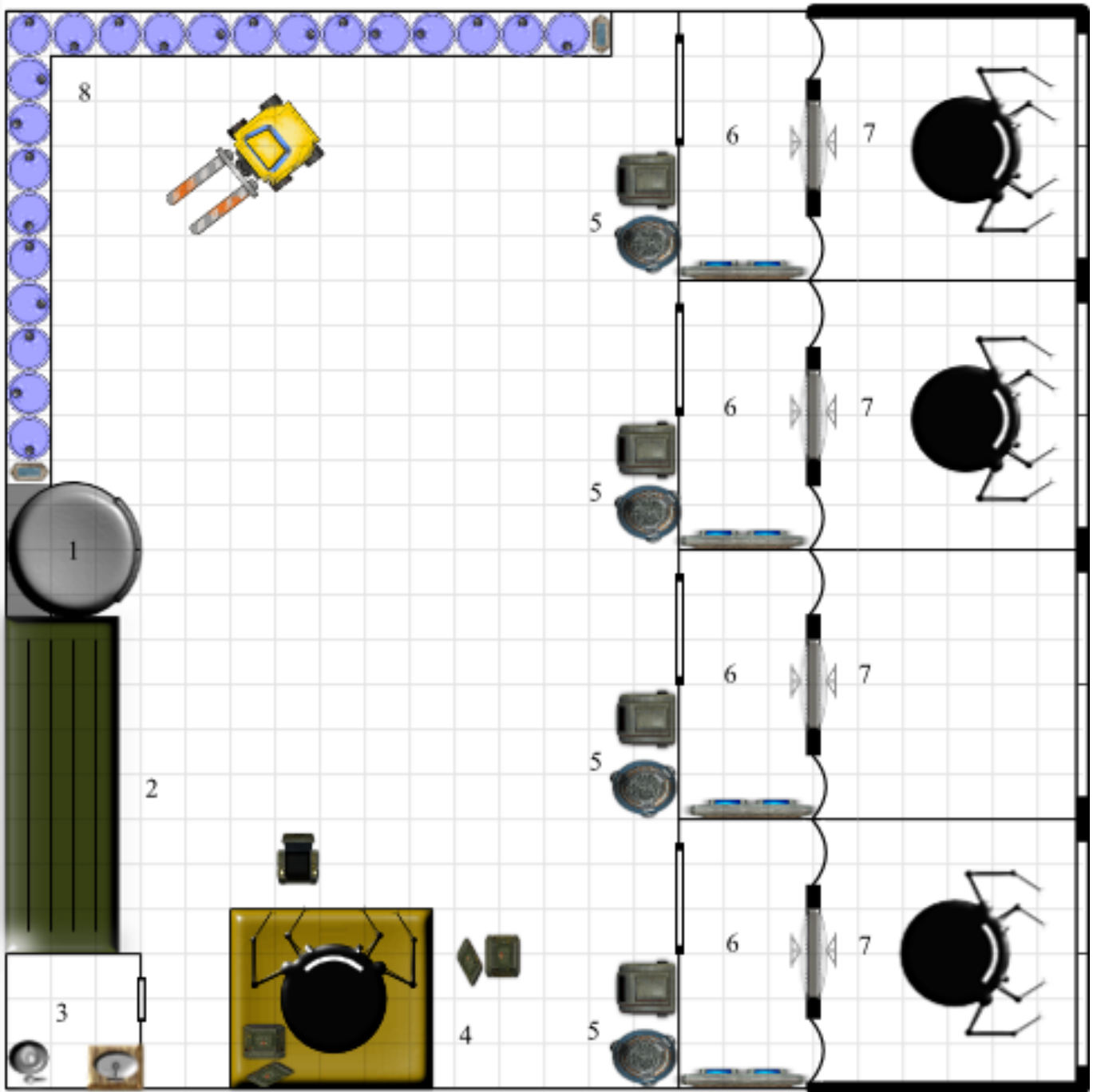

SPACESHIPS

Gold Star Cruise Lines

By Steven Parenteau

Gold Star Cruise Lines was founded in 86FY by (Bara Satara) and (Sebastian Vanko). The company is a subsidiary of Trans Travel and specializes in running non-military personnel in comfort (sometimes in extreme luxury) through the main star routes of the frontier. As with all of Trans Travel companies, Gold Star holds the majority of the market shares. In the passenger cruise line business, Gold Star has approximately 65% of the frontier market shares.

The company has become known as one of the first pioneers across the frontier to not only transport passengers but give them a pleasant journey so they arrive happy. Gold Star was the first passenger liner to remove a deck of cabins and replace it with gaming machines. This simple changeover was an immediate success among customers.

The first ship Gold Star purchased was a left over destroyer hull modified and refit with state rooms and a dining room. It was renamed the "Antares". Later, a game room was added to the ship. This popular refit enabled the company to be profitable enough to purchase another used destroyer hull which was renamed "Rigel".

Trans Travel saw the potential in "Comfort Passenger Liners" and funded the purchase of two new space liners. They were a new design dubbed "Constellation" class. The first two Constellation class ships were named Hydra and Perseus. The new ships had larger hulls (size 8), had more efficient use of space to accommodate larger state rooms, and had comfort built in rather than have additions added later. In addition, the Constellation class ships had lower operating costs because it used ion drives while the converted destroyers used atomic power to save on long term operating costs. The company built a total of 8 Constellation class liners in total from 89FY to 100FY.

With the success of the Constellation class star liners, Gold Star added a new class of liners: the Galaxy Class. This new liner design made Gold Star the unquestioned leader of the comfort liner business. These new ships had a rotating section for the passengers to maintain gravity at all times. The cargo and crew areas still operated the same as the other ships by maintaining gravity through acceleration. The Galaxy liners used ion drives for a gentle ride and were much larger in size (hull size 12). Due to the larger size of these ships, a special docking connector was needed to lock to the stations.

Ship Name	Ship Class	Year Built	Years in Service	Hull Size	HomePort
Antares	Viper (UPF)	40FY	86FY-102FY	6	Gran Quivera
Rigel	Viper (UPF)	41FY	88FY-104FY	6	Minotaur

Ship Name	Ship Class	Year Built	Years in Service	Hull Size	Home Port
Hydra	Constellation	89FY	89FY-Present	8	Triad
Perseus	Constellation	91FY	91FY-Present	8	Hentz
Cepheus	Constellation	93FY	93FY-Present	8	Teledrom
Andromeda	Constellation	94FY	94FY-Present	8	Golloywog
Virgo	Constellation	96FY	96FY-Present	8	Gran Quivera
Taurus	Constellation	98FY	98FY-Present	8	Forge
Leo	Constellation	99FY	99FY-Present	8	Ken'zah-kit
Draco	Constellation	100FY	100FY-Present	8	Moonworld

Ship Name	Ship Class	Year Built	Years in Service	Hull Size	Home Port
Milky Way	Galaxy	102 FY	102FY-Present	12	Gran Quivara
Andromeda	Galaxy	104 FY	104FY-Present	12	Minotaur
Bode	Galaxy	105 FY	105FY-Present	12	Hargut
Mayall	Galaxy	107 FY	107FY-Present	12	Pi'Ka'Nair
Sombrero	Galaxy	108 FY	108FY-Present	12	Kidkit
Tadpole	Galaxy	109 FY	109FY-Present	12	Exodus
Messier	Galaxy	111 FY	111FY	12	Inner Reach



Starship Leo

By Steven Parenteau

Constellation Class

Star Liner

The Constellation class star liner was designed by Gold Star Cruise Line Company to replace their aging converted destroyer cruise ships. These liners were designed in 87FY and the first hull (the Hydra) was laid the same year at the Triad ship yards in Cassidine.

The Constellation liner design was a radical spin off from the earlier cruise line designs. The most noticeable feature was the use of 4 ion engines instead of the typical two ion engines used by other liners of the same size. Although this increased the cost of building the liner, the overall operation and dependability of the vessel was greatly enhanced. Ion engines are cheap to operate and low to maintain. If an engine issue were to happen during travel another one kicked into gear.

The second change was the addition of life boats on every berthing deck. The hull had to be specially fitted for this modification since most constellation sized liners would only have 1 or 2 life boats while this liner had 9. The additional life boats were added so all personnel on board would have the ability to get off the ship in the unlikely event that everyone would have to abandon ship.

The first Constellation liner, the Hydra, left the Triad shipyard in 89FY and spent two weeks in a shakedown cruise before returning. It then took up the route to Gruna Garu. Gold Star produced 7 more Constellation class ships before replacing them with the Galaxy Class Liners in 102FY.

- **Deck 1:**
 - **Bridge:** Seats for the pilot, co-pilot, navigation, communication and captain. Also on this deck is the captain's office along with his stateroom.
- **Deck 2:**
 - **Flight Crew Staterooms:** Staterooms for both on duty and off duty flight deck crew.
- **Deck 3:**
 - **Sickbay:** Ships sickbay with the onboard doctor's stateroom.
- **Deck 4 through Deck 7:**
 - **Journey Class Berth:** There are nine journey class berth rooms per deck plus a storage closet for supplies and linen changes. Each room can be converted to a single large size bed.
- **Deck 8 and 9:**
 - **First Class Berth:** There are five two room suites on this deck

along with a steward's quarter that holds 4 crew members to cover late night calls from the first class decks. There's also a storage closet for supplies and linen changes.

- **Deck 10:**

- **Storage Berth:** Four rooms each contain 16 stasis pods for a total of 64 pods for the most economical transportation possible.

- **Deck 11:**

- **Game Deck:** Various forms of entertainment is available to keep passengers busy during their long trips through the stars. Games include the standard like roulette, black jack, slot machines, plus many other various versions of card games. There is also a full service bar

- **Deck 12:**

- **Dining and Club Deck:** Dining center for the ship plus the kitchen and a full service bar.

- **Deck 13 and 14:**

- **Crew Deck:** Staterooms for the ship's crew plus a storage closet for supplies and linen changes.

- **Deck 15:**

- **Storage Deck:** Crew and passenger personal items are stored here.

- **Deck 16:**

- **Engineering:** Controls for the ships power generator and ion drive systems. There's also access to the four ion drives though access tubes.



Cloe by J.A. Davis

Constellation Class
Star Liner

Hull size...8
 Length...180
 Width...30
 Decks...16
 Hatches... 3
 Engines...4, Ion B
 ADF...1
 MR...3
 Computer...50FP
 Alarm...L3
 Lockout...L3
 Damage Con...L3
 Astrogation...L3
 Videocom
 Comm Screens...76
 Intercom
 Mics...76
 Subspace radio
 Radar
 Portholes...93
 Reflective Hull
 Lifeboat...9

 Total=\$2,117,060

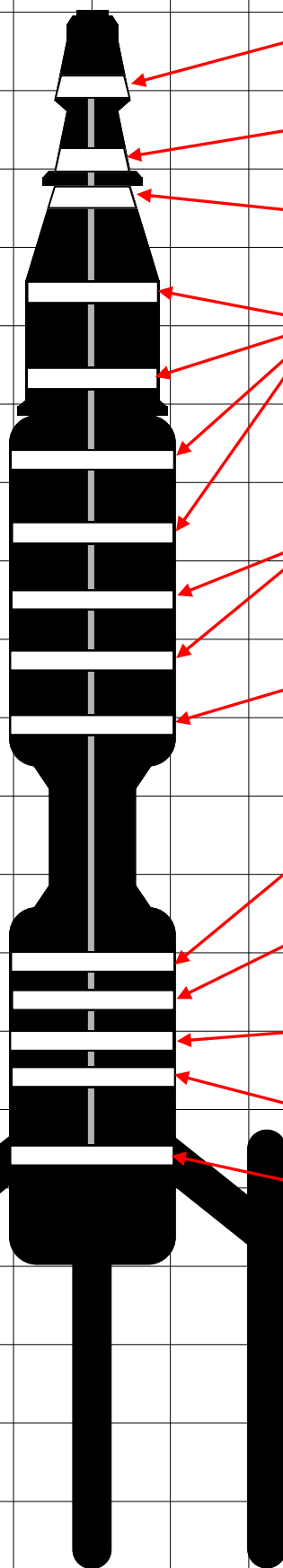
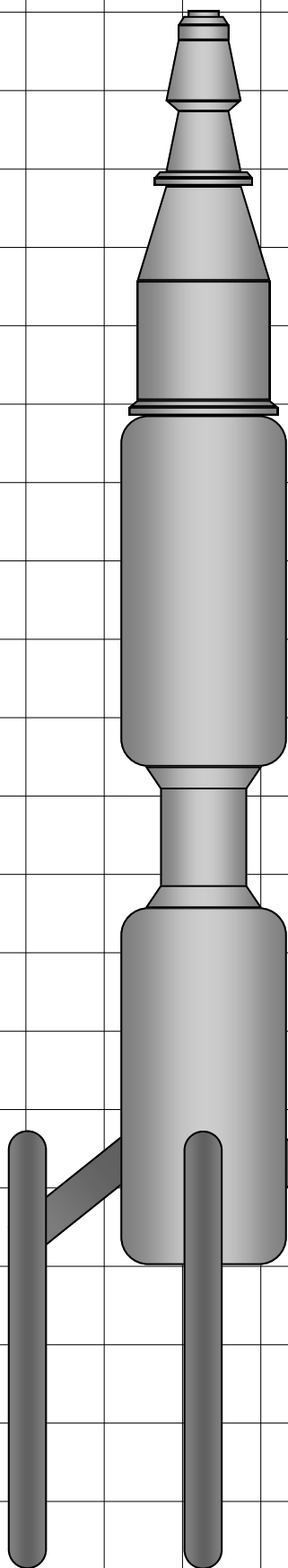

- Bridge Deck1
- Flight Crew Deck
- Sick Bay Deck 3
- Journey Class
Deck 4-7
- First Class
Deck 8-9
- Low Berth Class
Deck 10
- Game Deck 11
- Dining & Club
Deck 12
- Crew Deck 13&14
- Storage Deck 15
- Engineering Deck

Space Liner
Bridge
Deck1

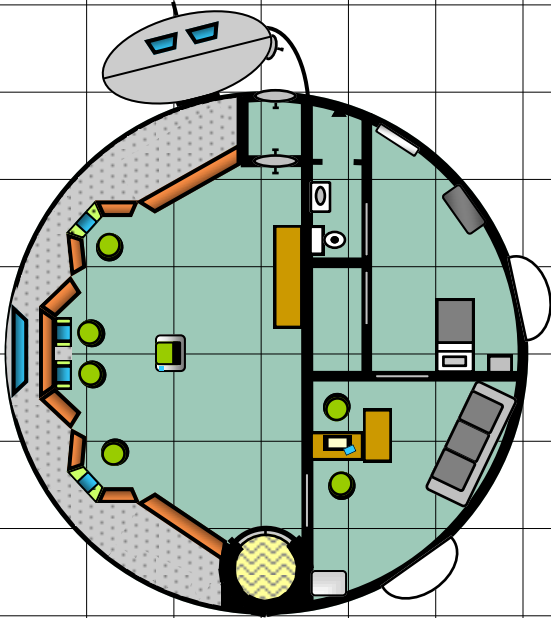

Space Liner
Flight Crew Deck
Deck 2

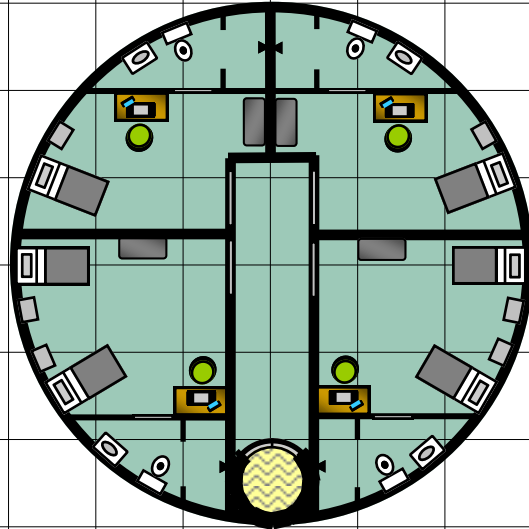

Space Liner
Sick Bay
Deck 3

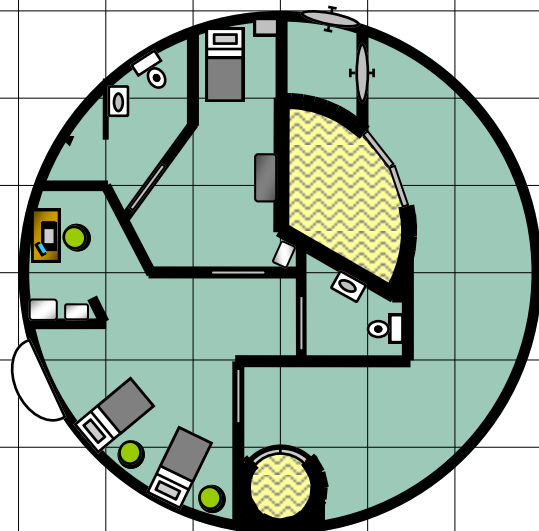

Space Liner
Journey Class Deck
Deck 4 thru 7

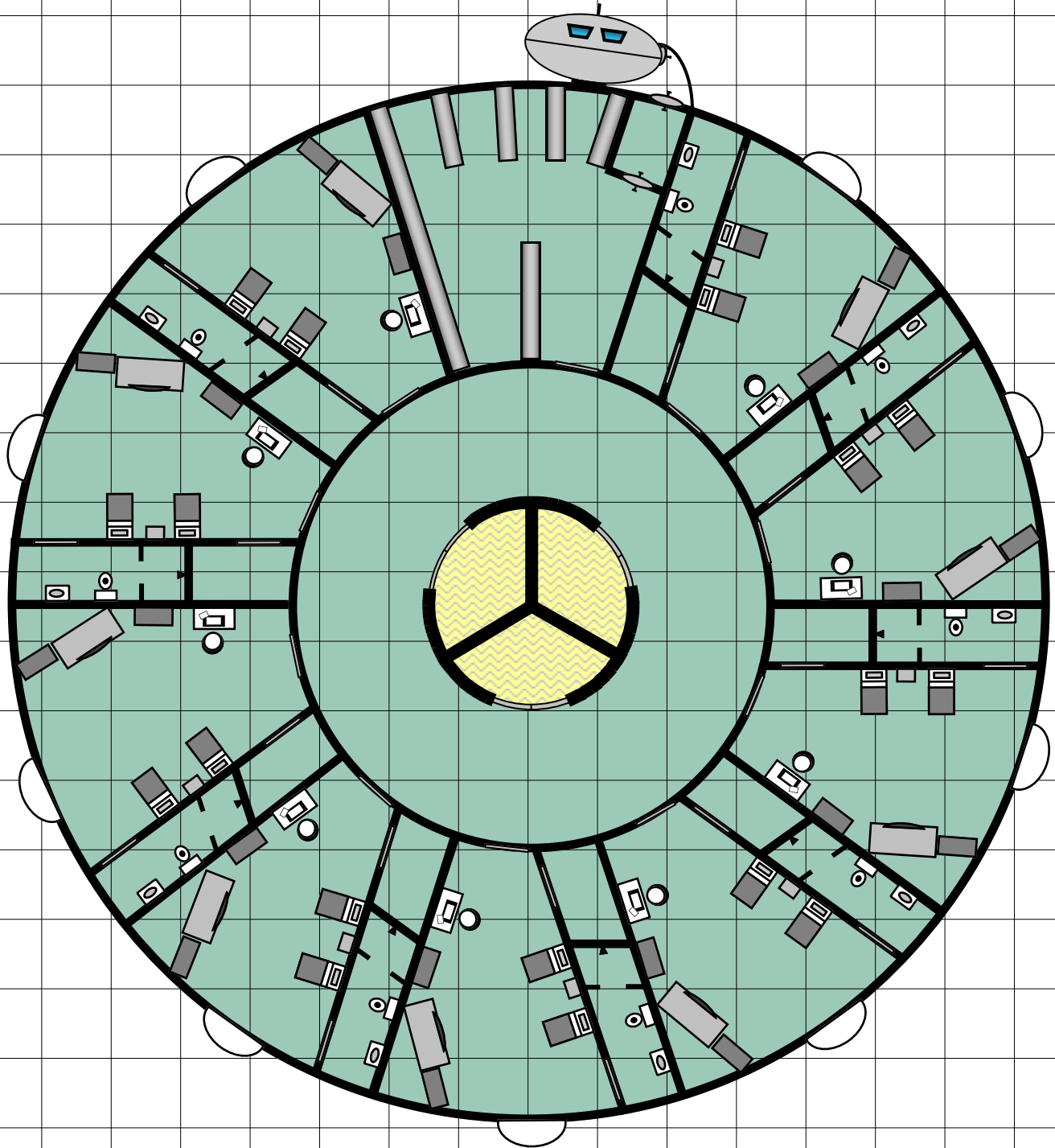

Space Liner
First Class Deck
Deck 8 thru 9

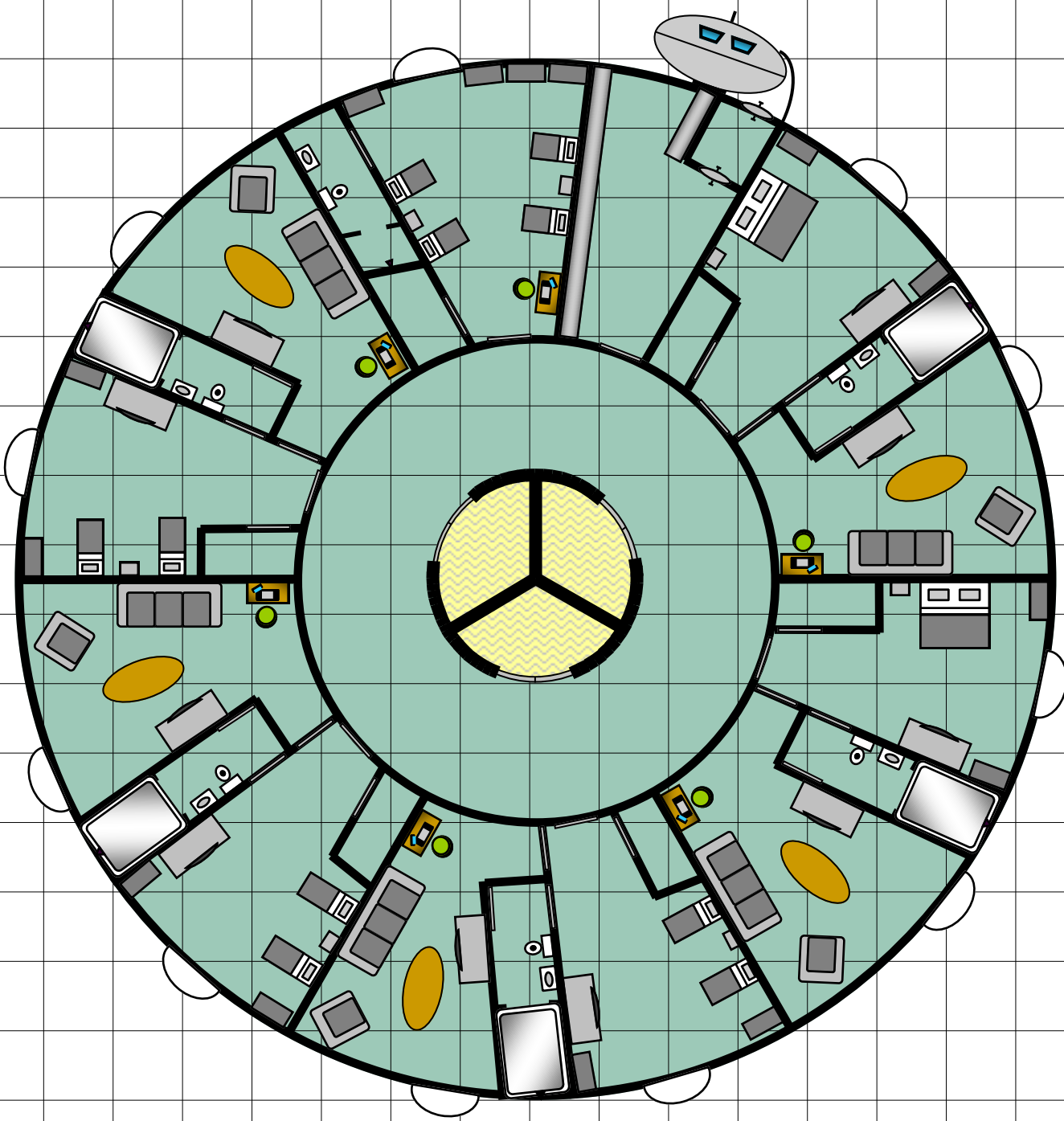

Space Liner
Berth Class Deck
Deck 10

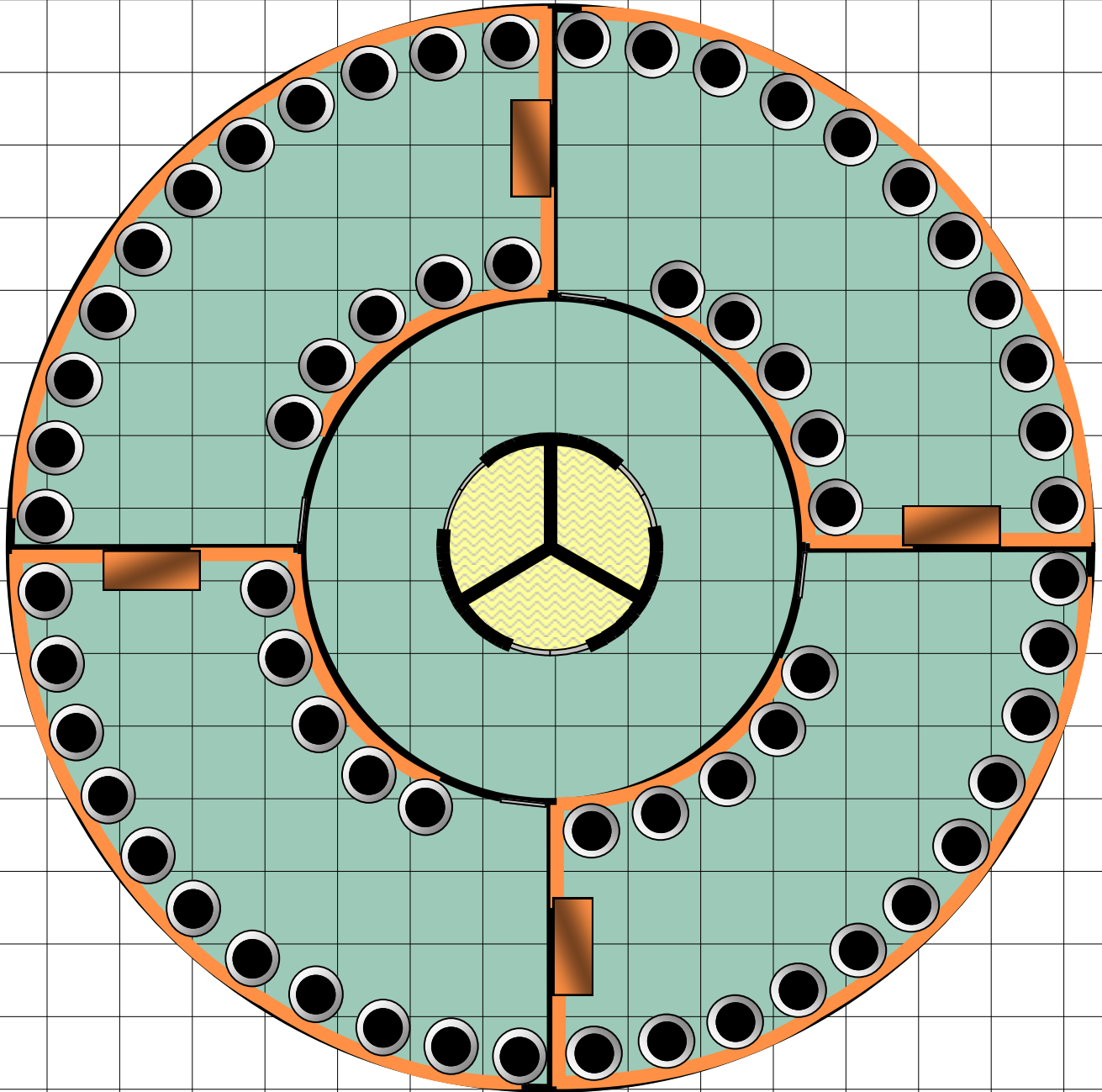

Space Liner
Game Deck
Deck 11

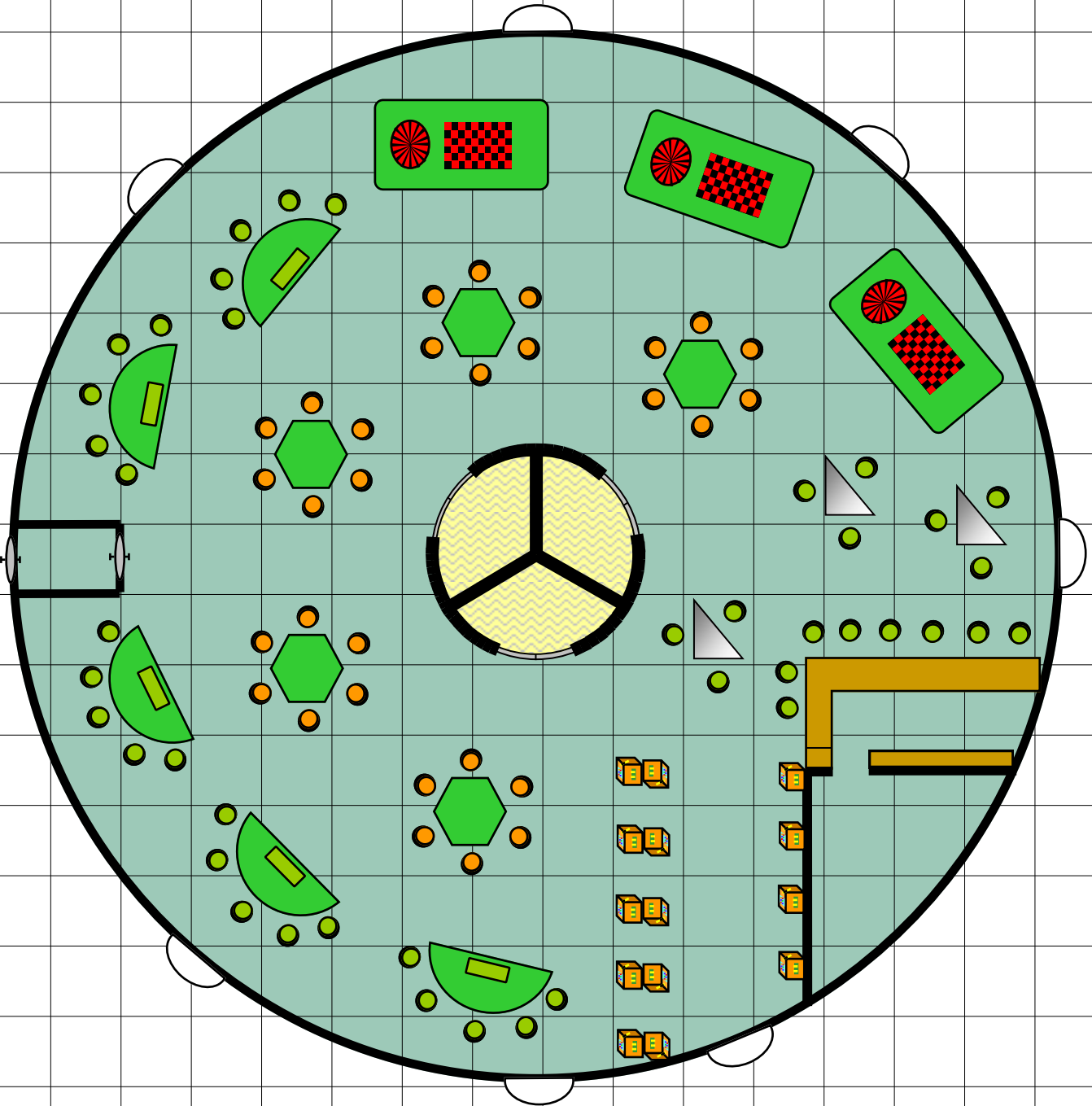

Space Liner
Dining and Club Deck
Deck 12

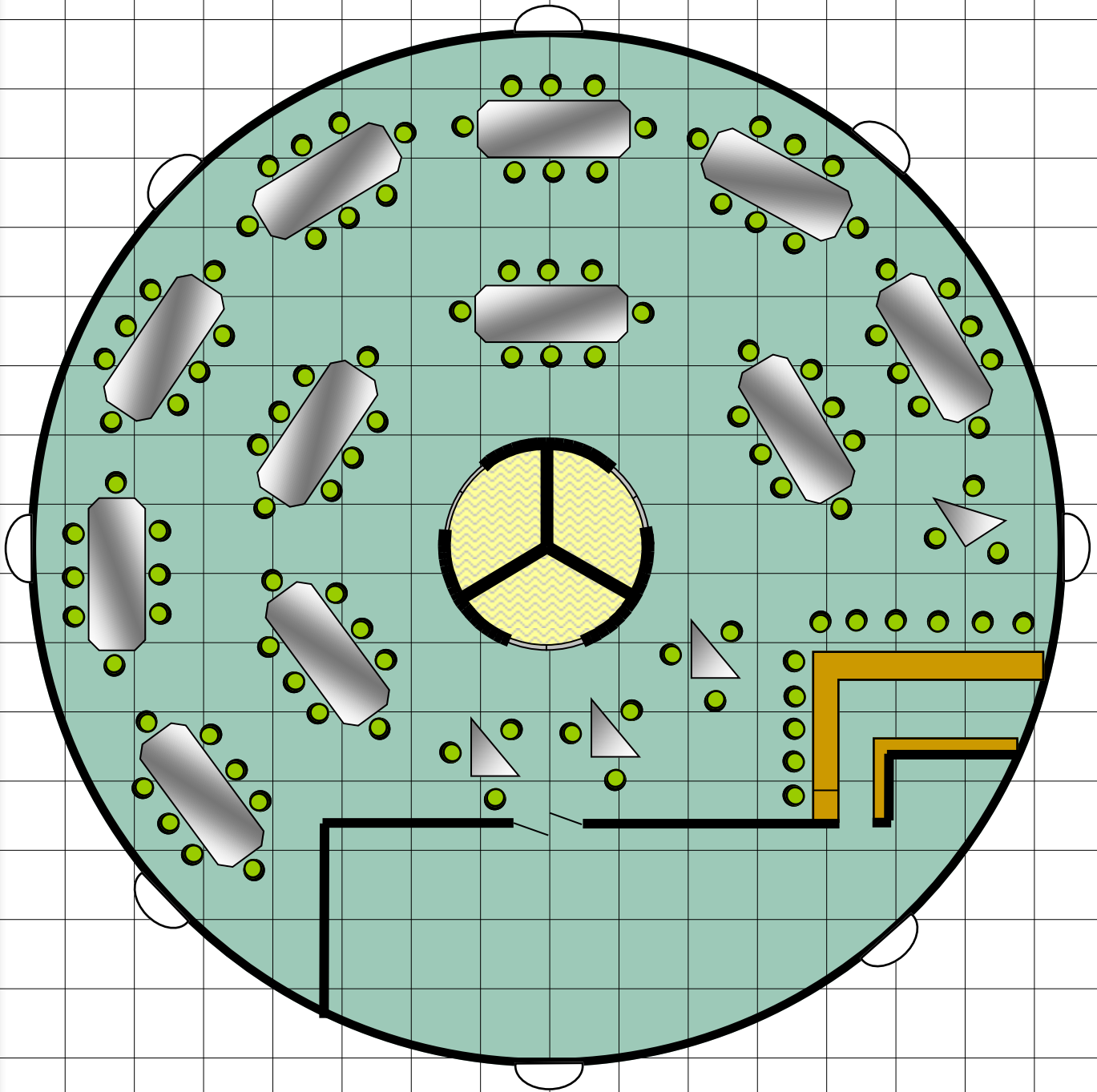

Space Liner
Crew Deck
Deck 13 thru 14

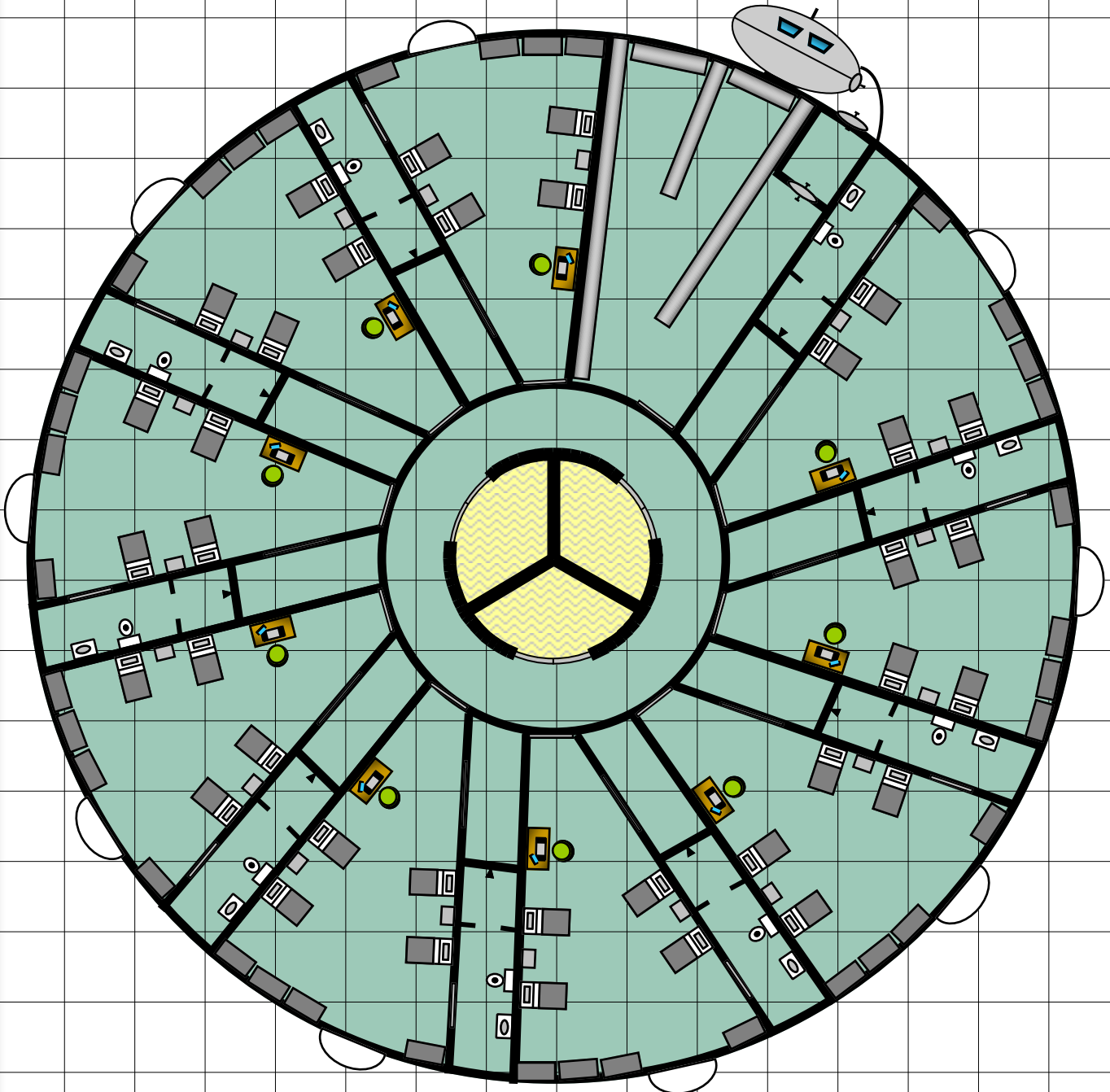

Space Liner
Cargo Deck
Deck 15

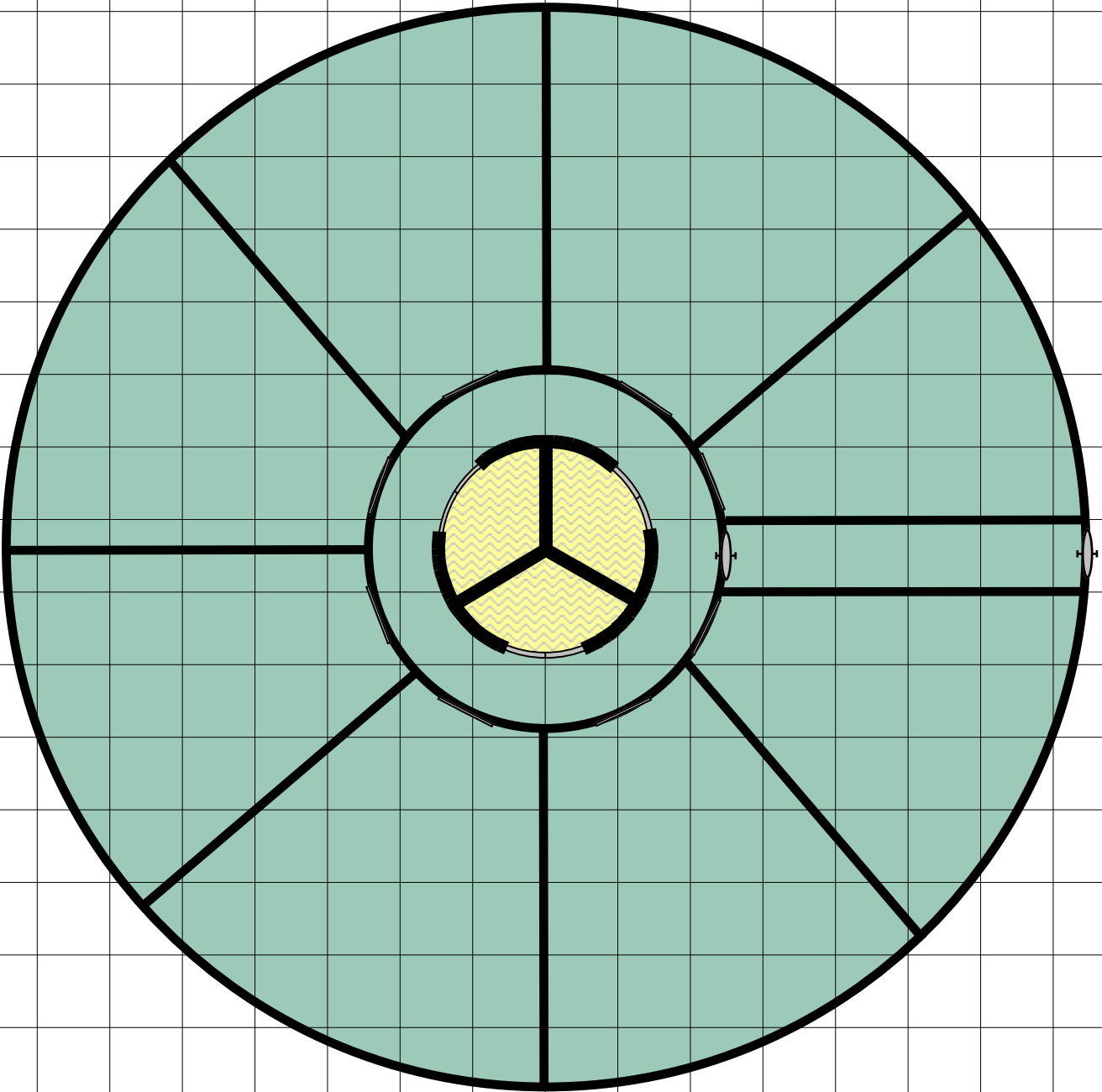

Space Liner
Engineering Deck
Deck 16

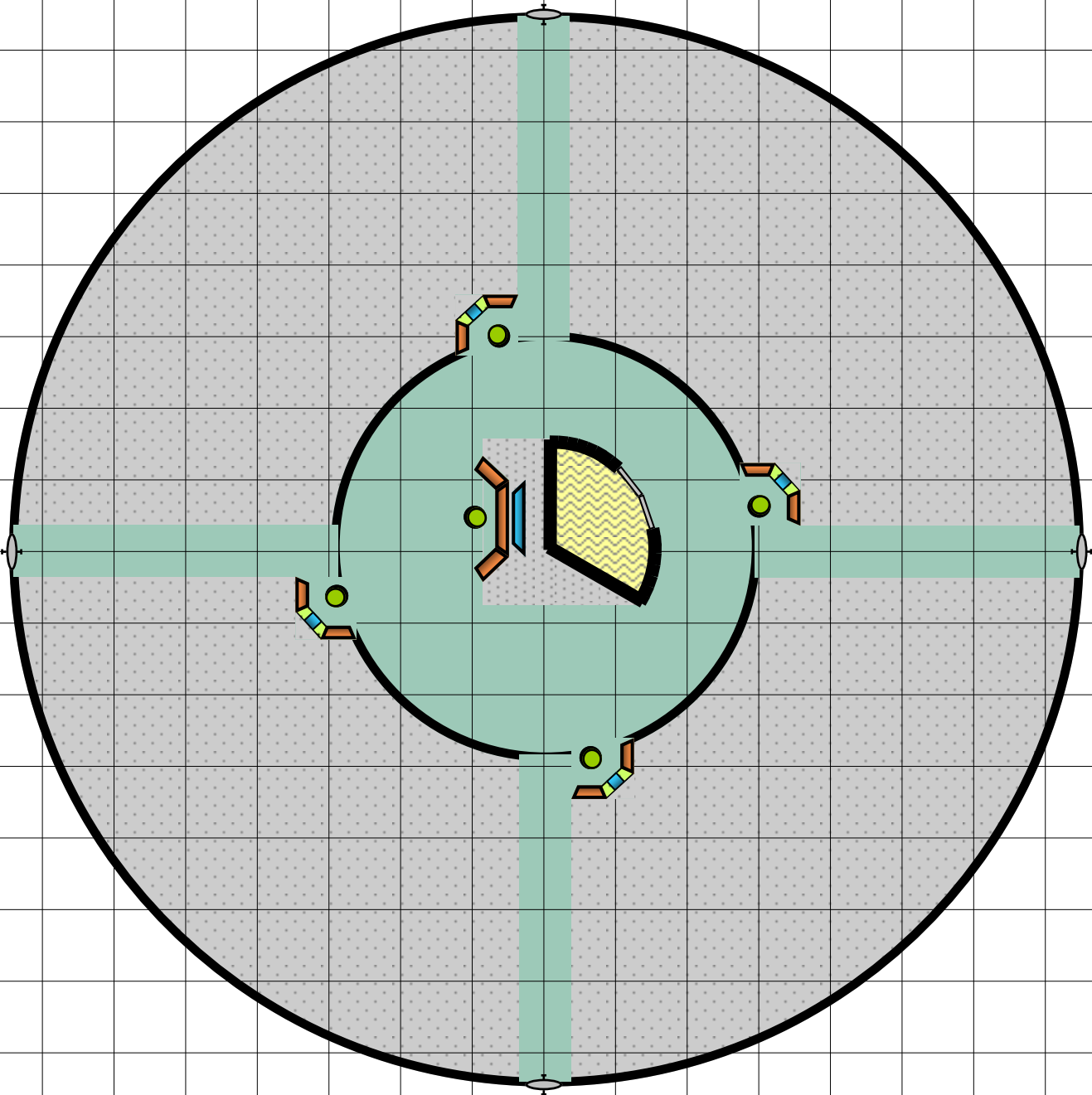

The Frontiers of Design

A new shipbuilding system for the STAR FRONTIERS® game.

By Mike Lane

Dragon #74 April 1988

Many STAR FRONTIERS® game players have problems when it comes to designing nonstandard military ships for use with the Knight Hawks board game and, as I can testify, it becomes rather nerve-wracking to be constantly asked "How many laser batteries can I put on this minelayer? Well, then, how many rocket battery salvos can it carry? Well, then. . ." and so on. Over many hours and some calculator thumping, a system that pleased everyone in my gaming group was generated. This system creates starships compatible with (if a little tougher than) those given in the board-game rules. The new ships also have a great variability in weaponry, which can make even a simple assault-scout duel quite interesting. The following sections deal with the shipbuilding formulas and overall system in depth. Tables 1-6 give details on the items discussed below.

Hull points and DCR

A civilian ship's Hull Points and DCR (Damage Control Rating) are determined as per the Knight Hawks rule book — i.e.,

Civilian

Hull Points = Hull Size x 5
DCR = (Hull Size x 3) + 20

Military and Star Law

Hull Points = Hull Size x 10
DCR = (Hull Size x 9) + 20

Military and Star Law ships multiply hull size by 10 to determine hull points and by 9 to determine DCR. The

greater values generated show the toughness and technical superiority of the secret military hardware over the civilian/ militia equipment, and result in fewer attacking ships being vaporized in the "Defensive Fire" phase of combat.

Weaponry and defenses

All weapons and defenses on a ship are placed according to the amount of space they occupy in cubic meters, as per the statistics on page 61 of the Knight Hawks game rules, rather than using the MHS (Minimum Hull Size) method. The MHS is still used as a measure of how many weapons of one type may be mounted on a certain hull.

The maximum number of each type of weapon on a ship may not exceed the hull size rating divided by the MHS of that weapon system. However, any ship with the necessary space may mount any one weapon despite its MHS. (Yes, you can have an assault scout with a laser canon!)

Table 1 Space Available by Hull Size

Hull Size	Military Ships	Civilian Ships
1	30	20
2	50	30
3	75	40
4	100	50
5	175	90
6	250	125
7	300	150
8	350	175
9	400	200
10	450	225
11	500	250
12	550	275
13	600	300
14	700	350
15	800	400
16	900	450
17	1000	500
18	1100	550
19	1200	600
20	1300	650

* All spaces given in cubic meters.

Defenses are also bought by the cubic meter, though no ship of less than hull size 5 can mount a powered defense screen because of the screen's heavy energy demands, which require the larger "B" engines.

The cubic meters of space for each hull size is determined by a decreasing percentage scale, with figures rounded to the nearest useful amount. This effectively reduces the free space on a battleship to about 1.6%, as compared to a fighter's 97%, which reflects the squeeze on space as life-support systems; crew quarters, storage areas, and so forth expand with ship size and potential patrol duration.

Table 2 - Weapon and Space Needed

* Assault rockets for rearming fighters kept aboard an assault carrier are kept in cargo space. Up to 15 per cargo unit can be carried.

Weapon	Cubic Meters	MHS
Laser cannon	40	5
Laser battery	25	3
Proton-beam battery	30	10
Electron-beam battery	30	6
Disruptor cannon	60	12
Assault-rocket launcher	10	1
Assault rocket*	10	—
Rocket-battery array	40	5
Rocket-battery salvo	10	—
Torpedo launcher	75	5
Torpedo	20	—
Mine spreader	60	7
Mines (5 fields)	20	—
Seeker-missile rack	40	7
Seeker missile	40	—
Grapples	60	5

It should be noted that noncombat ships such as freighters, research vessels, liners, and the like have only 40% of the space listed, since their primary functions demand nearly all available space. This is not to say that there could not be small capacity, heavily armed liners used to move VIPs; this simply means that such ships would not be self-sufficient and would thus be very rare.

Weapon magazines

Rather than saying that a certain number of rounds can be kept in a launcher, the cubic-meters system is used to determine the number of rounds carried. Thus, ammunition for assault rockets, rocket battery arrays, torpedo launchers, mine spreaders, seeker-missile racks, masking screen launchers, and ICM launchers are figured on a cubic-meters-per-shot basis, though one round (or one array, or 20 meters of mines) may be kept at no space cost in any launcher except a masking



screen launcher. This is because a masking-screen charge is larger than the launcher itself.

Space stations

Space stations come in four main categories: fortresses, fortified stations, armed stations, and unarmed stations. The last title is something of a misnomer, as even the smallest freight station is likely to have a laser battery to discourage piracy.

Military stations fall in the fortress and fortified-station categories, while megacorporations have only a few fortified stations and many armed ones. "Free" stations not belonging to any one group or cartel are usually armed, though a few fortified and unarmed stations can be found. Small freight stations, scientific stations, and automated stations are usually unarmed.

Space-station weaponry and defenses are mounted in exactly the same way as they are on starships, with two differences: No forward firing weaponry may be mounted, and MHS restrictions are ignored with respect to the maximum number of one weapon type mountable. The statistics given on Table 6 refer to a single space-station hull of a given size. It should be remembered that more than one hull may be joined to create megastations, as per page 8 of the Knight Hawks rule book, though such huge stations are prohibitively expensive for all but the military and megacorporations of the largest size.

Miscellaneous items

Players and GMs will undoubtedly find new things to put on ships. By carefully determining an item's size, it can easily be integrated into this system. Remember, though, that addition of any item beyond the listed maximums reduces the ADF or MR of the ship by one.



Expanded Knighthawks Ship Design

By Andy Campbell

Introduction

The Knighthawks Rulebook laid out the basics of a MHS design system (primarily for adding weapons and defensive systems), but omitted coherent MHS guidelines for carrying fighters, small ships and civilian equipment. The original Knighthawks rules also failed to present an overall design framework using the MHS system, explaining the rationale behind Minimum Hull Sizes and how they could be used to design variant and entirely new classes of ships. This article attempts to correct these omissions.

The Minimum Hull Size System of Ship Design

Frontier ships are limited by the energy available from the ship's power plant, the power plant on all ships being the engines. Thus, the total equipment and armament capacity of a ship design is a function of how big its engines are, how many are mounted on the ship, and the efficiency of its engines. Military and paramilitary ships use advanced high-efficiency engine designs not available to civilian shipbuilders, thus they carry much heavier armament than civilian ships mounting engines of equal size and number.

Minimum Hull Size points represent not the volume or mass of a ship's systems, but the amount of power required to operate those systems. A given hull may have the physical space to mount a Laser Cannon, but if its engines lack the power to fire it there is no sense in installing the weapon. Likewise, a Proton Battery occupies just 30 cubic meters of a ship but has a MHS of 10; a Laser Cannon occupies 40 cubic meters of space but is only MHS 5 because it requires less power to fire.

Most ships have plenty of surplus volume in their hulls where weapons or other systems could be installed, but lack the engine power to operate those systems; this surplus volume is usually given over to extra cargo space, roomier quarters, bulkheads, etc. which draw minimal power from the engines.

Practical and Theoretical Design Limits

Although Frontier engines are extremely efficient, they do have their limits. Current military engines push the outer envelope of engine performance, and in many cases approach the efficiency limits of current Frontier engine design. There are two distinct limits on engine performance.

The first is the practical design limit, which represents the efficiency limit of current Frontier designs; the practical limit is expressed in terms of how much of an ADF penalty can be negated by the engine compared to a standard civilian design. The civilian design limit is equal to 1/2 the ship's hull size - ie. a hull size 6 ship can mount up to 3 MHS points of equipment without any loss of ADF or MR. By contrast, a hull size 6 destroyer mounts 34 MHS points of weapons and defenses but suffers no penalty to its ADF / MR; a civilian ship mounting a similar arsenal would be unable to move, suffering an ADF/MR penalty of 11 points. Therefore the simplest way to measure an engine's efficiency is by the number of points a similar civilian ship would be penalized.

The second engine design limit is the theoretical limit. Theoretical design limits of Frontier engines represent the absolute maximum MHS points that could be mounted on a ship with a given number and type of engines. Existing military ship designs are slowly approaching this point.

The following tables list the theoretical and practical MHS efficiency limits for ships' engines.

Practical Engine Design Limits

Ship Type	Efficiency Rating*
Civilian	1 Point (ie. if the total MHS points carried exceeds a ship's (HS/2) minus 1, the ship MUST lose ADF / MR points due to excessive equipment, as per the Knighthawks Rulebook, pp. 18-19)
Yacht**	3-6 Points
Privateer**	2-8 Points
Military	4-13 Points

*Put in simplest terms, the efficiency rating equals the number of ADF/MR points this type of ship design can ignore when the ship's limit is computed (as per Knighthawks "Limits" section, p. 19). When the number of lost ADF / MR points is calculated in Step 4 (top right column of p. 19), instead of 1 subtract the ship's efficiency rating (it will still be 1 for civilian ships, but will vary for other ship types). Any leftover ADF / MR points must be deducted as normal, but if the result of Step 4 is lower than the ship's efficiency, NO ADF / MR penalty is applied.

**Yacht- and Privateer-class ships were detailed in DRAGON issues 86 and 88; the "official" statistics for them were given in "Yachts and Privateers Return" by Douglas Niles in DRAGON 88.

Theoretical Engine Design Limits

Engine Size A (hull sizes 1-4):	Maximum MHS points carried equals the # of engines x 5
Engine Size B (hull sizes 5-14):	Maximum MHS points carried equals the # of engines x 20
Engine Size C (hull sizes 15-20):	Maximum MHS points carried equals the # of engines x 25

Current UPF and Sathar designs have yet to even approach these theoretical design limits; such advanced engines will likely take decades to design, test and bring to market. It is possible that races not yet encountered by the UPF may have such advanced engines, but (perhaps fortunately) none have yet been discovered.

NOTE: The only race to approach the above theoretical design limits is the Zuraqqor, whose Battlecruisers haul far more equipment for their size than equivalent UPF and Sathar ships; mercifully, Zuraqqor battlecruisers are few in number. The efficiency of Zuraqqor starship designs is top secret and known only to a few UPF admirals and military planners; likewise, only the upper clan leadership of

the Sathar are aware of the Zuraqqor technological lead in starship design.

MHS Sizes for Ships' Equipment and Vehicles

Although Knighthawks listed MHS sizes for most military equipment (weapons and defenses), it omitted MHS sizes for fighters (when carried by an assault carrier) and for non-military equipment. Equipment listed in boldface type is new and detailed in Appendix 2: New Equipment. Below are the MHS sizes for these systems:

Communication and Detection Equipment**	MHS
Decoy (launcher)	5
Agricultural Equipment**	MHS
Solar Collectors (when stored internally)	1
Emergency Equipment**	MHS
Escape Pod(a maximum of 1 per HS point can be mounted per KH)	0
Lifeboat	5
Transport Equipment**	MHS
Cargo (one MHS Point)	1
Docking Collar / Substation (HS 1)	3
Docking Collar / Substation (HS 2)	5
Military Equipment	MHS
HS 1 Fighter	5
HS 2 Military Shuttle***	6
HS 3 Scout Ship***	10
Exploration / Research Equipment**	MHS
Atmoprobe	2
Landing Drone	3
Laboratory	5
Remote Probe	3
Mining Equipment**	MHS
Digger Shuttle (HS 2)	4
Space Vehicles**	MHS
OPL(Orbital Processing Lab)	14
MR (Mineral Refinery)	12
Launch, Small (4 passenger)	2
(0 if mounted on a hatch instead of internally)	
Launch, Large (10 passenger)	4
(0 if mounted on a hatch instead of internally)	
Workpod	2
(0 if mounted on a hatch instead of internally)	

****NOTE:** Civilian equipment is much less demanding than military equipment; therefore, when calculating the total MHS points carried by a ship, divide the total MHS points of civilian equipment by 2. For example, a HS 16 mining ship has loaded a Mineral Refinery (MHS 12) and a Digger Shuttle (MHS 4) on board totalling 16 MHS points; the 16 points are divided by 2 since they are civilian equipment, making their effective MHS 8 which the mining ship carries at no penalty to ADF / MR. See also the expanded design sequence notes below.

*****NOTE:** HS 2 military shuttles are those carried aboard assault transports, usually 1 shuttle per 100 troops carried by the ship. The HS 3 scout ship is based on the scout ships carried by the Sathar mother ship in module SFKH3: Face of The Enemy.

Revised MHS Ship Design Sequence

The revised design sequence is identical to the procedure outlined in the "Limits" section of the Knighthawk's rulebook under Optional Space Equipment (page 19), except that in Step 4, instead of subtracting 1 from the result of Step 3 in all cases, the efficiency rating of the ship is subtracted instead. When adding equipment to a ship, follow the steps as outlined below:

1. Add together the Minimum Hull Sizes of all weapons, defenses, and military ships carried (fighters, shuttles etc.). Then add together all non-military equipment and ships carried on the ship; then divide the total MHS points of the non-military equipment by 2. Now add the total military MHS points and the total non-military MHS points (remember, the total points of non-military systems are first divided by 2).

2. Divide the ship's hull size by 2. If this result is greater than the sum from step 1, the ship can carry the weapons and defenses with no reductions, regardless of its efficiency rating.

3. If the sum from step 1 is equal to or greater than the result from step 2, then the ship's interior space and performance may be affected depending on the ship's efficiency rating. Divide the sum from step 1 by one-half of the ship's hull size (found in step 2). Round fractions up.

4. Subtract the ship's efficiency rating (1 for civilian ships) from the result from step 3.

The final result, found in step 4, is the number of ADF and / or MR points that the ship loses, and the number of ship hull units that are filled by weapons, defenses, power units and targeting servos. These hull units are unavailable for other units.

EXAMPLES: (HS 3 civilian research ship)

Ish Birdt is outfitting a hull size 3 civilian scientific research starship (described in the Knighthawks rulebook, p. 6). He wants to install a reflective hull (MHS 1), an atmoprobe (MHS 2), a Laboratory (MHS 5), a Remote Probe (MHS 3), and 3 escape pods (MHS 0). These systems add up to 1 MHS point of military equipment (the reflective hull) and 10 MHS points of non-military equipment. The step by step calculations are as follows:

1. Sum of MHS:

A. Military subtotal: 1

B. Non-military subtotal: $(2+5+3+0+0+0)/2 = 5$

A. (1) + B. (5) = 6

2. One-half of Hull Size: $3 / 2 = 1.5$

3. Step 1 divided by step 2: $6 / 1.5 = 4$

4. Step 3 minus efficiency rating: $4 - 1 = 3$

The final total is 3. This means Ish's ship must lose 3 ADF or MR points. Since his ship is only HS3, all available space on board is occupied by the equipment he has installed; he cannot carry any cargo or passengers beyond the 4 to 6 crewmen it was designed for.

(HS 3 military assault scout)

Ish Birdt now successfully bids on an assault scout contract for Spacefleet. Per UPF specifications, he installs a reflective hull (MHS 1), an assault rocket launcher (MHS 1) with 4 assault rockets and a laser battery (MHS 3) in the HS 3 hull. These systems add up to a total MHS of 5 points.

1. Sum of MHS:

A. Military subtotal: 5

B. (no non-military equipment carried)

2. One-half of Hull Size: $3 / 2 = 1.5$

3. Step 1 divided by step 2: $5 / 1.5 = 3.3$ (rounded up to 4)

4. Step 3 minus efficiency rating: $4 - 5 = (1)$

Due to the assault scout's efficiency rating of 5, it loses no ADF or MR due to excessive weaponry and defenses. In fact, its efficiency is 1 point higher than step 3, so it adds 1 ADF for a rating of 5/4.

Building Non-Standard Ships

EXAMPLES: The Sathar Mother Ship (from SFKH 3)

Ish Birdt has acquired the plans of a captured Sathar mothership - an obsolete assault carrier now designed to carry scout ships. As per the plans, he wants to install 2 laser batteries (MHS 3 each), a reflective hull (MHS 1), a ICM launcher (MHS 5), 6 sets of grapples - 1 for each of the scout bays and two external moorings (MHS 5 each), and 4 bays for HS Sathar scout ships (HS 10 each) for a total of 82 MHS points. The hull Ish is using is a HS 15 military assault carrier much like the original. Per step 2, he divides the ship's HS by 1/2 and gets 7.5. Per step 3, he then divides the total MHS points (82) by 1/2 the ship's HS (7.5) and gets 11 (rounding up from 10.93). The assault carrier hull he is using has an efficiency of 10, so his ship must subtract either 1 ADF point or 1 MR point; also, 1 hull point is given over to the excess equipment. As per the Knighthawks rulebook (p. 8), Ish's new Sathar mother ship has a DCR of 65 and 75 hull points.

The Sathar Juggernaut (from "Day of the Juggernaut", DRAGON # 91)

While exploring a new star in his replica Sathar Mothership, Ish Birdt and his enterprising crew have been captured and put to work designing a new ship class, the Sathar Juggernaut. With the help of Zuraquor engineers, Ish creates the following design in an attempt to save his sorry hide. The obscenely large hull (HP 480, DCR 300) will mount a disruptor cannon (MHS 12), 8 laser batteries (MHS 3 each), 2 proton batteries (MHS 10 each), 4 electron batteries (MHS 6 each), 1 torpedo launcher (MHS 5) with 16 torpedoes, and 20 rocket batteries* (MHS 5). The Juggernaut's defenses include a reflective hull (MHS 1), an electron screen (MHS 10), a proton screen (MHS 12), a stasis screen (MHS 10), and an ICM launcher* with 24 ICM's (MHS 5). Not content with this monstrous armament, the fiendish Zuraquor designers add bays for 20 Scorpion fighters (HS 2 each,

bays MHS 6 each); although the Scorpions are fighters, they are HS 2 and therefore use bays similar to HS 2 military shuttles (hence MHS 6 each). Overall, the Juggernaut rates a monstrous 248 MHS points of armaments. Awed by this gigantic warship but prevented from even seeing the complete plans, Ish can estimate its size and number of engines. At an efficiency rating of 12, the Juggernaut must be an unbelievable HS 42.

Its design sequence is:

1. Sum of MHS:

A. Military subtotal: 248

B. (no non-military equipment carried)

2. One-half of Hull Size: $42 / 2 = 21$

3. Step 1 divided by step 2: $248 / 21 = 11.8$, rounded up to 12

At 12 MHS efficiency points per engine, the Juggernaut mounts a complement of 21 Type C engines - more than three UPF battleships combined! Extrapolating from UPF designs, the Juggernaut should average 30 meters long per HS point, making it 1,260 meters long - twice as long as the largest UPF battleships; at an average of 5 meters diameter per HS point, it is 210 meters in diameter. As Ish is dragged by Sathar guards onto a Sathar slave ship, he voices a silent prayer for the Spacefleet ships doomed to be crushed by the Juggernaut.

NOTE: Should it be necessary to calculate the cost of a non-civilian ship (ie. any ship with an efficiency greater than 1), multiply the normal cost of BOTH the hull AND the engines by the efficiency rating. Thus a HS 5 "Nova" class yacht (efficiency 4), with 3 class B atomic engines, built at a Class I Construction Center would cost:

HS 4 x 50,000 Cr = 200,000 Cr + 3 Size B atomic engines x 300,000 Cr (per KH, p. 61) = 900,000 Cr = Subtotal 1,100,000 Cr x Efficiency Rating 4 = Total 4,400,000 Cr

It now becomes obvious why (besides UPF military secrecy laws) non-civilian hulls are only built by the wealthiest individuals and megacorps. Unless you are running a military campaign, PC's should be restricted to civilian hulls and the normal customization rules found in the Knighthawks rulebook on page 22.

Appendix 1:

Efficiency Ratings of Existing Ship Designs					
Ship (type)	Hull Size	MHS Point Subtotals Defenses*	MHS Point Subtotals Weapons*	Total MHS Points	Efficiency Rating**
Warships					
Fighter	1	1	1	2	4
Assault Scout	3	1	4	5	5**
Frigate	5	10	18	28	13**
Destroyer	6	10	24	34	12
Minelayer	7	6	20	26	5**
Light Cruiser	12-14	26	41	67	11-9**
Heavy Cruiser	16-18	38	51	89	11-9**
Assault Carrier****	14-17	10	18	28	4-5****
Battleship	20	38	60	98	10
Yachts***					
Rim Song class	3	1	3	4	2**
Imp class	4	1	4	5	2**
Nova class	5	1	13	14	4**
Astro-Blaster III class	6	6	9	15	3**
Nebula class	7	5	13	18	6
Belvedere class	9	6	13	19	5
Privateers***					
Thruster class	2	1	1	2	3**
Lightspeed Lady class	4	5	4	9	5
Moonbright Stinger class	9	6	18	24	5**
Rollo's Revenge class	10	6	24	30	6
Condor class	13	16	33	49	8
From module KH0					
Pirate Corvette	4	5	8	13	5**
From module SFKH3					
Sathar Scout Ship	3	1	0	1	(0)
From "The Zuraquor Strike Back!", DRAGON #95					
Zuraquor Fighter	2	1	4	5	7
Battlecruiser, Class D	9	10	24	34	7**
Battlecruiser, Class C	11	20	34	54	8**
Battlecruiser, Class B	13	32	51	83	11**
Battlecruiser, Class A***	15	42	58	100	13**

*Per the KH tactical operations manual, assault rockets, rocket batteries and torpdeoes can only fire once per turn; therefore, any ships with these weapons are assumed to mount a single launcher with multiple shots / ammo (the ammo contributes nothing in terms of MHS penalties - see KH, pp.18-19). Similarly, defensive systems such as masking screens and ICM's only count as a single launcher towards MHS limits.

**If a ship's efficiency rating is greater than the result of step 3 of the ship design sequence, the ship may add the overage to its ADF or MR. Certain military ships (such as minelayers and cruisers) are slower than an unarmed civilian ship of the same size; this is because their hulls and engines are not efficient enough to mount their armaments without penalty.

***The armament and defense statistics are the "official" ones listed in the article "Yachts and Privateers Return" (DRAGON # 88) by Gouglas Niles.

****Figures in the table do not include fighters carried by the carrier. Use the table below as a guideline for the true efficiencies of Assault Carriers:

Carrier Hull Size	# HS 1 Fighters Carried (at 5 MHS points each)	Weapon / Defense MHS Point Subtotal (from above table)	Total MHS	Efficiency Points Rating
14	6 (30 MHS Points)	28	58	9
15	8 (40 MHS Points)	28	68	10
16	10 (50 MHS Points)	28	78	10
17	12 (60 MHS Points)	28	88	11
Zuraaquor Battle Cruiser, Type A / HS 15	0-5 HS 2 Fighters (@8 Points each)	100	100-140	14-19

APPENDIX 2: NEW STARSHIP EQUIPMENT

Docking Collars:

Docking collars are used on larger ships to attach themselves (temporarily or permanently) to other ships, forming a secure bridge between the pair. Collars are similar to small ships, cylindrical (or, rarely, spherical) in shape; they can be built either as HS 1 or HS 2.

A docking collar hull (of either HS size) has 4 hatches, 1 on either end and 2 located midway along its length. The cost of a docking collar hull is equivalent to the price of a ship hull of identical size at a Class I construction center (ie. 50,000 Cr times the HS of the docking collar). This price is the same regardless of the Class of the construction center where the collar is actually built, due to the lack of drives, nav systems, etc. on the collar hull.

Docking collars can install Computers, Life Support Systems, Communication and Detection Equipment, Emergency Equipment as can normal ships; no other Knighthawks equipment besides Space Vehicles (see below) can be mounted. Due to their design, docking collars mount Space Vehicles as follows:

HS 1 Docking Collar: These can mount up to a single small launch (4 man) on one end hatch, and 2 escape pods or workpods on its mid-hull hatches. The remaining end hatch must be kept free to attach the collar to the mother ship.

HS 2 Docking Collar: These can mount up to a single large launch (10 man) or lifeboat on one end hatch, and 2 escape pods, small launches or work pods on its mid-hull hatches.

Substations:

Docking collars can also be detached to serve as independent "substations". Such substations are typically used for scientific research or as military listening posts. Substations are roughly equivalent in size and capabilities to the American Skylab or Russian Mir space stations, and typically house 2 crew per hull size point.

Substations are identical to docking collars in size and overall design, but cost more since they are intended for long-term habitation by their crews independent of the mother ship. A substation version of a docking collar costs the same as an identical ship hull built at the respective Construction Center. Use of a docking collar as a substation requires the installation of Life Support Systems, Astrogation Equipment (to guide other vessels in and track the substation's position), Computer Programs, and Communications and Detection Equipment as if the substation were a system ship of identical size. Substations have no engines but do mount small ion maneuver thrusters; these thrusters can maintain the substation's orbit for up to one year before needing refueling. Substations can mount Space Vehicles as do typical docking collars (see above).

A substation designed for scientific research mounts instruments with long-term data collection abilities similar to a Laboratory (as per Knighthawks, page 22); the instruments cost as much as a normal Laboratory (100,000 Cr). A substation's instruments can only collect atmospheric and geological data from a nearby planet, moon or asteroid. They confer a bonus equal to a normal Laboratory's (90% + 1% per level of success); however, data collection and analysis (ie. time required to use the appropriate skill) takes 10

times as long to complete as a similar task / skill use would require if the character was on the planet or moon itself.

Ag Ships:
Ag ships require 2 collectors per HS point



Since substations have no engines of their own, they must rely on other systems to provide power. Although compact nuclear generators (cost as per generator, Star Frontiers: Alpha Dawn, pages 41 and 47) can be installed, they are unpopular since any accidental leakage will force the crew to abandon the substation. More commonly used are solar collectors similar to those found on agricultural ships. Solar collectors are stored by the mother ship while enroute to the substation's destination, then mounted on the substation when it is deployed in orbit. While stored on the mother ship, the solar collectors count as 1 MHS point of cargo per collector. Once deployed on the substation, each collector generates SEU's as if it was a standard type 1 generator (see SF:AD, page 41); for example, a single collector generates 500 SEU's / hour, while 4 collectors would generate 2,000 SEU's / hour. A substation can mount up to 2 solar collectors per point of hull size.

Solar Collectors:

Solar Collectors (listed in the Knighthawks rulebook Equipment List, page 62) are required on ag ships, substations (see description above under Docking Collars) and standard stations (described in the Knighthawks rulebook, pages 4-5 and 8). Collector panels provide auxiliary power for ships and large stations, and main power for substations. Below are the number of solar collectors required for various ships and stations:

Standard Stations	
Agriculture and Docking Stations	These stations require 10 collectors per point of Station Type (size)
Commerce and Recreation / Trading Stations	These stations require 5 collectors per point of Station Type (size)
Military (armed / fortified / fortress) Stations	These stations require 2 collectors per MHS point of armament.

Substations:

Substations require 1 collector per point of HS; each collector generates as much power for the station as a SF:AD type 1 generator. At least one functioning collector per 10 crewmen is required to maintain minimal life support.

Solar Sails in Star Frontiers

By Andy Campbell

Solar sails fall into the category of "niche technologies" on the Frontier. That is, they are extremely useful but limited in their applications. The advantages of sails are that they are cheap and require no fuel; they are also fairly easy to maintain, and are the only drives potentially capable of more than 1 ADF that can be built at Class III Construction Centers. Their disadvantages, however, are equally great: they are only useful in the inner regions of solar systems, and they are easily detectable by radar. Thus, solar sails are common but only in a narrow range of applications - civilian freighters, passenger liners and research system ships. They will never be found as military, courier or pirate craft.

Knighthawks Performance Characteristics

A solar sail equipped ship's ADF is $[1 \times 1/(\text{ship's distance from star in AU})^2]$. Examples are given below of ADF's at typical system orbits:

Distance from System's Star	Example Planetary Orbits*	ADF**
0.4 AU	Mercury	7
0.5 AU	Snowball (Mhemne homeworld)	4
0.7-0.8	Venus, Inner Reach, Gollywog (Clarion), Liberty system's asteroid belt	2
1 AU	Earth, Outer Reach / Dramune	1
1.5 AU	Mars	1 / 3 turns (about 2 / hr)
2.2 AU	Lost Reach / Dramune, White Light system's asteroid belt	1 / 5 turns (about 1 / 50 minutes)
5 AU	Jupiter	1 / 25 turns (about 1/4 hrs 10 minutes)
10 AU	Saturn	1 / 100 turns (about 1 / 16 hrs 40

20 AU	Uranus	minutes) 1 / 400 turns (about 1 / 66 hours, 40 minutes)
30 AU	Neptune	1 / 909 turns (about 1 / 151 hrs 30 minutes)
40 AU	Pluto	1 / 1600 turns (about 1 / 267 hours)

* Sample orbits greater than 1 AU are rounded to the nearest AU for simplicity's sake; orbits less than 1 AU are rounded to the nearest 0.1 AU. 1 AU (Astronomical Unit) equals roughly 149.7 million km.

** ADF ratings are rounded to the next lowest number (ie. 2.5 ADF = 2)

No matter what the size of the ship, the size of the sail or the distance to the nearest star, a solar sail-propelled ship will always have a MR of 1; the MR is produced by altering the size and angle of the sail combined with high-efficiency chemical attitude jets.

Solar sails are too thin to generate power for the ship, which must carry an independent power supply (usually a small nuclear plant or a solar array. Since their power plants generate minimal energy emissions, solar sail equipped ships are invisible to energy sensors. Due to the huge area of the sails when they are deployed, a sail-driven ship can be detected by radar at twice the normal distance (600,000 km); if the sails are reeled in and stowed, the ship will be detected by radar at the normal range (300,000 km). Deploying and reeling in a sail requires 1 turn per 10,000 square meters of sail area.

Size and Cost of Solar Sails

The sizes and costs of solar sail drives are as follows:

Hull Size (Engine Class)	Sail Size
HS 1-4 (Class A)	1000 square meters (1 square km) / HS point
HS 5-14 (Class B)	10,000 square meters (10 square km) / HS point
HS 15-20 (Class C)	100,000 square meters (100 square km) / HS point

NOTE: If a ship is equipped with a sail of the next higher engine class (ie. a HS 3 ship is equipped with a 30,000 square meter sail), the sail's ADF performance will increase by a factor of two; this is rarely done, especially on larger ships, due to the prohibitively large sails required.

COST			
Hull Size (Engine Class)	Class I Center	Class II Center	Class III Center
HS 1-4 (Class A)	10 Cr / square meter	12 Cr / square meter	15 Cr / square meter
HS 5-14 (Class B)	5 Cr / square meter	6 Cr / square meter	8 Cr / square meter
HS 15-20 (Class C)	1 Cr / square meter	1.2 Cr / square meter	2 Cr / square meter

Sail Construction, Mounting and Stowage

Solar sails are made possible by advanced materials technology, allowing for extremely thin and reflective films and superstrong support cables. Primitive sails were built using ultrathin thin mylar for the sails and high-strength copper alloys for the support cables. Modern sails are composed of heat-resistant boron only a few hundred atoms thick, manufactured under vacuum conditions on orbital stations; the thin support cables are filaments of industrial diamond extruded in orbital factories.

Solar sails are the only drive that can be mounted in addition to traditional engines. Where traditional engines are mounted at the back of a ship's hull, sails are mounted at the front end, towing the ship along behind. It is not uncommon for a ship to mount a sail as a back-up to its regular engines for emergencies; this option is especially popular on deep space research vessels and on passenger liners.

Solar sails are composed of molecules-thick (in advanced sails, even atoms-thick) reflective materials and thus add comparatively little mass to a ship. This allows them to be stowed in compartments mounted on the outer hull of a ship or in internal cargo bays. If sails are stowed internally, they occupy 2 HS points per Size Class of the sail; external stowage uses only 1 HS point per Size Class of the Sail.



Space Stations: Islands in the Sky

By Andy Campbell

Overview

Space stations are one of the many contradictions of Frontier life - familiar homes to spacers and those who frequently travel to other systems; they remain exotic locations known only through holoivid programs to many planetbound citizens. Many smaller worlds do not even have a station-class facility in orbit. Nevertheless, as Zebulon's Guide FY 111 edition went to press over 40 stations wheeled serenely above the worlds of the Frontier. Though their populations are insignificant by planetary standards, the inhabitants of Frontier stations have a disproportionate impact on the UPF's economy and its defense in time of war. This datafile is intended to familiarize the average citizen with these orbital colonies - how they are run, what role they play in the economy of the Frontier, and what life is like on them both for permanent residents and travelers.

Where They Are: Station Orbits

Most space stations are built in orbit around a planet, though some have been constructed in orbit around a moon or a system's star. Stations in orbit around a planet will be built in one of two locations - either in geosynchronous orbit (where the station will remain above a single point on a planet's surface), or at a Lagrange point (a stable orbital point around a planet with one or more moons). A station built in geosynchronous orbit will usually be positioned above the planet's busiest surface starport. Both orbit types are stable orbits, enabling the station to remain in place without having to use spacecraft tugs to correct drift in its orbit.

Stations which are not built in planetary orbit are built where they are for a reason - most common are agricultural and power stations, which are built in solar orbits close to the system's star to take advantage of the more intense sunlight for crop growth and power generation. Synthcorp and the AIPS operate most of the stations in solar orbits. A few smaller stations have been built in orbit around moons in recent decades, but proved unprofitable and are no longer in service.

Rumors have surfaced in recent years of stations secretly built in distant solar orbits (500 million or more km from their star) by the UPF and the larger megacorps. These stations have been variously described as top-secret research facilities, emergency habitats (to house UPF citizens or troops in the event of another major war), high-security prisons, and colonies for newly discovered alien races which the builders wish to conceal from the public. Thus far none of the rumors has been proven, but these "shadow stations" are favorite topics for Frontier holodramas and conspiracy groups.

What's Up There?

Space Station Construction

Many citizens use the term "space station" fairly loosely when discussing facilities built in orbit; if a facility is any larger than a satellite, they call it a space station. However, the term "space station" actually refers to a particular class of large space settlement - a fact few planetside citizens realize.

A space station is a facility which is 200 meters or greater in diameter, maintains a surface gravity on its rim by rotation, has no propulsion system, and maintains a permanent population. Any space facility which does not meet all of these criteria is properly called a "workshack", a term which includes all the facilities, large and small, which swarm the skies over the planets of the Frontier. While workshacks fill a valuable niche conducting research, manufacturing and other activities, they do not count as full-fledged stations; few workshacks maintain gravity onboard so as to take advantage of the unique possibilities of low- and zero-gee. Space stations, on the other hand, serve as hubs of commerce, housing large populations and usually providing their own food and life support needs.

The universal station design adopted on the Frontier is a ring or torus rotated to provide gravity at its rim; spokes connect the torus to a central sphere. The torus section contains the station's housing and agricultural sectors, retail and office space, recreational areas, and maintenance decks. Individual decks vary in size from 5 meters in height (3 meters of space, with 2 meters of decking, ductwork, etc.) to as much as 20 or even 50 meters height; examples of large open decks include main promenades, sports or entertainment arenas and large industrial or warehouse facilities. Shielding between 1 and 5

meters thick lines the outside rim of the torus, protecting the station from impacts and radiation; the inner rim of the torus is completely lined with windows, providing a view of the whole station and allowing natural sunlight to be angled in to the torus by large mirrors. The spokes connecting the torus to the central sphere or core include elevators, connecting tubes, and (in larger stations) low-gee office and manufacturing space. The central sphere houses the station's administrative offices, security and defense facilities, major medical facilities, warehouse space, and zero-gee recreational areas; de-spin connectors link the sphere to docking modules (usually "north" of the core - see appendix) and to zero-gee manufacturing modules, heat radiators, and solar panel assemblies (usually "south" of the core).

Large stations can incorporate multiple toruses linked by their cores along a common axis of rotation. These stations often have specialized toruses - one housing retail shops, one housing residential units and one housing agricultural / farming areas for instance. Such a large station will also have a high-speed elevator system running along the length of its central cores, providing high-speed access to the different toruses. These giant stations are the pride of the Frontier, economic powerhouses with populations in the tens (even hundreds) of thousands.

Space stations represent a huge investment for a government or megacorp, which explains why they are somewhat uncommon despite their benefits for the owner and planet below. A single large station masses as much as hundreds of thousands or even millions of tons of material, all of which must be launched into orbit or towed from a moon or asteroid belt; once in operation, a station requires constant maintenance to remain a safe and profitable home for its population. The construction of space stations are among the greatest engineering achievements of the Federation.

Who's In Charge?

Space Station Ownership

Space stations on the Frontier are unique settlements. Unlike planets, they do not usually have an independent government; unlike moon colonies, their territory has been built from scratch - a massive investment which must be paid back before any thoughts of independence can be considered. Stations do not have independent representatives in the UPF government like moons or planets either.

Though station managers and representatives may be called to testify at UPF government proceedings, no station maintains any sort of permanent post or embassy in the UPF government.

The vast majority of stations are built and owned by either a planetary government or megacorporation, who administer the station as their territory. An exception to this rule are the huge UPF Space Fortresses, built by the UPF Spacefleet for the defense of the Frontier; these stations answer only to their commanding officer in the Fleet, and the latter to the UPF government.

**Earning a Living:
Commerce and Industry on Space Stations**

The three UPF classifications of stations are useful in understanding how stations and their inhabitants earn their livings. These classifications are military stations, trading stations, rest and relaxation stations, and docking stations.

Directions on a Space Station

- Above Core Module:** "North"
- Below Core Module:** "South"
- Clockwise:** "East"
- Counterclockwise:** "West"
- Towards Core:** "Up" or "Topside"
- Towards Rim:** "Down" or "Below Decks"

Table 1: Stations - Game Statistics

Hull Points	
	40 hull points / point of size (ie. size 4 equals base 160 hull points)
	+0 hull points if Armed (example: HP 80 at Size 2)
	+20 hull points if Fortified (example: HP 140 at Size 3)
	+60 hull points if a UPF Space Fortress (example: HP 300 at Size 6)
DCR	
	25 points / point of size (ie. Size 4 equals base DCR 100)
	+25 points if Armed (example: DCR 75 at Size 2)
	+25 points if Fortified (example: DCR 100 at Size 3)
	+50 points if a UPF Space Fortress (example: DCR 200 at Size 6)
Armament (from KnightHawks)	
	Armed Station Weapons: LB, RB (x 6) Defenses: RH, MS (x 2), ICM (x 6)
	Fortified Station Weapons: LB (x 2), RB (x 8) Defenses: RH, MS (x 2), ICM (x 10)
	Space Fortress Weapons: LB (x 3), EB, PB, RB (x 12) Defenses: RH, MS (x 3), ES, PS, ICM (x 20)
Airdock Space (Size 6 Docking Stations only)	
	Class I (2 - Gran Quivera, Triad): 140 hull points
	Class II (3 - Hentz, Minotaur, Terledrom): 50 hull points
	Class III (4 - Gollywog, Outer Reach, Pale, Rupert's Hole): 20 hull points
Vehicles	
	1d10 launches per point of station size
	1d10 work pods per point of station size

Table 2: Standard Station Dimensions

Cross-Sectional Dimensions of Components

Size Class	Total Station Diameter (Class x 200m)	Core Diameter (Class x 40m)	Length/Diameter of Spokes (6 total)	Diameter of Torus (Class x 40 m)	RPM	Gravity Produced at Core Rim	Gravity Produced at Outer Rim*
1	200m	40m	40/10m	40m	3	0.25	1
2	400m	80m	80/20m	80m	2.5	0.25	1
3	600m	120m	120/30m	120m	1.75	0.25	1
4	800m	160m	160/40m	160m	1.5	0.25	1
5	1000m	200m	200/50m	200m	1.4	0.25	1
6	1200m	240m	240/60m	240m	1.25	0.25	1
NASA**	1790m	130m	700/15m	130m	1	.1	

*Since the outer torus of the station is composed of multiple decks, the effective gravity felt as one moves towards the core and away from the rim will decrease. Actual gravity at the outer rim will decrease from about 1G at the rim to as low as 0.8 G on the uppermost decks of the torus. Also note that as one travels in an elevator from the core to the rim / torus, and vice versa, perceived gravity will change as well. A being riding an elevator "up" into the core will gradually feel themselves become lighter; conversely, a being riding the elevator "down" into the torus decks will feel progressively heavier as they approach the torus.

**The NASA listing is based on a toroidal station design (the "Stanford Torus") developed by NASA in the 1970's. The study was published by NASA as *Space Settlements: A Design Study in 1977*.

Table 3: Projected Areas and Populations

Size Class	Major Radius (R)**	Minor Radius (r)**	Projected Area (Ap)**	Population*		
				(at 50m ² / person)	(at 75 m ² / person)	(at 175 m ² / person)
1	80 m	20 m	20,106 m ²	402	268	115
2	160 m	40 m	80,425 m ²	1,609	1,072	460
3	240 m	60 m	180,956 m ²	3,619	2,413	1,034
4	320 m	80 m	321,699 m ²	6,434	4,289	1,838
5	400 m	100 m	502,655 m ²	10,053	6,702	2,872
6	480 m	120 m	723,823 m ²	14,477	9,650	4,136
NASA**	830 m	65 m	677,956 m ²	13,559	9,039	3,874

* The 1977 NASA study "Space Settlements" used 67 m² / person as the design guideline; this sum did not include agricultural, industrial and public space which was separately allowed for and the 67 m² assumes such other space is already allotted. In other words, 67 m² takes into account that adequate space for the previously mentioned activities is present as well. If the station has no agricultural or industrial zones, the above population figures could be doubled without overcrowding; however, the station would then be completely dependent on outside sources for food, life support and goods. For comparison, Manhattan Borough, NYC had 38 m² / person at that time; San Francisco, CA came in at 164 m² / person, and Boston, MA rated 185 m² / person.

** The Major Radius is the distance from the center point of the station to the center point of the torus. The Minor Radius is the radius of the torus.

The Projected Area is a ribbon like strip lying along the midline of the ring, with the "ribbon" itself perpendicular to the spokes. Note that population figures are based on the equivalent of a single deck being used for residential space on the station; other decks (from 2 to over 20 depending on the station) typically house life support, agricultural, maintenance, administrative, industrial, retail / office, educational and recreational facilities. Larger stations (size 4 hulls and up) will have as many as 10 residential decks of varying sizes and will house proportionally larger populations.



FRONTIER FICTION

By Eric Johnson

Author's Note: This is a sequel to the story "Bug Hunt" that appeared in the Star Frontiersman e-zine issue 17.

Hunger of the Shadow

I. Respite

Two figures stood on top of a dune scanning their surroundings. The heat waves rising off of the sand shimmered about them. Bladen Rand, a human from the Cassidine system, scanned the desolate landscape with magnigoggles. His appearance was haggard. Bladen's short hair was drenched in sweat and his lips were blackened from a lack of water. His dust covered uniform denoted that he was a member of the United Planetary Federation military. Bladen licked his lips as he held out the magnigoggles to his inhuman companion.

"See if you can see anything, Gruk," said Bladen.

Gruk, a yazirian from the planet Hargut, took the device from the human. Because he was a yazirian, his eyes were light sensitive. He wore sungoggles so he wasn't blinded in the, what other races considered normal, light. A slight breeze caused the thick brown hair of Gruk's mane and collar to move as his four knuckled fingers worked the adjustments on the magnigoggles. The breeze was not strong enough to billow Gruk's patagia or to provide any relief from the sweltering heat.

Bladen took his canteen from his belt. He shook it and made a sour face. There wasn't much left, an all too familiar situation for them on this arid dust ball. His tongue felt like an old dried piece of leather. He looked over at the big yazirian.

Gruk's tongue hung out of his muzzled face while he panted. It was a futile effort to cool himself. Yazirians did not possess sweat glands like humans and

dralasites. They were native to temperate climates, not the scorching desert heat.

The gas giant, of which this moon orbited, dominated the sky day or night. It was the system's prime jovian. Bladen had imagined that the planet was the huge unblinking eye of some dark and twisted god.

"It looks like thirst might get us yet," stated Bladen.

The yazirian did not respond. He was focused on searching the sandy waste of this moon for a means of continuing his existence. They had truly been on their own in this hellish wasteland. He and the human had survived in this place for several weeks since the klikks had shot down their ship the "Specter". The rest of the crew did not live through the crash.

Gruk estimated that they had been here between three and four weeks. In the time since, they had been hounded by the klikks, explored a sand choked ruin, witnessed things that could not be explained rationally, and stole a klikk armored hovercraft. They had been on foot for about a day and a half since the appropriated vehicle had stopped working. All of their attempts to revive the alien contraption had ended in failure.

Gruk thought that the human was right. Despite his fierce and savage will to survive, the yazirian knew that neither of them would make it another forty-eight hours before the delirium that comes from dehydration would set in. It would be a slow lingering death from that point on. They had no beam weapons so they couldn't do themselves in that way. If Bladen went mad first, Gruk would make his passing quick and merciful. He hoped the human would do the same for him.

Gruk stopped in his slow and deliberate scan of the horizon. He had seen something then he did not. He waited. It fluttered back into view and then it was gone just as fast. It looked like a domed city with an outer defensive wall. But how could that be? Cities just don't disappear. Maybe the madness was setting in on him now.

"Maneless, look on the horizon over there," said Gruk pointing in the direction of the flickering city. It was somewhere near where the gas giant's edge met with this moon's horizon.

Bladen took up the goggles again and peered through the blistering heat. He saw nothing but the shimmering waves that were slowly baking him and his companion.

"Well dog face, I think the heat has fi-, "the cassidian stiffened. He saw the city in the distance strobe in and out of view. He closed his eyes and shook his head. He refocused and saw the phantom again, and again it disappeared.

"What the scéf!" exclaimed the human.

"I thought dehydration was getting me," said Gruk.

"I hope the gods aren't playing with us. Let's go," said Bladen.

"Hopefully this one isn't haunted by devils," said Gruk.

"I hear you brother. I hear you."

Bladen placed the magnigoggles back into their case. They set out across the desolate landscape.

Both moved with a new purpose. The chance of finding water was consuming their thoughts more and more. Their endurance when walking in the day's heat had grown substantially since their unexpected arrival. They were becoming acclimated to their current environment. Without their ability to adapt, the two soldiers would have perished weeks ago. Despite this, both the human and yazirian were nearing the verge of collapse.

Gruk scratched at the edge of the symbiotic life form that was attached to the left side of his face. Bladen had one also. The amorphous creatures had been attached to them during their brief capture by the klikks. The thing had bonded to his skin and inner ear. It was some kind of bio-technological translation device. Like a poly-vox, it allowed the wearer to understand unfamiliar spoken languages. The pair dubbed them "translators."

"I'll be glad when we get back home and the doctors get these things off of us," said Gruk.

"I just want to get back home," was the reply. Bladen was thinking of his family back on Ruppert's Hole. He'd trade or give up just about anything to see them again or just to let them know that he was still alive and loved them.

Bladen didn't like to think about the symbiotes on them. It reminded him of the nameless horror that was contained in the ruined city they had sought refuge in a few weeks ago. Something from the bowels of Hades had risen up to slay their captors. The thing must have mistakenly thought that the human and yazirian were dead. They had escaped with their lives and the klikk's armored hovercraft.

The two had made their way back to the wreckage of the Specter. A few power cells and a vibrosword were the only things salvageable. Bladen had the sword while Gruk held his zamra. They would have preferred laser weapons but were thankful to have what they did.

The zamra was a yazirian ceremonial dueling weapon commonly carried by warriors. The sharp-edge disk was about ten centimeters in diameter. It was commonly thrown. However, a zamra was just as deadly when used in close quarters combat.

The soldiers were able to avoid any further encounters with the klikks. The captured hovercraft had given them the mobility that they had needed to stay out of harm's way. Now that the APC was no longer functional, it was only a matter of time before the mantis warriors hunted them down.

The pair decided that it was no mirage that they were seeing as they drew closer to their destination. The entire city would be visible and then wink out of existence at irregular intervals. There had to be some kind of stealth screen technology in use. This was something that was beyond anything that the UPF had. It was their first indication that some beings may actually inhabit this sand strewn satellite.

The night cycle was a few hours away when they reached the twenty meter high perimeter wall of the place. It seemed to be of similar construction to the only other city that they had seen. The scale was massive and breathtaking. It was the same greenish stone as the other city. Gruk and Bladen looked at each other. A sense of foreboding settled over the pair. They followed the wall to what appeared to be

an airlock. Gruk examined the immediate area while Bladen went to work on the control panel.

Gruk could not find any exterior cameras. There weren't any guards to challenge them from atop the battlements. The walls were decorated in the familiar glyph writing present in the other ruins. The airlock was made of metal scoured by sand carried aloft by countless storms. The yazirian kept his zamra ready for the first sign of trouble.

Bladen looked at the control panel. There were buttons and what appeared to be some kind of palm scanner. There was an unfamiliar script on each of the keys. It was something not present in the other city. The palm scanner was for a four fingered hand similar to his in size. One of the knots in his stomach untied itself. He pulled out his survival knife and went to work on the controls. The faceplate came off with surprising ease. The plate was suspended by a series of wires that ran into the compartment behind opened panel. When the door slid open a draft of air wafted out. It was cool, air conditioning!

The two looked at each other. With simultaneous nods, they went in weapons at the ready. Inside the door was a large enclosed room. A portal on the opposite wall marked the only other exit. The place was empty save for a body propped up in a sitting position in the far right corner.

The human and yazirian went over to the body for a closer look. It was wearing some sort of body armor. The armor was a tangerine-like color. Based on the thickness of the plates Gruk guessed it was meant for light combat.

Bladen could tell by the design that the wearer was by pedal standing a little over two meters tall. The ends of its booted feet were splayed into two halves where the toes on a human would have been. He thought the being must have two large toes. It also possessed an elongated heel giving each foot a triangular look.

A sheath housing a long blade hung from a belt. The being's two arms hung limply at its sides. Its helmeted head was cocked to the left and hung forward. The helmet was unusual in the fact that instead of the usual ovoid shape, it looked trapezoidal. The short edge of the trapezoid was where, Gruk assumed, the face would be.

There were also wires running from the headgear to a small black object. The object was rectangular in shape about twelve by seven centimeters. It was around one centimeter thick. A light on its edge flashed very slowly.

The armored figure didn't move.

"Do you think its dead?" asked Bladen.

Gruk gave the armored figure's foot a kick. Bladen was ready to jump back and give the thing room. There was no reaction. He did it again, still no reaction.

"I think so," answered the yazirian. "It hasn't been too long though. Rigger's not set in."

"Do you think being dead at your post is dereliction of duty?" asked Bladen with a wry smile as he pulled his right forearm across his forehead to wipe away the sweat.

A humored grunt was his reply.

"Let's see if we can find some water. Right now I could care less if the rest of the city is filled with corpses like this one," stated the human.

Bladen went to work on the other door's control panel. This door was proving far more difficult to breach than the outer door. The clang of metal on metal pulled his attention away from the task at hand.

"Gods of Yaz!" exclaimed Gruk from between clenched teeth. Bladen saw his companion engaged in melee with the supposed corpse.

The yazirian had countered the guard's downwards blow by deflecting the incoming blade to his left. This maneuver allowed Gruk to bring his zamra around in a savage backhand. The disk found the seam between the armored shoulders and helmet.

The battle disk sheared through flesh and bone. There was a loud clack when Gruk's gauntlet impacted with the alien's armored head. The helmet remained on as the head spun in the air like a pinwheel of blood. It clattered on the floor; the body staggered drunkenly, an arch of greenish-yellow blood jetted from the trunk; then it fell heavily.

Gruk looked around, panting, ready for the next challenger.

"I thought the nugger was dead!" exclaimed Bladen.

"Well he is now anyway," said Gruk. He smiled the smile that he always had after defeating an opponent. "So much for a warm welcome."

"I hope they've heard of self-defense."

Bladen returned his attention to the door. Gruk picked up the small device that had been attached to the guard's helmet. He smelled it and then stuffed the thing into a cargo pocket.

The door opened. Bladen peered through the portal. The human was looking into a totally enclosed multi-level complex. Whoever lived here had not just taken up residence and incorporated their architecture and technology; they had totally enclosed the city. He glanced at the archways that gaped blankly from the green walls above them. He saw no hint of movement, heard no sound. It was a tomb.

"This place is giving me the creeps," said the yazirian who was now standing next to him.

"We'll go into one of those doors," Bladen said. "Surely we'll find something to drink and eat in *this* city."

"I just hope this isn't another abode of demons," restated the yazirian.

"You ain't the only one," said Bladen as he absentmindedly rubbed the translator.

Gruk got a chill up his spine. He glanced back at the headless corpse lying on the ground. He wanted to make sure it hadn't gotten back up.

Bladen stated, "I'll take point."

They moved with the practiced discipline of soldiers trying to ferret out an unseen enemy that they knew was there. The two stayed in the main hallway for some distance. They entered an open doorway, and found themselves in a wide chamber. The walls were hung with tapestries of a soft looking bluish material, worked in alien designs. Floor, walls and ceiling were of the green glassy stone. Strange furs and plush cushions were scattered about the floor.

Several doorways let into other rooms. They passed through, and traversed several chambers,

counterparts of the first. They saw no one. Gruk's muzzle wrinkled. He began to closely examine the furniture and accoutrements. The yazirian grunted suspiciously and scanned the room.

"What's wrong?" asked Bladen.

"I thought I smelled perfume in the air, so I checked the furniture. This couch is still warm from body heat," Gruk explained.

The place was disconcerting to both of the soldiers. The rooms were a mixture of the ancient green cyclopean stone with the more modern accessories of a technological society. The alien designs were brought together in such a way as to invoke a mild sense of vertigo. It was surreal and unnerving.

Some of the rooms that they passed by were dark. The pair avoided those. Other rooms were illuminated softly. The light fixtures were recessed and not readily visible. They investigated most of the illuminated rooms that they came across. In one such room, Gruk grabbed Bladen by the arm unexpectedly.

The human almost jumped out of his skin, "What the nug, dog face? I just about scefed myself."

"Look there," Gruk said pointing a four-knuckled finger.

"Jackpot," said Bladen a little too loudly for Gruk.

The human saw what appeared to be a dining table with food on it ready to serve. They looked around to make sure there was no one in the area.

"Let's dig in," said Bladen, his mouth was already watering.

"Wait maneless, it may be a trap or a set up to bring our guard down," cautioned the yazirian.

"Well at least I'll have a full belly," said the man as he took a seat.

Bladen grabbed what looked to be a drinking vessel and held it up to his nose. The color and mildly alcoholic smell were not repulsive, so he took a drink. It tasted so good to his parched mouth that he emptied the glass before continuing. The food was a mixture of unknown fruit and meats. He ate like a starving animal, quickly and barely chewing. Gruk gave

up his misgivings and joined in after watching his companion gorge himself on the alien food.

Hunger and thirst now sated, the two sat across from each other discussing their situation. It was evident that this place was populated. They felt confident that if needed, they could defend themselves with the weapons that they currently possessed. They needed to find better weapons as soon as they could. A full stomach and little rest were taking their toll on the pair. They began to feel sleepy.

"Let's see if they have a restroom in this place," said Bladen. "We both could use a wash and I need to add some water to the recyclers."

"I don't like this city. It has the taint of evil. We need to see if this place holds a way off this damnable moon," said Gruk.

"Roger that," replied the human.

"We need to be quick about it too. As soon as they discover our friend from earlier, they'll begin looking for us," said the yazirian.

Gruk's head suddenly turned to his right. He heard something approaching. He stood, zamra in hand. The yazirian's other hand extended one finger indicating the need for noise discipline. He faced a doorway. Gruk swiftly moved to the wall next to the threshold. He had his back flat against the tapestried wall with the zamra ready to strike whomever or whatever came through the doorway. Bladen drew his blade and joined him.

The chamber on the other side of the doorway was dark except for the light from their room that invaded through the open doorway. Gruk peaked around the corner. There was another doorway across from the one where he stood in a half crouch. In that far den, he could make out a foot, no, feet of one of the aliens. They sat upon a bed or couch. The feet seemed to be similar to those of a reptile but at the same time were similar to that of an avian. The being's legs stretched into the surrounding darkness.

Gruk saw no movement in those lower extremities. Was it dead? Was it like the guard from earlier, only appearing dead? Gruk heard the faint rustling sound again. It was coming from that room. Someone in there was stealthily moving about. His hackles went up. The yazirian pulled back fully as not to be seen.

Some primal instinct was warning him not to move. He looked at Bladen and motioned for silence. Gruk signed that there were two or more enemies beyond the arched doorways.

The pair waited several minutes before Gruk dared another look. The feet on the bed could no longer be seen. A small pool of the alien blood on the floor was partially illuminated. He waited and did not detect any further sounds.

Gruk felt the cold chill of fear coming over him. The list of things that the yazirian was afraid of was very short. However, it grew with each day that he spent on this desert moon. Foes of flesh and blood were viewed as challenges, but the primal, instinctual part of his brain was screaming at him that whatever had been in that room was not natural. He fought the urge to growl.

Bladen finally made the first move. He entered the intervening chamber and took up position on the left side of the doorway that led in to the far chamber. Gruk hesitantly followed. He stationed himself to the right of the doorway. Gruk peered in cautiously.

The blood was more of a smear than a pool. The rest of the room was similar in appearance to the others that they had seen. There was a dais-like bed, throw pillows, tapestries and nothing else. There was no sign of a body or of what else had been the room. Gruk's feeling of dread was growing.

Bladen saw another of the small rectangular black objects with wiring hanging from it. They were much shorter than those on the other one. The wires looked as though they had been melted through. He showed the device to Gruk. He found it hard to focus on the thing because the unnatural horror that permeated the place.

Gruk was ready to leave; damn the water, the supplies, the way off this rock, it was time to get as far away from here as possible. Better a clean death of withering in the desert than risking their souls in this place.

Somewhere back along the way that they came, Gruk heard a footfall. He motioned to Bladen. The two began stealthily checking behind the tapestries for another exit. They found one and quickly went through it despite their misgivings that this might be the path of whatever had just made off with the alien.

They made their way through the chamber and into another. Inside was one of the city's residents. It was thin with no body hair. Its skin was light brown in coloration. The head was an elongated flattened wedge with six eyes in two sets of three. It had two arms with four fingered hands. The fingers ended in thick claw-like nails. It was eyeing them almost in a disbelieving way.

The alien's eyes did not seem surprised or frightened. They seemed to have a faraway look like those of a drug addict. It possessed one of the black pad-like rectangles the wires ran to various points along its head. After a tense moment it spoke. The voice was raspy and asexual. A thin tongue became visible as its jaws worked. The translators on their heads tensed, relaxed, and grew warm.

"Who are you," it said.

Bladen responded but the being seemed puzzled and uncomprehending. It held up the black device and started tapping one of its claws on it.

It began talking to itself, something about having wandered into someone else's reality. It eyed them again.

"Thaxus' work, it has to be," it mumbled again. It worked its fingers furiously on the pad. The thing looked up again.

"How are these things still here?" it spoke. It stared at them for a moment.

"Whose avatars are you?" the alien questioned.

"What are you talking about?" asked Bladen. Again the alien looked at them uncomprehendingly. He could sense the creature's building frustration.

It walked up and started to pinch a prod both of them. Gruk tensed up, ready to defend himself if things got out of control. Bladen took the opportunity to get a closer look at the alien.

"You two are some of the most realistic work that I've seen. It has to be Thaxus. Yes, Thaxus," it convinced itself. "His mind's eye as always tended towards the ugly and horrible."

Gruk's eyes went wide and his muscles grew taut as though he was preparing to strike the stranger. Bladen

made a face and shook his head quickly back and forth, telling his companion that was not a good idea.

It stared for another few moments. "I guess I'm going to have to reboo-," it stopped, slack jawed. The far off look faded from its eyes. The alien was focused on something behind them.

Gruk and Bladen turned to look at what it was looking at. In another door way was...a dralasite! It had contorted its body into an odd non-humanoid shape, but it was definitely a dralasite.

The alien ran screaming from the room, "Xulthax, the shadow of death, has awakened! Run, fools, run!" In the creature's mad haste it hit the door jam and spun half around. It continued to scream as it fled. Gruk and Bladen hear the screaming suddenly cut short. They looked at each other and then to the dralasite.

The amorphous being was lying on the carpeted floor laughing hysterically. It was slowly assuming another shape. Gruk and Bladen felt a spark of hope at the sight of the little laughing blob.

Dralasites are one of the most populous races in the UPF also known as the "frontier." Like an amoeba, dralasites do not have any bones or hard body parts. Unlike an amoeba though, they are multi-cellular, intelligent, and quite fond of pranks and jokes.

Their gray skin is tough and has a rough texture. They are well muscled beneath their skin. This characteristic allows a dralasite to grow or sprout limbs as needed instead of having a fixed number. Veins and nerve bundles visibly run through a dralasite's skin. They meet at the two points that act as their eyes. The vein pattern gives them the illusion of being covered in spider webs.

"That never gets old," howled the dralasite still laughing at his prank.

"That was funny, but who in the nug are you?" asked the human.

"Just give me a minute," stated the giggling dralasite.

Gruk was starting to get antsy. He wanted to vacate the area. The shock of meeting a dralasite had not made him forget about the thing that left the bloody smear in the other room.

"We've got no time for this," stated the yazirian looking around. "Who are you and how did you get here?"

"The name's Akricit," he said. The dralasite now had a form the two were used to. It now had pear shaped torso with two arms. Three legs had sprouted in a tripod pattern. "I was marooned here by the crew of the ship that I was on."

"Marooned?" said Bladen. "How'd you get here in the first place?"

"Well, we void jumped of course."

"That's not what I meant. Out with it."

"Okay, okay, I was an engineer on the Jowanet, a merchant out of Homeworld. We were attacked by pirates and I was taken captive. When I refused to join with them, they marooned me here, wherever *here* is," Akricit explained. "I was beginning to think that I'd be stranded forever."

The dralasite examined the human and yazirian. His epidermis wrinkled, then he asked, "what about you two? Where's your ship? And what are those things on your heads?"

"I'm Bladen and my friend here is Gruk," he made a gesture to the yazirian. "We were on a reconnaissance mission when we were engaged by an unknown ship. We crashed on this moon. That was about three weeks ago."

Gruk took over, "These things were placed on us by some aliens that briefly had us captured. They are all dead now."

"How long have you been here?" asked Bladen.

"I lost track after the first two years."

"That creature was speaking about something called Xulthax. It was deathly afraid," stated Gruk.

"Xulthax is their dark god that lives among them in this city, Xulthaxia. He slumbers most of the time but awakens every so often to feed on the inhabitants."

"Why don't they just kill the thing and be done with it?" asked the yazirian.

"Oh they tried at first but failed. Each group that went to slay the god ended up in its belly."

"So they live here knowing that at any time that they could be on that thing's menu," Gruk said with incredulousness.

"Yepper."

"Why don't they find another city?" asked Bladen.

"In case you haven't noticed, there's a lot of nothin' on this moon, unless you're counting sand dunes."

"Point taken," said the human.

"You called this thing a god. Why?" inquired Gruk.

"Some of the eichs have taken to worshiping the thing. They make sacrifices and say prayers in the hopes that it will not choose them as its next snack," said the dralasite.

"So what else can you tell us about these beings? What'd you call them, eichs?"

"They call themselves "Eicholti." I just call 'em "Eichs." They're originally from another star system. From what I can tell there was a war with some aliens that they refer to as the "hunters." "

"The hunters were from a neighboring system. They're some kind of insectoid race, real bad news. Anyway, the hunters were kicking the stuffing out of them, so the eichs send out refugee ships in all directions in an effort to not be totally annihilated. "

The human and yazirian gave each other a knowing glance.

"They wandered from system to system for a while. Then, this group has some kind of mechanical problem with their ship and crash lands here. The crash site was very close to this city. The survivors found this place abandoned but it had a fresh water supply."

"They decided to dismantle their craft and make this place livable. There were a few thousand of them then. They set up that cloaking screen around the city to hide themselves in case the hunters ever showed up."

Bladen was astounded by that figure. The ship must have dwarfed anything fielded by the UPF.

"Once they had the city up and running they became quite bored and decadent. They have tech beyond what we've got in the frontier, mind you. They plug themselves into their computers and live their lives in some kind of digital fantasy."

"This digital fantasy is more important to them than real life. Their lives are almost a constant dream state. Many have difficulty separating reality from electric fantasy. Their lives outside the simulation I would describe as erratic at best. They'll rise to eat, gather what they want, and then some flight of whimsy will take them in another direction. They'll forget what they were doing in the first place and just plug themselves back in to their fantasy."

"How do you know so much about them?" asked Gruk suspiciously.

"I've learned to speak and read some of their language and have accessed their computer library. I've had a lot of time to kill."

"Where do the food stuffs come from?" inquired Bladen.

"They have machines that can rearrange simple molecular structures. They can literally make food out of sand and water."

"Incredible," stated Bladen.

"Don't they know their cloaking shield is failing?" asked Gruk.

"Some may, most probably not. Most of their time is spent in their dream worlds."

"Why don't they fix it?" asked the yazirian.

"They've been here for generations. They've lived almost totally carefree lives, except for the feeding habits of their god. All have forgotten how to repair the very technology that has sustained them because they care more for their dream lives than their real lives. The shield is only the latest system failure that I've uncovered. There are several minor outages all over the city," informed the dralasite.

"This certainly explains the guard at the airlock," said Gruk.

"Where are the beings now?" asked Bladen.

"Scattered in different parts of the city; lying on couches, beds, or wherever, all plugged into their electronic reality," said AkRICT.

Neither the human nor the yazirian cared for the idea of hundreds or even thousands of aliens lying around the city in self-induced digital comas. That was bad enough, but when they added in the fact of the prowling, feasting "god" the whole situation smacked of lunacy. Gruk's skin crawled at the thought that these beings had given up hope and assumed the role of prey and literally did it lying down.

"I'm having a hard time grasping their mindset," said Bladen.

AkRICT said, "Their fatalism comes from not being able to kill Xulthax. They tried every weapon in their arsenal with no positive results. I'd dare to say it is damn near unkillable. So, they have accepted their fate. I'd estimate that within a couple dozen years he's gonna have to look for a new food source because the eichs are gonna be extinct on this moon."

"We need to gather what we can and leave as soon as possible. I'd rather take my chances out in the desert than to stay here with a bunch of morons and their fantasies," stated Gruk.

"Don't be so hasty guys. I've been building a void capable shuttle piece by piece. I think it's complete but I can't fly the thing. I was actually foraging for foodstuffs when I ran into you two," said the dralasite.

A thrill went through both of the soldiers.

"I can pilot it," Gruk volunteered. "Where is it?"

"I've got it in a courtyard on the other side of the city. I'd be glad to have you check it out," said AkRICT.

"Lead on," said Bladen.

AkRICT lead them out a door and into a corridor that they had not been in before. They traversed halls and cut through several rooms. Suddenly the dralasite stopped.

"I heard something," said Akrict as he moved toward the wall on his left.

"Where?" asked Gruk, his weapon already in hand.

"I think through that door."

Gruk moved to the doorway and peered through cautiously. He turned quickly at the sound of quick movement and the sliding of stone. He stared at a blank wall, his companions were gone.

II. The Mask is Off

As the yazirian and human were focused on the dark room, Akrict, with a speed not congruent with his shape, slapped an oversized hand over Bladen's face. The human had difficulty breathing let alone crying for help. The dralasite performed another swift action of opening an unseen door behind him and scooping up the human in almost the same motion. The door was back in place by the time Gruk turned to see what was going on.

The human and dralasite were in a dimly illuminated hallway. Bladen struggled as Akrict's third arm slid a bolt into place. He drug the human swiftly down the hallway and away from the portal. Bladen soon passed out from a lack of air.

Bladen awoke shackled to a wall. He was in a small circular chamber with high domed ceiling. The apex of the dome was devoured in darkness. The walls and the floor were of the same greenish stone that composed the old city that the eicholtli had built on top of. There were three open archways that led out into unlit hallways and an altar-like stone near the chamber's center. His vibrosword was laid across it.

"How nice of you to join me Mr. Rand," said a familiar raspy voice.

Bladen looked to his right and saw Akrict with what appeared to be a stun rod in his hands.

"What is going on?" asked Bladen. "Use the sword to cut these chains."

"Oh I won't be doing any of that," responded the dralasite.

"What? What do you mean?" stammered Bladen.

"What I mean, soldier boy, is to feed you to Xulthax," smiled Akrict. As if on cue, two of the aliens wearing cowls stepped into view.

"If this is one of your jokes, it isn't funny. In fact, it's sick."

"I assure you it's no joke. You're gonna end up in that thing's belly," stated Akrict. "But first I'm going to have some fun."

The dralasite approached him with the stun rod out in front. Half mad with terror, the human fought against his chains like a trapped animal. Agony shot through him as the tip of the rod made contact with his stomach.

"I forgot to tell you, Mr. Rand, that I'm the high priest of the cult of Xulthax," said the dralasite. "My associates here believe that I am the offspring of their god and can ensure their survival." The rod struck home again.

"What about your ship?" desperately asked Bladen. "We can get off this rock. You don't have to do this!"

"About the ship," said Akrict a look of concern crossed his face, "Did I mention that it only has two seats? While it is true that I'm a trained engineer, the last job I held was as the captain of the Matilda Jayne. That was, of course, until my crew mutinied and cast me adrift in this star system."

Bladen had heard of the Matilda Jayne. It was a pirate vessel that harried the space lanes of systems across this part of the frontier. The crew had a reputation for ruthlessness. The crew of any merchant ship that would resist her was put to death.

"Gruk will kill you."

"Not after he hears how we were beset by the eichs," stated the laughing dralasite. "And, how you told me to run while you held them off. The last thing that I saw was you being overwhelmed by sheer numbers. What a heroic death! Aren't you proud? It kind of brings a tear to my spots."

Bladen renewed his struggles against his bonds. The stun rod struck again and again, each time it brought howls of anguish and pain from the human. Bladen had forgotten about the wandering menace that the

sounds of torture may summon and apparently so had his tormentor.

Bladen opened his eyes thankful for the respite that was occurring. Despite the pain that wracked his body he froze in place. His labored breathing was the only thing that betrayed the fact that life was still contained in his body. A paralyzing horror held the human firmly in its grip.

Bladen saw and heard Akric't's two alien allies in a life and death struggle with the monster. The creature had a multiple tentacle-like projections that held them fast. It pulled them into the darkness of one of the hallways. The dralasite turned and ran down the opposite corridor. They shouted in outrage, pled in desperation, and laughed hysterically. The creature made no response. Its only sounds were wet and slimy.

Each horrific cry was cut short; the only noises remaining were Bladen's short heavy breaths and the sickening bubbling sounds coming from the darkness. Those eternal seconds were more frightening than the thoughts of torture and death that he had earlier.

Bladen began to work his chain slowly and deliberately. His eyes tried to penetrate the darkness beyond the edge of the room's illumination. He thought that he could detect movement. He picked up the salty odor of the sea. Bladen could feel his blood running down his forearms from the fresh cuts made by the manacles that held him fast.

A bulbous projection emerged into the light. He thought that it must be a head given that it was covered in what he believed were eyes of a sort. Those orbs were as black as the void between suns. A cosmic malice beyond mortal understanding dwelt within them. The cassadinian could only break with the thing's captivating gaze through a supreme force of will.

The man renewed his efforts for freedom in a frenzy of terror.

The rest of it followed.

It was huge, bulky, and shapeless. Not unlike a dralasite but on a much larger scale. Bladen found it hard to gauge just how big the monstrous creature was. Its entire body surged and swelled at various

points only to deflate an instant later. It was a quivering mass that was drawing closer by the second.

Bladen loosed a terrified yelp as a pseudopod shot out and grasped at his arm. Its texture was also similar to the feel of a dralasite's rough skin but there was something else. The creature's touch was repulsive. It was lubricious and hungry. Bladen felt as though the filth of the creature had penetrated his skin and placed a stain on his soul.

Bladen howled like the damned as Xulthax began to envelope him. The thing tugged at him and at the same time began to flow over his form. Something landed on the altar with a hard thump and a curse.

III. Misplaced Allies

Akric't and Bladen had disappeared. Gruk stared at a wall of stone where they had been standing only moments before. His hackles went up. Something was definitely not right and he was now alone. Anger and fear were in competition as Gruk's primary emotion. The yazirian started to examine the wall for a secret catch or mechanism to open it when he heard a noise. He turned toward the source.

Gruk saw over half a dozen eichs approaching him. Some were armored while others were not. The yazirian didn't see any long arms amongst them. With a snarl and a low growl he drew back his zamra and charged.

The group of aliens was startled at the invader's audacity to attack when it seemed to be hopelessly outnumbered. The first to be within reach of the yazirian was cringing when the battle disk created a slit on his abdomen that allowed his internal organs to decorate the stone floor.

With his next motion, Gruk made a bloody ruin of another's face. The warrior avoided the off balance sword thrust of another. The sword clattered on the stones followed by a deluge of greenish-yellow blood. An awful scream filled the air. Confusion spread through the eichs. It was dawning on them that this was not a computer simulation.

An energy beam lanced by Gruk, the shooter cursed his shaking hands. His curses were cut short by a slash to the throat. The weapon dropped to the ground. The

eich's fingers failed to staunch the escape of his life's blood.

The smiling whirlwind danced among them and left a trail of blood in its wake. The eichs, unused to physical exertion let alone combat, were slow and sluggish compared to the yazirian. Their blades were too fast or too slow. Gruk had barely a scratch. His movements flowed naturally from one into another like that of a great cat. Although it was completely lost on them, the eicholti were witnessing the work of a zamra master.

More eicholti arrived. They must have disconnected from the network and heard the sounds of combat. Gruk, now bleeding in a few places, was surrounded. He saw a stairwell leading up. A vicious sweep of his battle disk gave him the instant that he needed to dash for it.

Blades darted at him. Gruk made a series of movements that would have made any professional gymnast green with envy. The swords caught empty air.

He had barely cleared five steps when a semi-conscious alien met him on the stairs. The eich had the uncomprehending look of someone just brought to consciousness from a deep sleep. Gruk promptly smashed his weapon into its nose and pushed him down the stairs toward his pursuers.

The eichs at the bottom of the stairwell tripped over the stunned body of their comrade. Gruk continued his ascent. The aliens howled and cursed.

The yazirian burst through the only door at the top of the stairs. There were no occupants. The place reminded Gruk of a temple of sorts. There were rows of benches arranged in neat and orderly rows. However, instead of an altar, the room contained a low circular wall similar to an ancient well, only there was no apparatus for retrieving water or anything else. Gruk could faintly make out some kind of sounds wafting up from the well.

He stepped inside and shut the door. His eyes scanned the room for anything that might be of use to block the door. There was nothing and no other exits. He was trapped. The sounds from the well reminded him of anguished cries. He could feel the warm caress of the blood rage wrapping around him.

Yazirians have hard coded into their DNA the ability to go "berserk", as humans would say, with a battle lust. This trait makes them some of the most fearless hand-to-hand fighters on the frontier. Gruk was no exception. He welcomed the rage and would use it to either strike terror into his foes or exact a hefty toll for his own life.

He could hear the chittering as they neared the top of the stairs. He could barely make out what could have been voices emanating from the walled pit. Gruk positioned himself and readied the battle disk. His vision was becoming clouded with red. The skin of his muzzle pulled back baring his teeth. A low growl emanated from his throat.

The door flew open. The eicholti poured in. With a snarl, Gruk flew in to action. Three were mortally wounded from his zamra's first sweep. The tide of aliens was irresistible. He gave ground but the ground he gave was carpeted with blood and bodies.

Eventually, his heel touched the low circular wall. The eiches renewed the ferocity of their attacks. Gruk, defiant to the end, did a backward summersault over the rim of the wall. He spread his arms and legs. The patagia, that allowed him to glide, billowed and slowed his descent down the shaft.

His abrupt stop was more like a crash than an actual landing. If he had not been able to slow himself, he could have easily been knocked unconscious or have broken something. He was atop some kind of raised platform. Someone was screaming to his right. Gruk blinked and focused his eyes. It was Bladen. Some gods awful thing was in the process of devouring his friend.

The yazirian moved his arms to push himself up. He felt something metallic move as his hand brushed against it. Gruk was on his hands and knees on top of the altar. He grabbed at the thing and brought it forward.

It was Bladen's vibrosword. He turned it on without thinking. The yazirian let out a guttural snarl. Bladen's desperate shrieking filled his ears. Gruk saw that a nightmarish thing was wantonly enveloping the human.

The battle lust still had Gruk firmly in its grasp. It was the only reason that he wasn't overcome with the

babbling lunacy that nipped at the fringes of his brain. He struck the quivering undulating mass of flesh.

The part of the beast that was encasing Bladen receded. The creature focused on this new interloper. The vibrosword had hurt as it clove through the thing's malleable mass. Gruk was sprayed with gore as he withdrew the blade for another strike.

The creature moved with a speed that one wouldn't associate with such a thing. It washed over the yazirian in a tide of flesh. He slashed and stabbed with a speed and ferocity that the creature had never experienced. Its flesh gave almost as though it was not quite solid. Gruk was awash in the ichors that came from its wounds.

Despite Xulthax's best efforts, he could not immobilize this strange biped's stinger. Over the long centuries, he had devoured many bipeds that had stingers without much thought. This one, however, had a stinger that hurt.

Gruk was dimly aware of anything other than the vibrosword that he thrust and slashed over and over again. The nightmare had tried to constrict and crush him but it recoiled from the caress of the blade. It formed appendages that tore and rent at him from too many angles to defend against. Molten fire erupted in all of the various cuts and tears in his flesh as the beast's digestive juices started to coat him. If it was going to eat him then he was going to give the thing a belly ache.

The struggling pair moved away from Bladen and into the darkness of one of the hallways. Gruk knew that he had left his feet some time ago. He was being held aloft inside of Xulthax. The beast was trying to disorient him in an effort to disrupt his merciless assault.

Gruk's body was beginning to betray his rage. The punishment inflicted upon him by Xulthax was staggering. The yazirian knew that soon he would be ushered to paradise beyond the moons. He kept the sword in motion, machinelike. Finally, he struck something that felt solid. Gruk gave the sword a savage wrench with what remained of his waning strength.

Xulthax shuddered violently. Gruk was jostled around and spat out. The creature's body expanded and contracted in an impossibly chaotic way. It poured

itself quickly away from the stunned yazirian. A wet trail marked Xulthax's passing. Gruk pulled himself up to his feet very slowly and began walking.

IV Garden to the Stars

Bladen struggled as he half-carried Gruk down the hallway. They were on the trail of AkRICT. Bladen hoped that they would come upon a medical device of some kind so he could treat the yazirian's wounds.

He had been relieved when the big yazirian had staggered back into the light. At the same time, he was horrified by the awful condition that Gruk was in. His mane and collar were matted down, lacerations crisscrossed his body. Gruk showered the floor with the thing's ichor with each trembling pain filled step.

Bladen's heart had almost stopped when the struggling Gruk had tripped and fallen over one of the half-digested eichs that Xulthax had regurgitated during the fight. The yazirian had risen slowly with a grim determination to free his companion. Gruk had just enough strength left to open Bladen's manacles before collapsing.

The hallway was dark but a light could be seen in the distance. A breeze could be felt but it was not the cool air conditioned air of the complex. It was hot, dry and oppressive. Bladen knew this hall led outside.

The two held no conversation as they made their way. Bladen was focused on keeping his grip on the yazirian and staying on his feet. Gruk was utterly spent. His struggle with Xulthax had taken every ounce of energy that his muscles could muster. Every part of his body was leaden. His horrific wounds throbbed and pain lanced through him with each jarring step the two took.

Bladen set his bloodied companion down about five meters from the light. He wanted to do some recon before trudging into a possible trap with the injured yazirian. Sword in hand, he silently made his way to the end of the corridor.

The hall opened up into a courtyard. It appeared to be oval in shape. An operational fountain was in the center. The sound of water tantalized his ears. The eichs' ancestors had purposely not enclosed this area. Bladen could make out shallow irrigation troughs in the stone walk paths. Plants in raised beds ran around

the entire outer edge of the plaza. The once well-manicured gardens were now a tangle of weed like plants.

The human cautiously approached the fountain. The water was clear but tepid to the touch. It was still cooler than the surrounding air temperature. He surveyed the area to make sure no one else was around. He saw only a gaping archway on the other side that appeared to run into another courtyard.

The cassidianian splashed water on his face and took several drinks before retrieving Gruk. He helped the yazirian to drink before picking him up and setting him in the fountain. He immersed Gruk in the water as it was the most expeditious way to clean him. The ichor and gore came off with little effort.

“Dog face, I’m gonna leave you here while I check out the next courtyard.”

Gruk nodded his agreement.

Bladen stayed just inside the arch of the gate that led to the next courtyard. It was similar to the other only bigger. However, there was no fountain. Instead, Akric’s piecemeal shuttle dominated the center.

It was an ugly vessel but the soldier thought it was the most beautiful thing that he had seen since crashing on this rock. The dralasite had obviously pieced the thing together from items that he had scrounged from around the city. The idea occurred to him that Akric’s efforts may have caused the malfunction of the cloaking shield by taking components that he then put into this ship.

The vessel was short and squat. The main engine took up the entire rear section. Bladen guessed some kind of chemical booster rocket was attached to the keel. The shuttle was sitting on its aft which was resting on a low platform.

Bladen threw himself flat against the wall as movement to his left caught his eye. It was that no good son-of-a-blob that had tortured and abandoned him to his fate. He watched as the dralasite dragged a case over to the shuttle’s platform.

He saw Akric climb inside of the ugly little craft after shoving the case inside. Bladen left the shelter of the arch and swiftly positioned himself to the side of the shuttle. He waited for the treacherous glob to exit.

Sweat was beading on his forehead and threatening to run down his face and into his eyes. He could feel the hot wetness between each finger that gripped the vibrosword. The raw patches on his arms where the manacles had been stung as sweat blazed a salty trail across them. The tension in his muscles was building.

Bladen instinctively rolled forward at a sound behind him. He sprang to his feet, turned around and at the same time switched on the sword. A low humming sound emanated from it. Akric had exited by another hatch and had been moving up behind him stun rod in hand.

“I’m unpleasantly surprised to see you soldier boy,” said the grimacing pirate. “Just how did you get away from Xulthax?”

Bladen, sword at the ready, spat on the ground.

“Oh, I can see you’re still a little upset about the whole manacle thing.” Akric’s words oozed with sarcasm. “Look, I’m not disappointed that the god didn’t eat you. It just means that you and I can play some more.”

He started to circle to the human’s left. The business end of the stun rod crackled with the electricity waiting to be discharged. A cruel smile played across his face.

Bladen held himself in check. There was only one thing that he wanted more than to gut this shape-shifting piece of scyf. It was to see his family again. To do that, he had to survive.

He surmised that Akric’s hand to hand skills were probably as good as his. He bet that the dralasite was attempting to get at a stashed weapon while they were squaring off. Bladen knew that he had to control Akric’s movements and keep him from getting the advantage.

“I see your friend isn’t with you. Can you tell me where he is so I can console him about your untimely demise at the hands of the eichs?”

“Nug you,” said Bladen through gritted teeth.

“I wouldn’t expect such naughty words from a distinguished member our armed forces.”

Bladen detected a slight shift in the dralasite's color. They naturally communicate through changes in skin color and scent. This change meant something.

The human tensed as he believed the pirate was up to something. A grin came over Akricht's facial lump. True to form the pirate had grown an arm out of his back which he used to take a handful of the sandy ground and throw it at the soldier's face.

Bladen threw up his off hand, closed his eyes and ducked his head. At the same time, he side stepped right and swept his blade in front of himself. The sword deflected the incoming thrust of the stun rod.

Akricht cursed as he had overcommitted to the attack and was off balance. He fell face down. However, the dralasite was back on his feet by the time Bladen had regained his composure. The pirate pressed the attack hoping to immobilize his opponent with the stun rod.

Bladen took up a defensive posture. Though no master of the sword, he deflected each thrust deftly. Akricht attacked in a flurry hoping to score an eventual hit by sheer volume.

The rapidity in which each thrust of the stun rod decreased. Bladen took that as a sign that the pirate was becoming winded. He was glad too for his muscles were screaming in protest after the ordeal that he had endured.

The soldier looked for the opportunity to attack but it just wasn't there. The pirate's blows still occurred with enough frequency to keep him on the defensive. Bladen lost his footing on loose rubble and fell backwards sprawling.

Bladen landed on his back hard. The back of his head collided with the hard packed sandy soil. He was seeing stars when the stun rod contacted his leg. Every muscle tensed as current flowed through him. The pain was excruciating. The sword fell from his grasp.

He looked up to see the dralasite framed by the gas giant. A look of anticipation was visible as he thrust the rod at him again. Bladen tensed and brought his knees up to his chest.

The thrust struck nothing but dirt. Bladen kicked both legs with every ounce of his remaining strength. The pirate fell backward. The stun rod skittered across the

open ground. Bladen reached for his blade and was on his feet in an instant.

The pirate ran for the archway through which Bladen had come. The stun rod lay abandoned. The soldier had a sick feeling in his stomach as he realized Akricht was sure to discover the incapacitated Gruk. He ran in pursuit.

Bladen stopped his run when he entered the adjoining courtyard. In fact, he stood stone still. Akricht was standing next to the fountain his back to it facing the human. Gruk was nowhere to be seen. The pirate smiled the smile of a victorious predator. Bladen's eyes were drawn to the pistol like gadget that the dralasite was aiming at him.

"Well, soldier boy," hissed Akricht, "it looks like our dance has reached its conclusion. Sadly, your dried husk will become a permanent fixture in this garden. But, have heart, my new partner and I will think of you often and tell others of your bravery."

Bladen's mind raced for a solution. But those thoughts gave way to an extreme sadness as memories of his family encroached. He became resigned to the fact that the pirate had beaten him. He was going to die and would never see his wife and their girls again.

"Any parting words, like where your partner is?" said Akricht.

Bladen breathed deep and began, "Nu-."

Akricht's hand tightened on the pistol.

Gruk exploded up out of the water behind the pirate. One hand gripped Akricht's forehead. The other held his zamra. The battle disk slashed across the "neck" area of the dralasite's head lump. Blood began to gush from the wound.

The shot emitted from the alien weapon went wide of its mark. Bladen fell to his knees and gaped in astonishment at the change in events. Akricht's free hands went to the wound as he turned to face his attacker.

Gruk brought the disk down in an arch. The dermis of the shape shifting pirate split open in a line that ran from between his eyespots to just short of where one of his legs sprouted from his trunk. The pistol fell to the ground.

The dralasite toppled backwards with the smack of skin on stone. The resulting wave of force caused his entrails to mushroom up several centimeters from the wound's opening. Their splash down created a mini tsunami of gore that washed out to either side of the prone body.

Bladen watched in slack-jawed shock as the yazirian pulled himself out of the fountain. The big yazirian stood trembling before him.

"Gods of Yaz maneless! You gonna help me to the shuttle," asked Gruk with a crooked smile of exhaustion.

Bladen held one of Gruk's arms over his shoulder and started for the awaiting shuttle.

"How is it that I'm always helping you out?" asked the human.



Scene by A. J. Davis

END

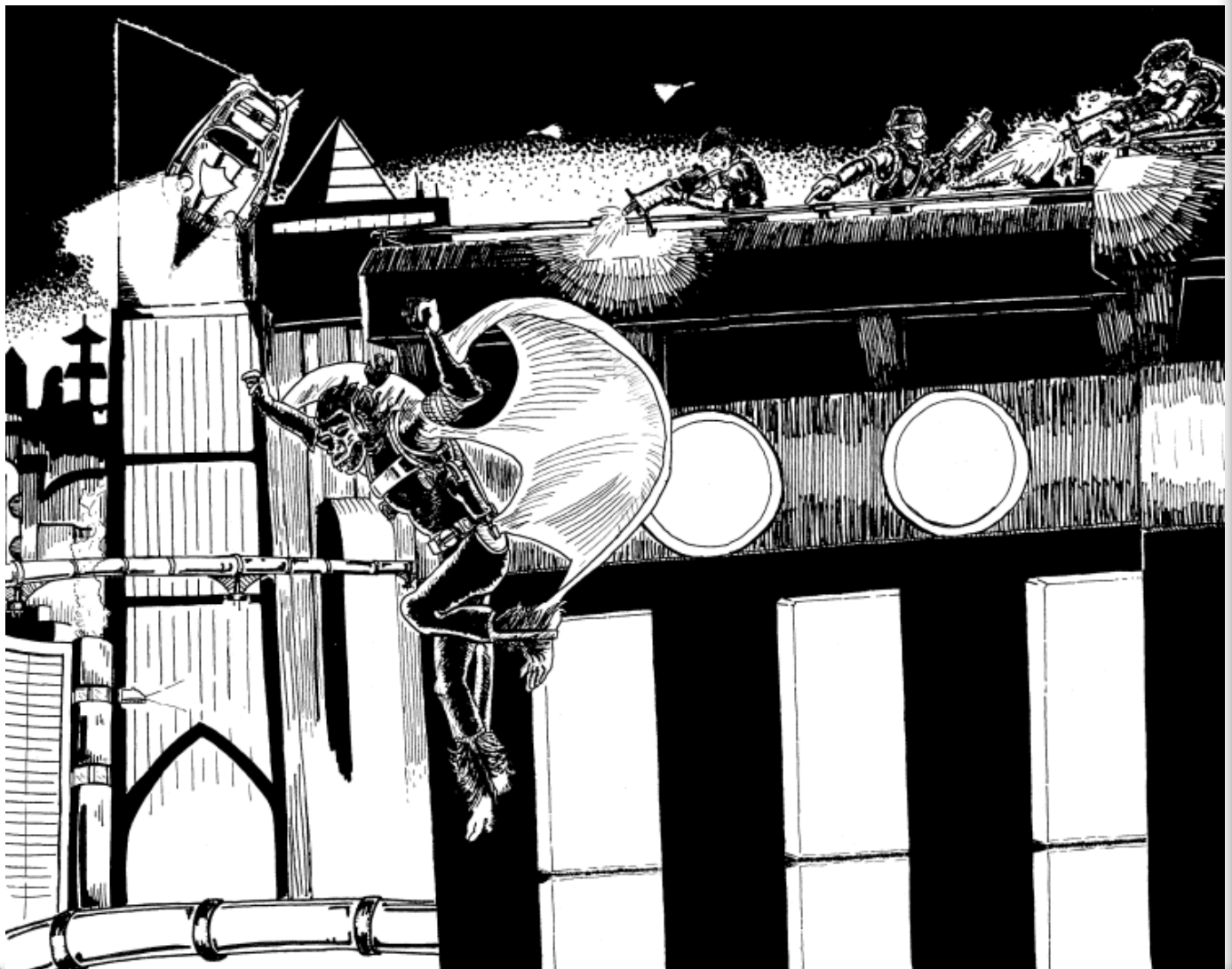

CHARACTER RACES

Author's Note: This series of articles presents information on the races that exist beyond the Frontier. These races and the information about their homeworld have been adapted by me from the material being created for the Star Frontiers (URS) Project which is being hosted on the starfrontiers.us development site.

Belphans

By Allen Trussell

Average size	1.7m tall
Average Mass	80kg
Average Lifespan	150 Years
Body Temperature	37° C
Reproduction	Heterosexual Viviparous

PHYSICAL DESCRIPTION AND STRUCTURE

Belphans are slender humanoids that follow the basic symmetry of a Human. These beings have many similarities to lupuses having long slender ears that rise from the back of their heads and can move independently of each other granting the Belphan a wide field of hearing. Belphans have large eyes that range in color throughout the browns, and they have a short muzzle with long sensory whiskers framing it. Their nose is small and seems to incessantly twitch, and their small mouths are filled with teeth that are well suited for their herbivorous diet.

Internally Belphans are quite similar to Humans except that the muscle bunches on their legs are far denser than Human muscle resembling that of a Humma which allow them to leap great

distances and their wide feet are well suited to absorb the impact of their jumps.

SENSES

Belphans sense of vision is about as efficient as that of a Human, though they depend more on hearing and scent than on vision. Their hearing is so acute that they are able to hear frequencies that are inaudible to most races. Belphans however have a small membrane that operates much like a human eyelid that offers them protection from sudden loud noises. Belphans sense of smell is so well developed as to enable a Belphan to distinguish individuals by scent from a distance.

SPEECH

The Belphan's have developed two distinct languages, one which they use among the races they come in contact with and one which is only understood, and can only be spoken by Belphans themselves because it is not so much as spoken, as it involves very subtle gestures and movements of the ears and nose. Belphans are known to communicate with others of their kind at the same time they are talking to non-Belphans which makes many non-Belphans leery about dealing with groups of these beings.

SOCIETY AND ATTITUDES

Belphans are considered crazy by the races they have come in contact with, because they seem to lack the instinct of self-preservation that other beings possess. A Belphan will charge into battle against a group of Adrainians without batting an eye, trusting to luck to see them through.

Belphans love practical jokes, though their jokes tend to be dangerous and it is almost impossible to get a Belphan to remain focused or serious for long periods of time. Belphans however have

mastered technology equal to that of the Frontier and do produce trade goods, so it is assumed that there are Belphans who are more sober than the ones commonly encountered traveling around in interstellar space.

The Belphan homeworld was hard hit by the Sathar in recent attacks, though some speculate that most of the damage was done by the Belphans themselves rather than by the invading Sathar and now the surviving Belphans are gearing up for war which is a frightening prospect.

SPECIAL ABILITIES

Heightened Hearing: Because of a Belphan’s heightened sense of hearing they gain a +10 to their Intuition rolls to avoid surprise.

Highly Developed Smell: All Belphans have highly developed olfactory senses. These are so acute that a Belphan can recognize and identify even very weak odors that it has encountered in the past, including people. Any Belphan gains a +10 bonus to his Intuition rolls to identify a person, or substance by scent, unless something has masked or removed the scent.

Spring: A Belphan can spring up to 10 meters horizontally from a standing start and can leap down 10 meters without taking damage, landing on his feet.

ATTRIBUTE ADJUSTMENTS

Dexterity/Reaction speed	+10
Intuition	+10
Personality/Leadership	-10



Art by Emily Vitori

Belfar

System Information	
Location	94.3 light years from Prenglar
Sun type	G6
Color	Yellow
Classification	G6
Temperature*	5,500°K
Life**	10,000
Radius***	1
Habitable sphere****	3-6
*Temperature is in degrees Kelvin	
**Lifetime is listed in millions of years	
***Radius is listed in terms of Sol’s Radius (700,000Km)	
**** Planets in orbit within these orbits have the possibility of sustaining life without artificial means being employed to convert the planet so that it can support Human or human-like races.	
Number of planets	8

Core	Core Type	Diameter	Ave Temp	Gravity	Orbital Period	Notes
Rock	Rock	34,920km	304 ⁰ C	1.3g	90 days	
Desert	Magma	36,204km	154 ⁰ C	.9g	260 days	
Pre-Garden	Magma	36,204km	154 ⁰ C	.9g	380 days	
Green house	Magma	32,100km	4 ⁰ C	1.0g	540 days	Belphan Home World
Glacier	Liquid	28,200km	-23 ⁰ C	.8g	810 days	
Ice Ball	Magma	67,200km	-46 ⁰ C	1.2g	1,560 days	
Chunk	Magma	17,760km	-62 ⁰ C	.6g	2,250 days	
Chunk	Magma	15,942km	-84 ⁰ C	.3g	3,700 days	

Notes: Belfar is a large star system that lies 3 light years from the Beldrim Nebula a luminous cloud of gas and proto-matter 5ly in diameter. Belfar is home to a major race of beings known as the Belphans. This spacefaring race have not made extensive use of the planets in their star system, but their industrialization has permanently altered their homeworld.

Recently a small force of Sathar ships entered the Belfar star system from the direction of the Beldrim Nebula and attacked the Belphan homeworld with a ferocity never before seen in the Sathar. The Belphans managed to defeat the Sathar in pitched battle, and though the Sathar have not returned the Belphans believe that because their star system is strategically placed that perhaps the Sathar were just trying to get a feel for the opposition they will face when attacking the Belphans and that it is only a matter of time before the Sathar return in greater numbers.

Belfar

Orbital position	4 th
Number of satellites	2
Diameter	32,100km
Orbital period	540 days
Rotation period	40 hours
Seasons	4
Axial tilt	36 ⁰
Core type	Magma
Gravity	1.0g
Atmospheric pressure	.9
Tectonic plates	19
Stress factor	16%
Classification	Greenhouse
Hydrosphere	63%
Cloud cover	42%
Chance of Precipitation	34%
Average temperature	4 ⁰ C
Average wind speed	5kph
Major land masses	1
Minor land masses	3

Natural Resources

Belpharite crystals	7,000cr/ton at source
Nickel	10,000cr/ton at source
Belfaen silver	worth 5,000cr/ton at source
Belfarin scented wood	2,000cr/ton at source

Notes: Belfar has one major continent in its northern hemisphere and has three minor continents, two of which straddle the planet's equator, and one that is close to the planet's southern icecap. The planet's inhabitants mostly live in the main continent with a few scattered settlements along the coast of the other continents. Belphan industry over the last 200 years has permanently marred the planet's atmosphere by increasing the methane and carbon dioxide levels to the point that the planet is now retaining more heat than before, which has almost completely melted the northern ice cap of the planet.

Belfar is a world of wide plains with large expanses of rain forest in two of the southern continents. Belfar has many native species of life, but only the Belphans are considered a major race. The planet was recently attacked by the Sathar, and several Belphan cities have been greatly damaged by the attack.

Belfar has four seasons. The first transitional season sees the average temperature of the planet raise by 12°C to an average of 16°C. The second season sees the temperatures continue to raise to an average temperature of 28°C with a subsequent increase of rainfall (average chance of rainfall becomes 68%) The planet's second transitional season sees the temperatures drop down to their normal average of 4°C, but the rain continues to fall at a higher percentage than usual (68% chance of precipitation). In the fourth season the chance of rainfall returns to normal.

Civilization Information

Classification	Homeworld
Progress level	7 (Frontier level)
Government type	Participating Democracy
Law level	Level one (Concealed weapons, poison gas, explosives prohibited)
No. major settlements	32
Population	32,000,00
Planetary wealth	50,000cr/person/year
Spaceport type	Major (private docking facility, excellent repair facilities, construction of system ships and starships, warehouse facilities, a customs house, and Spaceport security office)
Manufactured Resources	
Tea	1,000cr/ton at the source
Caustic Alkali	2,000cr/ton at the source
Vehicles	10,000cr/ton at the source
Robots	10,000cr/ton at the source



BACKGROUND INFORMATION

Recovered from internet archive at:

<http://web.archive.org/web/20011031214214/http://www.geocities.com/Area51/Cavern/1475/sfnetbook.html>

from Mark White's SF netbook

Food on the Frontier

By Mark White

As unified as the Frontier may be against threats to its safety, the vast diversity of the Frontier races manifests itself particularly when it comes to food. Having developed on different worlds and under different conditions, it is logical that each of the individual races would have their own particular requirements and tastes when it comes to nutritional satisfaction. Here is a discourse on the various cuisines of the Frontier races.

Dralasite

Dralasites are a restaurateur's favorite client, as they tend to eat almost anything, as long as it is scented and seasoned to taste: "It all ends up at the same place, anyway," as the famous Dral philosopher Otuumbagee once said. Despite their willingness to swallow anything which has been flavored properly, there are some foods which Dralasitas savor and some which they often despise.

Dralasite ingestion involves forming a pocket within their bodies (though some prefer to extend the edges of the pocket away from the body to form something of a mouth), putting the comestibles inside, and then closing the pocket around the food. Drals can actually open more than one food pore at a time and often do so to speed up the digestive process; they also never use the same pocket for both speaking and eating, as the vocal cavity is connected to a voice box which would make a poor Dral asite very nauseous if food entered it.

One fact which, from time to time, causes friction between a Dral asite and a member of another race is that, during and after large meals, Dral asite digestion tends to create audible and olfactory indications of their recent repast, which the other races tend to find displeasing. Although this is a bodily function which Dral asites insist is beyond their voluntary control, an

occasional easily-offended Yazirian restaurant owner will restrict the access of Dral asites to their establishment based on this occurrence (especially in cafés where alcohol is served, which tends to increase the evidence of their gastric activity).

Even though Dral asites will eat vast variety of foods, they do have their favorite scents, flavors, and foodstuffs:

Panongila seed -- a definite favorite as far as any Dral is concerned; they use the ubiquitous *Panongila seed* to make many varieties and forms of seasonings, including but not limited to powders, shavings, grindings, gels, pastes, sauces, creams, broths, etc. Despite what meal their having, chances are it has some form of *Panongila seed* in it.

Budovasi Dral -- 'the tonic of Dral' comes from the scented leaves of the *Budova* tree on Groth (Fromeltar) and is used in the creation of a number of Dral asite confections and steam bath intoxicants, specifically the bath crystals of the same name. The *Budova* leaves themselves even have a pleasant aroma to the other Frontier races as well, who frequently use *Budovasi Dral* (or the raw *Budova* leaves) in incense and perfumes; even Yazirians respect the Dral asite spice which is used to make the famous (among Yazirians) Grothian ale.

Ool -- if anything was ever precious to the Dral asites, than it is this. *Ools* are (human-) fist-sized melons which have an overpoweringly-delicious scent and flavor to Dral asites, young and old; these bright blue fruits have an almost intoxicating effect on Dral asites, who cherish even the slightest hint of scent. Dral asites prepare them by cutting the top off of the ripened fruit (then eating the top), mashing the pulpy insides, and mixing a favorite spice or two (often *Budovasi Dral*). The other races tend to find the smell of the prepared *Ool* very relaxing, Humans in particular, and often prepare them as air fresheners prior to a visit from a Dral asite friend.

(Note: Humans can curry much favor from a Dral asite, if they offer the prepared melon to the visitor at the end of the visit -- as a farewell snack. It is rumored that some wise bussinessbeings have made out like bandits when attempting a takeover of a Dral corporation by simply offering the company president

a prepared *Ool* at the end of the negotiations, and another rumor suggests that some store managers keep *Ool* cuttings in the cooling vents in order to keep the Dralosite customers interested in shopping there.)

Human

Second only to the Vrusk, Humans have the least sensitive taste. However Humans can and do eat a wide variety of foods, ranging through nearly every form of life. Despite their variety, Humans seem to enjoy a particular array of food types, mainly cooked and flavored meats, raw and cooked vegetables, certain grains and fruits, and a limited variety of fungi, bacteria, and animal by-products.

Here is a just a sampling of popular Human foods on the Frontier:

Tapoffala -- a dish consisting of leafy vegetables, diced fruits, and chopped cooked meats covered with a sauce made from blended raw bird eggs and vegetable oils, and any number of different seasonings. Vrusks seem to enjoy this food; however Yazirians tend to go for a more meaty variation of the *tapoffala*.

Meat Steaks -- a common meal dating back to the prehistory of Humans, the *meat steak* is favorite among not only Humans, but Yazirians as well. Prepared in a wide number of variations on the same type of food, the *meat steak* is usually served with a special seasoned sauce and is often accompanied by steamed vegetables and baked breads. Vrusks might actually enjoy the flavor of steaks, but cannot bring themselves to eat something so esthetically unpleasant.

Pastry wheels -- another common Human delicacy is the *pastry wheel*. These are flat pastries topped by a vegetable paste, fruits and meats, solid mammal lactations which are all baked together. Vrusks particularly enjoy eating pastry wheels until they discover the origin of the mammal lactations.

Vrusk

Of all the Frontier races, the Vrusk is, by preference and necessity, the most finicky eater. They prefer soft and fleshy foods to extremely hard or tough fares, as the mouthparts of the Vrusk were apparently designed by nature for chewing and cutting. Typical Vrusk staples include insects and insect larvae; leaves, and fleshy fruits and plant parts; tender meats; and most types of processed plant and animal products. Vrusk typically have difficulty with tough meats, woody plant parts, animal bones, hard animal shells, and hard nuts.

The Vrusk palate, although less sensitive than those of Humans and Yazirians, is much more exclusive in taste. The reason for this is that Vrusk seem to lack the sensation of bitterness in food, however detect two other flavor types which other races lack (the Vrusk words for these flavor types, "kr'kt-chit'k" and "kr'kt-k'ask'ts", do not translate into any other language). They seem to particular enjoy fish and shellfish; most arthropods (including some which are venomous or toxic to other races); soft, stiff plant parts (such as celery and carrots); and have a particular taste for extremely spicy foods, stiff tubers, and several varieties of flowers and fruits. They eat their food by holding the food object with one or two hands and the larger pair of maxilla as the mandibles cut and chew it; after which, the smaller pair of maxilla push the chopped meal into the oral cavity and is swallowed.

Vrusk usually prefer not to drink liquids, but can often be found drinking water, fruit juices, and extremely weak fruit wines. They especially do not drink strong alcohol or milk products, as these can severely damage their digestive tracts.

Since Vrusk lack the ability to create a vacuum in their oral cavity, they must either tilt back their heads and pour any liquids down their throats, or use a special squeeze or pump vessel in order to siphon the drink up a straw and into the mouth. Since most Vrusk find tilting their heads back uncomfortable most use containers resembling squeeze bottles.

Common Vrusk fares include:

T'd'zk-kr'tsik -- a mixture of diced *Kiza't plant* fruits and roots, large *Ch'ta-zk* berries, and *V'vaz'dsik* grubs, all steamed and marinated in a strongly-seasoned *Kizk-kar nettlebush* leaf broth. This meal has a flavor that is found to be pleasingly acceptable to all races except Dralosites, who can't stand the scent of the *Kizk-kar nettlebush* leaves (though they often eat the meal with a broth other than the *Kizk-kar nettlebush*).

Kr'ek-t'chk -- a salad of various spicy vegetables and small fish (known collectively as *Ka-chk'chk*) served raw and often covered with a milky sauce of seasoned *Vr'tk-k'chek* weed sap. This is one of those recipes edible by the Vrusk alone, as the *Vr'tk-k'chek* weed is poisonous to most other species.

K'banks'la -- a favorite Vrusk meal consisting of a heavily-seasoned, living *K'vnk'z* slug on a bed of marble-sized peas, *Fauilla* mushrooms, and *K'tsa* fruits. Only a handful of humans in the Frontier can fully stomach a meal of *K'banks'la*, despite the aesthetic

value it holds to Vrusk. Surprisingly, most Yazirians relish fresh *K'banks'la*; and some political theorists suggest that it's the true reason why Yazirians originally accepted the Vrusk, who served it at the meeting of their first contact.

Yazirian

Despite the fact that Yazirians tend more toward the carnivorous side of being an omnivore, they still include a wide variety of foods in their diet aside from just meats (as some Vrusks would lead you to believe). Unlike the other Frontier races, which tend to bring their favorite recipes with them as they cross the wide expanses of Void space, Yazirians tend develop new meals and dishes on each newly settled world they inhabit, most often restricted to the edible lifeforms available on that world. Below is a sampling of a few Yazirian recipes along with their planet of origin:

Yaghurtz (Histran) -- this spicy meal consists of layers of uncooked *Rulaga* fish and *Muwari* bird (which are found around the same watering holes) between toasted pieces of the giant fresh-water *Cho-choga* plant seasoned with native Histran apple-beans and spices. *Yaghurtz* is one of the few Yazirian meals which most of the members of every race enjoy, and thus, Histran has an exclusive market on the export of packaged *yaghurtz* (Even though other companies produce replicas and products similar to Histran's, the distinct flavor of Histran *yaghurtz* is widely-recognized and most people seek it out expressly).

Granuga (Hargut) -- a cocktail served on many worlds, the *Granuga* of Hargut is the most popular Yazirian mixed drink in the Frontier, falling only shortly behind Grothian ale as the most popular legal intoxicant among the Yazirians of the Frontier. While the original *Granuga* was a much more powerful intoxicant, the modern variety is still more than most Humans and Dralasites can handle in one serving, though Yazirians can seemingly drain shot after shot before succumbing to its inebriating effects. *Granuga* consists of the distilled spirits of both the *Kalanga* nuts and *Cho-hoka* leaf of Hargut, mixed with equal portions of a sparkling wine made from the fruits of fermented *Granu* berries. The original, more powerful predecessor of the modern *Granuga* was said to have also included a powdered red fungus from the wooded foothills of Hargut (which some historians suggest helped the early Yazirian settlers to enter into the historically frequent battle rages with which the Hargutians were able to repel the pirate marauders who descended on the planet soon after its colonization).



Subject: Religion, skills, Homeworlds, etc.

By Michael Bauser

This old blog post was found lying around and we thought this might inspire some new directions in your game.

The Exodites are a Yazirian religious group that believes Yazirians were the subjects of an unidentified insectoid race who ruled the Yazirian's homeworld. According to Exodite teachings, a female Yazirian named Anarla Erkon heard the "voices of the stars", and led the Yazirian people on an Exodus to the Frontier. In addition to insectoid Overlords, Exodite theology also speaks of one-eyed demons whose purpose was to hunt and kill Yazirians.

The Overlords are Klikks and demons are heliopes, from SF 3. This one ties into some complex campaign background I was working on, namely what the Homeworlds were like.

The Family of One is an offshoot of the Exodite Church who believe that the planet Hentz is the divinely appointed home of the Yazirians, and that the only point of the Exodus was to bring them to Hentz.

All members of the Family consider themselves related and use the terms Brother and Sister to address each other. All members of the Family must live on Hentz (although they may visit other worlds) and wear uniforms denoting name, age, profession, rank in the church, etc.

The Family of One gets mentioned in Alpha Dawn & Zeb's Guide, GOD Co, in ZG, and the Defenders in a Dragon article.

The Family of One owns the Galaxy Overall Development Company, a terraforming megacorp. Although they consider Hentz the true and perfect creation of God, the Family of one sees all other worlds as open to terraforming. Other religious groups have disagreed with this stance and formed a new cult, the Defenders of the Divine Will, to oppose terraforming.

The Warrior's Path is an ancient Yazirian religion that holds there is a hierarchal structure to the afterlife, with varying levels of paradise spread around a Worldtree. Those "who follow the warrior's path" believe only in the traditional forms of life-enemies, rivals or opponents that one endeavors to destroy.

The Warrior's afterlife shows this; the highest level of the Worldtree is for those who destroy their life-enemy. The succeeding levels are (in descending order) for those who die fighting their life-enemies, those who die for other reasons without defeating their life enemies, and for those who never pick a life-enemy.

Followers of the Warrior's Path often use archaic melee weapons. Non-Yazirians are allowed in this cult, and many Humans, Hummas, and Saurians have begun to join.

Sorta inspired by Viking mythology.

The Vrusk Church is an ancient social institution of the Vrusk people. It holds that a divine entity (referred to as the Divine Imperatrix), rules the cosmos and decides the final fate of each soul before it is placed on the mortal plane. The Vrusk also believe that this final fate is foreshadowed by its success in life, meaning Vrusks successful in business are destined for Heaven. (For the most part, this allows Vrusk to be as ruthless as necessary in their business dealings, as they try to prove they belong in Heaven. Furthermore, the belief that they don't control their own fate allows them considerable latitude to create codes of behavior, because they do not fear offending the Imperatrix.)

Have mixed feelings about this one myself. Mostly I was trying to invoke a sense of extreme "capitalist Protestantism". The idea of giant capitalist insects strikes me as very Social Darwinist, but I've never been able to work it out to my satisfaction.

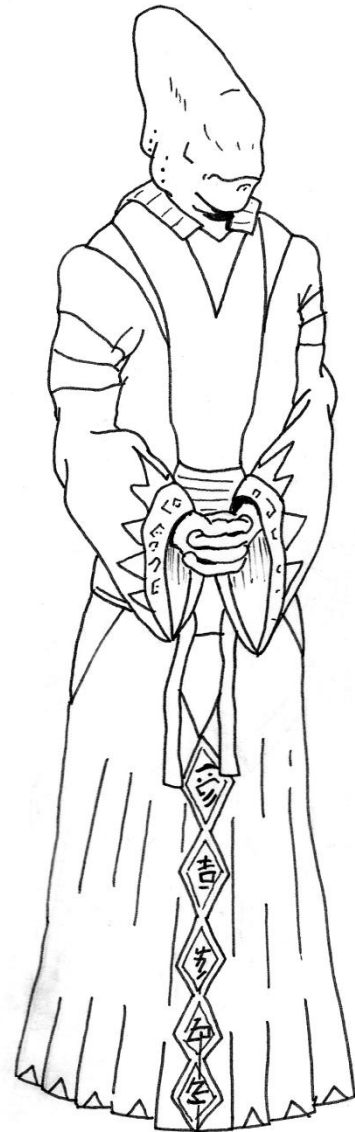

Blind Alien by J. A. Davis



CLASSIFIEDS

Are you a Yazirian who has lost their clan?
 Are you a Vrusk without a trade house?
 Are you a Dralasite with no one to debate with?

Are you a Human with no idea what to do with your training and skills?

We are here to help you not only find your way but to bring to you a sense of family.

Give us a buzz at Chronocom 1A345 [] DP
 or meet one of our family recruiters and join us for a meal at our local hostel.

We are saving a place for you.



Hentz Collective

The Hentz Collective offers the largest collection of traditional Yazirian heirloom and new stock seeds, outside of the Family of One.

If you are tired of dealing with those religious fanatics, give us a call.

Subspace relay#98098909811111

Garbage Haulers In Port Lauren on strike

They want better equipment, pay, and benefits.

A small price to pay for clean streets.

Have you been beyond the Frontier?
 Visited new worlds and met new races?
 Why not give us a call at B141000~^^^

A collector of unique cultural items would love to hear your stories and examine or buy your souvenirs.

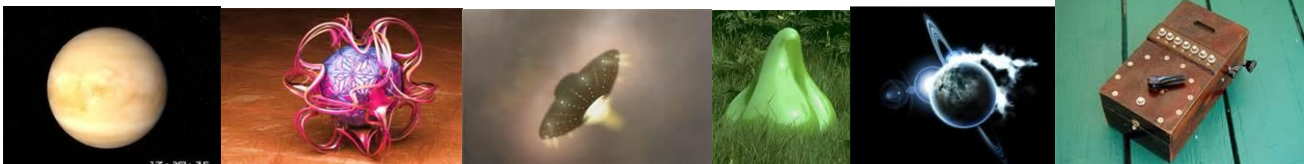

Have you told all your jokes 1000 times?
 Have you worn out your whoopee cushion?
 Is your rubber chicken hard as a Yazirian's butt?
 Time to visit Crazy York's Joke store for all your comic needs.
 Located at Central Square next to Merco recruiting office.

