

ISSUE

16

December
2010

STAR FRONTIERSMAN

Magazine



Station Hopping on a Fistful of Credits

STAR FRONTIERSMAN

Magazine

THE CLIHKS

by Eric "Bilygote" Johnson..... 1

SYSTEM BRIEF

Sundown by Eric "Bilygote" Johnson 3
 Theseus by Allen Trussell..... 7

FRONTIER CREATURES

by Allen Trussell..... 9

BACKGROUND MATERIAL

UPF Agencies by Victor Gil de Rubio 12
 Adventure Concepts by Thomas Verreault/jedion357 13
 Data Searches on the White Light System
 by Thomas Verreault/jedion357 15
 New Cadres and Cults by Thomas Verreault/jedion357 16
 A Fist Full of Rumors by Thomas Verreault/jedion357 17
 Civil Service Organizations in Star Frontiers
 by Matthew Crymble..... 19

LAAMVIN

New player race by By parriah (Jess Carver)..... 21

CREATIVE REFEREEING

Strategies to Encourage Players in Creating Plot Hook Laden
 Backgrounds by Thomas Verreault/jedion357..... 23

FRONTIER FICTION

Discovery: Prologue by Tom Stephens..... 25
 Demons by Thomas Verreault/jedion357 27

VEHICLES

UPF Meteor Class Assault Shuttle by Gary Cliff / BD Cerridwen /
 Georgie 30

FRONTIER HISTORY

Return to Voltarnus by Thomas Verreault/jedion357..... 32
 Frontier Timeline by Thomas Verreault/jedion357..... 34

COSMIC CATASTROPHES

by Tom Stephens 46

GAME REPORT

Tales from the Falcon Part II by Richard Rose..... 54
 Charge of the Dralosite by Thomas Verreault/jedion357 57

EQUIPMENT

Robot Archetype: Courierbot by C.J. Williams 61
 Robot Equipment by by C.J. Williams 63
 Cloud Flyer..... 66

DISEASES IN THE FRONTIER

by Eli Arndt..... 67

OPTIONAL RULES

Just How Many Weapons Can I Add to My Ship? by Thomas
 Verreault/jedion357 69
 Tasks of the Skilled Frontier by Thomas Verreault/jedion357 70
 The Villainous NPC Master Plan by Larry Moore 72
 PSA Skill System by Dominic (Nick) Pelletier..... 75
 Adventure Bots! by C. J. Williams 78
 Teleportation Tech: The Art & Science of Energy Travel in the
 Frontier by Scott Mulder 86

CLASSIFIEDS

Oh come on, you know you like these! Back cover

On the cover: A busy station by GJD

Art credits:

- » C. J. Williams 61-66, 78
- » Dan LaValley 74
- » Eric Winsor 95
- » Scot Mulder 13, 14, 40, 69, 86-94
- » GJD 30-31, 41
- » Jess Carver 21
- » Ryan Baker 24, 71
- » Shell 27, 29, classifieds
- » Wayne Peters 28



FOREWORD

Merry Christmas To All and To All A Good Frontiersman!

A huge thanks to the entire *Star Frontiersman Staff*, they worked very hard to get this issue out by Christmas – Sam Quier, Tom Stephens and Thomas Verreault.

Out largest issue yet (eventually there had to be one right?) you'll find a special treat from Dominic (Nick) Pelletier after the classifieds. A mammoth list of AD/KH and SFman equipment, vehicles, races etc. Thanks Dominic!

Raise your dice hand high!
 Larry Moore
 lmoore@dwdstudios.com

THE CLIKKS

By Eric "Bilygote"
Johnson

THE CLIKK

Author's note: This article expands upon the alien race Klikk as hinted at in the module SF3: Sundown on Starmist by Garry Spiegle. The Clikks are presented here as a NPC race only.

From UPF File XA000179554263 Code ULTRA BLACK EYES ONLY

What is known about the insectoid life form XA0073, popularly known as "Klikk", has been gathered primarily from three sources. These sources are archeological digs in the Sundown System, artifacts recovered from the planet Starmist, and interviews with the survivors of the VSS Last Leggs (See File: IR000000527895 Last Leggs Crew Interrogations).

The Klikk presence in the Sundown System seems to have been wiped out in a highly improbable series of disasters occurring on several different planetary bodies in a relatively short time span (See File: EST000095528791 Sundown Rogue Theory). The source of the disasters is unknown at this time. However, based on the evidence gathered thus far we believe a planet sized rogue moved through the system.

The Clikks seem to use a combination of mechanical and bio-technology. This could be an indication that their home planet has poor mineral resources to exploit. Since so few artifacts have been examined it is impossible to speculate which type of technology is more prevalent. It is also impossible to know their current capabilities, as our artifacts are at least five hundred years old.

Operation: Bughunt (See File: BOF0000051933571 Bughunt) is trying to ascertain the Klikk military threat level as well as their sphere of influence...

APPEARANCE AND STRUCTURE

A typical Klikk female stands 3.7 meters at the shoulder while the male stands at 2.2. Both sexes have six limbs and a tough exoskeleton. Its four rear legs allow the Klikk to move quickly. These legs also give the creature excellent stability.

Klikk females are built for combat. They are quick, agile, and ruthless. Females lack the manipulator appendages that the males possess. Instead, they have raptorial arms (2d10 damage). Prey is held securely between these serrated, spiny forelegs. The male's arms end in a hand with three fingers and an opposable thumb. Their exoskeleton is extremely hard chitin, which acts as partial polyplate armor.

They have triangular heads poised on a long "neck," or elongated thorax. Clikks can turn their heads 300 degrees to scan their surroundings with two large compound eyes and four other simple eyes located between them. The jaws chew from side to side and have multiple small extensions that manipulate food during eating. The antennae are vestigial, serving no apparent purpose, like a human appendix.

Like an insect, a Klikk has a three-segmented body, with a head, thorax and abdomen. The abdomen is elongate and covered by the wings in adult females. Males do not have wings. Unlike the Vrusk, Clikks do not have a spinal column.

Their colors vary, ranging from light greens to pinks. Most Clikks are forest-green or brown.

SENSES

A Clikk's sense of hearing is equal to a Vrusk's. Its sense of taste is more highly developed than a Human's, but its sense of smell is almost non-existent. A Clikk's ability to turn its head 300 degrees gives it superior all-around vision. A Clikk always has a +2 Initiative Modifier because of its superior vision.

SPEECH

Klikk speech is similar to that of the Vrusk, combining a series of clicks, buzzes, chirps and whirs forms their vocabulary. To the untrained, the languages are indistinguishable.

SOCIETY AND CUSTOMS

Cunning, combined with their intellect, have made the Clikks the undisputed masters across a large stellar empire. That empire, however, has been in a steady decline for over 300 years. The decline is a result of high infant mortality and combat losses.

The Klikk appear to live in clan, family, or pack units. The groups work together against aliens but are prone

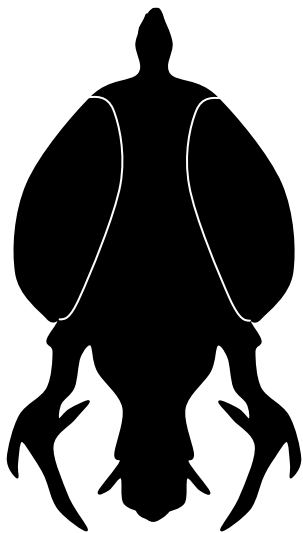

to violence towards a different clan for the slightest of reasons.

Slavery is prevalent in Clikk society. Members of conquered races are enslaved or used as cattle. The most widely used race is the Heliopie. Details on the Heliopes can be found in SF3: Sundown on Starmist. It is not uncommon for a slave to be eaten just because the Clikk happens to be hungry.

The females are the brawn, while the males are the brains. A male will fight if needed however Clikk military units only utilize males in support roles such as technicians.

The Clikks do not have life partners or mates. A male will mate with as many females as possible. There is a high probability that, during or after the coupling, the female will bite his head off and eat him. Even without his head, the male will still complete the task.

Females regularly lay dozens of eggs in a small case, and nymphs hatch looking much like tiny versions of their parents. Often, their first meal is a sibling. This is one of the reasons that males only make up approximately 26% of the population.

ATTITUDES

The Clikks are brutal, warlike, bloodthirsty, and industrious. Unlike the Sathar, there is nothing subtle about how they seek dominance over other races. They view other races as food, slaves, or both. They consider the Vrusk and the Zuraqqor as the biggest threats among the Frontier races. Something about their physical appearance triggers a hard-wired instinct to fight. The Clikks will kill them on sight.

...Evidence indicates the Clikks utilize large energy weapons however, no individual sized energy weapons have been uncovered (See File: IR000000527895 Last Leggs Crew Interrogations). They may not be technologically advanced to miniaturize these weapons yet. Their preferences seem to be kinetic kill and sonic weapons based on artifacts recovered...

A Clikk vessel will never return a hail from a ship. Their greeting will come from the barrel of their railgun.

SPECIAL ABILITIES

Ablative Chitin

Clikk chitin covers all vital areas and acts like a combination albedo suit and skeinsuit. It absorbs half

damage from all beam and physical attacks. Half of the damage decreases the Clikk's stamina.

The chitin is somewhat ablative; as it absorbs damage it becomes scored and darkened, unable to absorb damage. When the chitin has absorbed 100 points of damage it stops protecting the Clikk.

Electric Field Generation

2d10 electric shock, Clikk must touch target. This ability can be used only once per encounter.

Sonic Resistance

Clikks take one-half damage from sonic weapons.

Immobilization

Clikks can attack three times per round in melee combat. If both arm attacks hit the target is immobilized (strength check to break free)
Raptorial arm, 2d10 kinetic damage
Bite, 1d10 kinetic damage

Raptorial Arms

Attacks always penetrate skeinsuits.

Leaping

females 150 m length, 80 m high, males lack this ability

AVERAGE STATS

Ability	Female	Male
STR/STA	70/70	40/40
DEX/RS	60/50	50/60
INT/LOG	25/25	60/60
PER/LDR	20/20	45/45

Editors Note: You can obtain a remastered copy of SF3: Sundown on Starmist from the StarFrontiersman.com Adventure Module section or scans of the original in the Modules section on starfrontiers.com.

SUNDOWN

By Eric "Bilygote"
Johnson

Author's note: This article expands upon the Sundown star system as presented in the module SF3: Sundown on Starmist by Garry Spiegle. In this article you will find original material, material from the module, and from Zebulon's Guide to the Frontier. All credit for the non original material goes to the respective authors.

SUNDOWN SYSTEM BRIEF

For almost 100 years, the UPF has known about the Sundown system. Despite its discovery in 14FY the system was off limits for nearly three years as litigation tied up the status of the system and the rights to it. Traders and explorers, in increasing numbers, have made the trek to the edge of the known frontier. From Araks, Sundown is only 11 light years and 12 light years from Scree Fron. Sundown is now a hub of activity. A colony of Heliopes and a UPF scientific outpost exists on the frigid planet of Starmist. The system also contains alien ruins, Cassidine Development Corporation and DelveCo (a subsidiary of Pan-Galactic) mining operations. Despite the growth and industrialization that the system has experienced, Sundown remains a sparsely populated system.

There is a palpable tension as the UPF, CDC, DelveCo, and the Vrusk house of Zik'trin all vie for power in the system. There is also a liberal amount of independent miners working the two asteroid belts. All must work in opposition to the Heliopes as a growing segment of their population is becoming educated and seeking to exert sovereignty over Sundown. Skirmishes, corporate raids and corporate sponsored piracy are common occurrences in the system.

KNOWN HISTORY

Sundown was discovered by the VSS Centispeed in 14FY. It was soon followed by an independent mission conducted by the VSS Last Legs. The crew of the Last Legs discovered advanced alien technology and a Sathar outpost on Starmist. This prompted the UPF to intervene in the disposition of the system rights. The Clarion Department of Extra-solar Affairs sued for jurisdiction. The resulting court case drug on for years. The ruling by the High Court declared Starmist off limits to all but official UPF missions. Unlimited rights to the rest of Sundown were awarded to the Vrusk trading house of Zik'trin whose vessel discovered it.

House Zik'trin realized they didn't have the resources to exploit Sundown. They immediately sought to lease

the rights. Cassidine Development Corporation and DelveCo soon accepted Zik'trin's terms. In exchange for the mineral rights, both companies agreed to exclusively use House Zik'trin for their supply, raw material and personnel transportation needs. At the same time Zik'trin imposed preposterous docking, rent, and maintenance fees for ships associated with Trans-Travel. This maneuver effectively gave Zik'trin a stranglehold on transportation within, to, and from Sundown.

All parties soon discovered that they were not the first to enter the system. Alien ruins have been found peppered throughout the system except for Starmist. There is speculation that these sites may have belonged to a race that may have been in competition with the Tetrarchs. No hard evidence has been found to support this theory. What xenoarcheologists have found are hints of an insectoid race that relied on biotechnology. This race is being referred to as the Klikks.

Blue Plague began on Starmist as a result of genetically engineered animals released into the wild by the Sathar. The Heliopes were highly resistant to the disease and it wasn't discovered until more interaction with the UPF commenced. There are rumors that the disease was introduced to the planet by a crashed Klikk vessel and that the story about the Sathar is just a cover to hide the truth. There are other rumors that indicate the Blue Plague was brought to Starmist from elsewhere in the Frontier.

By the beginning of the Second Sathar War in 80FY, the UPF had built a permanent space station in orbit over Starmist. CDC and DelveCo had fought several skirmishes over choice locations. Trans-Travel sponsored piracy had been a thorn in the sides of all parties. Many independent mining operations had moved into the two asteroid belts. Sundown continued to thrive well into the war.

THE PENETRATER RAID

Towards the middle of 86FY, the Sathar cruiser Penetrater jumped into the Sundown system. It began making short work of the freighter traffic in the outer system. Officials in the system were unaware of the cruiser's presence and chalked the disruption in trade to piracy as Trans-Travel was ramping up anti-Zik'trin activity.

The truth became known as the UPFS Harbinger, a frigate, fell victim to the Penetrater's avarice. The UPF Commander of Sundial station orbiting Starmist was able to get the corporate entities to act in concert

against this new threat. A rag-tag fleet defended the DelveCo's orbital refining facility at Schloss. The Penetrater was defeated but a heavy toll was extracted from the defenders.

THE SECRET HISTORY

The planet Starmist was formed eons ago around a different star. The planet, unable to hold its orbit, swung wider and wider around the star, and finally hurtled into space, a cold, frozen ball of ice. After ages, it was captured by its present star, Sundown, taking up an orbit somewhat tighter than its original orbit.

Starmist's journey through the system was directly responsible for the formation of the asteroid belts. The gravitational disruption to these two forming planets caused them to break apart.

The Heliopes, the humanoid inhabitants of Starmist, are from a different system. They were slaves of a race called the Klikks, resembling the Vrusk, who explored the Sundown area. One of the military exploration vessels, mapping in the region of Starmist, had problems that required dumping any extra weight. Unloaded on Starmist were some nonessential tech items and all nonessential personnel. Nonessential personnel included the Heliopes. Before leaving, the Klikks subjected the Heliopes to a mind-wipe that caused amnesia. Heliopes who survived on the planet filled in their missing past by making up legends and stories that eventually became their history. Culture among the Heliopes is shallow since they have developed on Starmist for only 1000 years. The Heliopo religion is focused around relics left by the Klikks.

THE PEOPLE

The only intelligent species is an erect, bipedal hominid having a primitive nomadic economy and low technology. These natives are known as Heliopes in their own language.

There are nearly 200 tribes spread out over five large rifts. Heliopes are superb fighters, and they have competed successfully for food and space with plant and animal life. Warfare and violence among the tribes are common. A village developed by the Heliopes is the only one of its kind. The village is located next to the river and contains reasonably complex homes. The buildings house families and their primitive government. The villagers are the only Heliopes who are not nomadic.

Heliopes stand erect and average two meters tall. They look slightly reptilian. The head is man-shaped with a long, sensory, whip-like antenna dropping down from the rear and curving back up into the air. Heliopes have superb hearing because this appendage is sensitive to atmospheric vibrations.

Heliopes are omnivores, having large teeth and mandibles for chewing and cutting. Heliopes have one, large central eye that is protected by bony ridges and

two nictitating membranes. Heliopes possess two long arms with average strength but the 'hands' are two pincers, slightly rigid, with a sharp nail along the edges. Two extremely powerful legs dominate the lower body. A long tail sweeps up like a scorpion's, to rest over the shoulder. The Heliopes are neither right nor left handed but right or left shoulder-tailed. The feet are large, long, and splayed. All Heliopes seem awkward and clumsy in confined spaces and look totally unsuited to riding in vehicles or on animals. They are excellent swimmers.

Heliopes have translucent skin. The normal network of upper musculature and veins is visible and Heliopes vary in colors from violet to deep purplish red. The whip tail changes color toward the tip to opaque, shiny black.

Because of their body chemistry the Heliopes are immune to normal electric current and will take only one-half damage from lasers. Because of their antennae, Heliopes take double damage from sonic weapons. Both pincers and mandibles deliver a 1d10 bite. The damage from the mandibles is subtracted from a skeinsuit value but the damage from a pincer is against the character through the skeinsuit. The tail is not prehensile and it cannot strike. Heliopes carry pouches of small stones which they can throw with terrific force. The bullet/stones cause 1d10 of damage if they hit. Inertia shields and skeinsuits will affect the missiles. Although Heliopes use harpoons to fish, they are not adept with such tools as weapons.

The basic social unit of the Heliopo tribe is the family. Marriage ties cause complex relationships. Government is a simple system of chiefs and subchiefs chosen for ability in combat and leadership. Priests have great influence on the tribe but no official power.

All Heliopes enjoy color and collect gemstones, polished rock crystals, and similar baubles. They are superb sculptors and do intricate, detailed work on wood and bone. They paint and decorate their tails and mandibles in patterns that differ from tribe to tribe.

Average Heliopo Statistics			
STR/STA	45/45	PS	Pincers (1d10)
DEX/RS	45/45	IM	23
INT/LOG	45/45	RW	23
PER/LDR	45/45	M	23

Special Abilities: Immune to electrical attacks; ½ half damage from lasers; double damage from sonic weapons; pincers penetrate skeinsuits; 3 attacks per round in melee (2 pincers/1 bite).

PLACES OF INTEREST

Carousel – Carousel is a series of space stations orbiting Sturm. They act as ports of call for merchants to trade with House Zik'trin. The Vrusk also use them as cross docks and warehouses for goods flowing in and out of Sundown. One of the stations is a fully functional shipyard used primarily for repair and overhauls. The repair facility can handle up to 16 hull

sizes worth of ships. For example; one ship of HS16 or four ships of HS4.

Customs Outpost 1 – There are 9 customs outposts scattered about the system covering both star routes and in-between. These are some of the only locations where Star Law operates off-planet, mostly due to the presence of the Sathar. The officials regulate the “legality” of items flowing in and out as well as collect tariffs. All ships entering and exiting the system must stop at one of these stations. Zik'trin ships are exempt from customs inspection; after all they own the system and set the rules governing traffic in and out. Outside merchants cannot trade within the system without a permit issued from one of the customs stations and is closely regulated by House Zik'trin.

Holiday Station – This station is the central destination for off duty workers. The mammoth facility boasts more attractions and hotels than some major cities. Holiday station is run by Starplay Enterprises under lease from House Zik'trin. A small Star Law office is located here. Despite this, a large black market thrives here.

Sundial – Sundial is the UPF research station orbiting Starmist. It is primarily a research station but also acts as neutral ground for parties who have disputes. Diplomatic embassies are also located here as well as the main Star Law office. Unknown except to select members of the command staff, Sector 6 (Issue #6) uses the base as a launching pad for covert operations.

Te'Den – A dwarf planet in Sundown's Kuiper Belt, Te'Den serves as a pirate outpost. It was financed and built by Tans-Travel. Tans-Travel still supplies funds and information to the pirates through several shell companies and exerts some control over their raiding activities. It is a place of skullduggery and semi-lawlessness. The most infamous pirate vessel of the system, the Black Scar calls this port home. The captain is a Dralasite named Droog. Droog has a reputation for an iron fist and a disposition to match. *Referee Note; this base of operations is known only to a few within Trans Travel and its location is guarded. Outside the pirate circles of influence it's only a rumor.*

Sundown I (Sigis)	Terrestrial, 0.3 AU
Year	57.5 days
Gravity	0.7
Diameter	25,512.4 km
Climate	385° C
Sigis is rich in heavy metals and is the site of extensive CDC mining operations.	
Sundown Ia-u	Moon, airless rock
Gravity	Negligible - 0.5
Sigis has 21 moons captured from the inner belt. They range in size from .001 diameters to 0.6.	

Sundown II (Rimini Belt)	Asteroid Belt, 0.7 AU
Year	205 days
The Rimini Belt has numerous huge, 1,000 km+, asteroids. Many independent mining operations are active in this belt. CDC runs several ore processing stations in the belt.	

Sundown III (Starmist)	Terrestrial, 1.2 AU
Year	460 days
Gravity	0.93
Diameter	9,880 km
Climate	Cool; warm to frigid, Avg. 5° C
Due to a slow rotation, Starmist never formed any extensive soil depth. The poor development of soil coincided with the slow development of life forms. Water and atmosphere collected in the rifts and they slowly became habitable. Vegetable, insectoid and fish-like forms were the first to appear and are now fairly widespread in the rifts. Mammals and related species are few in number. The nights are very dark on Starmist because there is no moon and few close stars.	

Sundown IV (Kirchgoens)	Jovian Gas, 2.7 AU
Year	1,552.79 days
Gravity	2.6
Kirchgoens is composed of hydrogen 80% and helium 20% with traces of water, methane, ammonia. It has a core of frozen rock. Kirchgoens has 38 moons and 1 ring.	
Sundown Iva-al	Moon, airless rock
Gravity	Negligible 0.5
Kirchgoens has 38 moons ranging in size from 0.03 in diameter to 0.6.	

Sundown V (Giessen)	Jovian Gas, 5.1 AU
Year	4,031.1 days
Gravity	2.3
Giessen has a solid iron core mixed with nickel and trace amounts of lighter elements. The gas composition is water 45%, ammonia 15% and methane 40% with traces of fluorine and argon. This giant has 50 moons and 2 rings.	
Sundown Va-ax	Moon, airless rock
Gravity	Negligible 0.5
Wetzlar (Sundown Ve) is covered by methane ice. Buried beneath the ice is a derelict Clikk ship. This is the same ship that abandoned the Heliopes on Starmist.	

Sundown VI (Lahn Belt)	Asteroid Belt, 9.6 AU
Year	10,410.58 days
The Lahn Belt contains many smaller asteroids than the Rimini Belt. It is also the home to many independent miners.	

Sundown VII (Tubingen)	Terrestrial, 18.4 AU
Year	27,624.52 days
Gravity	0.4
Tubingen has been a hot bed of conflict between CDC and DelveCo. Several battles have occurred to seize control of the planet.	
Sundown VIIa-c	Moon, airless rock
Gravity	Negligible 0.7
Ayers (Sundown VIIa) has a ring system which is being mined by DelveCo.	

Sundown VIII (Schloss)	Dwarf Planetoid, 36.0 AU
Year	75,600 days
Gravity	2.2
A frozen ball that has been mapped but not leased for development. It has one moon. There is a rumor that House Zik'trin discovered intact Clikk ruins and is keeping all of the new discoveries to themselves.	
Sundown VIIIa (Sturm)	Moon, airless rock
Gravity	0.8
Sturm is the home to House Zik'trin. It has a customs station orbiting the moon.	

Sundown IX (Thuringia)	Terrestrial, 76.8 AU
Year	235,564.51 days
Gravity	1.3
CDC has leased Thuringia. It has proven to be an excellent source of precious metals. Thuringia has three moons.	
Sundown IXa-c	Moon, airless rock
Gravity	Negligible 0.4
These moons have been leased to DelveCo, much to CDC's consternation. They contain several mining operations. They are medium size, 0.15 - 0.28 in diameter.	

Sundown X (Butzbach)	Jovian Ice, 149.5 AU
Year	639,778.78 days
Gravity	4.65
Butzbach has a solid inner core surrounded by a liquid outer core. The gas composition is water 10%, ammonia 30% and methane 60% with traces of hydrogen deuteride. This giant has 38 moons and 3 rings.	
Sundown Xa-al	Moon, airless rock
Gravity	Negligible 0.7
These moons have not been leased as of yet. Sector 6 has set up a listening post disguised as a deep space survey team.	

STAR DATA

Star Type	K5 Orange Main Sequence
Diameter	2.0 Sol
Mass	0.7 Sol
Temperature	4,200 degrees Kelvin
Luminosity	0.266 Sol

Sundown III (Starmist)

Type	Terrestrial
Orbital Radius	1.2 AU
Year	460 Standard days
Gravity	0.93
Diameter	9,880 km
Day	21 Hours
Hydrosphere	42% (53% Ice)
Atmosphere	Breathable
Climate	Cool; warm to frigid, Avg. 5° C
Trade	None
Native Life	Heliopie
Government	No centralized government, tribal
Population	Light, 100% Heliopie
Moons	None

Because of a number of factors, including slow rotation, the planet never formed any extensive soil depth. The poor development of soil coincided with the slow development of life forms. Water and atmosphere collected in the rifts and they slowly became habitable. Vegetable, insectoid and fish-like forms were the first to appear and are now fairly widespread in the rifts. Mammals and related species are few in number. The nights are very dark on Starmist because there is no moon and few close stars. The UPF has an orbital facility named Sundial and several ground based sites.

Sundown VI (Lahn Belt)

Type	Asteroid Belt
Orbital Radius	9.6 AU
Year	10,410.58 Standard days

The Lahn Belt contains many smaller asteroids than the Rimini Belt. It is also the home to many independent miners.

Sundown VIII (Schloss)

Type	Dwarf Planetoid
Orbital Radius	36.0 AU
Year	75,600 Standard days
Gravity	2.2

Schloss is a frozen ball that has been mapped but not leased for development. It has one moon. There is a rumor that House Zik'trin discovered intact Klick ruins and is keeping all of the new discoveries to themselves.

Sundown VIIIa (Sturm)

Type	Moon, airless rock
Gravity	0.8

Sturm is the home to House Zik'trin. It has a customs station orbiting the moon.

Sundown X (Butzbach)

Type	Jovian Ice
Orbital Radius	149.5 AU
Year	639,778.78 Standard days
Gravity	4.65

Butzbach has a solid inner core surrounded by a liquid outer core. The gas composition is water 10%, ammonia 30% and methane 60% with traces of hydrogen deuteride. This giant has 38 moons and 3 rings

Sundown Xa-al

Type	Moon, airless rock
Gravity	Negligible - 0.7

These moons have not been leased as of yet. Sector 6 has set up a listening post disguised as a deep space survey team.



Sundown I (Sigis)

Type	Terrestrial
Orbital Radius	0.3 AU
Year	57.5 Standard days
Gravity	0.7
Diameter	25,512.4 km
Climate	385° C

Sigis is rich in heavy metals and is the site of extensive CDC mining operations. Sigis has 21 moons captured from the inner belt. They range in size from 0.001 diameters to 0.6.



Sundown Ia-u

Type	Moon, airless rock
Gravity	Negligible - 0.5



Sundown II (Rimini Belt)

Type	Asteroid Belt
Orbital Radius	0.7 AU
Year	205 Standard days

The Rimini Belt has numerous huge, 1,000 km+, asteroids. Many independent mining operations are active in this belt. CDC runs several ore processing stations in the belt.



Sundown IV (Kirchgoens)

Type	Jovian Gas
Orbital Radius	2.7 AU
Year	1,552.79 Standard days
Gravity	2.6

Kirchgoens is composed of hydrogen 80% and helium 20% with traces of water, methane, ammonia. It has a core of frozen rock. Kirchgoens has 38 moons and 1 ring. They range in size from 0.03 in diameter to 0.6.

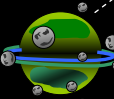

Sundown IVa-al

Type	Moon, airless rock
Gravity	Negligible - 0.5

Sundown V (Giessen)

Type	Jovian Gas
Orbital Radius	5.1 AU
Year	4,031.1 Standard days
Gravity	2.3

Giessen has a solid iron core mixed with nickel and trace amounts of lighter elements. The gas composition is water 45%, ammonia 15% and methane 40% with traces of fluorine and argon. This giant has 50 moons and 2 rings. They range in size from 0.001 diameters to 0.6.



Sundown Va-ax

Type	Moon, airless rock
Gravity	Negligible - 0.5

Wetzlar (Sundown Ve) is covered by methane ice. Buried beneath the ice is a derelict Klick ship. This is the same ship that abandoned the Heliopie on Starmist.

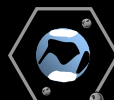

Sundown VII (Tubingen)

Type	Terrestrial
Orbital Radius	18.4 AU
Year	27,624.52 Standard days
Gravity	0.4

Tubingen has been a hot bed of conflict between CDC and DelveCo. Several battles have occurred to seize control of the planet. Tubingen has 3 moons. They range in size from 0.01 diameters to 0.3.

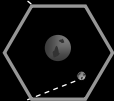

Sundown IX (Thuringia)

Type	Terrestrial
Orbital Radius	76.8 AU
Year	235,564.51 Standard days
Gravity	1.3

CDC has leased Thuringia. It has proven to be an excellent source of precious metals. Thuringia has three moons.

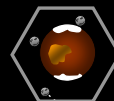

Sundown IXa-c

Type	Moon, airless rock
Gravity	Negligible - 0.4

These moons have been leased to DelveCo, much to CDC's consternation. They contain several mining operations. They are medium size, .15 - .28 in diameter.



THESEUS

By Allen Trussell

HISTORY

The Theseus star system was originally explored by Aktion Timertikos, an explorer and entrepreneur, in 299 pf. His ship, the *Argos*, traveled the system and became the first major settlement on the habitable world of Minotaur. Many parts of the *Argos* can still be seen today in museums and structures in the old parts of the capital city, Maze.

The worlds of the Theseus system, and many of the sites on them, are named after ancient Greek legends, most notably that of the Minotaur. Timertikos claimed descent from Theseus himself, the heroic slayer of the Minotaur. Many of his comrades were also of Greek descent, and thus Greek names are common among the population to this day.

During the Second Sathar War, Theseus played an important role in supplying the UPF as well as covert operations, including deliberate misinformation being "leaked" so the Sathar could be deceived. Minotaur itself was thankfully spared any direct attack during the war.

THE PEOPLE

Minotauran society is stratified into social classes, and forms of nobility are used among the elite. Though any citizen has the right to pursue his or her own dreams and aspirations, only the nobility can hold government office, and only by a decree from the Council of Elders can a person be granted or stripped of noble title. The people of Minotaur are almost all human. They work and play in a well-developed terrestrial world with many freedoms, although under the dictates of a noble class of rulers. Crime is low, and work is plentiful. People are encouraged to immigrate to other colonies, and to aid in the development of other worlds in the Theseus system. All Minotaurans consider themselves superior to most of the UPF, and claim ancestry to various nobles of old, even those who hold no title.

PLACES OF INTEREST

Maze: The capital of Minotaur, and seat of authority for the Theseus system. In addition to government offices, Maze also provides a wealth of museums, theatres, art galleries and offices. This sprawling city covers the island of New Crete, which sits in the center of the Labyrinth Sea; ancient evidence of a long-ago meteor impact. Maze is home to Starplay Enterprises, and its large campus is as much an office as it is an entertainment complex which is the envy of the UPF.

Ninland: Founded by the yazirian Siot Nin, Ninland is a large amusement park containing cutting edge technologies. A mixture of robotic, holographic and live actors bring the park to life. Ninland is divided into several regions over a vast area, each with its own

unique theme. Despite the presence of StarEnt, Ninland is not one of its properties. Siot Nin was a former employee of StarEnt, who left after a disagreement with corporate executives. He founded Ninland as a way of competing with StarEnt; while a great success on Minotaur, Nin has been unable to expand the concept to other worlds, usually due to conflict with StarEnt.

Athena FSS: This Fortified Space Station orbits Minotaur, providing military and communication services to the planet and system. All starships are required to report at *Athena* and a squadron of fighters as well as a small UPF task force are stationed here. The station is commanded by Commodore Larina Timertikos, a direct descendant of Aktion. *Athena* is a military installation; with the recreational facilities on the planet below, there is no need for such aboard the station.

DESCRIPTIONS

Icarus - Icarus has a thin atmosphere of carbon dioxide and hydrogen sulfide. It has a great deal of mineral wealth, but its near tidal lock and toxic atmosphere makes mining a subterranean effort. Major mines produce many major metals.

Daedalus - Daedalus has numerous moons, the largest of which - Iapyx, Perdix, Cocalus and Eupalamus - are worlds in their own right (all 3,000 to 6,000 km in diameter), though none are capable of supporting life. Mining operations are extensive on all four of these moons.

Minotaur - There are three main continents on Minotaur - Aethra, Aegeus and Asterion - with numerous large islands.

Naxos Asteroid Field - There are thousands of asteroids in this field. Many of these are pulled from orbit by Daedalus, and can sometimes pose a risk to worlds in the system. There are several large asteroids which have uses as monitoring stations (Adrastus), mining (Pirithous, Dia) or military purposes (Lycomedes). Each are small, measuring no more than 1,000 km or so in diameter and shaped like potatoes.

Ariadne - Ariadne is a cold world with a dense, though toxic atmosphere. It has very little water; what ice exists is in the form of frozen methane and ammonia. Some primitive microbial life exists here. A small science station is on Ariadne to study these protozoa. Ariadne is orbited by a single moon, Phaidra.

Medea - This is a lifeless, rocky chunk with no value.

Hecale - Hecale has a thin ring system and numerous small moons, a lovely but lifeless rock.

Pallas - This is a small gas giant, with several moons and rings. Pallas' atmosphere, which is primarily hydrogen and ammonia, is banded in bluish shades, with a huge, dark storm of indigo and violet.

Pasiphae - Pasiphae is a small world of frozen gases and some minerals, but nothing of value.

Oedipus - This is a large, frozen world with a dense atmosphere of methane, ammonia and carbon dioxide. A monitoring station, Creon, is located in the northern hemisphere. A penal colony, Jocasta Base, is also nearby.

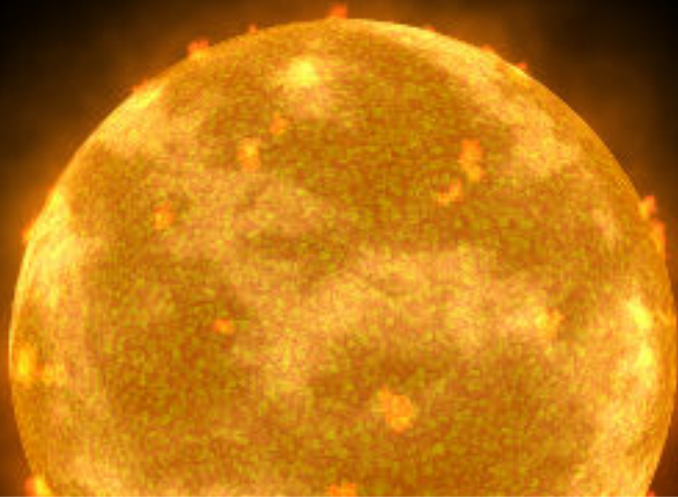

Theseus

Star Type: G1 V
 Stellar Radius: 6.99 x 105 km (1.01 Sol)
 Stellar Mass: 1.99 x 1030 kg (1.01 Sol)
 Stellar Temperature: 5,885 K (1.01 Sol)
 Luminosity: 3.92 x 1026 (1.02 Sol)

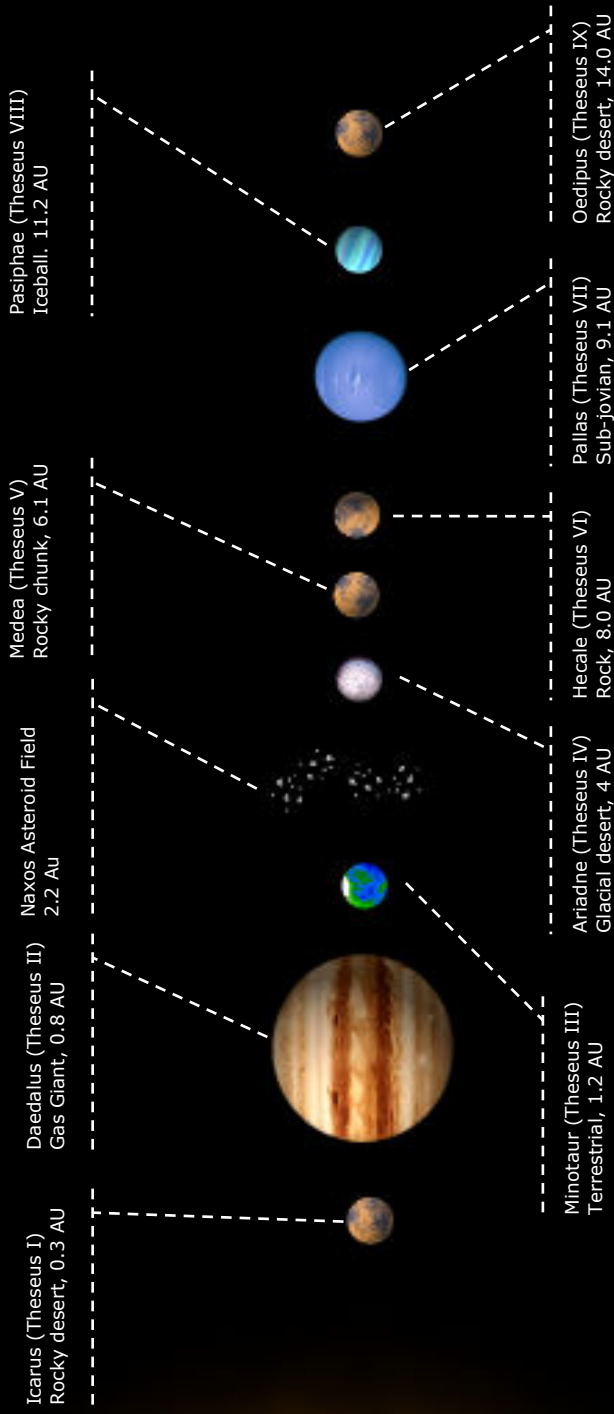

Minotaur (Theseus III)

Type: Terrestrial
Orbital Radius: 179,517,444 km (1.2 AU)
Local Year: 439 standard days (702 local days)
Local Day: 15 standard hours
Gravity: 1.2
Diameter: 13,000 km
Hydrosphere: 70% (0.22% Ice)
Atmosphere: 74% Nitrogen, 17% Oxygen, 2% Water Vapor, 1% Carbon Dioxide, trace others.
Climate: Cool, temperate, terrestrial. The largest biome is forest, especially coniferous. There are many lush, temperate rainforests.

Trade: Lumber and woodcraft are the major industries of Minotaur, though mining, smelting and various manufacturing industries are also prominent. Many different types of business are conducted on Minotaur, one such business is Starplay Enterprises whose headquarters is located downtown in the capital.

Government: Constitutional Oligarchy. The rulers of Minotaur are from the privileged class – the wealthy nobility – though they are somewhat restricted in their power by a Constitution which provides for all members of society.

Population: 8.6 billion (90% human, 10% other)

Notes: There are three main continents on Minotaur – Aethra, Aegeus and Asterion – with numerous large islands. The largest continent, Asterion, was shattered by a massive meteor impact hundreds of years before colonization, which has left a broken landscape and a series of large inland seas. In the center of the Labyrinth Sea is a great island, upon which sits the city of Maze. Athena, a fortified space station keeps the world safe. Wildlife is abundant here, most notable among with are the bloodsucking ptithic, the filter feeding golossan, the dangerous Cya's raptor and the spectacular shape-shifting Aktion's chimera. All of these creatures are kept to special preserves though incidents with citizens do occur.

FRONTIER CREATURES

By Allen Trussell

KAR'TIX HAG-XIN'S FIELD GUIDE TO FRONTIER CREATURES, VOLUME I

By Allen Trussell

In 100 fy, the UPF commissioned a reference work detailing known creatures of the Frontier. Led by Dr. Kar'tix Xag-Xin of the Vrusk Institute of Xenotics on Kawdl-Kit, this encyclopedia has compiled data of all known flora and fauna, natural and engineered, found throughout the Frontier. Presented here is an excerpt from that collection.

Aktion's Chimera

Type	Large Omnivore
Number	1
Move	Medium (50 meters/turn)
IM/RS	5/50
Stamina	120
Attack	80
Damage	2d10 bite, 1d10 claws (x2), 1d10 sting
Special Attack	Poison, assimilation
Special Defense	Shapeshifting, assimilation
Native World	Minotaur, any climate

Description: In its natural form, Aktion's chimera is a 3 meter long, pink-violet mass of undifferentiated flesh. The creature is able to shift its form into anything that roughly matches its volume; from simple stones to other creatures (an INT check against a score of 90 will reveal the deception). When in combat, a chimera will create an array of natural weapons - piercing teeth, slashing claws and a powerful stinger, all of which carry its poison (S 10/T 5) - which it will use to incapacitate or kill prey, but its most terrifying ability is assimilation. When the chimera defeats a creature, it shifts into its natural form and engulfs it prey, which soon becomes a part of the chimera. A living creature assimilated has 3 turns to escape (current STR against a score of 100) before it becomes forever a part of the creature. Through assimilation, Aktion's chimeras can learn and use some abilities of prey creatures, such as flight, swimming, water-breathing, burrowing and the like. Because of its basic amorphous nature, a chimera can squeeze its body through small openings or crevices, though this typically gives away its true nature. If reduced to half its STA, a chimera will shift into a mode of movement best suited to escape.

Bakkato

Type	Medium Omnivore
Number	1-12
Move	Medium (60 meters/turn)
IM/RS	6/60
Stamina	70
Attack	85
Damage	1d6 bite, 1d4 claw, or by weapon
Special Attack	none
Special Defense	Glide
Native World	Hakosoar, forest

Description: This is a primitive simian-like mammal native to Hakosoar that bears a striking similarity to yazirians, even to wing membranes. They are, however, of no genetic relation to the yazirians, and are marsupials; their young are carried in a pouch on the abdomen. Bakkato have gray-green fur, short tails and large fangs; the males sport red and yellow marks on their snouts. Bakkato live in trees, feeding on fruits and small animals they can catch. Like yazirians, they can glide from tree to tree using their wing membranes. They are primitive, but cunning enough to use simple clubs or other implements in a club-like manner. Bakkato only fight creatures larger than themselves to defend territory or family, but will flee an obviously superior foe. They are most dangerous when cornered.

Chameleon Snake

Type	Small Carnivore
Number	1
Move	Fast (100 meters/turn)
IM/RS	8/75
Stamina	10
Attack	40
Damage	1d4 bite + poison
Special Attack	none
Special Defense	Color-changing scales
Native World	Gran Quivera, forests

Description: This viper grows up to 1 meter in length, but is very difficult to spot due to its ability to blend in with its surroundings. While a chameleon snake stays still, it can only be spotted with a successful INT check (against a score of 85). Chameleon snakes use their camouflage for both hunting and hiding, and will strike from a hidden position in attack or defense.

The poison of the chameleon snake is very potent. When bitten, a character must succeed a current STA check or be affected by a S 10/T5 poison. Even with success, the character still takes 5 damage from the poison in addition to the bite damage.

Cya's Raptor

Type	Small Carnivore
Number	1-6
Move	Fast (90 meters/turn)
IM/RS	9/90
Stamina	60
Attack	80
Damage	1d8 bite
Special Attack	Mimicry
Special Defense	Mimicry
Native World	Minotaur, forest and jungle

Description: A small, brilliantly plumed bird of prey, Cya's raptor is a cunning creature, and has the ability to mimic a variety of sounds. The favored tactic of Cya's raptor is to mimic the cry of its prey's young, tricking prey into believing an infant is in danger. This mimicry is nearly perfect (an INT check against a score of 120 to detect the difference), and can be that of any creature which makes a vocalization. Cya's raptors will also use this ability in defense, making enemies think a larger predator is approaching, or otherwise confusing foes.

Drape Moss

Type	Small Omnivore
Number	1 patch
Move	Very Slow (5 meters/turn)
IM/RS	2/20
Stamina	15
Attack	none
Damage	1 point/turn
Special Attack	Incidental attack, entangling, poison
Special Defense	Regeneration, entangling, camouflage
Native World	Morgaine's World, forests

Description: A mass of stringy filaments hanging from the branches of trees, off-white and moist, this fungal life-form feeds on whatever happens to get caught within it. Anything flying, crawling, walking or simply floating into the mass of drape moss gets held fast (current RS check to avoid entanglement) and slowly consumed. The drape moss filaments inject a mild toxin (S2/T10) into living prey (current STA to avoid) to aid digestion.

Drape moss is difficult to differentiate from other, harmless forest growths of similar appearance. A successful Analyze Sample (or Exobiology) use check (score of 50) or an INT check (score 65) will reveal the nature of this hazard.

Any sort of melee attack drape moss results in weapon entanglement (as above), rendering it immune to needlers and most non-energy weapons. Likewise, its loose filament structure allows most ballistics to simply pass harmlessly though, though grenades are effective (as they tend to become entangled). Drape moss is extremely vulnerable to heat and fire, taking double damage (this includes lasers and masers). Drape moss regenerates 5 STA per turn until reduced to 0 or less. Drape moss can move, but only does so to escape damage or find more plentiful food.

Erengal (Groth Siren)

Type	Medium Carnivore
Number	1-4
Move	Medium (50 meters/turn)
IM/RS	8/80
Stamina	80
Attack	70
Damage	1d10 bite, 1d4 claws (x2)
Special Attack	Captivating song
Special Defense	none
Native World	Groth, oceans

Description: An aquatic creature, the erengal has a vaguely humanoid appearance, with a spiny, eye-stalked head atop a torso with two arms, and a fish-like tail for legs. Its color ranges from green-brown to pink-gray. From a distance, the creature can be mistaken for a swimmer, but its piscine nature becomes quickly evident upon closer inspection. Groth sirens would be easily avoided if it were not for their sonic capabilities; an erengal can emit a sound that other creatures find irresistible (a LOG check against a score of 80 avoids), which draws the prey to the erengal to be devoured. This ability is usable above or below water to a range of 120 meters.

Golossan

Type	Giant Omnivore
Number	1
Move	Very slow (10 meters/turn)
IM/RS	1/10
Stamina	250
Attack	none
Damage	none
Special Attack	Engulf
Special Defense	Exhalation
Native World	Minotaur, any sky

Description: A pale bluish-gray to silvery-white creature, this appears to be nothing more than a gargantuan flying ray. Upon close inspection, it can be seen that the golossan has a cylindrical center mass, some 15 meters in length, with "wings" of gossamer-like filaments extending out to 20 meters on each side. The front of the creature is a gaping maw, filled with fine strands which filter smaller food from the air. This is anything smaller than 3 meters in height, or 5 meters wide (medium creatures or smaller). Once inside the golossan, death usually results from suffocation (current STA/ turn to avoid), as air taken in is pushed out of the stomach cavity. As a defense, the golossan can exhale a vast quantity of air, powerful enough to knock most flying objects or creatures out of the way (STR check against a score of 150 to stay aloft), generally sending such flying some 100 meters away. It can exhale once every 3 turns.

The game mechanic presented in this article uses target numbers as follows:

$$d100 + \text{ability} \geq \text{target score}$$

For instance, "STR check against a score of 150". The character rolls d100 and adds his STR, if he is equal to or greater than 150 the check succeeds.

Keddith

Type	Large Carnivore
Number	1-4
Move	Medium (60 meters/turn)
IM/RS	6/60
Stamina	100
Attack	70
Damage	3d10 bite
Special Attack	Pounce, 2d10 claw rake (x2)
Special Defense	none
Native World	Morgaine's World, plains and savannah

Description: Keddiths are large, flightless predatory birds. A keddith stands some 4 meters in height, with a long neck and a sharp, hooked beak. Its two long, powerful legs have 25cm long sickle-shaped talons just above the foot, which it uses to tear at its prey. Its body is round and compact, with two small arms bearing small grasping claws which hang slightly forward. The female keddith's plumage is a dull mottled grey-brown, while the males sport a bright red crest, and red and black tail display. With its powerful legs a keddith can run down and pounce on prey, leaping up to 90 meters and making a raking attack with its razor sharp foot talons. Keddiths typically try to incapacitate prey before feeding, but will fight to the death if threatened or cornered.

Ptithic

Type	Small Carnivore
Number	1-10
Move	Medium (50 meters/turn)
IM/RS	3/30
Stamina	50
Attack	60
Damage	1d4 + drain
Special Attack	Numbing toxin
Special Defense	none
Native World	Minotaur, any habitat

Description: This insectoid terror looks much like any mantis-like creature found on numerous worlds. It grows up to 30 cm in length, and is flightless, though it does possess small, vestigial wings. Ptithics are found in a variety of climates, with matching coloration, from green to brown to yellow. All varieties of ptithic feed on other creatures to survive, but they usually go only for prey their own size. During the mating season, however, this insect requires something more potent, and this is when ptithics can become dangerous.

The ptithic requires a compound found in cerebrospinal fluid to propagate their larvae; they will approach any creature with a high supply. Their bite has a numbing toxin (current STA to notice a bite) which allows the insect to bite and feed without interruption. Once a victim is successfully bitten, the ptithic will feed, draining 5 INT per turn for 1d6 turns. This lost INT will return on its own as the body replenishes itself at the rate of 1 INT per day.

A successful First Aid check (or Medical Treatment: Wounds I) will restore 10 INT instantly, and 5 INT per day. The numbing toxin of the ptithic is a useful component in making staydose and doze grenades;

harvesting it from the ptithic requires a Minor Surgery (or Biology) skill check to retrieve 1 dose (worth 1 Cr).

"Hey Sarg, did you see this?"

"See what?" inquired the FAST veteran combat medic.

"This new memo from the quartermaster."

The veteran soldier craned his neck and read allowed, "Warning, the humma have demonstrated immunity to ptithic poison leading to complication with medicines derived from this source. Of particular concern is the demonstrated ineffectiveness of the life saving drug staydose. All medics are advised to begin stocking staydoseHVi, SynthCorp's new synthetic staydose."

"Yeah I saw that but truth be told regular staydose is only 20% effective on them so if you aint got any of SynthCorp's fancy new synthetics just hit a humma with five regular staydose. 'Course if staydose is in short supply you can always roll the dice by shooting a humma with 1 or 2 shots and see if it will take effect. This memo is just a bit of scare marketing by your friendly neighborhood mega-corp angling for a fat government contract."

"Oh," said the private

- » Staydoes HVi costs 10 credits/dose. A small 5 pack case that easily snaps onto a utility belt costs 60 credits.
- » FAST is Land Fleet's Forward Aid Station and Triage group.

Tevnarl (Morgaine's Lion)

Type	Large Carnivore
Number	1-2
Move	Medium (45 meters/turn)
IM/RS	5/50
Stamina	180
Attack	70
Damage	4d10 bite, 3d10 claws (x2)
Special Attack	none
Special Defense	none
Native World	Morgaine's World, plains

Description: This great beast can grow up to 4.5 meters in length, and up to 1,200 kg. It sports a spotted brown and tan coat; its jaws have two 15 cm fangs, and sharp claws are on its four feet. A tevnarl's overall appearance suggest a huge lion/bear hybrid, or perhaps large smilodon.

Tevnarls are cunning predators, and are intelligent enough to know when to flee. They go for the easiest prey – the sick, the weak and the slow. Named for Admiral Morgaine, these hunters use expert tactics, and prefer to disable prey waiting for death or exhaustion to set in before feeding. Morgaine's lions fiercely defend themselves if retreat is impossible. Attempts have been made at domestication, but the beasts have proven to be too cunning to be reliably trained, even when raised from cubs.



BACKGROUND MATERIAL

» **Editor's Note:** I'm very excited about the work Victor is doing. He logged on the Star Frontiers development site, poked around a bit and created the **STAR FRONTIERS (URS)** project. Victor has put together a variant d20 rule set for the Star Frontiers setting which includes over 50 races and multiple worlds.

[<http://www.starfrontiers.us/node/4345>]

UPF AGENCIES

By Victor Gil de Rubio

Aside from Star Law the UPF has created several government agencies to handle certain common problems which stem from governing such a large amount of territory. The success of these agencies has long been questioned, but they are the best that the UPF can create, limited by the amount of influence they can exert on the sovereign rights of each inhabited planet in the Frontier.

LEAGUE OF AMBASSADORS (LA)

The League of Ambassadors is a government agency created after the First Sathar War in an effort to use diplomacy whenever possible when dealing with races that are not members of the UPF. Lately though the League has had its mandate broadened to allow them to serve as go-betweens between member races in an effort to avoid escalating a conflict.

The League of Ambassadors' duties often involve any negotiation between planetary and interstellar societies and the UPF. They are also mandated to oversee any first-contact negotiations, which puts them at odds with the Frontier Office of Survey and Statistics.

THE COLONIAL AFFAIRS COMMITTEE (CAC)

This government agency handles matters pertaining to the colonization of planets. Any authorized colony in the Frontier has at least one small office where a representative from the CAC works. The Colonial Affairs Committee's job is to insure that the regulations set out in the Frontier charter are observed in regards to any new colony. These rules generally amount to guidelines regarding the sovereignty of higher life-forms encountered on planets. In the event of a first contact situation occurring, the CAC officer must notify the LA office closest to the colony world, and has the authority to establish first contact rules with the new species until a LA representative arrives.

The CAC officer has the right to take over the management of a colony in the case of an emergency, or if the colonial government is found violating Frontier guidelines, but may only control the colony until he is relieved by a new colonial government agent, or a representative from a mega-corp if the colony is owned by a mega-corp.

FRONTIER OFFICE OF SURVEY AND STATISTICS

The Frontier Office of Survey and Statistics is mandated to survey the worlds of the Frontier and to keep accurate records of all worlds in the Frontier. The Exploration Service (ES) is charged with exploring the known Frontier and what lies beyond the Frontier. The exploration division has the authority to certify worlds for colonization, and can make detailed observations about new species encountered and recommend how the LA should approach a first contact situation.

UPF TRADE COMMISSION

In response to the growing number of aggressive Mega-Corps, the UPF has created a government agency whose responsibilities is to set tariffs, duties, rules and regulations for all merchant ships in the Frontier, whether they are corporate or independent. All merchants must be licensed by the UPFTC in order to work in the Frontier. However, the UPFTC has no authority in the Rim, and many merchants who cannot pay the high tariffs have started to move to the Rim.

At present UPFTC depends on Star Law to enforce its policies, and their constantly trying to convince the UPF that if they had their own enforcement arm, it would free up Star Law resources. At present, though, their requests have met with refusal. UPFTC operates many customs houses throughout the Frontier. Depending on the population of a star system this can either be a small office with 2-5 customs officers or can be large building employing hundreds and operating large warehouses and impound lots.

FRONTIER TRADE ADMINISTRATION (FTA)

While the UPFTC oversees the operations of merchant ships throughout the Frontier, the FTA oversees corporate practices, and is a judicial branch of government authorized to fine or otherwise punishes corporations who do not follow fair trade standards. The FTA has only been in operation for two decades but its power has, on more than one occasion, been felt by mega-corps who have been caught participating in illegal activities such as selling junk bonds, or participating in "ice wars".

UPF POSTAL SERVICE

The Frontier is huge and getting messages from one planet to another is vital to maintaining the Federation. The UPFPS or just the PS as it is often called is in charge of interstellar communications. The PS maintains a fleet of courier type ships that make mail runs throughout the Frontier, but they often contract privately owned merchant ships, or purchase space on corporate owned star craft, to deliver correspondence, and packages throughout the known Frontier.

THE WARMASTER'S GUILD

The Warmaster's Guild was an independently operated guild which ran a registry for mercenary companies in the Frontier. Eventually, the guild received a license from the UPF and the Rim Coalition. The Warmaster's guild is responsible for assuring that mercenary companies follow strict guidelines regarding the terms of war, the treatment of captives, and what weapons are outlawed by the UPF and Rim Coalition. To insure that licensed mercenary groups obey the regulations, the WG often assigns company overseers to travel along with mercenary companies to hotspots. These overseers often act as go-betweens and diplomats, but may defend themselves as needed. The WG also maintain a standing military force, in case a situation gets out of hand they have to be called in to resolve a matter. ★

ADVENTURE CONCEPTS

By Thomas Verreault/jedion357

COLONY SHIP LOST

The SS Ark left Earth 178 years ago with 10,000 colonists in cryo as well as 1,000s of species of animals and plants. Something has gone wrong as she has not arrived at her destination and her command crew is dead. The robotic brain nicknamed Hal, has selected and revived a new command crew from among the colonist. While he cannot explain much about what has happened he is insistent that they must take over and fulfill the mission.

The new command crew begins to suspect something might be wrong but they are confronted with a myriad of repairs and minor emergencies. As they start to investigate numerous questions present which are tough to answer. Why is there a 45 meter hole in the hull? Why are a number of other people missing from their cryo beds? Why is one of the heavy lift shuttles missing? Why did the ship by pass a suitable planet that would sustain human life? Where did the mysterious sample of alien DNA in the med lab come from? Why is equipment suddenly breaking down now that we've decided to turn around and check out the planet? Did Hal just change the ship's course on us? Just what did happen to Hal's memory banks and is he trying to kill us now?

RECYCLED PCS

Recycle those old player characters! Dust off your copy of **Star Frontiersman #3** and turn to page 10 for the article "Fleshing Out Your Character". In the article is a table with effects of aging. Take those old player characters and advance them to old age or even ancient, applying all effects as per the article. One player should volunteer for his character to have become overweight or even obese and another for his character to have become skinny and frail and all those effects are applied as well. Then give them their probable income for the intervening time period as well as some more experience to simulate the character's development during the past decades. Each player will have to write up a blurb detailing what the character has been doing since the group last adventured together. The caveat is that none of the characters can do anything TOO exciting during those years.

Now the set up is that for some reason, possibly the death of an old NPC acquaintance they have all gathered for the wake and funeral. Naturally enough they begin to reminisce and tell tall tales but fate takes a hand and they're about to have one last hurrah back in the saddle again. Just what exactly killed their old friend? Is there an enemy they never dealt with? Does anyone out there still remember their old exploits? How high are the stakes against them? Will they go out with a bang or will they eventually die in their beds?

BEHIND ENEMY LINES

It's the first Sathar War and the planet Pale has been ravaged. Pockets of resistance hold out here and there and the Presidency has fallen to the Speaker of the Senate. The PCs come from a variety of backgrounds; police, local militia, security, etc and are trapped behind enemy lines in a partially destroyed city. Can they fight their way through to Free Pale Forces?

After the escape to non-sathar controlled territory they are recruited for special operations behind enemy lines. As the sathar space fleets drive on to Cassidine and Dixon's Star the planet Pale falls further behind enemy lines but its citizens are not about to roll over and die. The new president, Sarah Homles is determined to strike back and rescue captured citizens from sathar detention centers, destroy supply depots, and take back Pale for all Palonites. These goals require dedicated small special operation teams who can sneak behind enemy lines and strike back against the tyranny of the Sathar.

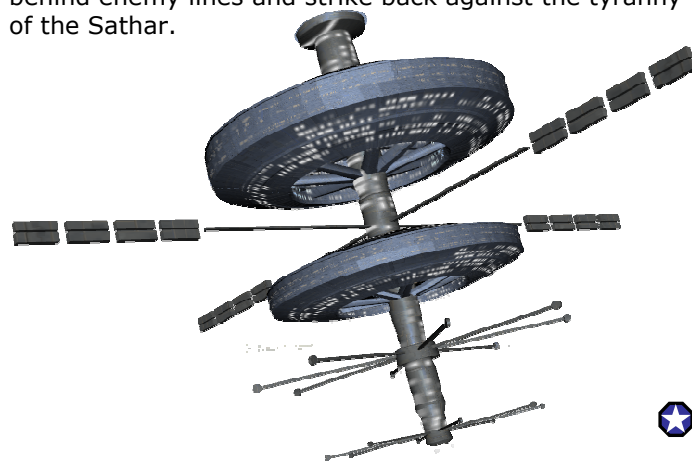



SRM 2010

Dyscola® won't freeze in the black of space. Guaranteed!

DATA SEARCHES ON THE WHITE LIGHT SYSTEM

By Thomas Verreault/jedion357

Author's Note: In the System Brief for SFKH0 "Warriors of White Light" module, there are several agents of unrest who are opposed to the planetary government. They were listed as the Political Party, Liberation Front, and pirates. There was the suggestion of connections between the terrorist and the pirates with possible corporate support from Streeel Corporation. All of this information fills two small paragraphs in the system brief.

Visitors to the White Light system, most likely tourist, might not have considered the facts presented in Warriors of White List to be of any special interest. Others may have been keenly interested in them. Anyone motivated to look deeper into the agents of unrest may have found the following in their data searches on GalactipediaNET.

SEARCH Liberation Party, Clarion

RESULTS The Liberation Party had as its major platform plank the abolition of the monarchy. For decades it had been part of the opposition parties on Clarion. In the aftermath of the assassination of King Leotus XIX it was discovered that the Liberation Party was little more than the political arm and mouth piece of the terrorist group the Liberation Front. A backlash of public sentiment ended the Liberation Party functionality as a viable political party. In the aftermath of the assassination many former Liberation Party members joined the small Liberal Party.

SEARCH Liberal Party, Clarion

RESULTS The Liberal Party has grown in power and influence over the past few decades since the assassination of King Leotus XIX. In the aftermath of that event some of the key members of the Liberation Party brought their amassed funds and joined the Liberal Party. Overtime it became to new political home of the anti-monarchist. There are still some "classic liberals" in the party but they no longer represent the party's leadership.

In recent years the party has positioned itself as the champion of the poor and managed to stake out a pivotal role in Parliament. With the loss of the majority support in Parliament for the Queen's close political ally and Prime Minister, Lord John Enoch, the Liberal Party became the key to maintaining the majority that kept him in charge of the government. In exchange they were given a seat in the cabinet. The Ministry of Defense is now controlled by Lady Hilda Slike. Analysts believe the coalition government formed by the Crown Loyalist, Conservative Association, and Liberal parties will not last because their political ideologies are diametrically apposed. For now the leader of the Liberal Party, Lord Jonnas Slike, often

"releases members to vote their conscience"; which is political speak for go along with the Queen and Prime Minister on parliamentary votes while he publically opposes the Queen and Prime Minister.

SEARCH Lady Hilda Slike

RESULTS Lady Hilda Slike, Baroness of Oil Flatts and Minister of Defense. Began her political career as an aid for her cousin Lord Jonnas Slike when he as a prominent supporter of the Liberation Party. She was elevated to baroness after the destruction of the Liberation Party and has been an avowed liberal ever since.

During the most recent fight in parliament to maintain Lord John Enoch as Prime Minister the Liberal Party lent support to the Prime Minister in exchange for a seat on his cabinet. As the cousin of Lord Jonnas Slike the new leader of the Liberal Party it was a forgone conclusion that she would get the cabinet seat.

Her administration of the Ministry of Defense has been marked by controversy. Her liberal ideologies have led to resignations by key members of the Royal Guard and Royal Marines, including one Lord Commander. Ideological concerns led to a firestorm over the naming of the latest ship in the Royal Marine order of battle. As a stipulation for signing off on the purchase of the ship she required an unprecedented break with tradition. Normally all Royal Marine assault scouts are named for birds of prey but the latest ship was christened as a medical ship and named Nightingale in keeping with the Minister's ideologies.

SEARCH Major political parties, Clarion

RESULTS The **Crown Loyalist Party** is largely made up of the aristocracy. Their core belief is that a strong monarchy guarantees their continued position in the political structure of the planet. This party is obviously a strong supporter of the monarchy.

The **Conservative Association** has adherents in the House of Lords and the House of Commons. They typically abhor changes and measures that would lead to higher taxes. They have traditionally supported the Crown due to its policies of low income tax and strong defense.

The **Socialist Party** is strongest in the House of Commons. It favors social reforms with its major belief being that the government must look after the citizens for their own good. Traditionally this party has been an opposition party.

The **Independent Party** is a small but vocal force in both houses of Parliament with a long tradition of opposition to the Crown.

New Beings Party often sells its votes to the highest bidder. Their major ideological concern is maintaining their power. They have many ideological sympathies with the Liberal and Socialist parties.

The **Liberal Party** has emerged as the spiritual home for the anti monarchist since the destruction of the

Liberation Party. Though traditionally an opposition party it has joined the recent coalition government of Prime Minister Lord John Enoch.

SEARCH Liberation Front

RESULTS The Liberation Front was the action arm of the Liberation Party and responsible for the assassination of King Leotus XIX. It continues to be active on Clarion but since the loss of its political mouthpiece the movement has floundered some. This has given rise to a radical element known as the Guards of Clarion.

SEARCH Guards of Clarion

RESULTS The Guards of Clarion are a radical and violent arm of the Liberation Front and supports the violent overthrow of the monarchy. It is known for its virulent hatred of the Royal Guards, Royal Marines and the Royal Mounted Constabulary.

Typical tactics include bombing and assassination attempts by armed groups. They famously bombed the Raptor's Roost night club in Port Royal, a known Royal Marine haunt.

SEARCH Royal Mounted Constabulary

RESULTS The Royal Mounted Constabulary dates back to the founding of the monarchy. It has served the role of a planet wide "federal" police force since its establishment. In the early days they kept the peace over large areas of Clarion that were sparsely populated and used live mounts to do so.

As the planet has grown to be a heavily populated world the methods of the RMC have grown and evolved to meet changing needs including the introduction of the first robotic steeds in the Frontier. Today you will find some areas of Clarion are still patrolled by "Mounties" on live and robotic mounts. RMC is a modern police force every bit the equal to the Star Law Rangers. Its motto, "Fidelitas, Veneratis, Virtus" translates loyalty, honor, and valor.



Editor's Note: GalactipediaNET is a great resource for campaigns as a type of Frontier news network, dropping clues and knowledge to the players. The information may be useful in degrees during a campaign. It's like the modern day Internet - full of useful and sometimes useless information. Information may allude to an upcoming encounter or inform them of their past actions they have been involved in.

GalactipediaNET gives the Frontier a "living" feel.

NEW CADRES AND CULTS

By Thomas Verreault/jedion357

Just because you can never have too many protagonists!

THE UNIVERSAL FAMILY MOVEMENT

The Universal Family Movement or UFM started as a dissident movement objecting to the despotic control of the Family of One. Under the leadership of theologians like Stig Slayerian it adopted a philosophy embracing a pantheist view of the universe and welcomes all beings into its fold.

A core tenet is that the divine oneness of the universe is all and in all, therefore all beings are welcomed. In practice it seeks to promote ethical lifestyles, peace, and positive action in its adherents.

The movement is small and dominated by yazirians. Usually forming small cadres in major cities these groups are lead by a shepherd and the members are called the flock. Some cadres, having charismatic leaders take on a strong anti-Family of One tone and have been suspected of terrorist activity against the Family of One.

The Family of One has responded with calls for the arrest and execution of key members so that all flocks everywhere have instituted some security measures. Naturally enough, the proposed executions are illegal in the Frontier but no one doubts, if any of these shepherds fell into the Family of One's hands, what their fate would be.

The symbol of the Universal Family Movement is a small metal ring worn on a chain about the neck. The ring has bands of color to represent the core four races; green, gray, white and yellow.

THE GUARDS OF CLARION

The Guards of Clarion are a splinter group of the old Liberation Front on Clarion. While the Liberation Front has lost some of its credibility, the Guards of Clarion have become rabid in their anti-monarchy rhetoric. They advocate direct and brutal action against symbols of the monarchy believing that this will awaken the rest of the population to overthrow the government. They are especially virulent in their hatred of the Royal Marines, the Royal Guard and the Royal Mounted Constabulary.

A typical attack by the GoC begins with the committing of atrocities against representatives of the crown and is usually followed by bombing the site of the attack. Recent intelligence discovered by the Mounties suggests that the next wave of attacks will involve a

double bombing. After the initial bombing a second bomb will be held in reserve to target the first responders.

Currently there is no known symbol for this group as little is known about them and the Mounties are not publically publishing their files on the GOC.

CLAN RENEGADE

Though the modern Clan Renegade claims descent from the historic yazirian fighting unit, this claim is probably spurious. Star Law believes the modern Clan Renegade to be an ultra secret but fully modern movement that plays on the conspiracy theories surrounding the demise of the historic military unit. What is certain is that the modern Clan Renegade advocated violence against the structure of the Family of One but not the outright destruction of its religious beliefs. This is an important distinction since the membership is assumed to be all yazirian. This cadre hates the leadership of the dominate yazirian religion even as many of its members may still believe in that religion. All members of this cadre are believed to have sworn Blood Enemy against the clan controlling the Family of One.

The historic emblems of the classic fighting unit are all used by the modern Clan Renegade. They also have a catch phrase or slogan, "Remember the Charge." This is a reference to the classic poem, 'Charge of Clan Renegade' but is also carries the double meaning of remembering the charge they have been given against the Family of One. 

A FIST FULL OF RUMORS

By Thomas Verreault/jedion357

Presented below is a d100 list of general rumors. They, for the most part, are based off a specific detail of the Star Frontier's setting. Some are correct, some are a little misrepresenting, and some are just there for flavor. Generic rumors could be used instead of a campaign specific rumor if a Referee decides the player characters haven't quite done enough to get the campaign specific rumor. By still providing a rumor it keeps them thinking about collecting clues from non-player characters.

d100 Result

01	Yazirian females often battle rage during labor.
02	Ifshnits won't deal with you unless you recognize them as honest and respectable merchants. Sociologists believe that it's related to their small size.
03	Streel founded the New Streel system to break into the agro market.
04	The Eorna have advanced phycho-tech; they can even wipe your brain.
05	"My buddy, Bo-Jack hooked a raffleur up to a power backpack and blew his whole arm right off!"
06	Osakar like to mix politics and religion.
07	If you're ever in a knife fight with a humma its not

what he's holding in his hands that you have to worry about but what he's holding with his tail.

- | | |
|----|---|
| 08 | Since Trans Travel emerged as a mega corp, PGC flagged ships have cut way back on service. You might think you're getting a deal but you'll pay 25% more on in-flight amenities. Trans Travel is really the way to go. |
| 09 | Gollywog brand crustacean sauce is relabeled as Clarion's Call Fire Sauce for sale in the White Light System. A smart being will rip the label with the Gollywog brand name off his bottle if he visits Clarion. |
| 10 | A hydra absorbs laser energy. |
| 11 | Decades ago a prized vrusk statue was lost with a ship traveling to Zebulon system; they say that today it would be worth.... |
| 12 | Yazirian's didn't always follow the Family of One. |
| 13 | Yazirians say that, "Hentz Hots Sauce, will put a fire in mouth, heat in your belly, and rage in your soul," however, it's not even from the hottest pepper known in the Frontier, very nearly but not quite the hottest. |
| 14 | The 'Triad Trounce' is a club and bar crawl through that planet's red light districts that leaves you broke, bruised and unable to remember everything that happened. |
| 15 | It's not wise to ask too many questions on Outer Reach. |
| 16 | The Ring Runners were fairly successful smugglers in Fromeltar till the militia stamped them out. |
| 17 | I heard that some of the Ring Runners escaped to Zik-Kit were they continue to operate a smuggling ring. |
| 18 | Photographing government installations on Morgaine's World can get you arrested. |
| 19 | I heard that the civil service draft on Pale applies to anyone who's lived there for a standard year or longer. |
| 20 | A tech from the AV lab says that the footage of the vrusk CEO of MINER who was executed by kidnapers is a fake. |
| 21 | Capitol University, Pale is actually a for profit college owned by Streel. |
| 22 | Because of constant police actions and fiscal shortages the government of Pale is, for all intents and purposes, wholly owned by Streel. |
| 23 | Vrusk Atlas often provides elite cartographers for exploration expeditions in exchange for exclusive rights to produce the atlas. |
| 24 | You need a pressure suit to reach the top of Mt. Spire on Lossend. |
| 25 | Unauthorized persons who travel to Ringar in Solar Major are never heard from again. |
| 26 | "Psst, I know a dral that can sell you the astro data for the jump route to Ebony Eyes." |
| 27 | There's a lot of military surplus left in stock pile on Laco after the corporate war. |
| 28 | SynthCorp has been working on hormone laced food that can make you more desirable to the opposite sex. |
| 29 | Interplanetary Industries has a patent on a new generator that produces energy from gravity but cut a deal with AIPS to milk the Frontier over energy costs. |
| 30 | The Marilyn Cybernetics Cortex robot, model N23, was recalled last year. It is prone to a malfunction that causes the robot to flip out and kill people. |
| 31 | The Silver Death Cult is building a planet buster ship to crash into Mechano. |
| 32 | J. Harrington Farnsworth, who leads the Anti-Sartharian League, is funding exploration expeditions to discover sathar space. |
| 33 | They say Jack Lagrange is not dead; it's the only explanation for his group, the KLC, being Frontier wide now. |
| 34 | When GODco terraforms a planet they often wipe out |

- indigenous species; some say its part of their master plan to recreate the galaxy in their own image.
- 35** The city of Maze on Minotaur is the number one sin city in the Frontier; ANY form of entertainment is just about legal and available there.
- 36** I heard that Pale was considering out-sourcing its militia to ForceCo.
- 37** Can you believe that Star Law made 'Rimmers' agents?
- 38** The UPF has been looking into unmanned drones to replace fightercraft.
- 39** Ral'Ik'Ka is the vrusk trade house that provides security for vrusk trade houses Frontier wide but they tend to hire only vrusk.
- 30** There was this dralasite who poisoned himself trying to smuggle a weapon inside his body.
- 41** There is lost alien tech on Laco that PGC doesn't want anyone to know about.
- 42** Some say the Tetrarchs played a part in the evolution of the original core four settlers of the Frontier.
- 43** The sathar are drawn to black holes.
- 44** The monarch of Gollywog is a sathar agent.
- 45** The CEO of GODco is a pederast.
- 46** PGC has mummies of the Tetrarchs on their secret planet, Exodus.
- 47** The Royal Marines of Gollywog never take prisoners.
- 48** The UPF should step in and set up a proper democracy on Clarion and get rid of its archaic monarchy. We're a galactic civilization for space's sake and we allow a monarchy to persist?
- 49** The council of trade houses on Terledrom is planning to boycott Madderly's Star over their anti-vrusk policies.
- 50** A yazirian mother was convicted for indecency because she was breast feeding her pups in public at Madderly's Star. Since she's now classified as a sex offender, her pups have been made wards of the government.
- 51** Malco found an ancient starship on one of the moons around Outer Reach. I heard he has some secret weapon that no one knows about.
- 52** Star Play's resort station in K'tza-Kar is haunted.
- 53** Star Law can now tap into your advanced chronocom.
- 54** Look out for the red 'rage dose' it's suppose to be contaminated.
- 55** Malco just developed an artificial formula Ixiol!
- 56** There's a rich ifshnit looking to hire big game hunters to capture some of the dinosaur like creatures on New Pale.
- 57** I heard a vrusk pilot discovered something drifting in deep space that the Family of One won't want brought to light.
- 58** Trans Travel's starliner, the Titan, is said to take luxury beyond imagination.
- 59** Astronomers predict that Balley's Comet will strike Hargut in the next 40 years.
- 60** The zethra are really sathar agents traveling the Frontier and gathering information.
- 61** The best chefs in know space are on Osak in Rim Space.
- 62** The planet Groth in Fromeltar produces some of the best dralasite cooks.
- 63** Counting cards at Star Buckaroos can get you killed on Dark World station.
- 64** There is evidence of the sathar visiting Gran Quivera centuries before it was colonized.
- 65** Eating Gollywog brand crustacean sauce can prevent space herpes.
- 66** I know a dral with the map to Hatzck Naar's treasure.
- 67** People are five times more likely to get sick booking passage on PGC starliners.
- 68** Samo Vox is going to win Frontier Idol.
- 69** You didn't get this from me but bet on Minxx in the

- ninth.
- 70** The Cast Iron Stomach award is a joke; a humma wins every year.
- 71** The sathar can control the formation of a black hole.
- 72** If your yazirian tri-barrel gyrojet rifle isn't from War Tech then it's likely to jam on you in combat.
- 73** The Family of One is considering expelling the osakar that have joined.
- 74** The executives at Steel made huge bonuses last year despite the down turn in the economy.
- 75** Did you see the holo news on PGC; they're being investigated by Star Law over payoffs in exchange for Space Fleet contracts.
- 76** The Vrusk Mutual Aid Society was robbed but only computer records were taken.
- 77** The saurian refugees are planning to settle on watery worlds and build underwater cities.
- 78** Scientists believe that Vrusk Soft Shell Syndrome is linked to a virus.
- 79** The drought on Rupert's Hole is driving up costs of agro exports.
- 80** The Red Devil is still out there committing piracy.
- 81** The Zenk, the vrusk crime syndicate, has deep ties into Star Play and many of the resort stations in the Frontier.
- 82** Having an organic computer implanted is a good way to let the government hack into your mind.
- 83** Hey, you want to score some accelerator drug?
- 84** There's a rare brain parasite the will confer mentalist powers; it's true, I read it on the info nets.
- 85** The local spa has real imported Alcazzar mud for its mud baths.
- 86** The Blue Plague was created by the sathar.
- 87** The Blue Plague was created by a mega corp.
- 88** The UPF's new power armor is susceptible to EMP damage despite what the manufacturer says.
- 89** If you ever visit Faire in the Capella system, be sure to take a submarine tour, they're well worth it.
- 90** You can get a great deal for a sunny beach vacation time share on Clarion!
- 91** Be on the look out for scam artist offering vacation time shares on Clarion.
- 92** Med students have been illegally selling cadaver brains to robotics firms for cybots and the brains haven't been fully wiped of the prior owner's personality and memories. These people end up waking up imprisoned in a robot's body.
- 93** Galactic Task Force requires organ donation certificates from all employees.
- 94** Voltturnus crystals will be the next generation of power conductors and computer memory matrix devices.
- 95** Voltturnian burrower snake poison can cure obesity.
- 96** The government on Zdikit, Madderly's Star, dug up all the vrusk graves after the Free World Rebellion and dumped the bodies in the bay.
- 97** The new strain of genetically engineered horses on Clarion is immune to hoof rot.
- 98** Obesity is the third leading cause of death in dralasites.
- 99** The contractors at the ships yards over Rupert's Hole have been using sub standard building material in their radiation shielding leading to high incidence of sterility in starship engineers.
- 100** There is a recall on Eversafe's latest model of spacesuit armor.

Editor's Note: If you do not use the races from Zebulon's Guide to Frontier Space simply replace the race names with organizations. For example, **02**; "Free Traders Union won't deal with you unless you recognize them as honest and respectable merchants."

CIVIL SERVICE ORGANIZATIONS IN STAR FRONTIERS

By Matthew Crymble

Author's Note: What about civil service organizations in a space dwelling society? They definitely exist in canon SF materials with Star Law being the most talked about and fleshed out. But certainly there are others such as Spacefleet, PSA (Planetary Survey Administration mentioned in the Module SFKH2 & Dragon #105) and likely a few others I've missed. But the absence of a wealth of information on these organizations makes a great opportunity for anyone who wants to run a fun campaign where players are simple civil servants doing a job and saving the galaxy... day to day anyway.

There would certainly have to be a several civil service organizations existing in the Frontier with a few being obvious background material. I'll explore three in depth here....

BOSS - Bureau of Standards and Statistics

One of the most overlooked agencies at work in the Frontier, but one of the most omnipresent and critical as well. Who decides the safety standards of atomic engines on starships? BOSS does. Who determines the minimum square meters and available amenities for the multi species staterooms on passenger liners? BOSS does. Just how pathogen free does blue milk need to be before it can be on Frontier shelves? BOSS has a standard for that too. With so many species living together there has to be a happy medium of standards, which BOSS is charged with determining and keeping updated. Products across the Frontier carry the BOSS seal whenever they conform to these standards, which make them the most relied upon products purchased today. (Few spacers buy non BOSS approved spacesuits for instance.)

FPS - Frontier Postal Service

Without a doubt, the Frontier would cease to function without the FPS's daily workings. While most of the FPS's "mail" is transmitted via subspace as data only, there is still a need to move small packages and the occasional actual "letter" (a tiny data cube or other high tech memory storage device). Each UPF member world has FPS transmission stations on it that are federal property and both exempt and impartial to that individual world's government. So while offworld "mail" transmissions are handled by FPS, movement of mail from the actual transmission site (or a regional post office) to citizen's homes are handled by the local world's information infrastructure or local delivery service (both paid for by local taxes). However, UPF citizens can still go to any post office directly and collect mail or give small packages for transit. They can even have a post office box if they want to

circumvent the local system. This ensures a limit to local government's control over the mail system as well as a check and balance to insure continued communication in a local crisis.

FPS does maintain a small fleet of courier ships and fast freighters for important runs and routes for package mail, but most common runs are contracted out to commercial freight services as highly sought after government contracts. Note that interfering with a postal carrier in his appointed rounds is a serious offence and is a good way to get investigated by Star Law or a similarly empowered (for mail related offences only) Postal Inspector.

PSA - Planetary Survey Administration

Mentioned in both the module "Mutiny on Eleanor Moraes" and the Dragon article "Expanding the Frontier" the PSA is a civil service agency charged with continued survey and exploration of the unclaimed worlds both within and outside of the Frontier. PSA accomplishes its charter through several different methods. The first is it works closely with Spacefleet in cataloging and charting hazards to space navigation within the Frontier, resulting in continually updated starcharts and navigational tables. It also charters exploration missions to unexplored, or less than completely explored worlds.

The PSA's main function is to act as a funding agency and to direct exploration efforts more than it is to actually carry out these missions directly. This means that PCs with useful skills or their own ship can often find contract work for the PSA.

CIVIL SERVICE AS BACKGROUND IN A STAR FRONTIERS CAMPAIGN

Civil service organizations could simply be background material for flavor in a campaign or could actually be employers or adversaries for the PCs. Here are some examples of fun tidbits that can be included in a campaign.

- » *You've gotten a great deal on a case of Incendiary grenades for your next mission. You're sure that while they don't carry the BOSS seal, they should be perfectly safe to carry across the landscape of an alien world.*
- » *Now that you know the Malthar's secret, you have to get off that station alive with the information. Ids men will be watching all the docking bays, but maybe you can get a message out via subspace. The Post Office is 6 levels down from where you are now... if you think you can make it.*
- » *You've successfully completed your mission with just a few bumps in the road. Your employer is happy and you have even received a small bonus. Of course, you have to wonder if Star Law will be keeping a file on you after this one...*

» *It is infuriating that you have come light years out here on an absolutely golden PSA exploration contract only to be stymied by a maintenance problem on your ship. Now that the engineer has identified the problem, you realize you should not have bargained so hard at the shipyard for those repairs. To save credits, they used non BOSS certified parts. Of course your engineer is confident that she can jury rig a repair if she has something to work with and there's an old abandoned colony on the southern continent. Better land and get working or else you're going to be stuck here for a very long time. You're sure the stories about that old colony are just stories after all...*

STAR FRONTIERS CIVIL SERVICE CAMPAIGNS

Of course you do not need to simply use Civil Service organizations as campaign background. They can be the focus of the entire campaign as well. Here are a few ideas for referees to draw from.

PSA Contract Supply Runs: While the PSA does outfit Spacefleet vessels for missions such as the famous UPFS Eleanor Moraes, it also gives lucrative contracts for adventurers with their own spacecraft to run missions or provide support for their teams. A fast PC freighter, assault scout, or privateer would be a favored platform for this type of mission. Missions could be a dropping off a survey team and then returning later, dropping off supplies to a remote science base, or even a rescue mission to a team that has run into trouble.

» *Adventure Hook: You've come back to pick up the science team here on LV427 only to find them... Gone! There are definitely signs of a struggle all around the colony but few bodies. You won't get paid unless you at least bring back a good explanation, so you had better look around before you leave.*

PSA Exploration Missions: A full system survey is the most involved adventure type (see the Dragon article "[Expanding the Frontier](#)") but it could be a more straightforward groundside adventure using Alpha Dawn rules. The first Volturnus survey mission is a good example as is Mission to Alcazzar.

» *Adventure Hook: This seemed like such an easy mission just a few weeks ago. Cataloging mineral survey samples in the local mountain range and looking for the prime site to mine. That was until you ran across the much larger and better armed Zuraqqor scouting team, no doubt here for similar purposes. Now it is a cat and mouse game until your relief shows up. There are some old [Clikk](#) ruins that your team accidentally discovered to the east. You might be able to find some shelter there, assuming you can survive any defenses still functioning after all these years*

Colony Postmen: New colonies need postal service more than most, and Postmen hold a special place in these communities. But making sure the mail goes out can be more of a challenge on some worlds than others. PCs hiring on as Postal Inspectors at a tiny postal station have to fend off the dangerous creatures that might destroy their subspace radio. They also must maintain the lines of communication on the planet itself because of the lack of a central government. This could lead to all kinds of adventures across the face of a mysterious world. But where else can you deliver the mail in a fully armored explorer?

» *Adventure Hook: The Halstead's wildcat mining operation has received a big load of offworld supplies this time. But their last communiqué puts them past the recommended settlement territories agreed upon with the Eorna and dangerously close to the Mounds of the Mechanons. Better load up the Explorer and get this over with, the last thing you want is a Mechanon warbot showing up to parley. Just another day here at Volturnus Postal Station #1.*

BOSS Industrial Espionage Campaign: Being an Inspector for BOSS means being part engineer and part investigator. Robotics and cybernetics especially are governed by strict Frontier laws when you move into the fields of Artificial Intelligence and Cyber Body Enhancement due to their inherent dangers if left unchecked. Powerful megacorps are always trying to push the envelope and make profits, not always in ways that are good for the Frontier. But they always try to keep the BOSS inspectors happy, until those inspectors find out something that will cost them a lot of credits. Then they have a choice to make.

» *Adventure Hook: You are WAY off the reservation on this one. A little nighttime inspection of a remote research facility has turned up a lot of information. Dangerous information. Dangerous to you if these cyber thugs catch you before you can report back. Curse them for jamming your chronocom signals so quickly or this would already be over. Now you have to escape to a public terminal and get the word out... before they kill you for what you know.*



LAAMVIN

By parriah
(Jess Carver)

ALIEN CULTURE UPDATE FILE
Zeb.828300af-2

LAAMVIN

PHYSICAL APPEARANCE AND STRUCTURE

Laamvin are a pseudo-crustacean intelligent species native to a desert planet similar to Volturnus. They are furry and approximately one meter tall. They are trilaterally symmetrical, and covered in a carapace much harder than a Vrusk's. In fact it is nearly as hard and unyielding as a clam's shell. There are three major limbs arranged equidistantly around the carapace. These limbs, or "legs" branch into three more limbs, or "arms", about half way down, that then terminate in three deft fingered hands which are also used as the main means of locomotion. There are also three similarly arranged golden colored eyes with lids. The mouth is located at the peak in the center of the being. These mouths consist of three equally sized mandibles lined with triangular teeth.

SENSES

Laamvin have keen scent facilities and can see slightly higher into the IR and slightly less deep into the UV than Humans. They are not bothered by bright lights. They have nictating membranes that cover their eyes protecting them from bright flashes. Due to the equally spaced eyes set around the body, laamvin are able to see 360 degrees making them extremely hard to surprise.

SPEECH

Laamvin speak exactly the same way humans do, but because of their dentition they have very odd accents in any language spoken in the Frontier. They have a high aptitude in language comprehension and gain a +20 bonus during first contact when attempting to communicate.

SOCIETY AND CUSTOMS

As mentioned earlier Laamvin culture is a highly developed society and has technology roughly analogous to Victorian England. They have an elected Parliament, with 3 major parties. The Royals (three of them) are the head of the government and can veto any legislation, but cannot issue dictates. They can suggest bills to MP's but those MP's are not compelled to follow up on these suggestions by law. Their Majesties have the power to declare war, but there is no major civilized opponent on their planet to require war anymore, because all previous civilizations are now integrated into one.



The Laamvin culture is concentrated on one continent. But there are roving bands of savage vicious nomadic barbarians out in the desert.

Laamvin have steam powered trains, firearms which can repeat fire roughly the equivalent of 3 shot Colt pistols and single shot trapdoor like rifles. They call the pistols Reciprocators. Frontier races would do well not to attempt to fire these weapons because they are extremely powerful and will likely break bones and cause strains, sprains, and ligament tears. They also still use swords, maces, hammers and almost anything

that will bash a carapace. The desert tribes use the equivalent of flint lock muzzle loaders and heavy crossbows. These are designed to penetrate Laamvin carapaces and would likely punch cleanly through any of the Frontier races.

Laamvin culture enjoys the extreme dryness of the desert. This is due to the fact that Laamvin shells are softened and eventually dissolve when exposed to water. If the exposure is extreme enough, the shell will rot off, killing the Laamvin. Water is not unknown; most cities are built next to a river or coast, because of ease of transport. The Laamvin do need to drink water, but not much as most moisture needs are taken care of in their diet. Their diet consists mostly of the fruits and flowers of the same plants from which their homes are built, and a rodent like creature native to the deserts of their planet.

Laamvin culture resembles the Victorian era of England. There is a dominant middle class, also numerically superior, that has a strong sexual code of conduct. This is based on the tri lateral sexuality.

The Laamvin have 3 sexes; Fertilizers, Egg Layers and Nurturers. They are all three required to participate in the procreative act. They are referred to as he she and hre, him, her and hrim. The nurturers are protected and held in high esteem by the other sexes and are not allowed to walk outside alone or be alone with members of other sexes who are not members of hrer immediate family, etc.. The Fertilizers take the dominant role in society, being the laborers, fighters, policemen, etc. The Fertilizers are considered protectors and providers. The middle classes believe in sporting chance, chivalry, fair play, etc. Any display going against this code will be viewed with much disfavor.

The lower classes pay lip service to the middle class mores, but do not generally comply with it except when in the presence of their "betters". There is no nobility, except the extensive royal family, but there are privileged members of society. They include Bankers, highly successful businessmen, high ranking members of the military (which can be earned by merit as well as birth), politicians, etc.

Laamvin homes are structures made of a fibrous cactus-like plant that yields wood-like boards that can be built with. These structures are extremely flammable. This has led to the rise of a professional fire fighting corps with a long history predating written records. The fire fighters are known as Their Majesty's Bucketees. These are considered a part of the military, but do not fight in wars. Bucketees fight fires with bucket brigade lines of beings using the plentiful sand of the environment on their planet.

The Bucketees have a class of investigators, think Sherlock Holmes types, who started out as arson investigators, arson being a capital crime, but have evolved over time to become more like a modern police detective and investigate most serious crimes like murder, embezzlement, robbery, etc.

Laamvin become intoxicated by receiving mild doses of electricity. This practice is frowned upon by the "proper" middle class, but they too indulge, just in secret. There are parties and flop houses created simply to "do juice". There is a thriving business in it and if a middle class businessman can be proven to have derived any income from it, he will be shunned by proper society. Politician's careers have been ruined simply from rumors of current use or a connection with juice houses.

ATTITUDES

Laamvin believe that there are three forces that control everything in the universe. Where humans see hot or cold, the Laamvin see hot, cold and an in-between something like cool/warm. There is no equivalent word in any Frontier language. Light and dark are equally divided into light dark and dim/mild. There are three descriptive of everything. The Laamvin will react well to any Frontier race as long as they do not exhibit boorish or poor sporting behavior. Prominent displays avaricious greed or rudeness will not be tolerated.

SPECIAL ABILITIES

360 degree vision Because of the location of the Laamvin's eyes they have all-around-vision cannot be surprised. Laamvin automatically win initiative.

① Typical Laamvin

STR/STA	45/70
DEX/RS	45/60
INT/LOG	45/45
PER/LDR	45/45
Punching Score	3
Initiative Modifier	6
Movement	
Walk / Run / Hourly	20 / 45 / 8km

CREATIVE REFEREEING

By Thomas Verreault/
jedion357

STRATEGIES TO ENCOURAGE PLAYERS IN CREATING PLOT HOOK LADEN BACKGROUNDS

By Thomas Verreault/jedion357

Game mastering is like relationships. After you've been through a few you have your, "been there, done that and got the T shirt to prove" stories. Relationships that worked out and others that didn't, some that were horrible and others that leave you with a warm fuzzy glow when you ponder them; they come in all shapes and sizes. Campaigns and gaming groups are very much like this: some shined, others died with a whimper, and some just blew the doors off.

I've game mastered table top and online RPGs from a variety of games and rule systems. When I was a teenager, I never stopped to consider my GMing technique or why a game was fun, or why a particular adventure was exciting. I suppose it's symptomatic of aging, I've become introspective. Time is short and demands on it are high, so if a group falls apart or a campaign dries up I want to know why. Consequently, I also quiz myself to understand why something was successful. Ultimately, I hope I can learn from my mistakes and duplicate my successes before I hang up my dice.

I've been pondering some developments in one campaign that have stood out over nearly every other campaign I've run. In one online campaign nearly every player has written a character background that has elements that beg me as the GM to use them as plot hooks. At the same time, I have a table top game that lacks this depth of character in the character backgrounds and some of the players play in both games! The comparison and contrast between the two is so sharp that it cannot be by chance. So what happened, or rather what went right in the online game? In analyzing what was done in each campaign, I've come up with some strategies that could help a game master encourage his gaming group to write great plot hooks into their character's backgrounds.

In the online game I offered 1 experience point each for writing a background, a description, and coming up with a character portrait. Initially, I thought this exercise made the characters more grounded or more real to the players and to me. It doesn't really hold that offering a carrot to get someone to write a background will guarantee that they will write in plot hooks for the GM. Then I realized that for the online game I wrote up some setting background documents to familiarize the players with the setting I was planning to use. It was patently obvious that some of the players had read these and incorporated information from them in their character background.

For the table top game, the player characters were rolled up and thrown into the campaign with no background information on the setting. Thus the character backgrounds are general and adequate but they contain no glaring plot hooks. Those players simply never had the opportunity to write a plot hook laden background. They are experienced role players that I've observed using changes in tone, style, vocabulary and speed of speaking to nail a character. One of them is so good at this that you always know it's his character speaking when he talks to you in character, he never has to tell you he's in character. Would they not have pulled setting details together for their character background if they had had a document titled, "What the PCs Ought to Know about the Setting"? I believe so.

I have come to the conclusion that most players want to have a character well grounded in the setting. If a game master puts in the work of writing a one to two page background on the setting for the players, the effort will pay dividends in the player character backgrounds. It will not only give them a feeling for the tone of the campaign but provide them with meat for their backgrounds. Most players realize that the game master presents the adventure and the setting so they won't try to create the setting details; instead they get to explore the setting through the course of the game. However, if they have a page or outline of PC knowledge they will include some of that in the character they develop. The details they include can then be worked into the course of an adventure, for example a character who worked his uncle's asteroid mining ship before joining the military will always be the go to guy when the military unit deals with miners and prospectors and all things asteroid, all that is required is for the adventure to have asteroids figure largely in it and he's gained story share. Another example would be the player who writes his character's brother is a member of the terrorist group that is to be a major foil in the setting.

To create a setting background document don't bog the players with tons of information. Make it more like a bullet list; about the monarchy, about the cultist of the Red Death, about the last war, and so on. Endless paragraphs are tough to read so break up the document with short paragraphs and double spacing between them. Include some information on the groups that will be the antagonist in the campaign. Don't tell them everything though. What you don't tell them becomes content for the campaign.

The next strategy for encouraging plot hooks in the player character background is to require all players to write a secret about their character that only they and the game master know. This is a new idea that I'm using but not really that new idea to me. I had previously read a suggestion to give each major non-player character a secret and had been using that with some success. However, a player in the on line game suggested a secret about his character during character creation. It's a fabulous plot hook.

I now believe every player character should have a secret. As a game master, you don't have to use these secrets at all but they are there as potential energy, waiting to be used. Naturally you'll only get to use them once or twice and this is good lest the device becomes stale.

The weaving of a character secret into the adventure can make the campaign more memorable for the player. So what that the PC defeated the pirate fleet through stunning tactics and iron nerve, he also managed to rescue his brothers remains from pirate base and return them to their home planet so that his brother's spirit may rest in peace. Which will be of more importance to the player; killing yet another big bad pirate or resolving the mystery of his brother's fate?

Finally, the last strategy was discovered by chance as much as the "secret" strategy was. Require each player to write an NPC contact. The NPC contact is just someone they know in the setting that may or may not help them in an adventure with advice, clues or material. The NPC may also function as a plot hook. If after several campaigns the PC gets a message from the NPC to meet with him over an urgent matter and they discover his house or office ransacked and the NPC missing. How could the player not desire to help their "friend?"

This has become a favorite strategy of mine after using it in a Voltarnus campaign. I gave each player a little something extra and one of the players got an NPC contact that I wrote. The contact was of another race than the PC but had

always been like an uncle to him. The player used the contact to weasel a free gun from him which I allowed. However, the pirates recognized the gun and PC was to learn that it originally belonged to a traitorous member of the pirate band and the leader wanted him found and killed. Is the PC's uncle the traitor or did he obtain the gun another way? Is he in danger? Suddenly this contact has blossomed into all sorts of possibilities and is fodder for plot hooks and twists.

In the Alpha Dawn Remastered rules an optional rule on edges and flaws was included (ADR page 142). I have not used this but I think it would duplicate some of what I proposed above wrapped up in a game mechanic. In particular the flaws read like plot hooks. This could be another way of encouraging creativity on the part of the players.

To sum up: provide players with a background brief on the setting and or a document on PC baseline knowledge. Require them to create a secret about their character and to write an NPC. Be open to their questions and desires and use them as an opportunity to create depth and plot hooks in your campaign. Then let the fun begin. 

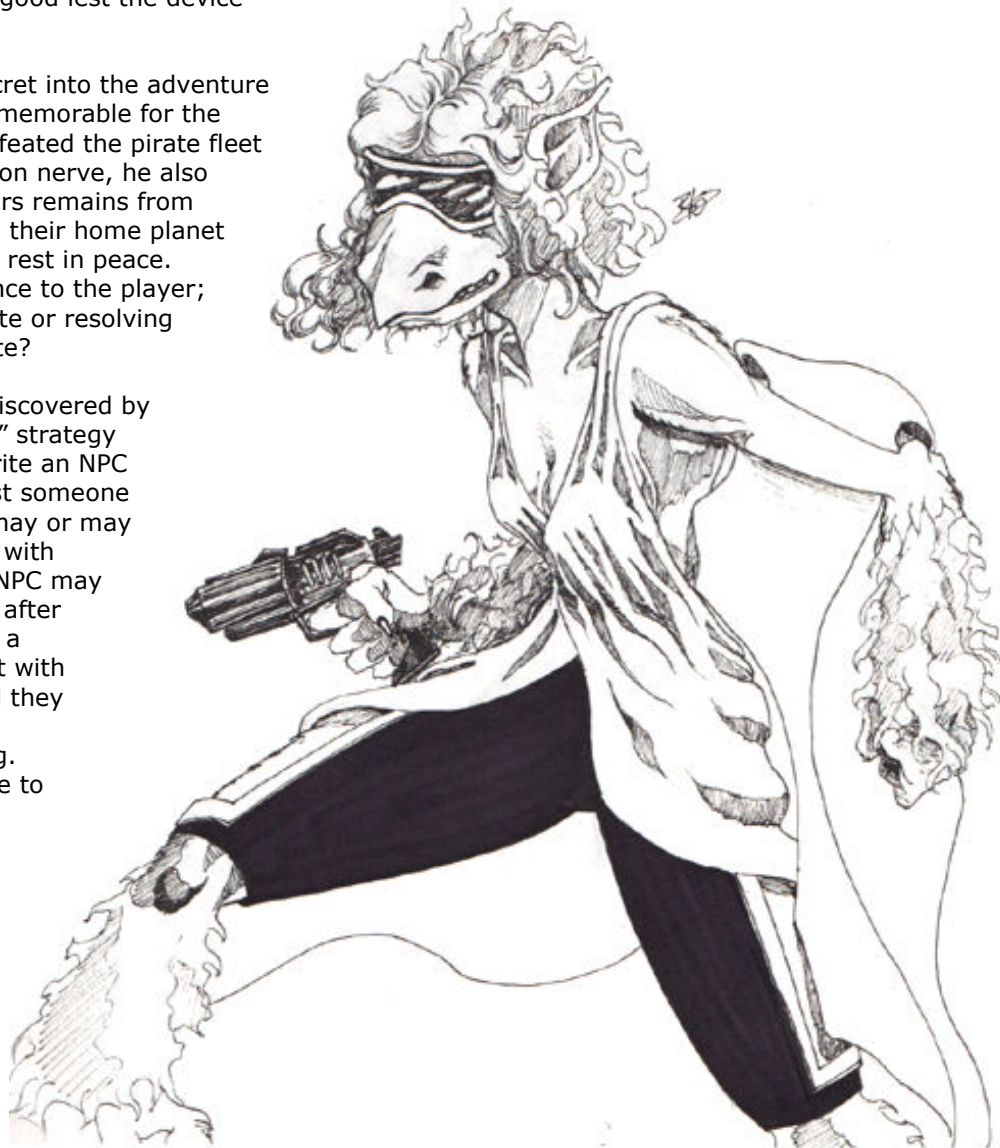

FRONTIER FICTION

DISCOVERY: PROLOGUE

By Tom Stephens

"Raptor, this is Dauntless," the radio crackled to life with the voice of the Dauntless's captain. "We've started to accelerate toward your position and will be engaging the dampening screen shortly." As he spoke, the monitors on the Raptor began to register the Dauntless's motion. "Try to hit us if you can," he added with a laugh.

"Copy that, Dauntless," came the good-natured reply from the Raptor's captain, "You can't beat the laws of physics, son, we'll nail you on the first shot."

This was to be the first full scale, real-world scenario test of the new Dauntless class scout ship. All other tests to date had been mocked and staged. This time, no one but the Dauntless knew what the planned maneuvers were to be. It was as much a test of the way the Raptors's weapon systems responded to the Dauntless's new engines as much as a test of the StarTech Dampening Field.

Everyone watched the tactical display as the Dauntless closed the distance. Light travel time was minimal, just a few tenths of a second between the ships, so the uncertainty band around the Dauntless's location was very small. Allison had to agree with the Raptor's captain, it was very unlikely that the Raptor's gunner would miss. There just wasn't anywhere for the Dauntless to go.

Dr. Allison Durrant was on board the JSS Raptor, the cruiser class ship in charge of the test, as an observer. An original member of the theoretical design team for the new defensive screen, she had been involved in the design of the Dampening Field system from the very beginning. After the design had been completed, she had transferred over to the engineering team that had actually built the system. Of everyone, she probably had the best working knowledge of how the thing was supposed to work, both in theory and in practice.

Just before the Dauntless entered the effective range of the Raptor's weapon, the radio came to life again. "Engaging the shield now." The tactical display showed the Dauntless turning, trying to add some uncertainty to it's direction vector just as it entered weapons range. And then it vanished, completely disappearing from the display.

"What the ...?" cried out the technician monitoring the video feed from the telescope trained on the Dauntless. There was stunned silence on the Raptor's bridge for a couple of heartbeats before pandemonium broke loose.

"Dauntless, this is Raptor, come in Dauntless," the captain started calling over the radio. "Dauntless, this is Raptor, do you copy? Over." Switching off the radio, he started asking questions and issuing orders. "Radar do you have anything?"

"Negative, sir, the screen is clear. One second she was there and the next she was gone. It doesn't even look like there is any debris."

"Crank the power up to maximum. I want a return on anything in that area," the captained ordered.

"Roger, sir. Commencing scan now."

The captain turned his attention to other areas. "Energy sensors, what have you got?"

"Nothing, sir. Same story here. We had a full spectrum read on Dauntless as she started to enter weapon range. We showed a brightening to one side as she maneuvered and exposed more of her engines. Then there was an intense flash of energy across the spectrum followed by the screen going dark. No residual energy of any sort, just empty space. We thought for a second the system malfunctioned but we ran a diagnostic and it checked out and we can see the Condor just fine."

"Same instructions for you," the captained ordered after hearing the report, "Go to maximum sensitivity and report on anything you find."

"Yes, sir."

It took Allison a little longer to respond to the sudden change of events as her mind was trying to process and analyze what she had seen. Like the telescope technician, she too had been watching the optical video feed from the Raptor's primary two meter telescope. It just somehow seemed more real to her than the tactical display with all its figures and statistics.

As the "Engaging the shield now" call had come in, she had seen Dauntless turn, main engines still blazing to put some cross field displacement into its velocity vector. That wasn't unusual, she'd seen that before in other tests. It was a typical combat move. She had seen the defensive shield spring into existence as it was activated by the Dauntless crew. It had a faint

light blue optical component that she had seen hundreds of times before in development tests.

And then something strange had happened. It was barely perceptible, but Allison had seen the field operate too many times and was sure she had seen it. As soon as the field sprang fully to life, it was streaked with deep violet ribbons. This held for the briefest instant and then it flashed blindingly bright. The monitor had saturated and Allison had blinked and turned away from the display to clear the bright light from her eyes. When she looked back, the Dauntless was gone. It had vanished from the image.

Her first thought was that there was an explosion. But then she would have expected to see debris of which there wasn't any. Her next thought was that the telescope has lost its tracking but that wasn't true either as the background starfield hadn't changed. There were only three stars visible and they were still exactly where they were before. The Dauntless seemed to have just vanished.

Which took her back to her first idea, but the Dauntless hadn't blown up. That much was certain from all the sensor readouts she could see around the room. Radar, energy sensors, optical and infrared telescopes were all cranked up to maximum sensitivity and magnification and were scouring the area of space where the Dauntless was last seen. There was literally nothing there. No ship, no debris, nothing. Everyone was working frantically, trying to get some sort of detection of anything by any means but it was becoming rapidly apparent that that Dauntless was gone.

She sat at her station on the bridge for a few more minutes as the Raptor's crew tried fruitlessly to raise or locate the Dauntless. As she watched the empty sensor scans continue to come in, her mind wandered back to what she had seen in the telescopic view. What has caused the modulation? Had there been any effects detected by the other sensors? What was different this time?

It wasn't long before she decided that there was nothing left to be gained by staying. It may have been a bit cynical, but all that was left was to gather up what sensor data they could and head home. She keyed her console to store all the data from all sensors for the time period corresponding to the vanishing of the Dauntless and make it available at her workstation in her cabin. With that she got up to head out the door before all the questions started that she, as the lead of the Dampening Field system team, couldn't answer. She needed time, and somewhere quiet, to think.

Just as she reached the door, she was stopped by a hand on her arm. It was the first officer. "Dr. Durrant, what ..." he started.

She cut him off. "I don't know what happened," she said, knowing what his question was. "I saw something but I need to think about this and look at the sensor data. And I need quiet. You guys are going

to be pretty busy up here for the next little while and I'll just be in the way. I'll be in my room working on this. Just make sure I have access to all the data." With that she pushed past him and left, taking the elevator down to her cabin.

It was a long trip back to Jord. As the expert on the defensive screen, everyone was looking to her for answers she just didn't have. As far as she could tell from the telemetry the Dauntless had been sending, everything had worked flawlessly, there was no indication of any sort of malfunction or anomaly. Everything was normal right up to the point where she had visually noticed the field modulation. Beyond that, silence. No data at all.

At least she knew the visual modulation she had seen was real. It was clearly visible in the slow motion playback of the telescope feed. The energy sensors also confirmed that something had happened. Directly correlated with the modulation she had seen there was a corresponding shift in the energy spectrum being emitted to a higher energy output by about a factor of two. Then it went off the charts for the briefest moment, a few microseconds at most before there was nothing.

She poured over the telemetry and sensor data almost non-stop on the trip back looking for clues. As far as she could tell, there was nothing in this test that hadn't been done before. It was during dinner one night about three days after the accident, when a casual comment by another engineer triggered an idea.

His job had been to monitor the performance of the Dauntless's new Enigma engines. He had commented about the energy field used by the engines to achieve their high efficiency. This sparked a thought when she realized that maybe some interaction of the two energy fields had had some unexpected effect. As far as she knew, nothing had been observed during tests near Jord but she was at a dead end everywhere else. And with her degree in quantum field theory, this was right up her alley. As her mind churned over the idea, she got more and more excited. It was all she could do not to just bolt from the mess hall and race back to her room and in the end she lost that battle.

Once there she had gotten right to work. The two systems had been designed and built by two completely different companies. Her company, StarTech, had built the Dampening Field. The new Enigma engines had been built by Double-E, Evanston Enterprises. They both used some cutting edge theoretical physics to achieve their desired results. As far as she knew there was never a study done on how they might interact. All that existed was data from the trials near Jord and the data from the disastrous test they had just witnessed. A quick query of the ship's computer confirmed that there was no such data on-board.

Next she fired off a pair of queries via radio to Jord to search the networks there. The first was to look for any information on studies of the two fields together.

She wasn't expecting that query to return any results but you never knew.

The second query was for any publications and data on the theory and operation of the field in the new drives. She knew the details of the actual implementation in the engines would not be available as that was proprietary information for Double-E. However, it was quite likely that the physical theory behind the implementation had been published in a scientific journal. That was actually what she was interested in anyway and there was a good chance of getting the information.

Because of their distance from the planet, it would be a few minutes at least before she got a response on her queries. While she waited, she pulled up the mathematics for the defensive shield theory and started to review them. After about twenty minutes, she got her query results back. As she suspected, no one had done any sort of theoretical analysis of the interaction of the two systems. This was not surprising since they were developed by different companies. And, as she hoped, the details of the theory behind the quantum field that made the engines work had been published. She pulled that data into her computer and settled back to read.

It was several hours later before she finished and she realized that she was both famished and tired. Looking at the clock, she realized that she had read through the night. "Not my most productive time of day," Allison thought to herself, "but at least now I know where to start." After a shower, breakfast and a short nap, Allison attacked the problem once again.

Adding the equations that described the engine's field to those of the defensive shield, she started to work out what effects they would have on each other when one was operating inside the other. It took most of the trip back to tease out the beginnings of a stable solution but by the time the Raptor docked, she was beginning to understand some of the possibilities. And if she was correct, the implications were staggering.

As she felt the Raptor begin to maneuver into its dock at the station, Allison stared at her monitor which showed the most probable solution. The answer was simply mind-boggling. She looked up, her gaze landing on the last image of the Dauntless which she had taped to her wall. "Where did you go?" She asked the image, "and did you survive the trip?"



DEMONS

By Thomas Verreault/jedion357

The CMS Osprey coasted through the Planaron Asteroid Field flanked by her sister ships Wasp and Falcon.

Delicately, Lieutenant Mike Bryson caressed the controls for the attitude thrusters bringing Osprey into the docking bay of the smashed Planaron Pirate Base. The pirate fleet had been dealt with but the base required clearing.

The CMS Leo, the militia's frigate, was heavily damaged while drawing the pirate fleet's fire allowing the assault scouts like the Osprey to swarm and in ripple salvo their assault rockets. Now for their sins and for having come through unscathed the smaller ships' crews would sweep the base.

The Osprey's bridge had an air of jubilation. The "Middies," or raw midshipman straight out of the academy on their first tour, could barely contain their excitement at winning a deep space battle. Bryson was grim remembering the carnage he had witnessed on a ship raided by these particular pirates, yet he didn't rain on the middies' parade. They had performed well and deserved to blow steam. Soon enough he'd get to settle up with the pirates and it would be his turn to be jubilant.

Keying the com he addressed the ship's engineer, "Chief, I'm not seeing any damage to the airlocks, we may not have to cut our way in."

"Yes Captain," Chief Warrant Officer Groon responded with the courtesy promotion he was always careful to use in front of the middies. "However, Midshipman Sennec will be disappointed about not getting to play with his explosives if we dock. Then again the airlocks could be booby trapped too...."

Lt. Bryson frowned, he knew they should blow their way in but that meant suiting up in pressure gear. Then again the Chief hadn't survived this long by being sloppy. Sennec would get to have his fun blowing open an air lock.

Each ship had sent over their entire compliment save one marine. This gave them three squad sized teams to cover three objectives. The Falcon's crew had secured the control center quickly, while Wasp's crew advanced toward the reactor, leaving Osprey's crew to sweep for survivors.

Lt. Bryson had led from the front all the while charging into combat like a demon. Groon was often hard pressed to keep up with him. He knew Bryson wasn't going to slow down till he exercised the demons he was carrying. The anger in him over Lt. Klast's death and Tabbe's betrayal had somehow become meshed with the anger over the rampant brutality of these pirates. The raided ships the Royal Marines had recovered with tortured and slaughtered crews had lit a fire in the hearts of the whole service but Bryson needed to punish someone.

At every combat he had charged in with his issue side arm and sonic sword. Somehow he'd not been hurt.



Groon had to run full bore to keep up with his friend. It was foolish but they had been through too much together and if they bought it, at least the middies were safely behind them.

The com crackled, "This is Wasp One, we've secured the fusion reactor but not without a fight. There is damage to the coolant feeds and the computer control files are scrambled. Be advised that it may go critical, over."

"Falcon One copies."

Groon watched Bryson eject a spent power clip from his laser before acknowledging for him, "Osprey Two copies," then switched to Bryson's channel, "Captain, we should pull back and leave any survivors to their fate. It's not likely that they'll get the fusion reactor under control and that means we'll have precious little time to pull out."

"Sure...what was that?" said the lieutenant and he was off and running down the corridor.

Groon swore before ordering Midshipman Senec to take the squad back to the Osprey and be prepared to move her away from the pirate base. He readied a tangler grenade to subdue the lieutenant and ran after him.

Groon sprinted ahead to the sound of combat. Entering the storage bay he saw two bodies on the floor and Lt. Bryson, helmet off, locked in a grapple with two

assailants forcing a vibro-knife to within centimeters of his face. A third assailant was drawing bead on him with a laser rifle from behind.

Groon threw the tangler grenade at the pirate with the rifle and scored a direct hit; its sticky thread enveloping him instantly. Activating his sonic knife, the dralasite warrant officer dove into the melee. Within seconds it was over and two marines stood there breathing hard.

"You had enough?" asked Groon.

"Yeah," responded Bryson with a sigh. "Let's get back to the ship before that reactor decides to go critical."

"Right, let's go."

They started to leave when a muffled cry reached their ears. Across the storage bay they discovered an improvised prison holding a human female. After what they had witnessed of this band of pirate's propensity for pillage, murder and rape; it was of little surprise that the prisoner a woman though it was surprising that she was still alive. Unfortunately, the deck plating was buckled and they could not get the cell door open. After rooting around Groon came up with a laser power torch and began cutting open the door. Bryson took off his glove and held the woman's hand through a narrow opening.

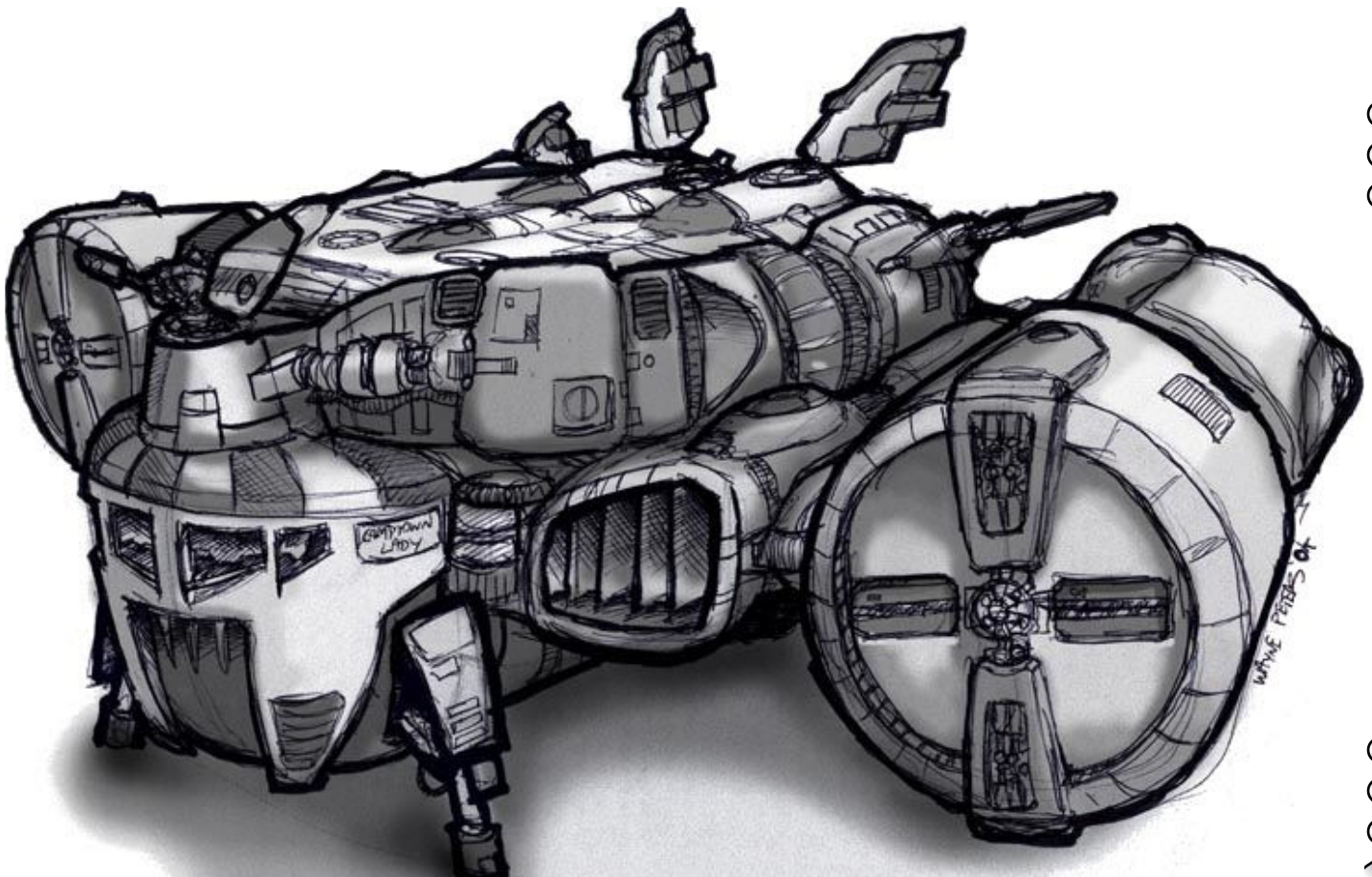

Groon was considering how to shorten the job when their chronocoms barked, "Wasp One to all squads, the reactor is going critical, you have ten minutes to get clear of the base! I say again, ten minutes to reactor explosion!"

The two friends looked at each other and Bryson asked, "How long to cut out the door?"

"Two, three minutes."

"Hurry, we can still make it."

Three minutes turned into four then five as the buckled deck plate stubbornly held the door. In the end, Groon had to cut access holes to cut through the hinges but then the woman was chained to a bed in her cell and that had to be cut. She had urged them to just leave her but Bryson was would have none of it.

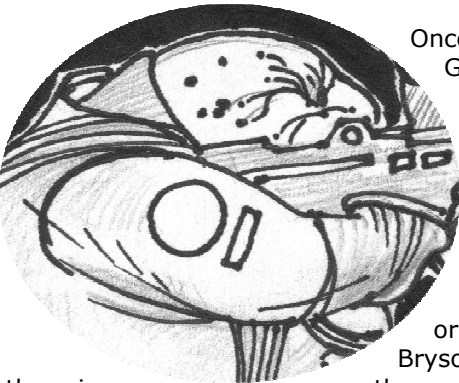

Once she was free, Groon commed Midshipman Sennec, "Sennec, move the Osprey away from base, we'll get off by another way. That's an order," but aside to Bryson he said, "If

there is another way off."

At that moment the entangled pirate spoke up, "I can get us off if you take me too."

The look on the female captive's face told Lt. Bryson all he needed to know about this particular pirate. He took out a vial of solvaway that would melt the tangler threads and held it aloft. The woman turned away.

"Tell me how and I'll give you this vial."

"No, free me first and I lead you."

"No you'll tell me and on my honor as a Royal Marine I'll give you the vial."

Beads of sweat stood out on the pirates face then he gave in, "Fifteen meters down that corridor is a ladder down one level to the captain's runabout."

Bryson held the vial a bit higher, "What's the security pass word?"

"Moon Runner."

"Alrighty then, here's your vial," said Bryson as he tucked it into the pirate's mouth. "I never said I'd actually free you but you may be able to bite down on the vial and spit the contents on the threads to free yourself."

The trapped pirate turned red with rage. He tried to shout curses around the vial that would free him and wound up spitting it out on the floor. His curses

eventually turned to pleas and he was still pleading when the reactor blew.

The runabout made it off Planaron Base with seconds to spare. Its view port's self polarizing film darkening out the bright flash just before the ship was rocked by a shock wave of plasma.

"That's going to remove some paint," quipped Groon.

"I've been thinking to resign my commission and get out of the Marines," announce Bryson. "My heart just isn't in it since we discovered the truth about Tabbe and the cover up."

Groon just nodded at his friend and fellow officer.

The two former Royal Marines sat in a hot tub each taking intoxicants according to their own physiology, it had become a tradition with them.

"So how does it feel to be the conquering hero?"

"Not half as good as it feels to be out of the marines."

"Did you ever get with that girl?"

"Naw, she still has demons enough to deal with from what she went through."

"Huh, we'll have to find work eventually, now that we're out."

"I just want to get comfortably drunk for awhile." Bryson nudged Groon and pointed with his chin. A short bald man with a scruffy beard was talking to the bar tender who pointed at the hot tub. They watched as the old man approached but kept silent.

At the tub the old man said, "Hello, I'm Garlus Tylapper, I'm looking for a crew for my ship the Gullwind and I hear you're recently out of the Royal Marines and top notch spacers...."



VEHICLES

By Gary Cliff / BD Cerridwen
Georgie

Author's Note: I recently had a conversation with someone concerning military helicopters and got curious about the V-22 Osprey. While researching it, I realized that it would make a great shuttle for SF! It's a little bigger than canon HS1 and smaller than typical HS2, so I classify it as a Super HS1.

UPF METEOR CLASS ASSAULT SHUTTLE

Hull Size: Super 1
(Length 19m (folded) or 18m (unfolded), width 4.6m (folded) or 25.8m (unfolded w/rotors), height 5.5m)

Classification: Shuttle (military grade)

Engines: 1 Atomic Drive, Sub-Class A

ADF / MR: 2 / 4

Hull Points: 12

DCR: 24

Weapons: None. (See description below)

Defenses: Military grade ceramic armor plating

Sensors: RADAR, Portholes

Communications: Videocom, Intercom, Radio-phone, ¼ power WNB

Hatches: 1

Minimum Crew Requirements: Pilot 1

Cost: Civilian: 462,280 Military: 665,280

Description: The Meteor Class Assault Shuttle is the workhorse of military organizations throughout the Frontier. Originally created by the CDC for use by its exploration teams, its design is like the modern day V-22 Osprey, with the space saving folding wing and tilt rotor atmospheric system. This system gives a top atmospheric speed of 600 km/h and a cruising speed of 450 km/h. It is completely VTOL (Vertical TakeOff and Landing) capable, combining the aspects of the aircar and jetcopter into a single machine.

The difference is, of course, that the Meteor has a small atomic space-drive, sub-class A, capable of boosting the craft into orbit, or decelerating it out of orbit. Due to space limitations and the shielding required to protect the

crew and passengers, this drive limits the Meteor to ADF 2. (Which is just as well since passengers are seated sideways in relation to direction of thrust). On terrestrial bodies with low gravity and/or little atmosphere, thrust is completely accomplished using this small atomic engine. During entry into a planet's atmosphere, the wings must be in the folded position while the atomic drive is used to slow the ship to under 200 km/h. There, the wing can be safely unfolded, locked in, and the atmospheric drive system takes over. To boost off of a planet's surface, the atmospheric drive will lift it to the altitude of roughly 8km (depending on the atmosphere's quality) before it transitions back to using the atomic drive to escape gravity. This allows it to be safely used even on densely populated planets. The Meteor's floor must be removed every 100 days of use in order to replace the insuit like material used to shield the passengers and crew from the atomic drive's radiation. The material costs 5000 credits and the job takes 12 man hours of labor to accomplish.

The Meteor is outfitted with the latest ceramic armor, giving it excellent heat resistance during re-entry as well as high survivability in combat. The ship is typically unarmed, but there are mount points for heavy weapons at the starboard side hatch, the port side forward cargo porthole, and the rear cargo ramp. These can be remotely operated using the Installation Security program. A weapon mounted at the port side porthole will displace a seat position.

The Meteor has crew positions for two pilots, each with controls configurable for piloting, astrogation, and engineering duties. It is kitted out with a full range of sensors and jamming gear, including FLIR, heat suppression (IR jamming), white noise generator (¼ power), radar chaff dispensers, night vision, etc. The cargo cabin is 1.7m high and wide and 5m long. It has fold-away seating

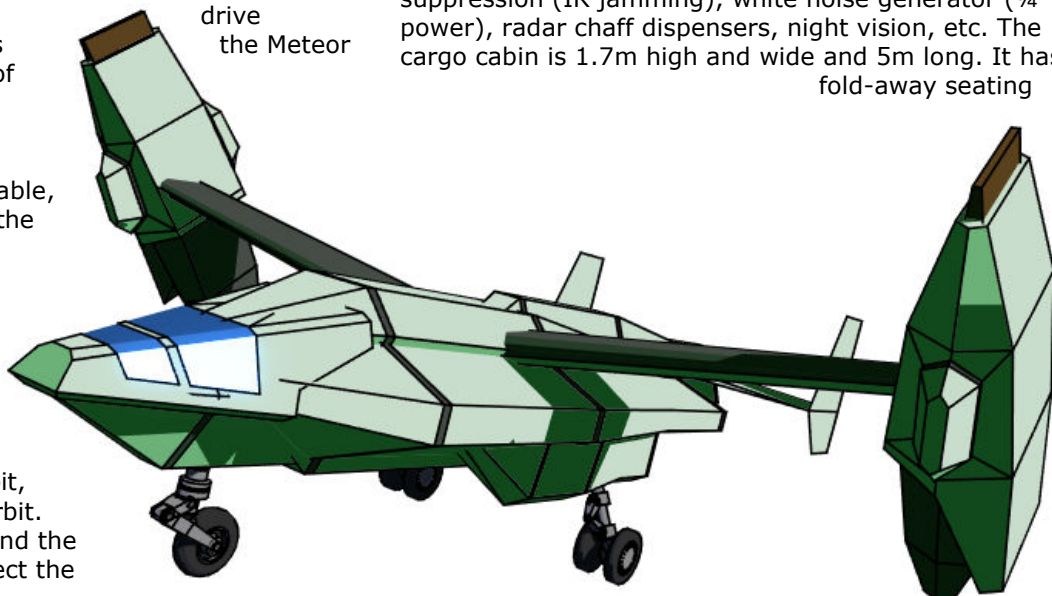

with 4-point harnesses for 24 humanoid passengers or 12 Vrusk. With the seats folded up, there is space for a small ground car, cycles, or other cargo. Additional cargo can be slung underneath (atmospheric operations only), although this cuts performance to 1/3 of normal (max speed 200km/h, cruise 150km/h). The interior is completely pressurized; the Life Support system is designed for 26 persons for 20 hours. For longer duration space missions, additional life support can be attached to the belly of the Meteor.

A civilian version is available as the Shooting Star class. These lack the military grade armor (HP 7, DCR 23), improved sensors and jammers, and the weapon mount points. It is a favorite of mining ships for it's compact size, mobility, and heavy lift capabilities. This shuttle is also a favorite of passenger transport services where the cargo compartment can be highly customized for either maximum comfort or seating.

Program	Level	Function Points
Atomic Drive	4	32
Alarm	1	1
Computer Lockout	3	4
Damage Control	1	1
Astrogation	1	3
Life Support	1	4
Communication	1	3
Computer Security	1	2
Installation Security*	1	3

* Military version only

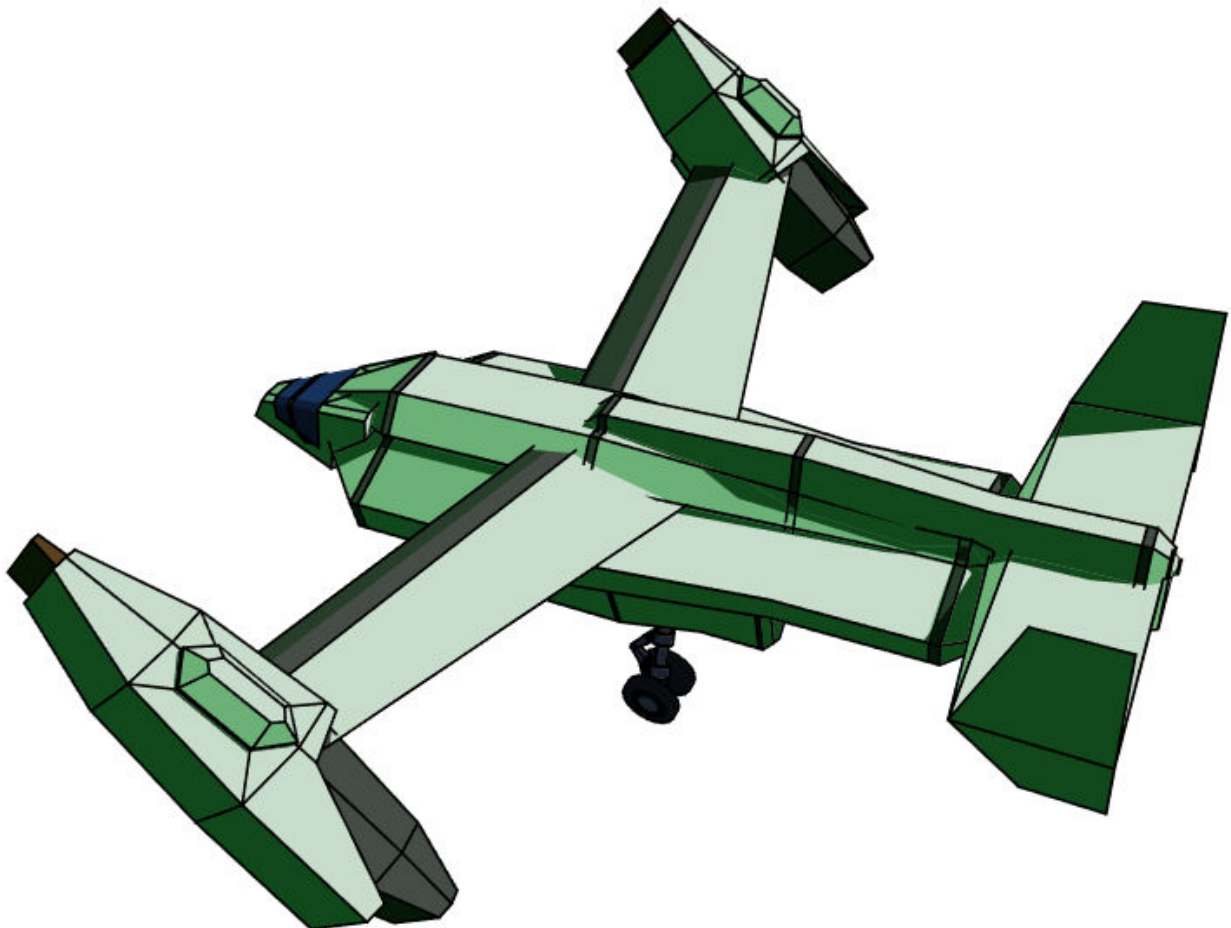
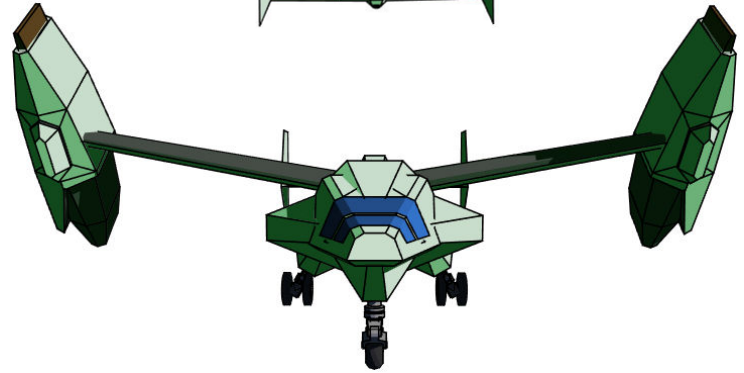
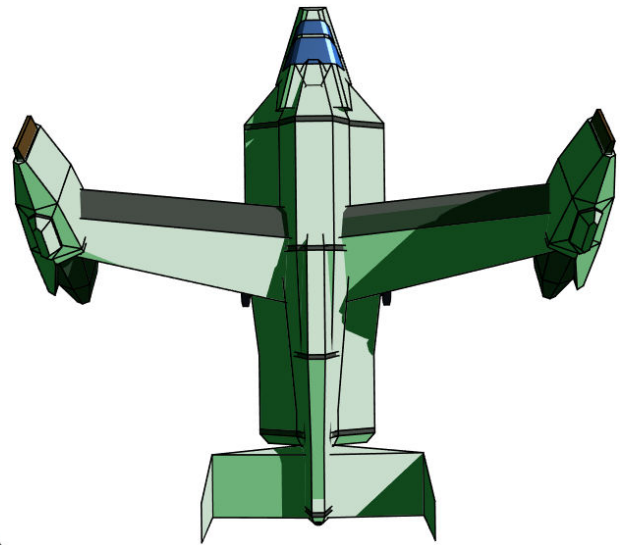

FRONTIER HISTORY

By Thomas Verreault
jedion357

RETURN TO VOLTURNUS

The Twilight of the Eorna or a New Dawn?

The purpose of this article is to review the state of affairs on Volturnus after the events in the classic campaign modules from the Star Frontiers setting. The climatic module suggested five ideas for further adventure on the planet but this work will avoid overlapping those ideas.

The first consideration before discussing any possible adventures or campaigns is to ask how the classic campaign ended. There were a number of possibilities allowed for in the module from the sathar actually winning the war and the player characters dying to the battle fleet from Truane's Star being triumphant. Also there was the classic TV ending of the eorna egg ship being found.

This article will only consider the issue from the perspective that the campaign had a successful ending and that the sathar were defeated. However, how many eorna are left needs to be addressed simply because they are the primary candidates for becoming the local authorities of the planet after the climatic battle.

In the module, "Volturnus, Planet of Mystery," we learn that 150 eorna survived the Day of Doom, or the day the sathar attempted to wipe out their civilization. These 150 continued to breed but the limited gene pool led to inbreeding and its resultant problems. At the time of the adventure there are 56 of the original eorna survivors of the Day of Doom, with most being in cryogenic sleep while only 10 are awake at a given time. Those 10 are assisted by their descendents who are not mentally deficient. We are not told how many of the descendents there are, only that there are quite a few who are criminally and mentally insane and have escaped the asylum set up for their care. It is possible to run into these dangerous eorna over a wide area of Volturnus. Almost any number could be suggested for the total population of remaining eorna but it does not seem that it would be very high, maybe 500 at most.

Another consideration is if the campaign ended with the egg ship being found with its 50,000 eggs. This item was included to change the status of the eorna from a dying race to one that will survive and thrive in the Frontier.

Whether the egg ship is found or not the eorna will represent a small population that could be easily shouldered aside by an aggressive mega corporation or the government from Truane's Star that has, in its mind, a legal claim to the system. If there is no egg ship in your campaign there is little possibility that the eorna can resist aggressive interlopers on their planet. With the egg ship and a little luck and diplomacy they may just hang on to their planet.

POSSIBLE OUTCOMES FOR A NEW GOVERNMENT ON VOLTURNUS

1. The government of Truane's Star steps in, asserting its claim to the system, and takes over citing the vulnerability of all the primitive native peoples. Under this circumstance, Streel Corporation will undoubtedly become a major player on Volturnus. Truane's Star will also become multi-system state, a rarity in the Frontier as only Terledrom is noted for having an extra system colony. Depending on the place of Cygnus Omicron IX and the reported police action there by the government of Pale, Truane's Star could turn into an expansionist empire or state (The United Systems of Truane's Star or the Palonite Republic?).
2. The mega corps would swarm into the power vacuum in Zebulon and set up shop. Under this circumstance there will be little authority other than that of individual security agencies or of that derived from the mussel of a gun. Expect mass exploitation of the natives and rape of the natural resources. Volturnus will have a Wild West feel and mercenaries will be major players and corporate war an almost certainty at some point.
3. The United Planetary Federation steps in and makes it a territory of the UPF with a governor. The planet may become like Puerto Rico is to the United States or be more like the Indian Territories overseen by Judge Parker (the Hanging Judge) of Wild West fame. Under this circumstance corporations will seek to develop markets with the natives and exploit resources but may be forced to set up shop in corporate enclaves in an effort to limit damage to the native peoples. Star Law will likely become a major player being tasked to keep the peace and protect the natives. The UPF might even set a Native Protective Agency to police the mega corps and handle problems arising with the natives.
4. A diminished and dying eorna race somehow manage to hang onto the government of their own planet. Under this circumstance they will not have

enough resources and will require a labor pool from outside their race. Possible candidates for this could be the mechanons (which may explain the mechanon uprising), the native peoples who's evolution they have accelerated (in light of their "Great Mission" this would be very controversial), hired labor from the Frontier, or deals with mega corps licensing them to exploit various resources in exchange for crucial infrastructure. Star Law, a mega corp, The Capellan Free Merchants or a mercenary company could become a major player here under this scenario. Since the eorna are facing extinction they are likely to accelerate evolution of their native races in an effort to groom them for taking over administration of the planet. No doubt they will also seek an alliance with the UPF for protection.

5. A thriving and growing eorna race some how manages to hang onto the government of their planet. Under this circumstance they will still need a labor pool beyond their race's resources but they may not find it necessary to pressure the mechanons or accelerate the development of their native peoples. There is still a high likelihood of mega corp involvement. The Capellan Free Merchants is very likely to offer aid in exchange for a free reign to carry on business with little regulation. The eorna will be forced into using a crèche system to raise their next generation. This will mean a highly structured setting for their hatched eggs with an emphasis on rules, routine and discipline. There will be the strong possibility of social upheaval in their society.

A significant possibility for adventure could arise from the impact of the above outcomes on the native races of Voltunus. The impact could be drugs and intoxicants or some other dangerous technology being peddled to them. For example if the edestakai received gun powder and muskets they would adapt them to the current fighting style of formed blocks of pikes. This would enable them to field armies of pikes and muskets similar to those in the English Civil War. Due to the importance of quick deaths as an embodiment of their god of justice they may decide to make war on the ul-mor, who hunt them as part of their "manhood" ceremony.

If the player characters are mercenaries, Star Law, or a native protective police they would be tasked with tracking down and stopping the exploitation of the native and with preventing one group of natives from harming another.

Then there are the mechanons who are suppose to have an uprising at some point which culminates in a mass exodus to an uninhabitable star system. There is great potential for conflict here that verges on outright war. In a game I once played in, the referee set up the mechanon uprising in the flavor of the classic movie, "55 Days at Peking" with Charlton Heston. The game played pretty much as the historical events surrounding the Boxer Uprising with the mechanons cast as the Imperial Chinese and the Boxers. The players were the special action team employed by the eorna and had to

coordinate with the various mega corp security personnel, a handful of Star Law agents, and a large number of ul-mor, kurabanga, and edestekai equipped in their traditional manner. As the western enclaves in Peking were besieged, the rebuilt city of Volkos was also besieged.

An oft overlooked detail comes from the system brief in "Crash on Voltunus." The module says, "As soon as the eorna launched their first colonization starships, they were attacked by a sathar space armada." Note that it says there were multiple starships launched by the eorna. No doubt at least one ran into the sathar and led to the discovery of Voltunus by the evil worms. However, what if not all of the ships were intercepted by the sathar? Could there be other societies of eorna seeded elsewhere in the galaxy. If evidence of this possibility turned up the eorna on Voltunus would want to make contact. It could change the race's chances of survival if these "lost" eorna agreed to return to their cradle of birth.

This adventure could begin innocently with a Capellan Free Merchant having an artifact that must have come from one of the eorna starships. He has since moved on and the eorna detail the player characters to run down that artifact which has now been sold. They must travel the Frontier to find the ifshnit trader and convince him to give them the name of the new owner of the artifact. Then they must obtain it by some means, legally is preferable and finally unravel the mystery of the missing ship. The PCs may be required to outfit a ship and dodge through sathar territory to destinations unknown seeking lost tribes of eorna. Rewards for success would be very high indeed.

The possibilities for adventure centered on Voltunus are far broader than the brief suggestions at the end of the third Voltunus module. Referees considering them should spend some time determining the new government of Voltunus and its impact on the setting.

Player characters could begin as entry level security forces detailed to resolve problems with the native peoples. After they've gained experience, they could be thrown into the siege of Volkos during the mechanon uprising. If they don't already have spaceship skills it might be that the authority they answer too will pay for them to attend a militia academy (maybe even on Clarion?) in exchange for them setting up a new militia organization. After their training and midshipmen cruise they take possession of a new assault scout and fly it to Voltunus for more adventures or the quest for the lost Eorna starships. The possibilities are broad indeed. The only question left is, "Are you ready to return to Voltunus?"



FRONTIER TIMELINE

By Thomas Verreault
jedion357

ORIGIN OF THE SPECIES & THE UPF

-OR- THE AGE OF COLONIZATION

Author's Note: This work represents my embellishment of the Star Frontiers game setting and timeline. It does not strictly follow the original material but I feel it maintains the spirit of it. While I did make some changes in the details of the timeline, in the end they represent what I like to call "zero sum change". What zero sum change means is that despite the changes that are made, the classic adventure setting is unchanged in its details. For example, Fromeltar is still a world populated by vrusk and dralasites and has a heavy population density. Clarion is still a human world with a monarchy that has seen twenty or more rulers.

The history and timeline below only advance as far as what appeared in the Alpha Dawn book or to just after the founding of the UPF. The map of this era is strictly the classic Alpha Dawn map but excluding the Zebulon system.

Where the original material had inconsistencies I put greater weight on the Alpha Dawn background and the published modules. Zebulon's Guide was of course consulted but due to the way in which it was rushed into print and the fact that it is the largest single source of inconsistencies, I only used it as a guide. Dragon and Paragon magazine articles were also considered and judged on their individual merits as to what weight they should be accorded in this work.

Special thanks, is due to Tom Stephens/TerlObar for assistance with astronomical details and feed back. Larry Moore/w00t was invaluable as a sounding board. Many others contributed through chat and forum post over the past many months though if I tried to list them all I would undoubtedly overlook someone.

OF VRUSK AND DRALASITES

In a star system called K'rik-Var, on a planet named Ren-Kit lived a sentient species whose name would translate as vrusk in a language that had yet to be invented. The vrusk had cast off the shackles of their hive society and formed a new social contract based on belonging to a trade house (later conglomerates emerged). Where the hive system had failed to unify the planet, the new model ushered in a planet wide government; a council of the most prominent trade houses.

As the vrusk began to exploit their world and star system, they began to cast their eyes toward distant stars. Within decades they had developed effective theories of void travel and journeyed to a neighboring system. The new star system was named Kizk-Kar and a colony was started on a planet named Zik-Kit.

Just when the debate over the cost of the new colony vs. the profit from its mining operations was raging, astronomers discovered an anomaly. There was an artificial object of immense size drifting in the edge of the Xagyg Dust Nebula three light years from K'rik-Var. Converting a transport for scientific investigation, they sent a team that discovered a globe like ship, empty and drifting. It took a year but they managed to decipher and adjust its automated controls and bring it to K'rik-Var.

As they began to delve into the ships mysteries they discovered that the storage containers of what they had assumed was some form of bio-plasm were actually stasis chambers holding sentient life forms, the dralasites. The revived passengers had no memory of how they had come to be on the globe ship or where they were from. The vrusk, delighted with the discovery welcomed them into their society.

The dralasites for the most part struggled with the larger questions of whom they were and where they came from and their integration into vrusk society was not without difficulty. Problems arose with the government as the vrusk companies in control saw no reason to change the status quo and continued to exercise total executive control of their society. Eventually a second planet in the system, Groth, was turned over to the dralasites who found adjustment to life on Ren-Kit too difficult. The vrusk population of the second planet was induced to move with lucrative incentives for those who relocated to the new colony in Kizk-Kar.

The council of vrusk companies stoutly maintained its control of the K'rick-Var and Kizk-Kar systems with little concern for their alien guest. Unfortunately some dralasites were not content with allowing the vrusk to control nearly every aspect of their lives and they campaigned for the return of their cultural heritage, the globe ship. When it did not seem that the ruling council would acquiesce to their demands, a reactionary group stormed the ship and hijacked it. Armed with the astrographic data for a new system recently explored by the vrusk they took the globe ship there.

Upon arrival they named the system Dramune and colonized the planet Reach. Being hijackers they were not well outfitted for colonization and were immediately forced to cannibalize their ship, dismantling it and bringing it to the surface.

The vrusk council was incensed and sent ships to assert their claim to the system. However, having abolished war along with the hive system they were ill prepared for the intransigence of the hijackers. In short order the vrusk were forcibly expelled from the planet Reach. This event rocked the council as it had never considered that they would not be obeyed. The pacifist vrusk were forced to consider using force.

The issue dragged on for a number of years and came to a head when dralasites on Ren-Kit and Groth assembled a donation of relief material and contracted a ship to send aid to the planet Reach. The vrusk realized that armed conflict could lead to civil war. In a remarkable turn, the vrusk council instituted the election of dralasites to the governing council of Ren-Kit and recalled its monitoring and mining outpost on a planet that would eventually be called Outer Reach in the Dramune system. With the relinquishing of their claim to the Dramune system, relations stabilized and for a few years the dralasites of the K'rik-Var system sent yearly relief to Dramune while the vrusk turned a blind eye.

The dralasites of the Dramune system represent the more reactionary elements of their race as their actions demonstrated but in time members of the race had migrated back and forth from the two systems and the make-up of the race became homogenized despite spanning three planets. An interesting custom persists in Dramune, dating to the founding of the colony; the dralasites paint their bodies with washable dye to denote their mood for the day. This custom began with the reactionaries and only persists out of tradition but modern dralasites of Dramune are no more reactionary or any less philosophical than the rest of their race dwelling elsewhere.

Interestingly, the name of the vrusk home system has not entered into popular usage in the modern Frontier. When the dralasites first arrived they developed Dral speech equivalents to the Vrusk names. When Pan-Gal was created as a universal trade language, the lead linguist, being a dralasite, incorporated the names Fromeltar, Terledrom, and Groth instead of the original names. Since vrusk are forced to rely on a polyvox for communication they simply use the original names in

their language and the polyvox translates it automatically to the Pan-Gal equivalents.

OF HUMANS

A twelve ship colony fleet leaving the Sol system headed for Epsilon Eridani was destined to make an important discovery; void travel. The colony leaders had no idea that their ships would enter void space at 1% of light speed and blissfully went into cryo-sleep. They expected the lead ship's robotic brain to deliver them to the neighborhood of Epsilon Eridani and revive them. The robotic brain faithfully maintained the course and with all twelve ships racked into a frame behind an ablative ice shield (designed to intercept dust and matter that would damage the ships at percentages of light speed) they expected to wake up for periodic checks and eventually arrive in a brave new star system.

What they woke up to was the warped reality of void space. With all the command crews brought to full consciousness, debate ensued as to what to do. One junior captain, Leonine, deduced the nature of what had happened and proposed that deceleration to less than 1% of light speed would drop them back into normal space. Eventually, for want of a better idea, Leonine's plan was acted on. The twelve ships unracked from the shield's frame and reversed thrust. It was uncertain what their true speed was in void space as forward thrust had been continually applied even after entering void space, thus significant amounts of fuel reserves were used to just drop out of the void.

It was impossible for the ships to communicate once unracked making it difficult to ensure that all the ships maintained the exact thrust profile. The result was seven ships dropping out of the void in a star system, four near a nebula and one was never heard from again.

The colonists on board the seven ships were indeed fortunate, as the system possessed an inhabitable planet. Since the expedition had planned for redundancy, even with only seven ships they were well prepared to colonize this planet. In addition their passenger compliment included the colonial governor, who was an able administrator. The new system and planet were named Theseus and Minotaur respectively.

Sensing despair seeping into his colony over the loss of the other ships, Governor Meier modified the colonial plan written back on Earth. The plan called for the dismantling of the colony feet for use on the ground in the effort to establish the new colony. Instead he reserved the ship with the robotic brain in orbit and tasked the robot with monitoring the weather satellites, scanning the heavens to ascertain if they were still in the Milky Way, and to maintain a radio watch for the missing ships. Just enough fuel for one shuttle was conserved to provide a limited number of flights to the orbiting ship for maintenance purposes. This illusion of maintaining space capabilities fostered hope in colony.

The four ships that dropped out of the void near the nebula (later named the White Light Nebula) included the junior captain, Leonine. He formulated a theory of void space and proposed the small fleet make for a blazing star near by. His plan took some convincing of the other captains but in the end their limited fuel and his insistence that he could get them to the nearby system won them over. Since his theories were essentially unproved he was forced to guesstimate the amount of time for their void jump.

His guess paid off and three out of four ships arrived in the system that they named, White Light. Fortune smiled again, providing a habitable planet that would be named Clarion. The fourth ship miss jumped and its crew and passengers would begin a small farming colony on a planet that would be eventually discovered after the founding of the United Planetary Federation; Kraatar in the Triskkar system.

However, the Clarion colony was not out of danger, as the colonial plan projected a 75% chance of viability with only three ships. Distressingly, the leaders of the three surviving ships ran things by committee and debate. Lack of a centralized vision almost doomed the colony to failure.

Captain Leonine, as the hero who had saved them from death in the depths of space not once but twice, stepped in by popular acclaim and took control as a dictator. His steadfast iron-will turned the situation and within three years it became apparent that the colony would prosper and survive.

Being a student of history, the idea of a dictatorship troubled Leonine and he proposed a change of government. Still the acclaimed hero, he had his detractors who for all appearances simply wanted power for its personal exercise. Knowing that the colony would continue to require a strong executive leader for years to come he proposed a constitutional monarchy and won over his opposition by offering them hereditary titles and a position in the House of Lords. The constitution was accepted and it gave him the same powers he exercised as dictator but only for as long as the House of Lords and House of Commons continued to authorize him these emergency powers. Within two years his opposition led the charge to prune back his power and make Clarion the true constitutional monarchy it is to this day.

Seven years after instituting the monarchy Leonine hatched a plan to subvert the next generation of his opposition. He established two new institutions; the Royal Mounted Constabulary and the Royal Merchant Marine and promoted the idea of noble obligation to the colony among the nobility. His opposition in the nobility saw public service as a path to power for them and their children. However, the culture and institutions of the RMC and RMM carried a strong current of loyalty to the Crown and their ranks were equally flooded with commoners who were his strongest supporters.

The Royal Mounted Constabulary is the planet wide police answering directly to the Crown. Early in their

history they were mounted on genetically engineered equine stock brought from earth. However, they adapted new technology to their methods as it became available. The "Mounties" have proved an innovative police force and while they embrace modern 'mounts' like hovercraft which are better suited to the many swampy areas of Clarion, they still maintain a large stable of live mounts for mountain patrol and ceremonial duties.

The Royal Merchant Marines inherited all space based responsibilities. The RMM were tasked with rescue and operation of all government craft as Leonine had preserved the colony's space capabilities.

A key element of Governor Meier's hope initiative was sending out radio messages to try to locate and lead the lost colony ships home. Despite the realization that those ships would never have had enough fuel to survive for long the messages were beamed out for several years. Ten years after the founding of a colony in White Light the survivors, who were now led by King Leonine I, heard the distant radio call of their long lost fellows. The first major mission for the Royal Merchant Marine was charting a jump route to Theseus and establishing contact with the rest of the colonial expedition.

In Theseus there was elation at the arrival of the Royal Merchant Marine followed by consternation. Many of the power brokers of the Minotaur colony remembered Captain Leonine as an upstart junior that had been humored more than listened too. The thought of his crowning himself king was laughable. Governor Meier had established a democracy. The Minotaur's governing representative's heaped scorn on the idea of modern humans being ruled by a monarch. There was also the assumption that the lost colonist would naturally want to travel to Minotaur. Yet the citizens of Clarion were proud of their accomplishments, their new traditions and their monarch. In the end the disparaging comments about Clarion's soggy environment and frequent rain was taken as an insult. The derogatory label of Gollywog evolved and the citizens of Clarion rejected the offer of assimilation into Minotaur's society.

It took Governor Meier traveling to White Light to smooth relations between the two colonies. There he witnessed the prosperity, and enviable industry of Clarion's citizens and his mission to Clarion established key agreements for the purpose of cooperation.

Being a classically trained scholar of Greek philosophy he gave his most famous speech, proclaiming, "The dawn of a new beginning for humanity in a new frontier." Interestingly, the philosophical writings of Governor Meier were destined to become extremely popular among dralasites. Generations of human children as well as dralasite buds would memorize the speech as part of their education. At the founding of the United Planetary Federation a dralasite delegate paraphrased Meier's famous speech and declared the, "Alpha Dawn of a new Frontier."

Both colonies had taken the planets dealt to them by fate but they were not planets of their choosing. It was fortuitous that they had found inhabitable worlds however neither planet was suited to the raising of Earth crops. They certainly could become so with major terra-forming efforts but the strain of the sometimes desperate situation in the early days left both colonies ill prepared for full scale terra-forming. In Clarion's case food production required large domes to protect the crops from the environment. On Minotaur the native species were invasive and harmful to plants from Earth requiring intensive back breaking toil to produce any food at all. In response the Frontier Agricultural Resource Mission (FARM) was formed.

This joint mission was mandated to locate suitable planets for planting self sustaining farming outposts. Suitable volunteers (those with requisite knowledge and skills) from either colony could apply and would receive a "stake" in equipment, seed, and livestock that they paid back with food. The new farming outpost would also be self determining and not ruled by either colony. Due to the differences of the sponsors political systems the self governing feature of the new colonies was the only viable way for the two parent colonies to cooperate and establish new colonies jointly.

Royal Merchant Marines provided the spacers while Minotaur provided the scientists for the survey expeditions. In short order, routes to Timeon and Madderly's Star were charted. Both had worlds that were suitable environments for Earth crops.

The next stage was to establish farming outposts. Lossend in Timeon was the first. Madderly's Star was planned as stage two for the mission but kept getting delayed. At first the delays were logistical, as the RMM were stretched thin keeping Lossend, Minotaur, and Clarion in communication with the three remaining void capable ships available to humans in the Frontier. Then Madderly's Star was delayed as resources were poured into finding the source of mysterious radio signals that were being detected.

OF FIRST CONTACTS

The human colonies would maintain contact and trade enforcing strict population growth policies to grow their planetary populations as fast as possible to empower the work forces for the growing societies. For another eighteen years no one considered much beyond the needs of the three colonies (Clarion, Minotaur, and Lossend).

During that time radio traffic, emitting from all six inhabited systems of the Frontier; Fromeltar, Kizk-Kar, Dramune, Theseus, Timeon and White Light; raced out to waiting communications gear. In the eighteenth year since the establishment of humans on Clarion they detected signals from the vrusk. A year latter the vrusk and dralasites began intercepting signals from the humans.

Suddenly all three races were pouring money into exploration. Minotaur's last surviving colony ship was still orbiting its world as a glorified satellite. A

cooperative venture was organized to overhaul Minotaur's ship and lay down hulls for more ships. The first mission was to map the star routes in the direction of the alien transmissions. In the Cassidine system they met a vrusk ship coming from Dramune.

First contact was cordial. Cassidine saw the establishment of the first multi-species colony to facilitate scientific and cultural exchange. The colony was named Triad to reflect the fact that three races had come together in peace.

At this point the Frontier had a total of seven inhabited systems. The resource mining on Clarion produced tons of plastics and fuels while the growing industrial base on Minotaur churned out finished goods. The Farming outpost on Lossend was a major success and its parent colonies were no longer in danger of starving. At this time King Leonine II determined that Clarion would expand its space presence by building a station and shipyard in orbit. The decision was not initially popular but he reasoned that Clarion would need to stay in the fore front of space industries to prosper in the growing Frontier.

COMING OF THE YAZIRIANS

On a planet orbiting a lonely K type star in an area of space that would come to be called The Vast Expanse evolved a sentient species that called themselves yazirians. They were a clan based society that indulged in frequent wars and yet they were destined for great things among the stars.

Their journey to the stars began at the conclusion of the final Great Clan War when the victorious warhon unified 90% of the planet and established an imperial dynasty. For nearly eight centuries the yazirians progressed by fits and start through industrial, scientific, and technological revolutions. Eventually they mastered space flight and began to exploit their star system.

In the 789th Year of the Warhon, Clan Anglann discovered evidence that their star system would experience the visitation of a wandering brown dwarf. Long before the dim star was visible even to sensitive yazirian eyes, gravitational anomalies were seen in the orbits of objects in the outer system. The reigning Warhon wanted it kept quiet but the news leaked anyway. Facing the total destruction of their planet due to the impending close pass of a brown dwarf, they dispatched vessels to brave the Vast Expanse. Six years latter one returned with news, an inhabitable system had been found and named Araks.

The Warhon, his council and Clan Anglann formulated a twenty five year evacuation plan for 98% of the population. Clan Anglann spearheaded the operation by terra-forming a new home world for five years in preparation for the first wave of colonist. The year after the arrival of the first wave to the planet Hentz, the leaders of Clan Anglann detected radio signals from the other races living in the Frontier. They dispatched a ship and charted the jump route to Athor then Prengular.

During the disruptions on Yazir due to the discovery of its impending destruction there were signs of a return to clan based warfare. In response to that a philosophy developed that enshrined the idea of all yazirians as one family. The idea was that they all had to come together as a family to survive the disaster irrespective of clan affiliation. The name of the philosophy evolved into, 'the Family of One.' It eventually took on religious overtones and gained power as the evacuation plan went forward.

Once Clan Anglann realized that they lived in an area of space populated by three other space faring races, they rewrote their mandate. Consolidating their control of Hentz under the religious philosophy of the Family of One they made themselves the high priest of this new religion. Next they began terra-forming Yast in the Athor system and diverted the second wave there when it arrived.

Not long after second wave's arrival a ship from Clan Anglann ventured into the Prenalang system. The ship that was sent was armed and expected to encounter intelligent aliens. A survey crew of Royal Merchant Marines was there with a team of scientist from Minotaur. The yazirians quickly overwhelmed and captured the ship orbiting Gran Quivera. When they landed to capture the group on the ground they came up against a canny opponent, Captain Morgaine of the RMM. He and a few crew members managed to trap, capture or neutralize the yazirian landing party. Then they commandeered the yazirian shuttle to counter board the ships in orbit.

The yazirians were stunned, they had been better armed and now they were the prisoners. To be fair the members of Clan Anglann had never been noted for being part of the military establishment and Captain Morgaine had prior military experience reaching back to Earth. Morgaine's shrewdness showed again in his diplomacy with the yazirians. Despite neither race being able to fully communicate with the other he manage to deduce the clan nature of their society and guessed that honor was everything to a yazirian. Despite the objections of his crew he returned the yazirians to their ship with their weapons. He sent the yazirian leader aboard his ship and he went aboard the yazirian ship. An invitation to return to Prenalang in one local month for a formal meeting of leaders was established and the ships went their separate ways.

The yazirian captain's experiences were bland compared to Morgaine's. He formally met the heads of state for humanity in the Frontier as well as delegates from Dramune and Fromeltar. Captain Morgaine was brought before a religious court and successfully endured several "trials of honor." In the end his prowess, shrewdness, and honor won him a wide following of admirers.

It was Chief Harsevoort of Clan Knar-Kenda that, though allied with Clan Anglann and knowing that the chiefs of Clan Anglann would rather that Morgaine was humiliated or killed, put a stop to the Trials of Honor.

Normally a yazirian only had to pass one such trial but Morgaine had succeeded at three and made it look easy. He even mastered the yazirian honor weapon, the zamira, relying on muscle memory from his youth when he tossed a frisbee with his Labrador Retriever. At the end of the third trial Harsevoort stepped forward and placed his personal clan symbol around Morgaine's neck and declared clan alliance with "Clan Morgaine." The irony of that act was lost on the yazirians as they had no way to know that Morgaine was a bachelor with no other family in the Frontier.

Clan Anglann, bent on creating an interstellar empire was stumped. They could not continue trying to humiliate or kill Captain Morgaine through trials of honor lest Clan Knar-Kenda, their closest allies, declare clan war on them. They decided that they must study these humans to better understand their weaknesses. Thus, they sent him and a delegation to the meeting on Prenalang.

At this meeting vrusk and dralasites were present. By this time linguists had adequately tackled the yazirian language and relations stabilized quickly. Another joint colony much like the Triad colony in Cassidine was proposed and quickly accepted. Clan Anglann flooded the yazirian contingent in Prenalang with those who were pro Family of One.

After the second wave arrived, the route to Gruna Garu was mapped and they repeated the process of terra-forming in preparation for the third wave. The sequence was repeated in the following five years for Scree Fron as well.

The year after the fourth wave arrived on Hakosaur in Scree Fron with the last remnants of the yazirian population that were willing to relocate from their doomed home-world, the Warhon and his personal body guards departed for the Frontier. Quite mysteriously one ship never arrived, the one carrying the imperial court. It was the only ship to not survive the trip in twenty five years. Clan Anglann, having become synonymous with The Family of One became the center of conspiracy rumors even as it attempted to establish a multi-system theocracy.

The uproar over the loss of the beloved imperial leader prevented the Family of One's aspiration of a galactic empire. There was no proof of culpability so the citizens of Yast, Hargut, and Hakosaur settled for organizing their own governments. They could not fully rebuff the Family of One as they were still dependent on them for terra-forming. (Note: the terra-forming of the yazirian colonies was to take longer than five years each. Clan Anglann was forced to improvise plans at the discovery of the three other races. In the end it used its control of the terra-forming processes and the genetic library imported from the home world as a string to control the recalcitrant colonies. Yast, Hargut, and Hakosaur are not happy with the situation but Clan Anglann has them over a barrel and they can't break too far with Hentz.)

Elements of the imperial warhon's advanced guard didn't require hard proof of culpability. They swore blood oaths against the Family of One but preparations had been made to deal with them. In short order their voices of dissent were silenced or disappeared from yazirian society. Since that time it has been rumored that the surviving members of the Warhon's bodyguard have been secretly plotting their revenge.

A consequence of the way that the colonization waves were diverted to new planets has brought about an artificial distribution of yazirian clans that never existed before. If the original evacuation plan had been followed as written then all of the clans would have been represented on Hentz. Some sociologist warned against the fracturing of the yazirian civilization this way and even a return to clan wars but a greater threat in the form of the sathar prevented that during the early days of the Age of Colonization.

Upon Captain Morgaine's return to Clarion, the King tried to elevate him to the status of Duke with a place in the House of Lords. He flatly refused and instead said he would accept a commission in the space navy that the Crown was going to need to organize. His experiences among the yazirians convinced him that humanity would sooner or latter need to defend itself in this brave new frontier, whether it was from yazirians or some other hostile race yet to be encountered. His opinion carried weight and the Royal Marines were organized with a hand picked cadre of officers and able bodied spacers from the merchant marine service.

CAUSES AND CONSEQUENCES OF THE FREE WORLD REBELLION

Like many tragic events the Free World Rebellion had its origins in simple twists of fate. The Frontier Agricultural Resource Mission had met with huge success on Lossend in the Timeon system. The volunteers for the next mission slated for Madderly's Star were repeatedly disappointed due to one unexpected delay after another.

Finally when the mission was about to go through, radio signals originating in vrusk space reached the White Light system. Naturally it was delayed again while the merchant marine service was tasked with discovering the transmission's source.

After first contact and the founding of Triad in Cassidine a new date was set for the FARM mission to Madderly's Star. However, fate took a hand again. A rising star among vrusk trade houses in the aerospace industry known as Nar lost its bid for the right to support the vrusk personnel in Cassidine. Undaunted, its director, Hatzk, conceived a plan to evolve the trade house into a conglomerate by founding a colony of his own in an unclaimed system.

Hatzk liquidated Nar's assets in Fromeltar and moved the trade house's operation to Madderly's Star and named the inhabitable planet Zdikit. His move upstaged the oft delayed FARM mission by half a year. By the time the human farmers arrived, House Nar had

built a space port, industrial farms, an industrial food processing plant and other key infrastructure.

The human farmers had planned their mission to be a self sustainable approach to food production designed to have a soft impact on the environment. It could not have been any more diametrically opposed in philosophy to the vrusk approach to farming on an industrial scale. Coupled with the resentment of the vrusk "invading their world" tension characterized the human-vrusk relations on Zdikit from the start. House of Nar's commitment to efficient exploitation of the planetary environment and to growing into a conglomerate quickly marginalized the human farmers.

Because of the original mandate that neither Clarion nor Minotaur would directly control the new farming colonies those governments did not directly intervene on Zdikit. With feelings of resentment and abandonment simmering, the human farmers organized Freedom Committees and soon after they began improvising weapons.

The spark that ignited the rebellion came when the House of Nar cleared land for yet another industrial farm within kilometers of the farm of a key Freedom Committee leader. The Freedom Committees stormed and vandalized the industrial farms. Hatzk tried to demand reparations and then the Committees of Freedom attacked the space port and rounded up all the vrusk they could. The majority of the human population supported eviction of the vrusk but a strong element of reactionaries began killing vrusk. The killings were quiet at first but not completely a secret. Hatzk witness the first massacre from orbit then dispatched ships to both Clarion and Minotaur to demand help.

Ironically, the Royal Marines, newly organized to oppose hostile aliens saw their first action against fellow humans. Thus their first mission was a police action. Sadly in the time it took the Royal Marines to reach Zdikit the killings had spread.

One extended family, the Jamisons, took a stand against the killings and prevented the total genocide of every vrusk on Zdikit. Even after the arrest of those directly responsible for the massacres and the restoration of order a large number of the Jamison family were murdered. Most of the survivors were forced to relocate. The young orphan of Jaque Jamisons named Luis was eventually taken in by a cousin who would relocate to a new farming colony on a planet called New Pale.

The House of Nar was rocked to its core after the Free World Rebellion. Most of its employees lost faith in the director and left the company. The vast majority of them were relocated to a new system called K'Tsa-Kar with aid given directly from the Crown of Clarion. Hatzk took the faithful few that remained at his side and the ships he still commanded and limped back toward Fromeltar. The failure of his grand plan was acid in his mandibles and he never reached Fromeltar.

He halted at the old vrusk outpost in the Dramune system on a planet now called Outer Reach. From this forgotten base he would embark on a new career that would make his name infamous throughout the Frontier; that of piracy. Changing his name to Hatzk Nar he preyed on all shipping in the Frontier, including vrusk flagged ships.

He met his end when the threat of his pirate band was so great that the First Common Muster was called of all Frontier militias to hunt him down. Morgaine, now the Lord Commander of the Royal Marines lead the combined fleet as admiral and headed for Dramune. Hatzk slipped past him and raided Cassidine before moving on to Prengular. Morgaine managed to catch up with him in Timeon. After a decisive battle with only a couple of Hatzk's ships escaping the vrusk pirate was ejected from an air lock to drift toward the system's primary and he boiled to death in his space suit.

Ultimately, the Free World Rebellion pushed other colonies, besides Clarion, to establish militias to combat Hatzk Nar's piracy. Had this not happened, there would never have been enough armed hulls available to assemble a fleet with which to withstand the sathar onslaught in the near future. Were it not for this tragic event the United Planetary Federation would never have existed.

Further consequences of the Free World Rebellion were the intertwined lives of Luis V. Jamison and the Star Devil. Without the rebellion Luis would probably never have emigrated to Truane's Star as a boy. As he reached adulthood he joined that system's militia and would eventually lead an expedition to Volturnus where he'd become embroiled with the Star Devil's band. While the Star Devil's true identity has always been a mystery, it is known that he was a member of Hatzk Nar's pirate band. It cannot be said for certain if he was with Hatzk on Zdikit but he definitely was a lieutenant at the base on Outer Reach in Dramune.

THE FOUNDING OF THE FEDERATION

After the First Common Muster, the Prengular system took on a new importance as most of the militias (not those in yazirian space) posted military liaisons on Gran Quivera to increase communication and cooperation. That fact coupled with the emergence of Pan Galactic Corporation effectively made Prengular the hub of the Frontier.

The sudden appearance of the sathar at Truane's Star and the images of their depredations beamed out via sub space radio shocked the Frontier. The quick and almost casual destruction of the Truane's Star militia worried the assembled military liaisons. Debate ensued over whether the worms could be stopped even as the call for the Second Common Muster went out and Admiral Morgaine was recalled from Clarion.

Of particular concern was whether or not the yazirians would join the muster. Admiral Morgaine ended that debate with a simple statement, "My brother Harsevoort will come."

Wearing Harsevoort's clan symbol, Morgaine sent a sub space message to Hentz, "Tell Harsevoort, Clan Morgaine is in need."

Without waiting for a response he immediately turned to organizing his fleet and planning his strategy. As the day approached that Morgaine had set for the fleet to move the combined militias of yazirian space appeared in Prengular. Admiral Harsevoort had come and brought every armed ship available, doubling Morgaine's fleet in size.

While Morgaine had been hailed as a hero for stopping Hatzk Nar he considered that action a failure since Hatzk had slipped past him to raid Cassidine and Prengular. Acutely aware that he knew little about the sathar he was determined to not underestimate them like he felt he did Hatzk. With the outpost at Dixon's Star to warn if the sathar moved toward Prengular he shrewdly guessed that they could have jump route from Truane's Star to Cassidine and place his force there.

With his fleet hidden in Cassidine's dense asteroid field he ambushed and defeated a sathar fleet. Even as wrecked ships still glowed from the battle, word arrived of a sathar force moving on Dixon's Star. Admiral Morgaine withdrew his fleet to Prengular and prepared for its defense. The defenders would not wait long as a sathar fleet equal to the one they had already ambushed arrived and headed straight for Gran Quivera. Admiral Morgaine intercepted it near the system's second inhabitable planet. The sathar were again stopped but the cost was great. No ship that survived was unscathed and admirals



An Outer Reach militia ship attempts to outrun death from an unknown aggressor.

Morgaine and Harsevoort both lost their lives (the first three battleships built for Space Fleet would be named for heroes of this battle). The shattered sathar force fled into the void.

The planet that witnessed the titanic battle was renamed in Morgaine's honor. Clan Knar-Kenda erected statues of the two fallen admirals in their clan gardens that memorialized their lost homeland on their native planet and renamed it the Garden of Remembrance, a practice that is followed by many clans to this day. Admiral Morgaine further has the distinction of being the only non-yazirian memorialized as a statue on Hentz.

Though the sathar fleet had been smashed there were still thousands of sathar infantry on Pale and Laco as well as sathar attack monsters (quickdeaths and cybo-dragons). Pan Galactic Corporation turned its industrial might to rearm the depleted militias and equip a landing force. The ground battle for Pale turned out to be some of the most vicious fighting of the war. Curiously the farming colony on New Pale was left untouched.

In the aftermath of the war delegates from all over the Frontier converged on Prenalgar. A Congress was empanelled to consider matters of mutual protection. The end result was the treaty that created the United

Planetary Federation, the Council of Worlds and Space Fleet. All seventeen inhabited systems quickly ratified the treaty.

To this day the Royal Marines of Clarion, being organized by Captain Morgaine are accord unofficial clan status as Morgaine's heirs by Clan Knar-Kenda. The clan's leaders continue to assert clan alliance with "Clan Morgaine" despite pointed comments from the head of the Family of One. Morgaine and Harsevoort may be dead but they are not forgotten. Members of Harsevoort's clan regularly volunteer for service in the Royal Marines and commissions from the Royal Marines are honored in the Araks militia.

Pictured below; unable to defend or outrun the sathar warship, a freighter leaving the Truane's Star system falls victim during the first moments of the war.

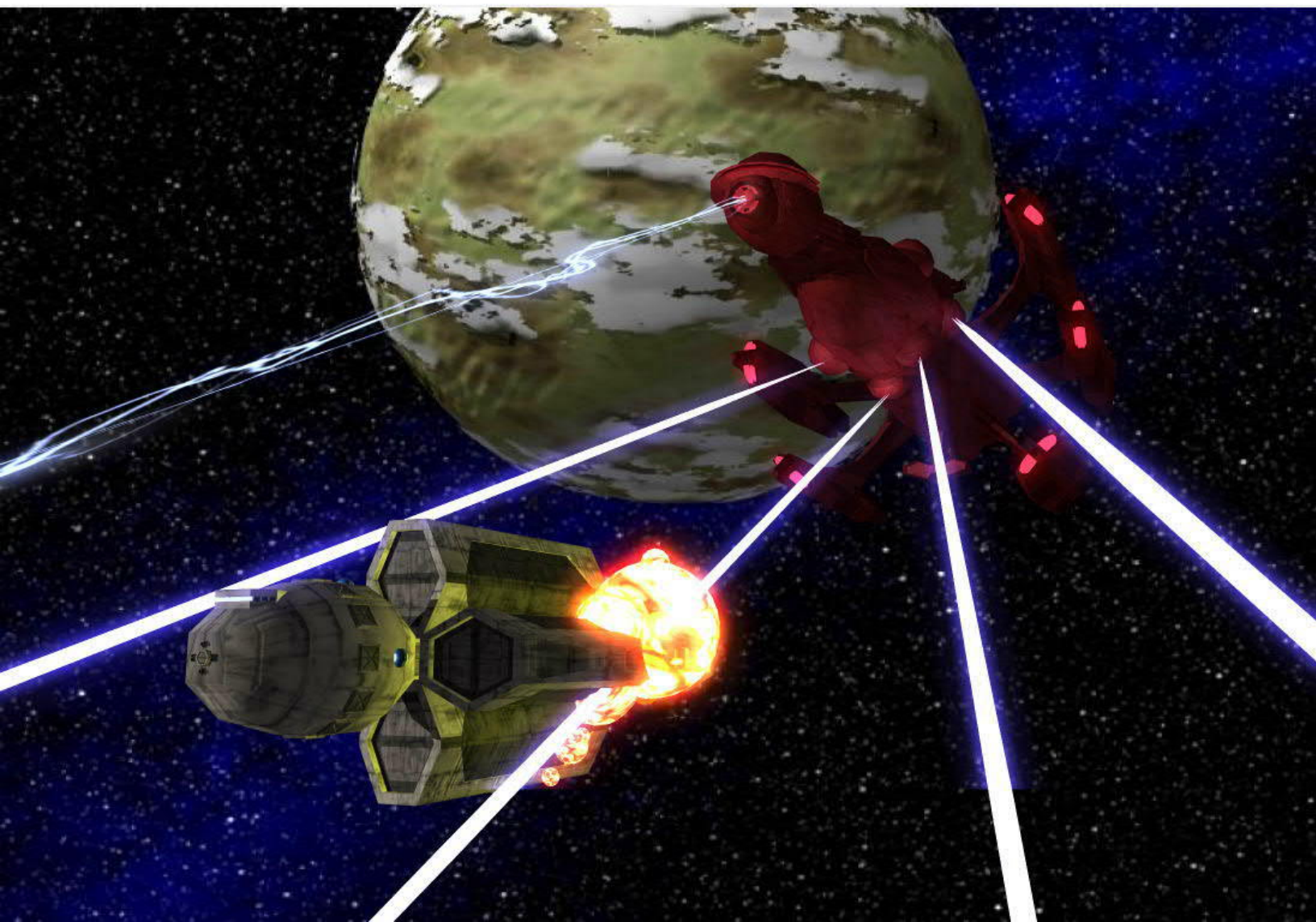

Event	UPF Time Line	Theseus	Clarion	Yazirian Imperial	Yazirian Religious	Vrusk
Age of the Warhon & end of the Clan Wars	733 PF			0		
Official end of the Hive system on Ren-Kit by the vrusk	613 PF			150		0
Vrusk Space Age begins	188 PF			681.25		187
Vrusk discover Kisk-Kar and colonize Zik-kit	163 PF			712.5		198
Vrusk discover anomaly drifting 3 LY from home system	159 PF			717.5		199.76
Vrusk bring anomaly (globe ship) to K'rick-Var	156 PF			721.25		201.08
Vrusk revive dralasites from stasis sleep on globe ship	155 PF			722.5		201.52
Dralasites given 2nd planet in Ren-Kit system (Groth)	147 PF			732.5		205.04
Reactionary dralasites travel to Dramune & colonize Reach	145 PF			735		205.92
Vrusk assert claim to Dramune but envoy repulsed	144 PF			736.25		206.36
Humans arrive at Theseus & White Light	143 PF	0		737.5		206.8
Vrusk reform government in K'rick-Var to include dralasites	141 PF	0.4	0	740		207.68
Constitutional monarchy est. on Clarion	140 PF	0.6	0.05	741.25		208.12
Relations between Dramune and Ren-Kit normalize	139 PF	1	0.1	742.5		208.56
King Leonine establishes the Royal Merchant Marine	133 PF	2	0.4	750		211.2
Royal Marines detect radio signals from Theseus	130 PF	2.6	0.55	753.75		212.52
Vrusk map route to Cassidine	123 PF	4	0.9	762.5		215.6
Humanity detects radio signals from vrusk and dralasites	122 PF	4.2	0.95	763.75		216.04
Vrusk and dralasites detect radio signals from humanity	121 PF	4.4	1	765		216.48
Humans, vrusk, & dralasites meet at Madderly's Star	119 PF	4.8	1.1	767.5		217.36
1st truly mixed race colony started at Cassidine	115 PF	5.6	1.3	772.5		219.12
Vrusk est. an enclave at Madderly's Star	111PF	6.4	1.5	777.5		220.88
Humans join vrusk colony at Madderly's Star	110 PF	6.6	1.56	778.75		221.32
Yazirians realize the magnitude of the coming disaster	102 PF	8.2	1.95	788.75		224.84
Yazirian exploration ship returns with news of Araks	96 PF	9.4	2.25	796.25		227.48
Clan Anglann begins terra-forming operation on Hentz	93 PF	10	2.4	800		228.8
Route to Prengular system mapped from Madderly's Star	90 PF	10.6	2.56	803.75		230.12
Arrival of 1st wave of yazirian evacuees in Araks	88 PF	11	2.65	806.25		231
Clan Anglann detects radio signals from other races	86 PF	11.4	2.75		0	231.88
Routes from Araks to Athor & Prengular charted	85 PF	11.6	2.8		0.46	232.32
Arrival of 2nd wave of yazirian evacuees in Athor	83 PF	12	2.9		1.38	233.2
Prengular colony est. by members of all four races	82 PF	12.2	2.95		1.84	233.64
Routes to Dixon's Star and Truanes Star mapped	80 PF	12.6	3.05		2.76	234.52
Routes to K'aken-Kar & K'tsa-Kar mapped	79 PF	12.8	3.1		3.22	234.96
Arrival of 3rd wave of yazian evacuees in Gruna Garu	78 PF	13	3.15		3.68	235.4
Truane's Star colony est. by humans	77 PF	13.2	3.2		4.14	235.84
Pan Galactic Corporation (PGC) founded	75 PF	13.6	3.3		5.06	236.72
Arrival of 4th wave of yazirian evacuees in Hakosar	73 PF	14	3.5		5.98	237.6
Last recorded ships leaving Yazirian home system	72 PF	14.2	3.55		6.44	238.04
K'aken-Kar est. by vrusk	69 PF	14.8	3.6		7.82	239.36
Free World Rebellion at Madderly's Star	63 PF	16	3.9		10.58	242
Royal Marines intervene at Madderly's Star	62 PF	16.2	3.95		11.04	242.44
Vrusk of Madderly's Star evacuated to White Light	61 PF	16.4	4		11.5	242.88
Refugees from Madderly's Star resettled in K'tsa-Kar	60 PF	16.6	4.05		11.96	243.32
Ancient ruins discovered at Dixon's Star (Tetrarchs)	56 PF	17.4	4.25		13.8	245.08
Outpost established at Dixon's Star	55 PF	17.6	4.3		14.26	245.52
PGC becomes pervasive throughout the Frontier	52 PF	18.2	4.45		15.64	246.84
33 Exploration vessels lost, piracy plays a role	51-18 PF	18.4-25	4.5-6.15		16.1-31.28	247.28-261.8
Depredations of pirate fleet under Hatzk Nar increases	24-18 PF	23.8-25	5.85-6.15		28.52-31.28	259.16-261.8
First Common Muster Called	19 PF	24.8	6.1		30.82	261.36
Battle of Timeon and 1st Common Muster disbanded	18 PF	25	6.15		31.28	261.8
Sathar War begins with invasion of Truane's Star	3 PF-0 FY	28-28.6	6.9-7.05		38.18-39.56	268.4-270.16
Second Common Muster commanded by Morgaine	3 PF	28	6.9		38.18	268.4
War declared over though ground operations continue	0 FY	28.6	7.05		40.02	270.16
Organization of the UPF, Space Fleet, & Council of Worlds	1 FY	28.8	7.15		40.48	270.6

CONCERNING HOME WORLDS FOR THE CORE FOUR

On page 73 of the Remastered Alpha Dawn rules it says,

"Star Frontiers adventures take place in an area of space called the Frontier Sector, or simply the Frontier. The Frontier contains 17 inhabited star systems, with a total of 23 colonized planets. Some of these planets have been claimed and settled by only one of the four races, while others were set up in cooperation and have mixed populations."

There is the unstated implication in the above quote that the Frontier is not the only sector of known space. Seeing that the game was set up as a "Wild West" game in space it does make sense that there would also be a "back East" analogue in the setting or simply a sector where the core four races have some or all of their home planets. This "back East" sector would have a greater degree of civilization that hinders the wild freedom and adventure that the Frontier encourages. Even the name, Frontier Sector, suggests that there must be other sectors for the Frontier to be the frontier for.

On the other hand when the original game was released it only had the self contained jump routes that made the Frontier a little microcosm. There were no jump routes that led "back East" to the home worlds. The abandonment of the game by TSR meant that other sectors were never detailed. As a result, I believe most of us played the game from the point of view that the Frontier Sector was all there is of settled space, at least as far as the core four races were concerned.

In this work I've taken the view of the Frontier Sector as being the only sector in the vicinity that contains a major civilization of the core four races. Humanity's and the dralasite's home worlds are lost some where in space to these races. The yazirian home world has suffered a major astronomical event and destruction that necessitated their exodus to the Frontier. The vrusk evolved in the Frontier and their home world is part of the setting.

The home world for humanity was easy enough; I consider it to be Earth. The comment in the Alpha Dawn book concerning another race of humans elsewhere in the galaxy evolving separately from humans on Earth never appealed to me. So if you reject that statement then logically the humans in the Frontier must have originated on Earth. How they got to the Frontier could be explained in a number of ways, anything from alien abduction to dimensional portals.

I chose to make it an accident of space travel. In space, the smallest thing going wrong can have dire consequences. In this case I used void travel. Not knowing about its existence, humanity planned a

colony expedition to another star system. Using cryo-sleep they were unaware that their ships entered void space. This circumstance does a number of things; it takes a group of humans an unknown distance from Earth, cuts off contact from Earth and allows me to establish humanity in the Frontier without anything more than minor cosmetic changes to the setting.

There are three main benefits to having Earth out there but not in contact with Frontier humans. Firstly, no consideration needs to be given to the political entities on Earth; China, USA, the EU and etc. We can simply create the political entities we desire for the Frontier and ignore the complications of extrapolating the political realities of Earth projected into the future. Secondly, having Earth out there lets us embrace and use 6000 years of Earth history, culture and literature in the game. Without Earth existing in the setting, a statement like, "...he's the Napoleon of the Yazirian Clan Wars..." would be illogical. Finally players can opt to use a known ethnicity from Earth to bring their player character to life, like French or Italian, even using a dramatic accent and voice when speaking as the character. You could of course not include Earth in the setting but I think that would limit your options.

The vrusk home world was trickier. There is only one high density population world in the Frontier with vrusk as the major component of its population, Fromeltar. Admittedly, dralasites are also a major component of that population too and the names of that system and its planets sound dralasite-ish when compared to Dramune, another dralasite dominated system. However, the setting material lists Kist'-Kar, which is one jump away from Fromeltar, as a vrusk colony controlled by Fromeltar. This is the only system in the setting that is explicitly stated to be a colony controlled by another system. The implication being that the vrusk have been active on Fromeltar for a long time and that it's a well established and matured political entity.

Establishing Fromeltar as the home world of the vrusk is actually a significant change but in the end it would produce a setting identical to the original setting. As for the dralasite sounding names for the vrusk home system and the presence of dralasites as a major component in its population I chose to explain that through quirks of history.

For dralasites there were a number of ways to go; home world lost in the depths of space, choose one on the map, or chart one that is off the map but near enough to travel too. Dramune would make a good home system as the name sounds like something a dralasite would call his star and the main planet has a high population density. I needed to explain some details about Fromeltar and the books suggest that the vrusk made contact with the dralasites so they got the "lost in the depths of space" option but with a new wrinkle to make it different from humanity's story. The dralasites would be discovered on a drifting ship and they have no memory of their past.

This makes it a mystery to be unraveled (or not) by each GM. This circumstance could be used to explain the race's propensity for philosophical investigation. As a race they are concerned with the big questions of; who am I, why am I here, how did I get here, and what is my purpose. I feel that a race awakening to brave new world with no history or past would, as a race, obsess over those questions. Not having a past also gives us a dralasite culture with no religion as well, which feels right for this race.

Having the vrusk discover and revive the dralasites means that they would naturally settle on the vrusk home world first. At the time that dralasites came to Fromeltar there would be no Pan Gal language or polyvoxes, thus the dralasite names for the star and its planets would have been developed as they could not pronounce Vrusk language. This let me explain the dralasite names for an essentially vrusk system.

Lastly we have the yazirians. The explicit statement in Zebulon's Guide, "270PF Yazirians Entered the Frontier" suggested that they lived outside and sent explorers just prior to colonizing the region of the bottom left of the map. The Vast Expanse is in that direction and though the expanse is a region of few stars it is not a region devoid of stars. So I placed their home system in the Vast Expanse. Because yazirian society is clan based, I assumed that they would be naturally traditional and conservative and unlikely to leave the home grounds of their clans in any great numbers. For that reason I went with the 'exodus' to leave a dying system and seek out a new home. This storyline dovetails nicely with the detail that the mega corporation GODCo is the Frontier's premier terraformer. A race fleeing the natural destruction of their home world would desire to save as much as they can so that they invest heavily in making their new planets into a paradise like garden that reflects the idealized beauty of the planet of their nativity. Upon latter reflection I don't see the necessity of "destroying" the yazirian home world. It could be worked into the setting as a distant system deep in the Vast Expanse that is possible to visit, though the trip is dangerous. Under that circumstance the yazirians in the Frontier could be portrayed as Pilgrims seeking religious freedom in a new world, something that would soften the Family of One's image a bit. This would make an interesting storyline to explore as well.

Despite the above, I've stuck to my original storyline of the yazirian home system experiencing a disaster that necessitated emigration to the Frontier for one important reason; I'm a huge fan of the "Yazirian Clans" article from Star Frontiersman #8. It is easily one of my top 10 favorite articles yet I had one minor problem with it. Each clan was limited to a particular planet and it seemed odd that you would not have a clan that had members settled on two or three planets. Having a government organized refugee fleet deliver whole clans to their new homes allowed me to explain that detail in a satisfactory way.

NOTES ON CALENDARS AND TIMELINES IN THE FRONTIER

Both the vrusk and the yazirians maintain calendars and histories that chronicle centuries of time. Before the end of the hive system each hive had its own calendar; the vrusk calendar presented here represents the first authoritative calendar for the whole race. Similarly the yazirian imperial calendar started with the unification of their planet under the Warhon (loosely translates emperor, general, and clan chief of clan chiefs). The imperial yazirian calendar, also known by YoW for Year of the Warhon, was used until the rise of Clan Anglan and its control of the Family of One. A religious calendar is now used by the yazirians in the Frontier based off of Hentz's year in the Araks system which is also referred to as Year of the Family (YoF).

Some dralasite intellectuals have made an effort at maintaining an exclusively dralasite calendar since their awakening in the Frontier but few of that race give it any consideration opting instead for the more popular calendar of Galactic Standard Time (GST).

Humanity's histories are a mixed bag at best. For the most part humanity follows the GST calendar. Most human colonized planets also maintain their own local calendars beginning with the colony's founding at year zero. Clarion's calendar in the White Light system began with the drafting of the planet's constitution not its colonization.

The early days on Clarion were desperate indeed and no consideration was given to ephemeral things like history. After Captain Leonine's successful coup displacing the other ship captains and their rule by committee, he instituted sweeping changes that saved the floundering colony. He proposed a constitution but the continued opposition of the displaced leaders led the rank and file members to demand that he retain the executive position. As a compromise they adopted a constitutional monarchy empanelling a House of Commons and House of Lords. The members of the House of Lords came from the embittered and displaced leaders which induced them to sign off on the new constitution. Naturally the House of Commons has historically been the monarch's strongest support. At the crowning of King Leonine I, Clarion's calendar began with the first year of his reign.

To further complicate things on Clarion, the colony's first official historian numbered the three years before Leonine's crowning as PL 3 through PL1 without a year 0. Later historians corrected this and re-designated them PL 0, PL 1, & PL 2. The debate over the proper numbering has been waged largely by academics but the small confusion over dating created contradictory records and has complicated research into the early days of the colony.

For this work the various timelines were determined by multiplying the length of day (for the planet concerned) times the length of year. While the length of day comes

from the rule book the length of year was extrapolated from the given astronomical data. The length of individual years was determined in total number of hours and compared to GST as a percentage to compute the various timelines. Galactic Standard Time uses 20 hour days and a 400 day year for a total of 8000 hours. Minotaur's calendar has 2,659 days of 15 hours for a total of 39,885 hours. Clarion's calendar has 2,988 days of 50 hours for a total of 149,400 hours. The Year of the Family (yazirian religious calendar) is based on Hentz's year of 700 days of 25 hours for a total of 17,500 hours. The Year of the Warhon (yazirian imperial calendar) is based on Yazir, the yazirian home world's year of 290 days of 22 hours for a total of 6,380. The vrusk's calendar is based on Terledrom's year of 306 days of 60 hours for a total of 18,360 hours.

ADVENTURES IN THE EARLY FRONTIER

The Age of Colonization, as it is some times called, was an exciting as well as anxious time for all of the Frontier's races. The vrusk faced stunning societal changes due to contact with other races. The dralasites pondered and wrestled with their place in the universe trying to understand meaning of their existence. Yazirians faced the destruction of their civilization and witnessed vast changes in their society. Humanity lost contact with the planet of their nativity and survived their transplantation to the Frontier by the skin of their teeth.

This was a time of few starships owned mostly by planetary governments and crewed largely by a single race. Space travel is dangerous and Astrogation is a fledgling science with a high probability of "miss jumping." Void capable ships are insanely expensive and generally small in size.

Each race has its own currency, language, calendar and trade standards. Economies blossomed in this environment and enterprising individuals who discovered ways to open new markets among the newly contacted races became fabulously rich. Pan Galactic Corporation was founded and its visionary CEO recognized the need for a Frontier wide standard of currency, a trade language and a standardized calendar.

Despite the fear and anxiety gendered during the founding of a new colony most races have a positive attitude and a good feeling about their future. Contact with other races has led to rapid scientific development and an exponential expansion of knowledge.

Adventurous individuals can expect employment in government and private sector exploration services, fledgling militia organizations, or on the ground floor of future mega corps as they struggle to carve out market share. Colonized planets can be very dangerous since much of the surface is virgin territory with many hidden dangers and the colonizers remaining clumped together in enclaves. There is talk of organizing a cadre

called the Brotherhood of Spacers and certainly other cadres are in the organizational stage. With little centralized authority the opportunities for criminals are wide open. Piracy is on the rise due to the high cost of Void capable craft and the ease with which they can be disposed of.

Practical suggestions for adventuring during this period:

- » Limit the available equipment to just the Alpha Dawn equipment list but possibly increase the cost of lasers or exclude lasers for the early days. Another option is double the SEU used for each d10 of damage. For instance, 2 SEU will cause 1d10 damage while 10 SEU will cause 5d10 damage.
- » During first contacts adventures not every race will have all of the tech on the equipment list; humans will certainly have auto pistols but possibly not needler weapons; flavor could be added by giving each race a distinct tech like gyrojet weapons for yazirians, sonic weapons for vrusk and etc.
- » Limit known space and jump routes to the Alpha Dawn map minus the Volturnus system (though that system could be discovered by the player characters)
- » Increase the availability of chemical fuel system ships and make void capable ships scarce.
- » Include role play elements that suggest some anxiety over rapid change and displacement of the weak and powerless.
- » Remember, most planets have been only been explored by mapping from orbit making them rich environments for adventure, explorers will be able to name what they discover.
- » Language would cause communications issues. Words and gestures may cause diplomatic incidents, agreeing on trade costs would be problematic, etc.



COSMIC CATASTROPHES

By Tom Stephens

Editor's Note: This article is the first in a series Referee's can use in just about any setting. I expect next issue there will be a few adventures and plot hooks submitted.

Questions? Write to the Star Frontiersman at submissions@starfrontiersman.com

When giving public presentations on astronomy, Clyde Tombaugh was often asked, "Why aren't there more collisions between planets and other objects?" His reply to that common question was simple: "Because space is very, very large and the planets are very, very small." In other words, you have to have very good aim to get things to collide.

To put the scale in perspective, consider this. If the Sun were the size of a basketball, the earth would be the size of a pea, orbiting about 105 feet away. And Jupiter would be the size of a golf ball another 450 feet further out. And Pluto, the once planet, now ice dwarf, that Clyde discovered, would be the size of a BB at an average distance of ~4230 ft (~0.8 miles).

That isn't to say that collisions aren't possible, they do happen, it's just that for any give system, the chances are, well, astronomically small. However, we are talking about a large galaxy here and somewhere, at some time, any type of collision or catastrophe could occur.

This is the first in a series of articles that describe the possible results and impacts of catastrophic astronomical events that you could use as background or events in your campaign. Anything's possible, but remember, these events are rare, only once in a million years (or longer). To maintain a thin patina of reality, if you use one of these events in your universe, don't ever use it again. They are one-off events that shouldn't be repeated during any given millennium (at least).

With that introduction and word of caution it's time for the first of our cosmic catastrophes.

INTERSTELLAR INTERLOPER (BROWN DWARF)

You may recognize this one from elsewhere in the issue. The idea for this particular event came up in a brainstorming chat session where we were looking for ideas on what happened to make the Yazirians flee their home world. We needed something drastic but didn't want to blow the planet up or smash something into it (that is so cliché). We wanted the planet to still be around when it was all over but (very possibly) uninhabited or uninhabitable. It also had to be something that gave the Yazirians very little warning. What we came up with was a close encounter with a wandering brown dwarf that passes through the system and disrupts the orbits of the planets.

A brown dwarf is a small, failed star. Brown dwarfs have masses ranging from 10 to 80 times the mass of Jupiter or 0.01 to 0.08 times the mass of the Sun. The boundaries are a little fuzzy on both ends but that is the general range. While relatively massive, at least compared to planets, brown dwarfs don't have enough mass to maintain the pressure and temperatures in their cores to sustain nuclear fusion and so never become full-fledged stars. It requires more than 0.08 solar masses for that to occur.

Instead, brown dwarfs give off light due solely to energy released from the slow gravitational contraction and cooling of the gas that they are made of. Because of this, brown dwarfs slowly dim over time and an old brown dwarf will be much dimmer than a young brown dwarf of the same mass. In fact, most of the radiation of a brown dwarf is not emitted at visible wavelengths but rather in the infrared portion of the spectrum. This means that to the unaided eye and even to most detector technology we had until the last couple of decades, they are very, very faint. While theorized since the 1950's, a brown dwarf was only actually observed for the first time in 1995!

This gave us exactly what we were looking for, something faint but relatively massive that would sneak up on the Yazirian homeworld and wreck havoc as it passed through.

EFFECTS OF THE ENCOUNTER

Despite the potential for disaster here, this encounter is not guaranteed to actually cause any problems. Remember Dr. Tombaugh's comment: "Space is very, very large and planets are very, very small." It is entirely possible to take a smallish brown dwarf, pass it at a reasonable speed through the stellar system, and have very little impact on the system other than there being a very bright object in the night (and possibly daytime) sky for a few decades. In fact, the first few times I tried to simulate this encounter that is exactly what happened.

A CLOSE ENCOUNTER OF THE BORING KIND

Okay, so that is possible effect number one. The object passes clean through the system and while it tweaks the orbits of all the planets somewhat, especially the ones it passes closest to, it doesn't really do anything catastrophic.

Sure, the length of the year will change a little, either longer or shorter depending on exactly where the brown dwarf passes through the system at, and that orbital change will have an effect on the climate. But the effects will be small and a technological species should be able to survive. Some biomes will change and habitats will be destroyed and some species on the planet may even become extinct. But it will be a gradual change, not something to abandon the planet for. It simply becomes a major historical event.



BROWN DWARF (JEFF BRYANT)

That being said, it would still be a spectacular event. If nothing else, the astronomers would have a heyday with the opportunity to study this type of object up close and personal. If it passed through the outer portions of the system, it would appear as an object in the night sky that slowly increased in brightness and then faded away over several decades as it moved across the sky. If it passes through the inner system, it will become very bright and resolve into a disk like the sun and moon. It could even be visible during the day. A brown dwarf is roughly one to two times the

diameter of Jupiter (which is 10 times the diameter of the Earth) so it could potentially be very large in the sky.

Passing through the outer system, the brown dwarf would have little to no effect on any habitable planet in the inner system. However, if it passes through the inner system, there will definitely be some short term climactic effects in addition to the long term ones that are a result of the slightly disturbed orbit. Despite being dim, they still give off a lot of energy. The surface temperature of a brown dwarf ranges from about 2200 K for the brighter/bigger/younger ones down to 750 K for the fainter/smaller/older ones.

This encounter will last for several decades at least and, especially during the time of closest approach, that extra energy will have a warming effect on the habitable planet (or any other planet that it passes close to). How much depends on how close it gets and how hot the brown dwarf is, but you could expect the average temperature on the planet to go up by a couple of degrees. This would be enough to melt ice caps and raise the average sea level, similar to what we are experiencing on Earth today with global warming. However, this is a short term effect and as the brown dwarf moves further away, the effects will diminish back to normal levels.

You will get this effect if the brown dwarf passes through the outer system at almost any angle or speed. If it passes through the inner system, this effect is most likely when the relative speed of the brown dwarf is high or it comes through nearly perpendicular to the plane of the system. Other combinations give the next possible outcome.

SYSTEM DISRUPTION

In this scenario, the brown dwarf passes through the system at a shallow enough angle, or slow enough, (or both) that its gravitational interaction with the planets in the system seriously messes up their orbits. This can occur in three different ways.

First, the eccentricity of the orbits will be increased. Eccentricity measures how circular the orbit is. A perfectly circular orbit has an eccentricity of zero. An eccentricity of less than one means the object is on an elliptical orbit around the star. An eccentricity of one indicates a parabolic orbit (one on which the object just escapes the system) and an eccentricity greater than one represents a hyperbolic orbit where the object is not gravitationally bound to the star. Typically, planets have very small eccentricities. In our solar system, all of the planets, with the exception of Mercury, have eccentricities less than 0.1. That is still so close to perfectly circular that only Mars's orbit (with $e=0.0934$) is noticeable as being out of round by the human eye if drawn to scale.

A brown dwarf passing through the system would seriously alter the eccentricities of the planets. Just about anything is possible (see sidebar for some simulation examples) but ending up with eccentricities in the 0.1 to 0.3 range for many of the planets is not

unreasonable. In one of my simulations a planet ended up with an eccentricity of 0.65! In the end, the planets that the brown dwarf pass closest to will usually have the greatest variation.

So what does this mean? Well, the more eccentric the orbit, the greater the variation in the distance between the planet and the star. A planet like the Earth, with an eccentricity of 0.0167 has very little variation in the distance between its closest point to the sun (periapsis) and its most distant point (apoapsis). As a planet's orbital eccentricity increases, this variation grows much larger. The variation for the earth is only about 3.4 percent. For an eccentricity of 0.1, that grows to a variation of 22% and at an eccentricity of 0.33, the planet is two times further away from the star at apoapsis than it is at periapsis. Since the energy from the star falls off as the distance squared. That means that for the planet with the eccentricity of 0.33, the amount of sunlight and energy received varies by a factor of four over the course of the year. The summers may be warm, but the winters will be very, very cold.

Next, and related to the first is that the size of the orbit will change. As the eccentricity changes, it will also cause a change in the average size or semi-major axis of the orbit. Technically, the semi-major axis is half the distance between the periapsis and the apoapsis. For a nearly circular orbit, this is just the average radius of the orbit but as the eccentricity of the orbit increases, it becomes more elliptical and the semi-major axis is just half the longest distance across the ellipse.

Finally, the inclination of the orbits will be changed as well. This is a measure of how tilted the orbit of the planet is to some reference plane in the star system. In our solar system, that reference plane is the Earth's orbital plane. In a newly discovered system it might be defined as the average of the orbital planes of the planets. Typically, all the planets of a star will be in orbits very close to this orbital plane. For example in our solar system, all of the planets' orbital planes are within 3.5 degrees of the Earth's (excepting Mercury which is inclined 7 degrees). In the simulations in the sidebar this was greatly disrupted and some of the planets had inclinations of up to 50 degrees.

So what does this mean for the planets? Primarily, the change in eccentricity and semi-major axis will have potentially profound effects on the planet's climate. What was once a tropical paradise could be turned into a raging inferno or an ice ball. Or it could vacillate between the two as it travels on its now eccentric orbit.

It could even be that after the encounter, some of the planets are on crossing orbits and a planet that was once further from the star spends some of its time closer to the star than a planet that was nominally closer before the encounter. The chances of an actual collision are very slim as the chances that the orbits actually intersect in three dimensional space is very, very small.

The change of the inclination of the orbit will have no real effect on the climate or conditions of the planet. However, it will change the apparent paths of the other objects in the sky as seen from the planet. The star will pass through different constellations and the other planets will follow new tracks through the sky as they move on their disrupted orbits as well.

Other effects of this scenario are similar to the ones described in the proceeding section, such as short term climatic change and the appearance of the interloper in the night and daytime skies. In an extreme case of the system disruption scenario, one or more of the planets may end up with a final eccentricity greater than one. That brings us to the next possible effect.

PLANETARY EJECTION

In this encounter, all of the effects in the first two have still occurred but after all of the dust has settled, one or more of the planets in the system have ended up with an eccentricity greater than one. These planets have been given such a gravitational boost by the interloper that they are no longer bound to their home star. This planet is now on a trajectory that will take it forever out of the star system and into interstellar space. For this to happen, the interloper will need to pass relatively close to the planet you want ejected. This will make the short term climate variations very extreme and the planet will get very hot. Typically, it will be easier (or at least not require as close an encounter) to eject planets further from the home star as the gravitational influence of the star is smaller the further out you are.

Complete ejection from the stellar system probably won't happen immediately; it may take several years or decades to move well beyond the reaches of the star and it may even make a close pass by the star on its way out. Depending on the exact trajectories of the planet and interloper, the planet could be flung out in any direction, heading directly out of the system or sent inward toward the star and passing through the inner system on its way out. In the end, however, it will eventually drift away from its home system into the blackness of interstellar space.

You can image the effects. Eventually, the planet will freeze over and become a cold lifeless world. How long this takes depends on how fast it is moving but it will only be a matter of decades before the freeze out is complete unless the planet has some internal source of energy that can delay it. If you took the Earth and just barely gave it a little more than escape velocity (42.1 km/s) directed straight out away from the sun, it would take less than one year to get out to the orbit of Jupiter and about ten to get out beyond Neptune. So within a decade it would be a very cold place. If you gave it a bigger kick (say 60 km/s), it would be out to Saturn in one year and in ten would be more than 90 AU from the sun (3x Neptune's orbit, well into the Kuiper Belt)

IMPACT!

The last possible scenario is so unlikely (remember "Space is big, planets are small") that I would personally never use it. However, it is included here

for completeness. In this case, whoever fired the marble had perfect aim and instead of the interloper making a close pass by the planet and ejecting it, the interloper actually hits the planet in question.

You can guess the result; total destruction. The exact details will depend on the relative masses of the brown dwarf and the planet but in any case, there will be no planet left. It will first be burned to a crisp as the brown dwarf approaches and then ripped apart as the two objects collide. If the planet is a large Jovian (say a few times the mass of Jupiter) and the brown dwarf is small, the collision may result in the destruction of both objects and a cloud of dust and gas strewn through the system along the path of the brown dwarf. For a terrestrial planet, however, the brown dwarf won't even notice and it will just be swallowed up as the interloper continues on its way.

Game over.

DETECTING THE BROWN DWARF

The question now remains, how much warning will you have? The answer to that depends on a lot of factors, not the least of which is the age and mass of the brown dwarf. The older or smaller the brown dwarf, the cooler it will be. And the cooler it is, the less energy is emitted at optical wavelengths as the emission peak shifts further and further into the infrared.

For this case study, we will assume a 1 billion year old (that's fairly young) brown dwarf of 40 Jupiter masses. Current models tell us that this object will have a temperature of about 1100-1200 K and a spectral classification of T3-T5. And we'll assume that it is traveling at 50 km/s toward the star system.

So what does this mean for detection? Since the brown dwarf emits almost exclusively in the infrared, it will be very, very dim to the unaided eye and will require an infrared detector to really pick it up. As far as I know, objects of this spectral type have no known optical magnitudes. Younger, brighter brown dwarfs, in the L spectral type have visual magnitudes in the range of 20-22. So for our interloper, we'll assume that its absolute visual magnitude (magnitude if it is 10 parsecs away) is 24, although it may very well be that the true optical magnitude is more like 25-26. Out in the infrared its absolute magnitude would be about 14.5 (remember, in the magnitude scale, smaller is brighter).

The faintest objects that are visible to an unaided human eye are the around 6th magnitude. It varies a bit from person to person but that is typically the faintest a person can see with the unaided eye in a dark sky. As such, there are about 5500 stars visible in the sky from earth that are 6th magnitude or brighter. Since the Yazirians have better low light vision, I'm going to assume that they can see fainter objects in their night sky. I'm going to assume that they can see down to 7th magnitude (2.5 times fainter). On earth this means that there would be about 16,500

objects that they could see, three times as many as us lowly humans. They would have a very busy night sky to look into.

So what about our interloper? Just how close would it have to get in order to be visible to the unaided Yazirian eye? Well, to just reach the limit of the Yazirian detection, 7th magnitude, it would need to get to within about 820 AU. Or about 20 times the distance out to Pluto. And that is just to be barely visible. Now that may seem fairly far away still, but traveling at 50 km/s, that is only 78 years away from closest approach to the star! And that is for an object that is barely visible and probably wouldn't be noticed. People probably wouldn't even start paying attention to it until it reached 6th magnitude (at a distance of ~515 AU and only 49 years away). At that point someone may realize that it was recorded at a much fainter magnitude only 25 years earlier. If they didn't chalk up the first recorded magnitude as an error, they might start to watch it more closely. By the time it reached 5th magnitude, it would be a noticeable object in the sky but at that point would only be ~325 AU and 31 years away. Unless the society was already well industrialized with a vibrant space program, it would be too late to really do anything about it.

So if we have to rely on purely visible detection with the unaided eye, we're in serious trouble, at least with an object as faint as we're assuming it to be. If, on the other hand, its absolute magnitude is two magnitudes brighter (22 instead of 24), the 5th magnitude warning time becomes 80 years and maybe you could focus your technological development to getting your species off the planet and out of the system.

So most likely, the first detection that sets off alarms would be the first infrared survey of the sky. One would have to assume that a visible survey had been done. But since the brown dwarf is faint in the optical, it might not have garnered any attention in the optical survey. Even if it was 10th magnitude at that time, it would be one of hundreds of thousands of objects detected and most likely wouldn't be followed up. If it was 10th magnitude, it would be about 3300 AU (and 310 years) away. At 9th magnitude, still one of several tens of thousands of objects, it would be 2060 AU and 195 years away. And of course, the first few "all sky" surveys usually aren't and only cover a fraction of the sky so it could be missed the first time around.

So let's assume it gets detected at 9th magnitude in an early all sky survey. No one really pays any attention to this object and life goes on. Some years later (on earth, it was 12) a preliminary infrared survey would be conducted and that is when the fun would begin. In this survey, the object would be bright, very bright. While there would be other objects with the same infrared brightness, they would also be much brighter in the visible. Thus when the optical and infrared catalogs were compared, this object would stand out as an anomaly and would be followed up and its spatial motion would eventually be detected. Just how long that would take would depend on the exact characteristics of the detectors available and how well

the theory of brown dwarfs had evolved, but probably only a decade at the most.

It also entirely possible that the object would not make it into the first IR catalog as it was in a part of the sky not covered, in which case it might be several decades later before it was discovered. On Earth the first IR sky survey was published in 1969. This would have detected the object if it was in the part of the sky observed. If not, it wasn't until 1999 that the next survey was completed. Similarly for the optical surveys, the first was completed in 1958 but the second wasn't done until the 80's and 90's and neither of those covered the entire sky.

So assuming you detected it optically at 9th magnitude and then 10 years later in the infrared (it would be 2nd magnitude there) and realized that you had a strange object. It might take a few years to a decade to finally determine what this object was and that it was headed towards you. At that point you'd have about 175 years until closest approach. You need to deal with all the clan wars, develop spaceflight and then interstellar flight of some sort in order for your species to survive. If this had happened on earth and had been detected in the first Palomar survey (1958) and Two Micron Sky Survey (1969), we'd have about 140 years left to make it to the stars.

CONCLUSION

The passage through a star system of a brown dwarf can have a variety of both minor and catastrophic effects on the system. At the very least, it will perturb

the orbits of the planets and could possible eject one or more of them into interstellar space.

This event would be completely catastrophic for a pre-industrial society. Without advanced technology and capable optical and infrared detectors, the society would probably have at most three decades of warning if they were really paying attention to the night sky (think early in the 18th and 19th centuries). Otherwise, they would probably have even less.

For an advanced technological society, you could potentially have hundreds or even thousands of years of warning as the high sensitivity detectors could detect and classify the object long before it became a threat. This would provide ample warning and allow for the focused development of technologies to assist in surviving the encounter.

The most interesting situation from the point of view of telling as story or game setting is for the object to be already well on it's way toward the encounter as the culture begins to develop it's advanced technology. As they first turn their advanced detectors to the sky, the interloper is discovered and recognized for what it is. However, the society is currently powerless to do anything about it. With only one to two hundred years advanced notice, the presence in the sky of the interloper serves as a focus to the technological development as effort, energy and resources are put towards advancements that will allow the species to survive the oncoming disaster.

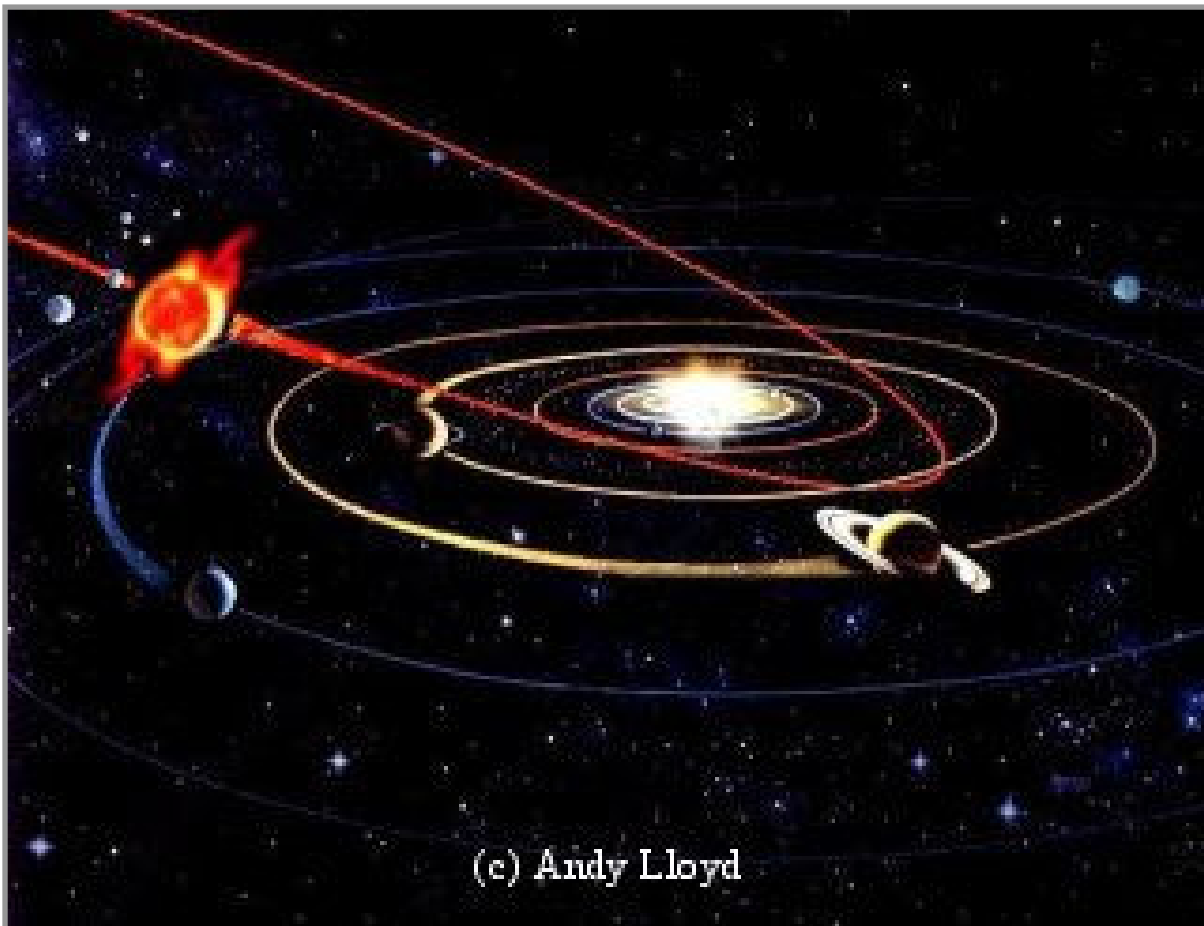

(c) Andy Lloyd



An artist's impression of a low mass dwarf, courtesy NASA/ESA/G Bacon (STScI)

SIMULATION SIDEBAR

Just for fun and to see what would happen, I ran a couple of simulations of a brown dwarf passing through the Solar System. For simplicity, I started all eight planets (plus Pluto) on circular orbits all in the same plane (eccentricity almost equal to zero and inclination exactly equal to zero). They were given their actual semi-major axis distances from the sun and true values for orbital velocity, mass, etc.

The interloper was a 46.86 Jupiter mass brown dwarf. I ran quite a few different scenarios (it only took about 2 minutes to do 1000 years of simulation on my computer) but present here just the first two. In one case (vertical impact), the brown dwarf is coming in from directly above the plane of the solar system and would pass somewhere inside the orbit of Mercury. The second scenario (horizontal impact), the brown dwarf is coming in just below the plane of the solar system, less than a quarter of an AU below the plane and parallel to it. The included tables show the relevant statistics of the solar system (semi-major axis, eccentricity, orbital period and inclination both before the encounter and after the two scenarios.

Table 3: Initial conditions

Planet	Semi-Major Axis (AU)	Eccentricity	Orbital Period (years)	Inclination (degrees)	Periapsis (AU)	Apoapsis (AU)
Mercury	0.387	0.000	0.241	0.0	0.387	0.387
Venus	0.723	0.000	0.615	0.0	0.723	0.723
Earth	1.000	0.000	1.000	0.0	1.000	1.000
Mars	1.524	0.000	1.881	0.0	1.524	1.524
Jupiter	5.198	0.000	11.851	0.0	5.198	5.198
Saturn	9.536	0.000	29.449	0.0	9.536	9.536
Uranus	19.189	0.000	84.059	0.0	19.189	19.189
Neptune	30.058	0.000	164.797	0.0	30.058	30.058
Pluto	39.480	0.000	248.064	0.0	39.480	39.480

Table 3: Final conditions – Vertical Impact

Planet	Semi-Major Axis (AU)	Eccentricity	Orbital Period (years)	Inclination (degrees)	Periapsis (AU)	Apoapsis (AU)
Mercury	0.359	0.089	0.216	7.4	0.327	0.392
Venus	0.767	0.101	0.672	7.9	0.689	0.844
Earth	1.187	0.147	1.292	10.8	1.013	1.360
Mars	1.434	0.078	1.718	12.0	1.322	1.547
Jupiter	6.846	0.239	17.911	17.1	5.209	8.483
Saturn	11.681	0.247	39.924	21.4	8.795	14.568
Uranus	53.710	0.651	393.628	25.5	18.734	88.687
Neptune	48.429	0.427	337.020	36.9	27.740	69.118
Pluto	42.705	0.106	281.034	48.6	38.347	47.463

Table 3: Final conditions – Horizontal Impact

Planet	Semi-Major Axis (AU)	Eccentricity	Orbital Period (years)	Inclination (degrees)	Periapsis (AU)	Apoapsis (AU)
Mercury	0.265	0.444	0.137	1.5	0.148	0.383
Venus	0.644	0.182	0.517	1.4	0.527	0.762
Earth	1.946	0.479	2.715	2.5	1.014	2.878
Mars	1.594	0.150	2.012	2.3	1.355	1.832
Jupiter	24.031	0.785	117.802	2.9	5.178	42.884
Saturn	6.584	0.552	16.892	5.0	2.948	10.219
Uranus	25.633	0.509	129.779	10.3	12.576	38.690
Neptune	--	1.262	--	5.8	--	--
Pluto	23.373	0.845	112.995	16.0	3.627	43.118

As you can see, in both cases, the solar system is really disrupted. Let's look at some of the specific effects for each case

VERTICAL IMPACT

In this case we get a pretty serious disruption of the system. There are two major effects. First of all the planets are pulled out of the original plane of the solar system with the more distant planets, where the sun's influence is smaller, get pulled out the most. Second, the eccentricities go way up. With the exception of the Earth and Jupiter, all the planets have their periapsis pulled in closer to the sun. All the planets have their eccentricities increased, moving their apoapsis much further out than the original orbit.

For some of the planets, especially the outer planets this is quite extreme. Poor Uranus was boosted up to an eccentricity of 0.65 and its period increases from a mere 84 year to nearly 394 years! That's a factor of almost five. Neptune's period doubles and even Jupiter and Saturn have theirs increased significantly as well.

Some other interesting aspects of this scenario include:

- Uranus and Neptune now drift significantly out into the Kuiper Belt. This means that there is an increased chance of orbital disruption of the Kuiper Belt objects that could be tossed into the inner solar system as short period comets.
- Earth is not always the third rock from the Sun. Since the orbits are now highly elliptical, Mars actually can end up closer to the Sun than the Earth at some points in their orbits, making it the third planet and Earth the fourth.
- The variation in the Earth's orbit results in almost a factor of two (actually ~80%) variation in the amount of energy received from the Sun over the course of its orbit which has increased to 1.292 years (471.9 days or about 15.73 months). When it is on the most distant portion of its orbit, the amount of energy received is 84% less than it currently receives and even at its closest point, it is about 3.4% less.
- The various (relatively large) inclinations mean that the chance of planetary collision is still quite small.

HORIZONTAL IMPACT

In this scenario, we actually eject one of the planets (Neptune) from the solar system and mess up the orbits of the rest even worse than in the vertical impact scenario. In this particular setup, the interloping brown dwarf passes fairly close to Pluto on the inbound path and then very close to both Jupiter and Neptune on the outbound track. It also passes fairly close to the Earth.

Looking at the table, you see that Neptune ends up with an eccentricity of 1.26 and is therefore no longer bound to the sun. After the thousand years the simulation ran for, it was almost 800 AU from the Sun and still going strong.

The Earth's orbit is also greatly disrupted. Its eccentricity goes to almost 0.5 and the orbital period jump up to 2.7 years and the outermost point of its orbit is out deep in the asteroid belt. And it crosses Mars' orbit which was only disrupted a little bit. At its most distant point, the total amount of energy received from the sun drops by a factor of eight compared to its current value. On its closest approach with the new orbit it is still down by about 3%. Since a planet spends most of its time in the farther reaches of an elliptical orbit, the earth would have a long, very cold winter, probably about 2 years in length with a short cool spring, summer and fall lasting about 7 months in each of its new "years".

Jupiter gets flung on to an even more elliptical orbit and spends a lot of time out in the Kuiper Belt with the potential to disturb the objects out there and send them into the inter solar system as comets. The same is true for Uranus.

Saturn on the other hand gets flung in. Its orbit now dips all the way from the outer solar system into the outer reaches of the asteroid belt. It never gets quite as close as the Earth's most distant point but there will be some years when Saturn will become a large bright object in the night sky. If it manages to hold on to its ring system, it would be a spectacular sight.

FINAL COMMENTS

I hope that gives you a feel for some of the things that can happen with this kind of scenario. Those were two fairly arbitrary initial conditions. It would be possible to cook up just about any scenario if you really wanted to.



GAME REPORT

TALES FROM THE FALCON

By Richard Rose (aka Shadow Shack)

Editor's Note: This is the second part of the **Basically Speaking** online game. The first part appeared in issue 9 page 46. We played the game using the <http://starforties.us> Game Room, an online chat and dice roller utility.

Mission Two: S.O.S.

Corporals Johann, Slade, and Tichat-Ka head for the CMS Falcon to disembark on yet another day in the space lanes. Midshipman Bluto Goorhud, their boarding party leader, greets them at the Falcon's loading deck where they are introduced to a pair of newcomers: Danyon Fenn (mH) and Gret Korg (mY). Danyon is a transfer from the Clarion Royal Guard; the land based military force under Clarion's monarchy. Gret is a former hovercyclist looking for a new lease on life. Once the introductions are complete, the crew begins to make preparations for launch.

The Falcon has been assigned to inspect an incoming Class:XII liner, a job that promises to kill the bulk of this outing. Just as Lt. Shirrah gets the Falcon's beak pointed in the right direction, Clarion Flight Control orders a Priority Epsilon threat (Epsilon is a non-aggressive threat, but a threat nonetheless). A Class:VI Pacific class freighter has dropped out of the Void, hailing from Madderly's Star. Her captain has issued a distress call, informing anyone listening that his drives have malfunctioned and he is unable to get them repaired. The craft is on a direct collision course with Clarion Station. The SS Gullwind, under the helm of Captain Garlus Tylappar, has made many visits to Clarion Station and has berthing dues paid up for the next few months. The fine craft has brought a lot of revenue to Clarion so it is important that the Marines help the crew to not only prevent a collision with their station, but to preserve the craft for future income. As the Falcon nears the malfunctioning craft, Captain Tylappar informs Lt. Shirrah that the drive motivator has been damaged beyond repair, requiring dry dock facilities to fix. Unfortunately the drive motivator is the primary controlling feature of the engines, without it deceleration is impossible.

Jr. Lieutenant M'kix Ris'z II reports that the Falcon is currently carrying a spare motivator that might work, and despite the obvious size differences, in theory at

least one drive could be restored to operational status with the scout's smaller unit. Shirrah orders M'kix Ris'z to bring the motivator down to the loading deck and have the boarding party meet him there. M'kix Ris'z and Shirrah will be assisting the Gullwind crew with the drive repairs, and the boarding party will oversee the operations as a security measure. Also, the captain reports a small load of parabatteries is in the hold and since the craft will be docking at Clarion Station for repairs, the load must be inspected.

The Falcon races to meet the disabled craft, and gets there with time to spare. The ships are soon linked by their airlocks, and the Falcon boarding party is met by the freighter's captain. Once the group is aboard the Gullwind, Garlus seems somewhat absent minded (he is an elder after all) but will quickly snaps back, apparently eager to get underway. His five Dralasite crewmembers assist the Falcon crew with repairs and replacement. Tichat-Ka joins M'kix Ris'z and they follow the Gullwind's rubbery engineer into the elevator, lugging the drive motivator along. The doors close and Bluto nods to the Gullwind's skipper, suggesting that they get on with the inspection of his hold since the disabled ship will be docking at Clarion Station.

Garlus calls the elevator and it arrives a few minutes later, and they all pile in. He takes the car down to the 'Wind's hold, and the group exits. Garlus' manifest lists si crates of parabatteries and a rocket battery weapon system, with no destination. "Personal goods?" Bluto asks. The skipper nods, as he is busy stuffing his worn pipe with some Inner Reach tobacco. Johann takes the elevator position as Bluto joins the rest of the inspection team, and begins making small talk with the elder.

"Stuff will kill you, y'know...of course modern medicine can counter that as well." Garlus looks over at Johann, and points to his chest. "A little late in the game to worry about that. Got the big C, detected it too late. Not sure how much time I have left." He begins with some sporadic coughing, but it ends just as quickly. Meanwhile, Danyon and Slade begin to open the crates as Gret and Johann look over the stored weapon system. Both are in order, nothing raises a suspicion with the inspectors.

Meanwhile, Tichat-Ka begins to install the motivator under the watchful eyes of his vruskan engineer, M'kix Ris'z II. Once it is installed, M'kix gives it a once over and say "You almost got it right, Corporal. But the couplings are reversed. Fix that and it ought to work." Tichat-Ka apologizes, explaining that he's used to smaller scale technical repairs. He switches the couplings and the Gullwind's Dralasite engineer

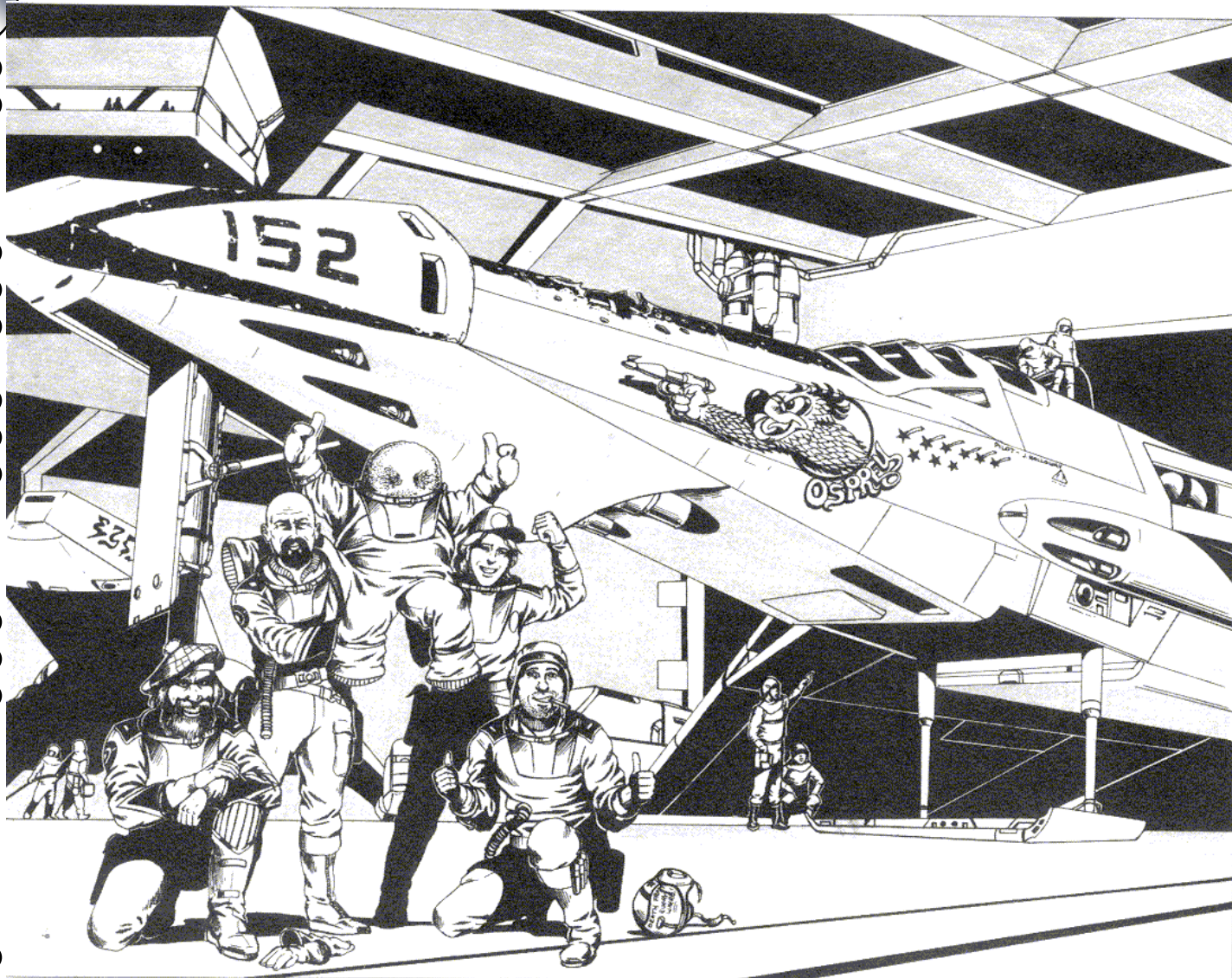

waddles over to the engineering station to run a diagnostic check. After a few minutes of data scrolling, he looks up and bellows "I think that'll do it. We're good to go, that should hold us for the trip to Clarion Station!"

"M'kix Ris'z and Tichat-Ka head back to the Gullwind's crew deck, calling to Bluto that all is well on the maintenance deck. The rest of the boarding party meets them there, along with Garlus. Once assembled on the crew deck, Tylappar informs the group about a class:X freighter that was 20-30 hours behind him that he overheard in a spacers dive at Kdikit Station that may be smuggling contraband, possibly either Ixiol or Streel provided weaponry, that is destined for the Throne City. The rogue freighter is dubbed the SS Nightshade, and Garlus informs the Falcon crew that the Dralosite owner "Dablak" is not one to be underestimated.

Several of the inspection team members gather additional information on the Nightshade, and they thank them for the tip. Garlus salutes them as they leave, and he closes the 'Wind's outer hull hatch behind them. Soon after the boarding team is buckled in aboard the Falcon, the craft breaks loose and pulls

away. The Gullwind's single drive ignites, and her skipper reports that the repair is working well. He thanks Shirrah over the subspace radio and points the Gullwind's nose toward Clarion Station. Lieutenant Shirrah calls in to Clarion Station Flight Control to report the tip, and then proceeds into deep space to meet the incoming vessel.

True to the Gullwind skipper's word, the SS Nightshade drops out of the Void 20 hours after the Gullwind is underway. Lt. Shirrah calls it in on the radio and Clarion Flight Control directs the Falcon to intercept and investigate the claims. After all, the Nightshade is registered under MalCo Enterprises, a company with reputed ties to organized crime, so any inbound loads will require extra special attention, moreso with this intel that was recently gathered....

As the Falcon closes in with the rogue freighter, a lengthy radio conversation ensues. The freighter crew claims they are not stopping at Clarion Station, nor are they carrying any cargo and as such no inspection is required. They insist that they are merely passing through, on their way to Theseus or K'tsa Kar, they haven't decided which. After a lengthy argument the freighter captain finally agrees to an inspection, telling

Shirrah that they have nothing to hide. The Falcon closes in and docks with the Nightshade.

The boarding crew is on the loading deck, and Bluto leads them to the Nightshade's outer hull hatch. A rough looking yazirian meets them at the Nightshade's hatch, and opens it to allow them inside. A Dralasite with a rich black cloak flowing over what passes for shoulders stands near the yaz. The Dralasite bellows out "Well, let's get this dog and pony show on the road, we got things to do!"

The dral hands Bluto a cargo manifest, it simply reads "No cargo obtained for Madderly's Star/White Light voyage".

The yazirian sneers and points to the elevator. "Right this way, folks." Neither seems pleasant about this unnecessary inspection; both seem anxious to get back underway.

Bluto and Gret remain on the crew deck to watch the airlock and access to their ship, the rest of the group piles into the elevator car and it descends to the Nightshade's hold.

The doors open and the group exits. Danyon, Johann, Slade, and Tichat-Ka look around the vacated hold, its floor occasionally littered with broken crate remains and an occasional mangled piece of plasticard. "Wow, whaddya know," the Dralasite interjects. "Just like the manifest says, empty!"

Danyon stoops to retrieve one of the mangled plastisheets and finds it is the remains of an old invoice. He shows it to Slade and Johann, who read the inscription: "FOODSTUFFS - Point of Origin: Inner Reach, Destination: Outer Reach" The duo both nod and Danyon drops the plasticard to the deck. Tichat-Ka appears to be pacing the hold and tapping the deck with his pistol butts.

Once finished the vrusk glances over to Johann and he nods. Johann speaks up, "We'll have to inspect your cabins next." The yazirian looks to the Dralasite, who mimics a Human expression by rolling its eyespots. "Ooooooh-kayyyy," the dral lets out. "Let's go, back into the elevator. A lot of back and forth with you guys today!"

Everyone gets on and the car returns to the Nightshade's crew deck. Johann calls Bluto on the chronocom to report nothing found in the hold and that they are returning to the crew deck to inspect the cabins. The elevator doors open and the group spots Bluto and Gret waiting, and they exit. Johann gives Bluto a whispered update as to what we found in the hold as far as the mangled invoice.

Bluto begins barking orders to the inspection team. Slade and Johann begin to search the cabins while Tichat-Ka and Danyon head for the galley. The cabins are all vacant and unkempt, with nothing out of the ordinary. Try as they may, they find nothing incriminating. Then Tichat-Ka returns from the galley

holding an empty vial and an aqua-pipe, obvious paraphenalia of a narcotic drug. Bluto nods and Tichat-Ka asks the dral/yaz duo about it. The Dralasite shrugs, but the yazirian dips his head down and mutters out "It's mine, personal use and all that." Tichat-Ka gets cross and demands where the drug is, telling them that while the Clarion Royal Marines can not impound the craft over the items, they can still issue a fine.

The yaz simply answers that he used the last dose a day ago.

Slade begins to ask if they know of a Captain Tylappar while Johann whispers to Bluto, who calls the Falcon C.O. on the chronocom.

The Dralasite acknowledges Tylappar but knows nothing of his presence in system, simply declaring that like themselves he is an independant hauler making their way through the Frontier. They have crossed paths in the past, and they merely look at him as competition.

A heated debate begins as to why Garlus might drop info on "competitors" that may be carrying contraband, but in the end there is nothing gained by this and that the Marines can do little else in detaining this vessel.

Bluto hands the Dralasite a plasticard and offers an apology, and that the Nighthshade may enjoy complimentary berthing for up to ten days at Clarion Station as restitution.

The group herd themselves back into the Falcon with a feeling of dismay, having garnered nothing and feeling taken for as fools. Lt. Shirrah meets them inside to reassure them, saying that it happens and not to let it get to them.

Gret looks back as the Falcon's outer hull hatch is closed and catches a glimpse of the yazirian in the opposite hatch, who is giving the Falcon crew a nasty look. Gret returns it with an unpleasant gesture of his own, one that Bluto countermands him for.

"At ease soldier, we don't get to win all the time." Tichat-Ka clicks off with "Give us a princess to rescue, we're pretty good at that." The witty repartee brings some welcome relief to the group, and they head back to their stations to buckle in so the Falcon can rush to its next job, a Class:XII freight hauler that just dropped out of the Void.

Richard from the Shadow Shack



CHARGE OF THE DRALASITE

By Thomas Verreault/jedion357

Author's Note: The following is an adaptation of game post from what I felt was the most exciting episode from my first on line Star Frontiers game (<http://au.groups.yahoo.com/group/BlackHandGang/>). Much is my own writing but portions are from the referee and other players. I had to edit and adapt to make it fit a fiction story format. As written in the game post it would have made for tedious reading so I've focused primarily on my own character's actions to keep the story coherent. There was no intention on my part to diminish the role of the other players but simply to tell a good story. Special thanks to our Referee, Captain Hellrazer, and the other players who made my first play by post game such an enjoyable experience. Finally, it's truly ironic that the encounter sprung on us by the Captain was from the oft neglected Basic Game and yet it was so much fun.

Suddenly wrist communicators began blaring an alarm and an emergency public broadcast, *"Alien creature has broken out of confinement at the Zoological Park! Last seen headed north! Creature is reported to have attacked its handler earlier this morning and should be considered dangerous! Stay inside! Police have been notified but a major accident on the Spaceport Expressway is occupying most of the patrols!"*

Across Port Loren, members of the Black Hand Gang nod their heads silently. The creature cannot be allowed to run loose until the police arrive. Hands reached for side arms as the scattered adventurers rose to their feet and began to converge on the City Zoo.

Doog was crossing a road headed towards food when his chronocom chirped the emergency broadcast. Freezing in mid step with one pseudo foot up, he smacked himself in the head with four arm pods. He has no weapons! Well, just smoke and tangler grenades and brass knuckles. What a fool he'd been running around decking out his laser rifle with a bayonet and other attachments and he didn't even pick up a side arm! It was Alcazzar all over again, going into combat weaponless like a target. A hysterical woman ran by him bumping two of his "elbows" knocking him off balance.

"Well, Drals bounce!" he mumbled to himself and quickly keyed the team's frequency on his chronocom, "This is Doog, I'm weaponless and one block from the zoo; anyone know where I can get a gun on the quick."

After the briefest pause the chronocom responded, "Electronics Repair."

He wasn't even sure who said it as he was already running.

Doog burst through the door of the Electronics Repair shop as Ook-A-Lug, the yazirian proprietor, was about to secure it. Slapping his card on the counter, he commanded, "I need a hand laser and 3 clips five minutes ago!"

Doog was inflating his dralasite body with air to try to seem larger and more commanding when a pocket of air squeaked out with the tell tale sound of flatulence. Suddenly, Ook-A-Lug's angry look turned to a smile as he and his assistant busted out laughing. Still laughing they threw the pistol and clips on the counter and charged his card.

As Doog sauntered out the door trying to look tough he heard Ook-A-Lug say, "Go get him killer," followed by more laughter.

He started pounding the pavement as furiously as his short dralasite legs would go, worried he wouldn't make it to the action in time. He knew he was just a lowly computer tech in an outfit of far more capable military types. It's just that since his defection from Streel on Alcazzar and going into combat with only brass knuckles he had felt like he hadn't carried his weight. It was foolish to think that way but he just couldn't help himself. It was at that moment that he heard the report over the team frequency that O Mack was hit. Redoubling his efforts he decided to try plowing through the buildings in front of him rather than go around.

He barged into a barber shop. The proprietor and two patrons were rubbernecking at the windows on the far side of the shop and had exclaimed, "Oooooo," as O Mack was attacked again by the creature.

Doog shouted, "COMING THROUGH!" Without slowing down as he charged out the opposite door. Seeing O Mack across the road he started to wave but realized his team mate's focus was on the creature. That's when Doog noticed the hydra, it was huge and slug-like and beautiful to behold, at least Doog found it so. He stood in awe gazing at it.

He hadn't realized it but his short cut through the barber shop had let him arrive in time as the team of professional mercenaries set up a deadly crossfire on the hydra. The order to fire startled Doog and his shot was a moment behind everyone else.

"Something's wrong! Our lasers don't seem to affect it!" someone said.

All around the combat zone members of the BHG came to the same realization. Despite numerous hits from laser weapons, the hydra seemed unaffected.

The familiar voice of the team's scientist came over the com, "That's not quite accurate. I've been checking the records on this particular species and apparently laser fire is reflected away by the hydra's silvery hide. However, the heat from the energy beam excites the creature's cells, causing it to bud again!"

As if in demonstration, the hydra bellowed and stretched out in all directions as more appendages sprouted from its torso at the site of each laser blast. Another half a dozen, dart throwing limbs emerge from the hydra's body as it slithered down the road spraying darts at its antagonists. Doog was on the receiving end of hydra darts as the creature continued its rampage through the streets of Port Loren.

"Great! Laser weapons are out. What do I do now?" he pondered.

Tossing a smoke grenade for cover he ducked back into the barber shop. Inside he announced in as booming and commanding a voice he could manage, "Beam weapons are not effective against it. Someone give me another weapon," and after a brief pause he raised his voice, "Quick!"

Doog knew he was being pushy and rude but he also knew that typical being behavior would be to answer him with a, "No" if he asked nicely. The yazirian barber smiled and opened a draw to reveal a set of folding straight razors. "All I have is these. Space punk style was the rage a decade ago but no one asks for that silly shave anymore."

The razors were laid out as small, medium and large but only the large looked big enough to use as a weapon. He scooped it up, folding it open and said, "Many thanks."

Before he could dodge out the door a shop patron said, "Show him the rest Harvey!"

The yazirian barber smirked while opening a closet and said, "Heh, I have this too."

Inside was a strange archaic uniform and a muzzle loading musket. "I'm a member of the Society of Creative Anachronism and I re-enact a fighter from the Yazirian Clan Wars," he explained.

Taking the musket with two hands like it was a precious vase he further explained, "She's rifled, not smooth bore so she will shoot fairly straight though a little high and to the right. The cartridge belt has twenty lead shot pre-rolled with powder and the paper wadding. It's an exact reproduction."

Doog was incredulous but it beat charging the hydra with a folding razor. At the thought of getting a fire arm Doog was ready to pump all four fist in the air but now he just wanted to scratch his head with all four pods. Yet, he had asked for a weapon and this was a weapon. Doing his best imitation of an archaic yazirian clan salute, Doog took the rifle and cartridge belt. While buckling the cartridge belt he keyed his chronocom to team speak and announced, "This is Doog I just got a firearm, over."

The barber demonstrated the loading procedures and set the uniform slouch hat on Doog's head before patting him on the head saying, "Go get him killer."

Doog did a double take as he went out the door, "What's with yazirians calling me killer?" he wondered.

The smoke from his grenade hid most of the giant slug from his view but taking careful aim with the unfamiliar weapon Doog squeezed the trigger. The loud report was stunning and kick of the weapon knocked him back two paces. He had known these things were loud but experiencing it first hand was shocking.

Another dralasite team member who had been late to the battle came chugging around the corner and upon spying Doog with the anachronism he and exclaimed, "What the..."

Doog just shrugged two of his arms at Boro, knowing the other dral was likely to tease him endlessly over this. The slug had changed directions and was moving away from the two dralasites at a speed that would make it near impossible for them to keep up. Doog's heart was sinking at that thought. First it had been Alcazar with only brass knuckles and now this with only one shot from an archaic musket that had probably missed. He was beginning to wonder what he was doing in this group of veteran mercenaries.

Suddenly a hover car piloted by Con, one of the human veterans in the group backed toward the two dralasites. Seeing Con approach with the hover car, Boro reached Doog's side and said, "You'll never hit it from here with that thing. Let's get a little closer."

Sticking out an appendage, he produced an oversized thumb as he called out to Con, "Taxi!"

In the hover car Boro asked for a sit rep while Doog opened the sun roof so he could stand up and reload the musket.

"O Mack is driving it with his automatic pistol while Gleep is taunting it with gyro jets. Sui-ling and Crisbel are back at the hotel getting more fire arms and others are trying to get in front of it by cutting through the Hub. We'll whip around the Hub and see if we can head it off up near the hospital."

Looking again in the rear view mirror Con asks Doog, "What the hell is that?"

"A firearm."

"You wish!" Boro taunted his fellow dral. Doog noticed that Boro actually had a human style smirk stretched across his face, "Cheeky Bugger! It was this or the folding straight razor; anyhow beggars can't be choosers."

As he spoke Con executed a neat 180 spin and floored the accelerator slamming Doog against the edge of the sun roof. He braced himself with two of his arms while starting to reload the musket with the other two.

At the hotel Crisbel handed Sui-Ling a satchel full of weapons while shouldering another himself and said, "Get these to the others."

"Wait, what are you going to do?"

"This," said Crisbel as he ran at the window opposite the elevator and fired his gun shattering the glass just before he dove through it.

"Show off," answered Sui-Ling at the yazirian as she ducked into the elevator. Not having skin flaps between her arms and legs for gliding she'd have to use the elevator to get down from the 109th floor.

Doog gave no notice to the yazirian gliding over a hundred meters above him as they raced along the southern portion of the Hub. Feeling oddly detached from himself part of Doog's mind wandered back to the class on yazirian pre-space literature and a poem he'd memorized popped into his head. Arms and feet brace and the wind in his face he tore a cartridge open. With a cupped a hand forming a funnel on the mussel he poured in the gunpowder and began reciting poetry, softly at first.

"Half a league, half a league,
Half a league onward,
All in the valley of Death
Flew the six hundred.
'Forward, the Clan Renegade!
Charge for the guns!' he said:
Into the valley of Death
Flew the six hundred."

The shops of the Hub were a blur as Doog squeezed the lead bullet out of its paper wrapping and stuffed it into the muzzle and all the while his voice rose a little higher.

"Forward, the Clan Renegade!
Was there a yazirian dismay'd?
Not tho' the soldier knew
Someone had blunder'd:
Their's not to make reply,
Their's not to reason why,
Their's but to Rage and die:
Into the valley of Death
Flew the six hundred."

Doog stuffed the paper wadding into the mussel and hung on as Con swerved the hovercraft around the Hub headed north opposite the Stellar Hotel. In spite of being braced Doog was violently thrown sideways. Yet he kept up his recitation,

"Cannon to right of them,
Cannon to left of them,
Cannon in front of them
Volley'd and thunder'd;
Raged at with shot and shell,
Boldly they flew into well,
Into the jaws of Death,
Into the mouth of Hell
Flew the six hundred."

Doog Luos

Terledrom, Fromeltar

STR/STA	55/45	PSA	Technological
DEX/RS	65/56	Height	1.2m
INT/LOG	60/70	Biological age*	31
PER/LDR	40/50	Lie Detection	6%
Skills	Computer:2 Beam:1; Melee:1 Physics:2		
Employer	The Voltarnus Trading Company		
Title	Technician		

*1 year 38 days in stasis between missions-at the time of the game report above.

BACKGROUND: Born to a line of famous debaters within the upper echelons of Terledrom society, Doog always felt smothered by his overbearing parentage that had predetermined his career choices for him. His family members, having excelled in the Dralasite cultural practice of debate, were at the center of Terledrom's foremost thinkers on philosophy and political theory and academia. Many had held key political positions within the Dralasite/Vursk colony and it was long expected that Doog would follow in the Luos tradition.

Doog's first escapes were through computers and the information net and the "bad" human comedians not good enough to entertain in a human colony but very popular with Dralasites. In time he became quite skilled at infiltrating computer nets. His family was pleased with his ability to research information but seriously frowned on the obvious wanderlust. Eventually they enrolled him in philosophical studies. Feeling trapped Doog often cut class to wander over to the space hub and would hack into ships' astro files to vicariously escape Terledrom. During one such hacking attempt he was caught by a Vursk freighter captain who seemed to well understand Doog's predicament and offered him a berth as a computer tech assistant. Unfortunately, the freighter was set upon by pirates on its second void jump in the Cassidine system. The local anti-piracy patrol responded but not before the entire crew, except for Doog, was killed. Since Doog had been only listed as super-numeracy cargo the freight line refused to pay him and threatened to prosecute him as a stowaway.

Nearly penniless and stuck in Cassidine, Doog jumped at the first job offer he found. Unfortunately that was with Streel Corp, on Alcazzar. Working for Streel was easily the worst job he had ever had which was why he jumped at the opportunity to join the mercenary outfit know as the Black Hand Gang hired by the CDC to "regulate" the Streel activity on that planet.

DESCRIPTION: Doog Luos is a typically short Dralasite, 1.2 meters tall with a surprisingly smooth, for a Dralasite, gray skin than lined with blue veins just visible under the skin. His eye spots are a startling shade of blue that some humans find very appealing. He maintains 3 legs for walking and 2 hands with the right being his preferred limb. Since he can generate a 6th limb he usually saves that for doing tech work: holding a light, tool or schematic. A favored joke/ gag by Doog that was first used on Alcazzar, is to stand on one hand and hold up five appendages in the air while saying, "Give Id five!" He finds it tremendously funny and continues to do it to this day despite the groans and threats of friends and coworkers.

Doog also is afflicted with the "Swiss Army Knife Syndrome" and cannot prevent himself from outfitting equipment with all of the latest gadgets and attachments. This syndrome showed up soon after Alcazzar when he sunk all his money into a bandoleer strap, scope, weapon mount, knife and krik hide carrying case for the laser rifle he acquired on Alcazzar. He's compulsive about tinkering with his equipment and will buy attachments or upgrades even if he doesn't need them.

One handing the ram rod, Doog slammed the shot home and braced for the next turn to the west but Con slammed on the brakes at the north east corner and urged his dralasite passengers to exit the vehicle with all possible haste. Boro tumbled out of the hover car while Doog continued his poetic recitation ignoring Con's order.

"Flash'd all their Blades bare,
Flash'd as they turn'd in air
Sabring the gunners there,
Charging an army, while
All the world wonder'd:
Plunged in the battery-smoke
Right thro' the line they broke;
Clan and Yazirian
Reel'd from the sabre-stroke
Shatter'd and sunder'd.
Then they flew back, but not
Not the six hundred."

The Slug hovered into view as Doog half cocked the musket and put a firing cap on the nipple. He could see Crisbel on the ground now handing out weapons to team mates who had been packing lasers earlier. The veterans were taking up positions on either side of the road and Con was revving the hover car in preparation for his suicidal stunt. The team was almost set and yet on went Doog with the poetic recitation. His voice had risen louder by this point and he was reciting with gusto now.

"Heads up! O Mack, I am incoming!" Con announced over the com before flooring the accelerator.

"Cannon to right of them,
Cannon to left of them,
Cannon behind them
Volley'd and thunder'd;
Storm'd at with shot and shell,
While winged hero fell,
They that had fought so well
Came thro' the jaws of Death,
Back from the mouth of Hell,
All that was left of them,
Left of six hundred."

Doog flexed his knees, using them to maintain a level firing platform for the musket against bumps from Con's driving. He fully cocked the weapon and leveled the barrel. The surrounding shops and building were not even a blur as his focus was on only the rifle and the looming slug. He held his fire till the best possible moment in their suicidal charge at the slug still reciting,

"When can their glory fade?
O the wild flight they made!
All the world wonder'd.
Honour the charge they made!
Honour Clan Renegade,
Noble six hundred!"

As he spoke the last line the moment had come and the hydra loomed large like a mountain. It would be impossible to miss and Doog squeezed the trigger. The shoulder stock slammed him hard knocking him back inside the car just before Con slammed the hover car into the monster.

Doog stood in the street beginning to feel battered and bruised as the adrenaline rush from the excitement of combat wore off. It was over. A crowd of civilians was forming as people ventured out to rubberneck at the carnage wrecked by the escaped slug.

"Amateurs," he muttered. He loved the human expression, 'rubbernecker' but nobody could really rubberneck like a dral could. He would have loved to show them all how it was really done but he still had Harvey's rifle and he'd promised to take care of it. From the sound of sirens Star Law was likely to be on the scene any minute and it might be best if he slipped away. Heading into the shopping center of the Hub he dog trotted toward the barber shop.

A few groups of people noticed him with the reproduction musket and started cheering and slapping him on his back having watched the action via news feed from the overhead copters. It wasn't long before he was thronged. Luckily, Harvey saw him coming and physically barred the door to his shop to all but Doog.

"Well done! How'd you like the rifle?" Harvey exclaimed as he embraced Doog.

"I couldn't tell if it shot high and to the right... I think I was lucky to even hit it."

"You did fine!" After a pause Harvey resumed, "Normally, the one who fires one of these is the one who's responsible to clean it but I'll take care of that for you my friend."

Doog came to full attention saluted and then formally presented the firearm to Harvey. The barber returned the salute with even more flourish. He was about to give back the uniform hat but the yazirian waved him off.

"You keep the hat. Say, they said on the holo news you were reciting something; what was that?"

"The Charge of Clan Renegade."

Harvey roared with laughter and extracted a promise from Doog to meet for drinks with the rest of his regiment. Doog used the far door to avoid the crowd but just before he did he said, "Hey, if anyone comes asking for who it was that borrowed the rifle could you say it was a Dral named, Boro."

With a nod and a wink from the barber Doog slipped away to go nurse his wounds.



EQUIPMENT

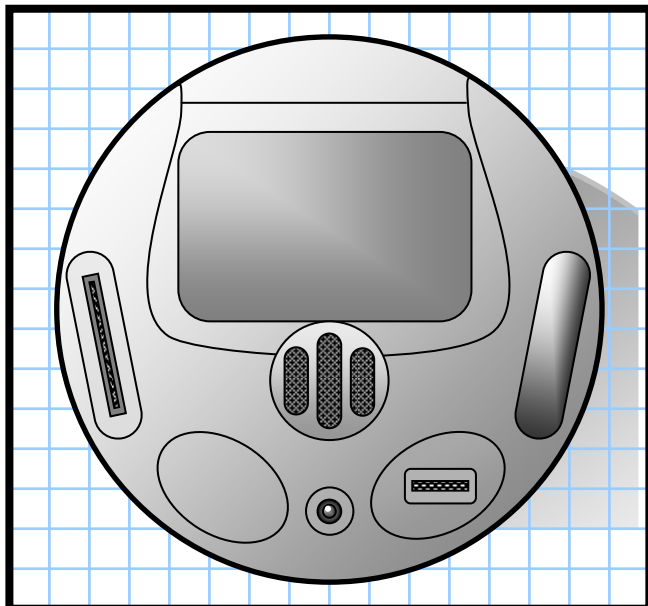

ROBOT ARCHETYPE: COURIERBOT

By C. J. Williams

Designation: AD-428

Manufacturer:	Tachton Instruments
Level:	4
Type:	Service
Body Type:	Standard (Sphere)
Limbs:	None
Number:	1-4
Move:	Hoverfan; 30 m/turn
Move Rate:	36 km/hr
Sensors:	Communications Relay
Security:	None
Power	20 SEU Rechargeable.
Source:	
IM/RS:	+6
Structure	60
Points:	
DEX:	90
PER:	54
Attack:	0
Damage:	0
Programs:	Facial recognition, messaging, bureaucracy, personality, communication, language, information storage, commerce.
Mission:	Deliver messages or provide live feeds at a fair market value.

Functions:	Record messages, relay messages, provide live feeds, encrypt messages according to requested security level, translate, recognize individual, access public records, analyze needs, advertise specialized services according to analyzed needs.
Integrated Equipment:	Flatscreen display, magnavision, holorecorder, holodisplay, homing beacon, credit reader, bot tracker, and universal port.
External Equipment:	None.
Weapons:	None.
Armor:	None.

Description: Made for all communications purposes, the spherical courierbot floats around seeking out individuals to send or receive messages. This is frequently used by advertisers to provide advertisements to random individuals customized to the activity of the individual and can facilitate transactions on the spot. But these are also handy for time-coded messages, announcements, communications, and message delivery services. Quirks are common to this type of robot, especially since it is provided a basic personality suite. These are very common in most major metropolitan areas. These bots may also be modified for surveillance and tracking. They are often mistrusted for this reason and may fall prey to attacks from those who do not want to be observed.

Despite their popularity with the military, they are easily repurposed because they have no security lock in place due to their diminutive size. For this reason, their maintenance runs high in a military complex as they are routinely checked for spybot traits.

Due to their high destruction rate, customer demand required TI to install homing beacons so that customers could find their downed robots and recover their sensitive information.

Cost: 11,000 Cr.

ALTERED MISSIONS AND MODIFICATIONS

A courierbot's programming and hardware give it a wide range of possible missions

UNMODIFIED

Even without modifications to its programming or physical components, a courierbot can perform a wide variety of tasks simply by altering its mission and functions.

Adbot. The courierbot was specifically designed for the purpose of spamming. It is thus most in its element as an adverb. No change in programming is needed to use one as an adverb. All you need to do is give it some ads and it will look for every individual it can that would likely be interested in one of its advertisements. It identifies the individual and then based on their public profile determines their interests, customizing the advertisement to their specific needs.

Beacon. A courierbot can be programmed as a beacon to inform others who pass by, or to draw authorities to rescue the party. Simply give it a pre-recorded message stating the robot's tracking number to repeat at certain intervals and have it activate its bot tracker.

Cheater. Though not mentioned in its sales package, the courierbot can be used to spy in games of cards, or for observing sports opponents in their private training. Just make sure that the robot is not found out or that it can be traced back to you.

Observer. It can be used to babysit anyone or anything. It can keep an eye on people, follow them, note their actions and reactions, and contact you if anything out of the ordinary happens. However, it is incapable of keeping anyone at bay.

Proxy. When you are unable to attend a function, you can send a courierbot as a proxy in your place. The courierbot will typically be looked after to make sure it is not tampered with while it is at the function.

Recognizer. This use for the courier robot allows lawmen and bounty hunters to identify a target without having to get in close. The facial recognition software it comes with is ideal for identifying the subject definitively, doing so at a safe distance. However, if spotted, it may be dodged, or even shot down.

Translator. The robot's broad language program allows it to translate effectively in many languages. This makes it a particularly adroit ambassador's assistant. It can translate any known language or derivative.

CONFIDENCE DRONE

Despite their talkative nature and business as a spy and courier, courierbots are specifically programmed to provide a level of security and privacy to each message. It can even be commanded to automatically assign the highest level of security to everything it records, making it the perfect trusted servant in all situations, as long as it does not get repurposed. Its credit reader also makes it ideal for conducting business. It can be of further use for those in the underworld by simply changing out its magnivision for a C-Thru Analyzer and command it to use its holoprojector to demonstrate where weapons are hidden on someone's person nearby.

DECOY

To use the courierbot as a decoy, it needs a voice simulator, allowing it to analyze and imitate the voice

of a party member. With its small size, it can move about with minimal chance of being seen. It can even be used to fool others into believe there are a lot more individuals in hiding than there really are.

HUNTER SEEKER

The hunter seeker is specially equipped with a single small syringe dart that can be used to incapacitate or even kill a target. Useful for assassinations, apprehensions, and counter ambushes. The facial recognition software makes it ideally suited for locating the correct target. You should remove the personality program for this purpose.

LIBRARIAN

The librarian variation allows the robot to connect to a database via a botlink to access information and provide relevant information. This is not so much an addition to the robot as an addition to a computer.

LISTENING POST

The courierbot can be used to hack into an enemy's communications signals. Change out the robot's commerce program for a transmission analyzer program and remove the personality program. This is also particularly useful to law enforcement and bounty hunters for tracking their prey's activities.

RELAY COORDINATOR

A courierbot is ideal for extending wireless communications over great distances. It even makes for a surprisingly good field coordinator, facilitating communications between militia and headquarters, giving an aerial view of the battle with a tactical readout, and transmitting HUD information to the soldiers' visors. This requires changing out the commerce program for the tactical analysis program.

SCANNER PROBE

The scanner variant of the courier robot scans environments, producing holographic representations for law enforcement agencies, mercenaries, and salvage teams, along with information on energy sources, radiation levels, heat signatures, and identified or alien technology. Requires changing out the magnivision for a C-Thru Analyzer and adding a toxirad gage.

SENTRY

It is an ideal security sentry that can alert the party to movement and raise an alarm within a camp or in a corridor. Simply replace the commerce program with a security grid program. It will then use its holoprojector to display light lines that will trigger the alarm if the light is broken to the robots eye.

SIGNAL JAMMER

By changing out the commerce program for a local signal jamming program, and the bureaucracy program for an interference program, the robot can use its communications ability to jam and garble specific transmissions in the area, including communications, scanners, and robot control signals. This can be effective to preventing the opposition from calling for reinforcements.

SPOTTER

A courierbot can be a sniper's best friend. It can give the sniper distance, wind speed and direction, and identify the window of opportunity to make a sure kill. The sniper's accuracy is increased by 20%. It can even be used to improve the accuracy and range of sentry weapons by 10%. This requires changing out the commerce program for the tactical analysis program.

SUBSPACE BEACON

Just as the courierbot can be programmed as a beacon, if it is gutted and a subspace communicator is added to it, it can act as a subspace beacon as well, to inform of dangerous hazards or wreckage, or to draw authorities to rescue the party. As with the simple beacon, give it a pre-recorded message to repeat at certain intervals and have it activate its homing beacon, playing them over the subspace channel.

PLAYING A COURIERBOT

Playing a courierbot is relatively straight forward. However, there are some notes to consider.

Traits. Courierbots are known for sticking to their master or their assigned target with unswerving tenacity. This can make them a loyal escort or bothersome nuisance. Whatever task they perform, they perform with what could only be described as enthusiasm, even if artificial. This makes them a favorite of military personnel.

Stock courierbots are also quite talkative. They'll talk your ear off if given half the chance. They usually talk about past experiences and individuals they've met. They also talk about similar circumstances they've been in or about the situation itself. They must be specifically requested to stop talking or else have their personality matrix changed out or removed. They can, however, be given specific direction about when to speak or not to speak, but any situation that falls outside of that specific direction is fair game for the robot to start talking.

Body Language. Shaping your hands in a semi-spherical shape approximately 1 foot apart (0.3 m) and moving them as if the eye and readout is between them can show the players what the courierbot is doing and where it's looking as you act out its character.

Speech Pattern. Stock courierbots come with a speech program that includes a very fluent, non-technical way of speaking.

Voice. Courierbots are often a bit smarmy, like an advertiser or announcer. Their voice program has a variable gauge that controls how smarmy and loud the voice is. To change the voice, you must remove or switch out the speech program.

ROBOT EQUIPMENT

By C. J. Williams

BOTLINK

A botlink is a plug and play device (progit) added to a chronocom or other communications device that allows you to communicate with your A.I. with the full functionality of whatever device the progit is plugged into. The A.I. uses the device to which it is linked to assist their master efficiently. An A.I. may be linked to multiple devices simultaneously, using each device remotely. A botlink can be added to any computer, robot, vehicle, or ship that has networking capability to be remotely operated by the A.I. and communicate with whoever is in contact with the botlinked device.

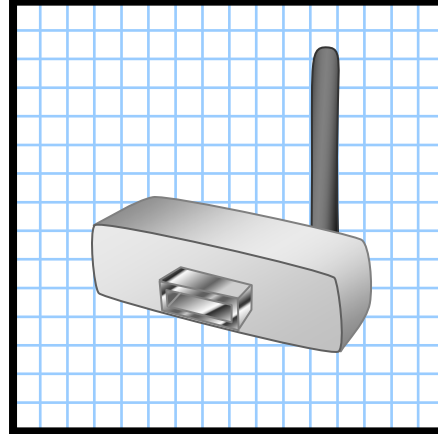

There are many, many opportunities for using this to your advantage. Wherever there is A.I. with a communications uplink, you can connect to it by means of the botlink. The botlink is pre-coded to the A.I. to which you wish to connect, so that all you have to do is plug it into the device and give the A.I. a command. The botlink has a range of 5 kilometers without a communications network, or if connected to a communications network, it's range is that of the network. A botlink does not require the Computer or Robotics skills to use.

» 500 Cr.

BOT RESTRAINER

A cheap alternative to memory wipes is a restraining device. When the robot goes out of range of its master, the device scramble's the robot's systems so that it cannot function. There is a 20% chance that it may pick up a quirk that will last 2d10 days while its programming works itself back out. If that happens, roll once on the *Revised Quirks and Glitches* table in this issue. If you roll "Roll twice on this table", ignore it; the robot does not pick up a quirk.

» 150 Cr.

BOT TRACKER

The bot tracker is a simple global positioning tracker that is attached to a specific robot. It can track the whereabouts of a specific robot within a 5 km radius where no wireless network exists, or anywhere within the range of a wireless network where one exists. This device has no size or program requirements. It can be tracked using a chronocom or other networking device.

» 70 Cr.

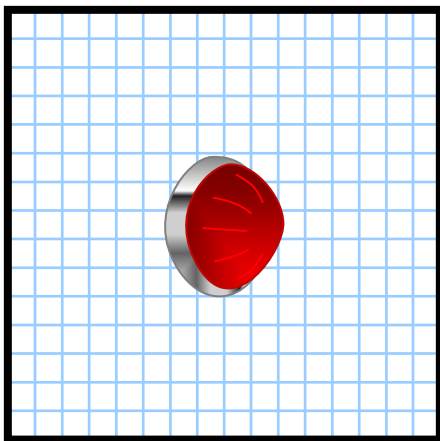

CREDIT SCANNER

If you have ever wondered what is used to read your credit chip, this is it. Add this to a robot to be able to charge credits or verify identities.

» 700 Cr.

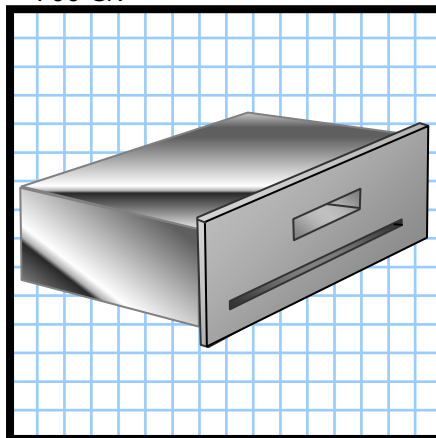

C-THRU ANALYZER

This wonder of the modern age allows the robot to harmlessly see through any item of mild density without x-rays, allowing it to identify any object through clothing or on the other side of organic tissue.

» 1,500 Cr.

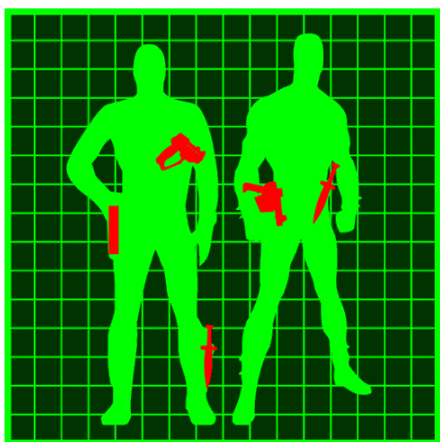

CUTTING TORCH

This arc welding instrument is an internal attachment that sends out an arm with the welder attached to operate in any environment. Requires 2 SEU per turn of operation.

» 500 Cr.

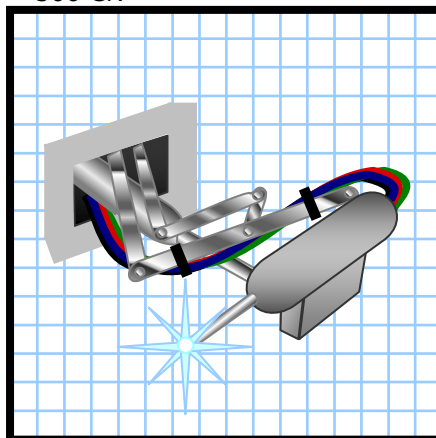

CHARGING DOCK

This device can be added internally or externally to a robot, allowing players to recharge their powerclips and powerpacks in the field. Requires a sufficient power source within the robot or that the robot be plugged into a power source. Charges 5 SEU per hour.

» 400 Cr.

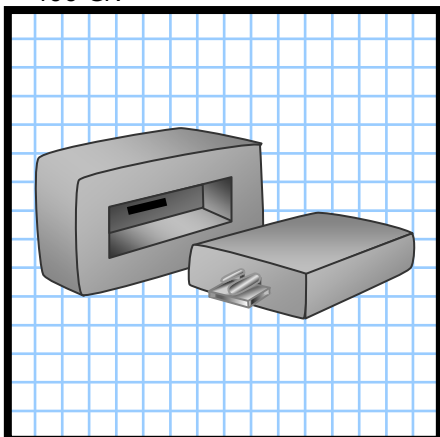

HOLOPROJECTOR I

This is a long bar of molecular fluorescing projection lenses used to project a 2-dimensional image in air.

» 1,000 Cr.

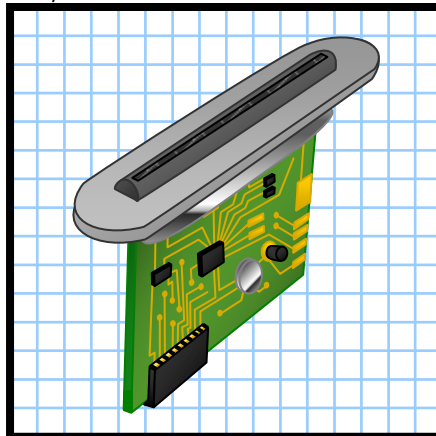

HOLOPROJECTOR II

This is an asterisk-shaped molecular fluorescing projector used to display 3-dimensional images in air.
» 1,500 Cr.

HOLORECORDER I

A single lens that records a 2-dimensional image to be relayed through a holoprojector of any type.
» 700 Cr.

HOLORECORDER II

Three lenses placed 0.02+ m apart in a triangular pattern to record 3-dimensional images to be relayed through a holoprojector of any type. Note that type-I holoprojectors will still only be able to show a 2-dimensional image. 1,200 Cr.

PLASTISCREEN (DISPLAY)

This flatscreen display is made of clear plastic through which a high-resolution image may be viewed for any purpose. 300 Cr. x diagonal length in meters.

WEAPONS DART ATTACHMENT

This small air-propelled weapon mounts to a robot or weapon externally and fires a dose dart projectile.
» 200 Cr.

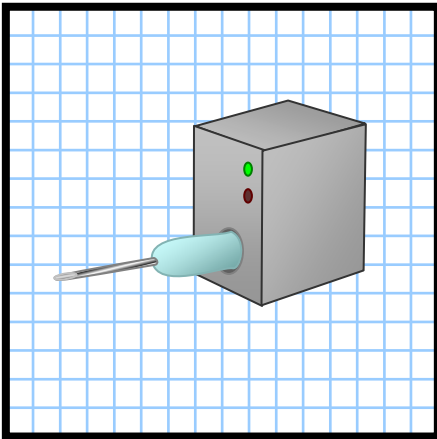

AMMUNITION DOSE DARTS

A supply of 5 dose darts are available for the dose dart attachment or a gyrojet weapon. They can be filled with any light liquid.
» 10 Cr.

PROGRAMS

Facial Recognition Program

Every robot of level 2 or higher is equipped with a facial recognition suite to be able to identify individuals it is familiar with. Can wirelessly access nearby public records if wireless access is available to compare any individual and identify them. Face-changing disguises have a 60% chance minus program level (x10) to fool the program.

» 750 Cr. +50 Cr. for public records access per day.

INTERFERENCE PROGRAM

This invasive program injects itself into a transmitted message and provides interference to the legibility of the message. For encrypted messages, it sounds like static. For unencrypted messages, it sounds like various tones and beeps interspersed with static, remodulation, and flanging, making reception difficult. If used in conjunction with a signal jamming program, it can make clear reception near impossible. Where one fails, the other will likely succeed. If a signal jamming program is successful, there can be no chance of countering the interference program. Requires a single opposed Manipulate Program check to defeat; if it fails, the attempt to defeat the interference cannot be repeated for one hour, and the interference program succeeds.

» 1,000 Cr.

SECURITY GRID PROGRAM

In conjunction with a holoprojector, the security grid program allows a robot to set up a light grid in the immediate vicinity while the robot is in sleep mode to detect any object that breaks the beam.

» 500 Cr.

SIGNAL JAMMING PROGRAM

To intercept and prevent a signal, you need a signal jamming program. This program disrupts the ability of a signal to transmit successfully. It uses a modulating signal to override and confuse receivers from receiving a clear signal, causing the message to drop in and out. This will also disrupt robot control program signals. Robots whose signals are interrupted will behave according to their normal programming or stop moving. If used in conjunction with an interference program, it can make clear reception near impossible. Where one fails, the other will likely succeed. Requires a single opposed Manipulate Program check to defeat; if it fails, the attempt to defeat the jamming cannot be repeated for one hour, and the signal jamming program succeeds.

» 1,000 Cr.

»

SIGNAL OPTIMIZER PROGRAM

This program boosts the signal, weeds out corrupted data, and replaces it with approximated information to fill the gaps. The result is 76% increased clarity. So whatever the chance of success at receiving a signal, multiply it by 1.76, and round down to achieve the new success rate. Does not work against signal jamming programs.

» 500 Cr.

TACTICAL ANALYSIS PROGRAM

This program allows a robot to analyze its surroundings and make tactical judgments as if a normal PC, but with enhanced data increasing accuracy by 10% to all linked individuals and estimating the position of hidden targets with +20% effectiveness. Requires visual and audio receptors. Can be used to transmit field data to HUD displays in the field with a botlink.

» 1,000 Cr.

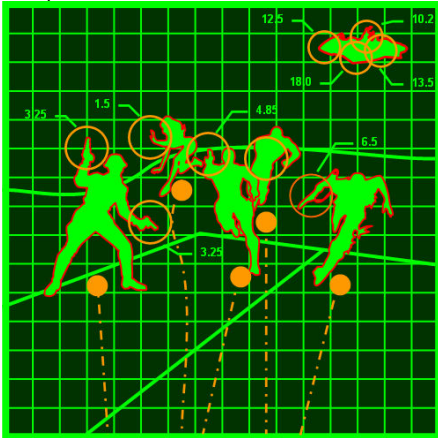

TRANSLATOR PROGRAM

Translates any known language in the Frontier. Requires an audio receiver and a poly-vox.

» 1,000 Cr.

TRANSMISSION ANALYSIS PROGRAM

This program is designed to key in on key words or voice patterns in unencrypted messages, then determine the nature of the message and pass on any suspicious messages to its controller.

» 1,000 Cr.

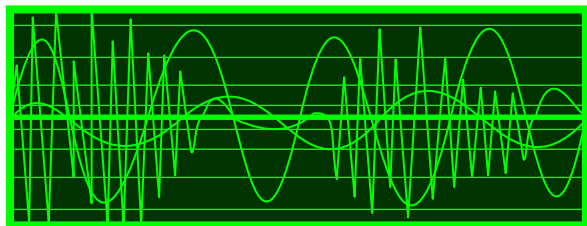

VOICE SIMULATOR PROGRAM

Analyzes and recreates a voice print. Requires an audio receiver and a poly-vox.

» 500 Cr.



Cloud Flyer

The cloud flyer is an atmosphere craft specially designed for use in hostile environments. It has a completely pressure-sealed cabin and cargo area; protecting the occupants and equipment from hazardous or toxic environments. The cloud flyers main wings are swept back reducing wave drag and giving it a predator type appearance. The shorter forward wings, mounted near the nose, rotate allowing the craft to tightly maneuver over rough terrain while traveling nap-of-earth.

Cloud Flyer (Civilian jet plane)

Cost: 40,000 Cr

(Rental 200CR down, plus 100CR/day)

Size 4, jet vehicle

Top 400, **Cruise** 150, **Accel** 100, **Decel** 50

Pass 6, **SP** 650, **Cargo** 3,000kg, 3 m³

Aero-Flyer (Military jet plane)

Cost: 76,550 Cr

(No rental available)

Size 4, jet vehicle

Protection 6, **Hardpoints** 12 (4 remain)

Top 500, **Cruise** 250, **Accel** 150, **Decel** 75

Pass 6, **SP** 650, **Cargo** 3,000kg, 3 m³

Large surface mount x2

» Large laser cannon x2, Range: 1000, Usage: 60, Damage: 6d10x10, Skill: Beam

Original concept by **David "Zeb" Cook**; Aero-Flyer modifications using the non-civilian duty vehicle upgrade from #15-p26

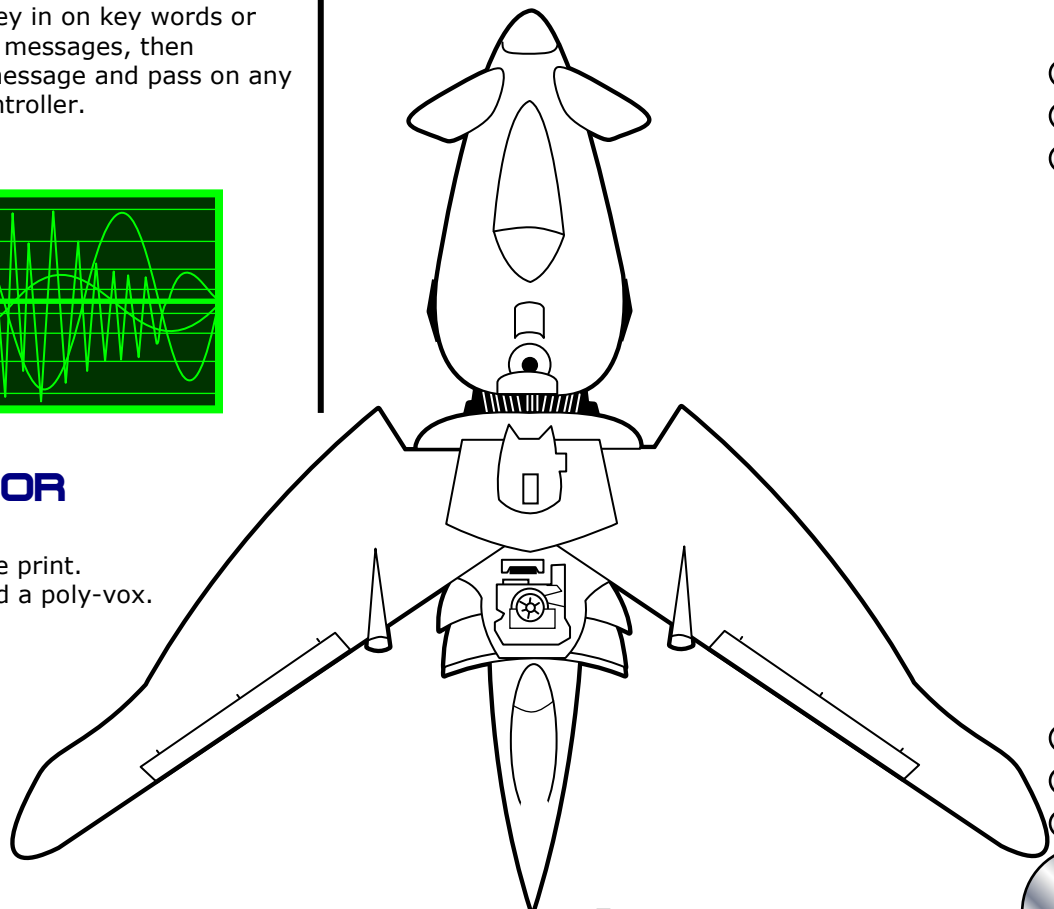

DISEASES IN THE FRONTIER

By Eli Arndt

Editor's Note: Eli and I used Google Docs, a great resource to collaborate on articles, to craft a list of diseases for Referee's to throw at characters. Eli has an awesome blog over at "I see Lead People". Check it out! <http://leadpeople.blogspot.com/>



NATURAL DISEASES

Ferrosklerosis (Iron leg)

This disease is contracted from tainted water. After 2d10 minutes the victim's joints slowly stiffen, then after 1d10 hours movement of any kind, even speech, is impossible. There is no know cure except to drink clean water to 'push' out the disease. Referee's option on how long it takes to recover.

Acute Vermiform Masticular Nervosa (Ick)

Contracted from a rodents bite, this disease makes the victim feel icky causing his muscles to relax and his thoughts to wander. After 2d10 minutes the victim takes -10 to all actions. The disease can only be cured by a modern hospital and cost 300 credits and 1d10 days to recover. The medical prescription is included in cost. The character must take the prescription for 2 weeks 3 times per day with food.

Chronic Cellular Ossification (Petro Virus)

A disease that only affects dralasites and other amorphous plants/creatures. Over time the disease replaces dralasite flesh and organs with crystals causing calcification. The process is extremely painful. In plants the disease works the same way. Trees are usually affected from the inside and become apparent when the tree suddenly falls after breaking at the calcified region. In order to remedy this disease the calcification must be removed from the body.

Although the dralasite will loose mass equal to the removed crystals, dralasite medical technology is the best in the Frontier. A simple tissue (or organ) sample is taken from the patient and replacement tissue (or organ) is grown in the lab. It takes 2d10 weeks before the replacement is ready to be acclimated to the patient; it's carefully stitched and soon merges (2d10 days) with the host.

Chronic Premature Degenerative Ecdysis (Soft shell)

This disease causes a vrusk to begin molting, each time its carapace is re-grown the material becomes weaker and weaker. The carapace will re-grow 1d10 times, each time the vrusk will loose 5 stamina permanently. It takes 2d10 days before the molting process begins and another 2d10 days before the next stage.

Viral Manic Hyperphageic Dementia (Zombie Virus)

The victim is not aware he is infected, not even when the disease takes full effect. After 2d10 days the victim starts loosing -10 to all action and skill checks. Each day he will loose -10 until his chance of success is 0. At this time he becomes lethargic and zombie-like. His only concern is to feed himself. He will search for food such as mold, grass, bark, garbage, and carcass; anything that is slow enough for him to catch. There is no known cure when someone reaches 0.

Patagic Eczema (Scab Wing)

This Yazirian affliction manifests as a crusting and, in severe cases, scabbing of the wing membranes. This condition usually begins at the armpits and spreads out from there, covering more and more of the wing surface in thick, cracking crusts of dead skin. It causes intense irritation and eventually a weakening of the wing membrane. In severe cases, the tissue deterioration can cause bleeding and lead to tearing of the wing membrane. At first this is nothing more than an irritation but as the scabbing increases there is a chance the wing will separate or rip. The chance is equal to 10% of the characters current stamina and increases 5% for each week untreated. Natural treatments take 2d10 days to cure scab wing and are only found on yazirian worlds. After 2d10 hours the yazirian will notice immediate improvements. Anit-Scab pills can only be purchased with a prescription on most civilized worlds for 75 credits. Over the counter remedies include Gelapo (2 credits per 30ml) that do not heal scab wing but relive some of the symptoms. Some doctors attribute the cause to "Yazirian Power" a common deodorant found throughout yazirian space.

Dralasite Pore Mites

This non-viral affliction takes the form of small microscopic mites taking up residence in the pores found across a dralasis skin. Initially nothing but a nuisance, unchecked infestations will lead to a reduction the dralasis ability to gather breathable gases from the atmosphere. Early onset infestation is undetectable with the naked eye but does cause minor irritation in the host. As the infestation grows an inflammation of the pores will become evident giving the dralasis a pock-marked appearance.

Yazirian Mange

Yazirian Mange is a bit of a misnomer as it is not related to any sort of mite or other infestation. The name is derived from the haphazard appearance of the hair loss experienced by the afflicted. Unlike human male patterned baldness the mange effects all body hair. Yazirian's often loose their hair in clumps causing unsightly patches throughout their mane. The only known cure is a series of intense (and often painful) chemical injection treatments to the epidermis. Once the progression of the mange has been halted, there is no guarantee that the lost hair will grow back. Some yazirian's undergo follicle treatment removing hair from areas of their body and integrating on bare spots. Synthetic hair is available in an assortment of colors, each 10cm area cost 550 credits and is typically not covered under medical insurances. Natural hair can be integrated as well but most yazirian's will only accept hair from a clan member and color matching become a problem.

Chitin Barnacles

Vrusk bodies cover a lot of space and these little organisms are more than happy to take advantage of the flat living surface provided by the linear forms of these and other insectoids. In their larval state, chitin barnacles take the form of nearly microscopic polyps floating on wind currents. When they encounter an insectoid species they fasten themselves to their exoskeletons using a naturally secreted resin. Once in place, the barnacles begin to sink their fibrous roots into the chitin, anchoring themselves in place. These fibers burrow through the chitin and into the tissue beneath, drawing nutrients from the host's body. Over time the parasites will build up knobby shells of resin and calcium, protecting them further and making them more difficult to remove from their host. Once a vrusk is infected he tends to eat more at the dinner table to compensate for the extra "mouths" to feed.

Fungi Flesh

Dralasites that prefer to live in steam dormitories have a tendency to develop a mildew residue all over their bodies. Not really life threatening the mildew has a very strong odor that is disagreeable with most species. Those within 2m must make a stamina check or become ill for 1d10 turns. A day in the sun and a cold shower with a good scrubber will rid the dralasis of this annoying and socially distasteful infection quickly.

Anti-Rage

This virus affects the part of the yazirian brain and synaptic response that allows him to become enraged. No matter what he does he can not enter into battle rage. Scientist are stumped as to the cause, eventually the virus clears the system.

Retinitis pigmentosa (Night Blindness)

This degenerative disease affects all four core races. However special attention is given to yazirians. This disease reverses their natural ability to see in the dark. Eventually their sight becomes accustomed to daylight which ignores the -15 penalty to RS and DEX.

ENGINEERED ILLNESSES**Sathar Genetic Regression Virus**

First seen during the First Sathar War, this horrible virus was only ever unleashed in a limited way. Since then, very few cases have been confirmed but it is known to still exist and is thought to have found a safe harbor in some population in one corner of the Frontier or another. The virus manifests by triggering renewed tissue and bone growth but at the same time activating, rather haphazardly, dormant genetic traits from the infected species. The result is massive mutation accompanied by intense pain, agony and a rush of hormones that induces serious chemical instability in the brain. The resulting overload induces a psychotic rage in the victim, causing the newly created mutant to become uncontrollably hostile to those around it.

An infected being will rage, attacking other beings, robots, creatures, household pets even Coke machines. The rage will continue for a number of hours equal to the characters current stamina divided by 10. For example; a character with 50 stamina will rage for 5 hours non-stop. After this time they will become exhausted, sleep quickly overtakes them. They may sleep for 12 hours or more. There is no known cure. Victims are typically frozen (or use a freeze-field) at a local hospital then transported to Star Law for storage until a cure is found.

Gilliam's Plague

Human scientist Dr. Jera Gilliam is the man responsible for this debilitating virus. Originally an attempt to create a universal anti-virus, the result of Dr. Gilliam's work was an incredibly viral strain that attacks the immune system of its victims. Characters are more susceptible to colds and flu's. At the Referee's option infected characters may have reduced success for skill checks (due to lack of concentration) - sneezing when trying to stealth, vomiting after eating, sniffing during an interview or any number of other effects that might disrupt an otherwise successful skill check.

DralPox

This is a vicious biological weapon of unknown origins that has been encountered rarely but memorably throughout the Frontier. An engineered virus, DralPox only effects dralasite physiology. DralPox manifests by breaking down the fluid structure of the various components of a dralasite's body. Initially this impacts the dralasite's ability to retain shapes but over time it will begin to impact his health affecting everything from respiration to digestion. If left untreated, DralPox will eventually cripple and even kill the victim as they lose most or all of their ability to maintain fluid integrity. As the disease progresses, leaking lesions appear on the outside dermal layer of the dralasite, giving the disease its common name.

OTHER CHALLENGES**Conductive sand**

Sand that contains microscopic conductive metal particles causing shorts in electrical equipment. This sand can cover an entire desert or portions of the desert depending on the needs of the Referee. Exposure is limited to the amount of sand that is blown into the air.

- » No wind; after 2d10 hours the chance of short is 10%. This percentable increases 10% each hour thereafter.
- » Breeze; after 1d10 hours the chance of short is 30%. This percentable 10% each hour thereafter.
- » Gust: 2d10 minutes the chance of short is 50%. This percentable 10% each hour thereafter.

Note: Sand can be substituted with mold, water vapor or other air borne forms.

**JUST HOW MANY WEAPONS CAN I ADD TO MY SHIP?**

By Thomas Verreault/jedion357

The rules in Knight Hawks concerning modifying civilian ships are written in such a way that first you decide all the weapon and defenses you want then compute your ADF & MR. It's a bit awkward if you tried to add too much and now have to figure out how much and what should be cut. Wouldn't a system where you decide what the ADF & MR will be and compute how much you can add in weapons be nice?

That, fellow Frontiersmen, is here: $x(1+y) = z$

X is the value of half the hull size of the ship in question. Y is the total number of MR and ADF point you are willing to remove from your ship. Z is the total number of MHS in weapons and defenses that you can add.

Say you had a hull size 12 freighter with atomic engines and a base ADF and MR of 3 each and you decide to sacrifice 1 MR for some weapons? How many weapons could you add? Plug in x & y; $6(1+1) = 12$ MHS of weapons and defenses before you'd have to spend an ADF point.

Suppose you just came into possession of a hull size 6 ship with ion drives and figured that since its ADF and MR are already 1 each because of the drive system you might as well max out its weapons. A hull size 6 ship has a base ADF & MR of 3 each so you can use 2 points from each for a total of 4 for the value of y: $3(1+4)=15$ MHS of weapons and defenses.

Remember that each point loss of ADF and MR reduces cargo carrying capacity. This is actually has less impact on a bigger ship than a smaller one. In the example of a hull size 6 ship being maxed out on weapons and defense, because it used 4 total points from ADF and MR it now is the equivalent of a HS 2 freighter! Whereas blowing off 4 points from a hull size 12 freighter only reduces it to a HS 8 freighter in carrying capacity.

This formula is actually easier to use than the one in the rules and it tells you exactly how much you can modify a ship.



TASKS OF THE SKILLED FRONTIER

By Thomas Verreault
jedion357

Author's note: This article was inspired by the SF 2000 rule set and Bill Logan's article "A Skilled Frontier" in Star Frontiersman #9 and is designed to work with those systems of character creation.

The trend in updated rule systems for the Star Frontiers game has been toward using half the appropriate ability score plus 10% per skill level to compute scores needed for success. While it's simpler and cleaner it doesn't mesh well with the original game tasks covered by the sub-skills. Under most of the newer systems all medical skill rolls are computed on one half the LOG score and 10% per skill level. This means that first aid and all levels of surgery carry the same chance of success. Also in areas like computers, *by-passing security* and *defeating security* are also the same level of difficulty.

I had kicked around an idea to figure out the relative difficulties of all the Alpha Dawn sub skills and chart a table of modifiers. Such a system would have the benefit of exactly following the original rules but would have a large cumbersome table too difficult to use easily. So I'd like to propose a simpler system of rating task difficulty.

All tasks will fall into four categories and any new task can be ruled on by the referee and have the appropriate task modifier added. The categories are Trivial, Easy, Average, and Hard.

Trivial Tasks

These tasks are listed in Alpha Dawn sub skills system and have a chance of success equal to 100%. They are also any task that the referee rules should automatically succeed. The task modifier is +70%.

Most times it shouldn't even be necessary to roll for success as the average ability score is 50 and with only one level of skill a character would have a modified 105% chance to succeed. If a task is trivial and there are no negative modifiers involved rule it as an automatic success and forego dice rolling. The occasions when a roll is required would be doing first aid (a trivial task) on an alien (non core four races) as that carries a -20% modifier. Even if a level six medic was doing first aid on an alien he should still roll despite having an average chance of 135% or more to succeed despite the alien physiology modifier as a roll of 98-100% is an automatic fail. The basic rule to decide if a trivial task should be rolled for would be if there was any sort of negative modifier involved and no matter what the final chance to succeed is a roll of

98-100% is still an automatic fail. The modifier for a computer or robot's level counts as a negative modifier.

Easy Tasks

These tasks are modified by +30%. These types of tasks should succeed most of the time by a character with level 1 skill. These tasks must be rolled for every time.

Average Tasks

Modified as +15%, these are tasks that should be succeeded at on average 50% of the time by a character with level 1 skill. These tasks must be rolled for every time.

Hard Tasks

These tasks carry no modifier, therefore use +0%. These are tasks that should succeed at less than 50% of the time by a character with level 1 skill. These tasks must be rolled for every time.

Optionally, a referee may grade a particular task as more difficult than normal but instead of increasing the level of difficulty require the player to roll twice to get a successful completion of the task. For example a character is performing major surgery and passes his first roll so the referee announces that the surgery is going well but there is sudden bleeding that must be gotten under control requiring a second roll. If a character passes the first roll but not the second the referee can rule a total fail or half success. Other examples could be flying an air car in hurricane conditions or repairing a robot while under fire in combat.

Some of the tasks in a category below were slightly more difficult in the Alpha Dawn rules than the other tasks of their category. To indicate this I placed a +1 after tasks that should be slightly harder than others. A referee could ignore this or increase the difficulty by -5% or require two rolls as he see fit though he should be consistent in how he does this.

Concerning star ship skills from Knight Hawks, some are actions taken in the same manner as Alpha Dawn skills and these are in the list below. Others, however, simply add modifiers to other rolls in the game. For example the engineer's skill can modify the roll made to see if a ship will break up or the piloting sub skill that increases the accuracy of forward fire weapons. For skill use that is actually a modifier of other skill rolls, no change is necessary. The one exception is risk jumping and it seems that the best thing to do with this sub skill is leave the Knight Hawks rule as is.

Note, the task difficulties were chosen by a rough scale of the Alpha Dawn rules. However, judgment calls were made on things like setting and defusing demolitions charges that it should not be harder to set a charge then to defuse it as a key component of being able to defuse a demolitions charge would be knowing how they are set. Also the task modifiers are calculated to produce results of better than average, average and less than average for a level one character. Obviously higher level characters will benefit and succeed more from these modifiers but then being higher level should have its perks.

Trivial Tasks +70%

Computer skills:

Operate a computer program

Environment skills:

Making tools in a survival situation

Naming new discoveries

Knight Hawks skills:

Plot interstellar jumps

Ship design

Medical skills:

Administering drugs

First aid

Robotic skills:

Activate/ deactivate a robot

Add equipment to a robot

Identify robot

List a robots functions +1

Easy Tasks +30%

Computer skills:

Defeat security

Display information

Manipulate Program

Repair Computer +1

Environmental skills:

Analyze Samples

Find Directions

Survival

Knight Hawks skills:

Increase maneuverability rating

Medical skills:

Control infection

Cure disease

Diagnosis

Minor Surgery

Robotics skills:

Alter functions

Altar mission +1

Remove security lock

Repair robot +1

Technician skills:

Deactivate alarms/ defenses +1

Detect alarms/ defenses

Open locks

Operate machinery

Repair machinery +1

Average Tasks +15%

Computer skills:

By pass security

Interface computers

Environmental skills:

Analyze ecosystems

Tracking

Knight Hawks skills:

Find Location

Medical skills:

Activate a freeze field +1

Neutralize Toxin +1

Military skills:

Defuse or set a demolitions charge

Phycosocial skills:

Communication

Physco Pathology +1

Hard Tasks +0%

Environmental skills:

Concealment +1

Stealth

Medical skills:

Major Surgery

Military skills:

Using a weapon

Martial Arts

Phycosocial skills:

Empathy +1

Hypnosis

Persuasion +1

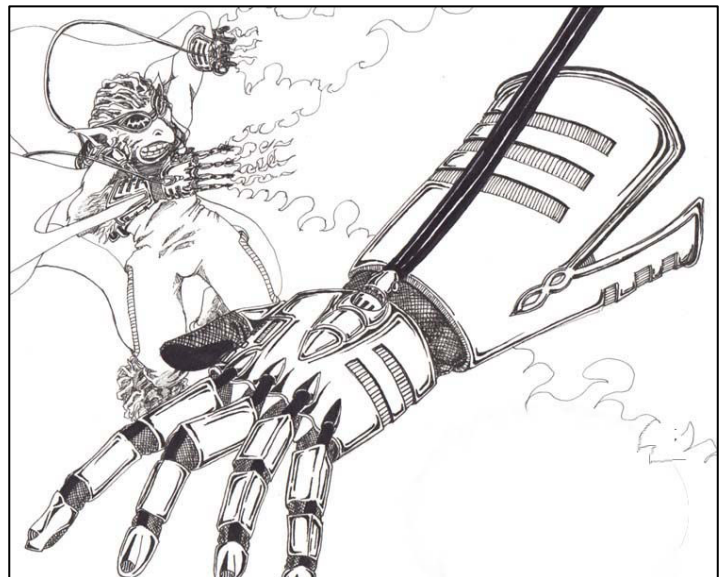

Yazirian designed flame thrower gauntlets.
Flaming death from above!

THE VILLANOUS NPC MASTER PLAN

By Larry Moore

Have you ever wanted to create a villain NPC that starts about the same time as the player characters? As the characters progress and grow in prestige so does the villain. The PCs may not be aware as the villain runs into and around the player's adventure areas.

The following steps are guidelines to start the nefarious NPC's career. The running example uses one of my favorite NPCs, the Malthar from the Star Frontiers module Dramune Run.

STEP 1

Seek a way to control others

The villainous NPC may start his career with cohorts who are of the same mind; however, he will ultimately be the one that comes out ahead. He may eliminate the others or have a means to control them until their usefulness expires. Charm, greed, fear, technical knowledge is some of the ways he can exert control over individuals.

Before the Malthar was, "The Malthar" he was a shuttle pilot ferrying cargo between Majora and Pinnacle stations in the Dramune system. He often made shady deals with spacers in bars and seedy areas making extra runs off course. He introduced several other dralasites to the lucrative but illicit trade.

Encounters: The PCs might meet this villain in a public area while passing through Dramune or possibly catch a ride ferrying between ships or stations. If the PCs frequently run into this villain they develop a relationship with him; he is the best bush shuttle pilot this side of Majora and his prices are right even if he is

a slob. He always has food on the piloting controls, pop cans litter the floor, and your eyes are always drawn to food caked in his webbed clothing.

STEP 2

Obtain personal power by gathering followers

This NPC hangs out in slums, bars and the shady areas of civilization seeking those that need the benefits he has to offer. He exchanges these "benefits" for muscle, information or credits. Thugs and goons are drawn to the villainous NPC, they are able to keep a low profile while in his company, after all there is safety in numbers and it beats getting a job.

Quickly the Malthar's network of friends, associates and favors grew. He is known throughout the underground as an up and coming crime boss, at least to his followers.

Encounters: When the PCs come looking for a shuttle flight they're met with stern stares and pointed questions, "What do ya want with Malthar?" He'll give them a shuttle hop but in exchange for a favor or two.

STEP 3

Establish a base of operations

Now that the NPC has a following he can control he'll seek a place to run his business by establishing a base of operations to work from. It could take the form of a hidden room inside a large abandoned warehouse, a storefront, or within an established corporation. Other areas include; religious complexes, abandon mining camps, or a spaceship.

The Malthar has grown large enough that credits and information filters in from his followers, he is no longer required to pilot shuttles to make contacts. He decides to establish a small office in an abandoned area on Darkworld station; it offers anonymity, access to the spacer information lanes, and is tucked away from other crimes organizations prying eyes. He hires a group of technicians to seal this area from the rest of the station's life support systems and builds a makeshift docking collar for his personal escape craft. The techs are never seen again.

Encounters: If the PCs travel through Dramune or are looking for their favorite shuttle pilot they hear a rumor that the Malthar has moved his shipping business to Darkworld Station.

STEP 4

Make connections and start new operations

The NPC exchanges favors, credits, or other goods and services to make connections outside his area of



control. This spreads his influence into areas he may not be accustomed with.

The Malthar branches out into the drug trade hiring and bribing scientists away from SynthCorp who specialize in pharmaceuticals and designer drugs.

Encounters: SynthCorp hires the PCs to track down a former employee who stole company property (a drug formula) and recover it for them. The PCs track the scientist to a lab on Outer Reach and discover that he is working for the Malthar. The PCs report their findings to their employer; undoubtedly the Malthar will not be pleased with this news once it reaches his information sources.

STEP 5

Control

The NPC has followers, a base of operations and has branched into other areas of business. He aspires to gain control over a large area to expand his operations. His purposes might require controlling a town, city, corporation, cult, cadre, religious establishment or government. This control is absolute; what he says is law, there is little or no opposition to this authority. His method of control may take the form of a dictator or the use of subtleness to excerpt this authority over the controlled area.

The Malthar gains total control of Darkworld station through the drug trade he sponsors. His authority is absolute. His personal protection is his biggest concern; thugs and goons are replaced by the finest combat robots available. His influence has branched into the pirate hordes in the Dramune system, although not under the control of the Malthar, they find it's in their best interest to do his wishes and usually it's profitable.

Encounters: The PCs, who still work for SynthCorp, hear rumors through the company grape-vine that executives are becoming concerned with the spike in designer drugs emerging from the Dramune system, These drugs violate several company patents. The PCs are sent to recover samples of drugs from the illegal trade in Dramune for analysis in company labs.

STEP 6

Form an external security force

In Step 5 it's assumed the NPC has a security force to control his local area. This particular security force is used outside his area of influence to accomplish various nefarious tasks. The force may be highly trained commanders who have low-level followers although a single small force may be all high-level commandos. One such force will most likely have access to the best gear, vehicles and smaller spaceships.

The Malthar cut a deal with pirate bands in the Dramune system, giving them a safe haven aboard Darkworld station and employing them as external muscle in system and outside of Dramune.

Encounters: While the PCs are trying to ex-filtrate from Dramune with their drug samples a pirate band attacks their star liner. They begin to discover the extent of Malthar's power. The pirates are not after the PCs per se but they must protect their "package" and get back to SynthCorp headquarters.

STEP 7

Remove rivals

The NPC uses his connections and security force to further removal rivals within his domain and expand his controlled area. He may even call in a favor from Step 4 to have someone eliminated in someone else's domain.

The Malthar learning that SynthCorp is on to his schemes dispatches a small team of mercenaries to raid the SynthCorp corporate office and kill the executive that the PCs report too.

Encounters: The PCs are present during the raid and must flee to survive. In the aftermath they are let go from SynthCorp as a new executive comes in and cleans house to install his own people.

STEP 8

The ambitious may never stop

At this point the NPC has vast resources, influence and a mobile military force. He may desire (or already be involved in) Frontier-wide politics and plan on taking over the Frontier (or a sector of it). He will continue to spread his influence, amass military might, expand his area and place informants in political positions.

The Malthar seeks to target the Frontier at large introducing the most powerful drug known, Ixiol.

Encounters: The out of work PCs are contacted by a desperate star ship captain looking for a crew, Garlus Tylapper of the Gullwind. If they take the job they will be on a collision course with the Malthar. Can they make the Dramune Run?



The Malthar

FINAL NOTES

Survival

A good villainous NPC always has a path to escape. He spends a great deal of time planning his exit strategy - whether his master plan is successful or is foiled by meddling heroic characters. A good villainous NPC returns in a later adventure. The NPC villain might always seek to obtain items which enhance his ability to get away quickly, or surround himself with thugs to handle the meddling heroes so he can secure his exit. For example, the NPC villain might plot his nefarious schemes in locations which have cliff faces nearby, and he might have an air car driven by a trusted minion ready to swoop by and catch him when he leaps off with his concealed parachute.

Death

Keep in mind that villains should always be defeated by the characters at some point during a campaign.

We Got Him!

The most memorable experiences my players have had is a reoccurring villain they eventually defeated or outsmarted. They tend to remember them more than the reason they were adventuring.

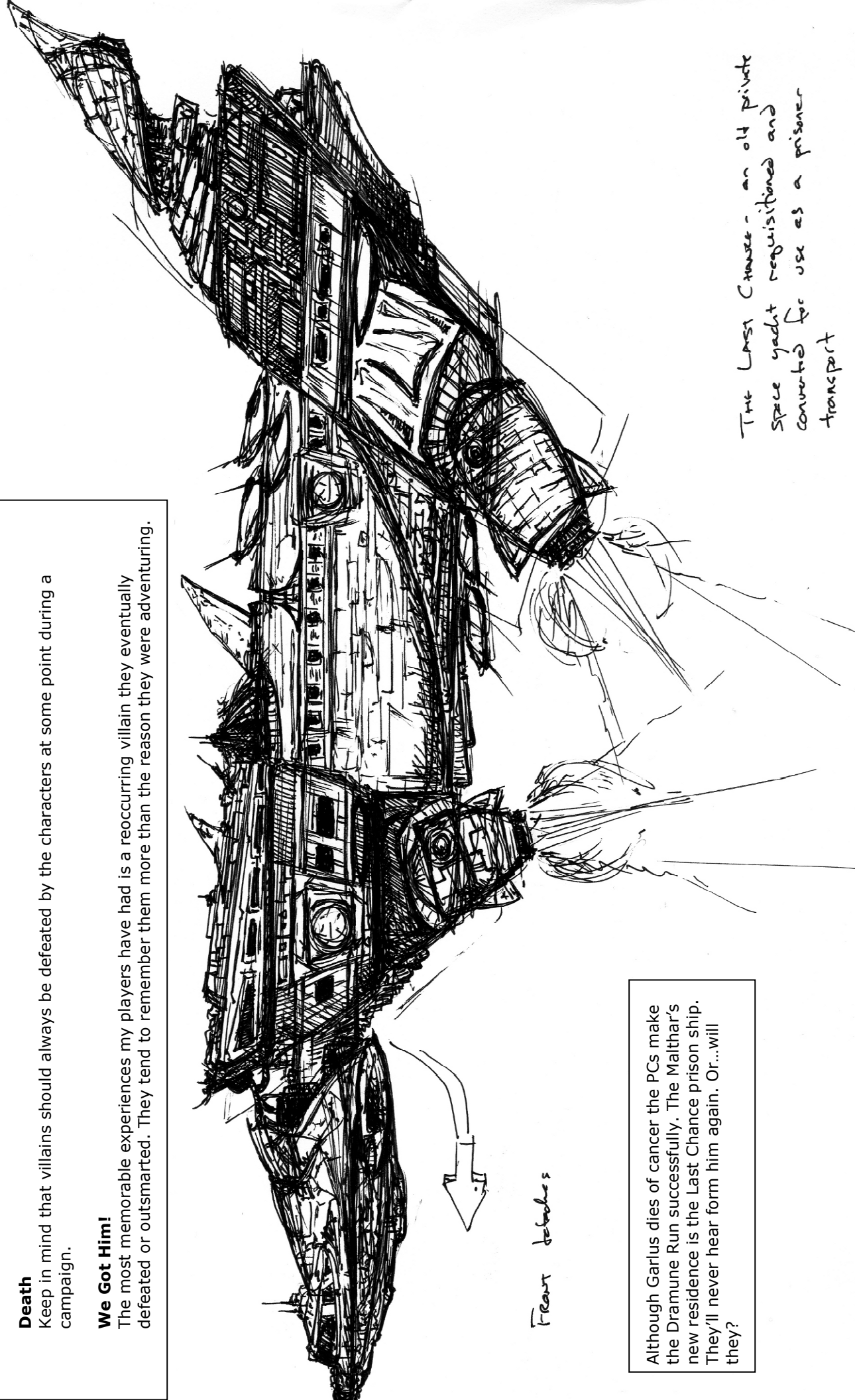

Fearful features

Although Garlus dies of cancer the PCs make the Dramune Run successfully. The Malthar's new residence is the Last Chance prison ship. They'll never hear from him again. Or...will they?

The Last Chance - an old private space yacht requisitioned and converted for use as a prisoner transport

PSA SKILL SYSTEM

Dominic (Nick)
Pelletier

After reading the alternative skill system presented by Bill Logan in Issue 9, I found many things that I liked about this new system. It addressed many of the shortfalls of Alpha Dawn. But at the same time, I preferred the feel of the original Alpha Dawn PSA system. So I took it upon myself to blend the two systems. The intent was to retain the original flavor of Alpha Dawn skill system but utilize the ideas from Bill's article to fix the short comings. What I present now is;

(YET ANOTHER) ALTERNATE ALPHA DAWN SKILL SYSTEM

INTRODUCING PSA CATEGORIES

Borrowing from Star Frontiersman articles and reorganizing Alpha Dawn's original 3 PSA's into "PSA Skill categories" I present you with 6 PSA Categories:

Biosocial

Environmental Skill
Medical Skill
Psycho-Social Skill

Espionage

Social Spy
Spy Craft
Spy Gadget

Intellectual

Artisan
Linguist
Scholar

Mentalist

Metabolic Control
Psychokinesis
Telepath

Military

Demolitions
Martial Arts
Weapon Skills

Technological

Computer Skill
Pilot
Robotics Skill
Technician Skill

Uncategorized

Animal Trainer
Others (cannot be selected as a group)

When picking a PSA for characters, each character has 4 Points to select a skill from within each category; Primary (PSA), Secondary (SSA) or Tertiary (TSA).

Each PSA costs 2 points. Each SSA costs 1 point. TSA's are free. This allows for a maximum of 2 PSA skill

areas while all other categories will be Tertiary -- or up to 4 SSA, with all others being Tertiary. Depending on what skills are selected, will affect the Experience Point (XP) costs for that set of skills as well as others within that category.

Experience point costs mirror Bill Logan's excellent article as the following Table shows:

Skill Level	Primary ¹ PSA	Secondary ² SSA	Tertiary ³ TSA
Level 1	3 (4)	4 (5)	8
Level 2	6 (7)	8 (9)	16
Level 3	9 (10)	12 (13)	24
Level 4	12 (13)	16 (17)	32
Level 5	15 (16)	20 (21)	40
Level 6	18 (19)	24 (25)	48

The Experience Point costs of the chosen skills are per the table above. For any other skill of the same category, the Experience Point cost is an additional 1 XP representing knowledge outside of a chosen specialty but in a related field.

Example: Guluck, a Yazirian, chooses Robotics Skill (Technological category) for his PSA, Environmental Skill (Biosocial category) and Linguist (Intellectual category) for SSA. Each of these skills starts at 1st level. After a few adventures Guluck realizes that he really needs to be able to operate computers and at least some level of medical skill. Computer skill is the same category as his PSA (Robotics) so it will cost him 4 XP to get 1st level (PSA +1). Medical is the same category as his SSA (Biosocial) so 1st level costs him 5 XP (SSA+1). Fortunately, Guluck received 10 XP the last adventure so he is able to get both at first level leaving 1 XP left.

BONUS EXPERIENCE POINTS

Furthermore, a starting character gets bonus XP based on their LOG score to further personalize their character equal to LOG/10 rounded up.

Bonus XP from LOG			
LOG	XP	LOG	XP
1-10	1	41-50	5
11-20	2	51-60	6
21-30	3	61-70	7
31-40	4	71-80	8

These bonus XP's can be used to increase skill levels of PSA's or SSA's, raise ability scores (see below) or racial abilities as per normal rules. Or, they can be used to purchase individual sub-skills that represent knowledge gathered over time or hobbies.

INDIVIDUAL SUB-SKILLS

Sub-Skills purchased individually can never be increased past 1st level.

Single Sub-Skill Cost Table

	Specific Weapon	Secondary	Tertiary	Piloting
Level 0	-	1	2	1
Level 1	2	2	3	2

Level 0 allows the character to attempt that specific sub-skill but with no modifier for skill level.

Example: Guluck chooses Activate Freeze Field as a sub skill at 0 level. Because Medical skill is a Biosocial category, which matches Gulucks SSA, this costs him 1 XP. This allows Guluck to attempt to activate a Freeze field with a base 30% chance. For another 2 XP, he can raise this to level 1, giving him a 40% chance. If Guluck ever wants to increase his ability to use Freeze Fields, he will need to take the Medical Skill.

Important! It is recommended that Mentalist sub-skills NOT be allowed to be purchased individually or after character creation. Final say, however, is up to the Referee.

Optional Rule: To avoid any wasted XP spent on an individual sub-skill, the referee may allow an extra +5% bonus to any sub-skill that was purchased at 1st level and was later purchased as part of a Skill. The Referee may also allow a player to purchase this extra +5% for sub-skills to characters that already have the skill area using the Secondary costs (for PSA and SSA) or Tertiary cost.

Specific Weapon: Can only be purchased at 1st level. Allows +10% to hit with a very specific weapon instead of a category of weapons (gyrojet pistol, or shock gloves, for example). Will provide an extra +5% to hit if the character ends up with skill in the same category of weapons.

Secondary: XP cost to purchase any individual sub-skill from ANY skill in the same category as the character's SSA.

Tertiary: XP cost to purchase any individual sub-skill from any skill category that is not the characters PSA or SSA

Piloting: XP cost to get driving skill in a specific type of vehicle. Note: more advanced vehicles may require additional XP as shown on the table below.

Pilot Vehicle Types

Simple Vehicles	Other Craft	Advanced
Ground Cycle	Glijet	Aircar**
Hover Cycle	Jetcopter*	Cloudflyer**
Ground Car	Small Boats	Submarine
Hover Car	Large Boats*	Runabout* ¹
Ground Transport		Skipflyer* ¹
Hover Transport		Shuttle**
Explorer		Airship

¹ Atmospheric Only

* req +1 XP to learn

** req +2 XP to learn

As per the standard Alpha Dawn rules, *Operate Machinery* sub-skill Level 1 can attempt any "Simple Vehicle". Level 2 can attempt any "Other Craft" Vehicle. Level 4 can attempt any "Advanced Vehicle".

ABILITY SCORE IMPROVEMENTS

Bill Logan's article also highlights another short-coming of the original Alpha Dawn rules: Improving Ability scores. Bill provides an alternate method which works amazingly yet requires a player to not only track the current ability score but also the original ability score. I've provided an alternate ability score cost table that is simpler yet still 'fixes' the issue with the original rules. Either cost system will work equally well with this skill system.

Current Score	Ability Score XP Improvement			
	STR/STA	DEX/RS	INT/LOG	LDR/PER
1-40	½ XP	1 XP	2 XP	1 XP
40-60	1 XP	1 XP	2 XP	2 XP
60-80	2 XP	2 XP	3 XP	3 XP
80-99	2 XP	3 XP	4 XP	4 XP

* Using Bonus XP to raise a LOG score will NOT result in more Bonus XP for character creation.

Optional Rule: The Referee may declare that for character creation only, Bonus XP can be used to raise ability scores for a 1-for- 1 cost.

KNIGHT HAWKS SKILLS

This system makes no changes to the Knight Hawks skill system. The AD skill requirements still hold for Knight Hawks skills. Further, Knight Hawk sub-skills cannot be purchased individually. Space ship components being as complex as they are, dabblers and hobbyists never live long enough to pass on their success stories. I've included the scaled KH skill requirements from Menoitios's article from Issue 10.

Knight Hawks Skill	Alpha Dawn Skill Req.	Level Requirements					
		1	2	3	4	5	6
Pilot	Technician	2	2	3	4	5	6
	Computer	1	2	2	3	3	4
Engineer	Technician	2	2	3	3	4	4
	Robotics	1	1	1	2	2	2
Astrogration	Computers	2	2	3	4	5	6
Energy Weapons	Beam	2	2	3	4	5	6
Rocket Weapons	Projectile	2	2	3	3	4	4
	Gyrojet	1	1	1	2	2	2

COMPLETE LIST OF ALPHA DAWN SKILLS AND SUB-SKILLS

Animal Trainer	
Analyze Animal Behavior	20% +level x10%
Animal Training*	10% +level x10%
Body Speak	100%
Ride Mount	70% +level x10%
Artisan (Intellectual)	
Appraise Art	10% +level x10% + notoriety adj.
Create Art	30% +level x10% + situation adj.
Create Masterpiece	10% +level x10%
Interpret Art	10% +level x10% + notoriety adj.
Restore Art	40% +level x10%
Computer (Technological)	
Bypass Security	30% +level x10% -prog level x10%
Defeat Security	60% +level x10% -prog level x10%
Display Information	80% +level x10% -comp level x10%
Interface Computers	30% +level x10% -comp level x10%
Manipulate Program	50% +level x10% -prog level x10%
Operate Computer	100% +level x10% -comp level x10%
Repair Computer	40% +level x10%
Write Programs	special
Demolitions (Military)	
Set Charge	30% +level x10%
Defuse Charge	50% +level x10% - level x10%
Environmental (Biosocial)	
Analyze Ecosystems	30% +level x10%
Analyze Samples	50% +level x10%
Concealment	10% +level x10%
Find Directions	50% +level x10%
Make Tools/Weapons	100% if material available
Naming	100%
Stealth	20% +level x10%
Survival	40% +level x10%
Tracking	30% +level x10%
Linguist (Intellectual)	
Human Languages	50% +level x10%
Dralasite Languages	50% +level x10%
Yazirian Languages	50% +level x10%
Vrusk Languages	50% +level x10%
Pan-Galactic Language Comprehension	60% +level x10%
Martial Arts (Military)	1/2 DEX or 1/2 STR +level x10%
Medical (Biosocial)	
Activate Freeze Field	30% +level x10%
Administer Drugs	100%
Control Infection	50% +level x10%
Cure Disease	40% +level x10%
Diagnosis	60% +level x10%
First Aid	100%
Major Surgery	20% +level x10%

Minor Surgery	40% +level x10%
Neutralize Toxin	30% +level x10%
Situational Awareness	special
Surveillance	40% +level x10% - 1/2 target INT
Stealth	60% +level x10%
Spy Gadget (Espionage)	
Computer: Access & Operate	80% +level x10% - 10% x prog or comp
Detect & Deactivate Defense/Locks	40% +level x10% - security level x10%
Operate Machinery	50% +level x10%
Recognize/Use Spy Gadgets	40% +level x10%
Identify Robots	100% +level x10% - Robot lvl x10%
Technician (Technological)	
Deactivate Alarms/Def.	40% +level x10% - alarm level x10%
Detect Alarms/Def.	60% +level x10% - alarm level x10%
Open Locks	50% +level x10% - alarm level x10%
Operate Machinery	50% +level x10%
Repair Machinery	40% +level x10%
Telepath (Mentalist)	
Awareness	40% +level x10%
Clairaudience	20% +level x10%
Clairvoyance	20% +level x10%
Dominion	15% +level x10% - target LOG
Empathy	30% +level x10%
Read Thoughts	80% +level x10% - target LOG
Send Thoughts	70% +level x10%
Suggestion	40% +level x10% - target LOG
Weapons (Military)	
Beam Weapons	1/2 DEX +level x10%
Gyrojet Weapons	1/2 DEX +level x10%
Melee Weapons	1/2 DEX or 1/2 STR +level x10%
Projectile Weapons	1/2 DEX +level x10%
Thrown Weapons	1/2 DEX +level x10%
Others	(Individual, not selected as a group)
Thievery	1/2 DEX +level x10%
Deductive Reasoning	1/2 INT or LOG +level x10%
Athletics	1/2 STR or STA +level x10%



ADVENTURE BOTS!

By C.J. Williams

PART THREE: FINISHING TOUCHES

In the previous Adventure Bots articles, we explored the finer aspects of role-playing a robot's personality. In this issue we will discuss things you can do to make your robot a larger part of the adventure. Role-playing a robot requires more than just knowing your robot. You must also know the world around your robot, what the robot culture is like in the setting, what your robot knows, and be able to respond in ways similar to a character, if limitedly. These things affect your robot PC and how they interact with the world around them. Here are those little finishing touches that can help your robot stand out, as well as some information for the Referee.

WHAT A ROBOT KNOWS

You might be surprised to learn what your robot knows. Your robot is privy to things other characters may not be.

ITS EYE IS ON YOU

Fourth level and better robots observe and record everything. Even second and third level robots record certain statements or actions based on their owner's needs or the needs of their guests in order to improve their services. If the second or third level robot's player wishes, he may keep notes on specific types of things that would affect their service. A player of a fourth level or better robot does not need to record notes to improve service, as they can automatically adapt as they learn. However, the robot's master must remember that anyone hacking the robot's memory is going to learn every detail that the robot has witnessed and could sell the information or use it against them.

LEARNING THROUGH THE ROBOT EYE

The information that a robot learns can, however, be of use to its master as well. The robot might be able to go places the party can't and play back the information or give descriptions of areas they otherwise would have no access to. This can be good for scouting, casing, espionage, and information

gathering.

MEMORY WIPES AND MAINTENANCE

If a robot's memory is a threat to its master, memory wipes may be necessary to ensure the master's privacy. Robots that have had their memories wiped still know how long they have been in service and how many memory wipes and maintenance checks it has had. When their memory is wiped, all the settings are defaulted to factory specs, though some residual data may remain (See the article *Adventure Bots!, part 1* in issue #13). So each time your

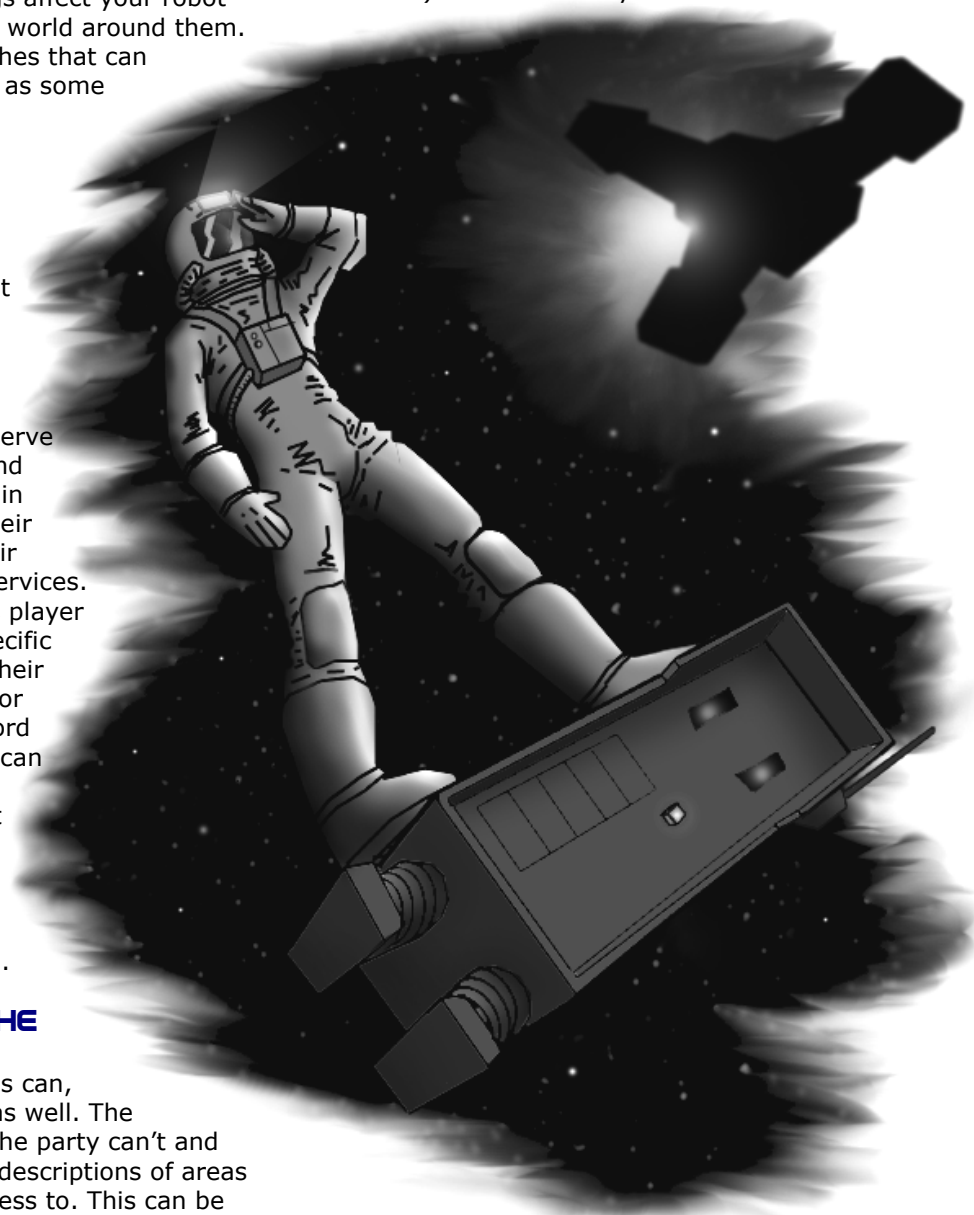

Artwork by C. J. Williams

robot undergoes a memory wipe or maintenance check, write the Frontier date, if possible, the Gregorian date, or the period of time between each service.

FUN WITH ROBOTS

Each article in this series provides plenty of opportunities for having fun with your robot; here are some more ideas apart from those mechanics and story elements. Robots are particularly good for using as comic relief, or just keeping the adventure entertaining.

Body Swapper. The robot is a computer A.I. that can use any remote robot body to act. Swapping bodies in middle of a conversation, or activating a body at the most unsettling moment, or walking out of the shadows when a bad guy is expected can make for fun moments.

Booper Bleeper. A robot without a voice box, making beep sounds, can be lots of fun. Besides using your own whistles and tones, you can use tone-making device to relate the robots ideas and concerns, though tools such as those should be used sparingly to express very specific ideas so as not to annoy anyone by too frequent use. You could also use static and other sounds in association with the beeps or instead of the beeps. The robot and its master could actually work together to produce beeps each time the robot's master is about to cuss. The robot can also use its beeps or static noises as a means of expressing pseudo-emotional faux dialog.

Disembodied Robot. Due to the robot having to communicate through alternative means, the robot may be present by some sort of proxy, such as a com device or remote probe with an open channel. Its voice can pop in to give input and ask pertinent questions. This can be made to produce an ominous or unsettling effect, or even startle the characters when they think everything is quiet (using a little louder voice for such a circumstance would bring across the effect).

The Fearless One. Life just seems to be so easy and care-free for this robot. This requires cooperation with the Referee. The player and the Referee pact that instead of rolling success, the Referee will more often than not determine whether the robot can do something or not without need of a roll. While not particularly hair-raising, it does allow the player to get reasonably over the top or comically adventurous. If used sparingly, this can help catch players off their guard for greater effect at the right time.

The Happy Vehicle. Whether a ship's A.I. or a robot vehicle, the expression of robot quirks or a programmed personality could be humorous and fun. A happy military Explorer vehicle, argumentative Mine Layer, or absent-minded Assault Scout could add substantial entertainment to the campaign.

Just Dropping In. When seeming to be nowhere in sight, will drop in out of nowhere to answer a query or respond to its name, and then when not in action, completely drops out of sight, as if it weren't even

there, perplexing anyone who notices its sudden absence. It might even be in middle of talking and suddenly its voice fades out just before the characters realize the robot has disappeared again.

The mute. Even mute robots can communicate. If your robot is without a voice, there are plenty of ways to let the party know what you want or your opinion, such as nudging a character, using your actions to express dissent or show the only kind of excitement a robot knows, which is doing its assigned task speedily and efficiently. It could also lead to some amusing moments as the robot attempts to get its master's attention before he is captured by the bad guys.

Robot Head. Just like people, anthropomorphic robot heads contain the robot brain. But unlike people, if your robot gets blasted to pieces, the head can still be operational if the Referee agrees. In other cases, the robot may be constructed as simply as a head to begin with, or in a shape that resembles a Picasso-style head. A robot head can open opportunities for some amusing gags.

Sight Gagger. The robot just drifts on by while dialog is happening. This can be demonstrated by moving your hand through the air with a quiet ambient sound effect. This enhances and makes light of the fact that the robot is generally ignored as a piece of furniture. This is an excellent opportunity to perform sight gags in the background. Don't get too carried away with it, of course, but it's a great way to get a laugh at the right time or to lighten an otherwise serious mood.

ROBOTS AS FRIENDS

One of the outstanding features of robots in popular entertainment is the close ties they share with their masters. What causes this is their being ever-present in their master's service, as well as being a point of concern for their master, just as a reliable car, except this car can move on its own, giving it more personality. The company that designed your robot wants your robot to develop a close relationship to its master. The attachment that a master develops to his or her robot is a fundamental design standard that all robot companies seek to enhance. Thus remember that the robot's programming causes it to seek to be friends with its master, no matter how annoying either of you are. In designing a robot, there are four fundamental aspects that companies consider when developing robots: needs, dialog, attendance, and asset.

NEEDS

Yes, robots have needs, so be needy. By giving your robot's master reason to attend to the robot, such as tracking the robot down, cheering the robot on, cleaning the robot up, fixing the robot, and responding to the robot's concerns, you can cause the master to develop an attachment to your robot, even if he or she pretends to be aloof. Sometimes the master becomes so accustomed to attending to the robot that they perform the required task without needing to be prompted. Other times, however, the robot may have to remind their master to attend to those needs, perhaps even to the point of annoyance (Some people

won't act unless nagged. This could make for an interesting dynamic).

DIALOG

When there's time to think in the adventure, whether your robot speaks or not, there can be a dialog between the robot and its master. The robot may ask a pertinent question, give a questioning bleep, or offer a satirical or sympathetic comment or bleep.

If there is something that the party is discussing and you realize that your robot character would be perfect for the mission, speak up in character to let the party know. "Perhaps I could be of assistance", the robot says. Or it scoots into the midst of the party and gets attention, "Beewwwwwwp — schschsch. Beoop-boop — wrpp?" If the party doesn't get it, the robot can do something to demonstrate its idea in a kind of pantomime.

Also, a robot with a poly-vox must first attempt to seek permission to shut down from its master. If it can't find its master within a reasonable period, it may shut down on its own.

ATTENDANCE

Your robot PC should be ready for serving its master at every opportunity. Just by always being by its master's side the robot makes itself a constant companion, a fixture upon the character's life. Of course, you don't want to do this to the point of annoyance. Occasionally the robot must perform its function solo for whatever reason.

ASSET

Developing friendship is a give and give alike situation. Just as the master looks after the care and maintenance of the robot, the robot looks after the master. Robots are designed to be flexible, applying their programmed talents where possible to become indispensable to their masters. To take special advantage of this, think of your robot's programs and its primary purpose, then think of every way to which the robot would apply its programming and purpose to serve the needs of its master. Even long term needs are considered, meaning that sometimes an immediate duty might be sacrificed for the long term duty to provide greater impact upon the master's life and wellbeing. This may require ingenuity on your part (See the Robot Ingenuity subheading below). Perhaps the robot goes off to take care of a task and ends up in the right place at the right time to get its master's afterburner out of trouble. On the other hand, each of the master's commands must be obeyed in a timely manner so long as it does not conflict with your robot's root directives (See *Adventure Bots!*, part 1 in issue #13).

ROBOT INGENUITY

Previously we have discussed the details of role-playing a computerized chunk of metal, but now let's discuss role-playing this hardware with more complexity and a little creative license.

Sometimes you have to go beyond what a robot might actually do to express the heroic nature of your robot, but do this without going beyond the robot's established character. A robot of level three or higher is a decision-maker, not just of cold yes or no prerogatives, but taking external considerations into account. A robot can be observant and take more factors into account than just the immediate object or situation. And the more complex the robot, the more complex its decision making.

Robots often surprise their masters with their ingenuity. Unexpected responses can often catch the master off guard. When the robot is queried, the master often discovers that there was a matter that they didn't realize was even being considered by the robot.

Levels 3 and 4. Though still fairly rudimentary, level 3 or 4 robots can consider such factors as planned appointments, available ammunition vs. ammunition requirements, vehicle and character speeds, altitudes, preparation times, and estimated arrival times. The hard facts do not often escape these robots, and their understanding of how these things affect any particular decision can often be uncanny to the point of seeming psychic. If they are programmed with Making Tools and Improvised Shelter skill programs, then they can access those programs to respond with the right object for the right situation.

Levels 5 and 6. The complexity of these robots is staggering. Even their programming is so complex as to challenge even emotional logic. Level 5 and 6 robots are not only able to more fully consider the hard facts of level 3 and 4 robots, but are also able to include sentient emotional considerations, though unable to experience the emotion themselves. They are able to adapt to strategies and include abstract principles and concepts in their decision making. They can improvise tools and hiding places in ways that are almost sentient (though they cannot improvise if there is not a pressing need to do so, nor can they be commanded to improvise on the spot, though "I don't know...Improvise" is a legitimate request that a higher level robot can fulfill with some deliberation and analysis. Non-sentient robots cannot, however, *invent* anything.)

ROBOT TREATMENT AND . . . RIGHTS?

What rights do robots have? Ask your toaster. Destroying a robot is no greater offense than destruction of private property, and the higher the value of the robot, the greater the offense in that respect; but it is nowhere near the value of murder. Taking a robot is not kidnapping, but theft. Maliciously damaging the robot of another character is vandalism.

Unlike animals, a robot does not recognize if its master is being abusive. It simply accepts any abuse with quiet resignation. But it may have no problem telling other robots when they are impinging upon it, if such is part of its programming or a quirk.

VIEWS ON ROBOTS

How a robot is valued or treated is dependent upon each individual it encounters. Most living beings have considered the rights of robots, even if they are not proactive in the issue.

There are many philosophies regarding a robot's conscious awareness. Some believe robots should be afforded more respect than a vehicle or computer, while others go so far as to want to give full independence to all robots. The latter view, of course, is the concept of extremists who generally carry some religious or superstitious belief regarding autonomous systems. Still others believe that all development of A.I. should be permanently banned.

There are those who do not ever get attached to robots, seeing such attachment as nonsensical or perhaps forbidden. They may simply see robots as a means to an end and nothing more. Or perhaps their professional sentiments, such as robot designers or dealers, give them a clear view of robots as nothing more than computerized machines performing their assigned tasks.

As a fourth level or better robot comes to know its master's habits and expectations, the robot can develop some amount of independence and its own expectations about what its master will or won't do, or does or doesn't expect. It can even develop judgments about what is publicly acceptable or overlooked, and what is balked at or even offensive. A robot always starts out cautious, unsure about the world, and only becomes more independent with time and experience.

However, any robot designer will tell you with confidence that a robot without the controlled chaos imposed by positronic pathways, A.I. programming, and a learning chip cannot be self-aware. It is impossible. Even still, without the highest degree of A.I. programming, the robot will be psychotic at best, if not given imposed directives to guide its thinking and conduct.

First to fifth level robots in Star Frontiers are not particularly aware of robot rights or of their fellow robots in general. Other robots are simply other objects with which to communicate or ignore. Unless the robots are sixth level, a conversation between two robots will be wholly purposeful, in order to give or receive information or commands. A robot will recognize another robot as such, but it will not do anything more in regard to another robot than what it is specifically programmed to do or must do according to its assigned task.

ATTITUDES TOWARD ROBOTS

There are a variety of reactions to robots from resentment to disregard, from animosity to amorous, from enslavement to friendship. There are racial reactions and character reactions, even personality differences. The reaction to robots is diverse, but the predominant attitude is one of appreciation similar to one's appreciation of a car. Some masters give their

robots special paint jobs and fix them up with all the latest gear, if only to show their mastery over the machine. Others are simply meticulous in their robot's care, while still others just let the robot wear out and then replace it.

But the reactions of those who are not the robot's masters can be even more diverse, for reasons that are cultural or personal. While personal reasons could make for a whole article, or even a book, on their own, let us look at the common racial cultural reactions. Note the Racial Reaction Modifiers table below. The reasons for each reaction is described.

Table 4: Racial Reaction Modifiers

Race	Modifier to	
	Basic	Model Complex
Dralasite	+05	+10
Human	+05	+05
Humma	-10	-20
Ifshnit	+05	+10
Mechanon	--	--
Osakar	--	--
Sathar	--	--
S'sessu	--	--
Vrusk	--	--
Yazirian	-5	-10
Zethra	--	--
Zuraqqor	-5	--
Aboriginal, Metal	+20	+30
Aboriginal, Stone	+10	+20
Aboriginal, Cave	-15	-25

Aboriginal cultures have various reactions generally dependent upon their level of social development. Cave aborigines have a fear of anything crafted that moves upon its own. They don't understand it and fear what it can do. To them it is a moving stone with fire in its eyes.

But to mildly more advanced stone-carving aborigines, they have a curiosity about the robot that keeps them focused on it. Not having developed any religious society yet, and having an idea of what can be constructed with hands and how fire is made, they give constant attention to it, but nothing more. Its fiery lights also do not scare them.

The metal age aborigines have developed enough to understand that metal, particularly polished metal, represents the divine, and to them, a robot may even be a god, or at least the servant of a god, and their fiery lights may even be considered the forge of heaven's fury. If they bow down and worship the robot, it just represents the level of their cultural development. They will eventually get over it, as they get to seeing the relationship of the robot to its masters. It then becomes more likely that they will begin to see the fleshly characters as gods, up until they see them bleed, at least.

Dralasites find joy in playing games with robots, toying with their logic and making them act in ways not typical to their programming, but mostly they just like having them around as novelties and playmates.

Ifshnits have a positive reaction to robots because they see the value in credits of a quality robot model. They may be inclined to investigate a robot closely and inquire of its capabilities, all the while judging its worth should the opportunity arise to trade for it or assist in trading it.

Humans depend greatly on robots and generally have a positive reaction to robots, typically dependent upon their appearance. A "cute" robot will generate a general sense of appreciation from humans, and simply industrious robots may generate a sense of gratitude for their service, though this is not universal. Humans tend to take a stand as to whether a robot is humanistic or simply a machine to be wielded.

Humma despise and distrust robots and are certain that they are susceptible and even subservient to Mechanon, or that they will become like Mechanon at any moment.

Mechanon are indifferent to all non-sentient robots. However, sentient robots are respected for their sentience and invited to join mechanon society as equals.

Yazirians to a lesser degree also distrust robots not programmed by them personally. Yazirians are inclined to view robots as objects only, with no value as companions. Yazirian religious culture, however, is mostly to blame for their distrust of robots, believing them to be the ultimate expression of sentient opposition to the divine. They may work with or even on robots as occasionally necessary evils, but robots are not very common on Yazirian worlds. Though they view them as a better alternative to slave labor.

ROBOT OPPOSITION

Not all members of every race respond to robots as described above. Some are simply opposed to the use of robots on various grounds.

WORKER'S RIGHTS

Workers often complain about robots taking jobs away from organics. Labor unions fight hard to keep their breathers working. When robots are brought in to replace jobs, furor can quickly ensue.

While some laws exist to protect workers from losing jobs without good cause, they are few and far between. Lawmakers are afraid of holding back progress, but particularly are afraid of losing the funding of their corporate backers.

When robots replace jobs, the workers could end up sabotaging the machinery, forming an uprising, or even killing an executive. The violence can quickly escalate. Of course, the violence isn't typically directed at the robots unless the old workers storm the plant en masse. Their focus is typically to hurt the bottom line, though some individual workers or their children might direct their rage at robots in general. Other times, particularly skilled individuals may reprogram the robots to do the damage and sabotage.

WAR VETERANS

In combat, some organic veterans create a long-standing prejudice in their minds against enemy combatants. If those enemy combatants are all robots, they may see every robot, and not just the corporation that used them, as a lifelong enemy. They may seek to destroy robots in private. This is more common to happen to robots because there are greater laws and more intellectual resistance to killing organics. Whole regions can be affected by this mentality where one side maintained a robot army.

This resentment towards combat robots may even be brandished against the corporations that manufacture them. These corporations tend to be the most secure and suspicious corporations around, as a result. A manufacturer of standard robot models tends to be more lax in their security, but makers of combat models have security measures covering every inch of their compounds.

ANTI-A.I. ORGANIZATIONS

No matter what their reasons, many feel that artificial intelligence should be banned. There are many anti-A.I. organizations. Some are simply lobbyists, while others are extremists, bombing A.I. robot manufacturers or raiding robot manufacturer corporate offices and holding people ransom while destroying any A.I. robots in view and very purposefully sparing non-A.I. robots to make a clear statement of their reasons for the raid to demonstrate their clarity of purpose.

PARANOIDS

Some people are suspicious of all robots, fearing that the robot is spying on them, going to kill them, or has some other nefarious programming that is certain to do them in. Though not very common, these individuals are the most unpredictable and dangerous to robots. These individuals are typically mentally disturbed, though some may have legitimate reason to fear because of their many enemies.

PREJUDICE

In public, whether lobbyists or extremists, jilted workers or shell-shocked veterans, these individuals may act very negatively toward robots, at least of a kind, refusing to deal with or be served by them. Neither will they let one pass without incident anywhere they control. Because prejudice is not a trait of any one particular organization or experience, prejudice against robots is common. Many places refuse to allow admittance to robots, whether for these grounds or on grounds of possibly being designed to kill. Sentient robots are no exception and are sometimes affected by the worst of it all.

ROBOT CONTROVERSIES

Lobbyists on both sides of the fence regarding robot rights have issues they hold up as sticking points.

Memory Wipes. Regularly scheduled memory wipes are recommended by all robot manufacturers to prevent development of program quirks and other anomalies of personality. This does not go over well with robot rights activists who regularly stage rallies outside of robot maintenance facilities to discourage

the practice. Due to their low membership, these rallies are generally focused and travel around, not typically seen at every robot maintenance center. Usually they focus on holo-vid ops to help spread their cause (or keep it alive, as the case may be).

Haywire Robots. Robots gone mad is a frequent theme of holo-vid movies and is a legitimate fear, as stories of robots killing people abound in the media, particularly through online search engines. Though such things usually happen because of the negligence of the robots' masters. These incidents keep the anti-robot lobby alive and very much larger than the robot rights activists.

MISSING AND EXPLOITED ROBOTS

Robots are one of the most lucrative black market goods and are thus frequent targets of looters, insiders, and thieves. They will divert them from the assembly line, have them 'drop off the truck', steal them from homes or businesses, or simply snatch them off the street. The stolen robot is then given a memory wipe if necessary and repurposed. They then turn around and sell the robot at a reduced cost or use it for trade or in place of slave labor. Though due to the reprogramming time and cost required, organic slaves are still the most common.

Black market robots are often given illegal or shady programming and attachments that can't be acquired on the open market. (See "Adventure Bots!, part 1" in issue #13) Some robots who have been witness to robot thieves, perhaps having been in their company or possessing some residual memory from a previous abduction, may come to be suspicious of anyone carrying a stun weapon.

Non-sentient robots do not "run away". They may be misplaced and forgotten, or they may be stolen or damaged, or simply haywire or confused. If the robot is missing, the master can be sure that the robot is simply unable to return of its own accord or its assigned task has simply taken longer than anticipated. A non-sentient robot of level 4 or lower that is unaware of its rights or unaware that it is suffering anything at all, cannot seek its own independence.

Missing robots may sometimes receive bounties on their heads for their return or "decommission", and usually only because they carry some valuable information or represent a threat to a corporation's bottom line. For that reason, the bounties tend to be private, seeking to call no attention to the situation. Such is usually the case for corporations, pirates, smugglers, and crime syndicates. Such bounties are almost never seen on public access channels.

WORK WITH THE REFEREE

You may have noticed how frequently I have mentioned working closely with the Referee in this series. Despite these articles referring to the robot as a player character, it is in actuality a NPC that a player plays as a kind of Referee proxy. In the first article I pointed out that the Referee usually controls the robots, but may assign a player to roleplay the robot.

The player may also present a robot to the Referee for consideration as a character the player plays. However, the Referee is still as much in charge regarding a player-created robot as one appointed by the Referee.

So the important thing to remember here is that a robot is a cooperation between the player and the Referee, with the Referee sharing equal responsibility for the robot character with the player, as the Referee may often choose to use the robot as a means to advance the story, while the player must struggle to be a part of the story, which requires the Referee to grant some exceptions to the robot that he might not normally give to other characters. But then, often times, the Referee himself is the one playing the robot, so these rules are as much for them as for players.

REFEREEING ROBOT CHARACTERS

If you are a Referee and have read through these articles, you will note that there are unique challenges to Refereeing a robot as much as playing one. Robots cannot be treated like a race. Below we will discuss how to govern certain situations involving robots.

SOME SIMPLE RULES

When running a party with a robot PC, here are a few simple rules to live by:

Cooperation. The Referee has the responsibility to maintain continuity, and thus to make sure the robot stays with his master and that any other circumstance must be commanded by the master or in agreement between the robot's player and the Referee.

Absent Owner. A robot character has greater freedom if owned by an absent master, such as a corporation or benefactor. The Referee could consider passing a secret directive/mission to the robot player as if a latent directive by an absent owner. This can guide the robot's reactions during the adventure.

Consider Feelings. Look after the robot's welfare if played by another player. Consider their feelings and don't be abusive to the robot or allow abuse of the robot within the party unless the abuse is for humor and is okay with the player.

Repair. Make sure that the robot has a means of repair, particularly if it gets disassembled or blasted to pieces. If not, make sure its destruction is memorable, something to be talked about in fond memory.

The second article in this series (Issue #14, p.8) has several ways to help a robot player to make the most of role-playing their robot. These things require almost as much participation by the Referee as the player to make them happen, highlighting the teamwork required to make a robot character an integral member of the party.

HELPING THE PLAYER HAVE FUN

When Refereeing a robot character played by another player, there are things you can do to make roleplaying

a robot more entertaining for the player as well as helping them stay in character.

Relate. Speak to the robot's point of view. Of course, you don't need to speak like the robot itself, but provide only the data that the robot would be likely to take away from the circumstances in a way that sounds very crisp, as if technical, but not so technical that the player's eyes gloss over. Speak in a way the player can clearly understand using straight facts related systematically. For instance, using statements like "object terminated" and "barrier override - complete" can have a dramatic effect on the perception of the campaign as well as the robot player's performance in the game.

Remember, too, that their robot character will not be interested in the aesthetics of the environment, but only what is of potential import to the robot itself. When describing a room to the robot player, only describe the computers that the robot can access, potentially damaging items like magnets, and anything else relating to it. When describing a room to both players of organics and of robots, relate what is important to both, not just one or the other. Though there is no need to provide two separate descriptions. One description that includes information for both should be enough.

Provide Roleplaying Opportunities. It is all too easy to let the robot slip between the cracks. Provide challenges that are tailored to the robot's skill set. Particularly try to provide moments where the robot and its master can work together to provide resolution. You can also make the robot the focus of an adventure, take advantage of its weaknesses as a story element, or simply to introduce the story, provide transition through various scenes, and provide foreshadowing of things to come.

Use the robot character to pick up on things the party might be missing in order to keep the story moving. Don't be afraid to dictate what the robot sees, passing notes if necessary.

Specialize Missions. Sometimes it's fun just to direct the robot in its own side adventures that can have a later effect on the overall adventure. Look for opportunities to give the robot a chance to get the party out of a bind. Setting this up beforehand will go unnoticed when the party falls into your trap, but the robot, after resolving a matter that seemed perfectly logical to the adventure turns out to put the robot in the right place at the right time to get the characters out of the jam.

Consider Tactically. An antagonist will consider all means of getting at the characters, even through their hardware. Whether the antagonist takes direct aim to remove a useful tool from the party or uses the robot to evil ends, such as ransoming it or reprogramming it, the robot is an easy way to get at the party in creative ways. (See "Running a Robot Villain" below.)

Let it Slide. Sometimes there are things that just work well for the adventure or for good comic relief. Allow the player to get by with things that the regular player characters wouldn't normally get away with, simply because the robot is a machine or is not organic. Even heroic moments that would be unlikely can be overlooked just to give the robot that extra panache that makes it stand out. Though make sure that the robot does not outclass the rest of the party. You simply want the robot to be as memorable to the campaign as any other character. This requires some leniency towards the robot player's ideas. The primary goal in regard to the robot should be entertainment for you, the robot's player, and the other players in the party. Remember, you are the one who decides what the robot can and cannot do. Try to make "can" more frequent than "can't", within reason.

IMPROVISING

Due to its utilitarian nature, the party may often find many opportunities to use their robot in ways not specified by the robot's makers. So if the players want the robot to do things outside of its specified duties, think about the following issues:

Already Covered. The robot's function list should be considered. It is possible that the request is already covered by a previous specified function. Or perhaps the Referee may feel that the task could conceivably be covered by the robot's programming, maybe with modifiers applied. If there is a question, the Referee can always adjudicate that the robot's programming was already made to adapt to such a situation. However, for some things it may be too obvious that the robot would not be able to handle the request without special programming.

Abuse. The Referee should always consider whether a request can be abused in the current or other situations not immediately apparent, or would likely be used so frequently as to give a greater advantage over all. A case-by-case determination may then be considered: perhaps a permanent negative modifier may be applied, or maybe the robot must accept a roll on the Quirks and Glitches table (See the first article in this series in issue #13) each time the task is performed.

Learning Chip. If the robot has no learning chip (It is level 3 or lower), it cannot interpret requests and adapt to requests outside of its programming. The new function must therefore be programmed into the robot. A skill check must then be made to make sure that the function is inputted in a way that the robot can complete the function.

If the robot is above third level, a request can be made of the robot without programming a specific function if it does not involve modifying the use of a specific tool, or other carefully considered object or situation outside of the robot's programming. The Referee should inform the Robot Technician's player if a function must be programmed, citing any specific considerations. Situational modifiers may also apply.

Required Actions. If the new task is approved, the Referee should determine the necessary actions, tactics, and skill checks required to complete the task. If it is simple enough, a single roll may be determined for success. However, if it is a complex system of skilled actions required, then each skill must be checked to complete the task. Tasks requiring multiple rounds may even require multiple checks, such as combat, which must have a check each round.

Task Failure. If the Robot Technician fails the skill check to modify the robot's functions properly, it might be randomly determined (Referee's judgment) that somewhere along the line, the robot was unable to complete the task as instructed. A failed check can result in unexpected and even amusing results. Perhaps the robot may perform the task poorly or it becomes confused by unanticipated circumstances. It may even complete the task though missing a step along the way or return prematurely. It would be humorous and deadly if a robot sent to plant a bomb shows up at the door with the bomb in hand and counting down because it failed to complete every part of the task. Such circumstances can force the characters to have to think on their feet or backpedal and have to make up lost ground. The Referee should be ready to mine the situation for drama or entertainment.

RUNNING A ROBOT VILLAIN

Robots make for particularly fun or intimidating villains. Whether the robot is haywire, programmed with a psychotic personality, or a sentient criminal mastermind, their particular brand of impersonal murderous intent or cold decision-making can be chilling.

Robots are not limited in the same way as organic characters. (See the subheading "What's Different About Roleplaying Robots?" in the first article in this series in issue #13.) Due to their immunities and fearlessness, robots are able to press the player's characters in ways other villains cannot. For instance, a robot can cling to devices in the depths of space, survive extreme temperatures, or walk through deadly gas clouds unfazed. Never do they need a spacesuit, though using a spacesuit to provide an unexpected slow reveal of an anthropomorphic robot within can be particularly unsettling. A robot villain will seek to destroy the characters using the things for which it is strong and which the characters have no effective defense.

One such strength is a robot's tireless and relentless nature. Where the characters need moments of rest and to eat, the robot never rests until its energy reserves are exhausted. Even when the robot is recharging, a Referee can use its seeming stillness as a means of inspiring fear. Its resistance to heat and cold can also be exploited, though the characters can still use such things to slow it down or affect its systems. For instance, cold slows down processors, while heat causes processors to misfire or even shut down, leading to quirks and glitches.

Even trusted robots can be used as antagonists. As mentioned in the first article in this series (Issue #13), a friendly robot may be reprogrammed to set a trap for the characters, lead them into a dangerous situation, calculate the wrong jump coordinates, call the bad guys to their location, mistranslate what is actually an instruction to the robot itself, or provide valuable information to the bad guys, even if only by being hacked. A simple maintenance robot that the characters don't normally interact with could turn out to be a spy or saboteur traded in at some point with the original. Or perhaps the corporate robot loaned to the party has a secret directive to kill the party when the mission is complete or to sacrifice party members for the purpose of passing an alien organism through quarantine.

Robot hordes can be particularly scary, especially when a robot villain controls the horde. It can communicate with the horde through a link that is equivalent to mass telepathy. It can even control the computerized machines in robots in a manufacturing facility. Its ability to produce the robots and control machines that the characters must pass increases the jeopardy that much more. Even if the facility is destroyed, the robot can simply reproduce its horde somewhere else, perhaps with upgrades to reflect what it learned from the previous encounter. This allows the robot's threat level to increase as the characters increase in skills and skill levels.

Perhaps the most intimidating factor in a robot villain is that even if you destroy it, it could still be rebuilt and come back later, perhaps in a new and better body and learns from its mistakes.

SERIES BIBLIOGRAPHY

Adventure Bots! parts 1 to 3, though containing much original mechanics and information, culled much information from other sources. The author would like to acknowledge and give thanks to those who came before:

- Paranoia – The Bot Abuser's Manual**, by Ed Bolme. West End Games. 1992.
- Cynabar's Fantastic Technology: Droids**, by Drew Campbell and Eric S. Trautmann. West End Games. 1997.
- d20 Future**, by Christopher Perkins, Rodney Thompson and JD Wiker. Wizards of the Coast. August 2004.
- d20 Future Tech**, by Rodney Thompson and JD Wiker. Wizards of the Coast. February 2006.
- Star Wars Roleplaying Game: Saga Edition Core Rulebook**, by Christopher Perkins, Owen K.C. Stephens, and Rodney Thompson. Wizards of the Coast. May 2007.
- Scavenger's Guide to Droids**, by Rodney Thompson, Sterling Hershey, Patrick Stutzman, and Robert Wieland. Wizards of the Coast. November 2009.

For issues or comments on this article, go to <http://mystarfrontiers.blogspot.com/adventurebots>.

TELEPORTATION TECH

By Scott Mulder

THE ART & SCIENCE OF ENERGY TRAVEL IN THE FRONTIER

WELCOME TRAVELERS!

"Welcome to the En-Trav Teleport Center. We hope you enjoy your journey with us today. If you are new to teleportation travel please take a moment to review the safety chrono-vid enclosed with your ticket. First time "Beam Riders" should be aware that this cutting edge transportation technology is a process that converts matter into energy, transmits that energy from one place to another, and then instantaneously reassembles that energy back into matter. In all fairness, some critics do consider teleportation to be one of the riskiest ways to travel in the Frontier. However, if you need to get someone or something to somewhere fast this is definitely the fastest and safest way to do it. A trip that normally takes hours by air car can be accomplished in mere minutes with teleportation. Whether this is your first time or you are an experienced "Beam Rider" you will find the rewards of near instantaneous travel far outweigh the risks."

Pg.3 Beam Riders Guide
En-Trav Corporation.



Author's Note: This article is intended to introduce a set of optional rules and guidelines for the use of teleportation technology in the Star Frontiers™ role playing game universe. Teleportation is a popular science fiction theme or plot device that can add a new and interesting twist to your game sessions. Referees and Players can use this resource either in whole, or in part, to incorporate teleportation into their adventures and campaign settings. Referees are encouraged to expand upon these rules and guidelines as needed to best fit your game.

TELEPORTATION IN THE FRONTIER

Teleportation was first developed by scientists at the Blue Star Mining Corporation who were experimenting with a new process to isolate and extract valuable materials, such as Federanium, at the molecular level from unrefined ore. The Blue Star Scientists found that once the minerals had been converted into energy, they could be separated from the ore, transmitted to another area, and then converted back into matter.

When the Blue Star Mining Corporation realized that their new mining process was actually a very efficient teleportation machine they quickly sold the design for a significant fortune to the Pan Galactic Corporation. At the time, Pan Galactic was the only commercial enterprise with the resources available to develop this new technology. The first teleportation devices manufactured by Pan Galactic were called Matter Conversion Transmitters (MCT) and were designed to teleport inorganic materials and cargo within a closed circuit system.

Despite a respectable safety record, MCT's were still considered too dangerous, and controversial, to use for teleporting live passengers. However, this mindset quickly changed when a Pan Galactic medical scientist named Doctor K'vrek Vor discovered a way to interface a medical bio-scanner to an MCT unit for the surgical removal of diseased biological tissue via teleportation.

What Doctor Vor had discovered was that the bio-scanner was able to translate information about organic tissue into a layered data stream that the MCT's processor could understand. Five years later, using Dr. Vor's research, the Pan Galactic Corporation began construction of its first teleportation facilities using a closed circuit network for the transport of both cargo and live passengers.

During the opening ceremony for the first closed circuit teleport network the Director of the Pan Galactic Teleportation Technologies Division demonstrated the successful teleportation of a common laboratory rodent to a teleport terminal in a sister city over two hundred kilometers away.

Two years later cost over-runs began to plague the program and Pan Galactic decided to spinoff their teleportation technologies division into a new subsidiary company called En-Trav (An anagram of Energy and Travel). This new company was created to oversee the development, production, and marketing of all Pan Galactic teleportation technology.

Under the direction of Res Tallagan, En-Trav developed the first Universal Access Network (UAN) teleportation system which allowed passengers to teleport to and from any teleportation facility within range without the need of a closed circuit network. This new system was made possible through a quantum leap in high energy signal transmission technology which dramatically increased the range of teleportation signals.

Tallagan believed that universal access teleportation was the future of public transportation but safety concerns, political contentions, and expensive operating costs prevented the program from ever becoming widely available to the public.

TELEPORT SYSTEM COMPONENTS

Regardless of manufacturer almost all teleportation systems require the same basic components to operate. These components include a skilled teleport operator, teleport control computer, industrial grade molecular scanner, medical grade bio-scanner, matter conversion transmitter (MCT), data interpreter unit, signal transmitter array, signal receiver array, sending and receiving terminal pods, containment shielding, and power generators.

Teleport systems are designed in a variety of models for commercial, industrial, and military applications. While each of these different models may provide a variety of different features or program options they all use the same basic components. This standardization of components allows teleport operators and technicians to work on a variety of systems without the need of additional training.

Teleport systems which are part of a larger network may require additional components and infrastructure specific to those networks.

Component	Cost
Control Computer	30,000 Credits
Teleport Program	20,000 Credits
Diagnostic Program	6,000 Credits
Security Program	8,000 Credits
M.C.T. Unit	575,000 Credits
Molecular Scanner	200,000 Credits
Medical Bio-Scanner	150,000 Credits
Containment Shield	60,000 Credits
Transmitter Array	250,000 Credits
Receiver Array	250,000 Credits
Data Interpreter Unit	125,000 Credits
Terminal Pod	55,000 Credits
Large Terminal Pod	85,000 Credits
Power Generator	200,000 Credits
CCN Buffer Unit	65,000 Credits
TRN Relay Unit	150,000 Credits
TRN Capacitor	25,000 Credits
Encryption Program	30,000 Credits
HALO System*	375,000 Credits

*HALO Systems are restricted military items

TELEPORTATION SEQUENCE

While some details of the teleportation sequence are considered proprietary trade secrets owned by the Pan Galactic Corporation, the essential process is composed of Five Phases. From start to finish the process of teleporting an item or passenger from one place to another takes about two minutes to complete.

Prior to beginning the teleportation sequence, the Operator will use the control computer to locate and target the receiving terminal pod for the destination of the teleport. This procedure connects the sending teleport terminal with the receiving teleport terminal forming a dedicated network. If the teleportation requires a relay network the Operator will locate and target the relay connection at this time as well.

The sequence begins with the Scan Phase when the subject to be teleported enters the teleportation terminal. In this phase the subject to be teleported is first scanned by the molecular composition scanner and then by the bio-scanner. During the Scan Phase the teleport operator will be able to determine if passenger or cargo is safe to teleport.



Upon completion of the scan the teleport operator will begin the Diagnostic Phase and conduct a complete diagnostic scan of the teleportation system. During this phase the control computer will check the sending terminal, receiving terminal, and transmission equipment to ensure they are all operating properly.

When the diagnostic has completed the teleport Operator will begin the Test Phase by sending a test signal to the receiving station to check transmission integrity.

If the test signal is received successfully by the receiving terminal the teleport operator will initiate the Teleportation Phase. During the Teleportation Phase the teleport pod's MCT unit disintegrates the subject into energy which is then transmitted to the receiving teleport terminals MCT where it is reintegrated back into matter.

Upon being reintegrated the subject is scanned by the receiving terminals molecular composition scanner and bio-scanner to ensure the teleportation occurred successfully.

MAXIMUM OPERATIONAL RANGE

Teleportation transmissions are very complex, high power signals containing a vast amount of layered information. The complexity of the data stream itself limits the range a transmission can be sent. Any loss of the signal's integrity could jeopardize the safety of the teleport. The maximum safe operational range of current teleportation technology is 10,000 km (One Hex in SFKH). Any teleportation beyond this safe range dramatically increases the risk of transmission disruption and loss of signal integrity.

Any attempt to transmit beyond the maximum operational range without the assistance of a Relay Network will result in a penalty modifier of 25% on the Passenger or Cargo Teleport Table per 1,000 km.

CLOSED CIRCUIT NETWORKS

The very first teleportation facilities built by the Pan Galactic Corporation utilized a "Closed Circuit" teleportation network also known as a Teleport Grid. Originally designed for public transit applications, and aptly nicknamed the "quantum subway", closed circuit teleport networks are always ground based systems.

The primary advantage to this system is that it is far safer than standard Universal Access Networks or Transmission Relay Networks because the signal is contained entirely within the network itself. The primary disadvantage to this system is that it cannot transmit or receive a teleport signal outside of the closed network.

One major advantage these networks have is the unique ability to re-capture a signal in the event that there is a disruption in the transmission. As long as power is not lost to the system a skilled operator can recover most signals which are disrupted or lost due to a malfunction. One of the most dangerous threats to a closed circuit network is power loss. All teleportation grid facilities have their own dedicated power generating systems with redundant back up and emergency power systems. If there were a complete loss of power to the system all cargo or "passengers" would be lost in transit with no possibility of recovery.

UNIVERSAL ACCESS NETWORKS

The standard teleportation system in use throughout the Frontier is the Universal Access Network (UAN) which was created by the En-Trav Corporation. This system uses a high energy, directed beam transmission technology and can either be ground or space based. UAN systems are open access networks which can send or receive transmissions to and from any UAN terminal. While UAN's are the newest technology they are not as reliable as the older Closed Circuit Networks and are more prone to malfunctions and breakdowns. Despite being considered "glitchy" by many operators, the UAN systems do have an exceptional safety record which is attributed to their very reliable fail-safe protocols.

Commercial UAN teleport operators are renowned throughout the Frontier for their ominous safety announcements. The two most common safety admonishments include "Please remain perfectly still until your teleportation has completed. This facility is not responsible for any lost or disintegrated items that may occur due to terminal pod shifting during transmission", and "Please stand clear of the terminal pod doors as items may have shifted about or been "altered" during the teleportation process".

TELEPORTATION RELAY NETWORKS

The maximum safe operational range can be safely extended by using a teleportation relay network system. This system, also called a TRN for short, is a special dedicated communications array designed to receive, amplify, and re-transmit a teleportation transmission. TRN's are most commonly found on space elevators, orbital communication satellites, space stations, and starships.

Unlike communication arrays, TRN's require special capacitors in order to relay the energy transferred by a teleportation signal. Prior to the teleportation sequence, the sending facility must run a diagnostic check on the TRN to ensure it is functioning properly. A faulty capacitor can result in a lost signal or damage to the receiving station due to the high amount of energy involved in a teleportation transmission.

FAIL SAFE PROTOCOLS

With the exception of some older model MCT devices, all licensed teleportation devices are equipped with fail safe protocols to help ensure the successful teleportation of passengers and cargo. Upon initiating the teleportation sequence any malfunction or signal disruption detected by the control system will automatically shutdown the teleport terminal.

Closed circuit teleportation networks have an additional safety feature that allows the system to recapture a lost or disrupted signal as long as the signal remains inside the network.

TRAVEL BY TELEPORTATION

The use of teleportation as a means of travel is becoming more common throughout the Frontier. However, the availability and cost of this new technology has made it difficult for the average person to have access to it. With the price of a round trip ticket on a commercial teleport network starting around 4000 credits few travelers can afford to use these services regularly.

Pan Galactic has developed the infra-structure for a less expensive public teleport transit system for major cities but these programs have stalled with cost overruns and political entanglements. Over half of the original CCN facilities built by Pan Galactic are still unfinished or were abandoned. Some of these facilities

are completely operational with terminals that have never been used.

The development of the Universal Access Network by En-Trav dramatically improved the popularity of teleportation travel but their "glitchy" nature and safety concerns have discouraged many potential travelers. Despite these problems, teleportation technology has amazing potential for the future of personal travel.

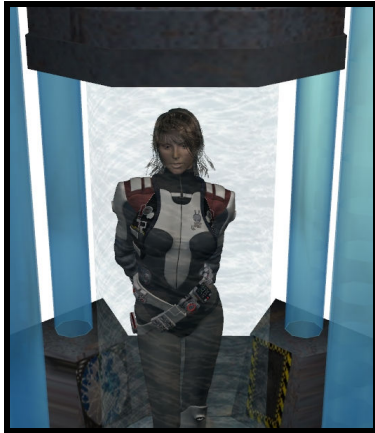

The table below provides a general baseline of passenger teleportation success rates under normal, difficult, extreme, and risky conditions. There are a lot of factors that can influence the difficulty of a teleportation such as passenger condition, environmental conditions, equipment malfunctions, or signal interference. Referees can use this table to determine the difficulty for each Character or NPC Race based on the conditions of the scenario. Roll percentile dice (d100) against the difficulty rate described below to determine if the teleport was successful.

PASSENGER TELEPORT TABLE

Subject	Ideal	Difficult	Extreme	Risk
Dralasite	90%	70%	50%	30%
Human	85%	65%	45%	25%
Yazirian	85%	65%	45%	25%
Humma	85%	65%	45%	25%
Ifshnit	85%	65%	45%	25%
Elorna	80%	60%	40%	20%
Saurian	80%	60%	40%	20%
Vrusk	75%	55%	35%	15%
Osakar	75%	55%	35%	15%
Sathar	75%	55%	35%	15%
S'sessu	75%	55%	35%	15%
Ul-Mor	70%	50%	30%	10%
Zuraqqor	65%	45%	25%	5%
Mechanon	40%	20%	0%	0%
Zethra	20%	0%	0%	0%

NPC SKILL MODIFIER TABLE

NPC Operator Skill	Modifier
Unskilled Operator	-20%
Novice Operator	-10%
Experienced Operator	0%
Expert Operator	+10%
Elite Operator	+20%

CARGO TELEPORTATION

The safest and most common use of teleportation technology is the transport of cargo. The UPF and many private corporations throughout the Frontier have embraced this new technology for rapid movement of valuable cargo. It is becoming more common to see UPF and corporate starships equipped with teleportation systems for the transport of cargo to and from planet based terminals. While the initial cost of a teleport system is very expensive it can quickly pay for itself in the reduction of conventional transportation costs.

INORGANIC CARGO TABLE

Subject	Ideal	Difficult	Extreme	Risk
Simple	90%	70%	50%	30%
Moderate	80%	60%	40%	20%
Complex	70%	50%	30%	10%

ORGANIC CARGO TABLE

Subject	Ideal	Difficult	Extreme	Risk
Simple	80%	60%	40%	20%
Moderate	70%	50%	30%	10%
Complex	60%	40%	20%	0%

NPC SKILL MODIFIER TABLE

NPC Operator Skill	Modifier
Unskilled Operator	-20%
Novice Operator	-10%
Experienced Operator	0%
Expert Operator	+10%
Elite Operator	+20%

TELEPORTATION FAILURES

Teleporting passengers and cargo is a risky endeavor even under the most ideal circumstances. Despite teleportation's high safety record, teleport failures do occur frequently and are considered especially common in commercial systems.

The three most common types of teleportation failures involve operator error, equipment malfunctions, and cargo or passenger tolerances. In most circumstances these failures are detected during the scan and diagnostic phases before the passenger or cargo begins teleportation. However, if the failure occurs during the actual teleport the results can be unpredictable and potentially disastrous.

Almost all teleportation devices include some kind of failsafe system to prevent loss of life or cargo but even these systems are not perfect.

In the event that a teleportation roll is unsuccessful Referees can use the table below to randomly generate the teleport failure or make one up on their own that fits the scenario.

RANDOM TELEPORT FAILURE TABLE

Roll	Failure	Result
01-04	Power Failure	No Teleport Possible
05-09	Computer Glitch	Wrong Destination
10-14	Scanner Failure	Delayed 1d10 Turns
15-19	Operator Error	No Teleport Possible
20-24	Targeting Failure	Wrong Destination
25-29	Diagnostic Failure	Delayed 1d10 Turns
30-34	MCT Unit Failure	No Teleport Possible
35-39	Operator Error	Delayed 1d10 Turns
40-44	Signal Hi-jacked	Wrong Destination
45-49	Transmitter Failure	No Teleport Possible
50-54	Computer Glitch	Delayed 1d10 Turns
55-59	Operator Error	Wrong Destination
60-64	Signal Jammed	No Teleport Possible
65-69	Minor Malfunction	Delayed 2d10 Turns
70-74	Signal Hi-jacked	Abduction / Theft
75-79	Receiver Failure	No Teleport Possible
80-84	Major Malfunction	Delayed 2d10 Hours
85-89	Signal Intercepted	Wrong Destination
90-94	Signal Disrupted*	Partial Teleport*
95-00	Signal Lost*	Subject / Cargo Lost

Referees are cautioned that teleport failure rolls that generate "Partial Teleport" or "Subject Lost" indicate a critical failure. These teleport failures result in the partial or complete destruction of the subject being teleported. If the partial or complete loss of the item or passenger does not fit the tone of your game session you can substitute these results for the "No Teleport Possible" result.

TELEPORTATION ILLNESS

Teleportation illness, or T.I. for short, is a common neurological disorder that afflicts teleportation travelers. Scientists from the Pan Galactic Corporation have studied the illness extensively and are not sure what the exact cause of the illness is. It is commonly believed that Teleportation Illness may be a side effect of the reintegration process. Symptoms of the illness are usually temporary and range from mild fatigue to psychotic rage.

Each time a traveler teleports they are exposed to the conditions that cause Teleportation Illness and their resistance to it is weakened. Upon each teleportation the referee should have each player conduct a percentile dice roll to see if the character contracts T.I.

Players can track their teleportation usage in the notes section of their Character Sheet. Once a traveler has exhausted their resistance to T.I. they will manifest the illness upon each teleportation. There is no cure for the illness as the process of teleportation itself causes the illness. There is no known treatment for Teleportation Illness and the only way to prevent it is to avoid using teleport devices completely.

T.I. RESISTANCE TABLE

Subject	1st	2nd	3rd	4th	5th
Mechanon	N/A	N/A	N/A	N/A	N/A
Dralasite	90%	70%	50%	30%	10%
Human	80%	60%	40%	20%	0%
Yazarian	80%	60%	40%	20%	0%
Humma	80%	60%	40%	20%	0%
Ifshnit	80%	60%	40%	20%	0%
Elorna	70%	50%	30%	10%	0%
Saurian	70%	50%	30%	10%	0%
Vrusk	70%	50%	30%	10%	0%
Osakar	70%	50%	30%	10%	0%
Sathar	60%	40%	20%	0%	0%
S'sessu	60%	40%	20%	0%	0%
Ul-Mor	60%	40%	20%	0%	0%
Zuraqqor	60%	40%	20%	0%	0%
Zethra	60%	30%	10%	0%	0%

T.I. SYMPTOM TABLE

Roll	Symptom	Duration
01-04	Mild Fatigue	1d10 Hrs.
05-09	Dizziness	1d10 Hrs.
10-14	Confusion	1d10 Hrs.
15-19	Hallucinations	1d10 Hrs.
20-24	Mild Depression	1d10 Hrs.
25-29	Memory Loss	1d10 Hrs.
30-34	Digestive Distress	1d10 Hrs.
35-39	Mild Hearing Loss	1d10 Hrs.
40-44	Mild Vision Loss	1d10 Hrs.
45-49	Euphoria	2d10 Hrs.
50-54	Severe Fatigue	2d10 Hrs.
55-59	Partial Paralysis	2d10 Hrs.
60-64	Severe Depression	2d10 Hrs.
65-69	Temporarily Blindness	2d10 Hrs.
70-74	Temporarily Deafness	2d10 Hrs.
75-79	Amnesia	3d10 Hrs.
80-84	Convulsions	3d10 Hrs.
85-89	Unconsciousness	3d10 Hrs.
90-94	Full Paralysis	3d10 Hrs.
95-00	Psychosis / Rage	3d10 Hrs.

CYBERNETIC DEVICES

Most teleportation centers will not allow passengers or animals with implanted cybernetic or prosthetic devices to be teleported. If there is a malfunction in the teleportation equipment or a disruption of the transmission the implanted device or prosthetic may become molecularly fused to the passenger during the reintegration process. Obviously the risk and type of injuries can occur vary depending on the kind of cybernetic device or prosthetic that is involved. By law, both military and commercially licensed teleport operators have the right to refuse the teleportation of any person, animal, or cargo that may pose a safety risk to themselves or someone else. Ultimately, the choice resides with the judgment of each individual operator and the willingness of the passenger.

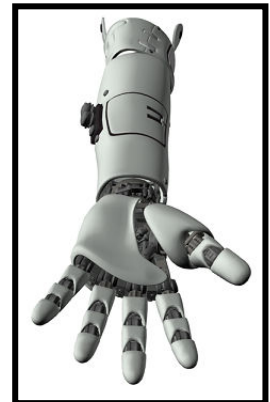

CYBERNETIC EFFECT TABLE

Roll Effect Of Teleportation

01-10	Teleport Successful, No Effect
11-20	Teleportation Illness (See Table)
21-30	Minor Malfunction Of Implant
31-40	Minor Damage To Implant
41-50	Severe Malfunction Of Implant
51-60	Severe Damage To Implant
61-70	Critical Malfunction Of Implant *
71-80	Critical Damage To Implant *
81-90	Implant Fused With Host *
91-00	Implant Fused With Teleporter *

* Indicates adverse effect of teleportation on the cybernetic device that results in injury to the passenger teleporting.

PERSONAL CARRY ON ITEMS

Teleport passengers can be teleported while carrying personal items so long as those items do not pose a safety hazard, touch the interior walls of the terminal pod, or are prohibited cargo. If any personal item touches the interior walls during the teleportation it will be instantly destroyed. For this reason all personal carry on items or cargo must fit within the terminal pods safety zone. One well known commercial teleport cargo service recently coined the popular phrase "If it fits, it transmits" to educate consumers of this important, but often overlooked, safety issue. Oversized items which do not fit within the terminal pod safety zone will not be allowed to teleport.



RESTRICTED CARGO

Most forms of matter can be teleported by a skilled operator with properly functioning equipment. However, some items are just too volatile, dangerous, or complicated to be safely teleported. All organic or inorganic items must be carefully screened and scanned by a trained technician before they can be teleported. Items which can release energy during the disintegration process or become volatile during the reintegration process are strictly prohibited by law. Any cargo that is illegal or is considered contraband is also prohibited by law from being teleported.

Depending on whether the teleportation facility is commercial, industrial or military the teleportation of weapons may be restricted or prohibited. Travelers should always check with their local Star Law or Bureau of Teleportation Transit Office for a complete listing of

teleport facility cargo restrictions. In facilities where personal or duty weapons are permitted, energy weapons must be powered down with power supplies removed prior to entering the teleportation terminal pod. To prevent volatility risk during re-integration only "teleport-safe" shielded power supplies will be allowed to be teleported. High explosive and binary propellant munitions are strictly prohibited from teleportation at any commercial or industrial terminal.

RESTRICTED CARGO TABLE

Type Of Cargo	Status	Reason
Yazarian Ale	Prohibited	Volatility
Binary Compounds	Prohibited	Volatility
Biological Viruses	Prohibited	Safety Risk
Medical Waste	Prohibited	Safety Risk
Symbiotic Organisms	Prohibited	Safety Risk
Cybernetic Devices	Restricted	Safety Risk
Medical Nanobots	Restricted	Safety Risk
Radioactive Material	Prohibited	Volatility
Hazardous Waste	Prohibited	Safety Risk
SEU Micro Disks	Restricted	Volatility
SEU Power Clips	Restricted	Volatility
SEU Power Belts	Restricted	Volatility
SEU Power Packs	Restricted	Volatility
Parabatteries	Restricted	Volatility
Atomic Fuel Pellets	Prohibited	Volatility
Plasma Fuel Cells	Prohibited	Volatility
Hydrogen Fuel Cells	Prohibited	Volatility
Helium 3 Fuel Cells	Prohibited	Volatility
Antimatter	Prohibited	Volatility
Pure Hydrogen Gas	Prohibited	Volatility
Pure Oxygen Gas	Prohibited	Volatility
Tangler Grenades	Prohibited	Volatility
Energy Weapons	Restricted	Safety Risk
Maser Weapons	Prohibited	Safety Risk
Gyrojet Ammunition	Restricted	Safety Risk
Explosive Devices	Prohibited	Volatility
Tornadium D-19	Prohibited	Volatility
Tornadium D-20	Prohibited	Volatility
Plastid	Prohibited	Volatility
Isolinium	Prohibited	Volatility
Chemical Weapons	Prohibited	Safety Risk
EMP Weapons	Prohibited	Safety Risk
Holo Screen / Suit	Prohibited	Safety Risk
Reactive Armor	Prohibited	Safety Risk

Presented above is a sample list of items which are commonly restricted or prohibited for teleportation. Referees should keep in mind that any item that could become volatile or present a safety hazard during teleportation should be considered restricted or prohibited. This also includes any item which could generate any kind of energy that may disrupt the teleportation transmission.

STARSHIP TELEPORTATIONS

One of the most common places to find a teleportation device is on a starship or space station. Teleportation is particularly useful for space faring vessels as it dramatically reduces the costly use of system ships and shuttles for transporting personnel or cargo. There are three primary types of teleportation involving starships which include Ship to Surface, Ship to Ship, and Relay.

1. SHIP TO SURFACE TELEPORTATION

Ship to surface teleportation is the most widely used application of teleportation technology in the Frontier. This type of teleportation includes any transport of personnel or cargo via teleportation to or from a terminal on the surface of a planet.

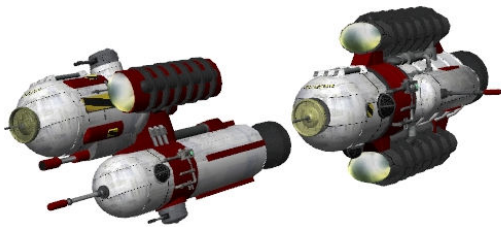

2. SHIP TO SHIP TELEPORTATION

Ship to Ship teleports are commonly referred to by the term "Teleport Docking Maneuver" or TDM. Even though no actual physical contact occurs between the ships, the TDM is still considered a "docking" maneuver because both ships have to be travelling at the same speed, in the same direction, and maintain proper teleport range. A TDM is a tricky endeavor that requires the coordinated efforts of the pilot, navigator, and teleport operator of both of the vessels involved. The real challenge in attempting a TDM is not so much the teleport as it is keeping both ships in sync with each other long enough to complete the teleport. The general rules for conducting a TDM in orbit or in flight are as follows:

- » Both starships must be equipped with a teleportation system.
- » The ships must be in adjacent hexes no more than 10,000km apart unless a relay network is used.
- » The ships must be travelling at the same speed and in the same direction to maintain teleport range.
- » The ships cannot teleport while in the void or travelling at FTL.
- » The ship's screens or energy shields must be deactivated during the teleport to prevent signal disruption.
- » Teleportation cannot occur in an area where an EMP weapon has been deployed.
- » Teleportation must be from terminal to terminal and the person or cargo being teleported must be able to fit in the terminal. For example, if a large item is being teleported from a large terminal to a small terminal the teleport will not be possible. However, small terminals can teleport to a larger one without any restriction.

- » Both ships must have sufficient space and energy resources to mount a teleport system

When attempting a TDM the referee should conduct a skill check on the pilot, navigator, and teleport operator of each ship. If any of these skill checks fail the teleport will not be possible. Players can attempt another TDM in 1d10 turns as long as the starships remain in sync. If the skill checks are successful for establishing the TDM, then the referee can use the normal passenger or cargo teleportation success or failure tables as normal to determine the outcome of the actual teleport.

3. RELAY TELEPORTATION

Starships, space stations, and satellites are often used as relay points for teleport destinations that are out of range or difficult to reach. Sometimes starships which are unable to establish a standard Teleport Docking Maneuver will use a relay network on another ship or space station in order to complete the teleport. Ground based teleport operators will frequently rent "air time" on a space station or starship's TRN to reach teleport terminals that are blocked by ground interference. In order for a starship to be used as a relay point it must be in orbit with the planet or space station where the sending terminal is located. Starships in flight cannot be used as a relay point unless they have established a TDM with the ships that are sending and receiving the teleport transmission.

TRN AIRTIME RENTAL RATES

Subject	Per Teleport	Per Month
Cargo	250 Credits	1000 Credits
Passenger	500 Credits	2000 Credits
Mixed*	750 Credits	2500 Credits

* Mixed – Cargo and Passenger(s)

TELEPORT DETECTION

Teleportation transmissions require a large amount of power and emit a unique energy signature that is detectable by any sensor system that is calibrated to do so. Anyone with Teleport operator skill or technician skill can easily calibrate a sensor system to detect teleportation transmissions. All teleport terminals have the ability to detect and track any teleportation occurring within the maximum operating range of the terminal.

Characters or NPC's with a Teleport operator skill will be able to use any teleport terminal to detect or track any teleport transmissions within range. Once detected, the teleport operator can determine where the signal is coming from, what type of item was being teleported, and what terminal the signal was sent to.

Some terminals are equipped with the ability to encrypt this information so that it cannot be read but the data is always present imbedded in the signal. Characters or NPC's with an espionage skill can attempt a skill check to see if they can decipher the encrypted data.

H.A.L.O. TELEPORT SYSTEMS

Hazardous Area Landing Operation or H.A.L.O. System is a one-way special operations troop teleportation system designed for the UPF Space Fleet by the Pan Galactic Corporation. The HALO system uses a standard starship mounted teleportation system to teleport troops to a special ground based receiving terminal called a HALO Pod. The HALO Pod is delivered to the landing zone either via planetary probe, unmanned landing craft, or dropship.

The most common configuration delivering the HALO Pod is by a specially modified planetary probe launched from an orbiting starship. Once the HALO Pod has been deployed on the planet surface the starship can then teleport troops to the HALO Pod.

This one-way only teleport terminal is designed to be used in combat operations where conventional dropship or shuttle landings are too hazardous. HALO Pods come equipped with a self contained power source that is capable of receiving up to 10 teleport transmissions before it is depleted. The Halo Pod is only large enough to accommodate one passenger or small cargo item at a time.

The system, affectionately called the "Special Delivery Express", can only receive a teleportation transmission and is not capable of returning passengers back to the Starship. Once troops have been deployed via HALO teleport they will have to exfiltrate to a safe landing zone for conventional shuttle or dropship pick up. HALO Systems cannot be purchased by civilians and are extremely rare items.

HALO System teleport transmissions are always encrypted military signals. Like any other teleportation signal they can be detected and tracked by a sensor system that is calibrated to do so. However, the contents of the transmission will be un-discernable unless the sensor operator is able to decipher the encryption. HALO System transmissions cannot be hijacked due to their unique nature but can be jammed preventing the teleport from occurring. HALO Systems are not able to operate in an area where an EMP weapon has been deployed.

REGULATION & ENFORCEMENT

Teleportation travel is regulated by a special division of Star Law called the Bureau of Teleport Transit or BTT for short. The BTT is primarily a regulatory agency that is responsible for the licensing administration of teleportation operators and equipment. Additionally, the BTT is also responsible for investigating any accidents or criminal activity associated with teleportation travel which is accomplished through BTT field agents.

As one of the newest, and smallest, divisions of Star Law it is not uncommon for BTT agents to be assigned to joint operations with other law enforcement

agencies, planetary militias, or UPF military forces. These operatives enjoy some of the broadest jurisdictional authority of any law enforcement agency in the Frontier but are often required to work for long periods of time in the field without support.



TELEPORT OPERATOR SKILLS

Teleport Operators go through extensive training to learn how to safely operate a teleportation system. An Operators skill set falls under the Technological PSA and includes several sub skills that are essential to the operation of any teleportation system.

System Operation

Success Rate: + Skill Level x10%

This essential skill allows an Operator to properly use any standard teleportation system. Before an operator can attempt to teleport a passenger or cargo they must learn this skill.

Target Acquisition

Success Rate: + Skill Level x 10%

This skill improves an Operators ability to locate and target a receiving terminal that is beyond line of sight or moving.

Troubleshoot

Success Rate: 100%

This skill allows an expert Operator to identify and troubleshoot minor problems with any standard teleport system.

Asses Security

Success Rate: 60% + Skill Level x 10%

This skill allows an Operator to recognize security and safety issues on any teleportation system. This skill also allows the operator the ability to successfully navigate the security system of any standard teleportation system.

Repair Equipment

Success Rate: 30% + Skill Level x 10%

This skill allows an Operator the ability to recognize and repair minor malfunctions in any standard teleportation system.

Signal Tracking

Success Rate: 40% + Skill Level x 10%

This skill allows an Operator the ability to detect, identify, locate, and track any teleportation signal within operating range. This skill also allows the operator to discern differences in transmission signals to determine what kind of item is being teleported.

Signal Recall

Success Rate: 20% + Skill Level x 10%

This skill allows an Operator the ability to recall and capture a lost or disrupted signal in a closed circuit network. An expert Operator only has a one hour window in which to conduct a signal recall once a signal becomes lost inside the network. Typically, a signal recall attempt takes 5d10 minutes. If the operator fails the skill check they can make a second attempt if time allows. If the operator fails the second attempt the signal will become so weak and corrupted that it will not be able to be re-integrated.

Bypass Security

Success Rate: 30% + Skill Level x 10%

This skill allows an Operator the ability to Bypass security systems used on any standard teleportation system.

Network Interfacing

Success Rate: 50% + Skill Level x 10%

This skill improves the Operators ability to locate and operate a Teleportation Relay Network.

Disable Fail Safe Protocol

Success Rate: 20% + Skill Level x 10%

This skill allows an Operator to disable the Fail-Safe Protocols on any standard teleportation system to permit the teleportation of cybernetic devices and potentially dangerous cargo. This skill also allows the

operator to bypass the safety protocols and allow a teleportation system to conduct risk teleportations.

TDM Coordinator

Success Rate 40% + Skill Level x 10%

This specialty skill improves a Teleport Operator's ability to coordinate a ship's crew to successfully complete a teleport docking maneuver. Teleport experts who learn this skill will be able to complete a TDM upon a successful skill check roll without the any additional starship crew skill checks.

Modify Equipment

Success Rate 30% + Skill Level x 10%

This skill allows an expert teleport operator the ability to modify teleportation equipment for specific tasks it was not originally intended for such as signal jamming and hi-jacking.

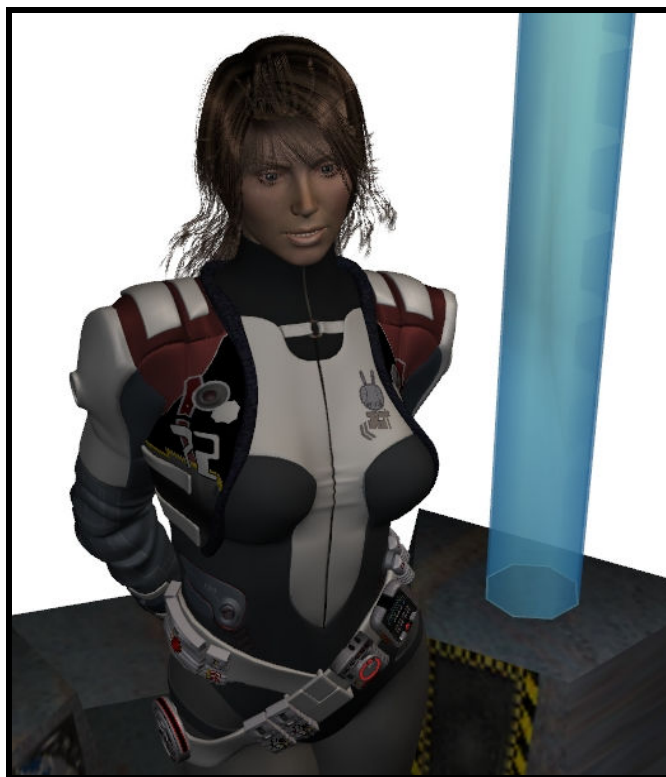

CRIMINAL ACTIVITY

Since the public introduction of teleportation criminals have sought to exploit this technology for their own illegal enterprises. As teleportation continues to become more accessible throughout the Frontier the number of reported crimes associated with it has grown dramatically. Three types of crime in particular: smuggling, hi-jacking, and fugitive evasion, have become particularly troublesome for teleport operators and travelers.

The most common criminal activities associated with teleportation technology is smuggling. Industrial sectors throughout the Frontier have been plagued with teleport smuggling since the technology first became available. The most frequently reported method of smuggling is the transport of contraband concealed inside industrial cargo. Since industrial terminals are the least regulated in the industry, and at times the most dangerous, smugglers have found this to be the ideal environment to apply their trade. Smuggling in the Commercial teleport sector is still relatively rare due its highly visible nature and strict safety protocols. However, the BTT have found that as popularity of commercial teleportation grows so does the appetite of criminals who wish to exploit it.

The most disturbing and potentially dangerous criminal activity associated with teleportation involves the hijacking of teleport transmissions for the purpose of stealing cargo or abducting passengers. Pirates usually accomplish this by using a modified TRN unit to intercept an outbound teleport while it is en-route to its destination. Pirates are particularly fond of snatch and grab operations near space stations as they can easily intercept the inbound transmission from their spacecraft in a lower orbit.

While the hi-jacking of cargo is preferred, some Pirates and criminal organizations have been known to abduct travelers as well. This crime is particularly disturbing because the hijackers are usually long gone before authorities can determine what caused the transmission to be lost. In some cases the abductees were believed to have been killed when the signal was lost when in fact they had been kidnapped.

Signal hi-jacking is an extremely difficult task that the referee should resolve as a teleport docking maneuver requiring a modified TRN device. Characters or NPC's with a moderate to high technician skill can complete the necessary modifications to a TRN to make it hi-jack capable. Failure to complete the teleport docking maneuver will cause the hi-jacking attempt to fail and the teleport signal will continue to its original destination. Any failed attempt to hi-jack a teleport signal will immediately reveal the presence of the modified TRN on the hi-jacker's spacecraft.

The newest and fastest growing crime involving the use of teleportation technology is fugitive evasion. Unlike smuggling and Hi-jacking which have been present since the technology was invented, fugitive flight via teleportation is a relatively new crime. The Industrial and corporate sectors were the first sectors to be

exploited by fugitives. However, bolder and more desperate criminals have been increasingly turning to commercial teleportation facilities as a means of escape.

Commercial teleport operators are highly trained to recognize fake ID cards, holo-screens, disguises, and appearance alterations in order to prevent criminals from using teleportation as a means of escape from the law. However, occasionally a fugitive on the run does manage to slip through or bypass security.

Fugitives with the right connections sometimes can circumvent teleport security by using a privately owned industrial or corporate teleport terminal. However, doing so can only buy time for the fugitive as all terminal control computers are programmed to automatically report any flagged passengers or cargo to the BTT. As soon as the fugitive is scanned for teleportation his or her composition data is checked against the Star Law database criminal data base and any matches activates the automated notification system.



**POMM'S
BODY**

Make other bodies jealous

POMM'S
Dral
silk

NEW POMM'S
Dral Silk
BODY LOTION

**MORE BEAUTIFUL
ALL OVER**

Uncover both younger and
healthier looking skin
everywhere

POMM'S
INSTITUTE

CLASSIFIEDS

Try **New Vrug Butter**
The Amazing New Cure for
Late Onset Calcification In
Geriatric Vrusk!

(Buy one get one free with this coupon)

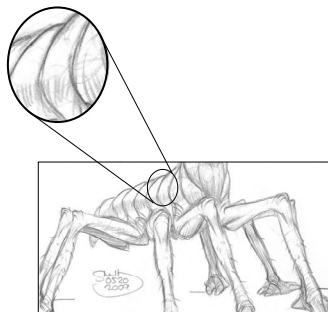

Rim Star Cruises

A Trans Travel subsidiary

Presents a 56 Light Year Pleasure Cruise
with layovers in Zebulon, Capella, Osak,
and Cryzia

See the Famous Showrooms of Faire, the
Vulturnian Fire Crystals
& other exotic location in the Rim

First class tickets begin at 9,000 Cr
Journey class tickets at 4,000 Cr

At prices this low tickets won't last!

Book Today

Chronocom Subspace Relay#

GHDH83y3j383373

YAZIRIANS

Do suffer from
Chronic Dissociative Rage Syndrome?



Contact:

**The Kazzack Clinic for Physcho-Social
Disorders**

Com relay: GF894567833

Timeon Safari

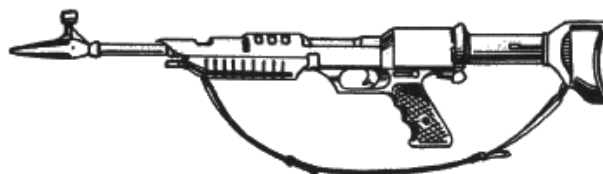

The adventure of a lifetime!

Do you dream of the hunt? Do you want to experience the thrill of the hunt? Come to Lossend!

Timeon Safari is the Frontier leader in Big Game Hunting Expeditions. Only Lossend offers seven native trophy class animals on the Frontier Game Association approved list. No other planet in the Frontier can offer the depth and variety of managed game for the avid hunter.

Timeon Safari offers licensed big game expeditions for:

Losso Planes Maiff	1,000Cr
Higrax Delver	2,500Cr
Goalbeast	5,000Cr
Slackwaltzer	5,000Cr
Sail Cliff Stalker	9,000Cr
Aragill	15,000Cr
Lossodragon	20,000Cr

All expeditions guided by our expert hunters and native trackers. Kill opportunity for your license guaranteed! Yazirian clan rates available.

Timeon Safari LLC
#30 Sail Cliff Beach Resorts
Ataraxis Cove, Lossend
Chronocom #3572244505000

Table of Contents		
Ranged Weapons -----		1-4
	Beam Weapons	1
	Projectile Weapons	1
	Gyrojet Weapons	2
	Grenades	3
	Automated Weapons	3
	Mounted/Vehicle Weapons	3
Melee Weapons -----		5
	Archaic Weapons	5
	Melee Weapons	5
Defenses and Ammunition -----		6-7
	Ammunition	6
	Defense Suits and Screens	7
	Armor	7
Equipment -----		8-10
	Miscellaneous Equipment	8
	Biogenic Equipment	9
	Toolkits	9
	Parabatteries and Generators	9
	Weapon Accessories	9
	Prothetics	10
	Bionic Implants	10
	Cybernetic Implants	10
Robots and Computers -----		11-13
	Robot Costs	11
	Computers	12
	Robot Designs	13-15
Vehicles and Transport -----		16-18
	Standard Vehicles	16
	Vehicle Modifications	17
	Vehicle Accessories	18
	Travel Costs	18
Spaceships -----		19-20
Space-faring Races -----		21-26
Planets -----		27-38
	General Details	27-30
	Atmosphere/Climate	31-34
	Notes	34-38
PSA Skills -----		39-40

Ranged Weapons

Weapons	Cost (Cr)	Wgt (kg)	Damage	Ammo®	SEU	Rate	Defense	Range (PB/S/M/L/E)	Source
Beam Weapons									
Light Stunner Pistol	150	0.5	Stun	SEU	4	1	Gauss/A-S	5/10/-/-/-	#1-p1
Blastpistol	200	1.5	4d10	SEU	2	1	Gauss/A-S	5/15/-/-/-	#1-p1
K-Pulse Pistol	250	2	3d10	SEU	2	3	Inertia	5/10/20/40/80	#4-p19
Tizzle Lazer ²	300+	--	1d10/5d10	20 SEU	1 or 5	2	Albedo	3/8/15/--/--	#7-p23
MagstarF8 ****	400	1.5	1d10 per SEU	SEU	1-4	2	Albedo	5/20/50/100/200	#13-p6
Evran	450	1	1d10-1 per SEU	SEU	1-10	2	Albedo	5/20/50/100/200	#13-p6
Electrostriker	500	1	5	SEU	2	1	Gauss/A-S	5/15/-/-/-	AD
Microstriker	500	1	5 SEU	5 SEU	2	1	Albedo	5/15/-/-/-	#7-p9
Sonic Stunner	500	1	5	SEU	2	1	Sonic/A-S	3/10/20/30/50	AD
Laser Pistol	600	1	1d10 per SEU	SEU	1-10	2	Albedo	5/20/50/100/200	AD
LE-1000	600	.5	1d10-2 per SEU	20 SEU	1-10	2	Albedo	5/20/50/100/200	#13-p6
K'raktan	600	1	1d10 per SEU	SEU	1-10	2	Albedo	5/20/50/100/200	#13-p6
Sonic Disruptor	700	4	6d10/4d10/2d10/1d10	SEU	4	1	Sonic	2/10/20/40/-/-	AD
SP-4507 Balor Revolver	600	2				3	Inertia		#15-p73
- projectile			1d10+3	7	--			5/15/35/65/160	#15-p73
- Gyrojet			3d10	1	--			-/5/60/120/200	#15-p73
Flamethrower Gauntlets	700	2	3d10 (4d10)	10 bursts (each)	--	1	Inertia	5/10/20/30/50	#14-p36
KTX-40 Laser Pistol	700	1	1d10/SEU	2 SEU clips	1-5	3	Albedo	5/15/40/75/150	#15-p73
WarTech SE-9 LWS - Pistol Mode	700	2	1d10 per SEU	20 SEU	1-10	2	Albedo	5/20/50/100/200	#14-p36
- Rifle Mode	700	5	1d10 per SEU	60 SEU (3 SEU clips)	1-20	2	Albedo	10/50/100/200/400	#14-p36
Laser Auto Rifle	750	3	1d10 (5d10)	SEU	1 (10)	3 (1)	Albedo	5/15/30/60/150	#7-p23
LE-1500	750	1	1d10+2 per SEU	SEU	1-10	2	Albedo	5/20/50/100/200	#13-p6
Laser Rifle	800	3	11-13	SEU	1-20	2	Albedo	10/40/100/200/400	AD
Heavy Laser Pistol	1,500	2		20 SEU x2					
- stun mode			stun		2 SEU	1	Gauss/A-S	3/10/20/30/50	
- laser mode			13-15		5/10 SEU	2	Albedo	5/20/50/100/200	
- plasma bolt			16-18		10 SEU	1	Albedo	3/10/20/30/50	
Laser Sniper Rifle	1,500	5	16	SEU	1-20	1	Albedo	20/100/500/1km/2km	#8-p49
Gauss Assault Rifle	1,500	4	17	100 shot/SEU	1/shot	3 (1)	Inertia	10/40/100/300/600	#8-p52
Gauss Sniper Rifle	2,000	5	18	10 shot/SEU	1/shot	1	Inertia	-/70/200/500/1000	#8-p52
Flamethrower	3,000	5		18 10 blasts (napalm)	--	1	None	10/20/30/45/70	#3-p1
Sonic Devastator**	5,000	15	19-20	SEU	10	1	Sonic	5/25/50/100/-	AD
Heavy Laser**	6,000	20	21-26	SEU	5-20	1	Albedo	-/100/500/1km/2km	AD
			27-38						
			27-30						
Projectile Weapons									
Single-barrel Shotgun (break away)	100	1	31-34	1 shell	--	1	Inertia	5/10/50/90/-	#9-p27
- Buckshot			34-38		--			+20 PB, +10 S, +5 M	#9-p27
- Sabot Slug			39-40		--				#9-p27
- Explosive Sabot Slug			6d10		--				#9-p27
Single-barrel Shotgun (sawed off)	100	1	By shell type	1 shell	--	1	Inertia	2/5/10/20/--	#9-p27
Double-barrel Shotgun	150	1	By shell type	2 shells	--	1	Inertia	2/5/10/20/-	#9-p27
Semiautomatic Pistol	150	1.5	1d10	20 rounds	--	3	Inertia	5/15/30/60/150	#1-p2
Automatic Pistol	200	2	1d10 (5d10)	20 rounds	--	3(1)	Inertia	5/15/30/60/150	AD
Needler Pistol	200	1	2d10/1d10+Sleep	10 shots	--	3	Inertia	5/10/20/40/100	AD
Pump Action Scattergun	200	3	2d10	5 shots	--	2	Inertia	5/15/40/75/150	#4-p17

Ranged Weapons

Weapons	Cost (Cr)	Wgt (kg)	Damage	Ammo®	SEU	Rate	Defense	Range (PB/S/M/L/E)	Source
Pump-Action Shotgun	200	1	By shell type	5 shells	--	1	Inertia	6/12/60/100/-	#9-p27
TAC Pump-Action Shotgun	200	1	By shell type	5 shells	--	1	Inertia	5/10/40/80/-	#9-p27
Gel Airgun	250	1		10 Gel rounds	--	2	Inertia		#7-p23
- Acid gel			3d10		--				#7-p23
- Practigel			stain/mark		--				#7-p23
- Dozezel			Sleep		--				#7-p23
- Toxin Gel			S5/T10		--				#7-p23
Tangler Gun	250	2	entanglement	10 rounds	1/clip	3, 1	RS check	5/10/20/40/80	#5-p2
Automatic Rifle	300	4	1d10 (5d10)	20 rounds	--	3(1)	Inertia	10/40/100/150/300	AD
Combat Shotgun	300	2	By shell type	8, 12, or 20 shell mag.	--	2	Inertia	5/10/40/80/-	#9-p27
Needler Rifle	400	3	3d10/1d10+Sleep	10 shots	--	3	Inertia	10/20/40/75/150	AD
Autoloading Scattergun	400	4	2d10	10 round shotgun	--	3	Inertia	5/15/40/75/150	#4-p17
Sector 6 Smallarm ²	400	1	4d10	1	--	1	Inertia	5/10/20/30/40	#6-p26
Net Gun	450	5.75	1d10 + net type	1	-	1/2	RS check	-/4/15/25/35	#13-p8
-Det-Net	500		4d10 (inertia) + 2d10 (fire)	--	--	--	Inertia/Albedo	--	#13-p8
-Mag-Net	100		entanglement	--	--	--	STR -25	--	#13-p8
-Tase-Net	200		3d10	--	--	--	Gause, STA check	--	#13-p8
MR-17 Heavy Assault Rifle	480	5.0	1d10+1 (5d10+5)	20 rounds	--	3(1)	Inertia	10/40/100/150/300	#2-p15
Electro-Magnetic Signal Stunner	500	2	special	4 EMS Shells	--	1	Inertia	-/5/50/100/150	#7-p23
War-monger Shotgun	500	4	By shell type	12 or 20 shell mag.	--	3	Inertia	10/20/50/100	#9-p27
Assault Scattergun	600	5	2d10 (5d10)	10 round shotgun (2 bursts)	--	3 (1)	Inertia	5/15/40/75/150	#4-p17
Boon Sheh Multipistol ²	700		2d10 (8d10)/as auto P/R	20 rounds/ as auto P/R	--	3 (1)	Inertia	10/40/100/150/300	#3-p30
CKA Hi-Ler Hunting Rifle***	700	4.0	2d10	20 rounds	--	1	Inertia	10/70/200/500/1km	#2-p15
Semi-Automatic Sniper Rifle	1,200	5	1d10*	20 rounds	--	3	Inertia	20/100/250/500/1km	#4-p17
Pulse Rifle	1,800	5	--	99 rounds (PulseClip)	--	--	--	--	#5-p16
-Semiautomatic Mode	--	--	1d10+1	1 round	--	3	Inertia	10/40/100/150/300	#5-p16
-Burst Fire Mode	--	--	3d10+3	4 rounds	--	2	Inertia	10/40/100/150/300	#5-p16
-Full Auto Mode	--	--	5d10+5	10 rounds	--	1	Inertia	10/40/100/150/300	#5-p16
-Pump-Action Grenade Launcher	--	--	8d10	4 cartridge grenades	--	1	Inertia	--/25/50/100/200	#5-p16
Machine Gun**	2,000	20	10d10	10 bursts	--	1	Inertia	-/70/200/500/1km	AD
Recoilless Rifle**	4,000	20	12d10	1 shell	--	½	Inertia	-/150/1km/2km/3km	AD
GyrojetWeapons									
Gyrojet Wrist Rockets ²	125	1.5	2d10	3 rounds each	--	3	Inertia	-/5/25/50/100	#1-p2
Gyrojet Pistol	200	1	2d10	10 rounds	--	3	Inertia	-/5/50/100/150	AD
WarTech GC-6 Gyrojet Carbine	250	3.5	2d10	5 rounds	-	3	Inertia	-/5/50/75/125	#14-p36
Gyrojet Rifle	300	4	3d10	10 rounds	--	3	Inertia	-/5/75/150/300	AD
WarTech GAR-10 Gyrojet Assault Rifle	400	5.5	3d10 (8d10)	20 rounds (4 bursts)	-	3 (1)	Inertia	-/5/75/150/300	#14-p36
Grenade Rifle	700	4	Asgrenade	1 bullet	--	½	RS check	-/25/50/100/200	AD
WarTech PGR-2 Marksman GJ Rifle*	1,500	5.5	3d10	5 rounds	-	1	Inertia	-/70/200/500/1km	#14-p36
Grenade Mortar	2,000	15	Asgrenade	1 shell	--	½	RS check	-/200/500/1km/2km	AD
Heavy Gyrojet Rifle	2,000	5.5	8d10 impact/6d10 area	10 Heavy Gyrojet Rounds	-	2	Inertia	-/5/75/150/500 (700)	#10-p14
WarTech HGR-9 Heavy Gyrojet Rifle**	2,000	12	10d10	5 rounds	-	1	Inertia	-/5/60/125/200	#14-p36
Rocket Launcher	5,000	15	15d10	1 rocket	--	½	Inertia	-/70/200/500/1km	AD
WarTech GIMG-12 GJ Machine Gun**	7,000	25	15d10	5 bursts (100 rounds)	-	1	Inertia	-/5/75/150/300	#14-p36
Yazirian Triple Barrel Gyrojet	8,000	11	2d10 (9d10)	30 (3 clips of 10)/20 SEU	1/5 shots	3 (1)	Inertia	-/5/75/150/300	#12-p48

Ranged Weapons

Weapons	Cost (Cr)	Wgt (kg)	Damage	Ammo®	SEU	Rate	Defense	Range (PB/S/M/L/E)	Source
Grenades									
Doze Grenade	10	--	Sleep	--	--	1	STA check	5/10/15/25/50	AD
Smoke Grenade	10	--	-10 to Hit	--	--	1	IR	5/10/15/25/50	AD
Frag. Grenade	20	--	8d10	--	--	1	RS check	5/10/15/25/50	AD
Incendiary Grenade	20	--	4d10+1d10x3Turns	--	--	1	RS check	5/10/15/25/50	AD
Tangler Grenade	25	--	Entanglement	--	--	1	RS check	5/10/15/25/50	AD
Yazirian Disc-Grenade	25	--	8d10, 3m radius	--	--	1	Inertia	5/15/25/50/75	#5-p16
Poison Grenade	30	--	S5/T10Poison	--	--	1	STA check	5/10/15/25/50	AD
Laser Grenade, 5 SEU	35	-	5d10	1	--	1	RS/Albedo	5/10/15/25/50	#10-p14
Albedo grenade	50	-	-10 to hit, 6 meters, ¼ laser damage	1	--	1	1d10 rounds	5/10/15/25/50	#10-p14
Laser Grenade, 10 SEU	55	-	10d10	1	--	1	RS/Albedo	5/10/15/25/50	#10-p14
Stun Grenade	75	--	Stun	1	--	1	STA check	5/10/15/25/50	#7-p23
Automated Weapons									
Sentry Guns**									
- Heavy Laser	12,000	35	10d10	Type 1 Parabattery (500)	10	4	Albedo	30/-/-/-	#5-p16
- Machine Gun	7,000	25	10d10	500 Rounds (50 bursts)	10 rounds	4	Inertia	30/-/-/-	#5-p16
- Grenade Launcher	5,000	20	by grenade	25 Grenade Capsule	1	4	Inertia	30/-/-/-	#5-p16
Mounted/Vehicle/Battle Suit Weapons**									
Automatic Recoiless Rifle**									
Machine Gun**	4,800	30 kg	12d10	600 Rounds (60 bursts)	--	1	inertia	-/150m/1km/2km/3km	#9-p16
MG Autoloader/Belt	2,800	20 kg	10d10	holds 600 rounds	--	--	--	-/70m/200m/500m/1km	#9-p16
Guided Missile Pack**	10,000	30 kg	15d10	4-6	--	3	inertia	-/70m/200m/500m/1km	#9-p16
Mortar Pack**	4,000	30 kg	as grenade	4-6	--	3	per grenade	-/200m/500m/1km/2km	#9-p16
"Stinger" Gyrojet Pack**	3,000	20 kg	3d10	80	--	5-20	inertia	-/5m/50m/100m/150m	#9-p16
Machine Gun**									
Small	2,000		10d10	100 rounds (10 bursts)	--	1	Inertia	70	#15-p24
Medium	3,000		15d10	200 rounds (20 bursts)	--	1	Inertia	150	#15-p24
Large	4,000		2d10x10	300 rounds (30 bursts)	--	1	Inertia	200	#15-p24
Cannon**									
Small	4,000		12d10	Shell	--	1	Inertia	150	#15-p24
Medium	6,000		2d10x10	15 shells	--	1	Inertia	300	#15-p24
Large	10,000		4d10x10	10 shells	--	1	Inertia	600	#15-p24
Laser Cannon **									
Small	6,000		2d10x10	SEU Drum	20	1	Albedo	200	#15-p24
Medium	9,000		4d10x10	1000 SEU	40	1	Albedo	500	#15-p24
Large	12,000		6d10x10	1000 SEU	60	1	Albedo	1000	#15-p24
Autolaser **									
Small	3,000		10d10	SEU Drum	20/burst	1	Albedo	50	#15-p24
Sonic Cannon **									
Small	1,200		10d10	SEU Drum	10	1	Sonic	20	#15-p24
Medium	3,000		2d10x10	1000 SEU	20	1	Sonic	40	#15-p24
Large	6,000		3d10x10	1000 SEU	30	1	Sonic	60	#15-p24
Rocket Cluster **									
				Rocket					#15-p24

Ranged Weapons

Weapons	Cost (Cr)	Wgt (kg)	Damage	Ammo®	SEU	Rate	Defense	Range (PB/S/M/L/E)	Source
Small	5,000	15d10	15d10	12 rockets	--	1-12	Inertia	100	#15-p24
Medium	7,000	3d10x10	3d10x10	6 rockets	--	1-6	Inertia	100	#15-p24
Large	10,000	4d10x10	4d10x10	3 rockets	--	1-3	Inertia	100	#15-p24
Missile Cluster **				Missile					#15-p24
Small	7,000	15d10	15d10	12 missiles	--	1-12	Inertia	400	#15-p24
Medium	10,000	3d10x10	3d10x10	6 missiles	--	1-6	Inertia	800	#15-p24
Large	15,000	4d10x10	4d10x10	3 missiles	--	1-3	Inertia	1600	#15-p24
Bomb **				Bomb					#15-p24
Small	100	2d10x10	2d10x10	10 bombs	--	1-10	Inertia	n/a	#15-p24
Medium	500	4d10x10	4d10x10	5 bombs	--	1-5	Inertia	n/a	#15-p24
Flamethrower **				Napalm					#15-p24
Small	200	2d10	2d10	20 blasts (napalm)	--	1	none	20	#15-p24
Medium	450	4d10	4d10	10 blasts (napalm)	--	1	none	30	#15-p24
Sonic Devastator**	5,000	15	20d10/15d10/10d10/5d10	SEU	10	1	Sonic	5/25/50/100/-	AD
Heavy Laser**	6,000	20	1d10 per SEU	SEU	5-20	1	Albedo	-/100/500/1km/2km	AD
Machine Gun**	2,000	20	10d10	10 bursts	--	1	Inertia	-/70/200/500/1km	AD
Recoilless Rifle **	4,000	20	12d10	1 shell	--	½	Inertia	-/150/1km/2km/3km	AD
WarTech HGR-9 Heavy Gyrojet Rifle**	2,000	12	10d10	5 rounds	--	1	Inertia	-/5/60/125/200	#14-p36
Rocket Launcher	5,000	15	15d10	1 rocket	--	½	Inertia	-/70/200/500/1km	AD
WarTech GJMG-12 GJ Machine Gun**	7,000	25	15d10	5 bursts (100 rounds)	--	1	Inertia	-/5/75/150/300	#14-p36

* Characters of Military PSA may add their appropriate Weapons skill level x10 to the damage rolled if they take 2 full turns aiming or Weapon Skill x5 if they take one full turn aiming.

** Must be mounted (vehicle, tri-pod or Battle Suit)

*** +10 to hit when set on a solid surface. Use range category one step better.

**** Weapon jams/fails on an attack roll of 100 instead of 96-100 like normal.

® "SEU" means any source of SEU can be used (clip, belt pack or backpack). "20 SEU" means only energy clips can be used. "Power Pack" means only belt or back packs can be used.

‡ Might be difficult to find or even illegal to purchase/possess.

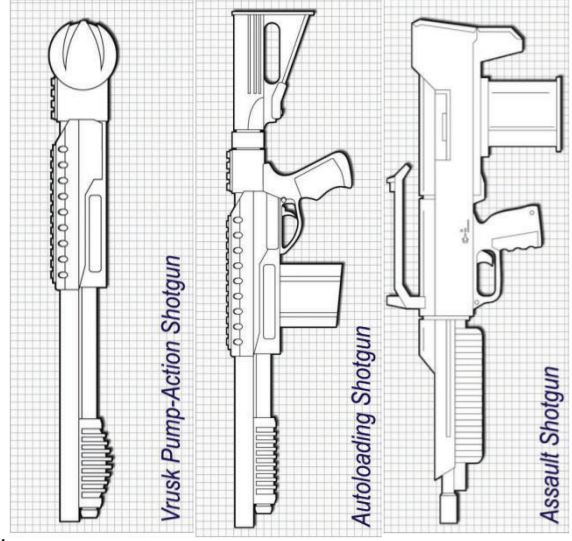
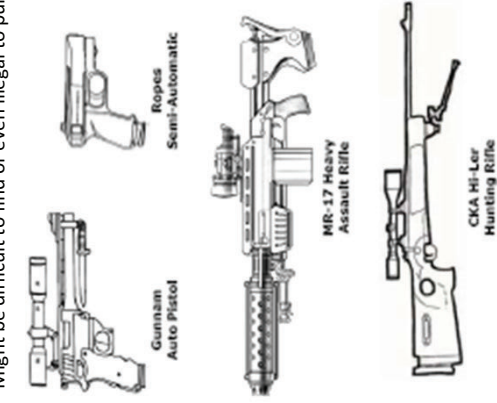

Melee Weapons

Weapons	Cost (Cr)	Wgt (kg)	Damage	Ammo®	SEU	Rate	Defense	Range (PB/S/M/L/E)	Melee (mod)	Source
Archaic Weapons										
Axe	15	1	2d10	--	--	1	Inertia	5/10/15/20/25	+5	AD
Bow	50	--	1d10	1 arrow	--	1	Inertia	510/30/75/150/300	--	AD
Knife	10	--	1d10	--	--	1	Inertia	5/10/15/20/25	+5	AD
Musket	100	2	1d10	1 shot	--	1	Inertia	5/15/40/70/100	--	AD
Spear	20	1	2d10	--	--	1	Inertia	5/10/20/30/40	+15	AD
Zamira	spec		2d10 (1d10 non-lethal)	1	--	1	Inertia	5/10/20/30/40		#3-p20
Weren Rifled Musket ²	300	3		5 1 shot (double powder)	--	1	Inertia	5/20/50/80/120		#7-p11
Weren War Pistol ²	200	1		5 1 shot (double powder)	--	1	Inertia	5/15/40/70/100		#7-p11
Weren Pepperbox ²	450	2		5 1 blast (x7 powder & shot)	--	1/3	Inertia	5/10/20/30/40		#7-p11
Melee Weapons										
Brass Knuckles	10	1	1d10	--	--	--	Inertia	--	--	AD
Electric Sword	150	2	4d10/Stun	SEU	2/hit	--	Gauss/A-S	--	+10	AD
Nightstick	20	1	2d10	--	--	--	Inertia	--	+5	AD
Polearm	40	4	4d10	--	--	--	Inertia	--	-10	AD
Shock Gloves	50	1	2d10	Powerpack	2/hit	--	Gauss/A-S	--	--	AD
Sonic Knife	50	1	3d10	SEU	1/hit	--	Sonic	--	+10	AD
Sonic Sword	300	1	5d10	SEU	2/hit	--	Sonic	--	+15	AD
Stunstick	75	1	3d10/Stun	SEU	2/hit	--	Gauss/A-S	--	+5	AD
Sword	30	2	3d10	--	--	--	Inertia	--	+10	AD
Vibroknife	25	1	2d10	SEU	1/hit	--	Inertia	--	+5	AD
Whip	20	1	1d10	--	--	--	Inertia	--	-5	AD
Blasthammer	300	2	11-13	20 SEU	4	1	Inertia/Albedo	5/10/15/20/25	+5	#13-p6
Sonic Hammer	325	5	--	20 SEU	--	1	-	5/10/15/-/-	+0 (+10)	#13-p7
- hammer end (powered)	--	--	2d10 + 4d10 (sonic)	--	2	--	Inertia/Sonic	--	--	#13-p7
- spike end (not powered)	--	--	13-15	--	--	--	Inertia	--	--	#13-p7
Blastaxe (beam)	300	2	16-18	20SEU	2	1	Albedo	5/15/-/-	--	#5-p16
- melee	--	--	16	--	--	--	Inertia	--	--	#5-p16
Defense Rod ²	500	2		17 20 SEU	2 per hit	1	STA check	--	--	#7-p23
- flamethrower mode	--	--		18 3 fuel cell	-	1	Inertia	--	--	#7-p23

* "SEU" means any source of SEU can be used (clip, belt pack or backpack). "20 SEU" means only energy clips can be used. "Power Pack" means only belt or back packs can be used.

² Might be difficult to find or even illegal to purchase/possess.

27-30

31-34

34-38

39-40

Defenses and Ammunition

Ammo Type	Cost (Cr)	Wgt (kg)	Energy/ rnds	Note	Source
Beam Weapon Ammunition					
Power Clip	100	--	20 SEU		AD
Power Backpack	250	4	50 SEU		AD
Power Backpack	500	10	100 SEU		AD
Caseless Gause rnds	50		100 rnds		#8-p52
Flamethrower fuel backpack	50		10 bursts	each	#3-p1
Defense Rod Fuel Cell	25	--	1 blast		#7-p23
			5		
Gyrojet Ammunition					
Pistol Jetclip	10	--	5		AD
Rifle Jetclip	20	--	10 rnds		AD
Extnd Jetclip, Pistol	20		15 rnds	-1 IM	#3-p3
Extnd Jetclip, Rifle	40		15 rnds	-1 IM	#3-p3
Linked Jetclip, Pistol	100		10 rnds	+10% ATT	#3-p3
Linked Jetclip, Rifle	200		10 rnds	+10% ATT	#3-p3
Extnd Linked Jetclip, Pistol	200		15 rnds	-1 IM	#3-p3
Extnd Linked Jetclip, Rifle	350		15 rnds	-1 IM	#3-p3
Doze Jetclip, Pistol	20		10 rnds	STA chk	Drag#112
Doze Jetclip, Rifle	30		10 rnds	STA chk	Drag#112
Extnd Doze Jetclip, Pistol	55		15 rnds	-1 IM	#3-p3
Extnd Doze Jetclip, Rifle	95		15 rnds	-1 IM	#3-p3
Poison Jetclip, Pistol	50		10 rnds	S5/T10	Drag#112
Poison Jetclip, Rifle	100		10 rnds	S5/T10	Drag#112
Extnd Poison Jetclip, Pistol	125		Nov-13	-1 IM	#3-p3
Extnd Poison Jetclip, Rifle	200		15 rnds	-1 IM	#3-p3
Tangler Jetclip, Pistol	30		10 rnds	entangle	Drag#112
Tangler Jetclip, Rifle	60		13-15	entangle	Drag#112
Extnd Tangler Jetclip, Pistol	95		16-18	-1 IM	#3-p3
Extnd Tangler Jetclip, Rifle	95		16	-1 IM	#3-p3
Frag Jetclip, Pistol	50		17	3d10 dmg	#3-p3
Frag Jetclip, Rifle	100		18	4d10 dmg	#3-p3
Extnd Frag Jetclip, Pistol	125		18	-1 IM	#3-p3
Extnd Frag Jetclip, Rifle	200		19-20	-1 IM	#3-p3
Fast Jetclip, Pistol	50		21-26	-1 die dmg	#3-p3
			27-38		
Fast Jetclip, Rifle	100		27-30	-1 die dmg	#3-p3
			31-34		
Extnd Fast Jetclip, Pistol	125		34-38	-1 IM	#3-p3
Extnd Fast Jetclip, Rifle	200		39-40	-1 IM	#3-p3
Grenade Bullet	3	--	1 round		AD
Grenade Shell	8	--	1 round		AD
Rocket	15	4	1 round		AD
Heavy JetClip	50		10 rnds		#10-p14
HRG Jetclip	50		5 rnds		#14-p36
Machine Gun Jet-Cassette	100		100 rnds		#14-p36
PGR Long Range Jetclip	40		5 rnds		#14-p36

Projectile Weapon Ammunition

Pistol Bulletclip	2	--	20 rnds		AD
Rifle Bulletclip	5	--	20 rnds		AD
Extnd Pistol Bulletclip	5	--	30 rnds	-1 IM	#2-p14
Extnd Rifle Bulletclip	10	--	30 rnds	-1 IM	#2-p14
Pistol Needleclip	10	--	10 rnds		AD
Rifle Needleclip	20	--	10 rnds		AD
Machine Gun Belt	50	4	200 rnds		AD
Recoilless Shell	10	1	1 round		AD
Scattergun Shotclip	10		10 shot		#4-p17
Scattergun Shotshells	10		20 shells		#4-p17
Det-Net	500		1		#13-p8
Mag-Net	100		1		#13-p8
Tase-Net	200		1		#13-p8
Pulse Rifle Clip	50	--	99 bullets		#5-p16

Ammo Type	Cost (Cr)	Wgt (kg)	Energy/ rnds	Note	Source
Projectile Weapon Ammunition					
Pulse Rifle Grenade	25	--	1 grenade		#5-p16
EMS Shells	250	1	4 shells		#7-p23
Acid gel rnds	20		10 rnds	Airgun	#7-p23
Practigel rnds	10		50 rnds	Airgun	#7-p23
Dozegele rnds	20		10 rnds	Airgun	#7-p23
Toxin Gel rnds	30		10 rnds	Airgun	#7-p23
Air Cartridge	10	--	1000 psi		Airgun #7-p23
Smallarm Bullet ²	25	--	1 round		#6-p26
Napalm Tank	50	5	10 blasts		#3-p1
TanglerClip	25		10 rnds	Tanglgun	#5-p2
Buckshot	1		1 shell	shotgun	#9-p27
Sabot Slug	2		1 shell	shotgun	#9-p27
Explosive Sabot Slug	5		1 shell	shotgun	#9-p27
Balor Quickloader	5	-	7	revolver	#15-p73

Archaic Weapon Ammunition

Arrow	2	--	20 arrows		AD
Powder and Shot	10	1	20 rnds		AD

Sentry Gun Ammunition

Type1 Parabattery	600	25	50 shots		AD
Machine Drum	200	5	50 bursts		#5-p16
Frag Cylinder	500	8	25 shots		#5-p16
Incendiary Cylinder	500	8	25 shots		#5-p16

Mounted/Vehicle Ammunition

Bullets	500		Per 100	0.1 m3	#15-p24
Shells					#15-p24
Small	75		10 shells	0.1 m3	#15-p24
Medium	150		10 shells	0.2 m3	#15-p24
Large	225		10 shells	0.3 m3	#15-p24
SEU Drum	5,000	25	1,000 SEU	0.2 m3	#15-p24
Rocket					#15-p24
Small	250	2	3 rockets	0.3 m3	#15-p24
Medium	500	2	3 rockets	0.4 m3	#15-p24
Large	750	2	3 rockets	0.5 m3	#15-p24
Missile					#15-p24
Small	400	3	3 missiles	0.3 m3	#15-p24
Medium	800	3	3 missiles	0.4 m3	#15-p24
Large	1,200	3	3 missiles	0.5 m3	#15-p24
Napalm Drum	250	3	Each drum	0.2 m3	#15-p24

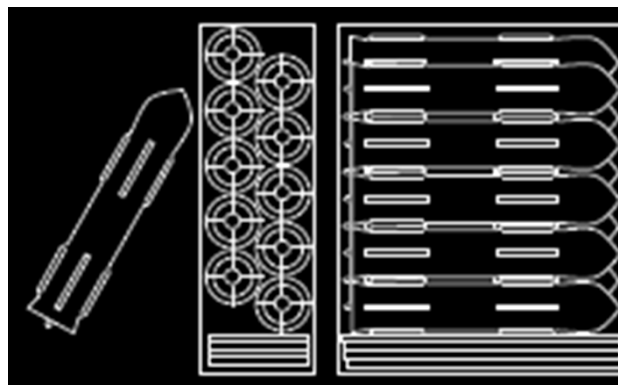

Defenses and Ammunition

Defense	Cost (Cr)	Wgt (kg)	Energy	Defense Against	Source
Power Screens					
Albedo Screen	2,000	2	1 SEU/min	lasers	AD
Gauss Screen	1,000	2	2 SEU/hit	electric stun	AD
Holo Screen	1,000	2	1 SEU/min	--	AD
Inertia Screen	2,000	3	2 SEU/hit	ballistic/melee	AD
Sonic Screen	2,000	2	1 SEU/min 2 SEU/hit	sonic	AD
Displacement Screen	2,000	3	1 SEU/turn	50% total miss	#6-p26
Defensive Suits					
Albedo Suit	500	1	100 points	laser	AD
Military Skeinsuit	300	1	50 points	ballistic/melee	AD
Civilian Skeinsuit	500	1	50 points	ballistic/melee	AD
Security Skeinsuit	150	1	25 points	Ballistic/Melee	#1-p2
Stealthskin	80	-	special	-	#1-p2
Inertia Wall	5,000	100	2 SEU/turn + 2 SEU/die	ballistic	#5-p16
Shocksuit - Defensive	200		10 points	electric stun	#7-p23
Shocksuit - Offensive	7,500		10 pnts/4 SEU attack	electric stun	#7-p23
Shipsuit	1,500	3.5	100 pnts, 1 SEU/turn	Inertia/Vacuum	#9-23
Powered Skeinsuit	8,300	250	50 pnts, 1 SEU/min	Inertia/Lasers	#9-23
Flak Armor	750	2	10 hits*	Inertia	#9-23
Albedoline Flak Armor	1,250	2	10 hits*/100 points	Inertia/Lasers	#9-23
Dead Suit	400	1	50 points	IR Detection	
Slipsuit	600	1	100 points	Tangler/Holding	Drag#112
Asbestos Suit	500	3	100 points	Heat/Fire	
Chillsuit	400	1		Cold	SFAD5
Inssuit/Radsuit	1,000	3		Radiation	
Enviromental Suit	100	2		Enviroment	Drag#112
Hostile Enviroment Suit	2,000	20	100 points	Extreme Enviroments	
Armor					
Partial Polyplate	1,250	8	100 pts	-5 RS/DEX	ADrmst
Full Polyplate	3,000	15	250 pts	-10 RS/DEX	ADrmst
Power Armor	5,600	25	250	--	#14-p39

* Absorbs 3/4 Interia damage instead of 1/2 like a Skeinsuit

Power Armor Equipment	Cost (Cr)	Mass (kg)	Notes	Source
Sungoggles	2	--	--	#14-p39
Compass	11	--	HUD in lower right corner	#14-p39
Flashlight	6	--	Mounted to Helmet, shoulder or forearm	#14-p39
Gas Mask	33	--	--	#14-p39
IR goggles	330	--	Fits over visor (removable)	#14-p39
IR Jammer	550	1	--	#14-p39
Magnigoggles	220	--	Fits over visor (removable)	#14-p39
Poly-Vox	1,650	1	Helmet mount only	#14-p39
Radiophone	550	4	Helmet mount only	#14-p39
Toxi-Rad Gauge	25	--	HUD in upper right corner	#14-p39
HUD Targeting System	2,500	--	See Description	#14-p39

Battlesuit	Cost (Cr)	Size/ Mass (kg)	Power Type	STR	STA	DEX Mod	RS Mod	IM Mod	Source
Standard	50,000	3m/500	Type I Parabattery	400	400	-20	-15	-2	#9-p16
Vrusk	55,000	3m/400	Type I Parabattery	300	300	-15	-15	-2	#9-p16

Combat Armor	Cost (Cr)	Wgt (kg)	Defense Simplified	DEX/ RS Mod	Source
Light Armor	650	7	20%	-0	#5-p15
Medium Armor	1,200	15	40%	-5	#5-p15
Heavy Armor	2,000	25	60%	-10	#5-p15

Verses Needlers x2 protection

Verses Sonic/Beam x1/2 protection

Verses shock, stun or tangler effects no protection

*Special military permit needed to purchase or have repaired

Def. chance is reduced by 5% after every combat if armor was hit. Can be repaired.

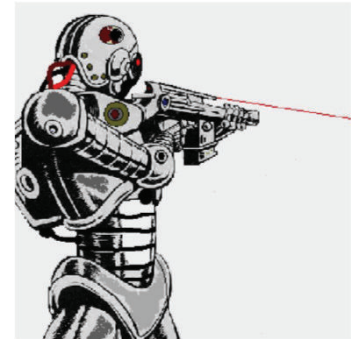
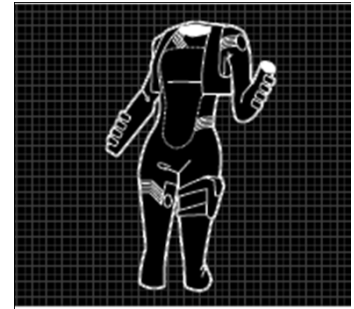

Equipment

Miscellaneous Equipment	Cost (Cr)	Wgt (kg)	Source
Advanced Chronocom	250		#8-p1
All-weather blanket	20	--	AD
Anti-Shock Implant (r)	2,000	--	AD
Autodoc	50,000	200	#8-p49
- Additional species programming/equipment	5,000	--	#8-p49
- Extra Capsules (max 10)	10,000	--	#8-p49
Binders	20		
Biocom		-	5
Bio-Sampler	20	1	5
Bounty Shackles*	500	--	5
Breathing Bag (Vrusk or Dralosite)	400	--	SFAD6
- Tank	50	5	SFAD6
- Refil	10		SFAD6
Breathing Mask	100	1	SFAD5
- Tank	50	5	SFAD5
- Refil	10		SFAD5
Cargo Cart	1,000	350	
Chronocom (r)	100	--	AD
Climbing Gear	150	12	AD
Compass (r)	10	--	AD
Crete Sprayer	150	5	
- Tank of Crete	40	1	
Detangler Harness	500	3	#6-p26
Dralosite Web Harness	10		Nov-13
Duraraft	90	3	#1-p3
Emergency Beeper	25		
EMP Field Grenades	750	1	13-15
Envirotent	40	3	16-18
Everflame	50	--	16
Exoskeleton*	2,000	5	17
Explorers Boots	35	1	18
Explorers Fatigues	80	2	18
Explorers Vest	50		19-20
Flares (normal)	10		21-26
Flashlight	5	--	27-38
Food Purifier	650	20	27-30
Freeze Field	1,200	4	31-34
Gas Mask (by species)	30	--	34-38
Grapple Link Gun (5/10/30/--/--)	300	4	39-40
- Link-bolts (rack of 3, 30m, 300 kg test wgt)	50	1	#3-p20
Holo-corder	15,000	3	AD
Holo-Field Scrambler*	1,500	1	#6-p26
- Belt Case	25		#6-p26
- replacement antennae	25		#6-p26
Holoflare	5	1	AD
Holo-Projector	1,000	5	AD
Hot Rations Pack	10	1	
Inflatable Life Raft	100	7	AD
Inflatable Tent	200	30	AD
Infralight Lens	30	1	
Infra-red Goggles (r)	300	--	AD
Infra-red Jammer* (r)	500	1	AD
Jetpack	12,000	40	AD
Jumpboots	70	--	#1-p3
Life Jacket	10	1	AD
Machete	30	3	AD
Magnigoggles (r)	200	--	AD
Mine Kit (not including grenade)	20	1	#5-p2
- Motion Sensor	40	1	#5-p2
- Pressure Sensor	35	1	#5-p2
- Proximity Sensor	45	1	#5-p2

(r) Can be installed on a robot for +10% Credits
 * Must be plugged into an SEU source.

Miscellaneous Equipment	Cost (Cr)	Wgt (kg)	Source
- Time Delay Sensor	25	1	#5-p2
- Voice Activator	150	1	#5-p2
- Photon Sensor	20	1	#5-p2
Motion Tracker	500	1	#5-p16
Oxy-Drug Injector	500		Drag#112
Parawing	200	3	
Photo-voltaic Paint	250	1	#8-p49
Plasti-Poncho	30	3	
Poly-vox	1,500	1	AD
Pressure Tent	500	50	
Radiophone (r)	500	4	AD
Rebreather Mask (by species)	100	1	#3-p20
Rope	2	1	AD
Signal Amplification Tower*	750		#8-p1
Solvaway	10	--	AD
Subdermal Talk	1,000		
Subspace Radio	20,000	100	AD
Suc-Set	70	10	
Sungoggles	2	--	AD
Survival Kit	150	6	#1-p3
Survival Rations	2	--	AD
Tactical Vest	750	2	#4-p16
Tag Tracker (5 km radius range)	750	1	#3-p20
- Med Trace-Tag (1)	100	--	#3-p20
- Trace-Tags (3)	100	--	#3-p20
Thermosign Generator	1,000	100	Drag#112
Thruster Pack	500	5 + fuel	#3-p20
- Replacement Gel Tank	100	5	#3-p20
Tornadium D-19**	50	1	AD
Toxy-Rad Guage (r)	20	--	AD
Underwater Flares	1		
Underwater Rebreather	2,000	10	
Universal Antibody	100		Drag#112
Utility Gauntlet	100	-	#15-p73
Utility Pauldron addon	100	-	#15-p73
- Chronocom Component	110	-	#15-p73
- Demolitions Component**	65	2	#15-p73
- Envirokit Component	750	2	#15-p73
- Firex Spray Component	55	-	#15-p73
- Gasmask Component	35	-	#15-p73
- Healthview Component	100	1	#15-p73
- Holoflare Component	12	-	#15-p73
- Holorecorder Component	55	-	#15-p73
- IR Jammer Component	55	-	#15-p73
- Medkit Component	750	2	#15-p73
- Nutrition Component	15	2	#15-p73
- Polylang Component	1650	-	#15-p73
- Radiophone Component	750	2	#15-p73
- Robcomkit Component	750	2	#15-p73
- Solvaway Component	25	-	#15-p73
- Survival Component	70	-	#15-p73
- Tag Tracker Component	825	-	#15-p73
- Techkit Component	750	2	#15-p73
- Toxy-Rad Component	22	-	#15-p73
- Water Supplement Component	10	2	#15-p73
- Zipline Component	10	1	#15-p73
Variable Timer	5	--	AD
Visocom	50	--	#1-p3
Vitasalt Pills	1	--	AD
Water Pack	4	4	AD
Wide-Field Recorder	100	--	#1-p3

** Can only be legally purchased by someone with Demolitions skill (certification)

Tool Kits	Cost (Cr)	Wgt (kg)	Source
Techkit	500	12	AD
Robcomkit	500	10	AD
Medkit	500	10	AD
-Antibody Plus	5	--	AD
-Antitox	5	--	AD
-Biocort	10	--	AD
-Omnimycin	5	--	AD
-Staydose	5	--	AD
-Stimdose	5	--	AD
-Telol	10	--	AD
-Accelerator	10	--	Drag#112
-Anesthis Plus	5	--	Drag#112
-Oxydrug Refill	30	--	Drag#112
-Staput	25	--	AD
-Analgesic	1	--	AD
-Purgatorrive	2	--	AD
Envirokit	500	10	AD
Engineerkit	2,500	12	
- Density Scanner	500	5	Drag#112
MakupKit	250	5	
Pocket Tool	20	--	
Laser Power Torch	5,000	100	
- Power Pack	500	20	
Portable Space Welder	300	20	Drag#112
Lockit (mech)	500	2	
Lockit (elec)	1,000	3	

Parabattery	Cost (Cr)	Wgt (kg)	SEU
Type 1	600	25	500
Type 2	1,200	50	1,000
Type 3	2,300	100	2,000
Type 4	4,500	200	4,000

Generators	Cost (Cr)	SEU/ Hour	Maintenance
Type 1	10,000	500	100Cr/d
Type 2	20,000	1,000	200Cr/d
Type 3	40,000	2,000	400Cr/d
Type 4	80,000	4,000	800Cr/d

Weapon Assessoris	Cost (Cr)	Wgt (kg)	Effect	Source
Telescopic Sight	+50	+.5	Use range category one step better. No effect fo #3-p3	
Laser Sight	+70	+.5	+10 to hit in PB no help past 5m.	#2-p15
Flashlight	+10	+.5	-1 IM due to the added bulk.	#2-p15
DIRK Bayonet	+10	+.5	1d10 + PS adds to damage caused in melee.	#2-p15
CKA Fast-draw Holster	65	--	Ignore -3 IM for holstered weapon	#2-p14
Gyrojet Recoil Compensator	+100	--	+10 to hit in 0-G or freefall	#3-p3
Gyrojet Target Link	+500	--	+10 to hit with linked ammunition	#3-p3



Equipment

Biogenic Equipment	Cost (Cr)	Wgt (kg)	Source
Aquabreather	50	0.5	#15-p73
Biocontacts	150	-	#15-p73
- low light	350	-	#15-p73
- infrared	450	-	#15-p73
- macroscope x4	450	-	#15-p73
- each extra x1	+100	-	#15-p73
- microscope x4	450	-	#15-p73
- each extra x1	+100	-	#15-p73
- addn spectra (ultra, etc)	+500	-	#15-p73
Ear Slugs	10	-	#15-p73
- nutrient solution	1/m	-	#15-p73
Packing Seeds /kg	5	1	#15-p73
Pod Crates /liter	2	0.1	#15-p73
SmartFlesh	50	-	#15-p73
SynthPlasma /liter	100	1	#15-p73

Energy Travel Equipment	Cost	Source
Control Computer	30,000	#16-p88
Teleport Program	20,000	#16-p88
Diagnostic Program	6,000	#16-p88
Security Program	8,000	#16-p88
M.T.C. Unit	575,000	#16-p88
Molecular Scanner	200,000	#16-p88
Medical Bio-Scanner	150,000	#16-p88
Containment Shield	60,000	#16-p88
Transmitter Array	250,000	#16-p88
Receier Array	250,000	#16-p88
Data Interpreter Unit	125,000	#16-p88
Terminal Pod	55,000	#16-p88
Large Terminal Pod	85,000	#16-p88
Power Generator	200,000	#16-p88
CCN Buffer Unit	65,000	#16-p88
TRN Relay Unit	150,000	#16-p88
TRN Capacitor	25,000	#16-p88
Encryption Program	30,000	#16-p88
HALO System*	375,000	#16-p88

* restricted to military use only

Standard Equipment Pack
150 Cr - 1 kg
Chronocom
Coveralls or uniform
Doze Grenade
First Aid Pack
ID Card
Pocket Flashlight
Pocket Tool
Staydose
Stimdose
Sungoggles
Survival Rations (5 days)

Implant Equipment	Cost (Cr)	Source
Chrono Tattoo	35	#15-p21
Tattoo Implant	75	#15-p21
Standard Ocular Implant	10,000/eye	#15-p21
HiTech Ocular Implants	15,000/eye	#15-p21
Implanted Chronocom	3,500	#15-p21
Implant Programmer Progit	1,000	#15-p21
Implant Diagnostic Program	1,000/FP	#15-p21
Implanted Claws	3,000/PS	#15-p21
Retractable Reaper Blades	15,000	#15-p21
Virtual Reality Visual Cortex Stimulator	3,000*	#15-p21

*If purchased on loan the length of a contract is five years and cost 200 credits per month.

Cybernetic Implants	Cost (Cr)	Source
Biobattery, Large	250,000	#14-p9
Biobattery, Moderate	125,000	#14-p9
Biobattery, Small	18,750	#14-p9
Emergency Source Jack	200	#14-p9
Emergency Source Slot	100	#14-p9
Active Sonar Implant	18,750	#14-p9
Autofire Arm Implant	20,000	#14-p9
Blasthand Implant	6,500	#14-p9
Electrohand Implant	50,000	#14-p9
Environmental Implant	50,000	#14-p9
Holo-field Implant	100,000	#14-p9
holo-field Scrambler Implant	150,000	#14-p9
Laserhand Implant	60,000	#14-p9
Reflex Implant, Cutting edge	2,000,000	#14-p9
Reflex Implant, Improved	1,000,000	#14-p9
Robotic Arm	100,000	#14-p9
Robotic Leg	100,000	#14-p9
Robotic Torso	1,500,000	#14-p9
Rockethand Implant	20,000	#14-p9
Sonic Claw	30,000	#14-p9
Sonic Talon	5,000	#14-p9
Sonichand Implant	50,000	#14-p9
Subdermal Plating, Military Grade	400,000	#14-p9
Subdermal Plating, Security Grade	150,000	#14-p9

Must be performed in an appropriate medical facility. 20%-40% chance to be available on any planet.



Equipment

Prosthetics	Cost (Cr)	Source
Finger	500	#14-p9
Hand	5,000	#14-p9
Foot	1,500	#14-p9
Leg	6,000	#14-p9
Arm	7,500	#14-p9
Eye	5,500	#14-p9
Nose	750	#14-p9
Ear	550	#14-p9

Bionic Implants	Cost (Cr)	Source
Biocom	2,000	#14-p9
Cyber-Claw	8,000	#14-p9
Cyber-Talon	2,000	#14-p9
Dermal Chrome	12,000	#14-p9
Dermal Climbing Pads	3,000	#14-p9
Dermal Infra-red Treatment	5,250	#14-p9
Eidetic Implant	525	#14-p9
Flamefinger	750	#14-p9
Foot Anchors	800	#14-p9
Gill Implants	10,000	#14-p9
Harmonic Subdermal Gel Implants	10,000	#14-p9
Identity Card Implant	2	#14-p9
Infra-red Ocular Implant	12,000	#14-p9
Knuckleplating	100	#14-p9
Liquifilter Implant	330	#14-p9
Low-Light Ocular Implant	12,000	#14-p9
Lungfilter Implant	6,800	#14-p9
Magnasole	1,000	#14-p9
Magnification Ocular Implant	8,000	#14-p9
Med-Trace Tag Implant	100	#14-p9
NeuralComp	1,700,000	#14-p9
Northpoint Implant	225	#14-p9
Plasteel Cutter Implant	1,200	#14-p9
Reflex Implant, Basic	500,000	#14-p9
Retractable Finger Blades	600	#14-p9
Self-Repair Implant	250,000	#14-p9
Skeletal Augmentation	1,250,000	#14-p9
Smuggling Compartment Implant	600	#14-p9
Synth-eyes	1,000	#14-p9
Synth-flesh	5,500	#14-p9
Synth-hair	1,200	#14-p9
Timepiece Implant	300	#14-p9
Toxy-Rad Gauge Implant	375	#14-p9
Trace-Tag Implant	25	#14-p9
UniSolve Spray Implant	7,500	#14-p9
Universal Translation Implant	22,500	#14-p9

Must be performed in an appropriate medical facility. 50%-70% chance to be available on any planet.



Robots and Computers

Robots

Standard Robot	Cost (Cr) per Robot Level						Movement Rate	Source
	1	2	3	4	5	6		
Maintenance	2,200	2,500	3,000	4,000	--	--	60 m/turn	AD
Heavy Duty	5,200	5,500	6,000	7,000	--	--	30 m/turn	AD
Combat	--	3,500	4,000	5,000	--	--	120 m/turn	AD
Reconnaissance	--	4,500	5,000	7,000	--	--	120 m/turn	
Security	--	3,500	4,000	5,000	7,000	11,000	90 m/turn	AD
Service	--	--	4,000	5,000	7,000	11,000	30 m/turn	AD
Cybernetic	--	--	5	5,000	7,000	11,000	30 m/turn	AD
Repair	--	--	5	37,000	39,000	43,000	60 m/turn	#4-p20
Medical	--	--	5	52,000	54,000	58,000	90 m/turn	#4-p20
Warbot	--	--	--	--	12,000	16,000	120 m/turn	AD
Robot Brain	--	--	--	--	--	17,000	30 m/turn	AD

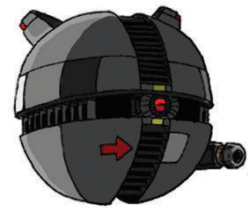

Robot Base Cost	Skill Level						Source
	1	2	3	4	5	6	
Cost(Cr)	200	500	1,000	2,000	4,000	8,000	AD

Robot Design	Cost (Cr)	Source
BodyTypes		
-Standard	2,000	AD
-Heavy Duty	5,000	AD
-Anthropomorphic	3,000	AD
Extra Limbs		
		Nov-13
-Standard Pair	800	AD
-Heavy Duty Pair	1,200	AD
-Anthropomorphic	1,000	13-15
Altered Movement		
		16-18
-Hover	2,000	16
-Rotor	5,000	17
-Rocket	10,000	18
Special Programs		
		18
-Restrain (min Level 2)	500	19-20
-Self Defense (min Level 2)	500	21-26
-Attack/Defense (min Level 2)	1,000	27-38
-Search & Destroy (min Level 4)	3,000	27-30
-Computer Link (min Level 4)	4,000	31-34
-Security Lock (min Level 1)	500	34-38
-Medical (min level 4)	50,000	39-40
-Technician (min level 4)	35,000	#4-p20
-Robotics (min level 4)	40,000	#4-p20
- Survey (various) (min level 2)	2,000	SFKH2
- Site Management (min level 4)	3,000	SFKH2
- Sample Collection (min level 1)	750	SFKH2
- Facial Recognition (min level 2)	750	#16-p65
- Interference	1000	#16-p65
- Security Grid	500	#16-p65
- Signal Jamming	1000	#16-p65
- Signal Optimizer	500	#16-p65
- Tactical Analysis	1000	#16-p65
- Translator	1000	#16-p65
- Transmission Analysis	1000	#16-p65
- Voice Simulator	500	#16-p65

Computer/Robot Equipemnt	Cost (Cr)	Wgt (kg)	Source
Voice Control	100	1	#2-p3
Speech Output	100	1	#2-p3
Somatic Control	300	*	#2-p3
Holographic Keyboard	250	*	#2-p3
Holographic Display	200	2	#2-p3
Botlink	500		#16-p63
Bot Restrainer	150		#16-p63
Bot Tracker	70		#16-p63
C-Thru Analyzer	1,500		#16-p63
Charging Dock	400		#16-p63
Credit Scanner	700		#16-p63
Cutting Torch	500		#16-p63
Holoprojector I	1,000		#16-p63
Holoprojector II	1,500		#16-p63
Holorecorder I	700		#16-p63
Holorecorder II	1,200		#16-p63
Plastiscreen	300+		#16-p63
Dart Attachment	200		#16-p63
Dose Darts (5)	10		#16-p63

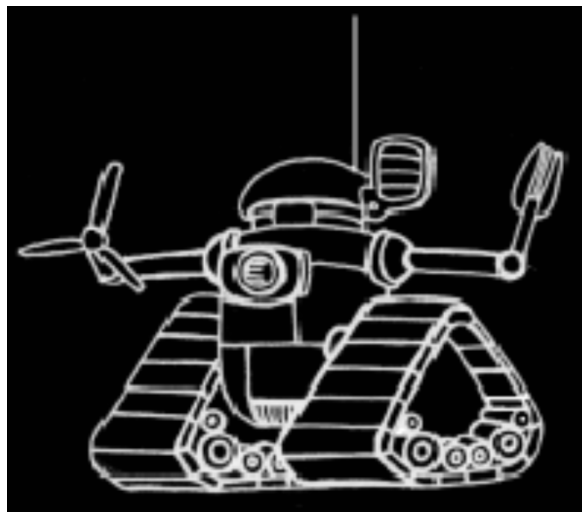

Computers

Function Point Total	Resulting Level	Wgt (kg)	Source
1-10	Level 1	3	AD
11-30	Level 2	8	AD
31-80	Level 3	20	AD
81-200	Level 4	100	AD
201-500	Level 5	300	AD
500+	Level 6	800+	AD

Computers cost 1,000 x the total # of Function Points.

Computer Program	Function Points for Levels						Source
	1	2	3	4	5	6	
Analysis	1	2	4	8	16	32	AD
Bureaucracy	2	4	8	16	32	64	AD
Commerce	3	6	12	24	48	96	AD
Communication	3	6	12	24	48	96	AD
Computer Security	2	4	8	16	32	64	AD
Industry	3	6	12	24	48	96	AD
Information Storage	2	4	8	16	32	64	AD
Installation Security	3	6	12	24	48	96	AD
Language	1	2	4	8	16	32	AD
Law Enforcement	4	8	16	32	64	128	AD
Life Support	4	8	16	32	64	128	AD
Maintenance	2	4	8	16	32	64	AD
Robot Management	2	4	8	16	32	64	AD
Transportation	3	6	12	24	48	96	AD
Drive Program, Chem	3	6	12	--	--	--	KH
Drive Program, Ion	--	--	12	24	--	--	KH
Drive Program, Atomic	--	--	--	32	64	128	KH
Astrogation	3	6	--	24	--	--	KH
Life Support	1	2	3	4	--	--	KH
Alarm	1	2	4	8	16	32	KH
Computer Lockout	1	2	4	8	16	32	KH
Damage Control	1	4	8	16	32	64	KH
Excavation	--	4	--	--	--	--	KH
Processing (OPL)	--	--	--	12	--	--	KH
Processing (MR)	--	--	--	16	--	--	KH
Agricultural	3	--	--	--	--	--	KH
Cargo Arm	--	4	--	--	--	--	KH
Laser Cannon	3	--	--	--	--	--	KH
Laser Battery	4	--	--	--	--	--	KH
Proton Beam Battery	--	8	--	--	--	--	KH
Electron Beam Battery	--	6	--	--	--	--	KH
Disruptor Beam Cann	--	8	--	--	--	--	KH
Assault Rocket	4	--	--	--	--	--	KH
Rocket Battery	--	6	--	--	--	--	KH
Torpedo	3	--	--	--	--	--	KH
Mines	1	--	--	--	--	--	KH
Seeker Missile	--	--	9	--	--	--	KH
Laser Pod	3	--	--	--	--	--	KH
Electron Screen	--	6	--	--	--	--	KH
Proton Screen	--	8	--	--	--	--	KH
Stasis Screen	--	--	12	--	--	--	KH
Interceptor Missile	--	--	12	--	--	--	KH

Computers	Cost (Cr)	Wgt (kg)	Function Points	Source
Headset Computer	10,500	0.5	8	#9-p6
Hand Computer	7,000	2	*	SFAD6

*provides remote access to a large computer

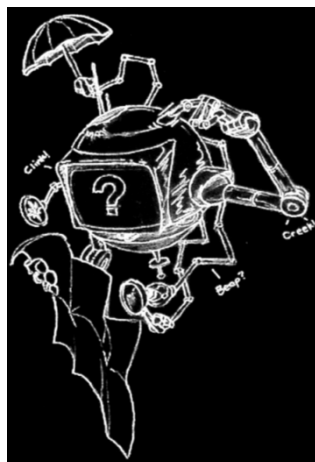
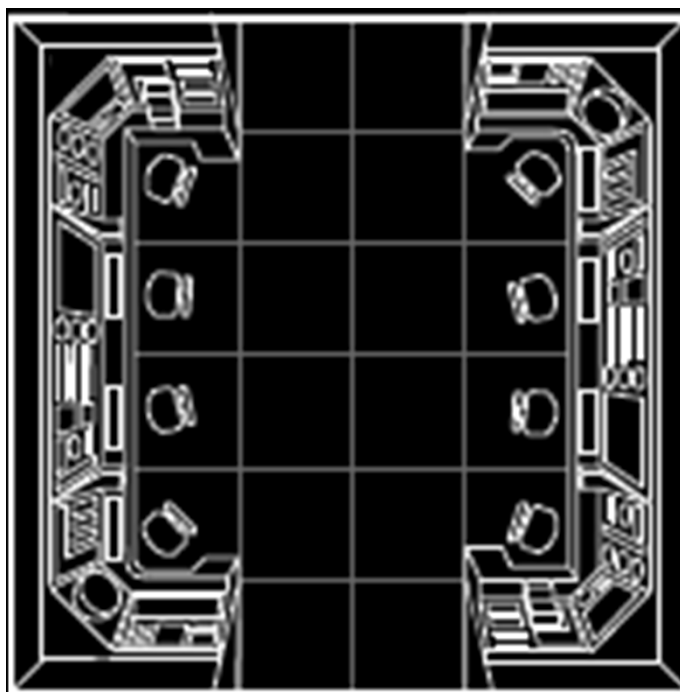
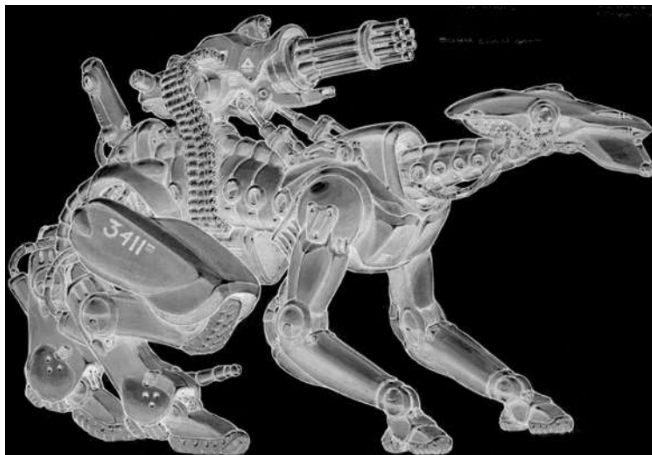

Robot Designs

Robots	Cost (Cr)	Level	Body Type	Limbs	Movement Type	Movement Rate	IM/RS Att	STA	Damage	Source
PDG Engineering Control Model EC-5	14,547	5	Anthropomorphic (humanoid)	Two arms Two hands	Standard Track		+8/80	100	By weapon 2d10 punching	#14-p38
Programs Computer Link, Security Lock Equipment Spare Type I Parabattery, Chronocom, Toxy-Rad Gauge, Rocket Pack (100 hrs), Anchor (100 m)										
PDG Engineering Control Model EC-5(s)	29,907	6	Anthropomorphic (humanoid)	Bound 4 arms Bound 4 hands	Standard Track		+8/80	100	By weapon 2d10 punching	#14-p38
Programs Computer Link, Security Lock Equipment Spare Type I Parabattery, Chronocom, Toxy-Rad Gauge, Rocket Pack (100 hrs), Anchor (100 m), Skein Armor, Radiophone, Anti-Shock device, Holo-screen (camouflage), IR goggles, IR Jammer, Albedo screen										
Neotech HWK-2B Medical Bot	4	4	5 two arms (Bl- Medkit)	Two legs	Two legs	10m/t norm. 90m/t max.	+6/60	100	By weapon 2d10 punching	#4-p20
Programs Medical, Security Lock, Attack/Defense Equipment Medkit, Chronocom, Compass, IR goggles, Magnigoggles, Radiophone, Toxy-Rad Gauge, Albedo screen, 50 SEU backpack, 100 SEU Backpack, Laser Rifle										
Wartech BEE-MKII Reconnaissance Robot	2	2	Standard Body	Two retractable hands	Hover	10m/t norm. 120m/t max.	+5/50	100	By weapon	#4-p20
Programs Security Lock, Attack/Defense Equipment Chronocom, Compass, IR goggles, Magnigoggles, Radiophone, Videocom, Holo Screen, 50 SEU backpack, 100 SEU Backpack, Integrated laser rifle										
Robotic Steed	4,500	3	Standard Body	4 legs	Walk/Gallop	10m/t norm. 120m/t max.	+6/60	100	Robotic Hoof 2d10	#8-p53
Programs Security Lock, Attack/Defense Equipment None										
Raupp Robotics RR41 'Fury'	17,526	3	Heavy Duty	2 arms	Standard Track	120m/t max.	0.1	500	By weapon	
Programs Attack/Defense, Search & Destroy Equipment Chronocom, IR Goggles, Compass, Machine Gun (20 bursts), Grenade Mortar (8 shells: 4 frag, 2 incendiary, 2 smoke)										
Alpha-class Security Robot	2	2	Standard Body	2 Mechanical Arms	2 Treads	10m/t norm. 90m/t max.	+5/50 50	100	By weapon	#1-p12
Programs Restrain, Security Lock Equipment Chronocom, powerlight, 5 doze grenades, 5 tangler grenades.										
Beta-class Security Robot	3	3	16 none	17	Hover	10m/t norm. 250m/t max.	+6/60 60	100	By weapon	#1-p13
Programs Restrain, Security Lock, Self Defense Equipment Chronocom, owerlight, Infra-red Goggles, Electrostunner, Albedo Screen, 50 SEU backpack, 5 doze grenade, 5 tangler grenades.										
Gamma-class Security Robot	5	5	19-20 21-26	2 Mechanical Arms	2 mechanical legs	10m/t norm. 90m/t max.	+8/80 80	100	By weapon 2d10 punching	#1-p13
Programs Attack/Defense, Security Lock, Computer Lock Equipment Chronocom, powerlight, IR Goggles, Toxy-Rad Gauge, Laser Pistol, Sonic Stunner, Albedo Screen, 100 SEU Power Pack, 5 Tangler Grenades, 5 Doze grenades										
Assassin Bot	5	5	31-34 34-38 39-40	2 Mechanical Arms	2 Legs Rocket Power	10m/t norm. 120m/t max. 100 kph cruiss 900 kph max	+8/80 80	500	4d10 sword x2 6d10 unarmed By weapon	
Programs Attack/Defense, Security Lock, Computer Lock, Search & Destroy Equipment Chronocom, Powerlight, IR Goggles, Magnigoggles, Toxy-Rad Gauge, Laser Pistol, 2 mono-blade katana, Albedo Screen, Military Skeinsuit, 100 SEU Powerpack, 5 Frag grenades, 5 Tangler grenades.										

Robot Designs

Robots	Cost (Cr)	Level	Body Type	Limbs	Movement Type	Movement Rate	IM/RS Att	STA	Damage	Source
STPAB-452		6	Standard Body	2 legs 2 Arms	Mechanical Legs	10m/t norm. 90m/t max.	+8/80 90	100	2d10 punching	#13-p47
Personal Assistant Bot	Programs Defense, Security Lock, Computer Link, Communications									
Equipment	Chronocom, Flashlight, Toxy-Rad Gauge, Poly-Vox									
PBM-202c		5	Standard Body	2 legs/2 Arms 1 tentacle	Mechanical Legs	10m/t norm. 90m/t max.	+8/80 80	100	2d10 punching	#13-p47
Maintenance Robot	Programs Repair Machinery, Information Storage, Security Lock, Computer Link									
Equipment	Chronocom, Toxy-Rad Gauge, Sonic Welder, Light duty laser Power torch, Techkit									
Remote Expedition Survey Robot		4	Heavy Duty	2 heavy duty arms	4 mechanical legs jetcopter engine		+7/70	500	By weapon	SFKH2
Programs	Attack/Defense, Computer Link, Topographical survey, Sample Collection, Photo Survey, Site Management									
Equipment	1 heavy laser. 100 SEU powerpack, 1 automatic rifle w/100 rounds									
GLLR-5 "Gorilla"		4	Anthropomorphic	2 mechanical arms	2 mechanical legs	10m/t norm. 60m/t max.	+8/80 70	100	2d10 punching	SFAD5
Recreation Robot	Programs Security Lock, Self-Defense, Wrestling (custom)									
Equipment	Type 1 Parabattery									
MLL-1E		2	Standard Body	4 mechanical arms	wheels	10m/t norm 60m/t max	+5/50 50 (2 att)	100	2d10 punching	SFAD5
Domestic Duty Robot	Programs Attack/Defense									
Equipment	Type 1 Parabattery									
SW-66 Sape Warden Robot		4	Anthropomorphic	2 mechanical arms	mechanical legs	10m/t norm 90 m/t max	+7/70 70	100	2d10 punching	SFAD5
Programs	Attack/Defense, Security Lock, Restrain									
Equipment	Infra-Red sensors, electrified dermal plating (as stunstick), Type 2 Parabattery									
FX-1T Maintenance Robot		4	Standard Body	2 mechanical arms 1 multi-tool*	wheels	10 m/t norm 60 m/t max	+5/50 60	100	2d10 punching	SFAD5
Programs	Security Lock, Self-Defense									
Equipment	Type 1 Parabattery, *multi-tool (equivalent of a Robcomkit and Techkit)									
BBL-¼ Reactor		3	Standard Body	2 mechanical arms 1 multi-probe	2 mechanical legs	10 m/t norm 60 m/t max	+6/60 60	100	2d10 punching	SFAD5
Maintenance Robot	Programs Security Lock									
Equipment	Robcomkit, Techkit, Type 1 Parabattery									
HIMDD-3 External		3	Standard Body	1 mechanical arms 1 multi-tool*	10 short mech legs	5 m/t norm 5 m/t max	+6/60 60	100	2d10 punching	SFAD5
Maintenance Robot	Programs Security Lock, Technician									
Equipment	Type 1 Parabattery, *multi-tool (equivalent of a Robcomkit and Techkit)									
DB-0 Security Robot		4	Standard Body	2 mechanical arms 1 laser power torch	2 mechanical legs	10 m/t norm 90 m/t max	+7/70 70	100	2d10 punching by weapon	SFAD5
Programs	Security Lock, Attack/Defense									
Equipment	Electrified Body (as stunstick), Albedo screen (50 SEU beltback), laser rifle, electro-stunner, 10 doze grenades, 10 tangler grenades, 100 SEU backback									

Robot Designs

Robots	Cost (Cr)	Level	Body Type	Limbs	Movement Type	Movement Rate	IM/RS Att	STA	Damage	Source
Violet-class Combat Robot		4	Anthropomorphic human	2 humanoid arms	2 humanoid legs	10 m/t norm 30 m/t max	+7/70 70	100	2d10 punching by weapon	
Programs Computer Link, Attack/Defense										
Equipment Chronocom, Radio/Computer Link, Radiophone, infra-red/Ultra-Violet Jammer, Radio Direction Finding, Toxi-Rad Gauge, Albedo Screen, Laser Pistol, Power Belt Pack (50 SEU)										
KLC 0-G Maintenance Robot		4	Standard Body	2 mechanical arms	gas jets	10 m/t norm 60 m/t max	+7/70 70	100	2d10 punching	SFAD6
Programs Computer Link, Security Lock, Self-Defense										
Equipment										
Ad-428 Courierbot	11,000	4	Standard (sphere)	non	Hoverfan	30 m/t 36 kph	+6/60	60	nil	#16-p61
Programs Face recognition, messaging, bureaucracy, personality, communication, language, info storage, commerce										
Equipment Flatscreen display, magnavision, holorecorder, holodisplay, homing beacon, credit reader, bot tracker, universal port, Communications Relay, 20 SEU (rechargeable)										
Spider II Personal Robot		2	Standard Body cylinder	4 manipulator arms 2 sensor arms	air jets (weightless)	60 m/t max	+5/50 50	50	as weapon	SFKH3
Programs Computer Link, Attack/Defense, Maintenance										
Equipment Type I parabattery, electrostunner, sonic stunner, self-destruct (as frag grenade)										
Dock Robot		2	Standard Body cylinder	4 sturdy arms	air jets (weightless)	60 m/t max	+5/50 50	75	2d10 ramming	SFKH3
Programs Computer link, maintenance										
Equipment type I parabattery.										
Heavy Duty Work Pod		2	Heavy Duty	2 heavy duty arms	air jets (weightless)	30 m/t	+5/50 50	500	6d10 ramming	SFKH3
Programs computer link, maintenance										
Equipment Type II parabattery										

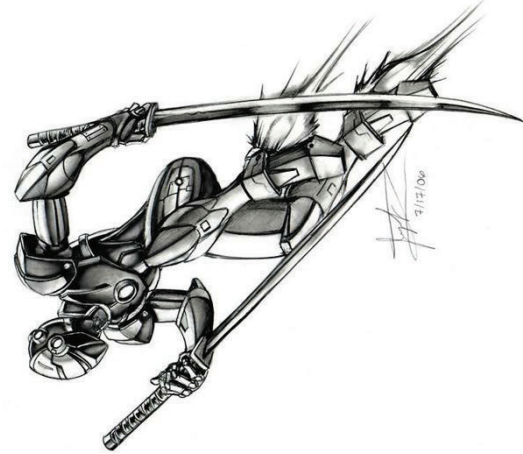
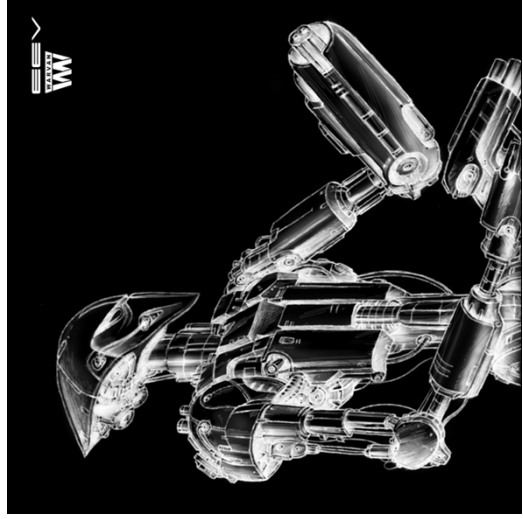

Vehicles and Transport 1

Vehicle Type	Size	Cost (Cr)	Rental (Cr)	Top Speed kph	Top Speed m/turn	Cruise Speed kph	Cruise Speed m/turn	Accel/Decel	Pass. Cargo Limit	Parabattery	Source	Mode of Transport	SP
G.N.A.T. (Military hover car)	2	49,850	--	180		100		59.5/35	2 20 kg/1.3 m3		#15-p24	Hover	500
Dune Crawler	5	44,000	--	100		50		50/50	4 7,000kg/25 m3		#15-p26	Ground	1100
Explorer	4	20,000	75+200/d	90	150	50	100	60/40	8 2,000kg/6 m3		AD	Ground	800
Ground Cycle	1	2,000	25+25/d	120	200	60	100	100/40	2 20kg/0.5 m3	Type I	AD	Ground	200
Ground Car	2	5,000	50+50/d	100	175	60	80	60/40	6 150kg/1 m3	Type II	AD	Ground	500
Ground Transport	5	15,000	75+100/d	75	125	60	50	40/30	3 10,000kg/30 m3	Type III	AD	Ground	1000
Offroadr	3	5,500	--	150		75		60/30	5 100kg/3 m3		#15-p26	Ground	600
Personal Walker	2	5,250	5	150		75		75/75	2 300kg/2 m3		#15-p26	Ground	550
Snow Cycle	1	1,750	5	100		50		50/25	2 15kg/0.25 m3	Type I	#15-p26	Ground	175
Hovercycle	1	2,000	5	100	175	80	90	100/40	2 20kg/0.5 m3	Type I	AD	Hover	200
Hover Car	2	8,000	50+75/d	150	250	60	70	80/40	6 100kh/1 m3	Type II	AD	Hover	500
Hover Transport	5	20,000	75+150/d	150	250	90	40	60/30	3 10,000kg/35 m3	Type III	AD	Hover	1000
Aircar	3	50,000	100+100/d	900		400		100/100	4 1,000kg/2 m3	Type IV	AD	Air	600
Cargojet	6	120,000	--	1100		550		125/63	4 100,000kg/162 m3	Type IV	#15-p26	Air	1200
Glijet	1	3,000	75+50/d	100		30		30/--	1 15kg/0.1 m3	Rocket Pack (50 Cr)	AD	Air	100
Jetcopter	4	40,000	100+80/d	350		50		100/100	4 500kg/5 m3	Type IV	AD	Air	800
Cargo Ship	6	36,000	--	50		23		20/10	15 20,000ton/300 m3	Type IV	#15-p26	Water	1200
Powerboat	3	6,500	--	100		50		20/10	6 250kg/6 m3	Type I	#15-p26	Water	600
Sub	5	28,000	--	50		25		10/5	10 8,000kg/25 m3	Type III	#15-p26	Water	1500
Skicycle	1	1,300	--	100		50		50/27	2 10kg/0.25 m3	Type I	#15-p26	Water	200
Infiltrator Ground Cycle		4,000	--	120	200	60	100	100/40	2 20 kg, 0.5 cu. m	Type I	#2-p15	Ground	
Manta Mini-Sub		10,000	--	35	60	20	35	10/10	2 50 kg, 1 cu. m	Type III	#8-p54	Water	
Bathyploer		50,000	--	25	45	15	25	7/7	2 100kg, 2 cu. m	Type III	#8-p54	Water	
Personal Runabout*		550,000	Nov-13	900	--	400	--	100/100	6 2,000 kg, 4 cu. m	Type IV	#7-p23	Air/Space	
Skipflyer*		280,000	--	700	--	235	--	--	2-5 12,000 kg, 30 cu. m	Type IV	#7-p23	Air/Space	
Cloud Flyer	4	40,000	200+100/d	400	--	150	--	--	6 3,000 kg, 5 cu. m	Type IV	#16-p66	Air	650
Aero-Flyer	4	76,550	13-15	500		250		150/75	6 3,000 kg, 5 cu. m	Type IV	#16-p66	Air	650
Survey Airship		10,000	16-18	100		50			20 1,000 kg, 100 cu. m		SFKH2	Air	
TSSS Dart*			16	900		400		150			#11-p13	Air/Space	
Sail boat	B	6,000	17	15		10			6 200/1 m3	Type2	#15-p34	Water	
Yacht	C	75,000	18	100		60			10 10,000/35 m3	TwoType4	#15-p34	Water	
Transport ship	D	200,000	18	95		55			10 72,500/24 m3	FourType4	#15-p34	Water	
Passenger ship	D	200,000	19-20	95		55			30 7,500/8 m3	FourType4	#15-p34	Water	
Minisub**	C	50,000	21-26	100/85		60/45			4 300/3 m3	TwoType2	#15-p34	Water	
Transport submarine**	D	20,000	27-38	90/70		50/40			6 50,000/18 m3	FourType4	#15-p34	Water	
Passenger submarine**	D	20,000	27-30	90/70		50/40			20 5,000/5 m3	FourType4	#15-p34	Water	
Amphibious aircar	--	55,000	31-34	875		400			4 750/2 m3	Type4	#15-p34	Water/Air	
Amphibian air transport	--	125,000	34-38	700		250			3-12 9,500/40 m3	TwoType4	#15-p34	Water/Air	
Amphibian jetcopter	--	45,000	39-40	325		50			4 350/5 m3	Type4	#15-p34	Water/Air	
UPF Meteor Class Shuttle*		665,280	--	600		450			24 varies	Type 4	#16-p30	Air/Space	
Shooting Star Class Shuttle*		462,280	--	600		450			24 varies	Type 4	#16-p30	Air/Space	

* Can also function in space. See 'Spaceships' section for Knight Hawks Rules stats.

Vehicles and Transport 2

Car Size Modifiers

Vehicle Type	Top Speed	Cruise Speed	Turn Acceleration	Deceleration	Speed	Passengers	Cargo	Cost(Cr)	Source
Compact	-20	-20	-20	+20	+10	-50%*	-50%	-25% #15-p24	
Intermediate	-10	n/a	-10	+10	n/a	n/a	-25%	-10% #15-p24	
Mid-Sized	n/a	n/a	n/a	n/a	n/a	n/a	n/a	n/a #15-p24	
Large	+10	+10	+10	n/a	-10	+50%**	+50%	+15% #15-p24	
Heavy	n/a	+20	n/a	-10	-20	+100%	+100%	+30% #15-p24	

Car and Cycle Style Modifiers

Vehicle Type	Top Speed	Cruise Speed	5	5	Deceleration	Speed	Special	Cost(Cr)	Source
Standard	n/a	n/a	n/a	n/a	n/a	n/a	n/a	n/a #15-p24	
Cruise	-10 kph	+10%	n/a	n/a	n/a	n/a	n/a	+10% #15-p24	
Utility*	-10 kph	n/a	n/a	n/a	n/a	-10	n/a	+20% #15-p24	
Luxury	n/a	+20 kph	n/a	n/a	n/a	-10	n/a	+25% #15-p24	
Sport	+10 kph	-10 kph	+10	+10	+10	+10	n/a	+40% #15-p24	
SuperSport	+20 kph	-20 kph	+20	+20	+20	+20	n/a	+50% #15-p24	
DualSport	n/a	n/a	+10	-10	-10	+0.1 Terrain		+30% #15-p24	
Adventure	n/a	n/a	n/a	-20	-20	+0.2 terrain		+40% #15-p24	
Vintage/Classic	-10 kph	-10 kph	-10	n/a	-10	n/a		-50 to +500% #15-p24	
Custom**	varies	varies	varies	varies	varies	varies	varies	varies #15-p24	

*Utility vehicles may alternate passenger and cargo space by converting 100kg/1 cubic meter of cargo space to 1 passenger seat.

**Custom variations allow for combinations, such as sport/standard. Use the lesser applicable modifier and average the cost modifiers. Use common sense where applicable, such as a longer wheel base vehicle (chopper or stretch limo) would have a turn speed penalty etc

Transports & Explorers Size Modifiers

Vehicle Type	Top Speed	Cruise Speed	16-18	16	Deceleration	Speed	Special	Cost(Cr)	Source
Small	+10 kph	-10 kph	17	17	+10	+10	-33%	-50% #15-p24	
Standard	n/a	n/a	18	18	n/a	n/a	n/a	n/a #15-p24	
Large	-10 kph	+10 kph	18	18	-10	-10	+33%	+50% #15-p24	
HeavyDuty*	-20 kph	+20 kph	19-20	19-20	-20	-20	+100%	+100% #15-p24	

*TRACK MOBILE chassis available @ +25% costs, (not permitted in city streets).

27-38

Transports & Explorers Style Modifiers

Vehicle Type	Top Speed	Cruise Speed	31-34	34-38	Deceleration	Speed	Special	Cost(Cr)	Source
Sport	+20 kph	-10 kph	39-40	39-40	+10	+10	n/a	-25% #15-p24	
Utility*	n/a	n/a	+10	+10	n/a	n/a	n/a	n/a #15-p24	
Passenger	n/a	n/a	n/a	n/a	+10	n/a	+20	-75% #15-p24	
Cargo	n/a	+10	n/a	n/a	n/a	n/a	-50%	+100% #15-p24	

*Utility vehicles may alternate passenger and cargo space by any combination of 50%/50% (e.g. a standard utility explorer may convert 3 passenger seats to 1000kg/3 cubic meter of cargo space)

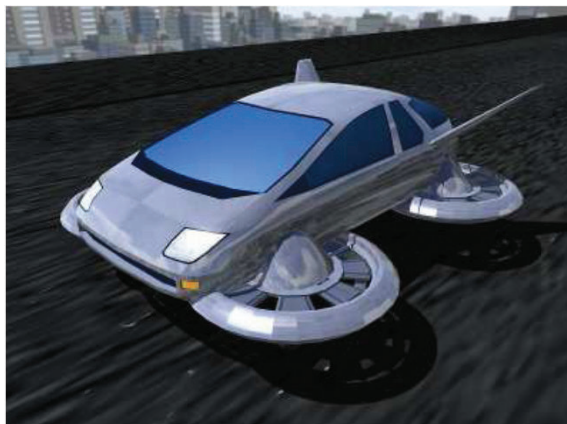

Vehicles and Transport 2

Modifications	Effect	Cost (Cr)	Source
Sidecar (cycles only)	+1 passenger, +50% cargo, -10 accel, decel, turn, speed	500	#15-p24
Detachable Luggage	+50% cargo space	75	#15-p24
Utility Trailer - Cycle	+100% cargo space, -10 accel, decel, turn, top speed for each trailer added	250	#15-p24
Utility Trailer - Car		750	#15-p24
Utility Trailer - Transport		2,500	#15-p24
Air Brakes/Hard Brakes	+10 decel	1,000	#15-p24
Re-gear'd Transaxles	+10 accel, decel -10 top, cruise speed (Choose one) -10 accel, decel & +10 top, cruise speed	500	#15-p24
Gyro Stabilizers	+10 turn speed	2,500	#15-p24
Powerplant Rebuild(10)	+10 accel, decel, turn, top, cruise speeds	15,000	#15-p24
Powerplant Rebuild(20)	+20 accel, decel, turn, top, cruise speeds	25,000	#15-p24
Powerplant Rebuild(30)	+30 accel, decel, turn, top, cruise speeds	35,000	#15-p24
High Performance Racing Chip	+20 accel & top speed, +10 decel & turn speed	20,000	#15-p24

Space Travel	Cost (Cr)	Cargo	Travel Time
Starship Tickets			
First Class	200/LY	1 metric ton	1 ly/day
Journey Class	100/LY	½ metric ton	1 ly/day
Storage Class	30/LY	100 kg	1 ly/day

In System, Shuttles

Planet to Planet

First Class	200	500 kg	2-5 days
Journey Class	100	250 kg	2-5 days
Storage Class	30	50 kg	2-5 days

Planet to Orbit

First Class	100	1000 lkg	2 hours
Journey Class	50	500 kg	2 hours

In System, System Ships

First Class	300	300 kg	1 day
Journey Class	200	200 kg	1 day
Storage Class	60	60 kg	1 day

On Planet

Passenger Airline	250	300 kg	10,000 km/day
Long Range Ship	100	2500 kg	500 km/day
Short Range Ship	25	2500 kg	500 km/day
Long Range Ground	150	150 kg	2000 km/day
Short Range Ground	2+1/km	150 kg	2000 km/day
Monorail	1/day	carry-on	100 m/turn

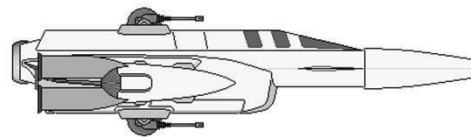
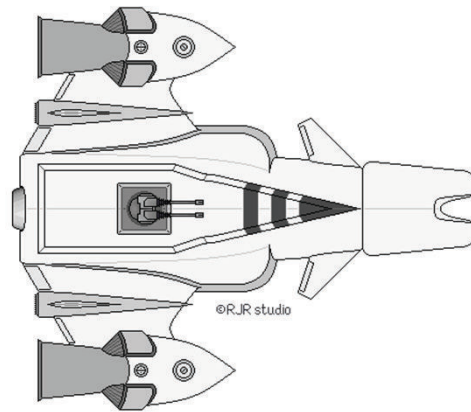
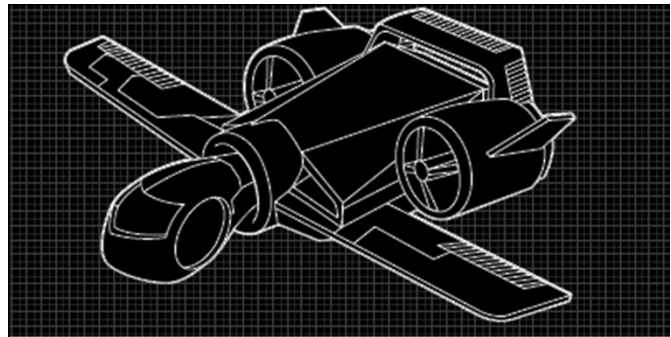

Spaceships

Ship Type	Cost (cr)	Hull						Crew	Cargo	Passengers	Source
		Hull Size	Points	ADF	MR	DCR					
Skipflyer*	280,000		5	2	2	15	1			2-5	#7-p23
	Weapons	none						12,000 kg, 30 cubic meters			
	Defenses	none									
	Equipment	none									
	Engines										
	Ship Vehicles	none									
Liberty-class Patrol Gunship	1,566,734	4	30	7	6	40	14	0.5		0	#7-p23
	Weapons	Laser Cannon x2, Laser Battery x2, Torpedo x2									
	Defenses	Reflective Hull, Masking screen x4, Interceptor Missiles x4									
	Equipment	Subspace radio, VideoCom, Radar, Energy Sensor, Intercom. Reinforced Hull, Cargo Arm									
	Engines										
	Ship Vehicles	lifeboat, 1 small Launch, 1 large Launch, 2 workpods									
Personal Runabout	550,000						1			5	#7-p23
	Weapons	none						2,000 kg, 4 cubic meters			
	Defenses	none									
	Equipment	Type II Generator, Type IV Parabattery x2									
	Engines										
	Ship Vehicles	none									
Eagle Transporter		2					2-6				#8-p51
	Weapons	none						by pod type			
	Defenses	none									
	Equipment	Leven 2 computer (17 function points), Videocom Radio, Radar									
	Engines	1 Chemical									
	Ship Vehicles	none									
East Indiaman Class Medium Transport	1,570,000	10	50	1	3	50	4				#6-p6
	Weapons	Laser Battery									
	Defenses	Reflective Hull									
	Equipment	Atomic Engines									
	Engines										
	Ship Vehicles										
Explorer-class Heavy Scout Craft	2,007,600	5	18	2	1	35	7	optional detactable cargo bin		5	#8-p29
	Weapons	Laser Battery						(50,000 Cr)			
	Defenses	Masking Screen, Reflective Hull									
	Equipment	Level 4 computer									
	Engines	2 class B Atomic Engines									
	Ship Vehicles	Optional Expedition Shuttle									
Expedition Shuttle	125,000	1	31-34	1	1	23	2	optional detactable cargo bin		3-4	
	Weapons	none						(50,000 Cr)			
	Defenses	none									
	Equipment	Level 1 Computer, Shuttle Astrogation Equipment, Videocom Radio, Specialized docking collar									
	Engines	1 Class A Chemical Drive									
	Ship Vehicles	none									
Jump Tug	3,621,100	5	40	6 (1)	6 (1)	35	6				#9-p28
	Weapons	none						Special (system ships)			
	Defenses	Reflective Hull									
	Equipment	Level 4 Computer, Radio w/4 screens, Subspace Radio, Intercom									
	Engines	4 Class C Atomic Engines									
	Ship Vehicles	workpod									
TSSS Dart*		2	10	4	4	26	4-8				#11-p13
	Weapons	Pod Laser Turret									
	Defenses	Reflective Hull									
	Equipment	Videocom radio, Subspace Radio, shipwide intercom,									
	Engines	1 Atomic Engine									
	Ship Vehicles	none									
RT-3100 Merchant Scout		3	15	4	4	30	4-8				#11-p13
	Weapons	Laser Battery						2			
	Defenses	Reflective Hull									
	Equipment	Subspace radio, videoCom, Radar, Intercom, Universal Airlock									
	Engines	2 class A Atomic engines									
	Ship Vehicles	none									

Spaceships

Ship Type	Cost (cr)	Hull						Crew	Cargo	Passengers	Source
		Hull Size	Points	ADF	MR	DCR					
TT-456 Container Ship		4	20	5 (3)	4 (2)	32	8	dependant on cargo containers	-	#13-p22	
Weapons PL											
Defenses Reflective Hull											
Equipment Intercom, Subspace Radio, Radar, Videocom											
Engines 2 Class- B Atomic Engines											
Ship Vehicles Workpod, Small Launch											
S-200 Assault Shuttle		2	12	2	4	26	2	0.5	12	#13-p32	
Weapons PL, PLT											
Defenses Reflective Hull											
Equipment Subspace Radio, Radar, Light Armor											
Engines 2 Class - A Chemical											
Ship Vehicles none											
S-4 Corsair Fighter		1	8	5	4	30	2	0	-	#13-p33	
Weapons PL, PLT											
Defenses Reflective Hull											
Equipment Subspace Radio, Radar, Heavy Armor											
Engines 2 class - A Atomic											
Ship Vehicles none											
Christinna-class Torpedo Frigate		7	35	4	4	70	19	5 units	-	#13-p34	
Weapons RG x2, RGB, (TT x8, or SM x10)											
Defenses RH, MS, IS, AS											
Equipment Intercom, Subspace Radio, Radar, Videocom, White noise broadcaster, energy sensors											
Engines 2 Class C Pion											
Ship Vehicles 1 Launch, 2 workpods, 9 escape pods											
Eleanor Moraes		3		4	3		12			SFKH2	
Weapons 2 Laser Batteries											
Defenses none											
Equipment Videocom, subspace radio, Radiophone, Radar											
Engines 2 Class-A Atomic											
Ship Vehicles 4 lander modules, 2 explorers, 2 airships per lander modules											
Gullwind		6	24	4	3	38	6	6 units	10		
Weapons Laser Battery											
Defenses Reflective Hull											
Equipment Videocom, Intercom, Radar, Skin Sensor, Subspace Radio											
Engines 3 Class- B Atomic											
Ship Vehicles											
UPF Meteor Class Assault Shuttle*	665,282	1	12	2	4	24	2	various by configuration	24	#16-p30	
Weapons none but has mount points											
Defenses Military grade ceramic armor plating											
Equipment RADAR, Videocom, intercom, radiophone, 1/4 power WNB											
Engines 1 Class A Atomic Engine											
Ship Vehicles											
Shooting Star Class Shuttle*	462,280	1	7	2	4	23	2	various by configuration	24	#16-p30	
Weapons none											
Defenses Military grade ceramic armor plating											
Equipment RADAR, Videocom, intercom, radiophone, 1/4 power WNB											
Engines 1 Class A Atomic Engine											
Ship Vehicles											
CMS Osprey		3	14	5	4	59	12			SGKH3	
Weapons Laser Battery, 4 Assault Rockets											
Defenses Reflective Hull											
Equipment Videocom, Subspace Radio, Radar, Energy Sensor											
Engines 2 class - A Atomic											
Ship Vehicles											

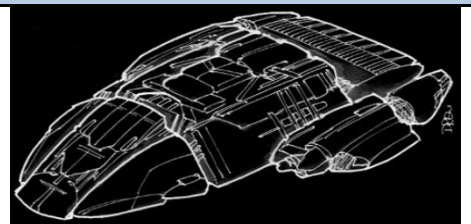
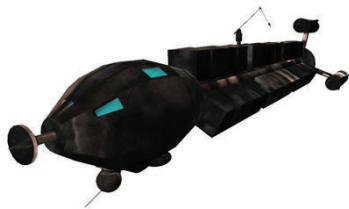

Space-Faring Races

Race Name	Type	Lifespan	Temp	STR/STA	DEX/RS	INT/LOG	PER/LDR	Movement	Special Abilities	Source
Aleerin	Cybernetic	250 yrs	37 C	+5	0	+5	-10	10 m/t 30 m/t	Computer Skill Bonus - +10 bonus to all computer sub-skills.	SFman #7-p3
	Humanoid							5 kph		
	Reproduction	Size	Average Stats					Hourly		
	Heterosexual	1.8 m tall	50/50	45/45	50/50	35/35				
	tank-grown	90 kg	IM: 5	PS: +3						
			ATT: 23							

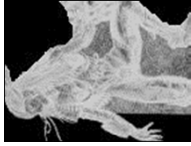

Arborean	Bipedal	5	5	STR/STA	DEX/RS	INT/LOG	PER/LDR	Movement	Special Abilities	Source
	Avian	5	5	-10	+5	+5	0	5 m/t 20 m/t	Comprehension - 5%, as Vrusk	SFman #6-p19
	Reproduction	Size	Average Stats					Hourly		
	Heterosexual	1.2 m tall	35/35	50/50	50/50	45/45				
	Ovoviviparous	2.5 m wingspan	IM: 5	PS: +2					Sharp Eyesight - range penalties are ½	
		25 kg	ATT: 25						Gliding - glide on air currents.	



Boon'sheh	Hairless	75 yrs	39 C	STR/STA	DEX/RS	INT/LOG	PER/LDR	Movement	Special Abilities	Source
	Humanoid	39 C	39 C	-10	+10	0	0	20 m/t 40 m/t	Danger Sense - 10% chance to be aware of impending danger.	SFman #3-p30
	Reproduction	Size	Average Stats					Hourly		
	Heterosexual	2.0 m tall	35/35	55/55	45/45	45/45				
	Viviparous	55 kg (m) 60 kg (f)	IM: 6	PS: +2						
			ATT: 28							

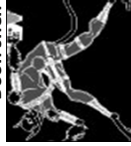





Bora-Kai	Grey-skinned	80 yrs (m) 120 yrs (f)	13-15	STR/STA	DEX/RS	INT/LOG	PER/LDR	Movement	Special Abilities	Source
	Humanoid	80 yrs (m) 120 yrs (f)	13-15	+10	-5	-5	0	5 m/t 20 m/t	Night Vision - can see in low light.	SFman #2-p20
	Mammal							5 kph		
	Reproduction	16-18	Average Stats					Hourly		
	Heterosexual	16	55/55	40/40	40/40	45/45				
	Viviparous	17	IM: 4	PS: +3					Durability - Current STA max is +5 (does not change STA ability)	
		18	ATT: 20							
		18								



Clikk	6-limbed insectoid	19-20	21-26	STR/STA	DEX/RS	INT/LOG	PER/LDR	Movement	Special Abilities	Source
	(4 legs, 2 arms)	19-20	21-26					5 m/t 20 m/t	Multiple - see Sfman issue #16-p3 for more information	Sfman #16-p3
	Reproduction	27-38	Average Stats					Hourly		
		27-30	70/70	60/50	25/25	20/20				
		31-34	40/40	50/60	60/60	45/45				
		34-38	IM: 20	PS: +3						
		39-40	ATT: 20							

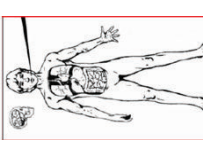

Space-Faring Races

Race Name	Type	Lifespan		Ability Scores			Movement			Special Abilities	Source	
		Temp	250 yrs	STR/STA	DEX/RS	INT/LOG	PER/LDR	Walk	Run			5 m/t
	Amorpheus	30 C	+5	0	-5	0	0	0	0	5 m/t	20 m/t	Alpha Dawn
	Reproduction	Size	Average Stats			Hourly						
	Hermaphroditic	1.3 m tall	50/50	45/45	40/40	45/45						
	Budding	1.0 m wide	IM: 5	PS: +3								
		65 kg	ATT: 23									
Lie Detection - 5% chance of success.												
	Furry Dinosaur	220 yrs	+10	-10	+5	-5	15 m/t	35 m/t	6 kph	15 m/t	35 m/t	SFman #8-p19
	Reproduction	Size	Average Stats			Hourly						
	Heterosexual	1.9 m tall	55/55	35/35	50/50	40/40	Swim	15 m/t	2 kph			
	Ovoviviparous	120 kg	IM: 4	PS: +3								
			ATT: 18									
Genetic Protection - Any Voluturnus race must pass LOG to attack. +20% interactions												
Leaping & Vaulting - can leap 1.5x normal.												
Mentalism - Hypnotisim (or Telepath).												
	Slender Humanoid	200 yrs	-5	-5	+5	+5	10 m/t	30 m/t	5 kph	10 m/t	30 m/t	SFman #7-p5
	Reproduction	Size	Average Stats			Hourly						
	Heterosexual	1.5 m tall	40/40	40/40	50/50	50/50						
	Viviparous	55 kg	IM: 4	PS: +2								
			ATT: 20									
Read Thoughts - 10% sense surface thoughts. Range 2 m/10%												
Send Thoughts - Up to 50 words automatic. Over 50, roll on Read Thoughts ability.												
	Large Ape-like Mammal	100 yrs	+20	0	-20	0	10 m/t	30 m/t	5 kph	10 m/t	30 m/t	SFman #8-p55
	Reproduction	Size	Average Stats			Hourly						
	Heterosexual	2.5 m tall	65/65	45/45	25/25	45/45						
	viviparous	120 kg (m)	IM: 5	PS: +4								
		110 kg (f)	ATT: 23									
Tracking Ability - 40% by smell. Can be raised with XP.												
Incredible Strength - no penalties on high G planets.												
	Upright Primate Mammal	200 yrs	0	0	0	0	10 m/t	20 m/t	5 kph	10 m/t	20 m/t	Alpha Dawn
	Reproduction	Size	Average Stats			Hourly						
	Heterosexual	1.9 m tall	45/45	45/45	45/45	45/45						
	Viviparous	80 kg (m)	IM: 5	PS: +3								
		55 kg (f)	ATT: 23									
Adaptable - +5 to any single stat.												

Space-Faring Races

Race Name	Type	Lifespan		Ability Scores			Special Abilities		Source
		Temp	STR/STA	DEX/RS	INT/LOG	PER/LDR	Movement	Abilities	
Kurabanda	Primate	120 yrs	0	+5	0	+5	10 m/t	Mental Shield - +10% resistance to mental control or attacks. Immune to Sathar hypn	SFman #7-p17
	Mammal	38 C	0	+5	0	+5	30 m/t		
	Reproduction	Size	Average Stats			Hourly	4 kph		
	Heterosexual	1.2 m tall	45/50	50/50	45/45	50/50			
	Viviparous	45 kg	IM: 5	PS: +3					
			ATT: 25						
								Climbing - Climb at 5 m/t. +10% to climbing checks.	



Laamvin Furry		STR/STA	DEX/RS	INT/LOG	PER/LDR	Walk	Run	Sfman
Crustacean		0/+25	0/+15	0	0	20 m/t	45 m/t	#16-p1
Reproduction	Size	Average Stats			Hourly	8 km		
Tri-Sexual	1 m tall	45/70	45/60	45/45	45/45			
Ovoviviparous		IM: 6	PS: 3					
		ATT: 23						
								Carapace - +25 to STA

Mechanon Warrior		STR/STA	DEX/RS	INT/LOG	PER/LDR	Walk	Run	SFman
Mechanon	225 yrs	+15	+10	0	-10	8 m/t	25 m/t	#8-p62
Warrior	42 C					4 kph		
Reproduction	Size	Average Stats			Hourly			
Parthenogenesis	2.8 m tall	60/60	55/55	45/45	35/35			
	120 kg	IM: 6	PS: +3					
		ATT: 28						
								Multiple - See Star Frontiersman Issue #8 P. 66 for full details.



Mechanon Thinker		STR/STA	DEX/RS	INT/LOG	PER/LDR	Walk	Run	SFman
Mechanon	225 yrs	-10	0	+10	+15	8 m/t	25 m/t	#8-62
Thinker	42 C					4 kph		
Reproduction	Size	Average Stats			Hourly			
Parthenogenesis	3 m tall	35/35	45/45	55/55	60/60			
	100 kg	IM: 5	PS: +2					
		ATT: 23						
								Multiple - See Star Frontiersman Issue #8 P. 66 for full details.

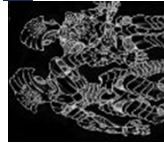

Nagana		STR/STA	DEX/RS	INT/LOG	PER/LDR	Walk	Run	SFman
Serpent-like	125 yrs	-5	+5	-5	+5	10 m/t	20 m/t	#1-p10
amphibious	29 C					3 kph		
Reproduction	Size	Average Stats			Hourly			
Hetrosexual	1.8 m Tall	40/40	50/50	40/40	50/50			
viviparous	60 kg	IM: 5	PS: +2					
		ATT: 25						
								Amphibious - Can breath under water.
								UltraSonic Communication - Can speak & hear in ultrasonic range.



Space-Faring Races

Race Name		Lifespan		Ability Scores			Special		Source
Type	Temp	STR/STA	DEX/RS	INT/LOG	PER/LDR	Movement	Abilities		
Robot PC's robotic	varies	+10	+5	+5	-20	10-35 m/t 30-125 m/t	Programs & Equipment	SFman #6-p1	
Reproduction	Size	Average Stats			Hourly				
Construction	varies	55/55	50/50	50/50	25/25	depends on type			
		IM: 5	PS: 3						
		ATT: 25							



Sathar	Serpent-like reptile	unknown	-5	0	+10*	10 m/t 20 m/t 3 kph	Hypnotism - in non-combat only, target must make a LOG check.	Alpha Dawn
Reproduction	Size	Average Stats			Hourly			
unknown	3.5 m long 55 kg	40/40	40/40	45/45	40/60			
		IM: 4	PS: 2					
		ATT: 20						



Saurians	Bipedal Reptilian humanoid	240 yrs	-10	0	0	10 m/t 30 m/t 5 kph	Caution - +15% resistance to hypnotism or mind control.	Dragon Mag#103
Reproduction	Size	Average Stats			Hourly			
Heterosexual	2.1 m tall 100 kg (m) 90 kg (f)	55/55	35/35	45/45	45/45			
		IM: 4	PS: 3					
		ATT: 18						



Scree	Bipedal Plant	320 yrs	-10	+10	-20	10 m/t 20 m/t 3 kph	Alien Lore - able to determine the function of alien artifacts and origins.	SFman #9-p11
Reproduction	Size	Average Stats			Hourly			
Hermaphroditic	2.3 m tall 65 kg	50/50	35/35	55/55	25/25			
		IM: 4	PS: 3					
		ATT: 18						



Sesheyen	Winged reptilian	150 yrs	+5	0	-5	10 m/t 30 m/t 4 kph	Night Vision - Able to see in low light. -15% all actions in bright light.	SFman #7-p7
Reproduction	Size	Average Stats			Hourly			
	1.7 m tall 40 kg	45/45	50/50	45/45	40/40			
		IM: 5	PS: 3					
		ATT: 25						

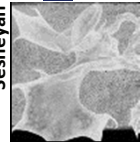

Flight - same move rates on land or in air.

Technophobia - -10% all technological skills.

Space-Faring Races

Race Name	Type	Lifespan		Ability Scores			Special Abilities		Source
		Temp	Size	STR/STA	DEX/RS	INT/LOG	PER/LDR	Movement	
S'sessu	Serpent-like reptile	150 yrs	39 C	-5	+5	-5	+5	15 m/t	SFman #7-p9
		3.5 m long	55 kg	45/45	55/55	35/35	3 kph		
	Reproduction	0		0	+10	-10			
	Heterosexual	IM:	5	PS:	+3				
	viviparous	ATT:	23						



Race Name	Type	Lifespan		Ability Scores			Special Abilities		Source
		Temp	Size	STR/STA	DEX/RS	INT/LOG	PER/LDR	Movement	
T'sa	Lithic reptilian	150 yrs	39 C	-5	+5	-5	+5	15 m/t	SFman #7-p9
		1.4 m tall	23 kg	40/40	50/50	40/40	50/50	6 kph	
	Reproduction	0		0	+10	-10			
	Heterosexual	IM:	5	PS:	+2				
	ovoviviparous	ATT:	25						

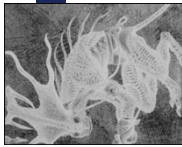

Race Name	Type	Lifespan		Ability Scores			Special Abilities		Source
		Temp	Size	STR/STA	DEX/RS	INT/LOG	PER/LDR	Movement	
Ul-Mor	9-limbed cephalopods	150 yrs	38 C	-5	+5	+5	-5	5 m/t	Mind Link - Direct mind communication with a willing recipient
		1 m tentacles	.75 m body	40/40	50/50	50/50	40/40	3 kph	
	Reproduction	0		0	+10	-10			
	Heterosexual	IM:	5	PS:	+2				
	Ovoviviparous	ATT:	25						





Race Name	Type	Lifespan		Ability Scores			Special Abilities		Source
		Temp	Size	STR/STA	DEX/RS	INT/LOG	PER/LDR	Movement	
Vimh	Rodent-like Mammal	60 yrs	39 C	+20	+5	0	-10	10 m/t	Iron Constitution - 5% resist poison, disease, etc SFman #5-p35
		1.9 m (straight)	70 kg	65/65	50/50	45/45	35/35	5 kph	
	Reproduction	0		0	+10	-10			
	Heterosexual	IM:	5	PS:	+4				
	Viviparous	ATT:	25						

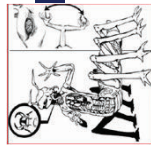

Race Name	Type	Lifespan		Ability Scores			Special Abilities		Source
		Temp	Size	STR/STA	DEX/RS	INT/LOG	PER/LDR	Movement	
Vrusk	multi-limbed insect	175 yrs	38 C	-5	0	+5	0	15 m/t	Ambidexterity - Can use either hand equally. Alpha Dawn
		1.5 m tall	85 kg	40/40	45/45	50/50	45/45	6 kph	
	Reproduction	0		0	+10	-10			
	Heterosexual	IM:	5	PS:	+2				
	Ovoviviparous	ATT:	23						

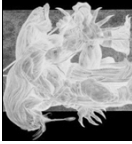
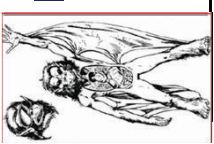

Space-Faring Races

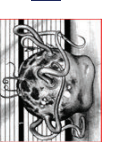
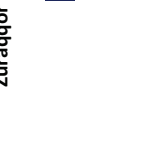
Race Name		Type	Lifespan		Ability Scores			Movement		Special	Source
		Temp	STR/STA	DEX/RS	INT/LOG	PER/LDR	Walk	Run	Abilities		
	Weren	Massive	250 yrs								SFman
		humanoid	38 C	+10	-5	0	-5	30 m/t	Claws - 1d10 Inertia damage.		#7-p11
		Reproduction	Size	Average Stats			Hourly		Camouflage - -10% to be hit if move less 2m/t		
		Heterosexual	2.2 m tall	55/55	40/40	45/45	40/40		Night Vision - Able to see in low light. -15% all actions in bright light.		
	Viviparous	180 kg	IM: 4	PS: +3							
			ATT: 20								
	Yazarian	winged Primate	140 yrs								Alpha
		Mammal	39 C	-10	+5	+5	0	30 m/t	Night Vision - Able to see in low light. -15% to DEX/RS in bright light.		Dawn
		Reproduction	Size	Average Stats			Hourly		Gliding - Glide 1 m ahead for each meter descended.		
		Heterosexual	2.1 m tall	35/35	50/50	50/50	45/45		Battle Rage - 5% chance. +20% to hit in melee.		
	Viviparous	50 kg (m)	IM: 5	PS: +2							
		60 kg (f)	ATT: 25								
	Yinni	Small, winged	25 yrs								SFman
		Bipeds	21 C	-20	+10	+5	+5	5 m/t	Flight - Can fly without tiring. Can carry STR/5 at full speed, STR/3 at half speed.		#4-p33
		Reproduction	Size	Average Stats			Hourly		Scent - Can identify by Scent alone. Can track by scent.		
		Sexual	25 cm	25/25	55/55	50/50	50/50	1 kph			
	Larviparous	50 cm wingspan	IM: 6	PS: +2							
		2.2 kg	ATT: 28								
	Zethra	Spherical	400+ yrs								Dragon
		amorpheous	34 C	-10	+5	+5	-10	15 m/t	Multiple - See Star Frontiersman Issue # 13 p. 13.		Mag# 84
		Reproduction	Size	Average Stats			Hourly				
		Hermaphroditic	1.5 m diameter	35/35	50/50	50/50	35/35	6 kph			
		budding	7.5 m tip to tip	IM: 5	PS: +2						
		60 kg	ATT: 25								
	Zuraqqor	Bipedal Insects	Unknown								Omicron
		Unknown	Unknown	-15	+15	-10	-15	10 m/t	Unknown		Mini-Mod
		Reproduction	Size	Average Stats			Hourly				
		Heterosexual	30/30	60/60	35/35	30/30	30/30	5 kph			
	Larviparous	(hive)	IM: 6	PS: +2							
			ATT: 30								

Planets

System Name	Planet Name	Type	Diameter	Orbital Radius	Local Year	Gravity	Local Day	Population
Araks System								
G4 V Yellow Main Sequence								
Araks I	Jovian			0.31 AU	0.18 Std Yrs	2.76		
Araks II	Jovian			0.61 AU	0.53 Std Yrs	2.72		
Araks III (Hentz)	Terrestrial			1.49 AU	1.99 Std Yrs	0.7		
Araks IV	Rock Planet			7.36 AU	11.26 Std Yrs	2.04		
Athor System								
K2 Orange Main Sequence								
Athor I (Yast)		5		0.541 AU	167.93 Std Days	0.99	15 hr Light, 90% Yazirian	
Athor Ia (Exib)		5				0.74	37.8 Hrs Moderate, 90% Yazarian	
Athor Ib (Iime)		5				0.28		
Athor II	Ice planet			1.7 AU	538.5 Std Days	1.21		
Athor III	Sub-Jovian			3.3 AU	3406.03 Std Days	--		
Athor IV (Srah)	Jovian			6.5 AU	43562.49 Std Days	--		
Athor IVa (Jik)	airless rock					0.34		
Athor IVb (Ezvoe)	airless rock					0.45		
Athor IVc (Faan)	airless rock					0.34		
Athor IVd (Spe)	airless rock					0.33		
Belnafaer System								
Venturi	Blue							
Snobol	Gas Giant		129,000 km				10 Hrs none	
Wun Era	ice moon		6 km		38 Std Days*		4 min 45 sec	
Tor								
Gerand								
Zix	Nov-13							
Cassidine								
Orange-Yellow								
Rupert's Hole						.9	20 Hrs Medium, mostly Human	
Triad	13-15					1.1	30 Hrs Heavy, mixed	
Dixon's Star	16-18							
Laco	16		6,625 km			1.395	59 Hrs, 52 min 68,000 mostly human	
Dramune System								
Close Reach	17							
Inner Reach	18							
Day High	19-20		8,892 km			0.8101	20 Hrs Mixed (mostly Dra) 500 Million	
Outer Reach	21-26		13,045 km			1	35 Hrs 20 Million	
Diamond	27-38						33 Std Days*	
Shadow	27-30						60 Std Days*	
Three Sisters A	31-34						18 Std Days*	
Three Sisters B	34-38						18 Std Days*	
Three Sisters C	39-40						18 Std Days*	
Lost Reach								
Fromeltar								
Yellow								
Groth						1.2	45 Hrs Light, mostly Dralasisite	
Terledrom						1.0	60 Hrs Heavy, Dralasisite/Vrusk	

Planets

System Name	Planet Name	Type	Diameter	Orbital Radius	Local Year	Gravity	Local Day	Population
FS#30		Yellow						
	Snowball	covered in ice sheets	12,000			0.924	32 Hrs	
	Akhala						23 days*	
Gruna-Garu System		G8 V Yellow Main Sequence	0.66 Sol					
	Gruna-Garu I (Hargut)	Terrestrial		0.82 AU	349.16 Std Days	1.1	19.5 Hrs	High Density, 92% Yazirian
	Gruna-Garu Ia (Trefom)	rock, tidally locked				0.25		Light, Yazirian
K'aken-Kar		Red-Orange						
	Ken'zah Kit					0.9	25 Hrs	Moderate, predominatly Vrusk
Kizk'-Kar		Yellow						
	Zik-kit					1.0	65 Hrs	Moderate, predominatly Vrusk
Madderly's Star		Yellow-Green						
	Kdikit					1.0	30 Hrs	Moderate, predominatly Human
Ora System		M2V Red	0.52 Sol					
		F2V Yellow	1.46 Sol					
	Anthros	Hot rock		0.08 AU				
	Cyprust	Terrestrial, hydrogen lake		0.11 AU		0.9	2,478 Hrs	
	Ora Thei	Ice Giant	5.25	0.22 AU		3.2		
	Quintus	Terrestrial	0.91			0.8	20 Hrs	
	Capernia	Ice Giant (ammonia/methane)	2.2	1.27 AU		4.75		
	Ethlo-I	airless rock		4.56 AU				
	Ethlo-II	airless rock	0.38	4.56 AU		0.7		
Prenglar System		F9 White Main Sequence	1.10 Sol					
	Prenglar I (Aurora)	Rocky desert, hot	7,000 km	0.3 AU	119 Std Days, 60.71 local days	0.61	49 Hrs	
	Prenglar II	airless rock	2,000 km	0.44 AU	281 Std Days, 75.54 local days	0.13	93 Hrs	
	Prenglar III	Jovian	64,000 km	0.67 AU	494 Std Days, 363.24 local days	3.12	34 Hrs	
	Prenglar IIIa	airless rock						
	Prenglar IIIc	airless rock						
	Prenglar IV (Morgaine's World)	Terrestrial, arid, ringed	16,700 km	1.06 AU	223 Std Days, 138.38 local days	1.5	40 Hrs	Mostly human approx 5.2 Billion
	Prenglar V (Gran Quivera)	Terrestrial	12,500 km	1.35 AU	375 Std Days, 625 local days	1	15 Hrs	Heavy mixed (approx 16.35 Billion)
	Grey							
	Gold							
	White							
	Black							
	Prenglar VI	Icy planetoid	2,000 km	2.16 AU	631 Std Days, 1434 local days	0.05	11 Hrs	
	Prenglar VII	Sub-Jovian	15,000 km	3.24 AU	405 Std Days, 142.6 local days	0.47	71 Hrs	
	Prenglar VIII	Sub-Jovian	23,000 km	5.1 AU	680 Std Days, 186.81 local days	0.18	91 Hrs	
	Prenglar IX	Rocky desert, cold	14,000 km	7.16 AU	752 Std Days, 400 local days	0.88	47 Hrs	
Rhianna System		Yellow						
	Alcazzar	Terrestrial, Tidally locked			10,000 hrs	0.81	4,000 Hrs	no permanent colony

Planets

System Name	Planet Name	Type	Diameter	Orbital Radius	Local Year	Gravity	Local Day	Population
Scree Fron		K7 Orange Main Sequence	0.94 Sol					
	Scree Fron I (Hyn)	Rock Planetoid		0.53 AU	149 Std Days	0.48	Small UPF outpost	
	Scree Fron II (Hakosoar)	Terrestrial (thin atmosphere)		0.84 AU	295 Std Days	0.94	50 Hrs Light, 83% Yazirian	
	Scree Fron III (Inti)							
	Scree Fron IV (Infri)							
	Scree Fron V (Halol)	Gas Dwarf		1.335 AU	632.23 Std Days			
	Scree Fron VI (Histran)	airless rock		1.78 AU	909 Std Days	0.59	25 Hrs Outpost, 85% Yazirian	
	Scree Fron VII (a-g)	airless rock						
Sundown System		Orange						
	Sundown I (Sigis)	Terrestrial	25,512 km	0.3 AU	57.5 days	0.7		
	Sundown II (a-u)	airless rock	0.001 to 0.6			nil - 0.5		
	Sundown III (Rimini Belt)	asteroid belt		0.7 AU	205 days			
	Starmist	Terrestrial	9,880 km	1.2 AU	460 days	0.93	21 Hrs	
	Sundown IV (Kirchgoens)	Jovian		2.7 AU	1552.79 days	2.6		
	Sundown V (IVa - al)	airless rock	0.03 to 0.6			nil - 0.5		
	Sundown VI (Giessen)	Jovian		5.1 AU	4031.1 days	2.3		
	Sundown VII (Va- ax)	airless rock				nil - 0.5		
	Sundown VIII (Wetzlar)	airless rock						
	Sundown IX (Lahn Belt)	asteroid belt		9.6 AU	10,410.58 days			
	Sundown X (Tubingen)	terrestrial		18.4 AU	27,624.52 days	0.4		
	Sundown XI (Ayers)	airless rock						
	Sundown XII (c)	airless rock				nil - 0.7		
	Sundown XIII (Schloss)	Dwarf Planetoid		36 AU	75,600 days	2.2		
	Sundown XIV (Sturm)	airless rock				0.8		
	Sundown XV (Thuringia)	Terrestrial		76.8 AU	235,564,51 days	1.3		
	Sundown XVI (IXa - c)	airless rock	0.15 to 0.28			nil - 0.4		
	Sundown XVII (Butzbach)	Jovian Ice		149.5 AU	639,778.78 days	4.65		
	Sundown XVIII (a - al)	airless rock				nil - 0.7		
Theseus		Yellow-Orange G1 V	1.01 Sol					
	Theseus I (Icarus)	rocky desert		0.3 AU				
	Theseus II (Daedalus)	Gas Giant		0.8 AU				
	Minotaur	Terrestrial	13,000 km	1.2 AU	439 days (702 local)	1.2	15 Hrs 8.6 Billion (90% human)	
	Naxos Asteroid Field	asteroid belt		2.2 AU				
	Theseus IV (Ariadne)	Glacial Desert		4 AU				
	Theseus V (Medea)	rocky chunk		6.1 AU				
	Theseus VI (Hecale)	rock		8 AU				
	Theseus VII (Pallas)	Sub-Jovian		9.1 AU				
	Theseus VIII (Pasiphae)	iceball		11.2 AU				
	Theseus IX (Oedipus)	rocky desert		14 AU				
Timeon		Green-Yellow						
	Lossend					.7	70 Hrs Light, predominatly Human	

Planets

System Name	Planet Name	Moon Name	Type	Diameter	Orbital Radius	Local Year	Gravity	Local Day	Population
Tristkar System									
	Denzart		uninhabitable, scorched						
	Kraatar		mountainous, desert	9800 km		272 Std Days	0.6	18 Hrs Medium	60% human, 38% Vrusk
	Tivalla		moon of Kraatar	1200 km	close		0.2		
	Setarz		moon of Kraatar	120 km	far		neg		
	Tridar		Gas Giant						
Truane's Star									
			Orange-Yellow				.9	55 Hrs Moderate, mixed	
	NewPale						1.4	20 Hrs Light, predominatly Human	
Waller Nexus Federation									
			Yellow				0.98007	23 Hrs, 57 min none	
	Mahg Mar		tropical, temperate, arctic zones	12,350 km					
White Light System									
			Red-Orange				0.9973	50 Hrs 5 min even mix, approx 240 Million	
	Clarion (Gollywog)		Terrestrial, wet	11,679 km					
Zebulon System									
			Yellow				1.0013	24 Hrs, 3 min	
	Volturnus		Hot terrestrial	12,895 km				3 days*	
	Leo							27 hours*	
	Lulu								

* moon days is time to orbit it's parent planet

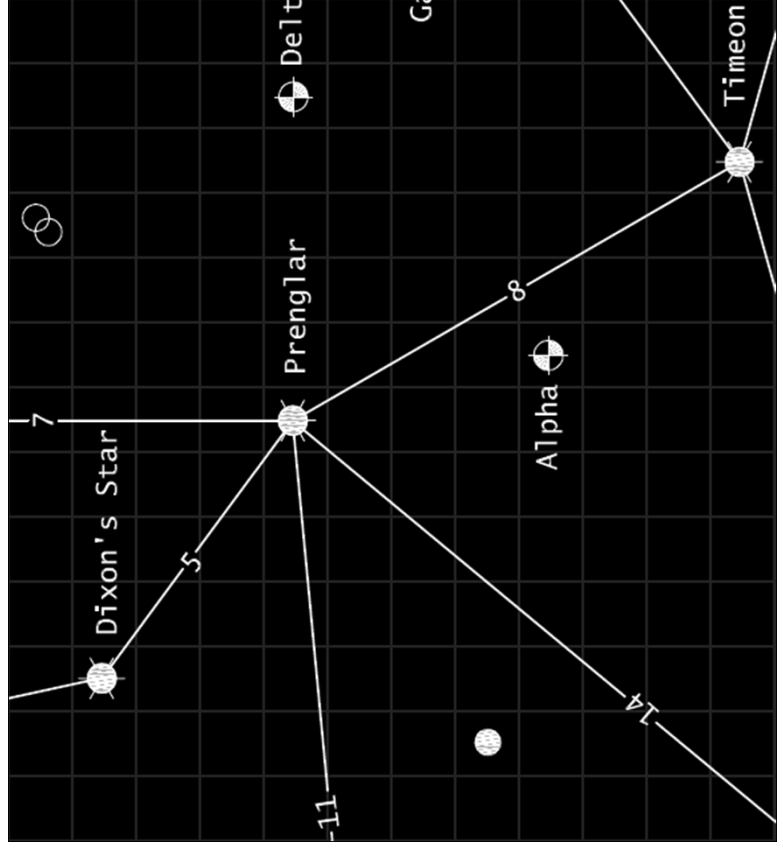

Planets

System Name	Planet Name	Hydrosphere	Atmosphere	Climate	Trade/Economy	Government
Araks System	Moon Name					
	Araks I					
	Araks II					
	Araks III (Hentz)					Theocracy
	Araks IV					
Athor System						
	Athor I (Yast)	12% (ice)	Thin, breathable	-67 C to +54 C	Various	Democracy
	Athor Ia (Exib)	81.60%	breathable	-30 C to 44 C, Avg 8.6 C	Agriculture	Democracy
	Athor Ib (Iime)					
	Athor II					
	Athor III	none	ammonia			
	Athor IV (Srah)					
	Athor IVa (Jik)					
	Athor IVb (Ezvoe)					
	Athor IVc (Faan)					
	Athor IVd (Spe)					
Belnafaer System						
	Venturi	gas	gas	-180 C	--	none
	Snobol	dry ice	none	-140 C		
	Wun Era					
	Tor					
	Gerand					
	Zix					
Cassidine						
	Rupert's Hole				Industrial/Agricultural	
	Triad				Industrial	
Dixon's Star						
	Laco		56% N, 24% O, 1% A, 16% CO2	Avg 70 C (equator), 45 C (poles)	Industry	negligible
Dramune System						
	Close Reach					
	Inner Reach		70% N, 21% O	Avg 29 C	food products	Republican Democracy
	Day High					
	Outer Reach		77% N, 15% O	Avg -4 C	weapons and robots, IxioI	corperate dictatorship
	Diamond					
	Shadow					
	Three Sisters A					
	Three Sisters B					
	Three Sisters C					
	Lost Reach					
Fromeltar						
	Groth				Agricultural	
	Terledrom				Industrial	Vrusk Corporate Council

Planets

System Name	Planet Name	Moon Name	Hydrosphere	Atmosphere	Climate	Trade/Economy	Government
FS#30	Snowball	Akhala		80% N, 17% O	-150 C (poles), +5 C equator		
Gruna-Garu System	Gruna-Garu I (Hargut)	Gruna-Garu Ia (Trefom)	81.70%	breathable	-8.7 C to +32.4 C. Avg 12.4 C	Various	Democracy (by physical ability)
K'aken-Kar	Ken'zah Kit					Agricultural	
Kizk'-Kar	Zik-kit					Industrial/Resource	
Madderly's Star	Kdikit					Industrial/Agricultural	
Ora System	Anthros						
	Cyprust		75%	Moderately toxic	Ave +22 C		
	Ora Thei						
	Quintus		74% (5% ice)		Avg +18 C		
	Capernia						
	Ethlo-I						
	Ethlo-II						
Prengrlar System	Prengrlar I (Aurora)		0%	thin			
	Prengrlar II		0%	none			
	Prengrlar III						
	Prengrlar IIIa						
	Prengrlar IIIc						
	Prengrlar IV (Morgaine's World)		20% (0.12% ice)	76% N, 13% O, 1% CO2	Warm and arid	various business & industry	Representative
	Prengrlar V (Gran Quivera)		60% (9.6% ice)	73% N, 18% O, 2% CO2	varied w/large temperate areas	heavy business & industry	Representative
	Grey						
	Gold						
	White						
	Black						
	Prengrlar VI						
	Prengrlar VII						
	Prengrlar VIII						
	Prengrlar IX						
Rhianna System	Alcazzar		2/3 water	75% N, 20% O	-30 C to +40 C	mining	Corporate

System Name	Planet Name	Hydrosphere	Atmosphere	Climate	Trade/Economy	Government
Scree Fron						
	Scree Fron I (Hyn)					
	Scree Fron II (Hakosoar)	78.90%	Thin, breathable	-22 C to +58C, Avg 21 C	Various	Board of Directors
	Scree Fron III (Inti)					
	Scree Fron IV (Inf)					
	Scree Fron V (Halol)					
	Scree Fron VI (Histran)	0%	none	vacuum	--	Militocracy
	Scree Fron VII (a-g)					
Sundown System						
	Sundown I (Sigis)					
	Sundown II (a-u)				mining	
	Sundown III (Rimini Belt)					
	Starmist		70% N, 24% O	Cool. Warm to frigid. Avg 5 C		
	Sundown IV (Kirchgoens)		80% H, 20% He			
	Sundown V (a - al)					
	Sundown VI (Giessen)		45% H2O, 15% Amm, 40% Meth			
	Sundown VII (Va - ax)					
	Sundown VIII (Wetzlar)					
	Sundown IX (Lahn Belt)					
	Sundown X (Tubingen)					
	Sundown XI (Ayers)					
	Sundown XII (b-c)					
	Sundown XIII (Schloss)					
	Sundown XIV (Sturm)					
	Sundown XV (Thuringia)					
	Sundown XVI (Xa - c)					
	Sundown XVII (Butzbach)		10% H2O, 30% Amm, 60% Meth			
	Sundown XVIII (Xa - al)					
Theseus						
	Theseus I (Icarus)					
	Theseus II (Daedalus)					
	Minotaur	70%	74% N, 17% O, 2% H2O, trace	cool, temperate forests	Industrial	Constitutional Oligarchy
	Naxos Asteroid Field					
	Theseus IV (Ariadne)					
	Theseus V (Medea)					
	Theseus VI (Hecale)					
	Theseus VII (Pallas)					
	Theseus VIII (Pasiphae)					
	Theseus IX (Oedipus)					
Timeon						
	Lossend					Industrial

System Name	Planet Name	Moon Name	Hydrosphere	Atmosphere	Climate	Trade/Economy	Government
Tristkar System							
	Denzart						
	Kraatar	20%	thin		Avg 20%		
	Tivalla	0%	none				
	Setarz	0%	none				
	Tridar						
Truane's Star							
	Pale					Industrial/Resource	
	NewPale					Agricultural	
Waller Nexus Federation							
	Mahg Mar		75% N, 22% O - mild toxins		-20 C to +25 C	none	none
White Light System							
	Clarion (Gollywog)		60% N, 24% O, 16% CO2		Avg 30 C	mineral/petroleum/trade centre	Capitalist Monarchy
Zebulon System							
	Volturnus		78% N, 21% O, 1% A		Hot, arid to humid, Avg 25 C		
	Leo						
	Lulu						

* moon days is time to orb

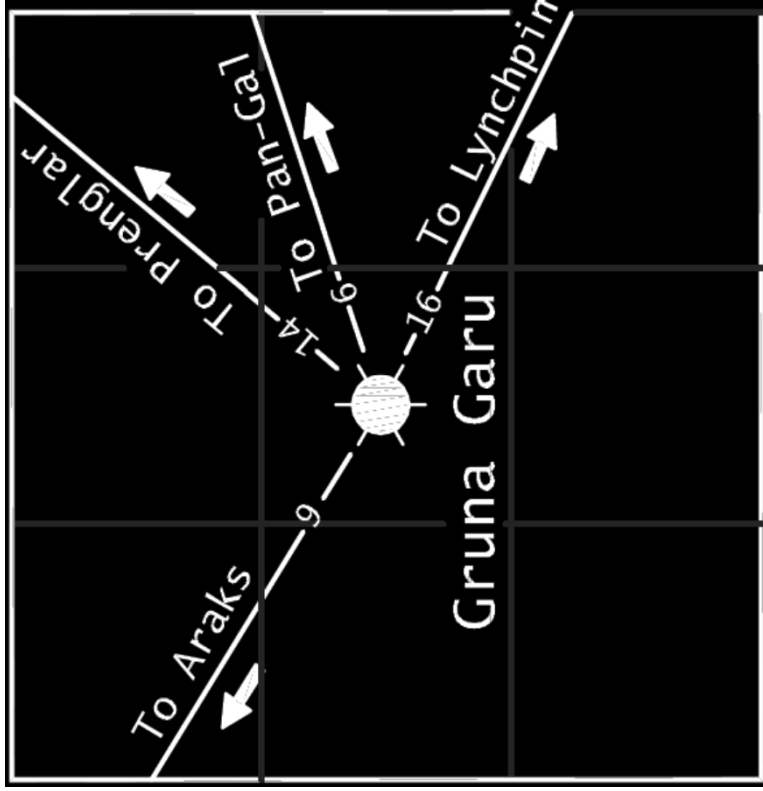

System Name	Planet Name	Moon Name	Notes	Source
Araks System				
	Araks I		Ringed with many moons. 18% volatile magma	AD
	Araks II		Many moons. 1 has trace atmosphere & polar caps	#2-p4
	Araks III (Hentz)		Theocratic terraformed home world of Yazirians	#2-p4
	Araks IV		Failed mining planet. Crashed starship, false Uranium readings	AD
Athor System				
	Athor I (Yast)			AD
	Athor Ia (Exib)		Economic center of the Athor system	#3-p5
	Athor Ib (Iime)			#3-p5
	Athor II			#3-p5
	Athor III		semi-solid ground	#3-p5
	Athor IV (Srah)			#3-p5
	Athor IVa (Jik)			#3-p5
	Athor IVb (Ezvoe)			#3-p5
	Athor IVc (Faan)			#3-p5
	Athor IVd (Spe)			#3-p5
Belnafaer System				
	Venturi		20 + small moons including Snobol	SFAD5
	Snobol		elongated orbit from 197,000 to 950,000 km from Venturi	SFAD5
	Wun Era			SFAD5
	Tor			SFAD5
	Gerand			SFAD5
	Zix			SFAD5
Cassidine				
	Rupert's Hole			AD
	Triad		1 moon. Major industrial planet. Most High tech is developed here.	AD
Dixon's Star				
	Laco		Laco Station in orbit. Polar caps are large seas	AD
Dramune System				
	Close Reach			AD
	Inner Reach			SFKH1
	Day High			AD
	Outer Reach		2 corporations control. One controls the surface, another the space lanes	SFKH1
	Diamond			AD
	Shadow			SFKH1
	Three Sisters A			SFKH1
	Three Sisters B			SFKH1
	Three Sisters C			SFKH1
	Lost Reach			SFKH1
Fromeltar				
	Groth			AD
	Terledrom		3 moons	AD

System Name	Planet Name	Moon Name	Notes	Source
FS#30				
	Snowball			SFKH4
	Akhala			SFKH4
	SFKH4			SFKH4
Gruna-Garu System				AD
	Gruna-Garu I (Hargut)	UPF Space Station "Stalwart" in orbit		AD
	Gruna-Garu Ia (Trefom)	Growing number of Yazirians looking for low G home. Has 2 small capacity space ports		#6-p28
K'aken-Kar				AD
	Ken'zah Kit			AD
Kizk'-Kar				AD
	Zik-kit			AD
Madderly's Star				AD
	Kdikit			AD
Ora System				#13-p48
				#13-p48
	Anthros			#13-p48
	Cyprust	Single giant lake of metallic hydrogen		#13-p48
	Ora Thei	11 moons. One is habitable		#13-p48
	Quintus			#13-p48
	Capernia	54 moons. Heavy with uranium deposits		#13-p48
	Ethlo-I	Forms a dual orbit with Ethlo-II		#13-p48
	Ethlo-II	forms a dual orbit with Ethlo-I		#13-p48
Prenglar System				AD
	Prenglar I (Aurora)	Strong magnetic field. Many mining colonies		#6-13
	Prenglar II	Of no interest or value		#6-13
	Prenglar III	5 large moons. Only 2 have any mineral value. All airless rocks		#6-13
	Prenglar Illa	some mining		#6-13
	Prenglar Illc	some mining		#6-13
	Prenglar IV (Morgaine's World)	VERY strict import/export regulations. 1 massive continent, 2 smaller island continents		AD
	Prenglar V (Gran Quivera)	Heavily industrialized planet. Electronics, engineering, & manufacturing goods. Hub of Frontier worlds.		AD
	Grey	Very rich in minerals. Extensive mining operations		#6-13
	Gold			#6-13
	White	Military Development base		#6-13
	Black			#6-13
	Prenglar VI	Icy chunk of stellar debris		#6-13
	Prenglar VII	Thick ammonia & methane atmosphere around a rocky surface		#6-13
	Prenglar VIII	Cold, dark and toxic. Has 2 icy moons of no interest or value		#6-13
	Prenglar IX	Some light mining and a military training outpost. 3 small moons		#6-13
Rhianna System				SFAD4
	Alcazzar	7 moons		SFAD4

System Name	Planet Name	Moon Name	Notes	Source
Scree Fron				AD
	Scree Fron I (Hyn)		Dumping ground for expended munitions and broken equipment	#4-p4
	Scree Fron II (Hakosoar)			AD
	Scree Fron III (Inti)		Home of the Merchant's School of Scree Fron. Spacer training	#4-p4
	Scree Fron IV (Inf)		Mining operation by LeMan Inc.	#4-p4
	Scree Fron V (Halol)			#4-p4
	Scree Fron VI (Histran)		Off limits to all but Spacefleet personnel	AD
	Scree Fron VII (a-g)		7 moons of no consequence or value	#4-p4
	Scree Fron VIII (Sfad3)			SFAD3
Sundown System				
	Sundown I (Sigis)		Extensive CDC mining operations	#16-p5
	Sundown II (a-u)		21 various captured asteroids as moons	#16-p5
	Sundown III (Rimini Belt)		contains numerous 1000+ km asteroids. Several mining operations and ore processing stations	#16-p5
	Starmist		Huge chasms that contain the atmosphere. Mountain tops are exposed to space.	SFAD3
	Sundown IV (Kirchgoens)		has 38 moons and 1 ring and an Ice core	#16-p5
	Sundown V (a-l)			#16-p5
	Sundown VI (Giessen)		has 50 moons, 2 rings and an iron/nickel core	#16-p5
	Sundown VII (Va-ax)			#16-p5
	Sundown VIII (Wetzlar)		covered in Methane Ice. A Klikk ship is buried beneath	#16-p5
	Sundown IX (Lahn Belt)		smaller asteroids. Has many independent mining operations	#16-p5
	Sundown X (Tubingen)		ongoing conflict between CDC and DelveCo. For control	#16-p5
	Sundown XI (Ayers)		ringed. Being mined by DelveCo.	#16-p5
	Sundown XII (b-c)			#16-p5
	Sundown XIII (Schloss)		Frozen ball. Rumored to have intact Klikk ruins	#16-p5
	Sundown XIV (Sturm)		home to House Zik'trin. Customs station in orbit	#16-p5
	Sundown XV (Thuringia)		Leased to CDC. Excellent source of precious metals. Has 3 moons	#16-p5
	Sundown XVI (Xa-c)		Leased to DelveCo for mining	#16-p5
	Sundown XVII (Butzbach)		solid inner core surrounded by liquid core. 38 moons and 3 rings	#16-p6
	Sundown XVIII (Xa-al)		Sector 6 secret listening post disguised as a deep space survey team	#16-p7
	Sundown XIX (p9)			#16-p9
Theseus				
	Theseus I (Icarus)			#16-p9
	Theseus II (Daedalus)			#16-p9
	Minotaur		3 continents, 1 was decimated by an asteroid impact long ago. The Athena Station is in orbit	AD
	Naxos Asteroid Field			#16-p9
	Theseus IV (Ariadne)			#16-p9
	Theseus V (Medea)			#16-p9
	Theseus VI (Hecale)			#16-p9
	Theseus VII (Pallas)			#16-p9
	Theseus VIII (Pasiphae)			#16-p9
	Theseus IX (Oedipus)			#16-p9
Timeon				
	Lossend			AD
				AD

System Name	Planet Name	Moon Name	Notes	Source
Tristkar System				
	Denzart			SFAD6
	Kraatar		10,000 km high mountain ranges	SFAD6
	Tivalla			SFAD6
	Setarz			SFAD6
	Tridar		many moons	SFAD6
Truane's Star				
	Pale		3 moons	AD
	NewPale			AD
Waller Nexus Federation				
	Mahg Mar			SFKH2
White Light System				
	Clarion (Gollywog)		90% of surface is rain	AD
Zebulon System				
	Volturnus			SFAD0
	Leo		Reddish orange	SFAD0
	Lulu		Bluish-silver	SFAD0

* moon days is time to orb

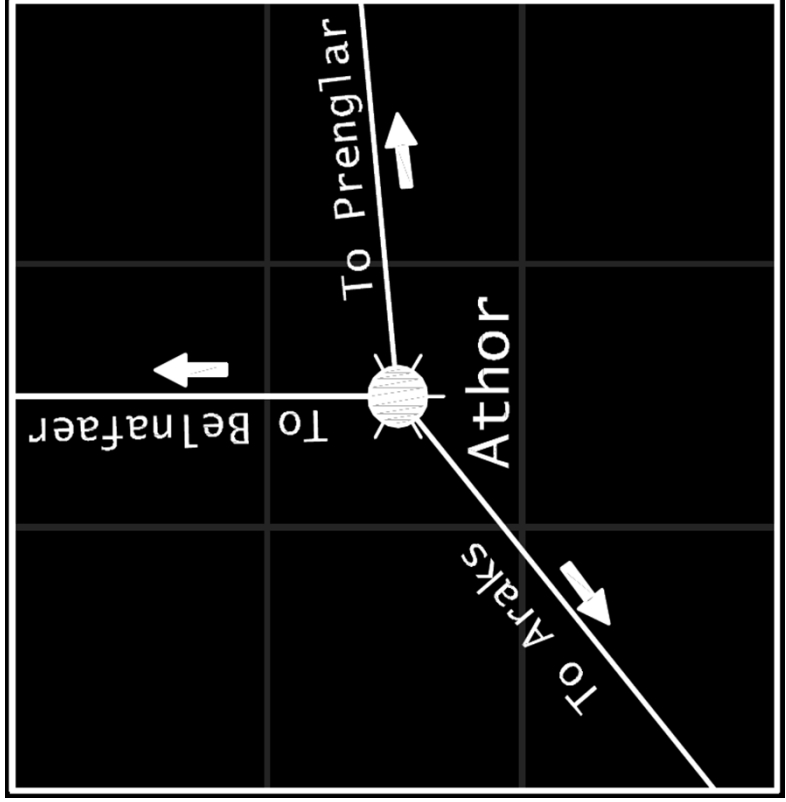

List of Alpha Dawn Alternate Skills and Sub-Skills

Animal Trainer		Source: #9-p1	Metabolic Control (Mentalist Source: AD Remastered p145)	
Analyze Animal Behavior	20% + skill level x10%		Enhanced Agility	40% + skill level x10%
Animal Training*	10% + skill level x10%		Enhanced Physique	50% + skill level x10%
Body Speak	100%		Enhanced Senses	60% + skill level x10%
Ride Mount	70% + skill level x10%		Heal Self	100% + skill level x10% - damage
Artisan (Intellectual)		Source: #9-p1	Hyper Movement	65% + skill level x10%
Appraise Art	10% + skill level x10% + notoriety adj.		Pheromone Emission	25% + skill level x10%
Create Art	30% + skill level x10% + situation adj.		5 Source: #9-p1	
Create Masterpiece	10% + skill level x10%		5 Ground Vehicles	40% + skill level x10%
Interpret Art	10% + skill level x10% + notoriety adj.		5 Hover Vehicles	30% + skill level x10%
Restore Art	40% + skill level x10%		Water Vehicles	30% + skill level x10%
Computer Skill (Technological)		Source: AD rules	Air Vehicles	20% + skill level x10%
Bypass Security	30% + skill level x 10% - prog level x 10%		System Vehicles	10% + skill level x10%
Defeat Security	60% + skill level x 10% -prog level x 10%		Space Vehicles	0% + skill level x10%
Display Information	80% + skill level x 10% -comp level x 10%		Dangerous Stunt	RS + skill level x10%
Interface Computers	30% + skill level x 10% -comp level x 10%		Psycho-Social Skill (Biosocial) Source: AD rules	
Manipulate Program	50% + skill level x 10% -prog level x 10%		Communication	40% + skill level x 10%
Operate Computer	100% + skill level x 10% - comp level x 10%		Empathy	10% + skill level x 10%
Repair Computer	40% + skill level x 10%		Hypnosis	15% + skill level x 10%
Write Programs	special		Persuasion	10% + skill level x 10%
Demolitions Skill (Military)		Source: AD rules	Psycho-Pathology	30% + skill level x 10%
Set Charge	30% + skill level x 10%		Psychokinesis (Mentalist) Source: AD Remastered p145	
Defuse Charge	50% + skill level x 10% -skill level x 10%		Fire Starter	40% + skill level x10%
Environmental Skill (Biosocial)		Source: AD rules	## Inertial Barrier	25% + skill level x10%
Analyze Ecosystems	30% + skill level x 10%		Levetation	50% + skill level x10%
Analyze Samples	50% + skill level x 10%		Sonic Barrier	25% + skill level x10%
Concealment	10% + skill level x 10%		13- Telekinesis	100% + skill level x10% - weight (kg)
Find Directions	50% + skill level x 10%		16-18	Source: AD rules
Make Tools/Weapons	100% if material available		16 Activate/Deactivate	100% robot level x 10%
Naming	100%		17 Add Equipment	100% -robot level x 10%
Steath	20% + skill level x 10%		18 Alter Functions	60% + skill level x 10% - robot level x 10%
Survival	40% + skill level x 10%		18 List Functions	90% + skill level x 10% - robot level x 10%
Tracking	30% + skill level x 10%		19- Remove Security Lock	70% + skill level x 10%
Linguist (Intellectual)		Source: #9-p1	21- Repair Robot	40% + skill level x 10%
Human Languages	50% + skill level x10%		27-38	Source: #9-p1
Dralasite Languages	50% + skill level x10%		27- Literature	1/2 LOG + skill level x10%
Yazirian Languages	50% + skill level x10%		31- History	1/2 LOG + skill level x10%
Vrusk Languages	50% + skill level x10%		34- Politics	1/2 INT + skill level x10%
Pan-Galactic	60% + skill level x10%		39- Economics	1/2 INT or LOG + skill level x10%
Language Comprehension	25% + skill level x10%		Pop Culture	1/2 INT + skill level x10%
Martial Arts (Military)		1/2 DEX or 1/2 STR + skill level x 10%	Law	1/2 LOG + skill level x10%
Medical Skill (Biosocial)		Source: AD rules	Philosophy/Theology	1/2 INT + skill level x10%
Activate Freeze Field	30% + skill level x 10%		Social Spy (Espionage) Source: #9-p1	
Administer Drugs	100%		Bluff	60%+ skill level x10% - target LOG
Control Infection	50% + skill level x 10%		Empathic Understanding	10% + skill level x 10%
Cure Disease	40% + skill level x 10%		Persuasion	60% + skill level x 10% - target INT
Diagnosis	60% + skill level x 10%		Society	30% + skill level x 10%
First Aid	100%		Spy Craft (Espionage) Source: #9-p1	
Major Surgery	20% + skill level x 10%		Cryptography	40% + skill level x 10%
Minor Surgery	40% + skill level x 10%		Forgery	40% + skill level x 10%
Neutralize Toxin	30% + skill level x 10%		Detect Forgery	60% + skill level x 10% - skill level x 10%
			Situational Awareness	special
			Surveillance	40% + skill level x 10% - 1/2 target INT
			Stealth	60% + skill level x 10%

List of Alpha Dawn Alternate Skills and Sub-Skills

Spy Gadget (Espionage)	Source: #9-p1
Computer: Access & Operate	80% + skill level x 10% - 10% x prog or comp
Detect & Deact. Defense/Locks	40% + skill level x 10% - security level x 10%
Operate Machinery	50% + skill level x 10%
Recognize/Use Spy Gadgets	40% + skill level x 10%
Identify Robots	100% + skill level x 10% - Robot level x 10%
Technician Skill (Technological)	Source: AD rules
Deactivate Alarms/Def.	40% + skill level x 10% - alarm level x 10%
Detect Alarms/Def.	60% + skill level x 10% - alarm level x 10%
Open Locks	50% + skill level x 10% - alarm level x 10%
Operate Machinery	50% + skill level x 10%
Repair Machinery	40% + skill level x 10%
Telepath (Mentalist)	Source: AD Remastered p145
Awareness	40% + skill level x10%
Clairaudience	20% + skill level x10%
Clairvoyance	20% + skill level x10%
Dominion	15% + skill level x10% - target LOG
Empathy	30% + skill level x10%
Read Thoughts	80% + skill level x10% - target LOG
Send Thoughts	70% + skill level x10%
Suggestion	40% + skill level x10% - target LOG
Telport Operator (Technological)	Source: #16-p93
System Operation	Success rate + skill level x10%
Target Acquisition	Success rate + skill level x10%
Troubleshoot	100%
Asses Security	60% + skill level x 10%
Repair Equipment	30% + skill level x10%
Signal Tracking	40% + skill level x10%
Signal Recall	20% + skill level x10%
Bypass Security	30% + skill level x10%
Network Interfacing	50% + skill level x10%
Disable Failsafe Protocol	20% + skill level x10%
TDM Coordinator	40% + skill level x10%
Modify Equipment	30% + skill level x10%
Weapon Skills (Military)	Source: AD rules
Beam Weapons	1/2 DEX + skill level x 10%
Gyrojet Weapons	1/2 DEX + skill level x 10%
Melee Weapons	1/2 DEX or 1/2 STR + skill level x 10%
Projectile Weapons	1/2 DEX + skill level x 10%
Thrown Weapons	1/2 DEX + skill level x 10%
Others (Individual sub-skills. Not selected as a group)	
Thievery	1/2 DEX + skill level x10%
Deductive Reasoning	1/2 INT or LOG + skill level x10%
Athletics	1/2 STR or STA + skill level x10%