

ISSUE

12

July  
2009

# STAR FRONTIERSMAN Magazine



*Frontiersmen, Unite!*

# STAR FRONTIERSMAN Magazine

## FRONTIER FEEDBACK

Alpha Dawn Remastered Errata  
by Dale C. Blessing..... 1

## TIME BOMB

Story based on a role playing session with the  
Galaxy Rangers by Richard Ryley ..... 6

## SATHAR BRIEFING REPORT

By Tom Verreault/jedion357 ..... 35

## THE MOTIVATION OF THE SATHAR

By Chris Putnam ..... 36

## THE VERSATILE ION DRIVE

By Gary Cliff (BD Cerridwen) ..... 38

## THE INDUSTRIOUS IFSHNIT

By Kimber "Kim" Eastland, Revised by C. J. Williams  
..... 42

## PLANETARY BRIEF

Laco in Dixon's Star  
By Shadow Shack ..... 45

## GROUND & HOVER CYCLE HISTORY

By Shadow Shack ..... 47

## NEW EQUIPMENT

Yazirian Triple Barrel Gyrojet  
By Chris Harper ..... 48

## THE CORE FOUR-PART I

A Look at Dralasites and Humans  
By Brian Conway ..... 48

## CHARACTERS-R-US

By Larry Moore ..... 54

## INSPIRATION ZONE

Sathar Adventure  
By Sam Quier ..... 57

## THE KEEP IT ROLLING STORY

SF Community story in RGP format ..... 58

## CHARACTERS WITH CLASS

A Class and Level System for Star Frontiers  
By Bill Logan ..... 62

## STAR FRONTIERSMAN

A comprehensive table of contents, issues 1-12  
By C. J. Williams ..... 72

**On the cover:** The name of this image is "Tarriance," by artist Gary Tonge. Used with permission. Check out his other great works at his website and let him know what you think about his skills:  
<http://www.visionafar.com/>

### Artwork Credits

Special thanks to Gary, Shell and Dirk for the last-minute art contributions. Art makes the issue come alive.

- (1) <http://themrock.deviantart.com/>
  - (2) <http://staino.deviantart.com>
  - (3) <http://atomicknight.deviantart.com/>
  - (4) <http://s2.photobucket.com/albums/y35/Storn/>  
Tom Verreault/jedion357 (Battle Rage vs Coke)
- Shell  
C. J. Williams  
Larry Moore  
Ben Norman  
Scott Mulder  
Chris Harper  
Richard "Shadow Shack" Rose  
Parriah (Jess Carver)

# FRONTIER FEEDBACK

Dale C. Blessing

## EDITOR'S NOTE

The Frontier Feedback section is a new addition to the Star Frontiersman magazine. This is the "letters to the editor" section where you can send in questions, comments or suggestions about articles seen in previous issues of the magazine the magazine itself or any of the Remastered! projects. All submissions for Frontier Feedback should be sent to [submissions@starfrontiersman.com](mailto:submissions@starfrontiersman.com) and should ideally include "Frontier Feedback" in the subject line.

If you have specific questions or comments about the articles from previous issues, we'll try to get the authors to respond and post your questions or comments along with their response.

## ALPHA DAWN REMASTERED ERRATA

Following is a lengthy section submitted by Dale C. Blessing. A great deal of hard work went into these errata, and for that you have our thanks. **NOTE:** The page references are page numbers in the book and not the PDF page number.

**Page 18. DAMAGE.** First and second paragraphs should be combined into one paragraph.

**Page 18. AVOIDANCE ROLLS.** (Last sentence) If the result is equal to or less than the indicated ability score, the character has avoided or resisted the attack.

**Page 23. EXPLANATION OF RESULTS.** SPEED -20/TURN.

(Last two sentences should be separate paragraphs.)  
SPEED -20/TURN. The vehicle must reduce its speed at least 20 meters/turn until it is stopped. It can decelerate more than this if the driver wants, but it can not accelerate.

**SPIN.** See Control Table results.

**Page 30. ABILITY SCORES.** Last paragraph. He's happy with the current distribution and opts not to personalize the scores by shifting any points among their pairs.

**Page 35. HUMAN CHARACTERS.** Movement Table. Running 30 meters per turn

**Pages 49 and 50. MAJOR SURGERY.** Last two sentences of descriptive paragraph.

Major and minor surgeries are effective only on wounds. They can not be used to heal damage from infections, diseases or poisons.

(These two sentences should be a separate paragraph.)

**Page 53. Beam Weapons.** Sonic Disruptor. Range. 2/10/20/40/-  
(Delete last /-)

**Page 53. Archaic Weapons.** Bow.  
Rate = 1/2

**Page 53. Archaic Weapons.** Musket.  
Rate = 1/3

### Archaic Weapons Table

Bow Rate should be "1/2" and not "1".  
Musket Rate should be "1/3" and not "1".

**Page 53. Melee Weapons.** Missing weapon.

Weapon	Melee	Wgt	Damage	Def
Mug	+0	1	1d5	Inertia
Chair	-15	1	1d10	Inertia
Club	-5	1	1d10	Inertia
Pistol Butt	-10	--	1d10	Inertia
Rifle Butt	-5	--	2d10	Inertia
Spray Hypo	-20	--	Special	STA

**Page 54. Toolkit or Refill.** Wgt (kg). Incorrect weight listings.

Item	Wgt (kg)
Techkit	20 kg
Robcomkit	15 kg
Envirokit	5 kg

**Page 56. Laser Pistol.** (Last sentence, rule is incorrectly stated)  
An albedo suit or screen protects against the damage from lasers.

**Page 58. Tangler Grenade.** Missing copy.  
A character that passes a Reaction Speed check has avoided entanglement.  
(Add above sentence to the descriptive paragraph.)

**Page 60. POWER SCREENS.** First sentence.  
All powerscreens except the holo screen are worn like belts around the waist. Special adapters are provided for Dralasites at no extra cost. Only one powerscreen can be worn or used at one time. Putting

on or taking off a powerscreen takes five turns. When a screen runs out of power it has no effect.

**Page 61. Robocomkit.** Sixth item in list missing bullet point.

- Demagnetizer--electrical tool to demagnetize fouled circuits
  - Spray cleaner--spray solvent to remove dirt from the robot's works; 10 applications
- (These two items should have separate list entries.)

**Page 70. GRAVITY.** Second sentence.

This is simply the strength of gravity on the planet. It is measured in multiples of 1 g, which is considered normal gravity. The effects of gravity are described in the section on Movement.

**Page 70. NOTES.** Last sentence. Missing word.

Some planets have additional notes following the table. These describe unusual cultures or planetary features. The referee can make up any other information he needs about the planets when he designs adventures to take place on them.

**Page 72. THE FRONTIER WORLDS.** System/ Planet column has incorrect spelling.  
Gruna Garu

**Page 84. AIR WHALE.** Table.  
Move Slow - 30 meters/turn

**Page 84. AIR WHALE.** Second descriptive paragraph. Third sentence and sixth sentence.

Crystal-based life forms have a symbiotic relationship with the air whale. These crystals focus sunlight into a beam, much like a laser. The crystals can fire up to six shots per turn, with damage divided as desired among the attacks. The damage allotted to each shot must be decided before the combat result is rolled. The crystals also store solar energy, and can fire two shots when direct sunlight is not available. An albedo screen or albedo suit will reduce damage suffered as usual. From the bottom of the creature hang hundreds of razor-sharp tentacles 10 meters long. The air whale can make 10 attacks per turn with tentacles. Tentacle attacks must be rolled separately. Note that the air whale has two different attack forms depending on whether the victim is above or below the creature.

**Page 84. BABOON, VOLTURNIAN.** Table.  
Move Medium - 60 meters/turn

**Page 84. CYBODRAGON.** Table.  
Move Fast - 90 meters/turn

**Page 85. FUNNEL WORM.** Table.  
Move Slow - 30 meters/turn

**Page 85. GIANT EAGLE.** Table.  
Move Slow on land - 30 meters/turn, Fast in air - 90 meters/turn

**Page 86. KORRVARR.** Table.  
Move Slow - 30 meters/turn

**Page 86. LAND WHALE.** Header name.  
LAND WHALE

**Page 86. LAND WHALE.** Table.  
Move Medium - 60 meters/turn

**Page 87. MORDAX.** Table.  
Move Medium - 60 meters/turn

**Page 87. ROLLER.** Corrected Table. Replace the table on page 87 with this table.

Type Large Herbivore

Number 5-50

Move Fast - 90 meters/turn

IM/RS +4/38

Stamina 300

Attack 80

Damage 8d10 roller

Attack 60

Damage 1d10 shard grass missiles

Range 5/10/15/20/30

Special Attack None

Special Defense Hide cannot be penetrated by Needlers. Projectile weapons cause half damage.

Native World Volturnus - shard grass plains

**Pages 87 and 88. ROLLER.** First descriptive paragraph. Second sentence and fifth sentence.

DESCRIPTION: A roller is a large herbivore named for its unusual "steam roller" type organ. This organ is actually a huge, cylindrical, hide-covered mass of bone and cartilage attached to two frontal limbs by ball and socket joints. The organ is used to crush the shard grass on which the creature feeds. The mouth of the roller is located on its underside. The crushed shards and shoots of shard grass are sucked up into this mouth. Internal organs of the creature separate the glass-like shards from the digestible shoots of grass. The indigestible shards are then stored in a special organ and used as missile weapons for the creature's rear defense. The roller has four normal limbs used for locomotion. The two eyes of the creature are located on the head near the large ears. The head does not have a mouth. A roller has a thick hide that protects it from being cut by shard grass.

(Remove "from the digestible" from original sentence and make corrections in red.)

**Page 88. SAND SHARK.** Table.  
Move Medium - 60 meters/turn

**Page 88. SAND SHARK.** Last descriptive paragraph. The sand shark can cross rocky areas by slithering across the surface, but its movement rate is reduced to Slow - 30 meters/turn.

**Page 88. SLAVEBOT.** Table.  
Move Medium - 60 meters/turn

**Page 90. WINGED RIPPERS.** Table.  
Move Fast - 90 meters/turn

**Page 90. WINGED RIPPERS.** Last descriptive paragraph. Last sentence.

Rumors exist of a larger classification of these creatures that nest only in the highest peaks of Volturnus. These Large beasts are equally cowardly, but can be raised as mounts if captured while young. These giant winged rippers are the source of cave drawings and tall tales, passed on through generations. If these fabled beasts do exist, their statistics would vary as follows: IM/RS +5/45, Stamina 60, Attack 65, Damage 2d10 beak, movement is unchanged while carrying a man-sized load, but is slightly faster when unencumbered.

**Page 91. YERNOIDS.** Table.  
Move Slow - 30 meters/turn

**Page 91. YERNOIDS.** Table.  
Special Attack 30% likely to be armed with clubs (1d10 (-5) )

**Page 91. ZWERRAH.** Table.  
Move Medium - 60 meters/turn

**Pages 93 and 94. NPC FRIENDS AND FOES.** Second paragraph. Last sentence. Missing copy.

By the same token, referees should be prepared to keep track of the people, corporations, and political groups that the player characters cross. That way, when they encounter the same people again (or characters, corporations, or political groups affiliated with those people), they will have the same reaction to the characters.  
(Replace "period" with "comma" and add missing copy.)

**Page 95 and 96. SAMPLE NPC'S.**

NPC	Change
YAZIRIAN SCOUT	PS = +2
DRALASITE ENFORCER	IM = +4
DRALASITE FIELD TECH	IM = +5
VRUSK EXPLORER	IM = +4
VRUSK SEER	IM = +4

**Page 108. ALPHA 6.1: SIGHT AND MOVEMENT.**  
Table.  
Hills 2.4 Move per Hour (km)

**Page 110. COMBAT AND MOVEMENT.** Third Paragraph. Last sentence.  
The map key distinguishes between hard and soft cover objects.  
(This section of the map graphic is missing.)

**Hard Cover**  
Engines  
Computer  
Instrument Panel  
Cargo Cabinets  
Security Door  
Pressure Door  
Regular Door

#### Soft Cover

Large Table  
Small Table  
Chair  
Hatch  
Bed

**Page 112. GAMMA 4.1: CARGO SEARCH TABLE.**  
Missing Wgt.  
81-85 Yazirian punching bags 2kg

**Page 115. Burrower Snake.** Missing copy.  
(MV Slow; IM 8; RS 80, STA 15; ATT 75; DM 1d5; SA Poison S5/T10)

**Page 119. EPSILON 3.1: RANDOM ENCOUNTER TABLE.**  
7 Skeleton and drained laser pistol

**Page 120. 6) FLITTERS.** Missing copy.  
(MV Medium; IM 7; RS 70; STA 10; ATT 40; DM 2; SA Disease)

**Page 122. 5) BURROWER SNAKE LAIR.** Missing copy.  
(MV Slow; IM 8; RS 80; STA 15; ATT 75; DM 1d5; SA Poison S5/T10)

**Page 124. 12) THE MAGMA MONSTERS.** Missing copy.  
(MV Very slow; IM 3; RS 30; STA 150; ATT 30; DM 3d10; SA/SD See below)

**Page 131. MAGMA MONSTER.** Table. Special defense.  
Special Defense Immune to needler, projectile, stun, tangler gren, doze gren, 1/2 damage from laser, frag gren.

**Page 131. MAGMA MONSTER.** Last Paragraph.  
Due to the magma monster's hard outer shell, it is not affected by tangier grenades, needler, or projectile weapons. Doze grenades and stun weapons of any sort will not affect it either, since the magma monster's life force is based on thermal energy and these weapons are designed to achieve their effects through bio-chemical manipulation. Magma monsters take only 1/2 damage from lasers and fragmentation grenades.

**Page 131. MUTATING FUNGUS.** Last Paragraph.  
Any character who is exposed to the mutating fungus for eight hours or more, or who sleeps near it for any amount of time, will find a white, pasty growth covering parts of his body. If the character notices the presence of the fungus within three hours of its attack, he may treat the infected part of his body with antibody plus and counteract the effects of the fungus (though he will not be protected from further attacks!). If the character is not treated within three hours, the infected body part must be amputated, or the character will be completely consumed by the fungus within three

days. Any character exposed to a mutating fungus for three days without treatment will be transformed into a mutating fungus permanently. (Add ") after "attacks!".)

**Page 132. RASTIES.** Table.  
IM/RS +7/65

**Page 134. PLAYER CHARACTER BACKGROUND REPORT.** Various.

Itklikdil  
Cartographer  
Vrusk Atlas Manufacturing Corporation  
PS +2

Geeko-sur-Mang  
Professor of geology, Capital University  
PS +2

Grod  
Technician  
Truane's Star Civil Service  
PS +3  
Skills: 5th level all skills in Technological PSA

**Page 135. PLANETARY BRIEF.** Heading. Missing copy.

Star Frontiers System Brief  
Voturnus (Zebulon star system) (Star Color: Yellow)

**Page 138. Map of Voturnus.**

(It is impossible to read the information in the map legend.)

Fix: Obtain an original SF-0: Crash on Voturnus module. The map is printed, in color, on the inside of the heavy card cover. The legend is readable. This module was included in the original Star Frontiers and Star Frontiers Alpha Dawn box sets.

**Page 139. Forbidden Caverns Map.** Key.  
S = START

**Page 141. VARIABLE SKILL LEVELS.** Descriptive paragraph. Last sentence.

..., at least one additional skill must be chosen from outside of your character's Primary Skill Area.

**Page 144. PARTIAL POLYPLATE ARMOR.**

Protection. Second sentence.  
It absorbs half damage from all laser and physical attacks.

**Page 144. FULL POLYPLATE ARMOR.** Protection. First sentence.

..., if that damage comes from a laser weapon or physical/inertial source.

**Page 145. Mental Endurance.** First paragraph. Third and fourth sentences.

As they use their powers, their Mental Endurance points deplete. When they are out of Mental Endurance points, they cannot use their mental powers until they recover.

(Remove "s" in "depletes".)

**Page 145. Mental Endurance.** Second paragraph.

The amount of Mental Endurance points it costs to invoke a Mentalist skill is equal to a number of d10 based on the invoked skill level. Thus if you used Enhance Physique (from the Metabolic Control skill) at level1, you will use 1d10 Mental Endurance points. If you had 4 levels of that skill and invoked only 3 of them, you'd use 3d10 Mental Endurance points.

(Replace "take" and "sustain" with "use". Replace "damage" with "points".)

**Page 145. Mental Endurance Recovery.** First sentence.

Mentalist recover their lost Mental Endurance points at a rate of 1d10 points per hour spent sleeping or meditating.

**Page 145. ENHANCE AGILITY.** Descriptive paragraph. Last sentence.

At a cost of 1 additional Mental Endurance point per turn, he can continue to keep the power invoked until he turns it off or runs out of psychic energy.

**Page 145 and 146. ENHANCE PHYSIQUE.** Descriptive paragraph. Last sentence.

At a cost of 1 additional Mental Endurance point per turn, he can continue to keep the power invoked until he turns it off or runs out of psychic energy.

**Page 146. ENHANCE SENSES.** Descriptive paragraph. Last sentence.

At a cost of 1 additional Mental Endurance point per turn, he can continue to keep the power invoked until he turns it off or runs out of psychic energy.

**Page 146. HYPERMOVEMENT.** Descriptive paragraph.

The Mentalist concentrates for a full round then invokes this power. If successful, his movement rate will increase by a multiple equal to his skill level. For example, a Vrusk Mentalist (base running movement rate 35 meters per turn) that invoked a level 3 Metabolic Control skill could increase his running speed to (35 x 3 =) 105 meters per turn! This power can be kept up by spending further Mental Endurance point, but the character can't keep this level of activity up for any longer than he could normally run (a number of minutes equal to his Stamina score). Note that this same multiple applies to all leaping and jumping distances. At a cost of 1 additional Mental Endurance point per turn, he can continue to keep the power invoked until he turns it off or runs out of psychic energy.

**Page 146. INERTIA BARRIER.** Descriptive paragraph.

The character concentrates one round then invokes this ability. If successful, he has the equivalent of an Inertia Screen up. Each turn it is on drains one Mental Endurance point (in addition to the invocation cost, of course). It protects the character from half of all ballistic damage. Each time it is struck, regardless of the amount of damage it absorbs, the character sustains another point of Mental Endurance damage.

**Page 147. LEVITATION.** Example paragraph.

For example: A character has a Psychokinesis skill at level 3. He successfully invokes this power and can now ascend at 3 meters/turn, descend at 6 meters per turn, or travel about horizontally at a rate of 6 meters per turn. It costs him 3d10 Mental Endurance points to invoke this. Before the hour is over, he invokes a second time, costing another 3d10 Mental Endurance points and doubling his movement rate. Each hour thereafter, he can continue his double-speed movement rate by spending one more Mental Endurance point per hour.

**Page 147. SONIC BARRIER.** Descriptive paragraph.

The character concentrates one round then invokes this ability. If successful, he has the equivalent of a Sonic Screen up. Each turn it is on drains one Mental Endurance point (in addition to the invocation cost, of course). It protects the character from half of all Sonic damage. Each time it is struck, regardless of the amount of damage it absorbs, the character sustains another point of Mental Endurance damage.

**Page 147. AWARENESS.** Second descriptive paragraph.

This skill also allows a character to read psychic impressions left on an object by the last person who used it. Information that can be gained includes what the user looked like, what he thought while using it, what he was doing for the last few hours before the item was lost, stolen, or otherwise left his possession. The longer the item has been untouched, the dimmer the impression. This skill is used most often by Star Law officers and spies.

**Page 147. CLAIRAUDIENCE.** Descriptive paragraph. Last sentence.

Successful invocation lasts one minute per level, and then may be continued as long as desired by spending one more Mental Endurance point to invoke it automatically again.

**Page 148. CLAIRVOYANCE.** Descriptive paragraph.

A character with this skill can "see" a distance of 10 meters per skill level (if the area is known to him) or 5 meters per skill level (if the area is unknown). This directional sight focuses on an area that is no larger than a 5-meter radius. It is affected as sight would be by darkness or light attacks (flash grenades). Successful invocation lasts one minute per level, and then may be continued as long as desired by spending one more Mental Endurance point to invoke it automatically again.

**Page 148. SUGGESTION.** Descriptive paragraph.

You invoke this power, make your skill roll, spend your Mental Endurance points, then state a simple suggestion you'd like the intended target to follow. The suggestion can't be obviously suicidal, and can't instruct the person to do something that would cause him obvious harm. If successful, the target will do what you suggested.

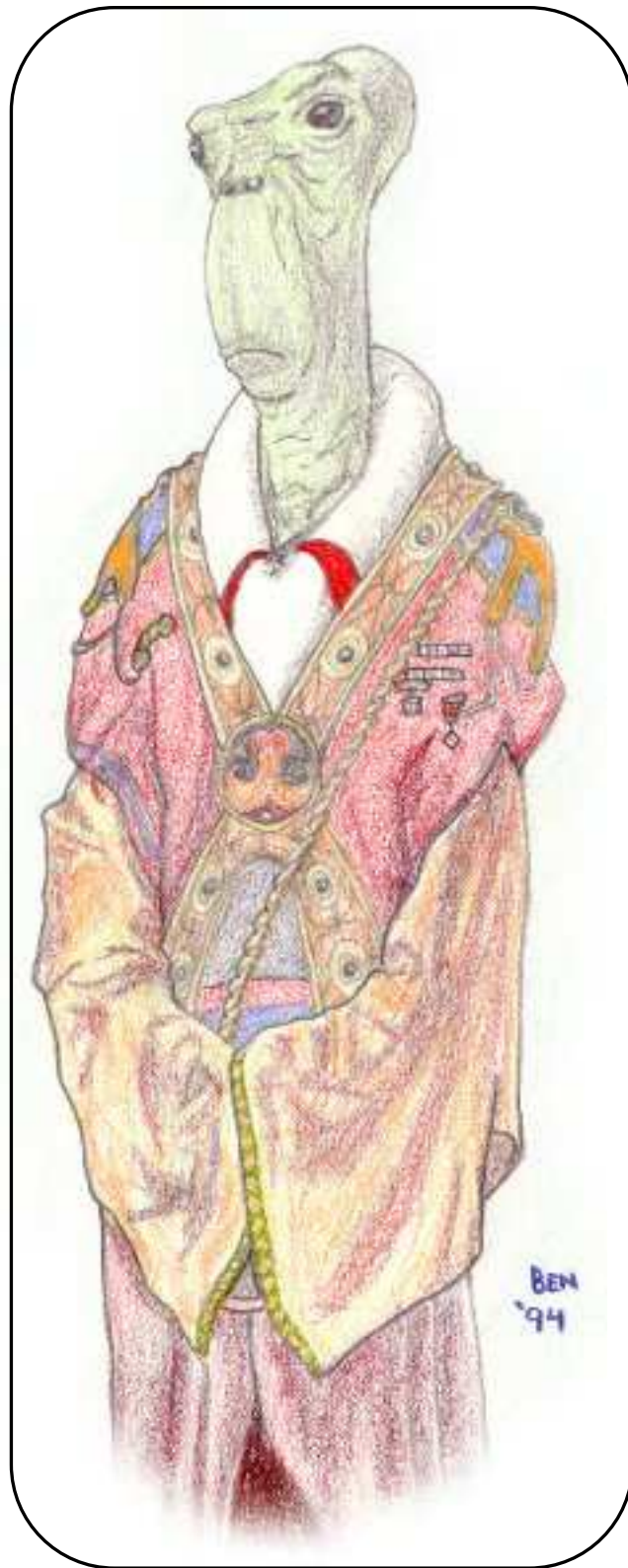

# TIME

# BOMB

**Richard Ryley**

**EDITOR'S NOTE:** Some of you might remember an 80's cartoon called "The Adventures of the Galaxy Rangers". Richard Ryley started a play by email campaign several years ago based on a freeform RPG system. After the adventure he compiled a short story. This is that story.

**Larry Moore** "What RPG system did you use?"

**Richard Ryley** "I used a very freeform system for the RPG, which was played by email. It was loosely based on a system I found somewhere, I can't remember the exact details, but in essence the idea was you gave the player a choice of two options in discussion, and which option he took determined if he succeeded or failed. You chained a bunch of these choices together to create any mix of odds from 50% to 25% to whatever. What I ended up doing is coming up with rules off the top of my head to base a check off of the players' post, for instance "is the third word of the second sentence more or less than 4 letters?". That way I didn't have to ask them, I just had them role play what they were doing and I told them if it worked.

It was a bit vague, but it was really flexible and led to some great scenes. For instance, when Goose used Killbane's device to try and recharge his badge, I told him he wouldn't know if it worked until he tried it. When he tried it, in the final fight, I made a roll, and the charge failed. However, he just kept acting like it hadn't, and I made another roll, and the bluff worked. So that whole bit was generated randomly. :D"

Character	Player
<b>Gamemaster</b>	Richard Ryley
<b>Shane Gooseman</b>	David Wills
<b>Walter "Doc" Hartford</b>	Luther Frisch
<b>Zozo</b>	James Grabowski/Stephen Long
<b>Buzzwang</b>	Robert Richards
<b>Daisy O'Mega</b>	Anastasia Atomaczyk

## Chapter 1

Out on the edges of League Space, a thick asteroid belt circled a Black Hole. It seemed to be an inhospitable place, a region that could in no way support life, but its appearance was deceptive. Deep inside the asteroid field, there was one chunk of rock much larger than all the rest. It glittered with light, glowing from within in many colors, which shone through portals in the solid stone.

The inhabitants of this section of space called it Entropy's Edge. And the outlaws and cutthroats who hid out on this asteroid, so far from the law and order of Earth and her allies, called themselves the Black Hole

Gang. The Bureau of Extra Terrestrial Affairs, and their Galaxy Rangers, called them by that name as well.

Daisy O'Mega preferred to call them scum. She'd been the leader of the gang for several years, until Shane Gooseman of the Galaxy Rangers tricked her, and Macross took over leadership of the gang. To be honest, it was probably all for the best. In the year since, she'd done a hell of a lot better for herself than when she'd been saddled with that pathetic band of miscreants. But the insult of it all still grated on her.

What made it worse is that she suspected that she let herself be tricked. Shane was a handsome devil, and she had the feeling that he would have been more of a reward than any robbery would have netted. But he was a Galaxy Ranger, and although she'd asked him to go with her, before she made her escape, she would have no holds on her. She'd lived that life before, and she'd hated it.

Even so, the Black Hole gang had almost been the biggest mistake of her life. She was running from the duty of being a full-time bounty hunter. So why on Earth did she take ON the responsibility of running a GANG? No, in the end, she bore no enmity to Shane for getting her out of that mess.

But Macross was another matter.

Daisy looked up as her boy came into the bar. He spotted her, back there in the shadows, even though she wasn't wearing her trademark shawl, and her hat was down over her eyes. It wouldn't do for her to be recognized, right here in the enemy's camp. She knew the rock better than even Macross did, though, and she knew how to get around Entropy's Edge without being seen.

"What have ye got for me?" she muttered, as her spy took a seat.

"Well, earlier this week, Macross got a visit from this fellow named Killbane. Ryker Kilbane, I think his name was."

Daisy nodded. She'd done a little research into Shane's background. This Kilbane was a Supertrooper, like Goose. Had very much the same powers, too.

"Anyway, he said he wanted to hire Macross. Had a lot o' credits, too. A LOT o' credits. He said he needed a backup man for a plan to take out the Galaxy Rangers."  
"What kind of a plan?"



"Well, that I don't know, exactly. They went into the meetin' hall, and I couldn't eavesdrop after that. If they'd caught me, they'd have strung me up for sure..."

\*Coward\* Daisy thought to herself. "Don't worry about it," she said out loud. "What makes you so sure he was after the Rangers?"

"Well, before they went inside, he said... and this is exactly what he said... I think... 'I've found out something that will spell the end of the Galaxy Rangers. They can't fight it, they can't run from it, they can't hide from it. You and me, Macross, we'll hold the lives of the Galaxy Rangers in our hands... especially that wimp Gooseman...'"

Inwardly, Daisy smiled. Gooseman, a wimp? Hardly. Looks like he might be owing her a favor soon. That could prove interesting. Besides, there was no way in HELL she would let something with this kind of power wind up in the hands of Macross.

"All right, let's say I'm intrigued. Where is Kilbane now?"  
 "He left. He said he would take care of his part of the bargain, and Macross would stay and take care of his. Ever since then, he's had us building these weird devices... transmitters of some kind. All of Entropy's Edge is working on them."

"Hmmm... And you don't know where Kilbane is?"

"Actually, yes I do. He told Macross to meet him on Prairie. The boss is also putting together a team to do some other kind of job. They've been doing some vigorous training. I'm told some of it looks like they're being trained to go up against the Rangers."

"Okay. Thanks. I'll look into it." The redhead dropped some coins on the table, as she left the bar, pulling her hat down a little as she vanished into the shadows.

\* \* \* \* \*

"Galaxy Rangers... please, come in..."

Commander Walsh gestured at the three Rangers standing in the door of his office. Zozo was already there, yawning, and Gooseman, Doc and Buzzwang filed in to stand beside him. The commander looked up at the door, as if expecting someone, then sat down at his desk.

"I just received a call from Senator Wheiner. I tried to convince him that this is not Ranger business, but I'm afraid he wouldn't listen. I'm sorry to ask you all in here like this, but at least Zack and Niko are away on other business. If I had my way..."

The burly man's speech was cut short by a commotion from out in the hall. There was the sound of running footsteps, and the protests of one of Walsh's aides. "Sir! You can't go in there! The Commander is in a meeting!"  
 An imperious voice answered him. "Of COURSE he is! I

CALLED that meeting! Now, out of my way!"

"But sir!..."

The door, already open partway, flew open as a figure strode into the room. He was a greasy-looking man, with dark graying hair and beady eyes. He wore the familiar brown uniform of a Senator, with his badge of office, a green caplet, over his shoulder. Senator Wheiner had arrived.

"Look here, Senator..." Walsh began, but Wheiner ignored him.

"Galaxy Rangers... I regret having to come to you, of all people, to deal with this situation, but I see no other choice. My daughter MUST be returned to Earth IMMEDIATELY, and the utmost secrecy is needed..."

"Now, see here!" Walsh began, but Goose interrupted. "Don't tell me your daughter's gone to Tortuna to shoot another Rock Video..."

"I hope not," interjected Buzzwang. "I barely got her out alive the LAST time..."

"That's not..." cut in Walsh.

"I remember that incident all too well," answered the Senator. He frowned accusingly at the Rangers. "I have tried and tried to make Eve understand that you grandstanding troublemakers are NOT worthy of her respect, and yet she always seems to find SOME way of emulating you and your grandiose methods. She even had the NERVE to talk BACK to me!!!!"

"You can't blame us for that..." Zozo began, but was interrupted, as Walsh brought his walking stick forcefully down on the table. All eyes turned to him as Zozo put both hands up to his pointed ears.

"Now that I have your attention..."

The Senator snorted. "Grandstanding son of a..."

"When I spoke to the Senator," Walsh said loudly, cutting him off, "he said that his daughter had taken something, and gone back to Prarie, where she is currently going to school. You wouldn't tell me what it was over the comm, Senator, so what's going on?"

"Eve broke into my private office safe, and STOLE a top secret computer disk! You've GOT to get her back here right away! She's probably gotten involved with some hooligans at that school, and..."

Walsh looked startled. "Top secret information! WHAT information?"

In a fraction of a second, the Senator went from concerned parent to a sudden and inexplicable anger. "YOU GET THIS STRAIGHT, COMMANDER! THE INFORMATION ON THAT DISK IS TOP SECRET! NEITHER YOU NOR ANY OF YOUR RANGERS IS TO LOOK AT IT! IS THAT CLEAR?????"

The commander threw up his hands. "Perfectly, Senator. But how valuable is this information? Should we expect trouble? Does anyone else know about this?"

Wheiner shook his head. "No. The information has been hidden away in my safe for the past two years. No one has seen it but my Committee."

Walsh paused for a moment. "We'll get your daughter back, Senator Wheiner. And the disk as well."

"All right. Just remember, that information is TOP SECRET." He stared at Goose, Doc and Zozo again. "If ANY of you looks at ANYTHING on that disk, I will have you all up on Contempt charges... if not TREASON!"

"Settle DOWN, Senator. The Galaxy Rangers are under my command, and if I order them not to look at the disk, they won't. And the treaty we have with the Kirwin government allows me to get an assurance from Zozo, as well."

Zozo blinked. He'd been grinning widely, and suddenly looked as if he'd been caught with his hand in the cookie jar.

Walsh looked at the Rangers. "So... Galaxy Rangers, I order you not to look at that disk... and Zozo, I want your word as an Ambassador that you will not look at it either..."

Zozo sighed. "Very well, Commander. But keep in mind..." He shot the Senator a dirty look. "Kirwin will not be all that happy if this turns out to be a wild goose chase."

"WILD GOOSE CHASE!!!" Wheiner pulled himself up, barely containing his rage. Walsh was quick to cut in. "If it does, Ambassador, your government will have my utmost apology... as well as my thanks for retrieving the daughter of one of our... public servants."

Wheiner managed to hold his look of fury for a few more moments. Then, he sighed. "Very well. Bring my daughter back..." Looking a bit deflated, he left the room. Walsh put a hand to his forehead. "He's gonna owe me big time for this one... my Galaxy Rangers... BABY SITTING..."

"Commander..." Buzzwang began. "If we cannot look at the disk, how will we know if we have the right one? We will not be able to look at the label if we cannot look at the disk..."

Walsh looked confused for a moment, then irritated. "No, Buzzwang, I don't mean that you can't look at the CASE of the disk. I mean that you are not to access the DATA on the disk..." He glanced at Doc. "And that means no sending Pathfinder in to read it, either..."

Doc feigned a look of shock. "I wouldn't THINK of such a thing..."

Walsh held his gaze for a moment, and Doc put up his hands. "Okay, okay! Hackers just don't get any respect..."

Walsh shook his head. "Look fellows... I gave my word. And going around the letter of it is just as bad as breaking it. Consider that information officially off limits..."

He paused for a moment, and then glanced at the door. "Quite frankly... I don't think there's anything of any importance on that disk. Two years ago, we hadn't even met the Andorians yet. The biggest thing going on was the failure of the Supertrooper project, and I KNOW where all that data is. So I think this is just our Senator believing that he's more important than he is."

"If it seems like someone really wants that information, and your lives are in danger unless you know what it is, then consider yourselves as having a 'need to know'. But otherwise, humor the man..."

Walsh leaned in a little closer. "And if anyone asks me, I'll tell them that I never told you that... so it BETTER be a matter of life and death."

## Chapter 2

The trip to Prairie was uneventful, and the Rangers and their Kiwi ally were soon walking along the paved walks and manicured lawns of the campus of the College of Prairie. Several students could be seen on the grounds, walking between classes, or sitting out in the grass studying.

The native sentient species of the planet, wolf-like creatures called Lycans, could also be seen around the campus. Many of them walked alongside the students as they went from class to class, or sat outside of a classroom, waiting. While Lycans were intelligent creatures, far more intelligent than a domesticated dog, their innate loyalty and devotion to the humans that befriended them, made them excellent guardians.

The doors swung open on a nearby building, and a crowd of students stepped out into the sunlight, heading off in all directions. One of them, a young girl in a green outfit, with her hair up in spikes, stopped to pet the Lycan waiting for her on the steps. It gave her a bark of welcome, and then she and some of her friends turned to head off across the campus. Then, suddenly, she spotted the Galaxy Rangers.

"GOOSE!" The girl yelled, a girlish tone to her voice. She ran across the lawn towards Gooseman, while her friend, who had the same spiky hair, but in blue, pulled aside another girl. The third girl also seemed to

recognize the Ranger, as her friend pointed him out, and they joined the first girl in running across the lawn. "It's so good to see you again!" The girl said, her eyes sparkling as she looked up at the blonde Ranger. Gooseman glanced at Doc, clearly confused, and more than a little embarrassed. The second girl quickly took his other arm, and Shane looked down at her, completely flustered.

"Who... What..." he stuttered.  
 "What are you doing back so soon?" "Where's Eve?"  
 "You look hungry... you wanna get something to eat?"  
 "Who's your cute friend?"

The third girl had latched onto Doc's arm. "Don't look at me, my Gooseman..." Doc commented. "You're the one with the reputation..."

He glanced down at the girl. "Aren't you a little young for a guy like me?" He asked with a grin.

The girl giggled. "You're so funny..." She cooed, and held the Ranger's arm tighter. Doc sighed.

The Lycan, approaching the group, seemed no less excited to see Goose. But as he neared, he suddenly stopped dead. His ears went back as he lowered his head, growling. In a single, rapid bound, he shoved himself between Gooseman and the girl in green, shoving her away from him.

"Max! Stop that!" The girl in green admonished the wolf. She started to reach out to Gooseman, but the Lycan shoved her back again, eyeing the blonde Ranger suspiciously. "Max! This is Goose! Remember Goose? What is WRONG with you!"

Shane began to back away, holding both hands up in front of him. "It's all right, Max. I won't hurt your friend."

"That's right," Buzzwang added. He took a step forward. "Perhaps I will be less threatening, Ranger Gooseman," he said, then extended a hand to the Lycan.

The wolf stared at the android. Its eyes narrowed, and it began to back away from him, its ears back on its head. Buzzwang wisely withdrew his hand, but Zozo stepped forward. "Lycans always like me," he said, and knelt in front of the animal, extending both arms. "See! We're friends!"

Max barked at him, loudly, causing the little Kiwi to jump back. The wolf then ran around behind the girl. It grabbed her by the arm, trying to drag her away, and she cried out. "MAX! STOP! You're hurting me!"

The Lycan let go immediately. He ran back around in front of the girl, putting himself between her and the Galaxy Rangers. He looked at Goose, Zozo, and Buzzwang, finally staring at the android's badge for a long moment. Max began barking at Buzzwang, warningly. He kept looking back at his friend, as if

frustrated that she could not understand what he was saying. The way he was barking at Buzz, it was almost as if he was telling him, as firmly as possible, to do something.

Doc smiled. It suddenly occurred to him that the dog sounded just like Walsh did when he was barking orders. He decided not to voice that unflattering comparison, though. "These Lycan's are a lot smarter than most people realize," he said. "He clearly knows something, but he just can't tell us what it is."

"Max..." The girl was really starting to get flustered. "You're embarrassing me."

The wolf gave her an apologetic look. It glanced back at Gooseman, and then up at the young girl. It then barked, slowly and carefully, still trying to make itself understood.

"Try gestures, Max..." Buzzwang said. "We know that you sense that something is wrong. We just don't understand what it is..."

The Lycan stared at him for a moment. He looked at the android's chest, obviously at his badge. He then looked at Goose, and then at his badge. Quite pointedly, it sniffed the air. It shook its head, then looked at the android again.

Buzzwang looked at Gooseman, then back at the wolf. "I believe I have it, Ranger Gooseman. When we arrived, these girls greeted us. But you do not know them, do you?"

Goose looked decidedly uncomfortable. "Well... no..."  
 "WHAT!" The girl said, clearly angry. "HOW CAN YOU..."

Buzzwang put up his hand. "Young lady, how long ago did you last see Ranger Gooseman?"  
 "Not three days ago," she snapped, "So you can forget whatever kinda..."

"Please, miss..." Buzzwang interrupted. "For the past week, Ranger Gooseman, Ranger Hartford and myself have been on Earth, several light years from here. There is no way you could have met with him within that time."

The girl's mouth fell open. "But..." she looked up at Goose, and the look of confusion on his face finally registered with her. She put a hand to her mouth. "You really don't know me, do you?"

The Lycan, meanwhile, was looking the Goose over, as well. Buzzwang glanced down at the wolf, then back at his fellow Ranger. "Max was able to sense that you were not the Ranger Gooseman he met before," Buzzwang continued. "He must have concluded that you were an impostor. But since you have been with us all this time, I consider it more likely that the Ranger Gooseman that the girls met is the impostor. Since his appearance coincided with the disappearance of Eve

Wheiner, we must conclude that he took on your form to kidnap her."

"EVE!" The girl's eyes got huge, as she stared at the android, holding both hands up to her mouth. "Oh, my God..."

"Well, that explains that," Doc said. "Don't worry, miss. We're here to get Eve back. I assume you know her..."

She nodded. "I'm Eve's roommate... My name's Deborah. And this is Annie and Julie." She indicated the two girls. "And Max you already know..."

The dog sat down in front of Gooseman. He looked up at him, uttering a short "wuf", clearly satisfied. Goose scowled at the dog, then turned to Buzzwang.

"Check with the spaceport, see if there have been any mysterious takeoffs or landings within the last three days. And see if Eve Wheiner is listed as a passenger on any ship leaving this sector."

"Right away!" Buzzwang's communicator unfolded from his wrist, and he began to chatter with a spaceport official on the other side of the line.

Shane looked back at Debbie. "How long ago did Eve leave with this impostor?"

"Right after he arrived," she answered. "He said something about her father wanting her to come home. Which I thought was fishy... I mean, he SENT her out here, didn't he?"

"It was obviously a trap for her," Doc said. "Eve was supposed to have stolen an important disk from her father's safe. The disk was stolen yesterday."

"There must be some mistake!" Debbie protested. "Eve would NEVER steal anything!" Her friends both nodded, agreeing.

"I have the information you wanted, Ranger Gooseman," Buzzwang cut in. "There is a flight plan registered for an Eve Wheiner from Prairie to Earth, three days ago. No passengers were reported, only Eve herself. According to the records, she returned to Prairie two hours ago, landing at Runway Alpha."

"If this guy could impersonate you," the girl named Julie said, "maybe he could impersonate Eve, too..."

"Is the ship still there?"

"Yes." Buzzwang paused. "But it's not registered to Eve OR her father. The ship is registered to YOU... Shane Gooseman."

Debbie whistled. "This guy has a lot of gall."

Shane nodded. "This impostor... he looked just like me?"

"Yeah..." The young girl wrapped her arms around

herself. "Eve recognized him... well, you... right away. And he even... well, he even had Series 5 implant powers." She looked up at Goose. "Your powers."

"There's only one person in the Galaxy who has the same powers as you, my Gooseman," Doc said.

Shane's eyes narrowed to mere slits as he growled the name. "Ryker Kilbane..."

### Chapter 3

"I guess this means we won't be back in time for lunch..." Doc quipped.

"What's Ryker Kilbane doin' hanging around with the Black Hole Gang?" Gooseman growled in response.

The Galaxy Rangers were ducked down behind a stack of barrels, staring across at the hangar, and the Ranger Interceptor tucked away inside it. From this distance, it was clear that it was not really a BETA spacecraft, but simply modified, and painted to look like one. At a distance, however, or as seen by Earth's sensor net, it would probably seem to be the real thing.

Two of the Black Hole Gang's thugs were sitting around it, one of them the large fellow in the red mask, the other the little dog-like guy. Both were carrying laser rifles. Goose checked the clips on his blasters.

"We've caught 'em by surprise!" Zozo said excitedly. "Shall I take the little one?"

"I'd like to get to that ship and see what the 'Doctor' can find out," Doc added.

"That's fine with me," Goose said. "Leaves more for the rest of us."

"I've got a better idea." Buzzwang says. "I can get onboard the ship as well as Doc, and that would leave him free to fight."

Before either of them could move, however, the door in the alley behind them suddenly swung open, and a tall, lanky alien with green hair stepped out. "GALAXY RANGERS!" He yelled, drawing his blaster.

"Whoawhoawhoawhoawhoa!" Zozo called out, dancing around as the blaster fire stuck the concrete in front of his feet. Goose pulled out his own blasters, driving the alien back towards the door, but the Black Hole Gang had been alerted. Laser fire began to lance out at them from the hangar.

"We are caught in a crossfire, my Gooseman," said Doc.

"Yeah... NOW it's startin' to get interestin'..."

There was a blaze of light from Gooseman's badge, the familiar melodic hum of his implant powering up, and Goose's body began to glow with light. Not a moment too soon, either, as the alien outlaw drew a bead on him and opened fire. Goose ran right through the barrage of laser fire, his glow intensifying, as he

charged at his foe.

As the glow died down, Gooseman's body had transformed into crystal. The laser beams bounced off of him, uselessly, as he reached the alien and grabbed his gun, throwing it aside. The two then locked hands, a crystal man and a green haired alien, each struggling to throw the other down.

Zozo, meanwhile, charged in the other direction, as the dog man was coming at them from the cover of the hangar. Doc laid down a pattern of cover fire as Zozo ran out into the street to face their attacker.

The dog-man swung his rifle, but Zozo leaped over the arc. As the little Kiwi came back down, he grabbed the rifle, wrenching it out of the dog man's grasp. It landed on the pavement, and Zozo leaped over to grab it.

"Ha! NOW I got you!" Zozo glanced down at the rifle. "How does this thing work..."

The rifle went off, spraying the dog-man with laser fire. He began to dance around as Zozo had, grunting, "Yah yah yah yah yah!"

"Help!" Zozo yelled, trying to find the control to turn off the automatic fire. The dog-man was running around in circles, now. "How do I STOP this thing!" He threw the rifle down on the ground, and began jumping up and down on it, breaking it into pieces.

"You broke my rifle!" The dog-man yelled, charging at him. "Yaaaaahhhhh!"

Zozo took off running back towards the alley, but as he reached the wall, he suddenly kicked off of it, leaping upward and back over his opponent's head. At the same moment, Buzzwang shoved a handtruck into the alien's path. The dog-man tripped over the dolly, and slammed headfirst into the wall, knocking himself out. Zozo slapped his hands together, dusting them off. "No problem."

Doc cried out as the man in the red mask opened fire again, and the laser blast cut into his shoulder. He dropped back behind the barrel, pulling out his own pistol, as Zozo and Buzz joined him. "No problem," Doc echoed, wincing as he put a hand to his shoulder.

"This situation does not look good," Buzzwang commented. "The third gang member was using his radio a few moments ago. We must assume that reinforcements are on the way."

Two hovercraft roared around the corner up the street. One slid to a stop in front of them, while the other stopped closer to the hangar, blocking their path to the Interceptor. The alleyway became filled with laser blasts.

"Thanks, Buzzwang," Doc snapped.

He glanced back at Goose, still struggling with the green haired alien. "My Gooseman, we are in SERIOUS trouble here..."

He was interrupted as another hovercar roared into view. It accelerated, heading straight for one of the cars, and struck it forcefully, shoving it into the wall of another hangar. The Black Hole Gang members struggled to regain control of the careening vehicle, several of them flying out and landing prone in the street.

Daisy O'Mega stood up in the seat of her hovercar. "Get in!" She stared at the dumbstruck Rangers for a moment. "Come on, boys! Don't just stand there with yer jaws flappin' in the wind!"

"The cavalry has arrived!" Doc yelled, leaping out into the street and into the back seat of the hovercraft. Buzzwang quickly joined him, but Zozo glanced back at Gooseman, still pummeling the green haired alien.

"Can we trust her?" He asked.

"No..." Daisy answered, her Irish brogue getting thicker in her exasperation, "An' I don't trust you Rangers, either. But I'd rather pull yer arses outta this mess than leave ya to Macross. NOW GET IN!!!!!"

"I believe we should accept Miss O'Mega's offer," Buzzwang said, in his mechanical voice. "I believe the Black Hole Gang have recovered from their initial shock."

Daisy dropped down in her seat as the gang opened fire, filling the street with a blaze of colored light. Doc whipped around in his seat, returning fire with his own blaster, and Daisy quickly followed suit. "Get in, boys," she warned, "or I'm leavin' ya here..."

Zozo quickly jumped into the back seat, Goose taking only a few more moments to slug his opponent across the chin. He then ran out of the alley, his body flashing with light as returned to his normal form. "GO!" He yelled, as he scrambled into the passenger seat, next to Daisy.

"Hang on!" Daisy countered. She gunned the engine, and the hovercar made a full one eighty degree spin, almost throwing Zozo out into the street. She slammed into the gang's hovercar again as she passed it, sending it spinning out of control, as she shot back the way she came.

Patch, Macross's second, yelled for his men to sit down, as he gunned the engine of his hovercraft. Before he could move, however, another hovercraft, piloted by the man in the mask, shot out of the hangar in front of him. Patch followed, and the last hovercraft brought up the rear, several of the gang members still trying to climb into it as it passed.

Daisy looked back at their pursuers. A hail of laser fire began to shoot past them, and she floored it. "I knew I shouldn't have come back for you guys..."

"Pardon me, Miss O'Mega," Buzzwang began, "but where exactly are we going?"

"Well, I thought I'd take the Scenic route through Prairie, then we'd go out to dinner, then Shane and I will go and dance the New Texas two-step at the club..."

"WHAT DO YOU THINK I'M DOING HERE...! I'm tryin' ta ditch these low grade morons so we can get back to the Starport and go after Macross!!!"

"It's good to see you on our side, for once," Goose told her, as he turned back in his seat, leveling his blasters at the car behind them.

"I'm on nobody's side but me own, Shane Gooseman," she said, then cut him a sly glance. "Although I could be persuaded..." She returned her attention to the road, cutting around a corner and into the traffic of Prairie's city streets.

#### Chapter 4

"Don't nobody say nuthin' about women drivers," Daisy commented, as she swerved around the traffic, even as the other cars scurried to get out of their way.

"Well, at least she's not as bad as you, my Gooseman," Doc quipped. "After being a passenger in something you're driving, I suppose I can survive anything..." He added his own fire to Goose's, and Patch's windshield cracked. The white haired fellow dropped back, the other two hovercraft moving up to take his place.

A stray laser blast grazed Daisy's door, however, and the car was knocked sideways. The melted chunk of composite bounced off the roadway and into a nearby shop, shattering the storefront window. As the traffic coming in the other direction swerved to avoid the debris, the cars ahead of them were forced to stop, blocking the lane ahead.

Daisy made a hard right turn, throwing her passengers around in their seats, as she whipped around into a side alley. The car careened off the brick wall, then roared off down the alleyway, their pursuers still right behind.

"I take it back!" Doc exclaimed. "You ARE as bad as Goose!"

They shot out of the alley under an awning, and Goose took out its supports with a couple of well placed shots. The fabric fluttered down over the car that was right behind them, blinding the driver. Daisy made a right turn into the traffic, nearly flipping the car up onto its side. The Black Hole Gang's car, on the other hand, sailed straight on across the street, slamming into the wall of a building, and exploding in a ball of flame.

"Good shot," Daisy commented.

"Good driving," Goose answered.

Daisy grinned at him. "Thanks."

"DON'T WATCH ME! WATCH THE ROAD!"

Daisy's attention snapped back to the street as an enormous hover tanker headed right at them. "Hang on," was all she said.

The hovercar was still coming down from its sideways turn into the street, and she jerked the wheel hard to the left, causing the car to flip up onto its other side. They shot through the gap between the tanker and the wall with only inches to spare. The car behind them, trying the same maneuver, got pinned by the tanker and was crushed against the wall.



Artwork by Themrock (1)

The final car, the one with the cracked windshield, skidded to a stop at the end of the alley. The huge tanker continued past them, its horn blasting. By the time the way was clear for them to continue, Daisy and her new allies were gone. Patch stood up, looking around, but the Galaxy Rangers had made their escape.

"Am I the only one who's afraid for his life, here?" Doc asked, as Daisy cut another wild corner, putting as much distance as she could between herself and the

Black Hole Gang. "Where's Zozo?"

A small, furry blue hand stuck itself out from under the car seat. "Under here."

Doc paused a moment. "If there was more room, I'd say move over..."

"All right, Rangers, listen up!" Daisy glanced back over her shoulder, beginning to slow down as she assured herself that she wasn't being followed. "I've got some inf'mation fer ye, but I'll be askin' fer a pardon in exchange fer it..."

Gooseman looked a bit pained as he considered his options. From the back seat, Doc grinned. "I think she's got us right where she wants us..."

Goose sighed. "Okay... I'll see that you get that pardon." He raised a hand to cut her short. "On the condition that we get the girl and the disk back."

"Ah... ye know about that, then... I figgered that was why ye was here..."

She looked at Goose. "That rat Macross met with yer friend Ryker Kilbane earlier this week. They've got some kinda plan, and they're turnin' the Black Hole Gang upside down 'cause o' it. They'll be takin' the girl AN' the disk back ta Entropy's edge, just as soon as they can get off this rock."

"We figured that much," Doc said. "What makes you think that info is worth a pardon?"

Daisy glanced back at him. "Ye din' know what's on the disk, then?"

Doc's grin faded. "No, we don't. It didn't sound like it was anything important..."

"Nuthin' important... that ain't how I heard it. Ryker seems ta think that whatever's on that disk will slip the end of ya... of all of the Galaxy Rangers!"

Doc and Goose looked at each other. "I guess you'd call that a 'need to know,'" Doc muttered. "Even so... our first priority is to get the girl back."

"Now, how did I knew ye were ginna say tha'?" Daisy turned a corner. "Well, if we're lucky, Macross hasn't taken off yet. Ye can rescue the girl 'afore she even gets off Prairie..."

Unfortunately, by the time they pulled up to Macross's hangar, it was long empty. "Dang," Daisy muttered. "They give us the slip." She dropped back down in her seat, and the hovercar rocketed off in another direction.

She stopped in front of another hangar, and hopped out. The Rangers joined her as she slid open the doors, to reveal a small spaceship, an attractive orange-gold in color. It was a bit large for an Interceptor, but much

smaller than Ranger Two.

"This outta get us ta Entropy's Edge. I've got a lad in the gang that can help us out. From there on out, it's up to ye Rangers... and a bit o' luck..."

"And where did you get this?" Goose asked.

"I won it fair and square, Galaxy Ranger." Daisy countered. She typed a code into the access panel, and the canopy opened. The ramp extended down to them, and Doc, curious as usual, made his way inside.

"She's a pretty little thing, an' got a few surprises o' her own. Not as nice as me own battlecruiser..." She grinned at Gooseman. "But she'll do."

"All the same... I think we'll take Ranger Two."

"Ye'll never get past the Black Hole Gang's sensors in that thing," Daisy countered, laughing. "The whole rock'll know you're there before you come within a hundred light years..."

Daisy put a hand on her ship's landing strut. "This baby is the only thing that's gonna get you onta Entropy's Edge in one piece," she said.

Doc poked his head out of the canopy. "No kidding! Daisy, are you aware that you've got a Blue Fire generator up here???"

"Is that wha' it's called?" Daisy says, looking up at him. "It wasn't even workin' when I got it. The idiot who had it before me apparently didn't even know what it was."

Doc stared at her for a moment. "You mean, you're the one that wired it this way?"

"Yeah, what of it?"

"Daisy... a Blue Fire generator is designed to disable tractor beams. But the way you've got it wired... well, Daisy, you've figured out how to make it jam SENSORS, as well!"

"I thought tha' was what it was supposed ta do..."

"My Gooseman," Doc said with a grin. "I think the odds just turned in our favor."

## Chapter 5

The Rangers piled into Daisy's interceptor and headed for Entropy's Edge. It was a tight fit, but the ship wasn't built for luxury, and Zozo was small enough that he was able to get relatively comfortable between the two rear seats.

Doc, of course, took the computer console. He pulled out his CDU and triggered his badge. There was a musical sound as the power of his implant flowed through him, and the I/O port of the CDU opened. The bright, flashing diamond shape of Doc's power flickered

into view.

A tiny, yellow ball of fire zipped out of the gate. "Firefly," Doc commanded. "Get in there and see if you can get the Tractor Dispersion Field working, as well as the Sensor Scrambler. We might need it on this mission."

"Righty-O, Doc!" The little tweaker flew into the computer panel, and lights began to flash on it. Within moments, a nimbus of blue flame encircled the ship.

Daisy checked her readouts. "Well done, Ranger," she said.

She pulled back on the thrust lever, and the interceptor's engines fired. It shot forward, as a brilliant ball of blue-white light formed ahead of them. It spread out into a star-shape as the ship shot into Hyperspace, and then a ring of brilliance spread away from where the ship had been.

Thousands of light years away, in an asteroid belt orbiting a black hole, the ring of light appeared again. Daisy's interceptor shot into view, coasting to a stop as the inertia of Hyperspace wore off. Behind it, the star shape dwindled back into the ball of light, and then vanished. This time, however, the light was reddish.

"Welcome to Entropy's Edge, boys," Daisy said, as the interceptor coasted towards the largest of the asteroids.

Doc shot Daisy a sidelong glance, smiling. "Now \*that's\* what I call a welcome! No bad guys welcoming us themselves with their blasters pointed at us. Yet."

Daisy parked on a nearby asteroid, close enough to be inside the Black Hole Gang's sensor field, but far enough away that it wouldn't be spotted visually. The gang then changed into their familiar red and white space suits, except for Buzzwang, of course, who just put on a jetpack. Daisy slipped into the golden suit that came with her interceptor.

They rocketed over to the station and landed near one of the maintenance ports. "I've got this 'un, Ranger," Daisy told Doc. She typed a code into the access panel, and the port opened.

The Rangers slipped through the airlock. Daisy triggered the control, and the portal dilated shut. "All right, boys, we're inside," Daisy said, taking off her helmet. "Where to no'?"

"Where would the girl be held?" Goose asked.

"In the prisons, most likely. I know a way." She stepped up to another panel next to the wall, and opened an access way into a small tunnel. "This is a maintenance shaft. We should be able to sneak past the internal sensors through here."

The maintenance shaft led to a narrow power conduit and from there to a series of ventilation shafts. Daisy

led them through the maze of passages. She seemed confident in her sense of direction, and also knew when they were getting near inhabited areas. She motioned the Rangers to silence as they approached one area, where there was some obvious activity going on.

The Rangers paused above a large work area, looking out from behind a vent high up on the wall. Machinery was moving around in the room, members of the gang working frantically. They were producing electronic devices of some kind, turning them out by the dozens.

"My spy told me about they'd been put to work on something mysterious," Daisy said quietly. "I wonder wha' it is they're all workin' on?"

"Must be related to that missing disk... well, maybe..." Doc shrugged. "Goose, you want 'dibs' on the girl? Maybe I can get my tweakers to uncover something important about those devices."

"All right," Gooseman agreed, "but watch out for alarms..."

"Watch out for alarms," Doc echoed, as if taken aback. "My Gooseman, you're talking to the Doctor, remember?"

"Just be careful," Goose cut in warningly. "I'll leave Buzzwang with you. The two of you see if you can figure out what they're up to. If worse comes to worse, we may have to blow this rock to stop them."

Doc raised an eyebrow. "Glad you're on my side..."

Goose looked at Daisy. "You and Zozo are with me. If we're gonna get the girl back, we'll probably have to fight our way through."

"I'd rather give Macross a piece o' my mind..." Daisy commented. "An' find out about that disk..."

"You and me both," Doc muttered.

"We don't know where Macross is, OR the disk, so let's concentrate on what we DO know."

"Right," Doc agreed. "You guys go on. If we can locate Macross or the disk, we'll try and stall him until you guys can catch up with us. Right now, getting Eve back is our first priority."

Goose continued crawling down the narrow passage, with Daisy and the little Kiwi right behind him. Doc watched them for a moment, then setted in front of the grille that overlooked the big room below. He stared at the gang members moving around in the room for a second or two, then pulled out his CDU.

A familiar hum filled the air as Doc triggered his badge. With a series of musical tones, the glowing portal to Cyberspace opened, a jumble of colored lines and numbers flashing within it. "Pathfinder! Get in there and find out what they're building. And be careful you aren't seen!"



"They'll never know I'm here, Doc!" The little blue sphere said in its high pitched voice, as it zipped out of the gateway. It dropped through the grille, and down out of sight, behind some boxes.

The tiny mote of light darted across the room, from box to table and back again, working its way across the room. A gang worker turned to examine something, and Pathfinder swooped around behind him, slipping into his machine. It popped out the other side, and then passed through a few more machines, as it made its way to a bank of computers.

After a few moments in the computers, Pathfinder shot back out, and disappeared into the wall. A few seconds later, it appeared from the aluminum of the air duct, and returned to Doc.

"I'm not sure what they're working on, Doc," Pathfinder said. "They're building some kind of transmitters. From the looks of it, they're old-style radio transmitters, with a range of maybe a few miles. They're programmed to echo any signal that they receive."

"There's hundreds of them..." Doc said, looking down through the grate at the objects coming off the assembly line below. "Enough to blanket an area of several thousand miles with a radio signal..."

"Doc..." Buzzwang said. He seemed to be attempting to make his comments sound offhand. "Would it be possible for Pathfinder to retrieve some information, and then give it to me, instead of you? I could, for instance, analyze the information, and then erase it from my memory... if need be..."

The hacker looked at his android companion, a wry grin on his face. "Still thinkin' about Walsh's order not to look at the disk, eh?"

"Well..."

"Look, Buzz, my momma didn't raise this Ranger to be no fool. If Macross an' Kilbane BOTH think there's something on that disk that could kill me, well, orders or no orders, I'm gonna look at it." He grinned.

"I see..."

Doc's expression turns serious. "What is it, Buzz? You think you know what's on that disk?"

The android paused a moment. "I'm... not sure. If I could just get a look at one of the devices. If it is a transmitter, perhaps it would be a good idea if I tried to find out what the frequency it transmits is, so that we might be able to build a jamming device..."

Pathfinder glimmered in the darkness of the vent shaft, as he darted back and forth for a few moments. "I'm sorry, Ranger Buzzwang," it said, "but there was no indication of what the signal was to be, or what frequency it would be on. Those are amplifiers,

designed to echo the signal, not broadcast it."

"That makes sense," Doc said. "Kilbane didn't even have the disk until a few days ago. These guys had to have been working on these devices for weeks. So, they couldn't have known what the signal was supposed to be when they designed them."

"But!" Pathfinder interrupted. "There is something else. The devices have also been programmed with a secondary system, to detect the hyperspace signature of a Ranger spacecraft. When the signature is detected, another signal is sent, on standard subspace frequencies. Maybe we could jam THAT!"

Doc nodded. "We need more information. Buzzwang, let's see if we can find an empty room and get OUT of this ventilator. If I stay in here one more minute, I'm gonna turn into a pretzel!"

## Chapter 6

Goose, Daisy and Zozo looked out of the ventilator duct into the prison area. From their vantage point high in the wall, they could see a single guard, asleep in a chair in the guard room. It was the dog man again, napping right next to the controls for the prison cells. Gooseman left his two companions behind for a moment to check the other air ducts.

"He's sound asleep," Daisy said as Goose returned, gesturing at the guard in his chair below them. "In all th' time ye been gone, he ain't moved a bit. Shall we catch th' little fleabag by suprise?"

"He may still hear us and wake up," Goose countered.

"There's an open cell up ahead that you can get into through the vent shaft. You two slip in that way, and I'll wait here by this vent. If you wake him up, he'll be distracted, and I can drop in on him from behind. If you don't wake him, you can take him out, and then let ME in."

"Good enoo'," Daisy said with a smile. "All right... it's you an' me, then, furry face." She gestured for Zozo to follow, and crawled further down the shaft.

A few minutes later, Goose heard the quiet sound of boots hitting metal. Daisy was being careful, but the guard still sat up. As Goose had suspected, he hadn't been asleep at all. Grabbing his rifle, the gang member cautiously approached the hallway leading to the cells.

Gooseman waited just long enough for the guard to get around the corner, then kicked in the grate. It hit the floor with a clang, and the dog man came running back into the room. Goose met him with his fist, knocking the little alien reeling. He stepped backward, trying to get away, but Daisy came up behind him, and knocked the thug out with the butt end of her blaster.

Goose quickly checked the door. "Looks like we got in without alerting the others," he said. "See if you can find the girl."

"Right," Zozo said, and turned back into the hallway. Less than a second passed before he called out, quietly, "She's in cell 15. You'll have to switch off the force field from out there, Ranger Gooseman."

"Okay... I got it." Goose flipped a switch on the control panel the guard had been sitting next to. There was the sound of a force field powering down, and then Zozo ran back into the room, with a young girl, with black spiky hair, right behind him. Eve immediately ran to Goose, hugging him tightly.

"Oh, Shane... Ranger Gooseman... thank God it's really you! I was so scared..."

"It's all right now," Goose said, awkwardly trying to soothe the girl's nerves.

"We have to get you back to Earth," Zozo said. "Your father is worried about you."

"But we'll have to get through the Black Hole Gang to do it," Goose said. He pushed Eve away, looking at her sternly. "You're going to have to do exactly as I say, and stick close to us. This isn't some Rock Video, this is the real thing..."

Eve nodded. She was trembling, and had a bruise on her forehead, as if Macross's men had roughed her up. Other than that, fortunately, she seemed to be all right. "I know, Ranger Gooseman. I'll stay out of trouble. And I'll stay out of trouble from now on."

Goose frowned, sure that THAT promise will be soon forgotten. At least she seemed to be too frightened to strike out on her own. "Okay. We're going back out the way we came in... through the ventilation system. I'll take the lead, and Eve, I want you to stay right behind me, and be as quiet as you can. Okay?"

As Gooseman picked up the fallen vent from the floor, however, the door to the corridor outside slid open. Daisy picked off two of the gang members immediately, her blasters in her hands so fast Goose didn't even see her draw them. But more Black Hole Gang men came up behind them, and multicolored laser fire began to fill the small room.

There was nowhere to go but back into the cellblock. Goose held the steel vent cover up like a shield, as he rushed the door. "Get Eve out of here!" he yelled at Daisy. "I'll hold them off!"

Before Daisy or Eve could move, however, the laser fire suddenly cut off. Goose was thrown backwards as the gang members forced their way through the door, their sheer numbers too much to hold back. A deep, gravelly voice cut through the sudden silence.

"Oh, no you won't, Ranger boy... Not unless you want to see your robot friend here on my desk as a paperweight..." Macross stepped into the room, holding Buzzwang firmly, with an arm around his neck. The android struggled, but his hands were cuffed, and Macross was holding a gun to his head.

Macross grinned evilly at Gooseman, his beady red eyes glittering in triumph. His men, coming up behind him, leveled their laser rifles at Goose, Zozo, Daisy -- and Eve. "Drop your weapons, Ranger boy... or not one of your friends will be leavin' this room alive."

Goose glared at the outlaw leader for a long moment. "Ok, Macross," he finally said, dropping his blaster. "but whatever scheme you've got going here, you'll not get away with it."

"Oh, but I HAVE gotten away with it... or to be precise, your buddy Killbane's gotten away with it. The disk, I mean. And your friend Hartford, too. He's got a NASTY surprise in store for him..." Macross chuckled, a low guttural sound.

"You should consider yourself LUCKY that Kilbane an' I decided to deal with you ourselves. Now you be a good little Ranger, and file back into the cell block..."

Goose scowled as he stepped back into the corridor between the cells. Macross kept his blaster trained on Buzz's head, nodding to Zozo and Daisy, as well. "Move it, you two. Follow the Ranger boy."

The Ranger and his two allies reluctantly backed into the cell. Macross nodded to his men as soon as they were safely inside, and then shoved Buzzwang forcefully into Gooseman. As the Supertrooper tried to duck around the android, and head for Macross, an arc of energy danced across the front of the cell. Gooseman slammed into the force field, and was thrown back.

Macross chuckled again, as the energy field again settled to its normal, transparent form. Then he smirked at Daisy. "Too bad you chose the wrong side. Did you think I didn't know about your 'boy on the inside'?" He laughed. "Too bad. We could have been something."

Daisy said nothing, just looked away from him, crossing her arms. "I'll be back for you, Ranger boy, just as soon as I check in with Kilbane." Macross left the cell room, leaving a couple of guards behind to watch his prisoners.

Gooseman watched the two guards for a few moments. As they sat down at the table in the guard room, and started to play cards, he turned to Buzzwang. "What happened?"

"They ambushed us, Ranger Gooseman," Buzz answered. "Ranger Hartford and I were climbing down out of the vent shaft, to try and get into one of their computers, when they burst in the door and grabbed us. I think that, as Macross said, Daisy's agent told him we were coming. He must have been tracking us the whole time."

"I knew it was too easy," Daisy growled.

"Don't worry about it, Daisy, you couldn't have known..." He turned back to Buzz. "Where did they

take Doc?"

"Ranger Hartford and I were separated right from the beginning. Macross wouldn't admit it, but I believe that the disk contains some kind of information about the Rangers. They may have wanted Doc as a test subject..."

"This doesn't sound good..." Gooseman says with a frown. "That disk is starting to sound less and less like a minor inconvenience, and more and more like something that threatens us, personally."

"That's my conclusion, as well."

Gooseman glanced at the force field. "Well, now we have to get out of here. Anybody got any suggestions?" "Well, I could be disassembled," Buzzwang said, "and..."

Daisy put a hand against the blue indicator light that served as Buzzwang's mouth. "Shh!" She hissed, rather forcefully. She gestured up at a spot on the ceiling. There was a tiny, black, square object tucked up into the corner.

There was a moment a moment of dead silence, and then Buzzwang spoke, quietly. "I've run a scan of radio frequencies in the room. There is another, hidden behind that small vent."

Daisy nodded. "Added after I left the gang, no doubt..." She spoke louder. "Nice goin', Macross! You always were an cautious son of a bitch..." She stepped up onto the cot in that corner of the cell and pulled down the bug, then stomped on it with her boot. Buzzwang retrieved the other from the vent, and crushed it, as well.

"He'll not bother ta replace the bugs, since he knows I'll be watchin' fer 'em. Still, keep yer voices doo'n. There's bugs in the next cell, too."

Daisy gave Goose a provocative smile. "Nuthin' like a woman's touch, eh, Shane? Now, wha' do ye have in mind?"

## Chapter 7

Gooseman stared at the jumble of wires and oddly shaped metal components. Studying it for a moment, he finally picked out two wires, and started to twist them together with a couple of wires from another component.

"That won't work at all, Ranger Gooseman," Buzzwang told him. "You have the polarity reversed." He gestured with his left hand, indicating the proper two wires.

The android was sitting on the floor next to the makeshift contraption, his right arm limp at his side, and a panel on his chest open. The radio that had been embedded in his wrist now rested on top of the pile of electrical parts, a couple of cables running from it to a panel on the wall, where Goose had hooked it into a

small box next to the power lines that ran to the lights in the cell.

"I'm not sure I want to risk this, Buzzwang. If I have this wired up wrong, we could damage your components. I'm not sure I want to take you apart if I can't be sure I can put you back together again."

"We can't generate enough power to counteract the frequency of the force field without one of the power supplies from my body. I will have to be shut down for you to remove it. But, I have confidence in you, Ranger Gooseman. I was able to guide you this far, and you will be able to take it from here on your own."

Gooseman stared at him for a moment, then nodded. He looked up at Daisy. "Anything?"

"The guards are busy with their card game," Daisy stated, watching them from her position next to the force field. "I don't think they care what we're doo'n."

She chuckled. "It's a good thin' I'm no' in charge any more. I'd skin 'em alive fer being tha' careless. Especially since Dog-face has already goofed up twice today."

"Right now, I'm glad Macross isn't as strict a leader," Goose said. "Okay, Buzz, I think I've got it. Go ahead and shut down."

Buzzwang settled into a comfortable position, and then slumped over. Goose opened up another panel on his back, then reached in and pulled a large, square box out of the android. He hooked a couple of cables from his device up to terminals on top of it. There was a low hum as the contraption powered up, but nothing else happened.

"There's not enough power..." Goose muttered, frowning. He made an adjustment to a few of the connections, but the force field still remained unchanged. As he stared at the device, a commotion suddenly began outside the cell. Something crashed to the floor, and loud shouting began from the guard room.

"We've got trouble!" Daisy hissed. "One o' the boys jus' caught the other cheatin'!"

Goose turned to look, and as the little dog man ducked a thrown chair, he suddenly spotted Daisy watching them. At that moment, there was a crackle of energy from the device, and the force field began to flicker. Goose tried to shut it down, but it was too late. Both guards were charging down the hall towards them, and although bright flashes of light began to play across the surface of the force field, it was still solid.

"Aw, HELL!" Goose growled. Leaping to his feet, he grabbed the two power cables from the wall and pulled them loose, ignoring the sparks. He then jammed the cables against the terminals on the power supply. The force field flickered and faded out, while the makeshift device spit out a shower of sparks. All of the lights in

the cell block went out, and Daisy and Zozo leaped into the hallway.

As the first of the guards reached him, Zozo grabbed him by the shirt, flipping onto his back as he threw the lumbering gang member into the cell. He slammed into Gooseman, who was thrown back into the open panel, and both men were caught in a discharge of electrical energy. Gritting his teeth against the pain, Goose threw himself away from the panel, dragging the gang member with him.

Daisy, meanwhile, reached down to her belt, and with a snapping action, freed a long, slender line that was hidden in it. Swinging it around her head like a lariat, and she threw it at the dog-like gang member, snagging his rifle. The whip line immediately retracted back into Daisy's belt, pulling the weapon right to her hand.

Daisy opened fire on the little alien, grazing his leg as he turned to head back for the guard room. He stumbled, but kept going, obviously to sound the alarm. Just before he reached the door, however, a second laser blast caught him, and he hit the floor.

Gooseman lowered the other guard's rifle. He looked down at the fellow, still laying unconscious next to him.

"Good shootin'," Daisy told him, giving him a thumbs up, but Goose frowned.

"I only hope I didn't do too much damage to Buzzwang. At least his device seems to have successfully shut off the alarms, but it didn't have enough power to kill the force field. I had to use the raw power right from the wall."

Daisy helped as he wired the last of the components back into Buzzwang's body. The android sat up, looking around. Noticing that the force field was down, he nodded in satisfaction. "It worked."

"Not exactly," Goose countered. "Are you all right?"

Buzzwang looked up at him. He paused a moment, then sort of swayed backwards. "A number of my circuits have suffered an overload. My balance centers seem to be impaired. I am attempting to compensate, but I may need help in order to stand."

The android put out a hand to steady himself, as Gooseman helped him to his feet. Eve stepped up to take his hand, and then hooked Buzz's arm over her shoulder. "I can help him, Shane," she said.

"A very rational idea, young lady," Buzzwang said.

"All right. Eve, you're with Buzzwang." Gooseman walked to the door of the cell and looked out, the guard's rifle at the ready. He then looked back at Daisy. "I hope you know another way out of here. I kind of doubt Macross will fall for the vent shaft trick twice."

"So do I, Shane, so do I..." Daisy was staring at the fallen dog man, thoughtfully. As Zozo came up behind her, she looked down at the little blue alien, and smiled. "But I think I have an idea..."

\* \* \* \* \*

Macross scowled at the video screen, from which Ryker Kilbane smirked at him. The human could be maddening, at times. "You and I both know what that cargo means to our employer. She's paid us well for our services, Kilbane. Let's not get greedy."

"Gooseman is mine," Kilbane protested. "I owe that runt, big time. And I mean to pay him back. \*I\* will be the one to kill him, do you hear me?"

"And if she finds out we're holding out on her..."

"Do you think I'm afraid of the Queen of the Crown?" Kilbane asked, his voice mocking. "I'm a Supertrooper..."

"KILBANE!" Macross interrupted. "Not over an open channel! Not even a scrambled one! You know what her orders were!"

Kilbane's sneer increased. "You ARE afraid of her." He laughed.

"And you're a fool." Macross raised an eyebrow. "All of you Supertroopers are. So sure that your powers make you invincible... even Gooseman. But at least Gooseman isn't stupid enough to underestimate the Queen..."

Kilbane laughed again. "Holding the 'Ranger Boy' was your idea, too, Macross." He imitated the gang leader's gravelly voice perfectly. "That's why you're perfect for this plan. You hate him almost as much as I do."

"Just make sure your cargo gets to Tortuna... BOTH of them. Our orders were to bring her a Ranger, and we can provide one, AND keep Gooseman for ourselves. Just make sure she doesn't find out..."

He was interrupted as a gang member charged into the control room. "Macross! The prisoners have escaped!"

"WHAT!" Macross looked panicked for a moment, but then regained control. "All of them?"

"All of them, sir!"

He whirled back on the video screen. "How close are you to Tortuna?"

Kilbane smirked again. "An hour, maybe less. Is that runt too much for you, Macross?"

The tan-skinned alien leaned over the screen, his red eyes flashing with anger. "Look, Kilbane, you let me worry about Gooseman and you GET THAT DISK TO THE QUEEN! If Gooseman finds out where you're going, he'll be after you in a second."

"Good. Let him come."

"Kilbane! If he gets that disk from you before you can get it to the Queen, she will have BOTH of us in a Psychocrystal before the DAY's out! I want that disk OUT of our hands and into HERS before the Rangers can get to it. And that means NOW!!!"

Kilbane chuckled. "I know what I have to do," He said. The screen went blank.

Macross turned back to the gang member, who backed away slightly, startled by the fury in his leader's eyes.

"All right, who let them get away?!!!"

"Um... why don't you ask HIM, sir... he WAS on guard..."

The gangster pointed at a figure standing by the panel, a short, brown, furry alien in metallic armor. "You!" Macross said, to the dog man, who had his back turned. The little alien slowly turned, to look at him. But as the little fellow turned around, it turned out that his face was blue, not brown, and he had long, pointed ears and big, round eyes.

"Gotta run!" Zozo said. Leaping onto the computer panel, he threw a switch. Alarms began to blare in the control room.

Daisy threw off the cloak of the other gang member, and opened fire with the man's rifle. Zozo darted out of the room, under cover of Daisy's laser fire, as the Black Hole Gang dropped to the floor.

"They've unlocked the security overrides on the hangar!" One of the men yelled out, as Daisy disappeared down the corridor. "The Ranger and the android have captured Daisy's fighter!"

"After them!" Macross pointed down the hall, directing his men after the escapees. "After them! The man who brings me Daisy's head KEEPS his!"

"Too late, sir. Daisy and the Kiwi are in the hangar."

"Lock all hangar doors!" Macross grabbed at a console as a massive explosion rocked the asteroid. "What was THAT!"

"They've blasted out the hangar doors, sir! They're gone!"

Macross slammed his fist down on the console. "And now, thanks to Kilbane and his FAT MOUTH, they know that the disk is headed for Tortuna!"

He paused only a moment, to let his rage build up. "GET ME KILBANE ON THE LINK! NOW!!!!!"

## Chapter 8

The Rangers climbed out of Daisy's golden Interceptor,

while Daisy gazed out over the bleak desert landscape with a pair of binoculars. They had landed in an empty canyon, well away from the outskirts of Tortuna. It would be a long way to the only major city on the outlaw planet, but if it kept them hidden from the eyes of the Crown, a long walk would be worth it.

Buzzwang took a few experimental steps, testing his balance. "I seem to have regained some mobility, although my balance is still not 100%. But I believe I will no longer need Eve's assistance."

"Good," Eve put in. "You're one heavy bucket of bolts..." She then grinned at the android. "But I'm staying close by just in case."

"That would be for the best," Buzzwang agreed. "I will be better able to protect you if we are attacked."

"We've got company," Goose growled.

"You've got good eyes, Shane," Daisy commented, lowering her binoculars, as a cloud of dust appeared near the end of the canyon. It sped towards them, but the Irish outlaw didn't seem worried. "That's just me friend comin'," she said, "don't worry."

Within moments, a small cart had pulled up next to them. A purple alien with antennae sat in the driver's seat, while a yellowish fellow with big ears and a trunk sat next to him. Gooseman started as he recognized the passenger. "Geezy?"

"I thought it might be you Ranger hummings, when Afgar told me hummings were coming to Tortuna. Only Ranger hummings are foolish enough to come here."

"I'm no Ranger, an' I come here," Daisy said. "What's this guy doin' here, Afgar?"

"I went to him for the stuff you wanted, and he insisted on coming along. He's okay, I often go to him for stuff that I can't find."

"Your reputation preceeds you, Geezy," Goose said.

"I hope not," Geezy protested, making a trumpeting sound through his trunk. "I'm not here, remember?"

Goose chuckled, but the purple alien had climbed off of the wagon, and was opening up the back. He tossed some robes and body armor to the Rangers. Goose laughed again. "Zanquils?"

"They look a little like humans, so we can pass fer 'em," Daisy answered. "Can ye think of anything better, Ranger?"

"Not at all," Goose said, putting on the armor. "It just so happens that WE use Zanquill garb, when we come here..."

"I figgered ye might," Daisy said.

\* \* \* \* \*

"Zozo, you and Buzz scout out the back," Goose said. They were standing in front of a bar near the edge of the spaceport dome. The Kiwi nodded, and pulled his hat down over his long ears, vanishing into the alley with his two allies. Zozo had grabbed the hat just to avoid unwanted attention, but it was his human friends who needed to hide under the full costume of Zanquil traders.

As Goose and Daisy made their way into the bar, however, a figure in the shadows spotted them, despite their disguises. He slid off of his barstool and glanced back at them, and Goose recognized Kilbane's sneer under the dark hood he was wearing. The renegade Supertrooper took off in a run, headed off down a passageway leading into the back rooms of the establishment.

Ryker was grinning wickedly, as Goose burst into the room, Daisy right behind him. "You shouldn't have come, runt. Now I've got you right where I want you." He was holding a small device in his hand, and as Goose came at him, he pressed a button on it.

Goose suddenly cried out in pain, putting his hands to his head, as his badge erupted with light. Ryker laughed maniacally, as his old enemy staggered backwards. Daisy's blaster was in her hand in a second, but Goose was already collapsing to the ground. The sound from Goose's badge had become an ear-splitting shriek, and his head was wrapped in a nimbus of overloaded power.

Before Daisy could even fire her weapon, though, the device in Kilbane's hand suddenly spit out a shower of sparks, and smoke began to pour from it. Kilbane shook the device, slapping it against his palm, but it was unmistakably dead. The whine from Goose's badge returned to its normal, musical tone, and the soft, yellow light played across his face and up to his temples. Breathing hard, Goose got back to his feet.

"Damn!" Throwing the device aside, Kilbane leaped at Goose.

"I'm bringin' you in, Kilbane!" Goose snarled, as the Supertrooper locked hands with him. The two men struggled for a long moment, while Daisy watched her blaster at the ready. As Goose started to get the upper hand, however, Kilbane's hands suddenly changed their texture, becoming metallic and ridged. Shane gritted his teeth as electricity began to arc between them.

With a loud, enthusiastic yell, Zozo charged into the room. He threw himself at Kilbane, knocking him away from Gooseman, and the discharge of electricity sent all three of them reeling. The two Supertroopers struggled back to their feet, however, and glared at each other.

Gooseman put a hand to his badge, but there was only a faint, fading sound, as the badge's glow went dead. Goose tried again, but his implant was clearly exhausted. Kilbane smirked and took a step forwards,

but then staggered back, as if he were about to pass out. He glanced over at Daisy, sizing her up, as the outlaw leveled her blaster at him.

"See ya, runt," Kilbane sneered. He suddenly turned and leaped out the window, shattering the glass. The renegade Supertrooper landed sprawled out in the alley, a loud snap echoing off the brick walls as his leg twisted underneath him. Ryker staggered back to his feet, a glare of yellow light playing across his leg as his power healed it.

Swaying slightly, Kilbane looked around. In the doorway to the inn, further up the alley, he spotted Buzzwang. The android shoved Eve behind him, to protect her, then clenched his fists, as he waited for the Supertrooper's attack.

Instead, Kilbane held up a computer disk. He then brought up his other hand, showing Buzzwang that electricity still arced across it. "Make one move, Galaxy Ranger, and I'll wipe this disk... and you'll NEVER find out the secret about your friends' implants!" As Buzzwang drew back, cautiously, Kilbane turned to run.

Before Kilbane could take two steps, however, a cloaked figure stepped into the alley, blocking his escape. It was a tall, robed figure, dressed all in white, its face shrouded in blackness -- a Slaverlord.

Half a dozen Crown Agents in their bright red armor came up behind their overseer, as Kilbane stared at the Slaverlord. He looked uncharacteristically stunned by the unexpected appearance. As he stood, his mouth agape, the Queen's beautiful, yet harsh face appeared in the robed being's cowl.

"You fool!" The Queen's voice said, imperiously. "I told you not to make a copy of the disk, and you disobeyed me! And now, you have as much as given its secret away to the Galaxy Rangers! Your bungling has put my entire plan at risk! If that disk falls into the hands of the Rangers, Ryker Kilbane, I will see you in my Psychocrypt!"

The robed figure pointed at Kilbane. "Guards, take him... and destroy that disk!"

Kilbane moved quickly, seizing his one chance to save his skin. Throwing the disk high in the air, he darted forward, ducking between the Crown Troops as they scrambled to catch the disk. Leaping at the Slaverlord, Kilbane reached into its chest, pulling its crystal free, and the being shimmered and faded away. Kilbane tossed the crystal in another direction as he made his escape, disappearing into the crowds that filled the streets of Tortuna.

Buzzwang turned his attention from the fleeing Supertrooper to the Crown Agents and the disk. In their hurry to grab it, the soldiers had only gotten in each others way, and the disk had bounced out of their hands, and into a pile of garbage in the corner. A couple of them were digging through the rubbish, though, and it wouldn't be long before they found it. Kilbane's words had confirmed the android's suspicions, and he knew he had to recover that disk.

Before he could move, however, Eve grabbed his shoulder. "Ranger Buzzwang!" she yelled, apparently frightened. Buzz looked up in the direction she was pointing, to see Gooseman and Daisy O'Mega plummeting towards them, from the window above.

As they fell, however, Daisy triggered a switch on her belt, and her boot jets fired. Goose opened fire on the troopers with his free hand, his other arm around Daisy, as she slowed their descent. As the Ranger and his unorthodox ally landed, firing wildly into the Crown Troops, Buzzwang saw his chance.

Sprinting forward to the pile of rubbish, Buzzwang modulated his vocal circuits, perfectly mimicing the sound of a Crown Agent's rasping electronic voice. "I'll get the disk, Commander," he said, noting that the Agent's armor was that of a leader unit. "You should make sure the Rangers don't get our Queen's crystal."

As he expected, the Agent didn't even look up at him. "Yes. Good thinking, soldier," the commander said, turning to open fire on the Rangers. Buzz quickly grabbed the disk, which he'd been careful to watch as it flew across the alley, and then ran back the way he came.

He only got a few steps, however, before one of the circuits in his leg blew out, pushed beyond its limits by his rerouting of power. He staggered a few more steps, then tumbled to the ground. Rolling, to keep his momentum going as he fell, the android scrambled the rest of the way down the alley on his hands and knees.

"The disk!" The commander had figured out that he'd been tricked. "Get that Ranger!" Daisy and Goose dropped behind a bunch of trashcans, and provided the android with cover fire, as Eve darted out of the shadows of the doorway. The teenager grabbed Buzz by the arms as he reached her, and the two of them somehow managed to get back to the shelter of the building without being shot.

"Ranger Gooseman!" Buzz called out, as the Crown Agents blasted chunks out of the wall beside him. "We seem to be pinned down!"

"Tell me about it!" Gooseman's voice replied. There was a moment of silence, broken only by the shrill sound of laser fire, and then Zozo called out from the window above them.

"Incoming!" He yelled. There was a short pause, and then a massive explosion shook the alley. The laser fire stopped.

"What was that?" Gooseman yelled, somewhat stunned.

"Grenade!" Zozo replied. "Kilbane had about three of them!"

"Three... ?" Gooseman's question was interrupted as another loud explosion rocked the alleyway. Suddenly

the Crown Troops were gone, scattered in all directions.

There was a moment of silence. Then Zozo's voice drifted down from above, a bit quieter this time. "Actually, there were only the two. But I figure, what they don't know..."

## Chapter 9

Doc got to his feet, putting a hand to his head. He had the grandmother of all headaches, and the sinking feeling that things were only going to get worse. Sure enough, as he looked out at the room around him, he realized that he was in one of the Queen's prison tubes. "Awake yet, Galaxy Ranger?"

Standing below the tube was the Queen herself. There was no mistaking the purple tone of her skin, the harshness of her almost beautiful face, the vivid red of her royal robes. She regarded Doc with a mocking smile.

"Out of the frying pan and into the fire!" Doc exclaimed, as he pressed his hands against the glass.

"I hate to fall back on cliché's, Queenie, but you won't get away with this! Your pals Macross and Kilbane betrayed you! Gooseman knows where I am, and he'll be here any minute!"

The Queen laughed. "I know about Macross and Kilbane's stupidity. It won't help you. If Gooseman comes to rescue you, he'll be caught like the rest of your friends, and if he doesn't, he'll be all alone. He'll be easy enough for me to track down."

With a sweep of her cape, the Queen of the Crown turned back to a console on the other side of the room. Adjusting a few dials, she brought up the image of a Ranger craft on the display.

"My Gooseman!" Doc said with a grin. "I told ya!" The Queen chuckled. "That is not Ranger Two, Hartford. It is Ranger One. That is the ship carrying your two other friends, Foxx and Niko."

Doc stared at her for a moment, uncharacteristically silent. "My agents planted a homing device on their ship, so I would know the moment their mission was over, and they had lifted off. I do not want their concerns for a current mission to interfere in my plans..."

She turned back to Doc. "As you have guessed, Ranger, you will not be Slaverlorded. What good to me is a slave that can be killed, by remote control?"

As Doc's frown deepened, the Queen laughed. "You have, indeed, guessed the truth. Your own people, your trusted BETA, your 'good friends', they programmed you with a self-destruct mechanism."

The Queen put a finger to her temple. "BETA has planted a Time Bomb in each of your heads... and I intend to set it off..."

The Queen's mocking laughter was all that was left behind, as she left Doc alone in the room.

\* \* \* \* \*

"Okay, Buzz, what the hell happened?"

"I suppose you mean with the device that Kilbane had... Zozo, may I?"

The Kiwi handed Buzz what was left of the mechanism, and he sat down at the table with it. Zozo was looking out the window at the street in front of Agbar's bar, keeping an eye out, while Buzzwang examined the strange device that had almost killed Gooseman. Daisy seemed comfortable enough, though, settling onto a couch near the door. Apparently, she used this back room a lot, as a hiding place on her visits to Tortuna.

Kilbane's device was a ruined mass of shorted wiring, blackened with soot. "At the moment that you encountered Killbane, in his room, I heard a complex series of tones, transmitted on a radio frequency. They lasted nearly a second, during which you apparently experienced extreme pain."

Goose snorted. "The sequence was interrupted, apparently when the power supply shorted out on this unit." Buzzwang looked down at the device, pulling a few wires out to look at them more closely. "I do not think that the power supply Killbane used in this unit was quite adequate to the demand. It burned itself out before it could complete its intended purpose."

"Which was to kill me," Goose finished.

Buzz nodded. He pulled the disk out of his coat pocket, and stared at it for a moment. Then, as if making a decision, he touched his palm to the surface.

Being an android, Buzz's expression could not change. Yet, there was a slightly different note in his voice when he spoke again. "It is as we suspected. After the failure of the Supertrooper Project, the members of the Senate Committee on Extra Terrestrial Affairs put in place a safe guard on any future projects. That included the Galaxy Rangers project. The implants were programmed with a failsafe, to be used if any of the Rangers went renegade."

He looked up at Goose. "The signal that Killbane sent was a self-destruct signal, intended to cause your implant to overload, sending enough electrical energy through the tissue of your brain to cause immediate death. There is a lead shield in place, however, to prevent the signal from being sent accidentally, or by an enemy agent. The signal must be loud enough to penetrate the shield, and thus cannot be sent over more than a few yards... under normal power."

He looked at the device again. "Killbane's device was constructed of inferior parts, and thus failed before it could complete the signal. Even so, only your biodefences protected you. If you had been one of the other Rangers..."

He looked up again. "You would be dead."

Goose stared at him a moment. "Does Walsh know about this?"

"I doubt it. This appears to be a secret safeguard, added to any projects by agents of the Senate during the design process. I doubt that anyone at BETA knows about this."

"But Wheiner does." Goose growled. Eve sighed heavily, putting a hand to her head. "Don't worry about it," Goose told her. "Now that we know about this, we can get it removed. And if it was so secret, maybe your father didn't know about it, after all..."

The last was said primarily for Eve's benefit. Goose wasn't sure he believed it. "So how can we protect ourselves from this thing?"

Buzz shook his head. "I don't think there is any way. The signal must be so loud; in order to overcome the shielding already in your implant, that any other shield or jamming signal would be useless. It would take an INCREDIBLY powerful signal to jam it, at least twice the power of the signal." He held up Kilbane's device. "And you can see how much good it would have to have too little power."

At that moment, the door burst open, and their ally darted into the room. "Miss O'Mega!" He said breathily, "You should see this!"

He gestured for the others to follow, and they did, hiding in the shadows of the balcony above the main floor of the bar. As they watched, the face of the Queen of the Crown appeared on a monitor down below.

"My subjects!" The Queen said, her voice as melodramatic as always. "I am pleased to announce that I have captured one of the Human Galaxy Rangers..." The camera pulled back to reveal Doc, still held in a prison tube. He wasn't trying to break out of the tube, but looked around himself furtively, as if trying to find a way to escape.

Buzz inched closer to Gooseman. "This message is being broadcast on all subspace frequencies... including those used by Earth!"

"The Galaxy Ranger will make a fine addition to my Psychocrypt," the Queen gloated. "At noon tomorrow, he will become my strongest Slaverlord!"

Behind her, Doc suddenly threw himself against the glass. "Zack! Niko! It's a trap! Don't..."

He cried out as a field of electricity enveloped him, inside the tube. Then Doc slumped, unconscious. The Queen turned back to the screen. "My subjects, I declare tomorrow a day of celebration! Rejoice, for my victory is yours!"

The screen went dead. Zozo made a thoughtful noise. "It's not like the Queen to declare ANYthing a day of celebration. What's she up to?"



"Tha' wasn't meant fer her subjects, furry-face. That was meant fer th' Rangers."

Goose nodded. "That's got to be it. She's expecting us to mount an attack. The Psychocrypt is the perfect base from which to send that signal..."

"And with the asteroid field around the Queen's Graveyard dotted with those transmitters, she could blanket the whole area with the self-destruct signal." Buzzwang paused a moment. "And Pathfinder said that the transmitters are also programmed to detect any Ranger Ships in the area. So they not only echo the signal, but they tell the Queen when to send it, as well."

"Zack and Niko, of course, will ride right to Doc's rescue, and jump right into the middle of the field. They're as good as dead."

Daisy flipped the code key for her Interceptor into the air, quickly snatching it back into her closed fist. "Unless we get there first!"

## Chapter 10

"We should be out of range of Tortuna's tracking stations, Shane," Daisy said. Gooseman nodded, and switched on the subspace radio. In a moment, Commander Walsh's face appeared on the small viewscreen.

"Ranger Gooseman!" He said, somewhat surprised. He glanced down at the panel. "This isn't a BETA registered transmitter! Where ARE you?"

"On our way to the Queen's Graveyard, sir," Goose told him. "I'm using a borrowed ship. We were unable to use Ranger Two. Have you heard from Zack and Niko?"

"We just heard about the Queen's ultimatum a few minutes ago, Ranger Gooseman. Rangers Foxx and Niko are on their way to rescue Doc now. Do you want their coordinates?"

"Damn!" Goose slammed his fist down on the console. "Commander, the message the Queen sent is a trap! I can't say more over the radio, but I have reason to believe that she has discovered a weakness in our implants. You have to call back Ranger One now!"

Walsh stared at the screen for a moment, then turned away. He barked some orders to one of the officers behind him. After a few moments, an answer came back. From the look on his face, it was not good news.

"About five minutes after Zack reported that they were on their way, we lost contact with Ranger One. At first, we thought it was a malfunction. We've been trying to re-establish contact, but nothing seems to work."

"Damn," Goose said again. "It's too much of a coincidence, Commander. The Queen's agents must have sabotaged the communications on Ranger One.

We'll have to try and get there first."

"I believe that the Queen has set the... trap... to be triggered by Ranger One's engines, when it comes out of hyperspace." Buzzwang was sitting in the seat behind Goose, and leaned forward so that Walsh could see him. "We should be safe, in this ship. This ship also has jamming capabilities, so we may be able to get into the Queen's Psychocrypt without being detected."

Goose nodded his agreement. "Send me the information on where they were when you lost contact..."

Walsh uploaded the data, as Goose continued. "One more thing, Commander. Don't let ANYONE know about this conversation. Most particularly Senator Wheiner. And keep an eye on him... I will explain once we're all safe."

The Commander nodded. "Understood, Goose. Be careful." The screen went black.

Zozo leaned forward for a better look, as Goose studied the output on the viewscreen. "They're on their way?" He asked. He, Eve, and Buzz had taken the back seat, while Daisy, of course, was at the controls.

"Yeah. According to this, Ranger One will be about an hour behind us all the way. We're closer to the Queen's Graveyard than they are, but that still doesn't buy us much time."

"Can't we intercept them?" Zozo asked.

Daisy shook her head. "Not in Hyperspace. We'd need a Hyperdredge, or something like that, to net a ship in Hyperspace. I do have a couple of warning beacons, though. Maybe we could drop one in Ranger One's path..."

"If Walsh can't get through on the radio, they wouldn't be able to pick up a subspace beacon. The Queen's made sure we can't contact them through NORMAL channels."

"Maybe this can help." Zozo brought the second device out of his pocket. "It seems like Killbane had a backup. Maybe we can drop IT in their path. Careful with it, though, we don't want to set it off..."

"You're not kidding," Goose muttered, as he took the little hand held unit. He held it gingerly as he studied it.

"That is not the same type of device," Buzzwang said. He leaned forward, as Zozo had, while Goose turned the small object over in his hand. "I do not believe that is even a transmitter." Buzz held out his palm. "May I see it?"

Gooseman handed him the unit. "No, this isn't a transmitter at all. It's a bioelectric field generator. It isn't anything like the device that activated your implant."

"Are you sure?" Goose asked.

"Yes. Just to be safe, though, I could activate it for a few milliseconds, to test its effect..."

"I dunno," Zozo cut in, but Goose held up a hand.

"No. We need to know all we can about what Kilbane was up to. Try it."

Buzzwang activated the device, then touched it to Goose's arm. There was a flash of light, but nothing else. Buzz studied the device for a moment more. Then, suddenly, he held it up, excitedly.

"Of course! I know what this is!" He turned a control on the device, then placed it on Goose's arm. He then pressed the switch on the top of the device. There was a whine of power, and Goose's badge flashed, as he suddenly morphed - into Eve!

"HEY!" Gooseman protested. Even his voice had transformed. Eve herself burst out laughing, as did Daisy, while Buzzwang quickly pressed the button again. Goose returned to his normal form.

"Sorry, Ranger Gooseman," Buzz said. "Clearly, this is how Kilbane was able to impersonate both you and Eve Wheiner. When I activated it the first time, it was set for your body form, which is why nothing appeared to happen."

"All right, all right, no harm done." Goose scowled at Eve and Daisy, who were still giggling. "This doesn't help us, though."

"Not true," Buzzwang noted. "Did you notice that your badge activated?"

"Yeah, it did, at that," Zozo agreed.

"The energy used by this device is far inferior to the power used by your implant. But it may still be enough to give you one more charge. According to the schematics on the Senator's disk, the implants always retain a small charge, even when exhausted. Otherwise, you could defend yourself from the self-destruct signal, simply by using up all your charges."

"When the device activated your bio-defenses, your implant activated on its own, much the same as when the Mindnet device activated Niko's charge. If I can cause the device to expend ALL of its charge into your body, it should impart a charge to your implant - at least enough to allow that residual charge to be used..." The android studied it for a moment. "But there may be some discomfort..."

"Don't worry about that. That one charge may be the one chance we have. Do it."

Buzzwang flipped the device over, and opened up its back. He then pulled out a small component and twisted a piece of wire in its place. Closing the cover, he adjusted the control, then placed the device once

again on Goose's arm. He pressed the button.

Goose winced, as a stream of yellow energy flowed up his arm, and into his badge. There was a faint crackling noise, and the musical sound of his implant powering up. Then the light faded.

Goose rubbed his arm. "There's no way of knowing if it truly worked, Ranger Gooseman." Buzz told him. "You won't know until you activate your implant, and if you do that, the charge is gone."

"Then we'll just have to hope..." Goose glanced out the window, at the red unreality of Hyperspace, flashing past them. "Like Daisy said, Hyperspace is a big place. Our only chance is to get to the Psychocrypt, and make sure the Queen doesn't send that self-destruct signal..."

\* \* \* \* \*

Doc pulled himself painfully to his feet. His body still ached from the shock that had knocked him out, but the room was empty now. Apparently, the Queen had left to take care of other business, after making her broadcast to lure Zack and Niko here.

Blinking his eyes to clear away the last of the spots, Doc looked around at the room outside his prison tube. The tube, of course, was made of a clear, but tough material, so he could see out, but not get out. He could see his CDU sitting on a table next to the big console where the Queen had displayed the image of Ranger One. His badge sat right next to it, and next to both of them was the disk!

Doc sighed. He had his suspicions about what was on the disk. It was clear that the Queen felt that the signal she had collected so far, he had no reason to doubt that. Doc only hoped that Buzzwang had managed to figure it out, as well.

"Come on, my Gooseman..." Doc said aloud. "You and Buzz are the only chance we've got."

He fell silent as he looked down at his uniform. The Queen had been smart enough to take his badge, and with it, his powers. If he was going to get out of this, it was going to have to be on his own, using his wits.

The hacker smiled. Nothing new about that. He felt around on the floor, finding a seam in the deck plate under his feet. He lifted it out, revealing the emitter that had delivered him the electric shock before. Crouching in the tube, he began to fiddle with the wiring.



Artwork by stanio (2)

## Chapter 11

Doc frowned, studying two wires carefully, as he crouched over a hole he had opened in the floor. "It's either the red one, or the green one." He muttered, "but which? Ah, well..." Reaching down among the components of the prison tube, he jerked the red wire out of its socket.

The hacker cried out in pain as the tube activated again, sparks of electricity crackling up and down the surface of the glass. Through sheer force of will, Doc managed to shove the freed wire against a bare terminal nearby. The power cable shorted itself out, with a loud crack, and the electrical field around him dissipated.

The tube popped open slightly, a cloud of smoke rolling out from the fried machinery. Doc shoved the tube up out of his way, and rolled out into the open. He lay still for a moment, trying to catch his breath. "Momma always told me not to play with live wires."

Brushing himself off, we walked over to the console, grabbing his badge and CDU. He then grabbed the Queen's copy of the disk. He shoved the disk into a slot and brought up the data, nodding as he scanned the file. He then pressed a few more keys, and brought up a schematic of the asteroid.

"Time to start walkin'," Doc says. "I won't get anything else from this terminal." He shut down the display, then ejected the disk, and put it in his pocket. He then crept up to the door, put an ear to it, and jerked back as he heard talking on the other side.

Doc put his ear back to the door. There were definitely two voices, the electronically altered speech

of Crown Troopers. One of them was trying to engage his partner in conversation, but apparently the second guard was not interested in chatting.

"Wish I'd paid more attention when I was here last." Doc looked around the room, hoping to spot a vent shaft or some other back way out of the little room. There was no way out, and the other prison tubes in the room were empty, so he wasn't going to be able to distract the guards with a jail break.

"These guys aren't going to be swayed by my charm and wonderful sense of style," Doc told himself. "After all, they think basic RED is a fashion statement." He held his nose. "Pew. So, come on, Doc, THINK your way out of this..."

\* \* \* \* \*

Nearer the surface of the asteroid, Goose, Zozo, and Daisy slipped down the corridors, Buzz and Eve a cautious distance behind them. Goose watched up and down the corridor, while the others filed into an elevator.

"Watch the floors," Goose warned, as they waited for the elevator to stop its decent. "The last time we were here, the Queen dropped us down a trapdoor. I wouldn't be stupid enough to think that she doesn't know we're here..."

"I never though I'd be goin' into this place..." Daisy muttered, looking around her at the small, rectangular room.

"Second thoughts?" Goose asked her.

"Ever since I decided to join this little team... You owe me one, Shane..." She gives him a wicked smile. "You're gonna owe me BIG for this."

The elevator stopped, and Goose leveled his blaster at the open lobby area. Finding it empty, he stepped out and scanned the area.

"Perhaps we should split up," Buzz put in. "It would be more difficult for the Queen to track us that way. Zozo and I could try and shut down the transmitter which the Queen is going to use to broadcast the signal, while you and Daisy rescue Ranger Hartford."

"It might be safer if you an' I split up, Shane," Daisy added. She glanced at Zozo. "No offense, fur-face, but if Gooseman an' I get captured, I dinna thin' you can get us free..."

"I 'dinna' think that myself," Zozo said with a grin. "I don't know the first thing about transmitters, so I could go with you or Goose to find Doc."

"Sounds good to me. You got something I can draw you a map on?"

Daisy dug around in the pockets of her spacesuit, and pulled out a scrap of paper, a cleaning bill to the

original owner of Daisy's ship. Goose sketched a crude map on it, then pointed to a spot on the map.

"If the room we saw Doc in is the one I think it was, it should be around here... Zozo, you probably know this place better than Daisy, since you were briefed along with the rest of BETA when we came back."

He looks up at Daisy. "Even so, I've only seen this place a few times, myself, and I wasn't in a hurry to see it again. That's why I'm not trying to point out likely places for guards, they're probably in different places by now..."

Buzzwang gestures at another point on the map. "Analysis of the layout of the asteroid from the outside would suggest that the sensor and transmission equipment are located on the upper face. I would expect our target to be near the transport tube to that area."

"... Which is nearer the surface than the Psychocrypt," Goose adds, "for all the good that'll do. Daisy, you take the map. I'll count on Buzz and his computer memory. All right, let's go."

Daisy nodded, and took the slip of paper, then she and Zozo took off down one of the passageways. Gooseman stared after them for a moment, then gestured Buzz and Eve to follow as he headed off in the other direction.

\* \* \* \* \*

"Real pretty", Daisy remarked, closing the drawer. The alien that lay inside it, unconscious, was of a type she'd never seen before. She wasn't sure she wanted to see it again.

"This is where the Queen stores her victims before she sends 'em to the Psychocrypt," Zozo told her. "The Rangers told me all about it after their first visit to this place."

"Well, we're ginna haf' ta turn around. This is a dead end." The Irish outlaw made a quick sweep of the room. There was only the one door that they'd entered through.

"Ya know," Daisy commented. "If I were this Queen, I wou' set a trap hereabouts, so if somebody in here thawed out, he wouldna be able to leave..."

Zozo thought for a moment. "If I remember correctly, when the Rangers first came here, they fell down into that pit trap right after discovering a Gherkin, frozen like that."

"They may ha' trigger'd an alarm. An' we may have just doon the same thin'. I'd better check for booby traps."

Zozo held very still, a look of rising panic in his round eyes. "Do you think it's okay to move?"

"If it isn't, it's too late now." Daisy scanned the room carefully, moving from drawer to drawer, checking up and the walls and even along the ceiling. "Still, don' go near th' door 'til I've had a chance ta check it. Most likely tha's where a trap would be."

"I'm not going anywhere!" Zozo said. "Wait..." He paused, one of his pointed ears cocking as he turned to look back at the wall. He was clearly listening to a sound out in the passage that went past the room. "We've got company!"

"Great!" Daisy pulled out her blaster. "We're sitting ducks in here." She glanced around, then up, at a grating set into the ceiling above her head.

"That's a vent shaft, I think," she told Zozo. "It's the only way outta here... but if I were Queenie, I'd have it trapped. Kin we fight our way out?"

Zozo shook his head. "There's about ten of 'em."

Daisy sized the little Kiwi up, and then turned back to the grating. "Then we can't fight our way out." She fired her blaster at the vent, and it swung open. "Come on, furry-face, I'll boost you up there."

With the outlaw's help, Zozo climbed up into the shaft, then turned around to help Daisy up. As a handful of Crown Troopers burst into the room, opening fire, Daisy leaped, grabbing the little Zivi's arm. He cried out as her weight pulled down on him, but somehow managed to keep his grip on the edge of the shaft, until Daisy could grab onto the opening and pull herself up.

"Come on, we've gotta hurry," Daisy snapped, as she scrambled down the vent shaft. Finding another grate ahead of them, she began to kick at it. As Zozo came up behind her, he sniffed the air, his eyes growing wide.

Daisy looked up, to see a cloud of gas rolling down the vent towards them. With one final kick, she knocked the grate open, and dropped into the room below.

Zozo dropped after her, and the two of them charged out of the room. By the time the guards arrived at the room, Daisy and Zozo were already long gone.

\* \* \* \* \*

Elsewhere in the asteroid, Gooseman readied his blaster. The two Troopers guarding the room in front of them were caught completely by surprise as he darted out of the corridor, taking out each with a well-placed shot. As he, Buzzwang and Eve stepped up to the fallen guards, he fiddled with one of their helmets.

The Ranger worked for a few more moments, then harumphed. With a tug, he pulled the Crown Agent's head off. He held it up, studying the circuitry that now hung from the Trooper's neck. "At least we've answered the question of whether they're androids or armored soldiers."

"Not necessarily," Buzzwang countered. "It could be that the Queen uses robot guards here in her Psychocrypt, because they are less prone to rebellion. She may also use robots only for the lower level Troopers, with living beings as the leaders."

Gooseman looked at him for a second, then shrugged. "Oh, well. It looks like we won't be using their armor now."

"Perhaps not... but I should be able to salvage the parts I need to repair my own circuitry."

"I don't think we should stay in one place for that long," Goose countered. "The Queen is probably tracking our movements even as we speak."

"I am not detecting any monitoring signals in the area," Buzz told him. "And we have been careful to avoid the sensors I have detected. For the moment, I think we are safe. But if you feel we must keep moving, I could perform some minor repairs while walking. Enough that I would no longer need Eve's support, at least."

"I don't mind," Eve protested.

"Yeah, but with Buzz repaired, we could protect you better," Goose told her. "It's dangerous enough for you to be here as it is. I would have left you behind on the ship, but I was afraid that you might be spotted. Then we'd have Doc AND you to rescue from the Queen."

Eve blanched as the Queen was mentioned. "Well, I know I'm safe with you, Shane."

## Chapter 12

Daisy crept stealthily down the passage. It wound around a few times, then finally ended, in a small chamber. Daisy held her weapon at the ready, as she entered the room, Zozo right behind her.

Zozo cried out as he spotted a Crown Trooper sitting in a dark corner, and Daisy leveled her gun at him. When he didn't move, however, she stepped closer. "He's dead," she said, putting a finger against his neck. She then lifted off his helmet. "He's been shot..."

"There's another one over here... it's a robot. The circuitry's all fried, and half of his head's gone."  
"This one's blaster's gone."

Zozo looked up. "Doc?"

"Could be." Daisy nodded, then walked over to examine the robot. "No, wait. This one was shot at point blank range, right in the head. In fact..." she looked over at the other guard. "... I'd say he shot the other guard, and then shot himself. See, his blaster's almost empty. He must have set it on max."

Zozo looked at the blaster, which was itself half melted. "What does it mean?"

Daisy stood up. There were several doors across the back wall of this room, as if it were a guard post. As Daisy opened the first of them, she realized that she was in the right place.

"It's the room we saw on the video screen!" Zozo said, peering around Daisy. One of the prison pods had been shattered, and bits of glass lay on the ground around it. Daisy walked over, and picked one of them up.

"Looks like Ranger Hartford didn't need our help after all!" Daisy said with a grin. She glanced around the room, then walked back over to Zozo. "Come on, furry-face. The guards haven't noticed he's gone, so we don't want 'em to catch us in here."

Daisy closed the door behind her as she and Zozo slipped out of the room, and down the dark passage. "Doc's been lucky so far, but when these two don't report in, the Queen'll know he's escaped. We have to find him before they do."

"Where do you think he'll go?"

"The transmitter, probably. If he knows about what the Queen plans for his friends, I kinda doubt he'd try an' escape. So I guess we need to join back up with Shane an' Buzzwang."

\* \* \* \* \*

Near the northern surface of the asteroid, Gooseman and Buzzwang approached the communications room. Two guards had been posted to watch the area, but Goose took them out with a couple of well-placed shots. These guards turned out to be human, but they had reached their goal. There was no need for disguises now.

As they entered the large chamber, however, there didn't seem to be anything out of the ordinary. Just several rows of consoles, some computer banks, and an open doorway into a machinery room behind. "So?" Goose commented. "Any idea which of these gizmos is the transmitter?"

Buzzwang looked around the room, clearly concerned. "I do not know... a device capable of generating the kind of power needed to flood this area with your implants' self-destruct signal should be fairly obvious. Yet I see nothing of that kind in here."

"You mean, we're in the wrong place?"

"I... I am not sure. It seems so." He walked over to one of the consoles, began to work the switches and buttons. Goose just stared about the room, fingering his blaster. Maybe he could fix a hovercar, or jury-rig a circuit to overload a force field, but he was way out of his league now.

"Yes," Buzzwang said, after a moment. "It seems that your initial impression was correct. The transmitter is located in Engineering, in the center of the asteroid. Apparently, it needed a direct connection to the power supply."

"Can you shut it down from here?"

"I am afraid not." Buzzwang typed a command into a console, and watched the results that scrolled past. "The device is controlled from Engineering. However, it is programmed to respond to an incoming message from the sensors scattered around the Graveyard, to detect the Hyperspace signature of Ranger One. That signal should come through here."

"So it may be possible to shut it down."

"Yes, but it would take time."

Gooseman looked over Buzz's shoulder at the console. "You didn't sound any alarms when you logged onto that thing, did you?"

"Of course not." Buzz managed to look insulted, even considering the limited motility of his metallic face. "I used a cryptographic cypher to break into their system and override the security on this console."

"Ah." Gooseman said. "Of course."

"Shall I attempt to shut down the incoming signal?" Buzzwang asked.

"Yeah." Goose nodded, and Buzzwang began busily typing commands into the keyboard.

\* \* \* \* \*

"Shane an' tha' bucket o' bolts android should a' reached the transmitter by now." Daisy commented. "Unless they got held up."

Daisy and Zozo continued down the passageway, the lady outlaw holding her blaster at the ready. "Well, once we track down Ranger Hartford, we kin get outta here."

"If I know Doc, he's headed for the transmitter, too."

Daisy shook her head. "No. He's goin' the other way -- toward the center of the asteroid. Maybe lookin' fer a good place to hide."

"That doesn't sound like the Doc I know," Zozo commented.

"Yeah, but, remember, as far as he knows, he's all alone on this rock. He doesn't know we followed him. An' he may not know abou' the booby-trapped badges. He may just be tryin' ta keep outta th' Psychocrypt until Zack an' Niko can rescue him..."

Zozo shrugged. "Maybe."

They fell silent for a moment, as Daisy stuck her head around a corner. She drew back, quickly. "We've been spotted! Half a dozen Troopers' 'r comin' this way!"

Daisy ran back in the other direction, the little Kiwi right behind her. They both drew up short, however, as another group of Crown Agents cut off their escape.

"This way!" Daisy yelled, pointing out a side passage. The two fugitives disappeared down it, the Queen's guards right on their heels. One of the Troopers stopped to speak into his wrist communicator.

"We've found the prowlers, Magesty. A woman and a Kiwi."

"Ranger Niko!" The Queen's voice sounded astonished. "Impossible! She is on Ranger One with Foxx!"

"No, it's not the Galaxy Ranger. She isn't wearing a Ranger uniform."

"Someone else, then. Hm. But the Kiwi must be Zozo. Take them both alive."

"Yes, Magesty," The commander shut off his wristcom and headed after his men.

\* \* \* \* \*

"What is this?" Buzzwang paused, looking at his display for a moment, then began typing in more commands. He studied the readouts intently, then redoubled his efforts, his manner almost frantic as he typed away at the control console.

"What's going on?" Gooseman walked over from the door, where he had been keeping an eye on the door. Eve was watching over Buzzwang's shoulder.

"There is some sort of a blip in the system. I thought at first that I was being tracked, but then it turned and headed away from communications. It seems to be searching for power sources."

"Doc?"

"It could be. I am attempting to isolate the blip now, but it is evading me."

Gooseman nodded. "It's got to be Doc. He must be trying to shut down the transmitter from somewhere else... maybe Engineering. You keep trying to catch that thing, and I'll go see if I can find him."

Buzzwang looked up. "I will have to stop work on shutting down the incoming signal."

"If we're lucky, that's what Doc's blip is doing. Do what you can to catch it, and if you can't, get back to work on jamming the signal."

"Right away, Ranger Gooseman," Buzz agreed. He continued his work at the console, while Gooseman slipped out the door into the hall, and disappeared down the passage.

Moments later, however, he charged back into the room. Activating the control to slide the door shut, he then pulled out his blaster, and shot the control panel. The Ranger then grabbed Eve and Buzzwang, and shoved them both through the doorway into the machinery room.

"Hide in there!" Gooseman hissed. "Don't come out for ANYTHING!"

His warning was punctuated as the sound of laser fire was heard on the other side of the door. A shower of sparks burst from the door as it was melted open. Goose leaped behind a console, and began to fire at the Troopers charging into the room.

He was able to take out two or three of them, but the rest swarmed around their fallen comrades, overwhelming him. He was forced to duck a hail of return fire, and then one of the men leaped over the console to face him. For a moment, Goose involuntarily reached for his badge. Then, thinking better of it, he slugged the Trooper instead.

As five or six of the Crown Agents began to join their ally, however, Gooseman was quickly subdued. Two of the armored soldiers held the Ranger, pulling him out into the middle of the room. Near the door, the other Troopers moved aside, as a tall woman in scarlet swept into the room.

"Galaxy Ranger Gooseman," The Queen said, smiling. "I'll have to make sure that Macross and Kilbane pay for their betrayal. But it is no matter. I was, of course, aware of their plot all along... and I knew that you would try and save your friends."

"Bring him to my Psychocrypt!" She ordered. "And fetch Ranger Hartford, as well. I want them both together when their allies arrive, and the self-destruct signal goes off."

As the Queen turned and headed out of the room, sweeping her cloak about her in a dramatic arc, Gooseman glanced back at the inner room. Buzzwang, back in the shadows, watched as his friend was taken away.

### Chapter 13

"So... Galaxy Ranger Shane Gooseman... once again a guest in my Psychocrypt." The Queen smiled as she regarded Goose, his arms held firmly by two Crown Troopers to either side of him.

"Do not worry... as I told your friend Ranger Hartford, I've no desire to create a Slaverlord, only to have it killed by remote control. I prefer to simply kill you."

The Queen walked over to one of her control consoles, to check an instrument, while Gooseman seethed. \*Just give me a moment\* he said to himself. \*That's all I need.\*

The Queen turned around. "So... Galaxy Ranger. How

does it feel to know that you're being destroyed not by one of my creations, but by one of your own?"

Goose snorted. "If you're trying to goad me, it won't work. I never had any illusions about how the Board felt about me. I never trusted them or Senator Wheiner."

"But your friends... you didn't expect them to betray your friends, did you?"

Goose was silent. As the Queen laughed, a second squad of Troops entered the Crypt. They had two prisoners with them, a red-haired woman in an orange-gold space suit, and a wildly struggling Kiwi. The guards weren't holding Daisy's arms, but two of the guards did have their blasters trained on her. The leader of the squad stood beside them, greeting the Queen as she walked over to study the new arrivals.

"Daisy O'Mega, I presume", she said, studying the Irish girl's face intently. "Macross mentioned you to me a few times. I suppose he should have expected you to help out the 'handsome' Shane Gooseman..."

"My Queen..." The Trooper began. It was obvious, from the way he averted his eyes, and the hesitation in his voice, that the guard had bad news to report. "Yes?"

He paused a moment more. "My Queen, the other Ranger... he is gone!"

The Queen suddenly looked infuriated. "What! That computer hacker is loose in my Psychocrypt! HOW COULD YOU LET THIS HAPPEN!"

The Trooper winced. "We're not sure, highness. He appears to have escaped the prison pod. Two of the guards were knocked out."

"FIND HIM!" The Queen roared. "And take her to the pod!" She gestured at Daisy. "I want a Psychocrystal made from her immediately!"

Now, Daisy lunged forward, but the two Crown Agents grabbed her immediately. As she struggled, the guards dragged her over toward one of the columns that dominated the room. Goose also tried to pull free, but the guards still held him fast.

"Now... Ambassador Zozo..." The Queen stepped over to face the little Kiwi, who was still trying to free himself from the Troopers holding onto him. "I told you that you would serve me, Ambassador. Your people will be mine again."

"Not if the Galaxy Rangers can help it!" The Kiwi cried, boldly. "And it doesn't matter if your plan succeeds! There will be others!"

"Brave words. But not very reasonable ones. If the humans do not trust these Galaxy Rangers, what makes you think they will recruit more? They are as

good as mine. Their own distrust of each other has been their undoing."

Goose snarled as the Queen looked at him. Across the room, Daisy was trying to pull free, but each step was bringing her closer to her doom. Goose steeled himself. If he was going to act, he was going to have to act now... But before he could move, an alarm sounded, and a red light began to flash on a console behind the Queen. She whirled to look at it, even as one of the techs called out. "My Queen! The sensors have picked up Ranger One! The Rangers are here!"

The Queen turned, her laughter one of triumph, as the sound of a generator powering up rumbled underfoot. A loud, high-pitched whine filled the room.

"Your time is up, Ranger Gooseman! And for your friend as well! He may have escaped my prisons, but he cannot escape the self-destruct signal!"

Goose gritted his teeth against the pain, as a flare of light erupted from his badge, but it was followed almost immediately by an explosion from the console. The tech leaped away as a shower of sparks erupted from his panel, and suddenly the lights in the room flickered and went out. Red emergency lighting came on, and the sound of shrieking metal shook the deck plates underfoot.

"What is going on!" The Queen shrieked, as the high-pitched whine of the self-destruct abruptly cut off. The light from Gooseman's badge faded, but erupted again, as he reached up to trigger his badge. There was a sputtering noise as the jury-rigged charge dissipated without effect. But the two guards, mistakingly assuming that the Ranger's charge had activated, let go of him.

Goose quickly slugged one of his guards and grabbed his blaster. With a well-placed shot, he took out one of the men holding Daisy. She kicked the other, then grabbed HIS gun. Gooseman and Daisy charged in different directions, firing, as the guards opened up on them.

The Queen grabbed Zozo, holding him as a shield. "Get them!" She yelled to her Troopers. "And get that transmitter back on line!"

"Sire!" One of the techs yelled. "Fires in level 15, 18, 25... and now level 12!" He paused a moment. "Gunfire in hangar bay 3! Troopers report a squad of Galaxy Rangers attacking! Wait, there are more in the Central Control!"

"It's a false alarm, you morons!" The Queen roared. "That hacker's in the system! Shut down those alarms, and track him down!"

"Right behind you, Queenie!"

Doc charged into the room, slamming into her. He grabbed Zozo, pulling the little Kiwi behind him, as he leveled his blaster at the Queen. She stumbled away

from the Ranger, gesturing with her hands as he fired, only barely managing to summon a shield in time. Doc's laser blast bounced off the field of purple energy, as it wrapped around to protect her from Goose and Daisy's fire as well.

But as the Rangers made a break for the door, the Queen found her own troops trying to duck behind the shield. "Get back out there!" She berated them, shoving the Troop leader out in the open to accentuate her point. "I don't buy you that Powered Armor for its looks you know!"

As the Troopers took off down the passage after the Rangers, the Queen turned back to her techs. "Get that transmitter back on line! I don't care if you have to use the last reserves of our battery power, and transmit the signal through your headsets to do it, but TRANSMIT THAT SIGNAL!!!!!"

The Rangers charged blindly down the hallway, Goose and Daisy firing at their pursuers as they ran. "Not bad, Doc," Goose commented. "You're timing could not have been better."

"Well, I had the transmitter set to blow the moment it detected Zack and Niko's ship. But I didn't program the security alarms, I didn't have time..."

"Must have been Buzzwang, then." Gooseman grinned. "I left him in the Communications Center."

Doc laughed, but then doubled over, stumbling, pressing a hand to his temple. Daisy managed to grab him before he could fall. "You okay?" She asked, helping the hacker with a supporting arm as he ran alongside her.

"Yeah..." He said tightly, grimacing as if in pain. "I can... handle it. We need to get outta here..."

"Not so fast," Goose said. "My biodefences protected me from the charge again. But you might not have been so lucky..."

Doc waved him off. "No, it's not that..." He stumbled again, but managed to keep the pace. "It's... it's Pathfinder. I didn't have enough charge to bring him back out, but I sent him into the machine anyway. He's... he's gone."

"Tha' little will-o-the-wisp thing?" Daisy asked him. "But he's just a program... isn't he? Can't ya make another one?"

Doc grimaced, putting his hand to his head again. "Part of him is code, yes... but part's in here." He tapped his skull. "Was in here."

He sighed. "I felt it... when I lost him. Since then I've been feeling a little dizzy... it'll probably pass."

Goose glanced back behind them. The Troopers were falling behind, and had stopped firing at them, but they were still in hot pursuit. "In that case, then, we need to



get you back to Daisy's ship, and get you out of here."  
 "An' I don' care what you say, Shane, tha' implant looked like it burned you a bit," Daisy added. "We need ta get the BOTH of ya outta here..."

"And Buzzwang," Doc added. "I'm not leaving without Buzzwang, he's the most valuable member of this team..."

Goose looked back at him, amused. "What makes you say that?"

Doc grinned. "Because right now, he's the only one of us that doesn't have one of these things in his head." He tapped his temple again. "Which means, as soon as we get back, he's the one who gets to punch Wheiner in the nose!"

The foursome took off down the passage for the Communications Center. Anyone overhearing them as they passed by would wonder, given the seriousness of the situation, why they were all laughing.

#### Chapter 14

As the Galaxy Rangers charged into the communications room, they were drawn up short at the sight of two Crown Troopers waiting for them. But the lead Trooper took off his helmet, revealing the metal head of Buzzwang. He began taking off the rest of the armor, while Eve ran past him towards the Rangers.

"SHANE!" Eve cried, running straight to Gooseman. She hugged him, tightly, seemingly unmindful of the bulky armor she was wearing. "I was so scared! When the Queen took you away... and then when I heard the signal go off..."

"It's all right," Goose told her. "I'm fine. Doc came through for us, and you and Buzz were able to cover our exit."

Buzzwang nodded. "Once I realized that Ranger Hartford had already sabotaged the transmitter, I was able to concentrate on the Queen's security systems. I have also downloaded extensive information on the Psychocrypt and its operational parameters."

"Come on, you guys," Doc yelled. "Let's get out of here before Buzz winds up wearing that uniform permanently -- and we get fitted for Slaverlord robes!"  
 "That is another point. This Crown Trooper armor should double as a space suit", Buzzwang said, handing it to Doc. "Since Gooseman, Daisy and Zozo are still in their suits, that'll save us having to go back all the way to the lateral port where we left yours."

"My luck's holding out," Doc said. He slipped into the uniform in seconds flat. "So let's go, already."

"Wait!" Buzzwang said, holding up a hand. "I also have someone here who wants to talk to you."

Doc turned to look at him, confused, as the robot's voice shifted into a much higher register. "Hey, Doco!"

The voice said. "Guess who?"

"Pathfinder?!!"

"I intercepted him in the computer system, searching for a power source," Buzzwang said. "Apparently he fled into the system when your charge gave out, knowing that he wouldn't be able to return to you without a physical form. I was able to download him into my system just moments before he dissipated."

The hacker held out his CDU, grinning widely. Buzz touched his finger to the I/O port, and the tweaker passed back into its "home" with a flare of blue light. There was a cacophony of greetings from the CDU as the other tweakers welcomed their ally back.

"Way to go, Pathfinder!" Doc told him. "It must have just been your physical form that I felt dissipate."

"Let's go, let's go," Zozo interrupted, jumping up and down. "I think I hear more Troopers coming!"

The Rangers raced back down the passageway toward the upper port elevator, Daisy and Eve bringing up the rear. They were able to make it back to one of the elevator tubes, but then an electronic voice came from behind.

"Galaxy Rangers, halt!" Daisy whirled, taking out the trooper in a single shot. As Eve and the others crowded into the elevator, Goose and Daisy provided cover fire. Then they ducked through the doors themselves, just before they closed.

"I think they've figured out where we are," Doc commented, as the elevator jerked to a halt. He ripped open the control panel, and stuck his CDU into among the wiring. "I may not have any charges left, but that doesn't mean the Doctor cannot operate."

After a few moments, the elevator began to move again. The doors slid open, and the Rangers dove out into the hall, Buzzwang shielding Eve's body with his own, as he pulled her to safety. The small room erupted with light, as the few Crown Troopers left to guard the portal opened fire, but the Rangers took them out quickly.

After a quick check of their suits, Doc threw open the portal, and the Rangers drifted out into space above the asteroid. "Me ship's over there," Daisy said to Doc, pointing at a smaller rock drifting nearby. "The cloak's on, so hopefully Queenie doesn't know where it is."

"No, but I think she knows where we are..." Doc pointed in another direction, as a pair of Crown fighters swooped down on their position. The Rangers were forced to duck back inside the entry cavern, as blaster fire ripped out chunks of stone from the asteroid next to them.

"Great," Daisy growled. "They got us pinned doon. One o' us is ginna have ta make a break for the ship, an' provide cover fire."

Gooseman frowned. "Well, time to get dangerous..." Doc triggered the comm unit in his Trooper uniform. "This is Agent 6 7/8, I have captured the escaped prisoners! I'll escort them back to the Psychocrypt, there is no need for further assistance."

"Nice try, Galaxy Ranger," came back the electronically altered reply, "but we know that you took two of our uniforms."

"Someone distract them!" Zozo shouted, excitedly. "I'll make a break for the ship, under the cover of the rocks! As small as I am, they might not spot me!"

"Good idea," Goose agreed. "Daisy?"

She grinned at him provocatively. "I'd follow you anywhere, Shane."

"Just keep down, or you might regret saying that," Triggering the jet pack on his red-and-white space suit, he shot out towards the approaching ships. Daisy followed a moment later, a streak of gold trailing just behind him. The two opened fire with their blasters, their shots useless against the armor of the fighters, but the ships were drawn off to chase them.

"Wish me luck," Zozo said, and rocketed off in the other direction.

"Good luck," Buzzwang answered.

"Mama always said there'd be days like this," added Doc. He pulled Buzz and Eve down behind an outcropping of rock, out of sight, while he watched their teammates take on the Crown Fighters.

Goose and Daisy, being much smaller and faster targets, succeeded in keeping ahead of their adversaries for a few moments. But then a stray blast came within a hair's breadth of disintegrating Daisy. The shot detonated, the concussion sending her spinning backwards, right into the path of the advancing fighter. At the last minute, Goose shot past, scooping up the unconscious outlaw and pulling her to safety.

But the fighter that had been following him had noticed Zozo's rocket trail. As the other ship kept up the pursuit of Goose and Daisy, the Crown Trooper banked his craft into a tight turn, and came at Zozo from ahead.

"Oh, Mothmoose pellets!" The little Kiwi shouted. "I'm in the soup now!"

A bright, four pointed blaze of red light opened just behind the fighter. The familiar blue and white shape of a Ranger ship burst into view. It opened fire on the fighter, sending it spinning out of control.

"Ranger One?!!!" Goose triggered his intercom. "Zack! Niko! Get out of here, quick! The Queen's set a trap, and it may still go off any second!"

"It's me, Goose," came ALMA's voice, through the intercom. "When you didn't return to Frontier, I set off trying to track you. And then when I intercepted the Queen's transmission, I came here."

"It's Ranger Two!" Buzzwang put in, unnecessarily. The Ranger ship swooped down to the asteroid, and Zozo zipped in help his friends aboard. The four quickly hurried into the airlock, even as ALMA extended it out to meet them.

With Zozo providing cover fire from the ship, Goose was able to make it to the ship with Daisy. She regained consciousness as he was pulling off her helmet.

"I owe you one there, Ranger." She said, somewhat contritely.

Gooseman smiled at her. "Don't worry about it. Let's just say I'm sure Walsh will give you that pardon after all the help you've been."

She grinned back. "He'd better replace my Interceptor, too. I don't have an AI to guide her home, like you do." "ALMA!" Goose cut in. "Circle around to the east face and drop a tractor beam on that gold-colored Interceptor, hidden behind an asteroid there."

"Shane." Daisy said, "You're too good to me."

"I'm just trying to keep you out of trouble," he countered with a grin. As he stood up and headed towards the control console, ALMA spoke.

"I have relayed the news about the self-destruct signal, and our escape, to Ranger One. They have set a return course for BETA."

"Then let's join them."

"Yes, Goose." The stars outside the windows turned a brilliant red, and shot towards the ship as they rocketed into Hyperspace.

## Chapter 15

Doc sat up, rubbing his temple experimentally. "Is there any pain?" Q-Ball asked him.

"No. It just feels a little... funny."

"That's to be expected." He looked over at the other Rangers as they also sat up. Goose was looking grim, and Niko somewhat relieved. Zack was looking the others over, as Q-Ball was, watching for any sign that the implants had not taken. On the other side of a glass window, Daisy, Buzzwang, and Zozo were also watching.

"Well, there's only one way to find out if the operation was successful."

Zack nodded. Triggering his badge, he was reassured to see the familiar yellow glow wash over his right arm. The other Rangers then activated their badges as well,

Doc pulling out his CDU to open his portal.

The tweakers zipped out into the room. "We're all A-OK, Doc-o!" Pathfinder squeaked, as he whirled around Doc's head.

The hacker grinned. "You just remember how close you came to being deleted. I'll remind you of this the next time you want to lag behind in some system 'Just one more minute'." He pitched his voice higher to mimic the tweaker for the last couple of words.

All four of them looked up as Walsh walked into the outer room. He said a few words to Daisy, then stepped through the door and into the inner chamber.

"What's the news, sir?" Zack asked him. Behind, Daisy and the other two Rangers also joined them.

"Well, Wheiner claims to have had no knowledge of what was on the disk. 'Project Failsafe', as he calls it, was supposedly put into place by his predecessor, with strict instructions only to read the disk if one of the Series 5 Rangers went renegade."

"I'd be concerned about what Wheiner considered 'renegade'." Goose muttered.

"Indeed," agreed Walsh. "The point is, I've got nothing I can pin on him. Most of the members of the Council on Extraterrestrial Affairs that were in office at that time are now retired. And those who were not are claiming, like Wheiner, that they were not aware of the exact details of the project."

"Well, at least Q-Ball was able to remove that 'feature'," Doc said, putting a finger to his temple.

Zack nodded. "The Queen will no longer be able to use it as a weapon against us. And..." He was interrupted as a brightly colored, female, teenaged whirlwind burst into the room.

"Shane!" Eve asked, hurrying to the Supertrooper's side. "Are you all right? How did everything go?"

"Everything's going to be fine," Goose assured her. "We were able to remove the self-destruct code from our implants."

"That's great," Eve purred, wrapping her arms around Goose's. He pulled back a little, obviously a little taken aback by her sudden affection, and looked up at Niko for help. To his surprise, she was scowling at him.

Daisy chuckled. Eve turned to look back at her, then looked at Walsh. "What about Miss O'Mega? Did she get that pardon?"

"Eve!" Goose protested.

"BETA has dropped all currently standing charges against Daisy O'Mega," Walsh said. To Goose's confusion, he seemed to be amused by something. But as he glanced at Daisy, his expression became more stern. "But this covers only current charges. If she gets

in trouble again, BETA will not extend the same courtesy twice."

"I'll be makin' sure ye won' have cause to," Daisy put in. "I canna say I'll no be BENDIN' the law a bit, but I'll steer clear of ye Rangers from nae on."

"Any chance of you staying and working for us?" Zack put in.

Daisy glanced at Goose for a moment, but then she looked at Niko. "No. I've lived that life. I dinna wan' ta go back to it." There was a short silence while she paused, thoughtfully, but then she looked up again, a mischievous smile on her face.

"Mind you, if SHANE asked..." Daisy paused for effect. "And he asked... nicely..." Niko's scowl deepened.

"Well, I'm glad you helped Shane rescue me," Eve cooed, pulling the Ranger a little closer. Shane made a feeble attempt to extricate himself from the teenager's grip, but she only held him tighter.

From his other side, Daisy wrapped an arm around his neck. "I was MORE than happy to help," she said, leaning in close to the Ranger.

Niko stood up, still scowling. "Well, if you will excuse me..." she gave Gooseman a withering stare. Goose just stared back, completely confused. "I'm SURE that I have better things to do."

"Wait!" Goose stood up, dragging Eve along with him, as Niko stomped out of the room. He followed, severely hampered by the affectionate teenager clinging to his arm.

"Interesting." Buzzwang commented. "I rescued her once, as well, but she did not demonstrate the same gratitude towards me."

"Oh, I dinna want ta miss this. This is ginna be WAY too much fun." Daisy quickly followed the two Rangers and the enamoured Eve out the door.

Doc chuckled. "Some guys have all the luck..."



# SATHAR BRIEFING REPORT

Tom Verreault/jedion357

**\*\*\* CLASSIFIED MATERIAL \*\*\*\***

*Report of the Sathar Summit; a multi-discipline think tank organized by the UPF, in conjunction with Star Law, the University of Zebulon, and the Rim Coalition.*

## INTRODUCTION

After two years deliberating over all available Sathar data, artifacts and specimens, the Sathar Summit has prepared this summary of its findings. The report is broken into three sections: Analysis of observed Sathar reactions to several races and civilizations, analysis of new discoveries, and finally recommendations for using this information against the Sathar.

## SECTION 1

The most well known reaction of the Sathar upon encountering another civilization is labeled the Sathar Shiva Response. It is an attempt to destroy advanced space faring competitors without prior communication. This strategy is consistently demonstrated in attacks on the Frontier and the Rim and by the destruction of the Saurian home world as well as the near genocide of the Eorna. In all cases this is the standard response to races and cultures possessing advanced technology and space flight. There is one exception to this is the Mhemne. But special circumstances within the Sathar civilization may be at play to cause that exception or it may be simply because they had no real military capability.

Races that are not exterminated are usually enslaved and manipulated for the Sathar's benefit. Current speculation is that the Zuraqqor are one such race that were either not a threat militarily or not capable of space flight upon first contact with the Sathar. Debate continues on the nature of the relationship between the Zuraqqor and the Sathar as to whether it is that of allies or master and servant. The autopsied specimens of Zuraqqor do not show evidence of Sathar bio-engineering but the results do not fully exclude that possibility.

The Mhemne race did possess both limited space flight and some high technology upon contact with the Sathar but it did not seem to be of a level to trigger the Shiva Response. Current thinking is that the Mhemne were being groomed as a slave or client species within the Sathar civilization.

Another famous strategy of the Sathar is labeled, 'salting the earth'. It was clearly documented on Zebulon after the near genocide of the Eorna, as well

as on some of the planets briefly occupied by the Sathar in the Rim and Frontier and is presumed to have been done to the saurian home world. It involves releasing large numbers of bio-engineered attack constructs like quick deaths into the ecosystem. On Zebulon it also involved establishing an automated listening post to detect and report the rise of a space faring civilization. As yet the level of space activity that triggers the automated listening post is undetermined but in light of the documented pirate activity in the Zebulon system it would appear that a single ship would not rise to the level required.



Artwork by Shell

When the Sathar prove unable to dominate, destroy or enslave a race or culture they formulate covert campaigns to infiltrate, subvert and steal technology (see appendix B for the comprehensive list of all known Sathar agents and appendix C for details on Sathar mind control). Between the 1st & 2nd Sathar Wars several attempts were made by the Sathar to steal or capture operational assault scout class ships; the most famous being the Osprey Incident in the White Light system.

## SECTION 2

Recent analysis of Sathar equipment and specimens taken in system FS30 indicates a clan structure within the Sathar civilization with inferior clans desiring to supplant the dominant clan. Currently there are only two confirmed clans and a third is hypothesized.

Since the Zuraqqor have only been encountered in conjunction with Sathar, conforming to the profiles identified as clan X it is presumed that they are a client/ally of that clan. It is believed that clan Y was grooming the Mhemne race as a client/ally to counter the balance of power of the clan X/Zuraqqor pairing. This suggests a greater amount of instability within the Sathar civilization than previously presumed.

The discovery of separate Sathar clans to the east and west of the Frontier is a development with serious consequences. It raises the possibility that the Rim and the UPF is a small island within a sea of Sathar territory.

In light of the well know Sathar suicide reflex that prevents capture of live specimens, it is now believed to be the product of genetic engineering. Thus, because of the apparent genetic engineering of different castes within the Sathar civilization, the summit has concluded that the whole civilization is controlled by either a ruling elite or an 'over-mind' that orders the whole society from the top down.

## SECTION 3

The Sathar Summit recommends against a full scale military campaign against the weakened inferior clan Y. It is believed that the Sathar's pathological fear of other space faring civilizations will results in a Shiva Response by all clans should we come close to eradicating any one clan in isolation.

The summit recommends an expanded scout service. It should be tasked with exploring and mapping all territory within twenty light years of the Rim and UPF territory. The primary objective will be to clearly establish the borders of Sathar territory and to identify any other Sathar clans. The secondary objective will be to locate another world that has undergone the "salting of the earth" strategy and to locate another automated listening outpost similar to the artifact on Volturnus. The discovery of another artifact of that nature presents a priceless opportunity to lure the Sathar into a trap.

A Sathar automated tracking net will be indispensable to the expanded scout service. Basically, we should take a page from the Sathar play book and leave an automated listening post in every system the scout service explores to report any space activity.

Efforts to communicate with the Sathar should also be increased. If there is dissention amongst Sathar clans, communication could be the key to turning the Sathar against themselves. In light of their known methods of subversion though empathy and telepathy, these may

be the best avenues to open communication. The summit recommends a joint initiative in this area between Star Law and SpaceFleet.

### Campaign and Adventures using the Sathar Summit Report

The player characters can join the expanded scout service. Rocketing around the cosmos on a five year mission exploring strange new worlds has proven to be a popular theme in the past and would provide endless opportunities. Scout ships could be the venerable Assault Scout with some stealth technology added on or a frigate class that could take the punishment of running into Sathar as it maps the boundary of Sathar territory.

The admiralty has ignored the summit's report by attempting to destroy clan Y while it is weak and the predicted Shiva Response was triggered in all clans bringing down the Sathar War III on the Frontier. This would be ideal for a strictly KH campaign but role play could be worked in as well.

The empathy/telepathy angle could be worked in provided the Sathar remain enigmatic even in communication. After decades or centuries of no communication with the Sathar, talking to them should not be like chatting over coffee.

A campaign or series of adventures similar to those in SFKH-0 (Warriors of White Light) could be run with the players sent to FS30 system (home of the Mhemne race) as military advisers. Adventures on the surface could involve hunting down Sathar bio-engineered attack constructs and locating pockets of Sathar or a listening post. KH scenarios could involve counter strikes by the Sathar.



Artwork by C.J. Williams

# THE MOTIVATION OF THE SATHAR

Chris Putnam

By Wjem Mecessaru (in seclusion at the Athulee Meditation Center on Groth)  
Transmitted on Wjem's Behalf by Chris Putnam

## INTRODUCTION

Before I begin, I must apologize to my fellow sentients: this forum is not the correct place to be promoting my theories on the motivation of the Sathar. Unfortunately, I have little choice; my position in a certain security think tank on Terledrom was terminated when my conclusions contradicted the rationale for the current UPF military buildup — a buildup supported by key bureaucrats responsible for my funding.

My thesis, though simple, defies conventional wisdom: the Sathar prefer to fight wars via proxy rather than participate directly in conflict. I will provide evidence for this thesis and logical next steps for the Frontier below. Readers must also forgive references to internal UPF documents (such as SFAD2) that are meaningless to most sentients, but should be sufficient to establish to those "in the know" that my conclusions are based on real data from real events and are not paranoid delusions.

## THE SATHAR USE OF PROXIES

That the Sathar use proxies to accomplish their military goals is quite clear from the available data. First, the Sathar military relies heavily upon technology (including their invasion and attack fleets [SFKH0, SFKH4] and robots [SFAD3]) as well as cybernetically and genetically modified servant species (including quickdeaths, slithers, slavebots, cyboslugs, and cybodragons) [SFAD2]. Second, the fact that capture of a live Sathar has only been reported once [SFKH3], to my knowledge, strongly indicates either a suicide policy or a lack of Sathar in the front lines of combat. Compare this single capture to the large numbers of captures, especially of pirates, during normal UPF activity [including SFAD2, SFKH1]. Third, recently declassified UPF documents indicate that a Sathar training base was found that was used to train members of Frontier races to infiltrate key bureaucracies and governments in the Frontier [SFAD3]. Finally, rumors of Sathar telepathic ability are also consistent with the training of intermediaries to infiltrate the Frontier.

But what has escaped the attention of both the UPF and the general public is that these proxies — these robots, servant species, and infiltrators — dominate the Sathar military. Unlike the UPF, the Sathar routinely deploy large contingents of robots and cybernetic creatures to do their fighting. Even the infiltrator

training facility was primarily defended by Sathar combat robots. Note that, to our knowledge, the capabilities of the Sathar robots do not differ substantially from those of similar robots in the Frontier — Sathar robots certainly have not reached self-awareness as have Mechanons. Thus, the willingness of the Sathar to use these robots in the place of Sathar warriors, despite their inherent limitations relative to sentient beings, reveals a fundamental difference in philosophy between the Sathar and the UPF.

## COUNTER ARGUMENTS

The conventional wisdom arguing for direct Sathar attacks is based on several important and well-known events: the First and Second Sathar Wars and the Sathar attack on Volturnus [SFAD2].

Are the First and Second Sathar Wars inconsistent with my hypothesis? In most cases, we cannot determine whether Sathar ships were directly crewed by Sathar or controlled remotely or by computers or servile races; however, I will assume Sathar crews for the sake of argument. Now, there are several possible explanations, but perhaps the simplest is that the Sathar, like all sentient species we now know, are individuals.

Conventional wisdom interprets the delay between the First and Second Sathar Wars as necessary for rebuilding the ships destroyed by Frontier forces. I believe that the delay is more correctly understood as the rise of a militant Sathar faction that rejected the slow "war by proxy" and demanded more radical action. This faction may be an independent entity or a political force within the Sathar government. Either way, I believe the Sathar have exhibited two vastly different responses to the Frontier and in doing so have demonstrated internal rifts that perhaps the Frontier can use against them in the future.

I also posit that Volturnus [SFAD2] was more important than explained by traditional accounts. Rather than an attempt to eradicate the already-dwindling Eorna population, I believe the attack was meant to prepare Volturnus as a staging ground for a full-fledged Sathar invasion of the Frontier. I would argue that the Zebulon University has been far too accommodating to the Eorna, who have requested that large sections of Volturnus remain under their control and off limits to even remote sensing by Frontier races. I submit that while the Eorna rightly enjoy a reputation as a peace- and art-loving race, this reputation could conceal individuals who have been recruited or coerced by the Sathar to assist in a military effort against the Frontier. If the Eorna have nothing to hide, then they should allow StarLaw or UPF personnel to freely

investigate these “off-limits” regions of Volturnus. In short, I suspect evidence of a Sathar military presence can still be found on Volturnus. I’d prefer to be proven wrong, of course.

## SATHAR PSYCHOLOGY

If the Sathar do in fact prefer to engage in “war by proxy,” what does this reveal about Sathar psychology? One possible explanation for the Sathar reliance on technology and intermediaries and the Sathar tendency to attack all other life forms is that the Sathar evolved from a prey species and not a predatory one. As a singularly vulnerable prey species (lacking both external armor and internal skeletons), we can conclude that their intelligence must have evolved to help the proto-Sathar avoid predators. As the proto-Sathar developed the ability to reason, they learned that lasting safety required extermination or subdual of all possible predators. Although the extinction of their natural predators was likely achieved many millennia ago, the “exterminate or dominate” response will have been deeply ingrained into Sathar culture. Thus, when the Sathar encountered other intelligent, space-faring species, their reflexive reaction was to choose between extermination or domination. The discovery of the Frontier must have been particularly horrifying; the Frontier’s technology was sufficiently advanced that neither extermination nor domination was easy. The Sathar have therefore initiated decades-long plans to overwhelm the Frontier through corruption via intermediaries developed on worlds distant enough from the Sathar that disloyalty could never directly threaten the Sathar themselves.

Neither we nor the Sathar proxies have seen the true face of our enemy yet.

## CAUTIONARY NOTE AND CONCLUSION

Despite the tone of this article, I am not an Anti-Sathar League fanatic; however, I do feel it relevant to point out that the Sathar know where the Frontier is, whereas we know nothing about the Sathar world(s). Evidence discovered at the Sathar training base [SFAD3] raises the very real possibility that Sathar infiltration agents have already learned and communicated much about the inner workings of the Frontier, where as we, to my knowledge, have no similar agents among the Sathar. Moreover, we have seen a dramatic increase in military conflicts between various mega-corps and cults that have distracted StarLaw and weakened the UPF. A very real possibility — one both StarLaw and the UPF continue to haughtily discount — is that some of these conflicts have been initiated and/or directed by the Sathar, and that more are coming.

Fellow sentients, I choose to end this analysis on a positive note, not a negative one. The menace of the Sathar and the effectiveness of their subterfuge is only enhanced by the secrecy of their agenda. Shining the

clear starlight of day onto what we already know makes the Sathar knowable and defeatable. Only together can we deny them their true, hidden goals. I urge you to go to your politicians and tell them that while building up the UPF forces is important, it should not be the top priority for the Frontier. Rather, the funds used for our defense should be used to root out the Sathar infiltrators and conduct extensive investigations into the motivations behind the conflicts within the Frontier itself.



Artwork by Scott Mulder

# THE VERSATILE ION DRIVE

Gary Cliff (BD Cerridwen)

## ...And Why You Should Have One

### SPEED

We all love it. We have sayings that glorify it such as "Speed kills!" or "Bigger, stronger, faster!". Atomic drives epitomize this point of view, and most of us look to atomics when designing our own starships for this very reason. Why would you want your ship equipped with anything else? Especially the antiquated, sluggish and slow ion drives? In this article, I will attempt to answer these questions. In so doing, I will also present some additional rules and equipment that you might want to adopt for your own campaigns.

### POWER

Am I joking? Power as a benefit to ion engines? Ion drives do not generate power like atomics do. In fact, they need power from another source in order to create the ionized particles they use for thrust. Some ships use a large array of solar collectors and massive batteries for this source, but that is only really practical on system ships or as an emergency backup. Where ion power really shines is if you think green and use a fuel cell. After all, you're already carrying a boat load of hydrogen, so this only makes sense. A hydrogen fuel cell is efficient and easy to maintain - well, easier than a nuclear reactor anyway. They can even be adapted to use biological waste to generate power. With a fuel cell integrated into the life support system you get rid of your waste and produce electricity, heat, and clean water. Al Gore would be so proud of you.

### COST

Business is business, and the bottom line is what is important. There are numerous ways in which the ion engine is cheaper than atomics. To start with there is the initial cost of the engine. The ion drive is about 1/4 to 1/3 the cost of the atomic drive fresh out of the crate (depending on size and SCC type). That is even before you consider the additional cost of the drive program. A set of the big Class C ion drives requires a level four, 24 function point program costing 24,000 credits. Compare that to the small Class A atomic drives that require a level 4, 36 function point program costing 36,000 credits. The Class C atomic drive program by itself adds 104,000 credits over the cost of the ion drive's most complex program. If you're building a bulk freighter or passenger liner, you're digging a big hole of debt right off the bat by going nuclear. It will take a lot of hauling to recoup those costs.

Another cost is that associated with jumping. Void speed is a constant 1% of the speed of light which is roughly 12,000,000 km/hr (200 hexes per turn). Assuming that the ship starts from a dead stop and

accelerates at a constant 1 ADF, it will take 200 turns (33 1/3 hours) to reach void speed. This means any given ion driven ship will use 400 units of fuel per engine to accelerate into and then out of void space. Multiplying by the cost of hydrogen (10cr per unit) and it costs 4000cr per engine per jump. Compare this to the 10,000cr cost of the atomic fuel pellet and already we are saving 6000cr per engine. We haven't even considered the other maintenance costs yet!

The need to overhaul atomic engines means an atomic ship is unlikely to travel without an engineer to perform the necessary regular overhauls. The simpler and more reliable ion drives, on the other hand, are often maintained by a technician or robot under the direction of the drive program. Overhauls can be assumed to be accomplished during the required annual maintenance period. A frugal ship captain can save a minimum of 20 credits per day by hiring a level 6 technician instead of a level 1 engineer. That's 8000cr per year! Cha-ching!

### SECURITY

Yes, you read that right. I am proposing that ion drives offer more security than the speedy atomic engines. This argument can be made due to the fact that: A) ion drives are invisible to long range energy sensors; B) they can make radar windows; C) readily available fuel; D) more weapons. Let's examine my thought processes here.

#### *Invisibility (Sort of)*

Don't discount the energy sensor invisibility factor to easily. Somebody hunting for your ship will have to get within radar range to find you. With the money that you saved on engines versus atomics, you could install your own energy sensor. This will allow you to see them coming (provided they're going atomic) and maneuver out of the way of their radar arc. The best way to not get caught is to not be found. And don't worry about the 100,000 credits, you'll soon recoup the cost of the energy sensor with the savings you have on each jump versus atomics.

#### *Window*

The rules regarding radar windows are a little thin and, in places, contradictory. In fact, the section of the canon rules that address the jamming of energy sensors contradicts itself within its two paragraph length! The very first sentence reads: "neither window nor decoys will fool energy sensors!". And the second to last sentence reads: "However, ships with ion engines are invisible to energy sensors." So at first it seems to say energy sensors can find any ship, but then it says that ion ships are invisible. Which is it?



Despite this apparent contradiction, it may be inferred that a ship with ion drives can not be targeted inside a window even by a ship with energy sensors. Only chemical or atomic engines of other ships hiding in the window can be detected by energy sensors (or if the designer of an ion driven ship was foolish enough to use a nuclear generator to power the ship). As energy sensors are designed to detect any "source of extreme heat", they might not be useful in detecting the relatively low heat output from fuel cells and life support systems, except at very close range. This leaves visual sensors as a search medium over an immense expanse of space.

Thinking three dimensionally, a single 10,000 km hex can be equated to a sphere of 5000 km radius. This is a massive 523,333,333,333 cubic kilometers of space! And that's using only one engine! A HS 20 ion propelled ship can fog a whopping 267,946,666,666,667 cubic km! Talk about finding a needle in a haystack. In the sidebar, I offer a set of rules that can be used to locate a ion ship in a radar window.

It should be obvious that the window itself is not invisible to radar. In fact, the cloud of ions is quite visible. If you happen to be using it around sensors that aren't expecting a ship, or are not being paranoid, it may only appear to be a cosmic anomaly - until it is sufficiently analyzed. But you won't be fooling anyone who knows that there's a ship in there. As a form of protection, the window is simply a way to buy time. To the typical freighter or passenger liner, time is their friend as they try to wait out a pirate attack until the local system militia or Star Law can show up to help. Note that any ship within the window will have its radar fogged too. Again, you might want to consider using some of the money you saved on drives to install an energy sensor on your ion driven ship.

Another thing to consider is mine fields and seeker missiles. If you need to infiltrate a mined area, it can be assumed that using an ion driven ship is the way to go. As stated before, a single hex is HUGE and no ship could carry enough mines for them to detonate on contact. They must have some sort of proximity detector, either radar or energy sensor. As noted above, ion driven ships are virtually invisible to energy sensors, and a windowed ship cannot be targeted by radar. Thus a windowed ion ship could slip right through the field of mines and/or seeker missiles. I've always assumed that minelayers are ion driven ships for this very reason.

### **Fuel**

Hydrogen is perhaps the most common element in the universe. The engineering deck of a ion driven ship could carry a scaled down mining processor and a small fleet of heavy duty digger robots (if not a full digger shuttle) that can extract hydrogen or other fuel material from asteroids, moons, or possibly even the atmosphere of planets. It's safer to boldly go where no one has gone before when the gas stations are already there.

### **Weapons**

I'll bet that you were surprised by the 'more weapons' item that I listed earlier. But think about it. You're already limited to 1 ADF so why not use those ADF points that you 'lost' to pack in more weapons? The rules are vague on this issue, so take advantage of it. Normally your atomic powered hull size six freighter will be limited to a single laser battery before suffering the effects of the MHS limitations. Put ion engines on that baby and suddenly you have 3 laser batteries without a performance hit. The two points it would cost would be the two ADF points you 'lost' for using ion drives. Some referees might not agree with this method, but you'll never know until you try!

### **SUMMARY**

There is rarely a Star Frontiers enthusiast who would use an ion drive after experiencing the raw power of atomics. Yet ion designs have proven their utility in the Frontier and remain the most economical drive for interstellar travel. After my investigation, I found that many more of the ships that I design these days are driven by ion engines. After learning of their utility and versatility, I hope some of yours will too.

### **SIDEBAR 1 - ION WINDOWS AND DETECTION**

I'm not an astronomer or optical engineer, so the rules here are guesses based on data that I've collected from persons who at least seem more knowledgeable than me. The basic system is that the further away you are and the less complex your astrogation equipment, the longer it will take to locate a windowed ship. A searching ship requires at least System level astrogation equipment and a level 4 Analysis program. If the Astrogation program is also level 4, then the searching ship also needs a Bureaucracy program to coordinate the two.

If the windowed ship can target a searching ship (due to energy sensors or tracking it with astrogation gear), it may fire upon it. However, doing so runs the risk of giving a searcher with energy sensors a clear trail to the section of space where the shots originated. Each turn that the searcher does not find the windowed ship and the ship does not attack diminishes this chance. Repeated attacks will not increase the chance significantly. In play testing, a ship attacking from a window is typically discovered within three turns.

The most effective search range is determined by the type of astrogation gear employed by the searcher. This table outlines the distance from the target hex that the searcher must be without suffering the range penalty.

The following table outlines miscellaneous or one time factors that can influence the search.

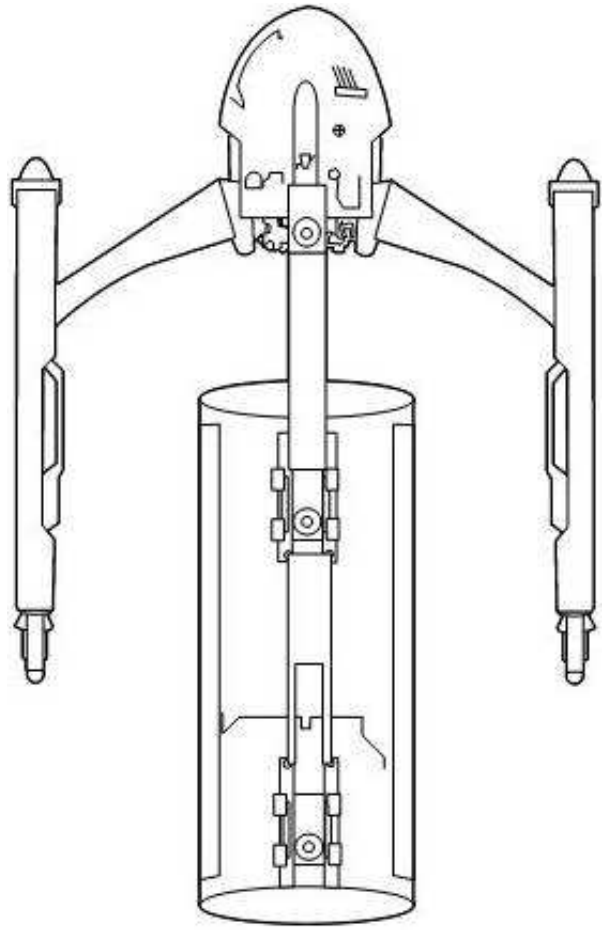

Artwork by Larry Moore

Description	Modifier
Number of windowed hexes above 1	-10 per hex
Number of contiguous turns searching	+1 per turn
Windowed ship was being tracked prior to windowing - 1st turn after windowing	+30
Windowed ship was being tracked prior to windowing - 2nd turn after windowing	+20
Windowed ship was being tracked prior to windowing - 3rd turn after windowing	+10
Windowed ship was being tracked prior to windowing - 4th or more turn after windowing	+0
Windowed ship attacks using rocket weapon other than seeker missiles or mines AND searcher has Energy Sensors- 1st turn after attacking	+30
Windowed ship attacks using rocket weapon other than seeker missiles or mines AND searcher has Energy Sensors - 2nd turn after attacking	+15
Windowed ship attacks using rocket weapon other than seeker missiles or mines AND searcher has Energy Sensors - 3rd or more turns after attacking	+0
Windowed ship attacks using energy weapon AND searcher has Energy Sensors- 1st turn after attacking	+20
Windowed ship attacks using energy weapon AND searcher has Energy Sensors- 2nd turn after attacking	+10
Windowed ship attacks using energy weapon AND searcher has Energy Sensors- 3rd turn after attacking	+0
Searcher has energy sensors AND is within 1 hex of target ship	+5
Per ship in a coordinated search (i.e. searching ships are in un-jammed radio contact - no WNBs active)	+2

**Astrogration Equipment Type\* Effective Range Without Penalty**

Shuttle	Cannot search
System	1
Starship	2
Deluxe Starship	3

\* Range in hexes.

The base chance of finding a windowed ship is 0. Apply the following modifiers to this base.

Range Beyond Effective*	Search Modifier
1	-1
2	-2
3	-4
4	-8
5	-16
6	-32
7	-64
8	-128

\* Range in hexes

**SIDEBAR 2 - NEW EQUIPMENT: DISTRESS BUOY**

Many ion powered ships carry a distress buoy to summon help when attacked. The buoy is simply a type 4 para-battery, videocom radio, and computer that can record the launching ship's location, speed, and direction for automatic broadcast. It is used principally to defeat an attacker's radio jamming, as the distress signal will not begin for a preset period of time. It uses 5 SEU per hour of operation.

There is a deluxe buoy available as well. It adds a solar power array (sub-type 1, 200 SEU per hour) and a very small ion drive (1/4 ADF). This buoy can carry 400 units of hydrogen fuel. It could broadcast indefinitely as long as the solar array is functional.

The mechanically operated launcher is capable of negating up to 5 hexes of the launching ship's speed. The player controlling the launching ship can deploy the buoy at the end of a movement phase up to five hexes behind the ship. The buoy will travel in a straight line at the launching ship's speed minus 1 to 5 hexes. A distress buoy is recoverable if the ship is willing to take the time to do so. The launching ship can send it a coded videocom signal to cancel the distress call as well.

### SIDEBAR 3 - NEW EQUIPMENT: ION DECOY

The canon rules clearly state that decoys can be detected and differentiated from the mother ship by energy sensors, presumably due to a decoy's chemical or atomic drive. So why not outfit one with a tiny ion drive? And while your at it, how about a powerful holographic projector? Now your ion driven ship can launch a decoy (or several decoys) increasing the safety factor of your ion window. All of this for the suggested retail price of 15,000 credits per hull size.



Item	Cost (Cr)
Distress Buoy Launcher	10,000
Basic Distress Buoy	11,000
Deluxe Distress buoy	55,000
Ion Decoy	15,000 x Hull Size

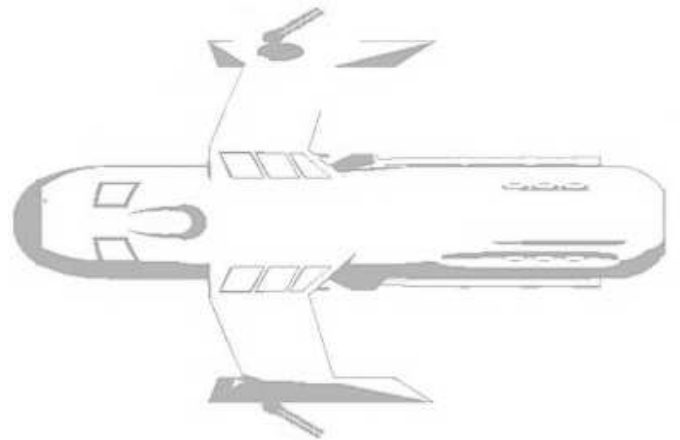

# THE INDUSTRIOUS IFSHNIT

Kimber "Kim" Eastland, Revised by C. J. Williams

**Author's Note:** The original Ifshnit in Zebulon's Guide to Frontier Space, while drawn to look like some kind of "Hollander space gnome" (as many have described them), are actually described as a race covered in long hair from head to foot with larger eyes more closely resembling H. Beam Piper's fuzzies, but with more human-like traits. These were likely introduced to capitalize on the Ewoks of Star Wars. The new image provided for this race in this article is drawn according to the actual description of Ifshnits.

"Pssst! Psssssstt!"

The Yazirian walking through the Minzii marketplace slowed when he heard the hissing and glanced around. He was a dangerous-looking type, possibly one of the newly arrived mercenaries brought in to settle a megacorp dispute on the other side of Bizarre. He located the source of the third "pssst" and stooped down next to the stall selling Grothian crystals.

Standing underneath the crystal-laden table was an Ifshnit, black body hair carefully braided in the manner of a roving Capellan merchant. His tiny stature was emphasized by the gun case he was leaning on; compared to his own diminutive height it looked like a huge suitcase.

"Greeted well, simian warrior." Said the hairy little being in the musical voice common to his race.

The enforcer had no liking for word games but knew Ifshnit customs demanded that the potential customer recognize the merchant as an honorable tradesman. Searching his mind for the correct phrasing, the Yazirian stammered, "Uh, recognized with respect and delight, esteemed shopkeeper. What might you have in the way of special items for a needy enforcer."

The little face grinned, huge eyes glistening with delight. "Oh nothing, surely, that a traveled, experienced personage such as yourself has not seen in his past wanderings. Only some trinkets and unusual weapons."

The last remark was meant to tantalize. It did.

The warrior, feeling a fool for kneeling in the marketplace's dirt street and appearing as if he was talking to a table, began growling with irritation. "Show me anyway, distinguished barterer, that I may broaden my experience."

The Ifshnit waved his ringed hand in the air. "No, no, I could not humiliate myself by revealing to your seasoned eyes my meager wares no matter how rare they may be."

"All right you little pirate," the Yazirian snapped, temper flaring and teeth bared. "I have a few precious

minutes before I bap to another part of your soggy planet. Do you have something to sell or not?"

Though ruffled by the Yazirian's impatience, the Ifshnit felt confident of a sale. Smiling enigmatically, he flipped open the weapon case and turned it toward the monkeyish face. Inside, the strangely shaped weapon gleamed, even in the shade of the table. Its muzzle was still sealed by the manufacturer's stamp, proving the weapon had never been used.

The Yazirian's eyes narrowed. "Is this authentic?" A slight nod from the merchant sent the warrior's eyes back to the beckoning weapon.

Small, jeweled hands snapped open compartments and removed insulating panels. "A WarTech Omega Bolt with tooled krickhide holster. The belt holds six powerclips."

The Yazirian smiled slowly, licking his lips. "I think we can do business, esteemed one."



Artwork by C. J. Williams

**Homeworld:** Ifshna, Capella

**Sample Names:** Alt, Dorim, Meez, Morget, Nister, Orma, Prin, Rindel, Rith, Steth, Tith, Zim.

## PHYSICAL STRUCTURE

Ifshnits are bipedal, symmetrical mammals that look like tiny Humans in hair coats. All Ifshnits have bald pates, moustaches, and long, silky hair over the rest of their bodies. This body hair can be any color but is seldom different shades on the same body. All males have long and ornate beards, usually of a different shade than the rest of the body hair. The body hair of both sexes is usually worn in intricate braids. Each

Each Ifshnit clan braids its hair differently. Ifshnit hands and feet are covered with short hair, except for their palms and soles, which are bare and padded. This short hair is slightly darker than the rest of the body hair. Their hands have three fingers and an opposing thumb, and the feet have four toes.

Ifshnit females have 3 pairs of mammary glands and can birth up to 6 "puplets" at a time. Puplets are born hairless and tiny, but grow very fast and have their long hair within 30 galactic days. They reach their full height by age 9 and full maturity at age 12.

Ifshnit hands and feet are covered with short hair, except for their palms and soles, which are bare and padded. This short hair is slightly darker than the rest of the body hair. Their hands have three fingers and an opposing thumb, the feet have four toes. Because of their small size, Ifshnits cannot use many large items, including normal rifles, without a size penalty.

Ifshnits are herbivores and the thought of eating another creature is utterly revolting to them. Because of their vegetarian diet they are constantly nibbling instead of eating meals.

## SENSES

Ifshnits have normal senses of hearing, touch, and taste. They have almost no sense of smell and have a hard time understanding the concept of scent. Their eyes are masterpieces of biological engineering. A fast-closing nictitating membrane closes instantly if exposed to bright light, preventing the Ifshnit from being blinded. Their night sight is no better than a Human's.

## SPEECH

Ifshnits have a lilting, piping voice that is best described as cute. Their language is intricate, but is compatible with most races' linguistic abilities.

## BRIEF HISTORY

Ifshnits are members of the Rim Coalition, which includes the Humma, Mechanon, and Osakar. The Ifshnits founded the Capellan Free Merchants (CFM) in 51 p.f. as a union of small companies that protects its members from mega-corps and they still control the organization to this day. CFM's primary focus is the sale and distribution of exotic items. These tiny merchants organized hundreds of planet-hopping trading ships plying the spaceways with their wares.

When the Rim Coalition was invaded by the Sathar, the Capellan Free Merchants set out in search for allies.

The CFM ships wandered into the Frontier in 2 p.f. and slowly become an ever greater presence there, even assisting in certain battles against the Sathar.

Earlier, in 3 p.f., the Sathar attacked Pale and New Pale, setting off the first Sathar War on the Frontier. Refugees fled to Laco. However, as Laco was a prime industrial planet with no agricultural production, the survivors soon began to starve. This condition lasted for years with little relief as the Frontier was engulfed in war. Many died.

CFM repeatedly sought permission to assist Laco. But it was not until early in 4 f.y. that the Rim Coalition would be brought to the attention of UPF officials as a valuable ally as it had not been fully ascertained until that time whether they were friendly or not due to the timing of their arrival on the Frontier.

In 4 f.y. the UPF signed a pact between the Rim Coalition and the UPF, allowing CFM to branch into the UPF and immediately take action in behalf of the war refugees on Laco from Pale and New Pale, though the fleet could not arrive until early in 5 f.y. If not for the intervention of CFM, the entire population might have been totally eliminated. As their relief efforts continued, CFM came to the fore of attention in the Core Worlds, hailed as saviors. As a result, the Rim Coalition's own battle with the Sathar soon became a newsworthy concern.

The conditions on Laco led CFM to underwrite a loan to a Yazirian corporation for the formation of the Galactic Overall Development Company (G.O.D.C. or "GOD Co") to perform terraforming.

After the end of the second Sathar War, many Ifshnits remained in the Frontier (Thus it was not until this time that they came to be considered a major race on the Frontier).

In 86 f.y., In gratitude for their help during the rough days following SWI, CFM was granted a UPF charter with special dispensation against the Trans-Travel lobby (the only one of its kind). CFM thus began the Free Merchant trade system throughout the UPF planets. CFM eventually became so firmly entrenched in Frontier life that the Frontier's mega-corps were unable to force them out, and eventually resigned to accept them as another mega-corporation.

## SOCIETY AND CUSTOMS

Ifshnits are the major race in the Capella system and are principally capitalist.

The strange, polite dickering of Ifshnits is known and welcome on most planets. Due to their origins, Ifshnits are fiercely independent. They like neither mega-corps nor cadres. They live in small family clans and are governed by a committee that changes continually.

Ifshnits have a very specific bartering custom that has slowly become common knowledge among the UPF

core worlds. The sale begins with a lavish greeting by the Ifshnit to honor the individual to put them at ease, and then that individual must likewise return the greeting with by recognizing the Ifshnit's integrity as a salesman. They then downplay their wares and then one or more items that they surmise the individual may be interested in. The individual will then express their interest, if any, and the sale can continue.

Any Ifshnit that is found to be of questionable integrity is cast out from Ifshnit society until they have demonstrated a return the Ifshnit trustworthiness. Ifshnits believe that every bad sale and every Ifshnit that demonstrates questionable ethics brings down the trust of the other races toward Ifshnits as a whole.

The primary dogma of Ifshnits is based on the belief that this is the last corporeal existence they will have. Their concept of an afterlife is one of pure thought mixed with gentler emotions. As a part of this belief they tend to ignore the sensual pleasures of life. Their favorite pastimes include games (they love competition), storytelling, and bartering for goods. Ifshnits love gatherings and will find every reason to gather friends and family together to celebrate any occasion, but particularly births, deaths, and large volume sales.

These social conquerors have assimilated well into UPF life, taking part in every aspect of life from street level bartering to administering government affairs; even taking an active role in the UPF military, usually to weed out Sathar spies and protect trade and commerce in the galaxy.

Ifshnits do not typically wear full clothing as they already have hair covering their entire bodies. Instead, they wear open tunics reflecting the fine rare fabrics and exquisite designs typically provided by CFM. They, particularly the women, may also wear exotic accessories and will add beads to their braids.

**ATTITUDES**

Ifshnits are intelligent, brave, patient, and tolerant of other races, and members of most other races like them instantly. However, despite their open, friendly dispositions, Ifshnits prefer being alone or with other members of their clan.

When an Ifshnit demonstrates concern, you can be sure it is genuine, though they will gladly use the occasion to share any of their product that matches the circumstance, but their doing so is an earnest attempt to help. A person is wise to at least give them an ear in their offers, as you never know what wisdom may be expressed in their offer. They take every opportunity to make money to take care of themselves and their family, but never at the expense of the well being of others.

Though they value life more than the other races, they still see the need for repulsing would be usurpers by any means necessary and will come to the aid of CFM

whenever needed, even if it is not their employing company.

They harbor an intense hatred for the Sathar and any who serve them. This is due to their past dealings with the Sathar. Though details are hard to get, apparently the Sathar have plagued the Ifshnits since their history began. This leads many historians to believe that the Ifshnits (or a branch of that race) at one time inhabited Sathar space. Ifshnits have been known to risk life and limb many times over to eliminate Sathar and their agents.

Despite the Vrusk's dispassionate nature, Ifshnits find them interesting for their commitment to their employer as similar to the Ifshnit commitment to CFM. They also love Dralasites for their flexibility, humor, and congenial ways. Humans appreciate Ifshnits for their genuineness and openness, as well as seemingly always having what they need.

**Racial Reaction Modifiers**

Race	By Other	By Ifshnit
<b>Dralasite</b>	+0	+15
<b>Human</b>	+5	+05
<b>Humma</b>	-5	-05
<b>Ifshnit</b>	--	+15
<b>Mechanon</b>	+0	-05
<b>Osakar</b>	+0	+05
<b>Sathar</b>	-10	-40
<b>S'sessu</b>	+0	-40
<b>Vrusk</b>	+0	+05
<b>Yazirian</b>	+5	+10

**MOTIVATIONS FOR ADVENTURE**

Ifshnits are not shy for travelling to exotic worlds to see otherworldly beauty or share their culture, their beliefs, and their goods. They love the stars and seek to bring order to the universe and will sometimes take an active roll in achieving that goal. Ifshnits adapt very well to living and working in space. Dorem Dasak, the famous Dralasite philosopher and historian, has named them "The race of the future, they who will inherit!"

**ABILITIES**

**Flash Resistance:** Ifshnits cannot be blinded by any light, as their nictitating membranes snap shut instantly. They cannot see during the turn a light flashes brightly, but their eyesight will be normal the following turn.

**Innate Skill:** Because of their unique culture, which is heavily based on barter, Ifshnits learn about trading at an early age. An Ifshnit player is allowed to choose one of the following bonuses at no cost when it begins the game: +20% to Appraisal, Gemology, or Haggling.

Ability	Modifier
<b>STR/STA</b>	<b>+5</b>
<b>DEX/RS</b>	<b>+0</b>
<b>INT/LOG</b>	<b>+5</b>
<b>PER/LDR</b>	<b>+0</b>

# PLANETARY BRIEF

Richard "Shadow Shack" Rose

## DIXON'S STAR LACO

**DIAMETER:** 6,625 kilometers

**GRAVITY:** 1.395

**LENGTH OF DAYS:** 59 hours, 52 minutes

**ATMOSPHERE:** 56% nitrogen, 24% oxygen, 1% argon, 16% carbon dioxide

**AVERAGE SURFACE TEMPERATURE:** 70 degrees C (equatorial region), 45 degrees C (Polar Regions)

**CLIMATE RANGE:** arid and dry

**NUMBER OF MOONS:** None

**COLONIZERS:** Predominantly Human

**NATIVE LIFE:** Mostly small reptiles

### PLANET HISTORY

Laco is an outpost world, a pit stop along the Prenglar/Truane's Star travel route. The system itself was discovered by the humans 220 years prior to the formation of the UPF, but the planet was sparsely populated one hundred years afterwards. The planet's axis is perpendicular to its orbit, so the surface receives an equal amount of sunlight year round (and lots of it thanks to a slow rotation). There isn't a resulting seasons, although the polar regions are cooler and nearly hospitable. Aside from the two polar seas, typical landscape is sand and rock, with a mountain range in the equatorial region and several smaller outcroppings of rock dotting the rest of the world. Desert plant life grows abundantly.

Being a rather inhospitable environment, it wasn't an ideal world to settle down on. As such it became a scientific research center and only one major settlement was ever established: Point Glass. Point Glass is not a city, rather a small town of roughly 50,000 inhabitants located along the southern coast, but it does have a starport.

Four smaller settlements are scattered across the surface: Laconia borders the northern shore and boasts a population of 10,000. Dixon's Peak is located in the southern foothills of the Lavaback Mountain range, yet far enough away from its series of active volcanoes and is home to 5000 inhabitants. East of Laconia are a pair of oasis settlements in the sandy regions, Haven being the closer of the two and Castle Station just east of the terminator axis. Both are home to no more than 1000 beings each.

Laco Station orbits the world, a size 3 docking station. A squadron of six fighter craft is stationed at Point Glass as the solitary measure of defense.

### POLITICAL STRUCTURE

Laco is not a governed world, although they are represented at the Council of Worlds. Star Law and several of the more prominent mega-corps have offices in Point Glass as well as in the orbital station. Industry would be considered as the primary economical movement, although the degrees of such production pale in comparison to civilized worlds. The mountain regions host rich deposits of aluminum, iron, magnesium, and tungsten; but barely sufficient to support the minimalist industrial activity and certainly not in sufficient quantities to support a civilized world.



Artwork by Chris Harper

# LACO PLANETARY MAP

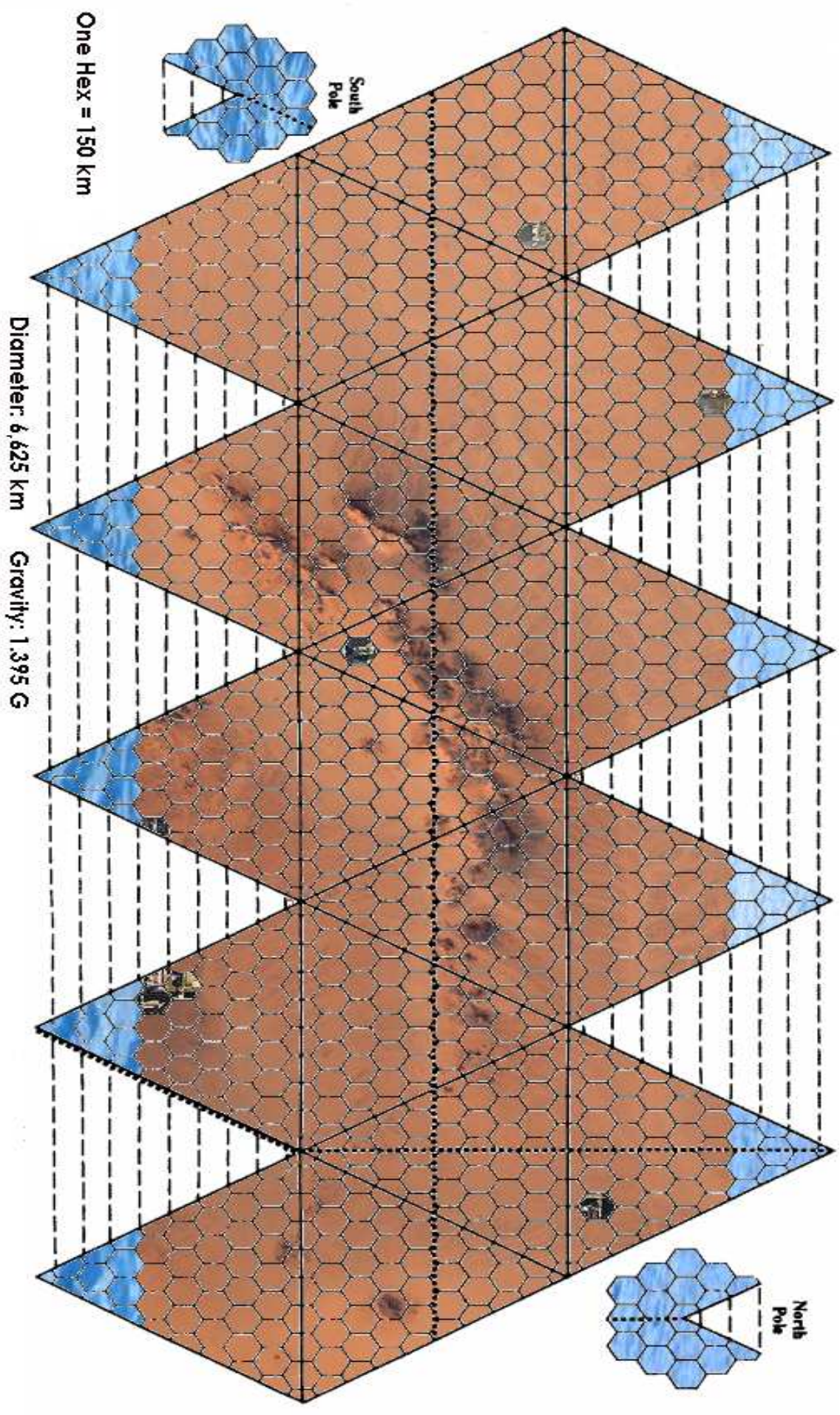



# GROUND & HOVER CYCLE HISTORY

Richard "Shadow Shack" Rose

If you read up on Frontier history, Pan Galactixon is the earliest of the current manufacturers of ground and hover cycles, dating back to before the first Sathar War. Pan Galactic acquired the Galactixon Motor Company when they were going through some financial woes resulting from troublesome quality control and reliability issues stemming from their Duracell-head motor (noted by the copper top on the electric motor cover), a motor that derived from prior generations such as the Eveready-head and Rayovac-head motors. PGC, in essence, saved the Galactixon Motor Company from bankruptcy and they continued to offer Duracell-head powered bikes during the transition.

The inherent beauty of the old Galatixon engines was their simplicity, they were very easy to work on and a proficient technician could perform a full rebuild in a short time, resorting to a healthy variety of both manufacturer and aftermarket parts availability (not to mention the wide array of "canibalized parts", such as the infamous motor coil from the Gord flathead six motor or the brush housings from a Galactic Motors ventral-eight).

As such, PGC footed the R&D funding for the design of their next engine: the GENERation (aka the stockhead), and just before production the 13 company heads of Galactixon purchased the company back from PGC, and thus renamed their products under the new badge of "Pan Galactixon". The PGC era bikes had a mixed review, the older riders resent the newer product blaming PGC for ruining the designs while the newer riders talk smack about the older designs, but the truth is that the Galactixon Motor Company products were faulty before PGC acquired them.

Anyways, the GENERation motor proved to be a gamble that the 13 investor/owners didn't mind rolling the dice for. The motor ended up being everything it had been promised to be: a reliable engine based on the original timeless design. Their latest engine is the TG-880B (aka the Twin Generator aka the "twinjee") and has replaced the GENERation across the entire line-up.

Meanwhile, during the PGC transition there were some serious competitors from four distinct Streeel-sibling companies that challenged Galactic Motor Company during all three phases of their business tenure. Marks like Hyondow, Kyawaskai, Sushuzi, and Yamihai were belting out some high performance low cost machines that proved themselves both on the track and on the roads. They sported newer technology and laserblast-proof reliability, and when Streeel sensed that the Galactic Motor Company was in trouble they pulled a fast one and began dumping their products into the market at below-wholesale pricing. This illegal trade

practice was quickly noticed by both the local economist leaders and the legal team of Galactic Motor Company, hence it was brought before the Council of Worlds and it was decided that a tariff would be placed on all ground and hover cycles produced under the various Streeel marks.

Several subsidiaries of Cassidine Development Corporation entered and left the market during the GMC/Streeel competition era. Manufacturers like CSA, Dorton, and Triamf began to lose ground to Streeel's screamers, and only Triamf survived (barely at that). And other marks like Buckerton Motor Works (of Kdikit) and Danati (named after Pale's moon) silently soldiered on while providing their niche market products.

The modern ground and hover cycle market is thriving and competition is fierce. Pan Galatixon continues to duke it out with Hyondow for top market share each year, while Kyawaskai, Sushuzi, & Yamihai consistently slug it out for third place. Triamf is belting out some incredible products for all the niche markets, and Buckerton Motor Works continues to offer luxury comfort and decent performance. Danati is still the leader in handling despite the breakthroughs from Streeel's subordinates, but they are fully aware of this and continue to pour funding into superior suspension and braking technology, with their most recent (and most expensive) 999 model leading the way. And finally, Herik Fuell (former design engineer and current subsidiary of Pan Galatixon) has challenged Danati by offering some street sensible alternatives.

All in all, for anyone wishing to plant their knees in the breeze, the time is ripe with the wide variety of great product out there.

Put that tin in the wind, SS.

**Slick, sick, and anything but plain.  
Get it done somewhere else and  
you can take the blame!**



**CHOPPIN' AWAY AT PORT LAVAKOS, VOLTURNUS (ZEBULON)**

# NEW EQUIPMENT

Chris Harper

**Authors Note:** I have always been intrigued by the picture of the Yazirian holding that big triple barreled gun on the cover of the Star Frontiers Basic Rules book. I'm sure it is just the artist's idea; as there are no specific rules or descriptions for such a gun.

I think the gun looks cool and deserves to finally be used in the game. Here is my idea of how the gun came to be.

## YAZIRIAN TRIPLE BARREL GYROJET HISTORY

During the Second Sathar war The Yazirian space commandos of Yast wanted a squad support weapon. They primarily used gyrojet rifles at the time and wanted a gun that could deal out more damage and still use similar parts and ammo as the standard issue rifles, and also function in the vacuum of space. Zik Kit ordinance was commissioned to design the weapons. Their solution was the Triple barreled gyrojet rifle.

The primary tactic of the triple barreled gyrojet rifle is to use the explosive rounds to punch multiple holes simultaneously in spacesuit armor. This would either cause the autoseal on the suit to fail or the being inside the suit could not patch all the holes in time. This would cause fatal decompression; feared by all who have used a space suit.

The Triple barrel gyrojet rifle can also inflict heavy structural damage. Space commandos would use the guns to damage vital materiel or gain access through a destroyed hatch, on a disabled ship. Many believe that this tactic prompted Sathar to self destruct their ships.

The rifles were used with great effect against the "Slugs" in space combat. The gun could rip several fatal holes at one time in space suit armor. More often it would blast a triangular hole in the suit armor. Earning the gun nicknames, "Opener" or "Ripper". This was a good moral booster to any squad wielding one. Not to mention the psychological affect on the enemy. The had a reputation for being very reliable.

## OPERATION

Simply three gyrojet rifles modified to be in a triangular pattern. Each receiver and barrel has its own 10 round clip. Similar in parts and operation to a common gyrojet rifle. It uses the same clips and ammo as a standard gyrojet rifle. The difference is that the rifle has a selector that allows one or three gyro stabilized rockets to be fired at one time.



Artwork by Chris Harper

The back section of the rifle is a recoil damper. The damper is needed because of the high amount of recoil that firing three rounds produces. It also counters the effects of reaction movement while in zero gravity. A character using one does not have to make a RS check (per weightless combat rules in SF Expanded Rules) The damper uses a small inertia field to counteract the shock. The damper uses a standard 20 SEU power clip to operate. The clip must be replaced every 100 shots. If the rifle is used without the damper operating; the character will receive 1d10 / 2 damage each shot.

When firing single shots the rifle will cycle through to the next fullest clip to fire. This reduces the chance of having an uneven amount of bullets in the clips. The Tri- barrel takes two turns to reload all clips.

When firing a burst of three rounds and a jamb is rolled on a 96-00 only one barrel has jammed and the other two will still fire.

The close proximity of the rounds when they impact produces a collective explosion that can cause massive structural damage. When all three barrels are fired at a door, wall, vehicles etc., 30 points of structural damage is inflicted.

The gun is heavy and bulky so there is a -2 to initiative modifier for the rifleman (only when used in gravity). On a burst of 3 the rifleman receives a +10% to hit. (This is instead of the normal +20 for a 10 shot burst, as it creates a much smaller pattern.)

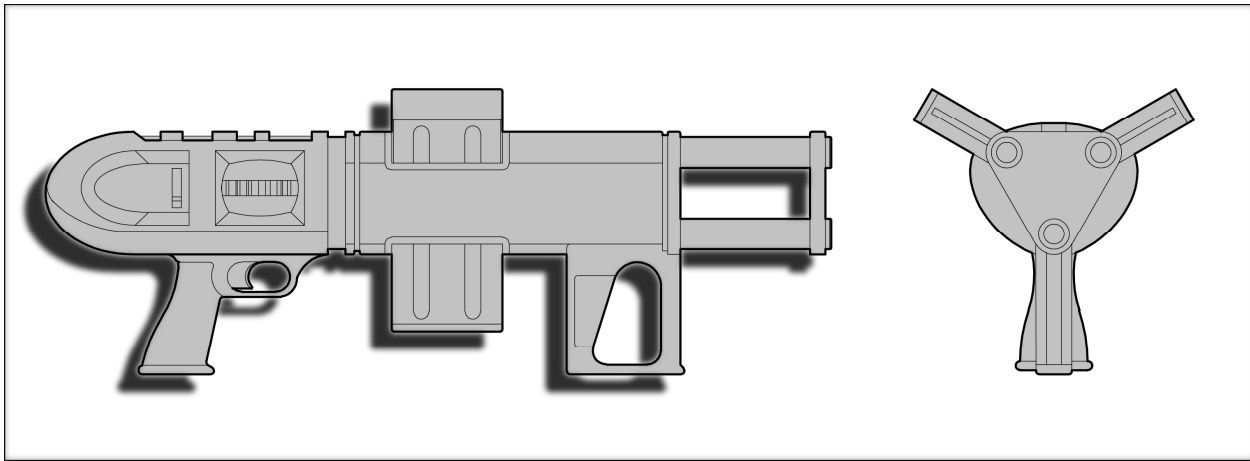

Artwork by Chris Harper

### Yazirian Triple Barrel Gyrojet

<b>Type</b>	Gyrojet Semi-auto, Clip fed
<b>Cost</b>	800Cr, Ammo 20 Cr per 10 shot clip
<b>Length</b>	.83 meters
<b>Weight</b>	11kg
<b>Damage</b>	Single: 3d10 Burst: 9d10
<b>Ammo*</b>	30 (3 clips of 10)
<b>Defense</b>	Inertia
<b>Range</b>	-/5/75/150/300
<b>Skill</b>	Gyrojet

\* The Recoil damper require a 20 SEU clip every 100 shots.



### Character Background Library Reference;

**ssr://gw.gollywog.library.gov/wartech**

You owe your life to the pirates. At least that's what you have been told. Years ago your settlement became the focal point of a corp-war. Unfortunately your home came under friendly fire leaving your parents and brother dead. The pirates have taught you everything you know. A skilled fighter pilot and deadly with a Yazirian gyrojet pistol your skills are complete to become "one of them". Just before your official inauguration a message arrives in a private mail box located on your home planet. It's your brother and he is alive! More importantly you discover you were not "saved" by the pirates. The pirates.....

### Other Notable Gyrojet's

#### WarTech GC-6 Gyrojet Carbine

**Cost:** 250Cr, **Wgt:** 3.5kg, **Damage:** 2d10, **Ammo:** pistol jetclip 5, **Rate:** 3, **Defense:** Inertia, **Range:** -/5/50/75/125

**Description:** Small, compact easy to use personal weapon. Designed for use by back-line troops or issued when weapon size is a problem.

#### WarTech GAR-10 Gyrojet Assault Rifle

**Cost:** 400Cr, **Wgt:** 5.5kg, **Damage:** 3d10/8d10, **Ammo:** 20 rounds, **Rate:** 3(1), **Defense:** Inertia, **Range:** -/5/75/150/300

**Description:** Standard gyrojet rifle with extended magazine and burst fire capability (uses 5 gyrojets).  
**Notes:** Rifle Jetclips for the GAR-10 cost 40Cr, for 20 rounds.

#### WarTech HGR-9 Heavy Gyrojet Rifle

**Cost:** 2,000Cr, **Wgt:** 12kg, **Damage:** 10d10, **Ammo:** 5 rounds, **Rate:** 1, **Defense:** Inertia, **Range:** -/5/60/125/200

**Description:** Heavy gyrojet rifle. Designed for light anti-vehicle or anti-material role.  
**Notes:** HGR Jetclips cost 50Cr for 5 rounds.

#### WarTech GJMG-12 Gyrojet Machine Gun

**Cost:** 7,000Cr, **Wgt:** 25, **Damage:** 15d10, **Ammo:** 5 bursts, **Rate:** 1, **Defense:** Inertia, **Range:** -/5/75/150/300

**Description:** Designed for heavy fire suppression and anti-vehicle work. This heavy weapon must be mounted on a tripod. **Notes:** Ammo cassette of 5 bursts cost 100Cr.

#### WarTech PGR-2 Precision Marksman Gyrojet Rifle

**Cost:** 1,500Cr, **Wgt:** 5.5kg **Damage:** 3d10, **Ammo:** 5, **Rate:** 1, **Defense:** Inertia, **Range:** -/70/200/500/1km

**Description:** Extreme long range Gyrojet for precision sniper work. **Notes:** 5 round Jetclip for PGR costs 40Cr.

# THE CORE FOUR-PART I

Brian Conway

**Editor's Note:** In future issues Brain will be submitting Vrusk, Yazirian and an article on the Sathar! We look forward to them!

## DRALASITES

**Alpha Dawn:** Dralasites are short, rubbery aliens that have no bones or hard body parts. Their skin is a flexible membrane that is very tough and scratchy. It generally is dull gray and lined with dark veins that meet at the Dralasite's two eyespots.

One thing I would like to add is that the Dralasites are actually as pliable in their society as they are with their membranes. These are folks that embrace change and outside ideas better than any other race in the Frontier. After all, it is completely natural for a Dralasite to question authority, if only for the sake of an entertaining (preferably humorous) debate. Therefore, through these interminable discussions, many new ideas are uncovered and implemented as the stoa discusses the matter over a nice hot steam bath. Sometimes psychedelic perfumes are added to these batches to provide some additional "perspective".

"Laughter is food" is the mantra of all Dralasites. Comedians - human or otherwise - are among the most respected and honored members of the community. Comedians are expected to "be funny" at the drop of a hat, and this skill is highly prized (and compensated).

Jokes and funny stories are the meat and drink of Dralasite interaction. Vrusk businessmen are particularly poorly equipped for this - often the deal will go to the proposal whose presenter told the funniest story or put amusing shapes and designs into the proposal book. This lack of business fundamentals infuriates the number-crunching Vrusk and leads to massive frustration when a Dralasite is the ultimate decision maker. Dralasites want to do business with someone who has personality!

Dralasites make friends pretty easily. They can be good listeners and have a natural gift for diplomacy, tact, and generally try to avoid conflict and have some laughs during work. Most are quite outgoing, and have no qualms about introducing themselves and getting the social ball rolling.

Dralasites make excellent "Devil's Advocates" and while this can be annoying at times, it is extremely valuable during business, legal, or military situations. You can count on a Dralasite to ask questions and make

comments when someone says the obligatory "Any questions?" at the end of a meeting.

All Dralasite politicians are consummate debaters. Those that reach senior positions in government are formidable debaters indeed and have regularly embarrassed their Human, Yazirian and Vrusk counterparts during electoral debates. However, their unusual shape and ways gives them a disadvantage in the way of charisma. Dralasites look a lot alike, so their politicians have to win elections with what they say, not what they look like when they say it. Slick human politicians have been able to beat Dralasites even after being totally schooled during debates due to this "charisma factor".



Artwork by Shell

### Some Dralasite quirks:

Dralasites love to make other races laugh, and consider that a great achievement - especially a sour puss Yazirian! They enjoy contorting their bodies into humorous shapes for this purpose. Dralasites are very popular with children of all the Races because of this.

Dralasites are famous for their circus-like strong men. They do all kinds of wild feats of strength which wow audiences all over the Frontier.

Dralasites are the least violent of all Frontier races. They also have had the fewest numbers of wars in their long history.

Stoa may exile members but often let them atone and come back. Jokes, tall tales, and healthy debate goes a long, long way to bringing an exile back into full status with the community, unless the crime was particularly heinous (i.e. violent).

Dralasites are very fond of soups, puddings, sauces, gravies, and all other liquids and near liquid foods.

Dralasite cuisine is one of the few where all of the other races can at least get by and have something decent to eat. Vrusk love to eat bugs, Yazirians prefer their food to be meat (and raw - preferably still alive!) and humans with their cooking grosses out the Vrusk and Yazirians in general. Many members of the other races even go out of their way to pack some Drammune Pudding in their lunch boxes! No other cuisine enjoys such a wide following around the Frontier as Dralosite.

At this point in Frontier history, the Dralasites have more than earned their place among the leaders of the Frontier in every category. Even the proudest old Yazirian or the most buttoned-down Vrusk has been known to crack a smile at the antics of the Dralosite, not to mention be swayed by their cogent thought and debate.

**Chris Harper** made a custom Agriculture ship to use with the Knight Hawks tactile board game.

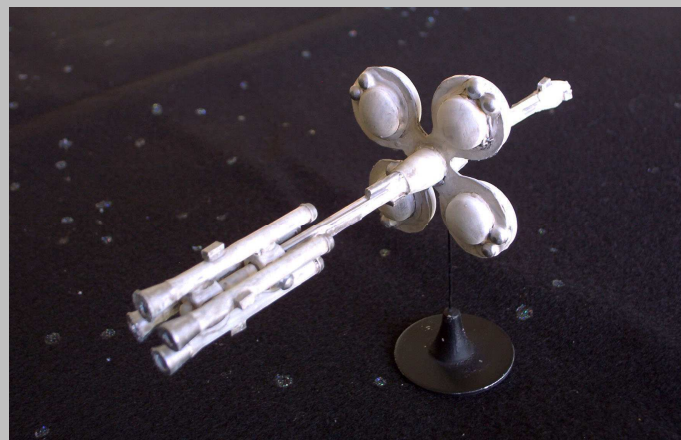
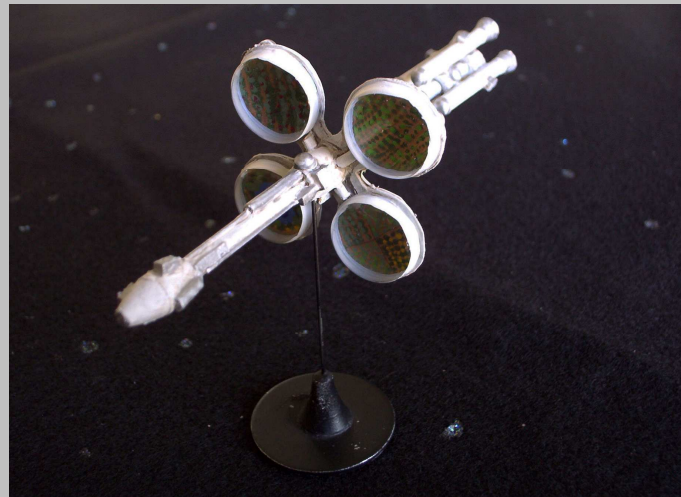

The Agriculture ship next to a UPF Battleship and Cruiser.



**Details:**

<http://starfrontiers.us/node/3607>

# HUMANS

My take on the Humans is that they are just like us, only several centuries into the future.

Advanced medicines and gene therapy developed longer lives and a world effort to get off of the planet was launched. Trillions of dollars (credits?) of research, industrial development and robot assistance.

A key leap forward in Human space exploration was the construction of cheap, safe rocketry through a crude ion engine. Eventually, the space station turned into a zero gravity shipyard. With advances in space suit technologies, combined with new NanoProcessors, mankind began to manipulate space itself to facilitate spaceship construction.

Meanwhile, better and better probes fanned out. Each one faster, seeing farther, poking deep into the Cosmos. Fortunately, habitable planets were eventually discovered in the millions of probe scans.

It was time for the Human Race to breathe at last!

Zero-gravity launches made for great increases in speed and efficiency. Finally mastering the Void is a story told better somewhere else. But it happened, and here they are, spread amongst a couple of worlds.

Think about how diverse we are here on Earth and you have an idea of what Star Frontiers humans are like. The whole rainbow of nations, language and culture is still among the Humans.

Humans mainly fall into two large personality types - specialists and generalists. No one admits that they are this way, but most sociologists theorize along these lines.

Some humans prefer to master a particular skill. It constantly amazes the other Three Races that frequently you will have a genius human running a faculty of Yazirian scientists at any local Galactic University!

These specialists do Humanity proud with their tenacity and skill, but unfortunately they don't know too much more than their chosen endeavor (passion). As a result, most of the specialist folks are rather, ahem, ignorant of many Frontier goings on. Politics really does not interest them at all, and they are often swayed by charismatic demagogues if they get riled up over some emotional issue.

Specialist humans prefer human worlds. Some of them go outside because they have to. They will normally visit the other worlds and complain a lot and miss home. They can't wait to go home and go to the game and drink beer. Some hack it better than others, but most specialist humans will take their vacations on their homeworld, if not home town. Many dream of

transfers back home by the UPF or corp that they work for.

Generalist humans have a more wide/open minded approach. They are awed by the majesty and mystery of the other Races and the areas of the Known Galaxy. Some of them manage to excel as much as the specialists do, but make sure that they remain keenly aware as to what is going on with the Federation Government. Most also have a keener knowledge of art, history, culture and the other Races. Generalists "work to live". Specialists "live to work".

Most generalist humans are fascinated by the other Races and curious about other worlds. They do their best to adjust to racial norms and quirks - but hey - talking to some guy who looks like a huge bug who is breathing out of his ass would freak all humans out! So the inevitable faux pas occur, especially with the Vrusk.

Some humans just can't get over the Vrusk form. Many humans don't like bugs or anything that looks like a bug. Sad, but true. Add that to the fact that the Vrusk are cunning, ruthless, almost-mind-reading businessmen, and discomfort and suspicion of the Vrusk is commonplace. Some Humans admire the Vrusk and vice versa, but in most cases the attitude is mutual disdain.

Dralasites and Humans get along very well. Dralasites know that Humans are freaked out by their appearance (Dralasites think this is funny), and try to make jokes and contort their bodies in wacky ways to amuse humans when they first meet them. Human children love when Dralasite friends come over as they will contort their bodies into the craziest shapes while continuing their conversations with the adult Humans! This serves as a great ice-breaker, and after that the Human is usually more than comfortable with Dralasites. Humans love to laugh too, and some actually are VERY amused by the slapstick comedy that the Dralasites love to perpetrate. Good natured practical joking and betting contests on mundane things and events are other ways that Dralasites and Humans connect. Vrusk shake their heads and wonder if "these people ever get any work done around here." Yazirians frown and threaten to beat the crap out of anyone who plays a practical joke on them.

Dralasites and Humans are probably the closest two Races in the Frontier. There is probably not a single Human in the entire galaxy who has met a Dralasite and not had a good laugh AT LEAST once. Dralasites have long fuses and are not easily insulted, yet they are very polite and sensitive to others. Humans greatly appreciate this and admire the Dralasite's ability to contort their personality just like they contort their bodies - based on the local/social circumstances of the moment. Dralasites are very good listeners, and many Humans are very good talkers.



Artwork by Shell

Humans and Yazirians can also form very strong bonds. More serious humans such as military men enjoy Yazirian company. Yazirian Battle Rage is a wild sight for a human. They respect and admire the warrior ethos just under the skin of every Yazirian.

However, many Humans find Yazirian concepts of "honor" very perplexing. Not touching a Yazirian unless in their Clan is also odd to Humans, who often kiss, hug, or shake hands as a greeting. Yazirians will often get insulted over the slightest faux pas and storm out of the room/party/event in a huff. Often the Human will have to then profusely apologize, usually offer some alcohol or other intoxicant, which the Yazirian then consumes. At this point the Yazirian usually tells the Human what a great guy he is, that he overreacted, etc. etc. and then everything is cool. Quite the emotional roller-coaster.

Humans and Yazirians will often get into nasty brawls and fights with each other, especially when alcohol is involved. Ugly Race-based violence does take place from time to time between Yazirian and Human, though more in a swarming mob way than anything acutally organized.

Clan membership, of course, makes up for all of that. Humans are the most often invited race into Yazirian Clans. Some Humans enjoy the experience so much that they live among the Yazirians for the rest of their lives. Most Humans like to party, at least on some level - plus a Yazirian would probably not invite a Human that did not party into their Clan in the first place! A few humans have abused their Clan privileges, but the

thing that reassures all is that many of them were caught/stopped by other, loyal Human members of the Clan.

Very powerful, very famous, and very esteemed Humans are sometimes members of multiple Clans. Fleet Admiral Morgaine, for instance, was a member of 16 Clans! Such honors are reserved for Humans that awe the Yazirians. These kinds of Humans get all of the benefits, but not any of the burdens of multiple Clan membership. However, most Clans will avoid admitting members of Clan rivals into their midst, unless it is someone like Morgaine. In that case it is done as a symbol of Yazirian unity and fellowship with Humanity.

Humans admire Yazirian courage. Yazirians admire Human bravado. There is no better place where Humans and Yazirians get along than on the battlefield. A very common reason for a Clan invitation to a Human is because of the Human saving the Yazirian's life in battle, or sharing the glorious nectar of a huge military victory.

More than any other Race, Humans live among the other races. Human Clan members thrive on the Yazirian worlds (as long as they get to cook the meat!) Even non-member Humans can get by reasonably well on the Yazirian worlds. Many Humans live among Dralasites as well, as their stoa are among the safest communities in the galaxy. "Going off to the Dralasites" is a common phrase meaning retirement. Even among the Vrusk the business seminar entrepreneurs and their supporting industries and other businessmen can strike a home. Humans also form large percentages of the population on the mixed race planets. By contrast, relatively few of the other races live on Human worlds.

One thing that Humans seem to possess more than the other races is the thing that gets them into the most trouble - Charisma. For some strange reason, Human politicians and speakers, more than anyone else, seem to connect with all Races better than politicians with the other Races. Not that the Humans always win elections, etc., but Humans are very adroit politicians. Vrusk particularly will underestimate Human politicians and businessmen, often with disastrous results for the Vrusk scheme. Human politicians get the support of the other races easier than any of the other races do. As a result, many of the mixed Race planets' leaders are Human. Many studies have been done to figure this out, but there are only theories at this point.

"Something about those Humans..." is what the other Races say. Humans are the most, best and worst all at the same time. They can be bigger clowns than Dralasites, bigger bean-counters than Vrusk, more proud and courageous than Yazirians.

They may not be dominant, but Humans are at least strongly represented in every worthwhile endeavor in the Known Galaxy.

# CHARACTERS-R-US

Larry Moore

Curious about the Characters submitted on the StarFrontiers.us site I decided to put together a list and present it here. They are great for NPC's or fill-in characters during a gaming session. I've also listed all the races that have been submitted to this webzine.

Here is the breakdown of the 86 characters submitted listing them by PSA, Gender and Race.

PSA	Number of Characters
Military	47
Technological	24
Biosocial	15
<b>Total</b>	<b>86</b>

Gender	Human	Vrusk	Yazirian	Total
Female	6	2	3	10
Male	37	7	19	64
Dralasite	--	--	--	12

Race	Number of Characters
Vrusk	9
Dralasite	12
Yazirian	22
Human	43
<b>Total</b>	<b>86</b>

PSA by Race	Total
<b>Vrusk</b>	<b>9</b>
Military	4
Technological	3
Biosocial	2
<b>Dralasite</b>	<b>12</b>
Military	6
Technological	5
Biosocial	1
<b>Yazirian</b>	<b>22</b>
Military	13
Technological	3
Biosocial	6
<b>Human</b>	<b>43</b>
Military	24
Technological	13
Biosocial	6

The following table list races submitted to the **Star Frontiersman** including races from the *Alternity RPG* and *Alpha Dawn's Volturnus* series!

## Star Frontiersman Submitted Races

**Aleerin**  
#7, p-3



**Nagana**  
#1, p-10



**Arborean**  
#6, p-19



**Robot PC's**  
#6, p-1



**Boon'sheh**  
#3, p-30



**Scree**  
#9, p-11



**Bora-Kai**  
#2, p-20



**Sesheyan**  
#7, p-7

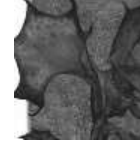

**Eorna**  
#8, p-19



**T'sa**  
#7, p-9



**Fraal**  
#7, p-5



**Ui-Mor**  
#5, p-4



**Gorlian**  
#8, p-55



**Vimh**  
#5, p-35



**Kurabanda**  
#7, p-17



**Weren**  
#7, p-11



**Mechanon**  
#8, p-62



**Yinni**  
#4, p-33





## Star Frontiers Submitted Characters

<http://starfrontiers.us/character>

Name	Species	Gender	STR/STA	DEX/RS	INT/LOG	PER/LDR	PSA
<b>Malic "the Malthar" Tharigan</b>	Dralasite	N/A	60/80	40/50	70/90	60/60	Biosocial
<b>(Mistress) Tara N. Chaynes</b>	Human	Female	55/50	45/45	50/50	75/65	Biosocial
<b>"Siggy" Murtleford</b>	Human	Male	65/65	55/50	35/35	65/65	Biosocial
<b>Adita "Angel" Rosa</b>	Human	Male	70/70	50/50	55/50	60/50	Biosocial
<b>Johann Schmidt</b>	Human	Male	45/45	55/55	68/68	35/35	Biosocial
<b>Rae-Van</b>	Human	Male	41/49	64/51	65/45	45/55	Biosocial
<b>Ralic "Doc" Shodohas</b>	Human	Male	65/65	65/65	50/50	65/65	Biosocial
<b>Ch'k L't</b>	Vrusk	Male	50/50	40/40	45/45	65/55	Biosocial
<b>Streel K'liKit</b>	Vrusk	Male	50/60	50/50	65/65	70/70	Biosocial
<b>Roma Sahai</b>	Yazirian	Female	40/50	70/70	60/60	70/70	Biosocial
<b>Yezha</b>	Yazirian	Female	35/45	45/45	55/55	60/60	Biosocial
<b>Billow</b>	Yazirian	Male	45/45	55/55	60/60	45/45	Biosocial
<b>Eusyl</b>	Yazirian	Male	35/35	45/45	75/75	50/50	Biosocial
<b>Jareb Longfellow</b>	Yazirian	Male	55/55	70/70	60/60	55/55	Biosocial
<b>Terl Obar</b>	Yazirian	Male	60/60	60/60	45/45	40/40	Biosocial
<b>Dahara Koranson</b>	Dralasite	N/A	45/45	55/55	45/45	70/70	Military
<b>Gumbahr</b>	Dralasite	N/A	75/75	45/45	50/50	35/45	Military
<b>Jak "Jokhi" Rapier</b>	Dralasite	N/A	70/70	60/50	45/55	55/55	Military
<b>Jim Arborgahst</b>	Dralasite	N/A	75/75	50/50	50/50	30/30	Military
<b>Sahn Drazl</b>	Dralasite	N/A	50/40	35/35	40/30	50/30	Military
<b>Sporkul</b>	Dralasite	N/A	65/65	50/50	45/45	40/40	Military
<b>Alissa Quinn</b>	Human	Female	50/50	60/60	75/70	65/65	Military
<b>Hannah Creed</b>	Human	Female	45/45	60/60	75/70	55/55	Military
<b>Admiral Gergmaster</b>	Human	Male	45/45	55/55	70/70	40/40	Military
<b>Allan Thibideau</b>	Human	Male	60/60	40/40	70/70	65/65	Military
<b>Benster DeVoulge</b>	Human	Male	50/55	70/50	50/40	45/35	Military
<b>Brutus Stoutlin</b>	Human	Male	70/70	65/65	35/35	45/45	Military
<b>Danyon Fenn</b>	Human	Male	50/50	67/67	50/50	55/55	Military
<b>Dargan</b>	Human	Male	45/65	60/56	45/45	40/60	Military
<b>Dominic Haigh</b>	Human	Male	65/65	55/55	55/55	55/35	Military
<b>Drialick</b>	Human	Male	65/65	55/60	60/60	50/50	Military
<b>Eric "the Mouse" Stromm</b>	Human	Male	65/70	60/50	45/45	35/35	Military
<b>General SsFar</b>	Human	Male	30/30	70/70	90/90	60/60	Military
<b>Guenther Smith</b>	Human	Male	44/56	64/61	50/40	45/45	Military
<b>Jack "Shotgun" Walker</b>	Human	Male	65/70	60/60	50/50	45/45	Military
<b>Jahred Connel</b>	Human	Male	50/50	60/60	60/60	45/50	Military
<b>Jon Smith</b>	Human	Male	60/60	30/30	45/45	65/65	Military
<b>Matt Watson</b>	Human	Male	60/60	50/50	70/70	50/50	Military
<b>Olasnah Felkin</b>	Human	Male	45/60	60/50	50/50	45/45	Military
<b>Robert "Razor" Kitridger</b>	Human	Male	50/60	60/50	50/50	45/55	Military
<b>Simon Wesley</b>	Human	Male	50/50	40/40	45/45	50/45	Military
<b>Slade Lockjaw</b>	Human	Male	48/48	65/65	50/50	40/40	Military
<b>Tomm Gunn</b>	Human	Male	70/75	50/50	45/45	55/55	Military
<b>Zachariah Slade</b>	Human	Male	55/55	75/70	60/60	50/50	Military
<b>Zagon Fash</b>	Human	Male	65/65	60/50	40/40	45/45	Military
<b>Ch' tyX</b>	Vrusk	Male	30/30	70/70	60/60	50/50	Military
<b>Dosärmas</b>	Vrusk	Male	55/65	70/70	45/45	35/35	Military
<b>K'ras-Tvil</b>	Vrusk	Male	65/65	65/65	45/45	30/30	Military
<b>K'wik Z'wik</b>	Vrusk	Male	35/35	70/75	60/60	40/40	Military
<b>Jeticia Nye</b>	Yazirian	Female	40/50	65/65	45/45	50/40	Military
<b>Alik Klar</b>	Yazirian	Male	45/55	65/55	50/50	45/45	Military
<b>Gideon Pai-jon</b>	Yazirian	Male	50/60	70/60	55/55	40/50	Military
<b>Gok Hargut</b>	Yazirian	Male	50/60	75/55	35/55	45/45	Military
<b>Grelikk</b>	Yazirian	Male	45/45	75/75	40/40	45/45	Military
<b>Gret Korg</b>	Yazirian	Male	40/40	70/70	75/75	55/55	Military
<b>Grobber "Ice" Jaloub</b>	Yazirian	Male	40/50	65/65	50/50	45/45	Military
<b>Khan-gha</b>	Yazirian	Male	120/120	50/50	45/45	45/45	Military
<b>Ri-kono "Riki" Shea-Dow</b>	Yazirian	Male	45/55	65/55	45/45	35/45	Military
<b>Sho-Pi Dala</b>	Yazirian	Male	55/55	50/50	50/50	70/70	Military
<b>Sketch</b>	Yazirian	Male	35/35	70/70	60/60	50/50	Military
<b>Terc Krenn</b>	Yazirian	Male	60/60	60/50	40/40	45/45	Military
<b>Xodia (Joshua's Character)</b>	Yazirian	Male	40/40	45/45	55/55	40/40	Military

Name	Species	Gender	STR/STA	DEX/RS	INT/LOG	PER/LDR	PSA
Alfrood "Al" Lannin	Dralasite	N/A	65/65	55/55	50/50	60/60	Technological
Drupal	Dralasite	N/A	35/35	35/35	40/40	45/45	Technological
Gloob	Dralasite	N/A	60/60	60/60	65/65	45/45	Technological
Gluck	Dralasite	N/A	45/45	45/45	50/50	45/45	Technological
Norel-Kho Speetrazier	Dralasite	N/A	50/50	45/45	55/45	65/65	Technological
Gillian Trivette	Human	Female	50/50	70/70	70/70	60/60	Technological
Rhanda Klast	Human	Female	65/60	50/40	50/60	60/50	Technological
Belinda "Big Bertha" Bertholini	Human	Female	75/75	60/50	45/45	35/35	Technological
Charles Babbage	Human	Male	70/70	50/50	70/70	60/60	Technological
Doral Lampkin	Human	Male	65/65	45/45	70/70	60/60	Technological
Ernest Rook	Human	Male	60/60	65/65	65/65	50/50	Technological
Ivan "The Mouse" Vasilev new	Human	Male	45/45	45/45	50/50	65/60	Technological
John Knightrazor II	Human	Male	50/60	65/65	75/65	55/70	Technological
Johnathan Densi	Human	Male	50/50	65/60	50/50	70/70	Technological
Jonathan Streele III (pf:100)	Human	Male	45/55	45/45	70/70	50/70	Technological
Lucifer "Star Devil" Yurak (pf:100)	Human	Male	60(90)/70	60/60	60/70	40/60	Technological
Sebastian Bach Rogers	Human	Male	60/60	60/55	45/45	35/35	Technological
Steven "Rex" Knightrazor	Human	Male	65/75	75/65	95/95	80/90	Technological
Velon	Vrusk	Female	45/55	60/60	55/55	45/45	Technological
Vroo-Stilla	Vrusk	Female	60/60	75/75	60/60	50/50	Technological
Tichat-ka	Vrusk	Male	45/45	65/65	48/48	50/50	Technological
"Rinny" Rin-Blanka	Yazirian	Male	45/55	65/55	65/75	55/55	Technological
w00t	Yazirian	Male	45/55	50/50	60/70	50/60	Technological
Zinthos	Yazirian	Male	35/35	70/70	40/60	45/45	Technological

\* The above table is ordered by PSA then by Species.

Starting characters begin play with two skills, each at first level. One of these skills *must come* from the PSA, but the second one can be any skill at all.

**Military Skills**

Beam Weapons, Demolitions, Gyrojet Weapons, Martial Arts, Melee Weapons, Projectile Weapons, Thrown Weapons

**Biosocial Skills**

Environmental, Medical, Psychosocial

**Technological Skills**

Computers, Robotics, Technician



Artwork by AtomicKnight (3)

**Gernak's Ship Design**

We specialize in "thought to design"  
\* Medical Insurance Required.  
 Chronocom Subspace Relay#  
**820143083747752251891**

# INSPIRATION ZONE

Sam Quier

## A SATHAR ADVENTURE

While prospecting in and around an outer system gas giant, a mining crew discovers a derelict vessel within a gas giant's L4 point. The derelict has the better part of an asteroid sticking out of its hull. Asteroid fragments litter the area with several of them orbiting close to the hull spinning in different directions reminiscent of the Yazirian One dance. The ship appears to be of Sathar construction. Upon further inspection the crew confirms it's definitely Sathar and judging by the derelict's engine design, it dates back to the First Sathar War! Eager to discover the derelict's secrets and ignoring standard protocol, the mining crew locks onto the asteroid and conducts an EVA to reach the ruptured hull.

## PLOT TWIST

### WAKE UP!

When the Sathar ship was struck by the asteroid, the ship went to automatic hibernation mode activating a stealth field blocking all outbound communications. The mining crew that went aboard and entered a hibernation chamber by accident. They are safe but in suspended animation. When help arrives they will find the crew safe and sound (along with the Sathar crew!!) but there are red lights blinking in every hall. All computer terminals show the same message.

SELF DESTRUCT IN 3:24

SELF DESTRUCT IN 00:23:24

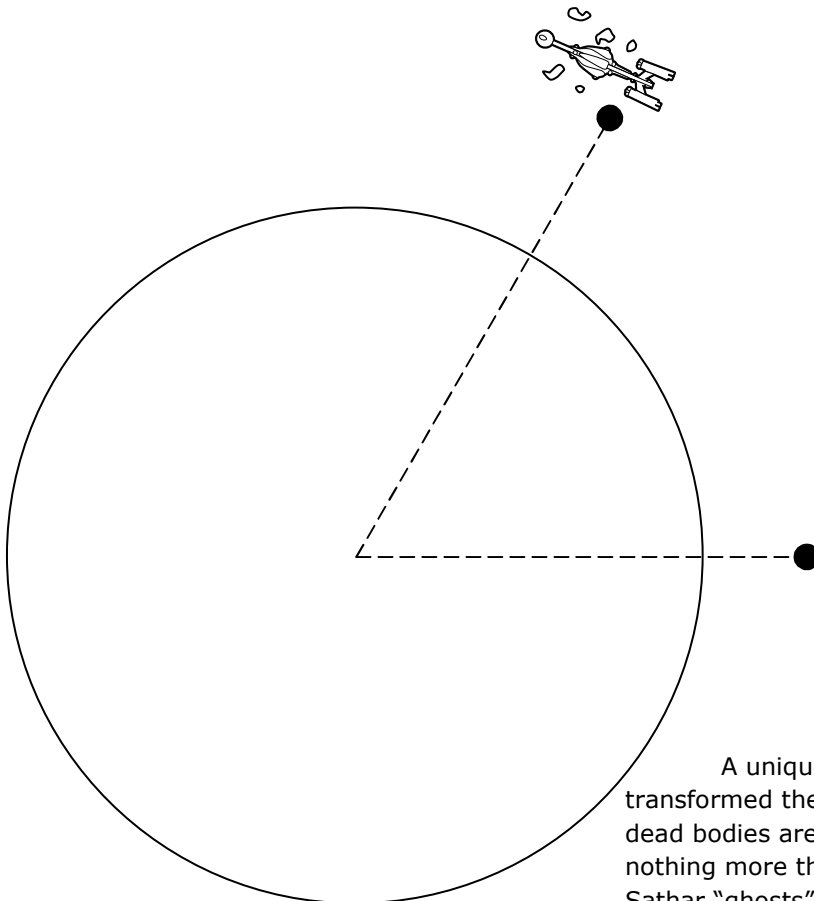

Communication was lost just before reaching the vessel and they have not responded for 6 hours. Unwilling to leave their fellows behind the captain of the mining vessel sent a distress signal via subspace to the nearest UPF outpost. Fortunately, an inbound/outbound ship receives the distress and can easily change course to reach the L4 point. ETA 28 hours... the heroes have that long to get ready.

### BOO!

A unique radiation from the gas giant has transformed the Sathar into apparitions. Their long dead bodies are still in hibernation chambers but are nothing more than husks. During the long years the Sathar "ghosts" went insane. When the PC's enter the ship they will swarm, swoop, growl, bite or do whatever to the PC's but they are completely harmless, however their craftiness still remains. The apparitions will lead the PC's to the maintenance shop where several combat robots will activate and attack.

# THE KEEP IT ROLLING STORY

**Authors Note:** I love community fan fiction. Here you will find a short story co-authored by the Star Frontiers community. Each contributor played off the previous post. It was fun! You never know which way the story will take. I've include NPC stats and a mini-map if you would like to run the Adventure! Please let us know how it goes. – Larry Moore

NOTE: If you would like to "keep it rolling" you can write [submissions@starfrontiersman.com](mailto:submissions@starfrontiersman.com) or post at <http://starfrontiers.us/node/2597>.

Ouch! My head. Wher... where am I?

As the fog dims around your eyes you find yourself on top of a crate in a very large room. Boxes are scattered everywhere. You are wearing a light blue jump suit. The designations and insignias have been ripped off it. You have a holster that looks like it contained a pistol Gyrojet pistol. From your vantage point you can windows mounted every 20 feet along the walls, it appears to be dark out. The room is dimly lit.

You rub your eyes and breathe in deeply. As soon as you do, you regret it. The fog that was dimming around your eyes smells of sulfur and brimstone. Your entire body aches in every joint, and you can hear nothing. You look around the room in the still silence, wondering what happened. Slowly, you begin to remember the recent events.

It was a concussion grenade. It threw you at least three meters. You were supposed to be escorting someone... someone important... but it all went wrong, so horribly wrong.

As your mind ponders the recent events... Suddenly the silence is broken by a rick rattle roll coming behind one of the crates. Slowly, ever so slowly you peer around the corner...

And you see two yazirians wearing black corporate uniforms, and they are carrying the best weaponry that can pack the biggest punch. They are looking through the unconscious bodies of the security team and V.I.P. you were in charge of...

Pondering your options you think the best course of action is to wait and see where the thugs go hoping to surprise one of them and get some gear.

"Wowzers, I never seen gear like that..." You whisper...

You hear one of the Yazirians start talking into his chronocom. "Sir we have eliminated the guard around the V.I.P...." The Yazirian cuts his conversation short as he spots you looking over at him...

The grizzled Yazirian keeps a steady gaze on me and his lips peel back in a vulpine grin. His right hand retrieves a palm sized cylindrical tube and he activates a sonic sword. The high pitched hum of the sword startles me to my senses. I get to my feet and dash away. I can hear the Yazirians bare claws skitter on the concrete as they give chase. I see a door at the far end of the warehouse. I sprint to the door hoping that it is open.

Whew! The door is unlocked; But not for long. THUMP! The big Yazirian is trying to force the door open. Turning around I see a set of stairs going down and up. Which way to go? Which way to go?

No time!

The door flies open, and I take the stairs going down, two steps at a time. I can almost feel the monkey's hot breath on the nape of my neck, spurring me to go even faster, running down flight after flight, seeming to lead down into the planet's molten core, judging from the stifling heat building with each flight I descend. It seems like these stairs go on forever, for just as I resign myself to that fact, I slam face-first into another door.

This one says "AUTHORIZED PERSONNEL ONLY!" in both Pan-Gal...and apparently in a language not conforming to any in the known Frontier, least I've never seen the ideograms inscribed below the more-plainly written warning.

Doesn't really matter either way...this door's not only locked, but there's no apparent lock mechanism to pick.

I mutter to myself, "No turning back", as I hear the padding of Yazirian feet on the stairs just above....

Quickly I slip my thin frame between two sets of stairs hoping to grab the Yazirians heels so he falls forward hitting the wall. My only chance... Hope he has a thin skull!

Time seems to slow. Every footstep pounds in my ear, BOOM, pause, BOOM, pause...

He is just above me. My hands shaking I see his hairy foot hit hard on the step. Reach, grab, I got him! I hold on with all my strength.

"What the...." SMACK! A spatter of blood marks the wall where his head hit, his limp body eases to the floor.

I don't hear anyone else coming down the stairs yet. I check the Yazirian quick. I find a shoulder holster with a laser pistol and two extra clips. I also find a wallet with an id card. I quickly retrieve the sonic sword that fell on the steps.

The metal door at the top of the stairs opens. I hear a chuckling Yazirian yell, "Korak!" again, "Korak, are you done playing with that human?" A long silence. I hear feet start to rush down the steps.

plate back in place. It ignores me. It has a cart near it with spools of optic cable and a tool box. I look to see if there is anything I can use.

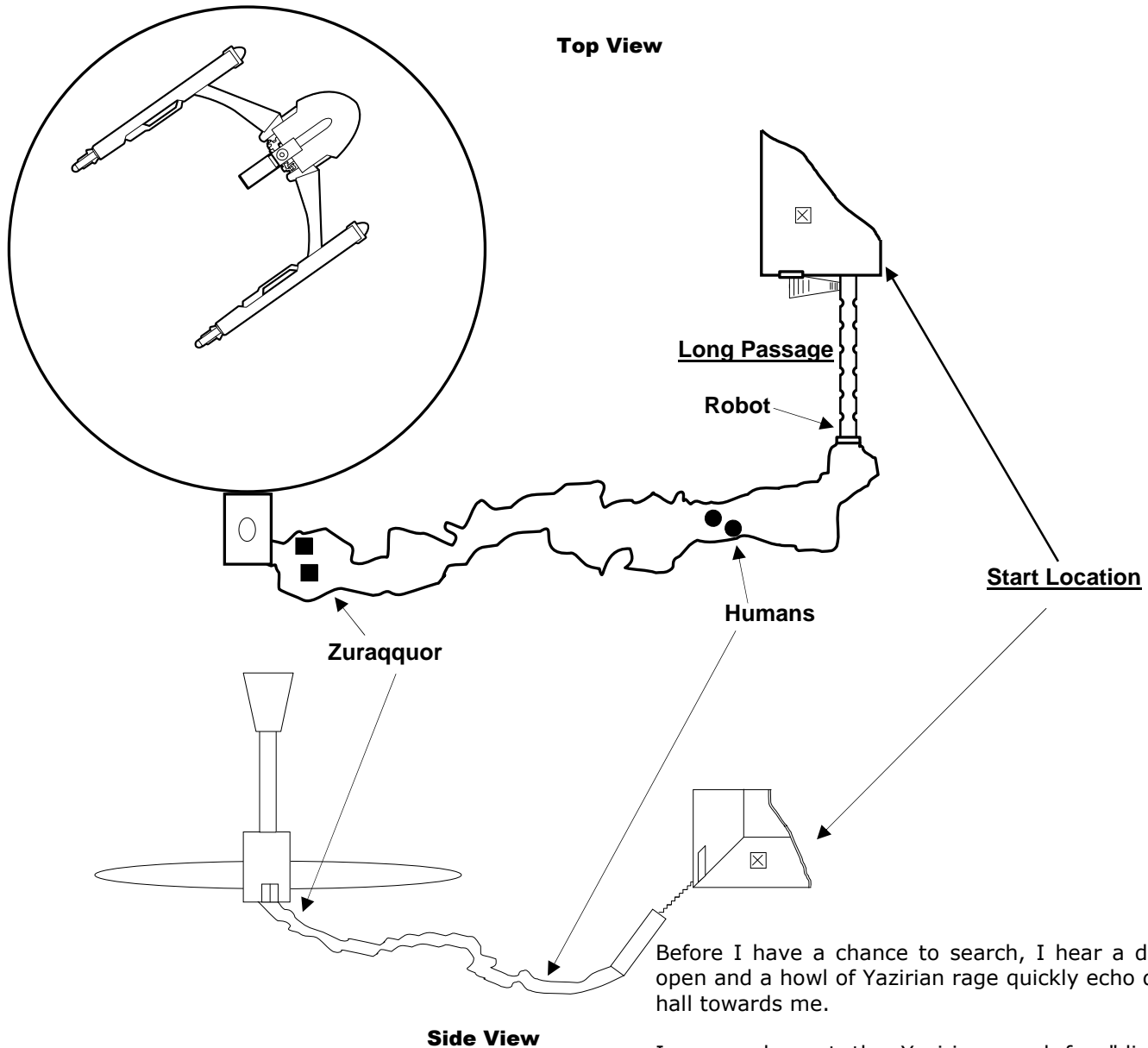

Before I have a chance to search, I hear a door slide open and a howl of Yazirian rage quickly echo down the hall towards me.

Quickly, I try the card in the door. It opens to a long passage. I hear the Yazirian reach his companion as I slam the door and lock it from my side with the card. I can hear him pounding on the door as I start to run down a concrete tunnel. It seems to stretch on forever. I wonder why he doesn't have his own ID card or why he hasn't blasted the lock.

I can make out the Yazirian word for "die" and a Yazirian expletive.

The passage has 'everglow' strips evenly spaced along the floor that dimly lights the passage. The tunnel has pipes and conduits lining it. I start to feel tired from running and start to slow my pace. I guess I have ran about a click when I see a flickering light ahead. As I get closer I see a maintenance 'bot welding an access

So, I draw the late Korak's blaster, dial it up to setting 5, and run like no tomorrow. Towards a pair of human soldiers in skeinsuits, both of whom are aiming needler rifles dead at me.

I see a patch on the right shoulder of one of the soldiers, identifying him as Truane's Star military. "Where there's a Truane's Star marine, the stench of Streel always follows." I say to myself remembering the ancient aphorism. I fire two pulses in quick succession at the soldiers while drawing and activating my sonic blade. The beams make pretty colors against their defensive screens, one of them burning straight through the chest of one of the soldiers, the sonic

blade squealing, as it gashes the arm of the other soldier, both of them spitting charged particles at my backside as I keep running turning down a corridor branching off to the right.

Bullets carom and spark off the wall behind me. I hear loud insectoid clicking coming from further ahead in the gloom. Not a Vruskian clicking, oh, no... When you work around bugs for a while, you just know the difference 'tween them and any other race of sentient insectoids.

Like, say, gnats....

Yep, definitely Zuraqqoor, four of them, judging by all the clicks and buzzes.

"Down on the ground, Star Law!" a deep Human male voice shouts from behind me, the voice adding, "Now, before we—"

Dumb vogger should've never asked me to get down on the ground, 'cause that's exactly what I do, get down on the ground, dropping to one knee and squeezing off the last two pulses left in the clip in the general direction of the Human voice, slapping one of the two extra clips in the blaster as the gnats open up again, Human and Yazirian male shouts and cursing indicating they've hit at least one of them.

I drain the second clip burning down the Zuraqqoor, as I take off running, needlers zapping and crackling entirely too close to my ears, frying my hair, the smell of it burning. An annoying distraction.

"He said stunning force, you stupid vogs!" I hear another Human male voice bark out. "Stunning force, as in, he wants him captured alive."

I hear chuckling from behind me.

I didn't like the miserable slag we were supposed to be babysitting anyway, I think to myself, as I duck around a corner, especially not enough for this.

Last clip.

Four more shots.

Truane's Star marines and the VIP just around the corner.

No way to contact the Invincible.

"What a pretty fix I'm in", I think to myself as I make my way along the darkened corridor, and gods only know what kind of insanity's brewing up top in Gozzorf...that miserable vog we were escorting was supposed to keep the Vrusk and the others from tearing each other to shreds.

Needless to say, that's not gonna happen, I add, heavy boot steps a second or so behind me, as I keep moving forward.

#### Contributors:



CleanCutRogue



Gergmaster



umungus



Will

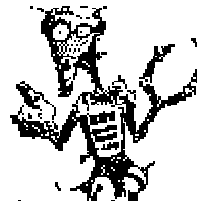

w00t

### Schert, Human

Current STA  
45

IM  
+5

STR	45	STA	45
DEX	35	RS	50
INT	45	LOG	40
PER	35	LDR	45

Special Abilities: N/A  
PSA: Military  
Skills: Melee 2 - Thrown 2

Weapons: Vibroknife, Whip, Auto Rifle

Ranged  
18

Melee  
23

Defenses: Military Skeinsuit

### Whament, Human

Current STA  
50

IM  
+4

STR	35	STA	50
DEX	35	RS	40
INT	35	LOG	35
PER	55	LDR	40

Special Abilities: N/A  
PSA: Military  
Skills: Projectile 1, Melee 1

Weapons: Auto Pistol, Knife

Ranged  
18

Melee  
18

Defenses: Military Skeinsuit

### Shez, Yazirian

Current STA  
50

IM  
+4

STR	55	STA	50
DEX	50	RS	40
INT	50	LOG	35
PER	45	LDR	35

Special Abilities: Night Vision, Gliding, Battle Rage 7%  
PSA: Military  
Skills: Melee 1, Beam 1

Weapons: Laser Pistol, Axe

Ranged

Melee

Defenses: N/A

### Kornak, Yazirian

Current STA  
55

IM  
+6

STR	45	STA	55
DEX	45	RS	55
INT	45	LOG	45
PER	45	LDR	35

Special Abilities: Night Vision, Gliding, Battle Rage 5%  
PSA: Military  
Skills: Projectile 1, Thrown Weapons 1

Weapons: Assault Shotgun, Knife

Ranged  
23

Melee  
23

Defenses: N/A

### Zuraquor, One

Current STA

IM

STR		STA	
DEX		RS	
INT		LOG	
PER		LDR	45

Special Abilities:  
PSA:  
Skills

Weapons:

Ranged

Melee

Defenses:

### Zuraquor, Two

Current STA

IM

STR		STA	
DEX		RS	
INT		LOG	
PER		LDR	45

Special Abilities:  
PSA:  
Skills

Weapons:

Ranged

Melee

Defenses:

Character

Current STA

IM

STR		STA	
DEX		RS	
INT		LOG	
PER		LDR	

Special Abilities:  
PSA:  
Skills

Weapons:

Ranged

Melee

Defenses:

Character

Current STA

IM

STR		STA	
DEX		RS	
INT		LOG	
PER		LDR	

Special Abilities:  
PSA:  
Skills

Weapons:

Ranged

Melee

Defenses:

# CHARACTERS WITH CLASS

Bill Logan

**Editor's Note:** Bill and I were kicking around ideas to "level" characters in Star Frontiers. Over coffee we had attributed "level" to gear. The better the gear that matched a situation the higher the level. Curious about what others were doing I posted on several different Star Frontier sites asking questions about level. Everyone came to just about the same conclusion. With the system below it's now very easy to build PC's (and NPC's) for adventures. Imagine a Referee asking, "Let's play on Saturday night, bring a Level 3 character."

*Now you can!*

## CHARACTERS WITH CLASS

Not everyone likes the class-and-level games popular today, but few can deny the role those types of games have had on the industry. Star Frontiers is a skill-based game, albeit one with very few skills. This article suggests that, with a little bit of forethought, Star Frontiers can also be made into a class-and-level game system.

When creating an adventure, class-and-level systems are great for assessing game balance. For instance, when playing the ever popular Dungeons & Dragons game most Dungeon Masters know how many goblins to throw at a party of three third-level characters to make the encounter challenging. In Star Frontiers, it's really difficult to assess things like that.

The rules presented in this article do not deviate from standard Star Frontiers experience point system presented in the Alpha Dawn boxed set. If you use house rules variants (such as those provided in the back of the Digitally Remastered version, or some of the articles presented in this webzine), you will have to make adjustments to the guidelines presented.

Looking through various published adventures, it's not surprising that the example characters provided for players to use are seldom balanced against one another. For a character to be effective, he must be good at what he does. Sadly, some professional pursuits are more costly to become good at. For instance, a soldier can quickly become an expert with weapons in the Star Frontiers game because of the relative inexpensiveness of those skills. A similar character whose player opts for a more scientific route quickly finds that growth in these skills pales in comparison to his friend's militant characters. So how do we assess character level of experience?



Artwork by C. J. Williams

## EXPERIENCE LEVELS

An experience level represents the general power of a character. This might not take effect as more combat ability; it might not even take effect as being able to take more damage. Since Star Frontiers is not modeled that way, game mechanics don't support balancing character development by combat effectiveness alone. Instead, a character's experience level is an assessment of how many experience points have been spent on the character to date.

## TRACKING EXPERIENCE POINTS

When your Referee doles out experience points at the end of a session or game, you typically record them on your character sheet as "Unspent" points. Once spent, they disappear forever and it's quite difficult to assess the experience level of the character. To be able to track experience levels, this has to change.



Using this optional rule, you no longer “spend” experience points developing your character. You simply accumulate them. Once you’ve reached enough accumulated experience points to rise in experience level, you simply record the new level and the benefits it provides (depending on the character class you selected). For instance, once you’ve earned more than 25 experience points with a character, you’ve become level 2. Refer to the following table for standard experience point totals per level.

**Table 1: Level Advancement Table**

Experience Points	Level	Rank
0-24	Level 1	Novice
25-49	Level 2	Journeyman
50-99	Level 3	Professional
100-149	Level 4	Elite
150-249	Level 5	Expert
250...	Level 6	Master

**Author’s Note:** This progression assumes that a character receives somewhere between 3 and 7 experience points per session, as per the Alpha Dawn game guidelines. Therefore, a Novice is a character which has been played in somewhere between 0 and 4 sessions. A Journeyman is a character that has endured somewhere between 5 and 9 sessions, etc. A Master has been through 50 sessions and survived... he’s probably got enough gear and skill to handle whatever comes his way. Of course, some Referees might want to have characters develop more quickly than the guidelines in the Alpha Dawn game – such players simply progress in experience levels more rapidly.

**Rank** This is just for depictive purposes. It is convenient for an adventure to say “This adventure is designed for a party of 3-5 Elite-level characters.” However, Rank is optional and you can feel free to ignore it. Or in the case of character classes specific to a game’s setting, replace the named ranks with names more appropriate to the character class, such as militant ranks, noble titles, or corporate honorifics.

## CHARACTER CLASS

Refer to the descriptions of the four core character classes on the pages which follow. These character archetypes are commonly found all throughout the frontier, in any type of setting. Referees wishing to create new character classes to suit specific needs of their own settings will want to read the sections below on **Creating a New Character Class**.

A character class is a series of pre-spent experience points. However, in order to make the player have some options, some experience points are spent on pre-specified things, but others are spent on categories of things from which the player may choose.

*For instance, a Techex character class allows a starting character to select any one skill from the Technological PSA at level 1, and any skill from the Military PSA at level 1. An Explorer, on the other hand, receives level 1 in the Environmentalist skill and may select any one Technological skill at level 1. The techex has more*

*flexibility because it’s important for the Explorer to begin play with survival skills that come from the Environmentalist skill.*

## CHARACTER CREATION

When creating a character in a game where Referees are using this *optional rule*, you simply roll your ability scores, choose a race, and select a class below (Enforcer, Explorer, Scispec or Techex). Write down whatever you get for that character class at level 1 (usually just a PSA, two skills, and some equipment), then roll d100 and spend that many Credits on any additional equipment you want.

*For instance, Stephanie is creating a character. She gets out dice and rolls them, creating ability scores in the normal fashion. She assembles them on her character sheet and shifts points among those in a pair. She selects a race and notes the racial abilities (she chooses a Yazirian and notes the ability score modifications as per normal). So far, this is all standard character creation rules from the Alpha Dawn game.*

*Next, she looks through the character classes and selects the Techex. She notes that the Techex has the Technological PSA, and according to table 5 she is permitted to select one Technological PSA skill and one Military PSA skill. She selects Robotics and Projectile Weapons, both at level 1. She writes down the starting free gear described in the class description (Robcomkit, Chronocom, Sonic Knife, Everflame, Gas Mask, 1 Solvaway, and a Doze Grenade) and rolls d100 for additional starting Credits, buying any additional gear she chooses.*

## CREATING HIGH-LEVEL CHARACTERS

Creating starting-level characters using character classes can be quick and easy, but what really makes this system helpful is when the Referee wants to run a game with higher-level characters. If the Referee requests you to make a character of experience level 3, for instance, you simply receive everything listed in the class description at levels 1, 2, and 3. When being asked to create a character of a higher level, use the following guidelines for purchase of gear:

**Table 2: Characters of Varying Levels**

Experience Level	Starting Equipment
Level 1	Class starting gear +d100 Cr
Level 2	Class starting gear +2,000 Cr
Level 3	Class starting gear +5,000 Cr
Level 4	Class starting gear +20,000 Cr
Level 5	Class starting gear +50,000 Cr
Level 6	Class starting gear +150,000 Cr

**Author’s Note:** The above assumes most sessions lasted around 3 days and earned the character a fair wage (see below, “Playing a Character Class”), but also assumes the acquisition of gear while adventuring as well as the depletion of Credits due to cost of living, ammunition and energy use on missions, etc. It is a good guideline but can be modified by Referees who tend to give out more or less money in-game.

# ENFORCER CHARACTER CLASS

The purpose of the enforcer profession is to provide protection and enforce federation or planetary law, corporate rules, or employer interests, whichever fits the character's occupational standing. Typical enforcers work as Star Lawmen, corporate security personnel, private investigators, and mercenary soldiers. Enforcer is a general character class dealing with combat expertise. Because of this, they tend to have inexpensive skill development costs and develop dexterity and stamina more than the other character classes. As an enforcer advances in experience level, he often has the many scars of previous engagements as evidence of his accomplishments.

**Primary Skill Area:** *Military*

**Starting Equipment:** *Gyrojet Pistol, 1 spare pistol jetclip, 2 fragmentation grenades*



Artwork by C. J. Williams

**Table 3: Enforcer Class Advancement**

XP	Level	Rank	Benefits
0-24	1	Novice	Acquire 2 Military skills, both at lvl 1
	2	Journeyman	Add 5 to STA score Acquire one Technological skill at lvl 1 Acquire two more Military skills at lvl 1 Advance Military skill to lvl 2
50-99	3	Professional	Add 10 to DEX score Advance one lvl 1 Military skill to lvl 2 Advance one lvl 2 Military skill to lvl 3
100-149	4	Elite	Add 5 to DEX score Add 5 to STA score Acquire one Military skill at lvl 1 Acquire one Biosocial skill at lvl 1 Advance one lvl 1 Military skill to lvl 2 Advance one lvl 2 Military skill to lvl 3 Advance one lvl 3 Military skill to lvl 4
150-249	5	Expert	Add 10 to STA score Acquire Military skill at lvl 1 Advance lvl 4 Military skill to lvl 5 Advance lvl 1 Technological skill to lvl 2 Advance one lvl 1 Military skill to lvl 2
250+	6	Master	Add 10 to DEX score Add 7 to RS score Acquire one Technological skill at lvl 1 Acquire one Biosocial skill at lvl 1 Advance one lvl 1 Biosocial skill to lvl 2 Advance one lvl 1 Military skill to lvl 2 Advance one lvl 2 Military skill to lvl 3 Advance one lvl 3 Military skill to lvl 4 Advance the lvl 5 Military skill to lvl 6

**Optional:** As enforcers advance in level, their reputation and skill often draws like-minded people to them. This is often how resistances are formed, or mercenary companies. If Referees prefer this rule, allow characters to roll on the Body of Followers table, below, upon reaching the 200XP mark. The followers will be loyal and follow chain of command, but need housed and fed and equipped. They may raise in level as the Referee permits over time.

**d10 Body of Followers**

**1 2d10 Demolitions Experts**

*Military PSA, Demolitions 1, Environmentalist 1  
Equipment: Skein Suit (military), Tornadium D-19, 4 frag grenades*

**2 2d10 Martial Artists**

*Military PSA, Unarmed Combat 1, Melee Weapons 1  
Equipment: Nightsticks, Skein suit (civilian)*

**3-4 2d10 Sharpshooters**

*Military PSA, Projectile Weapons 1, Technician level 1  
Equipment: Autopistol, Autorifle, 4 spare mags each, Techkit*

**5-6 2d10 Space Marines**

*Military PSA, Beam Weapons 1, Computers 1  
Equipment: Laser Pistols, 4 PowerClips*

**7-8 2d10 Star Soldiers**

*Military PSA, Gyrojet Weapons 1, Robotics 1  
Equipment: Gyrojet Rifle, 4 mags, Military Skein Suit, Robcomkit*

**9 2d10 Weaponers**

*Military PSA, Melee Weapons 1, Medic 1  
Equipment: Sonic Sword, 2 PowerClips, Medkit*

**10 Special!**

*Referee's choice relevant to setting. Perhaps it's a captain of a small starship, or an unusual race/creature type.*

# TECHEX

## CHARACTER CLASS

Techex is the common name given to a member of the Technical Expert profession. The techex's job is to build, direct, maintain, and repair his employer's technical equipment, computers, and robots. Typical positions held by a techex include Star Law computer expert, corporate robotics development, research and maintenance personnel, private contractor, or technology. Often riddled with attention deficit disorder and full of hyper energy, a techex lives on caffeine and instant food, his fingers seldom far from a tool or keypad.

Techex characters tend to speak in technical jargon and sometimes find themselves trailing off the current line of discussions after noticing everyone staring blankly and nodding, not sure what the heck is being said. Techex characters are the mechanics and electricians of the frontier. They can be as gruff and tough as a hardened hovercraft mechanic, or as small and awkward as a stereotypical programmer type.

**Primary Skill Area:** *Technological*

**Starting Equipment:** *Techkit or Robcomkit (depending on starting skill selection), Chronocom, Sonic Knife, Everflame, Gas Mask, 1 Solvaway, Doze Grenade*

**Table 4: Techex Class Advancement**

XP	Level	Rank	Benefits
0-24	1	Novice	Acquire lvl 1 Technological skill Acquire lvl 1 Military skill
25-49	2	Journeyman	Add 5 to LOG score Acquire lvl 1 Military skill Acquire lvl 1 Technological skill Advance one Technological skill to lvl 2
50-99	3	Professional	Add 5 to INT score Acquire lvl 1 Technological skill Advance lvl 1 Technological skill to lvl 2 Advance lvl 2 Technological skill to lvl 3
100-149	4	Elite	Acquire Biosocial skill at lvl 1 Advance lvl 2 Technological skill to lvl 3 Advance lvl 3 Technological skill to lvl 4 Advance lvl 1 Military skill to lvl 2
150-249	5	Expert	Add 5 to LOG score Acquire Military skill at lvl 1 Advance lvl 1 Military skill to lvl 2 Advance lvl 1 Technological skill to lvl 2 Advance lvl 4 Technological skill to lvl 5
250+	6	Master	Add 5 to INT score Add 5 to LOG score Advance lvl 2 Technological skill to lvl 3 Advance lvl 3 Technological skill to lvl 4 Advance lvl 5 Technological skill to lvl 6 Advance lvl 2 Military skill to lvl 3 Advance lvl 1 Biosocial skill to lvl 2

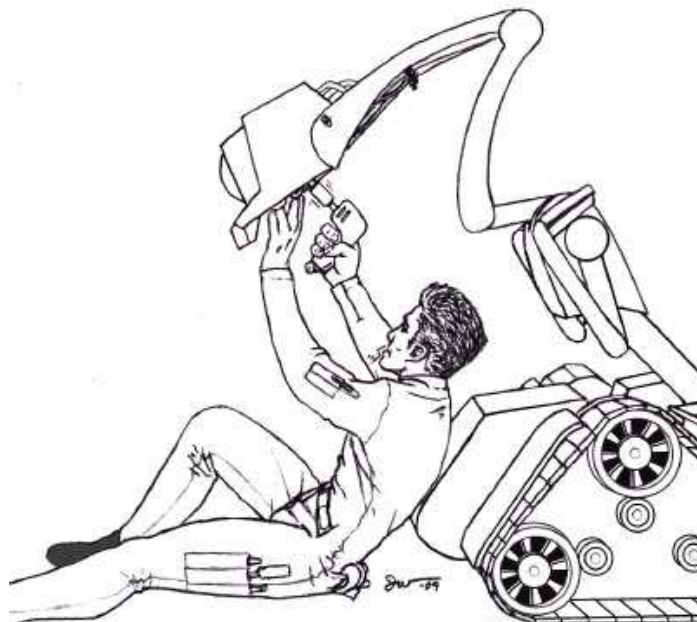

Artwork by C. J. Williams

**Optional:** Characters playing the Techex character class are so good with electronics, technology, and software that they find it easy to associate with like-minded people, building a network of contacts. This network is two-way; if a technician draws on the expertise of a computer expert friend, that computer expert will probably call on the technician in the future. Every 100XP earned, the Techex gains an additional Contact. This is not a follower like the Enforcer Class, though there is certainly some professional loyalty involved. The player selects one of the following:

**Computer Expert** - *The character knows someone who knows computers inside-and-out, able to accomplish things not covered by adventuring skills. He probably only knows him by some hacker name or code name. The contact will do favors for him but not for free - Credits (1d10x100 is typical, up to 10x that figure for illicit activities) must be transferred to some secret account number that seems to change every time.*

**Robotics Expert** - *The character knows someone who knows robots inside and out, able to get parts that nobody else can get. Even replacement parts for robots illegal to own... black market parts for a dangerous frontier. He charges twice the normal price, but can get parts to you in a jiffy. He may also be helpful when needing to get info out of a robot that has been destroyed. The contact works at some Corp and freelances on the side... but he'll never tell you for which corp he works!*

**Technician Expert** - *The character knows someone who can do things to vehicles that defy the normal technician skillset. He tricks out vehicles, adds things that would get the character arrested if discovered. He can also file off those vehicle identification numbers or sell the character a quick vehicle. The tech contact owns a shop on a world the character frequents, and often has new interesting things to offer the character. If the player has his vehicles serviced at this contact's shop, he can have a 25% boost to all vehicle statistics (cruise speed, top speed, etc.)*

# SCISPEC CHARACTER CLASS

Scispec is the common name given to a member of the Scientific Specialist profession. The job of the scispec is to oversee scientific expeditions, conduct experiments, provide medical aid, and know the way people think – sometimes before they think it. For an adventuring character class, this is by far the most academic. Characters of this profession are probably university graduates and often come from a family background with money to spare.

Typical positions held by a scispec include Star Law science specialist, Star Law medic, exobiologist, corporate research expedition member, and independent doctor. Although many scispec non-player characters spend their lives in labs, seldom seeing adventure and excitement, the scispec character class assumes an adventuring scientist, one who learns to defend himself as needed.

Scispecs often find themselves inept in social environments – too used to dealing with other scientists than normal folks. This can lead to interesting role-playing situations.

**Primary Skill Area:** *Biosocial*

**Starting Equipment:** *Medkit or Envirokit (depending on starting skill selection), Gas Mask, 2 doses Solvaway, 10 days Vitasalt Pills, Toxy-Rad Gauge, Everflame, Chronocom, 2 Smoke Grenades*

**Table 5: SciSpec Class Advancement**

XP	Level Rank	Benefits
0-24	1 Novice	Acquire Biosocial skill at lvl 1 Acquire Technological skill at lvl 1
25-49	2 Journeyman	Add 5 to LOG score Acquire Biosocial skill at lvl 1 Acquire Military skill at lvl 1 Advance lvl 1 Biosocial skill to lvl 2
50-99	3 Professional	Add 5 to LOG score Acquire Biosocial skill at lvl 1 Advance lvl 2 Biosocial skill to lvl 3
100-149	4 Elite	Acquire Technological skill at lvl 1 Advance lvl 1 Biosocial skill to lvl 2 Advance lvl 1 Biosocial skill to lvl 2 Advance lvl 3 Biosocial skill to lvl 4
150-249	5 Expert	Add 5 to LOG score Add 5 to DEX score Acquire Military skill at lvl 1 Advance lvl 1 Military skill to lvl 2 Advance lvl 4 Biosocial skill to lvl 5
250+	6 Master	Add 5 to DEX score Add 5 to LOG score Add 5 to INT score Acquire Military skill at lvl 1 Advance lvl 2 Military skill to lvl 3 Advance lvl 1 Technological skill to 2 Advance lvl 2 Biosocial skill to lvl 3 Advance lvl 5 Biosocial skill to lvl 6



Artwork by C. J. Williams

**Optional:** As the most academic of the character classes in the frontier, science specialists (scispecs) learn things a bit faster than others. Sadly, due to the slow progression of biosocial skills, this is not obvious when looking at game mechanics in the Star Frontiers game. If Referees wish to allow it, SciSpec character can use this optional rule.

Each 50XP earned, the player may select one area of obscure knowledge from the following list. These are fields of expertise that the Alpha Dawn core skill system has no provision for. If the Referee permits, the player may suggest a field not shown on this list.

The character is considered adept at this field of study, sufficient to work in that field as a professional. Between adventures, the Referee may even allow an earned income to reflect this field of expertise. The character's expertise in this field may even be the catalyst for some adventures.

In any ability check or skill check where the Referee believes the field of study is appropriate, the character receives a +10 to his chance of success. Only one field of study may apply (if two seem relevant, the bonus is still only +10).

- » *Artist*
- » *Culture Expert*
- » *Detective*
- » *Economics*
- » *History Expert*
- » *Legal Expert*
- » *Linguist (gain one additional language, free)*
- » *Political Expert*
- » *Religion Expert*
- » *Scientist (specific field of study: botany, chemistry, physics, archaeology, biology, metallurgy, genetics, etc.)*

# EXPLORER

## CHARACTER CLASS

The purpose of the explorer profession is to operate alone or in small groups on an unexplored planet or as guides or scouts for scientific or military expeditions. Typical positions held by explorers include Star Law scout, mercenary strike force or commando team member, corporate spy, and advance emissary to primitive cultures.

Although in class Star Frontiers Alpha Dawn, there are very few skills appropriate for an explorer, this class shows how the Environmental skill (as well as a healthy dose of ability score increases and several other skills) can be used to create an effective scout character. Because of the varied nature of the role an explorer plays in the frontier, he is often a jack-of-all-trades rather than a master of any one. In the end, he will have all technological and biosocial skills at one level or another... and a healthy dose of several military skills as well.

This class, since it combines the abilities one would expect from an espionage agent, wilderness scout, and environmental scientist, is especially diverse. However, in combat it is less than some might desire. Keep in mind that players can equip their characters with weapons even if they lack the skill, and melee weapons often come with a bonus to hit, which can help offset the fact that the character lacks the skill to wield the weapon effectively.

**Primary Skill Area:** *Biosocial*

**Starting Equipment:** *Envirokit, Vibroknife, Sword, All-weather blanket, Compass, Everflame, Flashlight, Gas Mask, Holo flare, Life Jacket, Rope, 2 doses Solvaway, Sungoggles, 10 days survival rations, Toxy-Rad Gauge, 10 Vitasalt Pills, Waterpack.*

**Table 6: Explorer Class Advancement**

XP	Level	Rank	Benefits
0-24	1	Novice	Acquire Environmental skill at lvl 1 Acquire Technician skill at lvl 1
25-49	2	Journeyman	Add 5 to RS score Add 5 to DEX score Acquire Military skill at lvl 1 Advance lvl 1 Environmental skill to lvl 2
50-99	3	Professional	Add 5 to RS score Acquire Military skill at lvl 1 Advance lvl 2 Environmental skill to lvl 3
100-149	4	Elite	Add 10 to STA score Acquire Biosocial skill at lvl 1 Acquire Technician skill at lvl 1 Advance lvl 1 Technician skill to lvl 2 Advance lvl 1 Military skill to lvl 2
150-249	5	Expert	Acquire Military skill at lvl 1 Advance lvl 1 Military skill to lvl 2 Acquire Technological skill at lvl 1 Acquire Biosocial skill at lvl 1 Advance lvl 3 Environmental skill to lvl 4
250+	6	Master	Add 5 to RS score Advance lvl 3 Technician skill to lvl 4 Advance lvl 1 Military skill to lvl 2 Advance lvl 2 Military skill to lvl 3 Advance lvl 1 Biosocial skill to lvl 2



Artwork by C. J. Williams

**Optional:** Every 50XP earned, the player may select one of the following specialty skills. These are not treated as normal skills and do not advance with level. They are special abilities the Explorer can perform.

- » **Animal Handling** – the Explorer can influence the behavior of an animal, break a riding beast, train them for hunting, etc.
- » **Area Knowledge** – the Explorer gains an intimate knowledge of a specific area specified when selecting this skill. He can live off the land there indefinitely, and knows shortcuts.
- » **Body Language** – the Explorer can communicate with other Explorers silently, using hand/body motions. Additionally, with an INT check, he can guess at the general mood of someone he studies.
- » **Camouflage** – with an Intuition check, the Explorer can hide something in a natural surroundings. Someone must make an Intuition check to see through the concealment.
- » **Disguise** – with a LOG check, the Explorer can disguise himself. A -20 penalty applies if trying to resemble a specific other person. An Intuition check is required to see through the disguise.
- » **Expert Liar** – with a Personality check, the Explorer can fool a Dralasite who otherwise may have succeeded in his Detect Lie racial ability.
- » **Forgery** – with a Dexterity check, the Explorer can forge a license, letter, signature, etc. if material is at-hand. An Intuition check can see through a Forgery.
- » **Hard Target** – the Explorer is so light on his feet that all enemies have a -10 to hit him at all times, as long as the Explorer is aware of the incoming attack.
- » **Mariner** – the Explorer can swim expertly, make and operate rafts and canoes, and can produce bountiful fish for eating.
- » **Trailblazing** – the Explorer can ignore the movement penalties associated with one specific terrain type.

## PLAYING A CHARACTER CLASS

Playing a character created from a character class is no different than playing one created in the traditional manner. As level increases, so too does the character's respect within the community he works. His ability to earn a high wage increases also, as does his employer's confidence in his ability to accomplish the more dangerous missions. Some guidelines are below:

- **Level 1:** Characters at experience level 1 are mere novices and are often sent on missions with a professional NPC as a commander. Novices typically receive around 50 credits per day of work, but might make double that if the job is particularly dangerous. They are sometimes outfitted with gear by their employer but expected to return that gear (minus ammunition).
- **Level 2:** A character at experience level 2 can sometimes be sent on jobs without a commander, if the stakes are low enough or a professional-level character isn't available to come. Journeymen characters often earn around 75 Credits per day of work, double if the job is particularly dangerous. They are no longer equipped by their employers – at the rate they are being paid the character is assumed to be able to afford his own equipment.
- **Level 3:** Groups of professional characters are treated with a lot of respect with whatever employer they work for, and earn 100 Credits per day of work (double for particularly dangerous missions). He is expected to have any equipment needed for the right job. A professional is presented with classified information and must often sign non-disclosure agreements with his employer, which sometimes contractually binds him in other unexpected ways... always read the fine print!
- **Level 4:** The character has probably endured 20 sittings, and as such will already have a breadth of equipment at his disposal, acquired from his many missions. He is considered elite, and can charge 200 Credits per day of work (and might be able to negotiate almost double that for particularly dangerous missions). He has a solid reputation with potential employers, and can freelance with other agencies unless contractually bound.
- **Level 5:** The expert has lived through 30 game sessions, and unless he's botched them all has accomplished many missions for employers. He has such a diverse amount of equipment acquired through his adventures that he can survive nearly anything a mission throws at him, and employers

know that. That is why he is generally able to charge 400 Credits per day of work (and might even be able to negotiate up to double that if he can convince the employer of some great risk to his life – which is often difficult because it's the character's ability to survive difficult missions that makes him an expert in the first place.

- **Level 6:** A character of this experience level can often set his own daily rate of hire, and can turn down jobs because he often has another waiting in the wings. He typically charges around 600 Credits per day – but this can vary based on the needs of the mission. Masters of a vocation have endured around 50 adventure sessions and have performed amazing feats that others have heard of... they are legendary figures in the frontier, talked about by children and envied by other adventurers. They have many friends and probably an equal number of enemies.

**Table 7: Income by Level**

Level	Daily Pay
Level 1	50 Credits per day
Level 2	75 Credits per day
Level 3	100 Credits per day
Level 4	200 Credits per day
Level 5	400 Credits per day
Level 6	600 Credits per day

\* Cr per day will be more if mission is extremely dangerous

### LIFE PAST EXPERIENCE LEVEL 6

Once a character reaches Master level in his character class, the player is in charge of spending any additional earned experience points. No matter how many experience points he earns and spends, he will always be considered level 6, a Master.

## CREATING A NEW CHARACTER CLASS

Although the four core character classes are pretty sufficient to handle most game settings, Referees may wish to customize their campaign by creating custom classes. Creating a character class is very simple. You just pre-spend experience points appropriately. Below is a basic discussion for each level of experience. Use the four core classes as reference while reading these guidelines, and see the example at the end of this section.

### RACIALLY-SPECIFIC CHARACTER CLASSES

A Referee creating a character class might deem that it is racially specific. For instance, a Yazirian RiskJumper might be a class specific to Yazirians – one that leaps from jetcopters at high altitudes and glides down on unsuspecting prey in the night. Although it could be made by use of the Enforcer character class, some Referees might want to create their own class to

represent this elite unit. In such a case, feel free to spend experience points on improving racial abilities (for instance, on Battle Rage in order to improve the likelihood of raging before hitting the ground) in the steps below.

## BALANCING THINGS

While following these steps, if you go over or under the target number of experience points by 1 or so, don't worry. Since a level represents a large range of experience point totals (for instance, an "Elite" leveled character represents experience point totals from 100 to 149), being off by one for the sake of creating a well-balanced/rounded character class level is not a big deal.

- **Level 1:** A character class is created by pre-selecting the profession's Primary Skill Area. Once selected, this determines the cost of experience point progression from that point onward, like always. Next, you pre-select the two starting skills to define the direction of the character class. Purchase 250 credits worth of equipment for the starting character (which admittedly doesn't give the character much!), and give it any free gear that comes with the skill selections (such as toolkits). Write all this down as description of what the character gets for free at level 1.
- **Level 2:** Now spend 25 experience points developing the character made in level 1. If the character class warrants it, feel free to use some of these points developing ability scores, buying skill levels, etc. If you purchase additional skills, either be specific if it is important to the character class description (such as "Robotics at level 1"), or general (such as "Select any one Technical skill at level 1"). Write down what the character receives at level 2. At this level, the character should probably have at least one skill at level 2. He may even have a skill as high as level 3, but try to also consider giving at least one or two other first-level skills to round out the class.
- **Level 3:** Spend another 25 experience points developing the character as it was advanced at level 2. Keep in mind that you might not have enough experience points to develop some skills at this level – for instance, it takes 30 experience points to buy a third level of a biosocial skill if you don't have a biosocial primary skill area. If it is absolutely mandatory for the character class concept for you to do so, feel free to save some of the experience points to add to those you'll use when defining level 4. After you've spent (or saved) the 25 additional experience points, write a description of what the character receives when he reaches level 3. At this level, a character is considered "professional" and

should have a diverse set of skills and probably one level 3 skill, as a general rule.

- **Level 4:** Spend another 50 experience points developing the character as it was advanced at Level 3. If you saved any experience points developing the character class at level 2, add them to the 50 you get to spend at level 4. Try to make at least one skill at skill level 4 (or more than one if possible) and don't forget to consider adding some points to ability scores (often developing Stamina is important to help the character endure more injuries and to represent the physical development off the character through all his hardships). Write down all a character gets for level 4.
- **Level 5:** Spend another 50 experience points developing the character as it was advanced at level 4. A character of this level is truly an expert in his field, well-respected and discussed. After spending the 50 experience points on the character, write down what the expert level character receives at level 5.
- **Level 6:** The character is truly a master of his class. Spend 100 experience points on the character, and make sure that at LEAST one skill is at skill level 6, and probably more than one in the chosen PSA. Write down what the character receives at level 6.

## MAKING CLASSES INTERESTING

Using these guidelines, any character class can be made. Star Frontiers, admittedly, has very few skills. Therefore, one way to differentiate the class from others is by use of starting gear. It's your campaign – feel free to violate the 250 Credit rule if the gear you're giving isn't too game unbalancing. Another way to help define the class is by giving unique rank titles/identifiers to each level that grant the character class specific in-setting benefits not related to skills.

*For instance, a Referee has a campaign where the Dralasite's special ability plays a vital role, where the little rubbery guys travel around like feared inquisitors with strange senses of humor. The Dralasite Detective class's levels might have rank titles like: Officer, Detective, Sergeant, Captain, Inspector, then Inquisitor. The Dralasite Detective Agency (DDA), which might be highly respected in the frontier, might enjoy special treatment depending on their level, such as free room and board at Sergeant and above, and complete royal treatment at Inquisitor level.*

Refer to the example which follows.

## EXAMPLE: VRUSK MERCHANT

Vrusks are often characterized as being quite capable corporate businessmen, but few people consider how effectively their Comprehension racial ability aids in merchant activities. A skilled merchant is one who recognizes the needs of a culture he visits – even if that culture doesn't realize what it needs. He must be able to comprehend the intricacies of the politics and corporate movements of a region. He must understand the corporate strategies of a board better than those mired of the game of thrones and pawns within it. In short, Vrusks would make great interstellar merchants.

The Empathy and Persuasion subskills of the Psychosocial skill make the best fit to represent haggling and interacting with different walks of life, while the Vrusk's Comprehension racial ability provides insight where skill falls short. Although military skills are not too necessary (a Vrusk Merchant would undoubtedly have an Enforcer escort if travelling in a dangerous area), having a single weapon skill to fall back on in an emergency is always a good idea. Finally, knowing something about what you sell is always important (to avoid being duped by clever patrons), so having at least a splattering of the technical skills might make good sense. Armed with these thoughts, the Vrusk Merchant character class might be defined as follows.

**Level 1.** We'll select Biosocial PSA, to give an experience point discount on the psychosocial skill. We'll specify that the character begin with level 1 in the Psychosocial skill and level 1 in any technological skill (presumably whatever type of gear the Vrusk would sell). For starting equipment, we would normally give 250Cr worth of gear and a techkit (because of the technological skill) but we'll violate a rule here, trading all starting money and gear for a Poly-vox, to allow the Vrusk to speak to any culture he encounters. We're the Referee. We can do things like that. As a rank title, we'll call a level 1 merchant a Salesman.

**Level 2.** We can spend 25XP on the class. We'll advance the Psychosocial skill to level 2 for 10XP, and purchase a level 1 military skill for 6XP to help the Vrusk defend himself (he's been through a couple adventures and probably deserves a gun skill by now). Finally, we advance the Vrusk's Comprehension racial ability by +4 (for 4XP) to 19%. This totals 25XP, but let's make the racial ability a nice round number by making it +5 instead. As a rank title, we'll call a level 2 merchant a Broker.

**Level 3.** We get to spend another 25XP on development. At this level, the merchant is a skilled professional. We'll add a whopping +10 to the Vrusk's Comprehension ability for 10XP, raising it up to 30% now. We'll give the merchant level 1 in the other remaining Tech skills (8XP each). That totals 26XP, which is one high. We'll leave it alone. The Vrusk now knows about all technological devices well enough to appraise them and sell them. He can defend himself if necessary, and is quite effective at persuasion. He's coming along. As a rank title, we'll call a level 3 character of this class a Trader.

**Level 4.** Now we get 50XP to spend. An elite merchant will undoubtedly need another level of Psychosocial skill, which costs 15XP. He can probably use another level in his chosen military skill for 12XP, but we'll first give him a second military skill at level 1 for 6XP so the player can choose which of the two to increase to level 2. We'll let him buy level 2 in one of his three level 1 technological skills for 16XP. This totals 49XP, close enough (since we went over on level 3). As a rank title, we'll call a level 4 merchant (surprisingly) a Merchant. He is assigned a single star system by his guild, and manages financial affairs by sometimes sticking his nose where it doesn't belong.

**Level 5.** The character is an expert – well renown among merchant circles, certainly one of the movers and shakers of the economy of a region. We get to spend another 50XP on development. It's tempting to buy the next level of Psychosocial, but we'll delay that until next level because the character has too few low-level skills and his Psychosocial is already level 3 by now, which is a professional level of effectiveness. We'll let the player raise his level 2 military skill to level 3 so he can be effective in a fight (enemies tend to try to double-cross famous people just for the fame it gains them!). This costs 18XP. We raise his two level 1 technological skills to level 2 for 16XP each. This totals 50XP and we're done with this level. Unhappy with the overall low skill levels (the character has nothing higher than skill level 3!), we'll decide that at this level the merchant is assigned two level 1 Enforcers as personal bodyguards. Although he must pay them a valid wage, they are loyal to the merchant guild to which the player's character belongs. As a level title, we'll call him a Merchant Lord.

**Level 6.** Now the character is a master merchant, a potent force in the frontier. We have 100XP to spend on developing the character and this time we want to make sure we add a level to his Psychosocial skill. But this time we'll raise it two levels since we have the points to spend. This costs 20XP to raise it to level 4, and 25XP more to raise it to level 5. We let him increase a level 2 Tech skill to level 3 for 24XP, and raise his level 1 military skill to level 2. Because of his reputation, we add +20 to his Leadership skill for 20XP. Finally, we increase the master merchant's Comprehension by +10 for 10XP. This brings his Comprehension score up to 50%. We have now spent a total of 99XP on level 6, which is close enough. As a rank title, we'll call the master merchant a Merchant Prince and assume he is given three connected star systems that he is in charge of – and nobody is permitted to sell in his region without getting a permit from him. Of course, not everyone follows Vrusk Merchant Guild laws...

## PUTTING IT ALL TOGETHER

The advancement of the Vrusk Merchant seems pretty clear. It is a strong archetype that has a good fit in a campaign setting. We've given the class a good assortment of skills but didn't really concentrate on trying to get a sixth level skill. That actually fits for this character class, since having rounded knowledge of



a large number of topics is vital to the success of a good merchant. To compensate, we've given him a strong presence in the setting by providing the merchant with bodyguards and regional responsibilities.

A good Referee will see great opportunities for adventure here: protection of cargo, recovering of reputation, obtaining great caches of sellable goods, obtaining trade secrets from corporate execs, catching smugglers, or even smuggling themselves!

## VRUSK MERCHANT

Although merchants of all races span the frontier and range from the lowliest store clerk to the mightiest arms dealers in war-torn cultures, the Vrusk often finds himself the leader of the trading pack. His skill with comprehending social, political, and cultural complexities makes him potent in financial situations. Add to that a healthy dose of psychosocial training and experience and you have yourself one persuasive merchant.

Although most people go their whole lives never getting involved in the politics of the merchant trade, none go their entire adventuring careers without buying goods. An adventuring merchant can find all manner of adventure all around the frontier, but most merchants settle in with one of the great merchant guilds to enjoy the protection and reputation that comes with them. At higher levels, a merchant who doesn't settle in with one of the merchant guilds loses out on some perks.

Some merchants run afoul of the law and settle in with crime syndicates, laundering ill-gained credits through seemingly plausible routes to keep them away from Star Law eyes. Others become smugglers, using their skills but keeping out of the purview of the larger guilds. Smuggling merchants find corporate executives are eager to work with anyone willing to undercut the large merchant houses.

**Primary Skill Area:** *Biosocial*

**Starting Equipment:** *Poly vox*

XP	Level	Rank	Benefits
0-24	1	Salesman	Acquire Psychosocial skill at level 1 Acquired any Technological skill at level 1
25-49	2	Broker	Add +5 to Comprehension racial ability Acquire any Military skill at level 1 Advance Psychosocial skill to level 2
50-99	3	Trader	Add +10 to Comprehension racial ability Acquire 2 Technological skills, both at level 1
100-149	4	Merchant	Acquire 1 Military skill at level 1 Advance Psychosocial skill to level 3 Advance any level 1 Military skill to level 2 Advance 1 level 1 Technological skill to level 2
150-249	5	Merchant Lord	Assigned a star system by guild to preside over financially Advance 1 level 2 Military skill to level 3 Advance 2 level 1 Technological skills to level 2 Assigned 2 level 1 Enforcers by guild as bodyguards
250+	6	Merchant Prince	Add +20 to Leadership score Add +10 to Comprehension racial ability Advance Psychosocial skill to level 5 Advance 1 level 2 Technological skill to level 3 Advance 1 level 1 Military skill to level 2 Assigned 3 star system region by guild to preside over

## FINAL NOTES

This system uses all normal Alpha Dawn game rules. Even the pay per day by level is drawn from the Alpha Dawn game. All this article proposes is staging development into fixed stages (levels) to simplify character development (especially development of higher level characters), provide a unified approach to game balance ("This adventure has been balanced for 3-5 Journeyman characters (level 2)."), and to provide a way to assess overall character experience. It does serve these purposes.

While playtesting this system, my family and I had a lot of fun. But one thing we noticed was that staging development into levels like this was very quick and rewarding at low levels, but once reaching level 4, advancement became slow. Level advancement occurs every five sessions or so until then, but then occurs around every ten sessions. Once level 5 is reached, it takes an average of 20 gaming sessions to achieve level 6. Going 10 or 20 gaming sessions with no character development to show for it can frustrate some players. However, keep in mind characters will be accumulating wealth, story-related status and contacts and renown, and equipment during these lulls.

Several ideas were presented by my family and one friend to mitigate this drawback, but in the end I opted to leave it as-is to keep with the classic Alpha Dawn character advancement rules. I did, however, add optional systems for each of the four core character classes to help round out their role in the frontier. Referees wishing to provide a more gradual level advancement could adopt other skill systems or could provide some other setting-based reward at every 25XP (such as contacts or similar – see next issue's Action Point article by me as one such suggested companion to this article).

Rather than add length and complexity to this article, I prompt others to submit additional character classes or variant rules for non-experience-point-based prerequisites obtained at 25XP intervals.

# STAR FRONTIERSMAN

C. J. Williams

## CONTENTS OF ISSUES 1-12

### ISSUE 1

**Equipment**

Beam Weapons ..... 1  
*Light Stunner Pistol, Blastpistol*

Projectile Weapons ..... 2  
*Simi-automatic Pistol*

Gyrojet Weapons ..... 2  
*Gyrojet Wristrockets*

Defensive Equipment ..... 2  
*Security Skeinsuit, Stealthskin*

Miscellaneous Equipment ..... 3  
*Duraraft, Envirotent, Jumpboots, Survival Kit, Visocom, Wide Field Recorder*

**Locations**

Evergloom, moon prison of Triad ..... 5

**Archetypes**

Dralasite Martial Artist ..... 6  
*Way of the Warrior, Undersport Champion, Visionary, Angry Blob, Protector of the Oppressed*

Vrusk Smuggler ..... 8  
*Courier, Dealer, Kidnapper, Reluctant Hero*

**Character Races**

Nagana ..... 10

**Adversaries**

Alpha Class Security Robot ..... 12

Beta Class Security Robot ..... 13

Gamma Class Security Robot ..... 13

**Optional Rules**

Experience Points ..... 14

Skills ..... 15  
*Specialization*

**Adventure!**

The Long Road to Rhald'ran ..... 16

The Fall of Tomorrow ..... 16

### ISSUE 2

**Technical Journal**

Computers ..... 1

New Items ..... 3  
*Voice Control, Speech Output, Somatic Control, Holographic Keyboard, Holographic Display*

**Star Systems**

Araks System ..... 4  
*Araks I, Araks II, Araks III (Hentz), Araks IV*

**Optional Rules**

Hit Location ..... 7

Getting Drunk! ..... 9

**Archetypes**

Human Systems Tech ..... 10  
*Robot Queen, Mr. Fixit,*

Yazirian Cyber Cop ..... 12  
*Innovative Street Cop, Fortress Security Agent, Pattern-Program Profiler*

**Equipment**

Projectiles ..... 14  
*CKA Fast Drawing Holster, Extended Bulletclips*

Plot Hooks ..... 15

Vehicles ..... 15  
*Infiltrator*

Tables ..... 16

**Locations**

Rockroost Mining Colony ..... 17

**Adversaries**

Creatures of Hentz ..... 18  
*Ambrikahn, Ground Shank, Tunneler Queen, Yaka Bears*

**Character Races**

Bora-Kai ..... 20

**Adventure!**

Rogue Planet ..... 22  
*The Wanderer in the Dark, The Sleepers, War in the Night, Carnival, When Worlds Collide*

Waylaid ..... 22

Crom's Return ..... 23

**Classified**

Frontier Classifieds ..... 24  
*A-1 Modular Drop-Homes, Dasharah's Pleasure Palace, Tordia, Bavor's Tracking Service, RiskCo, Cyber Optics, Vroy's Used Explorers, Pimp My Skimmer!, Dirty Deeds, Paranormal Investigators*

### ISSUE 3

**Frontier Feedback**

Questions and Answers ..... 1

**Technical Journal**

Gyrojet Weaponry ..... 2

Gyrojet Weapon Modifications ..... 3  
*Recoil compensator, Target Link, Targeting Scope*

Gyrojet Ammunition ..... 3  
*Doze Jetclip, Extended Jetclip, Fast Jetclip, Fragmentation Jetclip, Linked Jetclip, Poison Jetclip, Tangler Jetclip*

Gyrojet Weapon Tables ..... 4

**Star Systems**

Athor ..... 5  
*Athor I (Yast), Athor Ia (Exib), Athor Ib (Ime), Athor II, Athor III, Athor IV (Srah), Athor IVa (Jik), Athor IVb (Ezvoe), Athor IVc (Faan), Athor IVd (Spee)*

**Optional Rules**

Fleshing Out Your Character ..... 10

City Encounters ..... 13

**Archetypes**

Dralasite Spymaster ..... 16  
*Webspider, Master of Disguise, "Blob, James Blob", Counterspy*

Vrusk Visionary Ecologist ..... 18  
*Terraformer, Ecoterrorist, Planetologist*

**Equipment**

Miscellaneous Equipment ..... 20  
*Tag Tracker, Trace-Tags, Medtrace-Tags, Link-Bolts, Rebreather Mask, Thruster Pack*

Firearm Illustrations.....	22
<i>Gyrojet Pistol, Sonic Stunner, Automatic Pistol, Laser Pistol, Needler Pistol, Electro-Stunner, Automatic Rifle, Gyrojet Rifle, Laser Rifle, Sonic Disruptor, Needler Rifle, Sonic Devastator, Heavy Laser, Recoilless Rifle, Machine Gun</i>	
Zamira .....	24
<b>Locations</b>	
Crash Site .....	25
Raith Lair .....	26
<i>Cave Raith</i>	
<b>Adversaries</b>	
A Price On Your Head .....	27
<i>Rookiee Assassin, Professional Assassin, Elite Assassin</i>	
Bastian Kane, Elite Hit Man .....	28
Assassin Bot .....	29
<b>Character Races</b>	
Boon'sheh .....	30
<b>Adventure!</b>	
Sakleetown.....	32
Credit for a Flower, Mister? .....	32
A Heroic Start .....	32
<b>Classifieds</b>	
Frontier Classifieds .....	34
<i>Frontier Mutual, Missing Large Reward, Freighter Owner/Operator Wanted, Single Female Yazirian, Groko -, Xittic Industries, Custom Aircar Design, Vrodan's Subspace Radio Sales and Repairs, Shadow Shack, Veteran Mercenaries Needed!</i>	

## ISSUE 4

### Technical Journal

FTL Travel .....	1
<i>Hyperspace, Space Folding, Catapult, Jump Gates</i>	

### Star Systems

Scree Fron .....	4
<i>Scree Fron I (Hyn), Scree Fron II (Hakosoar), Scree Fron IIa (Inti), Scree Fron IIb (Infi), Scree Fron III (Halol), Scree Fron IV (Histran), Scree Fron IVa-IVg</i>	

### Optional Rules

Cinematic Martial Arts .....	9
Starting Gear .....	13
Species/Gender Ability Modifiers.....	14

### Equipment

Defensive Equipment: Helmets.....	15
<i>Unpowered Helmet, Universal Combat Helmet, Badlands Explorer's Helmet, Star Law Targeting Helmet, Sentry Helm, Yazirian Revolution Helmet</i>	
Miscellaneous Equipment.....	16
<i>Explorer Vest, Tactical Vest</i>	
Scatterguns .....	17
<i>Pump Action Scattergun, Autoloading Scattergun, Shattergun Shotclip</i>	
More Guns .....	19
<i>Sniper Rifle, K-Pulse Pistol</i>	
Robot Programs .....	20
<i>Medical, Technician, Robotics</i>	
Standard Robots	
<i>Medical Robots, Reconnaissance Robots, Repair Robots, Neotech HWK-2B, Wartech BEE-MK2</i>	
Melee Weapon Illustrations.....	22
<i>Sonic Sword, Sonic Knife, Knife, Sword, Electric Sword, Shock Glove, Stun Stick, Axe, Night Stick, Brass Knuckles, Vibro Knife, Club/Mace, Spear</i>	
<b>Locations</b>	
Outpost Refinery .....	23
Fountain Bar .....	24

Descriptions .....	25
--------------------	----

### Adversaries

Thugs, Mooks, and Goons .....	26
-------------------------------	----

### Archetypes

Human Xenomedical Specialist .....	29
<i>Surgeon Extraordinaire, Florence Knight Hawk, Hypocritical Hippocrates,</i>	
Yazirian Priest .....	31
<i>Wandering Holy Soul, Fatherly Redeemer, Righteous Defender,</i>	

### Character Races

Yinni .....	33
-------------	----

### Adventure!

Death Implant.....	36
Mystery of Starshine .....	36
The Usurper .....	36
Temple Raiders .....	36
The Great Hunt.....	37

### Classifieds

Frontier Classifieds.....	38
<i>Wanted Dead or Alive, Tordia -, - Squandered Youth - Dralosite Heavy Metal Cover Band, Ebban's Used Robot Shack, Alert!, Experienced Volunteer Target Wanted, Wartech MGK-1</i>	

## ISSUE 5

### Technical Journal

Don't Tango with the Tangler .....	1
Mine Kits .....	2
Tangler Gun .....	3

### Planet of Mystery

The UI-Mor.....	4
Annals of Xa Shrishen Traldor .....	6

### Optional Rules

Starport Layovers .....	8
Starflight: Starfighters in Alpha Dawn .....	9
<i>Mini-flyers, Personal Fighters, Military Fighters, Military Bombers, Jet Engine, Plasma Drive, After Burner, Dual-Action Piston, Proton Bolt and Launcher, Plasma Bomb, Redeye Missile, Guided Missile, Bomb Launcher, Crosshair Targeting, Target Tracker, Multi-Target Tracker, Target Discriminator, Starburst, System Packages I-V, Tables</i>	

### Equipment

Combat Armor.....	15
<i>Light Combat Armor, Medium Combat Armor, Heavy Combat Armor</i>	
Motion Tracker .....	16
Sentry Guns.....	17
Pulse Rifle.....	18
Yazirian Disc-Grenades.....	19
Inertia Wall.....	19
Blastaxe .....	20
New Equipment Tables .....	20

### Archetypes

Vrusk Pistolero .....	21
<i>Desperado, Slinger, Fated Mercenary</i>	

### Locations

Sathar Listening Post .....	25
City Tiles .....	26

### Adversaries

Xenomorphs (from the "Alien" movie saga).....	27
Creature Summary .....	34
<i>Alien Facehugger, Alien Warrior, Alien Queen</i>	

### Character Races

Vimh ..... 35

**Adventure!**

General Yan-Soon ..... 37

Double-Edged Sword Subplot ..... 37

Pirate Trust ..... 38

Sanctuary City ..... 38

**Classifieds**

Shameless Project Plug ..... 40

[www.starfrontiersman.com](http://www.starfrontiersman.com)

**ISSUE 6**

**Optional Rules**

Sentient Robots ..... 1

*Ellie, Squatto, Character Creation Summary*

**Spaceships**

The East Indiaman-Class Medium Freighter ..... 6

**Scenarios**

UPF Escort..... 12

*Pirate Fleet, UPF Escort*

**Star Systems**

The Prenglar System ..... 13

*Prenglar I (Aurora), Prenglar II, Prenglar III, Prenglar IV (Morgaine's World), Prenglar V (Gran Quivera), Prenglar IV, Prenglar VII, Prenglar VIII, Prenglar IX*

**Frontier History**

Sathar War I ..... 17

**Planet of Mystery**

The Arborean Race ..... 19

**Optional Rules**

Ability Score Limits..... 22

*Tables*

Shades of Motion in 3-D..... 23

*Sliding Scale Movement, Third Dimension of Flight*

**Equipment**

A few new pieces of gear ..... 26

*Displacement Screen, Sector 6 Smallarm, Detangler Harness, Holo-Field Scrambler,*

**Star Systems**

The Gruna-Garu System ..... 28

*Gruna-Garu I (Hargut), Gruna-Garu Ia (Trefrom), Gruna-Garu II {Vaeen}, Gruna-Garu III (Usen), Gruna-Garu IIIa (Khadz), Gruna-Garu IIIb (Oen), Gruna-Garu (Dhael), Gruna-Garu IV (Gnilgu)*

**Locations**

More tiles for use in city and jungle ..... 33

**Frontier Fiction**

Circle of Fate ..... 35

*Prologue, Chapter 1*

**Factions**

Sector 6..... 38

*The Omega Team, Research and Development Group, Sector 6 Chronocom, Sector 6 Smallarm*

Saran Wolfe NPC character sheet ..... 41

**Community News**

New Zeb's Guide Map ..... 42

Virtual Tabletop gaming ad..... 43

**Optional Rules**

Buying and Selling in the Frontier..... 44

*Haggling, Smuggling, Slavery, Junk Dealers, Bargaining Customs*

**Equipment**

Bonus Equipment Illustrations ..... 47

*Light Stunner Pistol, Blast Pistol, Semi-automatic Pistol, Gyrojet Wrist Rockets, Duraraft, Envirotent, Wide-Field Recorder, Survival Kit, Jumpboots, Visocom*

**Classifieds**

No more plugs! ..... 48

*Safe Adventure Awaits!, Why Die When Immortality is Yours for the Taking?, Explorers Wanted, I'm Tired of Waiting, Kakatak's Used Vehicles, Used Inertia Dampener, Work From Home, Wartech MGK-1 Recall!*

**ISSUE 7**

**Character Races**

On the Verge, Alternity Races ..... 1

Aleerin ..... 3

Fraal..... 5

Sesheyen ..... 7

*Stone Knife, Dart Bomb, Sliverbow*

T'sa ..... 9

*Microstunner*

Weren..... 11

*Rifled Musket, Weren Pepperbox, Weren Powder and Shot,*

**Creative Refereeing**

Structuring and Directing ..... 13

**Spawn of Zebulon**

Kurabanda..... 17

**Optional Rules**

Cinematic Action ..... 21

*Wounds and Morale, Cinematic Ammunition, Cinematic Henchemen*

**Equipment**

New tech for a dangerous time ..... 23

*EMP Field Grenades, Defense Rod, Personal Runabout, Tizzle Laser, Stun Grenades, Pion Engines, Bounty Shackles, Laser Auto Rifle, Electro-Magnetic Signal Stunner, Gel Airgun, Shocksuit, Skipflyer, Liberty-Class Patrol Gunship*

**Factions**

Turncoats of the Frontier ..... 31

**Frontier History**

The Tetrachs..... 35

**Locations**

Map Tiles..... 36

**Equipment**

Melee Tech ..... 37

*Electric Weapons, Sonic Weapons, Vibro Blades,*

**Community News**

Join the Revival..... 39

[www.starfrontiers.us](http://www.starfrontiers.us)

**Fiction**

Circle of Fate ..... 43

*Chapter 2*

**Classifieds**

Editor's Plea ..... 47

**Characters**

Yezha ..... 48

**Frontier Feedback**

Stellar Errata ..... 49

*Buying and Selling Clarifications, Starflight Q&A, Starflight Tables*

**Locations**

Random Land Map ..... 52

**Interviews**

Steve Winter Interview ..... 53

*Zebulon's Guide to Lunacy Tribute Cover*

**Locations**

Inspiration Zone, Images ..... 55

Solar Power Central ..... 56

**Frontier News**

Intergalactic Wireless..... 57

<i>124 Die in Freak Monorail Collision, Waste Haulers Want Ordinance Change Trashed, Yazirian Space Art LLC, Weeding Out Undocumented workers, Triple Bombing Deepens Terledrom Tensions, Armageddon Spacesuits Inc., Ryker's Rammers Claim Grav-Ball Title, Graphic Artists/Illustrators</i>	The Law and the Justice .....	35
<b>Spaceships</b>	<b>Optional Rules</b>	
UPF Fighters .....	Ablative Damage .....	45
<i>F-40C Vulcan, UPF-5 Shadow Star, RF-41 Seeker, S/RF-41 Surveillance Craft, I-76 Enforcer, SF-1 Dagger, F-20 Arrow, YT-100 "Phoenix", A-5 Knight Hawk</i>	<i>Ablative Damage Sheet</i>	
New Spaceship Technology .....	<b>Equipment</b>	
<i>Ion Drives, Plasma Drive, Deflector Screen, Albedo Shield, Pod Laser, Pod Laser Turret, Heavy Laser Cannon, Heavy Laser Battery, Ion Cannon, Ion Battery, FF Rockets, Striker Missile, Heavy Bomb/Rocket, Warhead Launcher Turret, Paramilitary Freighters, Streamlining, Armor Plating, Gravitics/Inertial Compensators, Universal Air Dock</i>	New gear for adventurers .....	49
<b>Scenarios</b>	<i>Autodoc, Laser Sniper Rifle, Photo-Voltaic Paint</i>	
Race Beyond the Frontier .....	<b>Spaceships</b>	
<i>UPF Charr'd Assault Scout, Streel One Assault Scout</i>	Eagle Transporter, Space 1999.....	51
<b>Mini-Module</b>	<b>Equipment</b>	
What's the Holdup?.....	Gauss Accelerators .....	52
<b>Puzzle</b>	<i>Gauss Assault Rifle, Gauss Sniper Rifle</i>	
What Is This?.....	<b>Vehicles</b>	
<b>Community News</b>	Robotic Steeds .....	53
Community Buzz .....	Manta Mini-Sub .....	54
<i>Races of the Frontier and Beyond, D100 Tables</i>	Bathyxplorer .....	54
<b>Classifieds</b>	<b>Character Races</b>	
Oh come on, you know you like these! .....	A Gorlian Thug?.....	55
<i>Tangler Tag!, Tired of Running, Mahg Mar Associates, Freeze for Life, Assault Scout Modifications, Brothers Four, Star Law, Sector Six Now Hiring</i>	<b>Creative Refereeing</b>	
<b>ISSUE 8</b>	Telling a Story.....	57
<b>Technical Journal</b>	<b>Character Races</b>	
Chronocom.....	Mechanon 2.0 .....	62
<i>Advanced Chronocom, Biocom, Signal Amplification Tower</i>	<b>Game Accessories</b>	
<b>Adventure!</b>	Knight Hawks Stat Cards .....	67
Crystal Catastrophe .....	<b>Classifieds</b>	
<b>Frontier History</b>	Oh come on, you know you like these! .....	78
Yazirian Clans .....	<i>Discovery Awaits, Robot Reprogramming, Truce, Robot Guards, Help Wanted, Precision Memory Removal, Frontiersman Heavy Pistol</i>	
<i>Hentz Lineages, Hargut Lineages, Athor Lineages, Hakosoar Lineages, Histran Lineages, Non-Yazirian World Lineages</i>	<b>ISSUE 9</b>	
<b>Planetary Brief</b>	<b>Optional Rules</b>	
Dinosaur Planet, Torrent.....	A skilled Frontier.....	1
<i>Siproot, Treemold, Armagor, Clamorbeak, Gainer, Hitchhiker Insect, Klastidon, Langet, Polyceratops, Pteribak, Retributisaur, Ripclaw, Snaggleback, Terrorsaur, Trapesaur, Tybor Monkey,</i>	<i>Agent PSA, Artist PSA, Linguist PSA, Military PSA, Pilot PSA, Scholar PSA, Scientist PSA, Scout PSA, Tech PSA</i>	
<b>Spawn of Zebulon</b>	<b>Equipment</b>	
The Mysterious Eorna!.....	Headset Computer .....	6
<b>Frontier Fiction</b>	<b>Humor</b>	
101 Uses for a Dead Robot .....	Norelco Speedrazor TZZ.A .....	6
<b>Factions</b>	<b>Optional Rules</b>	
Hovercycle Clubs of the Frontier .....	Artisan Skill (PSA) .....	7
<b>Characters</b>	<i>Appraise Art, Create Art, Create Masterpiece, Interpret Art, Restore Art</i>	
Eric "The Mouse" Stromm .....	<b>Gaming Resources</b>	
<b>Spaceships</b>	Sources for inspiration.....	10
Explorer-class Heavy Scout Craft.....	<b>Character Races</b>	
<i>Explorer-Class Heavy Scout, Expedition Shuttle Module, Detachable Cargo Bin</i>	Plants Named Scree .....	11
<b>Community News</b>	<b>Frontier Fiction</b>	
Write a Story .....	Destiny Run .....	13
	<b>Equipment</b>	
<b>Frontier Fiction</b>	Powered Battle Suits .....	16
	<i>Auto Recoilless Rifle, Machine Gun, Guided Missile Pack, Mortar Pack, "Stinger" Gyrojet Pack, Powered Battle Suit Ablative Damage Sheet, Vrusk Powered Battle Suit Ablative Damage Sheet</i>	
	It'll Ride Up With Wear .....	23
	<i>Shipsuit, Powered Skeinsuit, Articulated Combat Vehicle, M-11B, M-24 "Fire Angel", M-38 Spider Tank, Flak Armor</i>	
	<b>Vehicles</b>	
	Streel-Hyondow LR900V Ride Report.....	25
	<b>Equipment</b>	
	Shotguns.....	27
	<i>Ammo, Single Barrel Shotgun, Sawed-off Single Barrel Shotgun, Double Barrel Shotgun, Sawed Off Double Barrel</i>	

*Shotgun, Pump-Action Shotgun, TAC Pump-Action Shotgun, Combat Shotgun, Warmonger Shotgun*

**Spaceships**  
 The Jump Tug ..... 28

**Frontier Fiction**  
 Clash By Night ..... 32

**Optional Rules**  
 Adventure Pets ..... 41  
*Che, Fazer Wolf, Gooligott, Kakra, Lanka, Loper, Mauler Hound, Meket, Pinar's Ant, Sand Eel, Zeridactyl, Pet Care Supplies, Collar, Licensing, Harness, Saddle, Parka, Talon Guard, Animal Trainer PSA*

**Game Report**  
 Basically Speaking..... 46

**Locations**  
 Isolated Outpost ..... 51

**Classifieds**  
 Your ad here! ..... 52  
*Prime 1 Mercs, OE Careers, Bionical Engineering and the Robotic Prosthetic, Truce Accepted*

**ISSUE 10**

**Frontier Feedback**  
 Letters to the Editor ..... 1  
*Powered Battle Suits Clarifications*

**Community News**  
 NPC Ablative Damage Sheet Adoption..... 2

**Creative Refereeing**  
 Abstract Refereeing ..... 3

**Factions**  
 Mercenaries of the UPF Private Sector..... 5

**Game Report**  
 Tales from the Falcon ..... 9

**Humor**  
 Dralasite Facts ..... 12

**Optional Rules**  
 Spacer Skills Revisited ..... 13

**Equipment**  
 New Frontier Weapons ..... 14  
*Heavy Gyrojet Rifle, Gyrojet Stablized Rocket, Gyrojet Scope, Albedo Grenade, Laser Grenade*

**Frontier Fiction**  
 Last of the Breed - Part I ..... 17

**Game Accessories**  
 NPC Character Cards ..... 24  
 NPC Ablative Damage Character Sheets ..... 25

**Classifieds**  
 There's mischief afoot in the galaxy!..... 26  
*Wartech Industries Heavy Gyrojet Rifle, End Game, Work From Home, RiskCo High-Risk Paramilitary Operations, Veteran Mercenaries Needed!*

**ISSUE 11**

**Optional Rules**  
 Star Frontiers Without Subspace Radios ..... 1  
 Military Ship Design..... 5

**Gaming Resources**  
 Sources For Miniatures ..... 4

**Frontier History**  
 UPF Order of Battle ..... 8

**Equipment**  
 FTL Torpedos..... 10

**Planetary Brief**  
 Minotaur in the Theseus System ..... 11

**Spaceships**

TSSS Dart ..... 13  
 RT-3100 Merchant Scout ..... 16

**Optional Rules**  
 Vector Movement ..... 18  
 Acceleration, Movement Sequence,

**Frontier Fiction**  
 Last of the Breed, Part II..... 21

**Game Accessories**  
 KH Ship Sheet ..... 25

**Classifieds**  
 Last words and sincere apologies ..... 26  
*Prime 1 Mercs Apology, Estate Sale, Join the Star Fighter Corps!*

**ISSUE 12**

**Frontier Feedback**  
 Alpha Dawn Remastered Errata..... 1

**Frontier Fiction**  
 TIME BOMB ..... 6  
 Sathar Briefing Report ..... 34  
 The Motivation of the Sathar..... 36

**Optional Rules**  
 The Versatile Ion Drive ..... 38

**Character Races**  
 The Industrious Ifshnit..... 42  
 The Core Four ..... 48

**Planetary Brief**  
 Laco in Dixon's Star ..... 45

**Frontier History**  
 Ground & Hover Cycle History ..... 47

**New Equipment**  
 Yazirian Triple Barrel Gyrojet ..... 48

**Character Races**  
 The Core Four - Part 1 ..... 50

**Characters**  
 CHARACTERS-R-US ..... 54

**Inspiration Zone**  
 Sathar Adventure ..... 57  
 The Keep It Rolling Story ..... 58

**Optional Rules**  
 Characters With Class ..... 62

**Star Frontiersman**  
 Contents of Issue 1-12..... 72

**Classifieds**  
*Battle Rage and Coke!, Shadow Shack Choppers, Frontier Zoo, Holo-You, Parriah Eliminations, Missing Cybot*

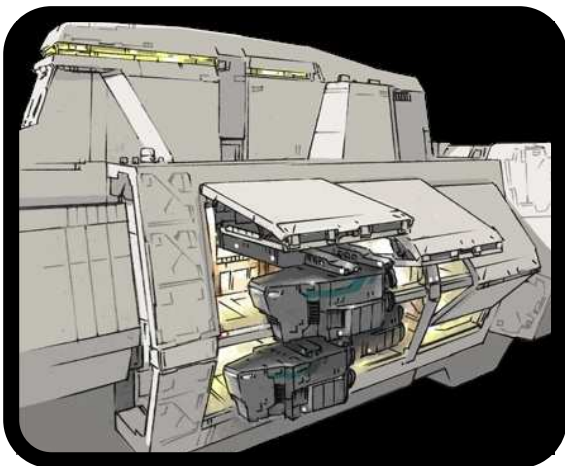

## Subject Index

### Articles (by Type)

#### Adventure!

*Credit for a Flower, Mister?*, #3-p32  
*Crom's Return*, #2-p23  
*Crystal Catastrophe*, #8-p6  
*Death Implant*, #4-p36  
*Double-Edged Sword Subplot*, #5-p37  
*Fall of Tomorrow, the*, #1-p16  
*General Yan-Soon*, #5-p37  
*Great Hunt, the*, #4-p37  
*Heroic Start, a* #3-p32  
*Keep It Rolling Story*, #12-p58  
*Long Road to Rhald'ran, the* #1-p16  
*Mystery of Starshine*, #4-p36  
*Pirate Trust*, #5-p38  
*Rogue Planet*, #2-p22  
*Sakleatown*, #3-p32  
*Sanctuary City*, #5-p38  
*Sathar Adventure*, #12-p57  
*Usurper, the* #4-p36  
*Temple Raiders*, #4-p36  
*Waylaid*, #2-p22  
*Sathar Adventure*, #12-p

#### Adversaries

*A Price On Your Head*, #3-p27  
 Rookiee Assassin, #3-p27  
 Professional Assassin, #3-p27  
 Elite Assassin, #3-p27  
 Bastian Kane, Elite Hit Man, #3-p28  
 Assassin Bot, #4-p29  
*Creatures of Hentz*, #2-p18  
 Ambrikahn, #2-p18  
 Ground Shank, #2-p18  
 Tunneler Queen, #2-p19  
 Yaka Bears, #2-p19  
*Motivation of the Sathar, the*, #12-p36  
*Sathar Briefing Report*, #12-p35  
*Standard Security Robots*, #1-p12  
 Alpha-Class Security Robot, #1-p12  
 Beta-Class Security Robot, #1-p13  
 Gamma-Class Security Robot, #1-p13  
*Thugs, Mooks, and Goons*, #4-p26  
*Turncoats of the Frontier*, #7-p31  
*Xenomorphs, Movie: Aliens*, #5-p27  
 Alien Facehugger, #5-p34  
 Alien Warrior, #5-p34  
 Alien Queen, #5-p34

#### Archetypes

*Dralasite Martial Artist*, #1-p6  
*Dralasite Spymaster*, #3-p16  
*Human Systems Technician*, #2-p10  
*Human Xenomedical Specialist*, #4-p29  
*Vrusk Pistolero*, #5-p21  
*Vrusk Smuggler*, #1-p8  
*Vrusk Visionary Ecologist*, #3-p18  
*Yazirian Cyber Cop*, #2-p12  
*Yazirian Priest*, #4-p31

#### Characters

Yezha, #7-p48  
 Eric "The Mouse" Stromm, #8-p28  
 Characters R Us, #12, p54

### Character Races

*Bora-Kai*, #2-p20  
*Boon'sheh*, #3-p30  
*Dralasites*, #12-p50  
*Gorlians*, #8-p55  
*Humans*, #12-p52  
*Ifshnit*, #12-p42  
*Mechanon 2.0*, #8-p62  
*Nagana*, #1-p10  
*On the Verge, Alternity Races*, #7-p1  
 Aleerin, #7-p3  
 Fraal, #7-p5  
 Sesheyan, #7-p7  
 T'sa, #7-p9  
 Weren, #7-p11  
*Scree, Plants Named*, #9-p11  
*Vimh*, #5-p35  
*Yinni*, #4-p33  
 (See *Planet of Mystery, Voltturnus*)

### Community News

*Community Buzz*, #7-p73  
*Join the Revival*, #7-p39  
*New Zeb's Guide Map*, #6-p42  
*NPC Ablative Damage Sheet Adoption*, #10-p2  
*Virtual Tabletop gaming*, #6-p43

### Core Races

*The Core Four Part 1, Dralosite, Human*, #12-p48

### Creative Refereeing

*Abstract Refereeing*, #10-p3  
*Structuring and Directing*, #7-p13  
*Telling a Story*, #8-p57

### Equipment

*Albedo Grenade*, #10-p15  
*Autodoc*, #8-p51  
*Autodock*, #8-p49  
*Blast Axe*, #5-p20  
*Blastpistol*, #1-p1  
*Bonus Equipment Illustrations*, #6-p47  
*Bounty Shackles*, #7-p26  
*Chronocoms*, #8-p1  
*CKA Fast Drawing Holster*, #2-p14  
*Combat Armor*, #5-p15  
*Computers*, #2-p1  
*Computers, New Items*, #2-p3  
*Defense Rod*, #7-p23  
*DefensiveHelmets*, #4-p15  
*Detangler Harness*, #6-p27  
*Displacement Screen*, #6-p26  
*Duraraft*, #1-p3  
*Electro-Magnetic Signal Stunner*, #7-p27  
*EMP Field Grenades*, #7-p23  
*Envirotent*, #1-p3  
*Explorer Vest*, #4-p16  
*Extended Bulletclips*, #2-p14  
*Firearm Illustrations*, #3-p22  
*Flak Armor*, #9-p  
*FTL Torpedos*, #11-p10  
*Gauss Accelerators*, #8-p52  
*Gauss Assault Rifle*, #8-p52  
*Gauss Sniper Rifle*, #8-p52  
*Gel Airgun*, #7-p28  
*Gyrojet Ammunition*, #3-p3  
*Gyrojet Mods (Recoil, Target Link, Target Scope)*, #3-p2

Gyrojet Scope, #10-p14  
 Gyrojet Stabilized Rocket, #10-p14  
 Gyrojet Weaponry, #3-p2  
 Gyrojet Wristrockets, #1-p2  
 Headset Computer, #9-p6  
 Heavy Gyrojet Rifle, #10-p14  
 Holo-Field Scrambler, #6-p27  
 Inertia Wall, #5-p19  
 It'll Ride Up With Wear, #9-p23  
 Jumpboots, #1-p3  
 K-Pulse Pistol, #4-p19  
 Laser Auto Rifle, #7-p27  
 Laser Grenade, #10-p16  
 Laser Sniper Rifle, #8-p50  
 Laser Sniper Rifle, #8-p52  
 Light Stunner Pistol, #1-p1  
 Link Bolts, #3-p21  
 Medtrace-Tags, #3-p20  
 Melee Tech, #7-p37  
 Melee Weapon Illustrations, #4-p22  
 Mine Kits, #5-p2  
 Miscellaneous Equipment, #4-p16  
 Miscellany Equipment, #3-p20  
 More Guns, #4-p19  
 Motion Tracker, #5-p16  
 Photo-Voltaic Paint #8-p53  
 Photo-Voltaic Plant, #8-p50  
 Pion Engines, #7-p26  
 Powered Battle Suits, #9-p16  
 Powered Skeinsuit, #9-p23  
 Projectiles, #2-p14  
 Pulse Rifle, #5-p18  
 Rebreather Mask, #3-p21  
 Robot Programs, #4-p20  
 Scatterguns, #4-p17  
 Sector 6 Smallarm, #6-p26  
 Security Skeinsuit, #1-p2  
 Semi-automatic Pistol, #1-p2  
 Sentry Guns, #5-p17  
 Shipsuit, #9-p23  
 Shocksuit, #7-p28  
 Shotguns, Various, #9-p27  
 Sniper Rifle, #4-p19  
 Stealthskin, #1-p2  
 Stun Grenades, #7-p25  
 Survival Kit, #1-p3  
 Tactical Vest, #3-p16  
 Tag Tracker, #3-p20  
 Trace-Tags, #3-p20  
 Thruster Pack, #3-p21  
 Tangler Grenades, #5-p1  
 Tangler Gun, #5-p3  
 Tizzle Lazer, #7-p25  
 Vehicles, #2-p15  
 Visocom, #1-p3  
 Wide Field Recorder, #1-p3  
 Yazirian Disc-Grenades, #5-p19  
 Yazirian Triple Barrel Gyrojet Rifle, #12-p48  
 Zamira, #3-p24

### **Factions**

Hovercycle Clubs of the Frontier, #8-p25  
 Known 'cycle gangs of the Frontier, #8-p25  
 Mercenaries of the UPF Private Sector, #10-p5  
 Saran Wolfe NPC character sheet, #6-p41  
 Sector 6, #6-p38

Turncoats of the Frontier, #7-p31

### **Frontier Classifieds**

Editor's Plea, #7-p47

Classifieds, #2-p24, #3-p34, #4-38, #5-p40, #6-p48, #7-p73, #8-p78, #12-p71

### **Frontier Feedback**

Alpha Dawn Remastered Errata, #12-p1

Powered Battle Suits Clarifications, #10-p1

Questions and Answers, #3-p1

Stellar Errata, #7-p49

### **Frontier Fiction**

101 Uses for a Dead Robot, #8-p23

Circle of Fate, Chapter 1, #6-p35

Circle of Fate, Chapter 2, #7-p43

Clash By Night, #9-p32

Destiny Run, #9-p13

Keep It Rolling Story, #12-p58

Last of the Breed - Part I, #10-p17

Last of the Breed - Part II, #11-p21

Law and the Justice, the, #8-p35

Tetrachs, the, #6-p35

Time Bomb, #12-p6

### **Frontier History**

Ground & Hover Cycle History, #12-p47

Hovercycle Clubs of the Frontier, #8-p25

Sathar War I, #6-p17

Tetrachs, the, #7-p35

UPF Order of Battle, #11-p8

Yazirian Clans, #8-p8

### **Frontier News**

Intergalactic Wireless, #7-p57

### **Game Accessories**

Knight Hawks game cards, #8-p67

Knight Hawks Ship Roster, #11-p25

NPC Ablative Damage Sheets, #10-p25

NPC Character Sheets, #10-p24

### **Game Report**

Basically Speaking, #9-p46

Tales from the Falcon, #10-p9

### **Gaming Resources**

Sources for inspiration, #9-p10

Sources for Miniatures, #11-p 4

### **Humor**

Dralasite Facts, #10-p12

Norelco Speedrazor TZZ.A, #9-p6

### **Interviews**

Steve Winter, #7-p53

### **Locations**

City Tiles, #5-p26

Crash Site, #3-p25

Descriptions, #4-p25

Evergloom, moon prison of Triad, #1-p5

Fountain Bar, #4-p24

Inspiration Zone, #6-p55

Isolated Outpost, #9-p51

Map Tiles at chit scale, #7-p36

Map Tiles for your games, #6-p33

Outpost Refinery, #4-p23

Raith Lair, #3-p26

Random Land Map, #7-p52

Referee's Maps, #7-p52

Rockroost Mining Colony, #2-p17

Sathar Listening Post, #5-p25

Solar Power Central, #7-p56

### **Mini-Module**



*What's the Holdup*, #7-p69

### Optional Rules

*Skilled Frontier, A*, #9-p1

*Agent PSA, Artist PSA, Linguist PSA, Military PSA, Pilot PSA, Scholar PSA, Scientist PSA, Scout PSA, Tech PSA*

*Ability Score Limits*, #6-p22

*Ablative Damage*, #8-p45

*Adventure Pets*, #9-p41

*Artisan Skill (PSA)*, #9-p7

*Buying and Selling in the Frontier*, #6-p44

*Characters With Class*, #12-p62

*Cinematic Action*, #6-p21

*Cinematic Martial Arts*, #4-p9

*City Encounters*, #3-p13

*Experience Points*, #1-p14

*Fleshing Out Your Character*, #3-p10

*Getting Drunk!*, #2-p9

*Hit Location*, #2-p7

*Ion Drive, The Versatile*, #12-p38

*Melee Tech*, #7-p37

*Military Ship Design*, #11-p 5

*Sentient Robots*, #6-p1

*Shades of Motion in 3-D*, #6-p23

*Skills*, #1-p15

*Spacer Skills Revisited*, #10-p13

*Species/Gender Ability Modifiers*, #4-p14

*Star Frontiers Without Subspace Radios*, #11-p1

*Starflight: Starfighters in Alpha Dawn*, #5-p9

*Starport Layovers*, #5-p8

*Starting Gear*, #4-p13

*Vector Movement*, #11-p18

### Planet of Mystery, Voltarnus

*Annals of Xa Shrishen Traldor*, #5-p6

*Arborean Race, the*, #6-p19

*Spawn of Zebulon, Eorna*, #8-p19

*Spawn of Zebulon, Kurabanda*, #6-p17

*Ul-Mor, the*, #5-p4

### Planetary Brief

*Dinosaur Planet, Torrent*, #8-p11

*Gruna-Garu System, the*, #6-p28

*Laco in Dixon's Star*, #12-p45

*Minotaur in the Theseus System*, #11-p 11

*Prenklar System, the*, #6-p13

### Puzzle

*What Is This?*, #7-p72

### Scenarios

*Race Beyond the Frontier*, #7-p67

*UPF Escort*, #6-p12

### Spaceships

*Eagle Transporter*, #8-p51

*East Indiaman Medium Freighter, the*, #6-p6

*Explorer-class Heavy Scout*, #8-p29

*Expedition Shuttle*, #8-p33

*Jump Tug, the*, #9-p28

*Liberty-Class Patrol Gunship*, #7-p30

*New Starship Technology*, #7-p64

*RT-3100 Merchant Scout*, #11-p16

*TSSS Dart*, #11-p13

*UPF Fighters*, #7-p61

*F-40C Vulcan*, #7-p61

*UPF-5 Shadow Star*, #7-p61

*RF-41 Seeker*, #7-p62

*I-76 Enforcer*, #7-p62

*SF-1 Dagger*, #7-p63

*F-20 Arrow*, #7-p63

*YT-100 "Phoenix"*, #7-p64

*A-5 Knight Hawk*, #7-p64

### Spaceship Technology

*FTL Torpedos*, #11-p10

*New Starship Technology*, #7p-65-65

*Ion Drives*

*Plasma Drive*

*Deflector Screen*

*Albedo Shield*

*Pod Laser*

*Pod Laser Turret*

*Heavy Laser Cannon*

*Heavy Laser Battery*

*Ion Cannon*

*Ion Battery*

*FF Rockets*

*Striker Missile*

*Heavy Bomb/Rocket*

*Warhead Launcher Turret*

*Streamlining*

*Armor Plating*

*Gravitics/Inertial*

*Compensators, Universal Air Dock*

### Star Systems

*Araks*, #2-p4

*Athor*, #3-p5

*Gruna-Garu System, the*, #6-p28

*Hentz*, #2-p5

*Scree Fron*, #4-p4

### Technical Journal

*Chronocoms*, #8-p1

*Computers*, #2-p1

*Don't Tango with the Tangler*, #5-p1

*FTL Travel*, #4-p1

*Gyrojet Weaponry*, #3-p2

*Mine Kits*, #5-p2

*New Items*, #2-p3

*Tangler Gun*, #5-p3

### Vehicles

*Articulated Combat Vehicle*, #9-p24

*M-11B, M-24 "Fire Angel"*

*M-38 Spider Tank*

*Bathyxplorer*, #8-p54

*Infiltrator*, #2-p14

*Manta Mini-Sub*, #8-p54

*Personal Runabout*, #7-p24

*Robotic Steeds*, #8-p53

*Skipflyer*, #7-p29

*Streel-Hyondow LR900V Ride Report*, #9-p25

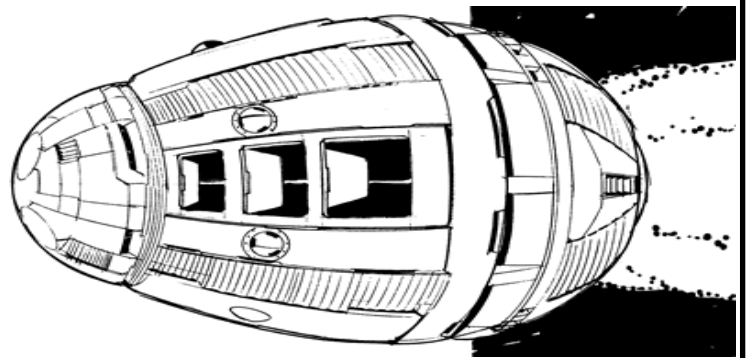

# CLASSIFIEDS



**BATTLE RAGE**  
What happens when a vending machine stiffs a gazerian.

**Bilko's Vending**  
Specializing in Battle-Rage-Proof Machines!  
Subspace Relay #773430287282847474

Slick, sick, and anything but plain. Get it done somewhere else and you can take the blame!



CHOPPIN' AWAY AT PORT LAVAKOS. VOLTURNUS (ZEBULON)

Subspace Relay #98919383837522294

Thought you had me, eh Tordia?

Well... I guess I got a little surprise.

Subspace Relay #you-know-who

-Groko

Holo-YOU  
Holo-YOU

Why be you when you can be **NEW!**  
Holo-YOU specializes in personal holo-field technology transforming the mundane you into the **NEW!**

Subspace Relay #82873238382982323

## Frontier Zoo

Bring the family to the first ever traveling Zoo!

- Meet the shrieking sky shrikes!
- The Travelling Yinni Band!
- The only known captive gwerrah!
- Juggling Dralasites!
- Flying Yazirians from Hakosoar!

...and much much more!  
Ticket@ Subspace Relay #8374382892737373

**RECALL**  
(Sort of Enterprises)

Tangler Guns are \*not\* toys and should never be used by beings 20 years or younger.

Many of these guns are frequently found at lazer-tag entertainment establishments. Shame on you!

Parriah Eliminations -- When the "other guys" fail!  
o Insurrections  
o Terrorists  
o Icewars

When the other guys fail, when you absolutely positively have to get rid of them. Call Parriah @ 089533994268593390054



Photo of Alph Team; Fuzzy, Pournell and Parriah (with this trademark 14mm Double Express)

### MISSING CYBOT

Answers to "DipSwitch".

Know to **deface robots** with the following examples;

- Twit
- Kick Me
- Short Circuit Me
- Recycle Me
- Your kidding?
- I can't add 01 and 10
- Numb Nut
- Bot Dee & Bot Dum
- Scrape Me

Subspace Relay #3473847373734774

\*\*\* REWARD \*\*\*