

ISSUE

7

November
2007

STAR FRONTIERSMAN

Magazine

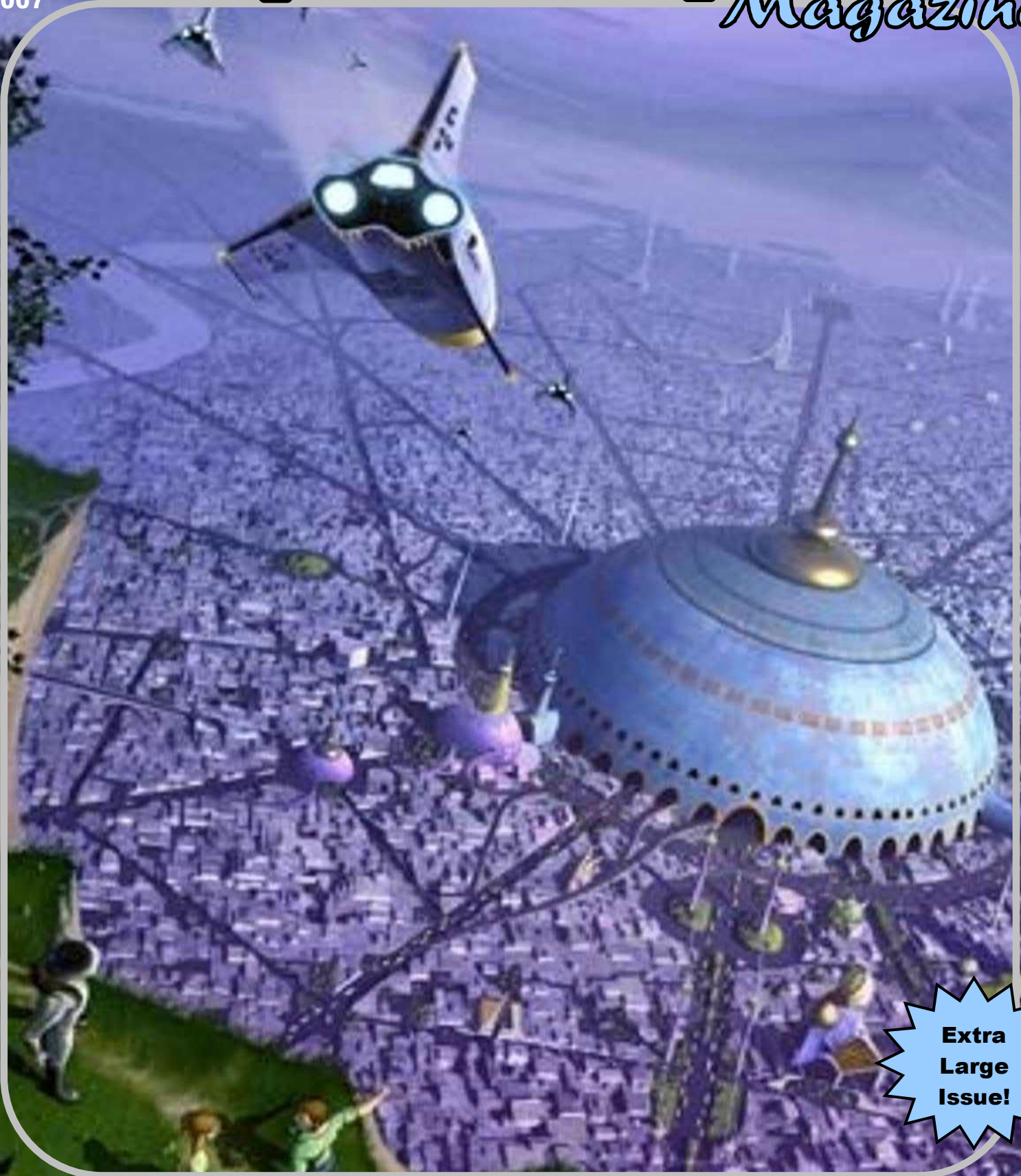

Extra
Large
Issue!

Join the Star Frontiers Revival!

Art By Mark Garlick

STAR FRONTIERSMAN

Magazine

ON THE VERGE

Alternity meets Frontier, by Andrew Modro1

CREATIVE REFEREEING

Insight into good GM practices, by Brian Conway 13

SPAWN OF ZEBULON

The mysterious Kurabanda, by R. Kevin Smoot 17

CINEMATIC ACTION

Handling action like the movies, by Andrew Modro 21

EQUIPMENT

New tech for a dangerous time, various submitters..... 23

TURNCOATS OF THE FRONTIER

Who's spying for the Sathar, by Di Mo..... 31

THE TETRACHS

A riddle lost to time, by C.J. Williams..... 35

MAP TILES

Tiles for your games, at chit scale, by Bill Logan 36

MELEE TECH

Buid your own sonic halberd, by Bill Logan..... 37

JOIN THE REVIVAL

Collaborating on our favorite hobby..... 39

CIRCLE OF FATE

Chapter 2, by Auden Reiter..... 43

STELLAR ERRATA

Corrections and examples, C.J. Williams 49

REFEREE'S MAPS

For when you're making it up on the fly, by Bill Logan..... 52

INTERVIEWS

C.J. Williams corners Steve Winter..... 53

INSPIRATION ZONE

To help you with your imagination lull 55

BONUS REFEREE'S MAP

Solar Power Central, by Adam Brown 56

INTER-GALACTIC WIRELESS

Frontier News, by author John Mark Simpson 57

LFP FIGHTERS

Tearing up the stars, by Shadow Shack 61

ADVENTURE!

Race Beyond the Frontier, by Larry Moore..... 67

What's the Holdup, by Michael O'Dell..... 69

COMMUNITY BUZZ

A chance for YOU to talk 73

CLASSIFIEDS

Oh come on, you know you like these!Back cover

On the cover: Mark Garlick is an exceptional artist, and graciously gave us permission to use his artwork for the covers. You can be sure to find more of his imaginative pieces on future covers. Check out a sample of his works at <http://www.markgarlick.com>.

WHAT A LONG FEW MONTHS!

First I had family matters that kept me from the webzine... then I had a hard drive crash (and I had nothing backed up! So much is lost!)... then I decided to concentrate on finishing up the new website prior to release of this issue (I hope everyone who downloads this checks it out and makes an account!).

But now it's finally done, and I think this is an amazing issue. I actually held back some content this time (I have a start on Issue 8 already!), and still have 75 pages of Star Frontiers goodness to share! The crashed hard drive meant I had to start from scratch on the page layout... so while I was at it I redesigned the cover page template as well.

The new website (check it out on page 39) should prove to be a goldmine in collaboration, helping the Star Frontiers revival to propel itself forward with strength and quality. Times are looking good for the future of this game.

My son's midget league football team made it to the semi-finals with him steering them as Quarterback. My daughter's dance classes are postponed until next season. My mother-in-law's broken ankle is healing (and she'll be returning home soon!)... which means time is opening up for me to fine-tune the new site and to.... you guessed it... play Star Frontiers!

I apologize for the three month hiatus, and I promise that the Star Frontiers revival is not dying to embers, but sparking a fresh new blaze that shall not be quenched. So grab your sonic swords and raise them high... and um... um...

Okay that was really nerdy... I'll stop that.

Thank you for your submissions, and thank you for your support by downloading this PDF. There is no profit being made by me or anyone else here, so if you like something or have some criticism – contact me or the author of the article in question and let them know. It helps us to get feedback!

Game On!
Bill Logan
Referee@StarFrontiersman.com

ON THE VERGE

By Andrew Modro

ALTERNITY ALIEN SPECIES

For use in STAR FRONTIERS Alpha Dawn games.

In 2004, Wizards of the Coast published the d20 Future supplement for their d20 Modern role-playing game. Alongside the resurrected aliens of the Frontier, d20 Future also brought back to life the aliens of Alternity, TSR's short-lived science fiction game.

Inspired by the presentation of all these wonderful alien species side-by-side, this article presents the aliens of Alternity in STAR FRONTIERS Alpha Dawn rules format. Now, for the first time, you can have fraal rubbing shoulders with vrusk, or t'sa and dralasites sharing jokes, in your Alpha Dawn campaigns!

The conversion write-ups here do hold some few differences from both the Alternity and d20 Future write-ups. The special abilities of each species did not translate perfectly, and had to be adapted to the peculiarities of the STAR FRONTIERS system's mechanics. They have been balanced against the Alpha Dawn species as well as could be managed.

OPTIONS FOR USE

These are some possible options for including the Alternity aliens in your Alpha Dawn games. These are not the only ways for these species to meet, but hopefully they will provide you with inspiration.

• GRAND FRONTIER

The easiest method to incorporate the new species into your games is to say that they have always been there, and begin a new campaign with a much-expanded Frontier population. How the five new species are distributed through the worlds of the Frontier is for each individual referee to decide.

• ENCOUNTERING THE VERGE

Another easy method is to populate another region of space with these five new species, and place that region beyond the borders of the known Frontier. In the Alternity Star*Drive campaign, most of the action takes place in just such a setting. What will happen when these two multispecies societies come into contact? Have the citizens of the Verge encountered the Sathar? Do they face any other threats?

• VOYAGERS

Building on one of the "Rogue Planet" adventure seeds from Star Frontiersman issue #02 (March 2007), in this idea, the Alternity aliens are cryogenically frozen passengers -- or prisoners -- in the heart of a rogue planet that has drifted through interstellar space for thousands of years or more. How will these ancient newcomers adapt to life in a brand new region of the galaxy?

• AGENTS OF CHAOS

What if these new aliens seemed friendly when first encountered, but were eventually revealed to be agents for the Sathar, their entire civilization conquered by the evil worms and aimed at the Federation and the Frontier? Could they be saved, or will it be total war?

MIXING AND MINGLING

The write-ups for each species in this article are presented in a generic way, enabling referees to use them in any manner they wish. However, this presentation leaves out the attitudes that the Alternity species might have of the Alpha Dawn aliens. If the referee wishes to run a mixed campaign, these attitudes may develop in this way:

• ALEERINS

The general good cheer of the mechalus endears them to the dralasites, and their understanding of ordered systems gives them a point of contact



EDITOR'S NOTE

This article is inspired by the works of Bill Slavicsek and Richard Baker, along with the rest of the talented staff from TSR (now owned by Wizards of the Coast, inc.) who gave us the Alternity game system. The artwork used in this article is by RK Post, reproduced from the Alternity Player's Handbook (1998). Neither the author of this article nor the editor of this webzine claim credit for the creativity of these individuals. Anyone who enjoys use of this article may find the Alternity game, or the d20 Future conversion of it, to his liking.



with the vrusk. The yazirians look on the alerins with some suspicion, not quite trusting a species which would fuse itself so with machinery. Alerins bridge the gap between the reserved fraal and the almost childlike t'sa with both their social customs and their advanced technology, but are somewhat wary of the more animalistic instincts of the sesheyans and weren, though they will give these latter two species the benefit of the doubt every time, knowing that technological development and intelligence are not the same thing.

• FRAAL

The best friends the fraal could have are the socially ordered vrusk and the technologically-adept alerins and t'sa. These two species together will make astonishing scientific advances in the future. Fraal spend as little time as possible around yazirians, and are confused -- but intrigued -- by the strange nature of the dralasites. They likewise do not socialize by choice with the weren, but they believe they can "save" the sesheyans by guiding their primitive culture toward a more controlled mindset. Though fraal respect the t'sa drive and ability, they have a distaste for the t'sa's natural energy level.

• SESHEYANS

The primitive hunters find the most in common with the yazirians and weren; their ability to truly fly makes the yazirians a little jealous, and they don't quite understand why the weren would bother with even black powder weapons, however. The dralasites make the sesheyans a little nervous, but the blobs' open and soothing demeanor can smooth over this difficulty. Sesheyans feel comfortable around the vrusk, who are also quite differently-shaped from the more humanoid species, but do not like their hive-like social customs. Sesheyans find the t'sa both cute and annoying, depending on how badly the little lizards are getting on their nerves.

• T'SA

The t'sa get along quite well with the vrusk, who are patient with the t'sa's jittery ways, and are fond of the dralasites for their engaging demeanor. They regard the yazirians as a bit dangerous, because of their ability to fly into a berserk rage in battle. T'sa have shared many scientific secrets with the fraal, but feel the fraal to be too cold; likewise, the t'sa and alerins have

also shared advances, but the t'sa fear the alerins may eventually cast aside their emotions entirely and become just like the fraal. T'sa like to hang around with the weren, especially when in danger, relying on the giants' size, strength and martial prowess for protection. The t'sa see something of themselves from long ago in the sesheyans and would like to encourage the sesheyans to open up their minds to modern technology.

• WEREN

The weren regard the yazirians as brothers in spirit, a fellow warrior culture descended from mighty hunters, though a bit beholden to more modern technology. They regard the sesheyans as a potential third to this group of species, and some weren are beginning to study the sesheyans' philosophies of natural balance and near-atavistic self-reliance. The weren have little care for the studied patience of the vrusk and fraal, especially in the latter's reliance on high technology. The weren respect that the t'sa have not lost their passion to their advancing technological knowledge, and enjoy the dralasites' strange sense of humor. They regard the alerins' focus on positive emotions as imbalanced, unhealthy and forced, feeling that one must experience passions of all kinds to be whole.

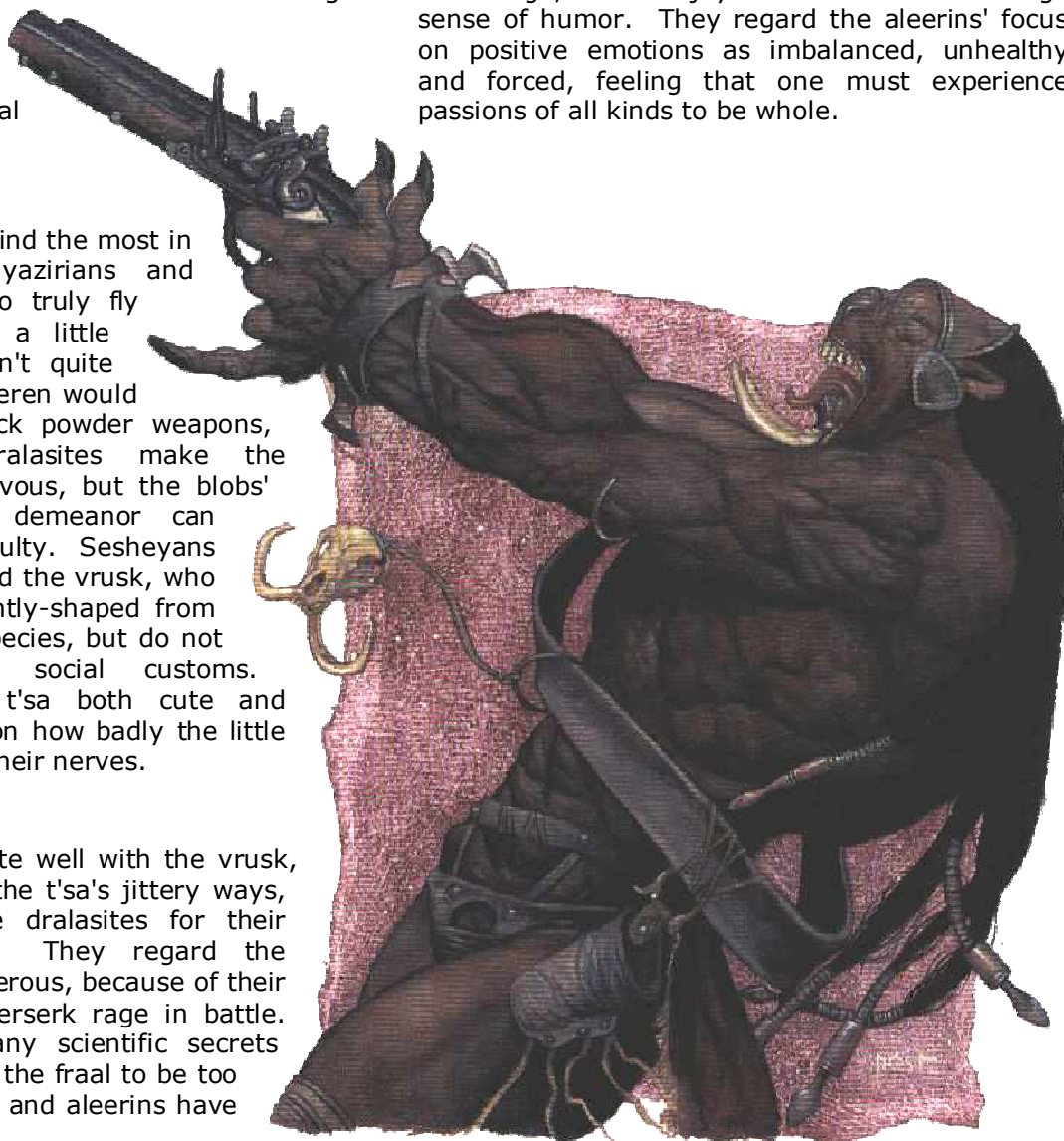

ALEERIN

PHYSICAL STRUCTURE

Aleerin size and shape is so remarkably human-like that aleerins can easily be mistaken for humans at a distance or in poorly-lit conditions. The differences between aleerins and humans become quite evident close-up, however.

The aleerins are a cyborg race, combining organic life with technology to create a new whole. Circuits run across their skin, their hair is a mass of wires, and their skeletons and musculature have been enhanced with reinforcements.

The organic skin of aleerins runs a gamut of colors from shades of blue and gray to orange and bronze. Their eyes are universally turquoise with no irises or pupils, however, lending their gaze a mechanical aspect.

Aleerin children are formed of reproductive cells taken from a male and female parent, but are grown in special tanks which implant the cybernetic enhancements endemic to all aleerins. The aleerins as a species have moved past "natural" reproduction, but still carry its evolutionary legacy in their sexual dimorphism.

SENSES

Aleerins have senses comparable to humans. Their binocular vision is in the same color range as humans, and they hear similar frequencies of sound. Like humans, their sense of smell is less well-developed than their sight and hearing.

SPEECH

Aleerins have a vocal ability of the same type as humans and many other sentient species, utilizing lungs and a larynx, though these organs are partially mechanical. Aleerins are capable of speaking any human language, and their own native tongue is easily reproducible by humans and those others who can also speak human languages. Aleerin voices do differ from human voices in having a somewhat synthesized quality.

SOCIETY & CUSTOMS

The differences between aleerins and humans are most apparent in their behavior and social customs. Where humans are often creatures of passion, aleerins are known for their ordered thoughts. While still deeply emotional beings, aleerins are capable of suppressing those emotions in times of stress to allow them to think clearly.

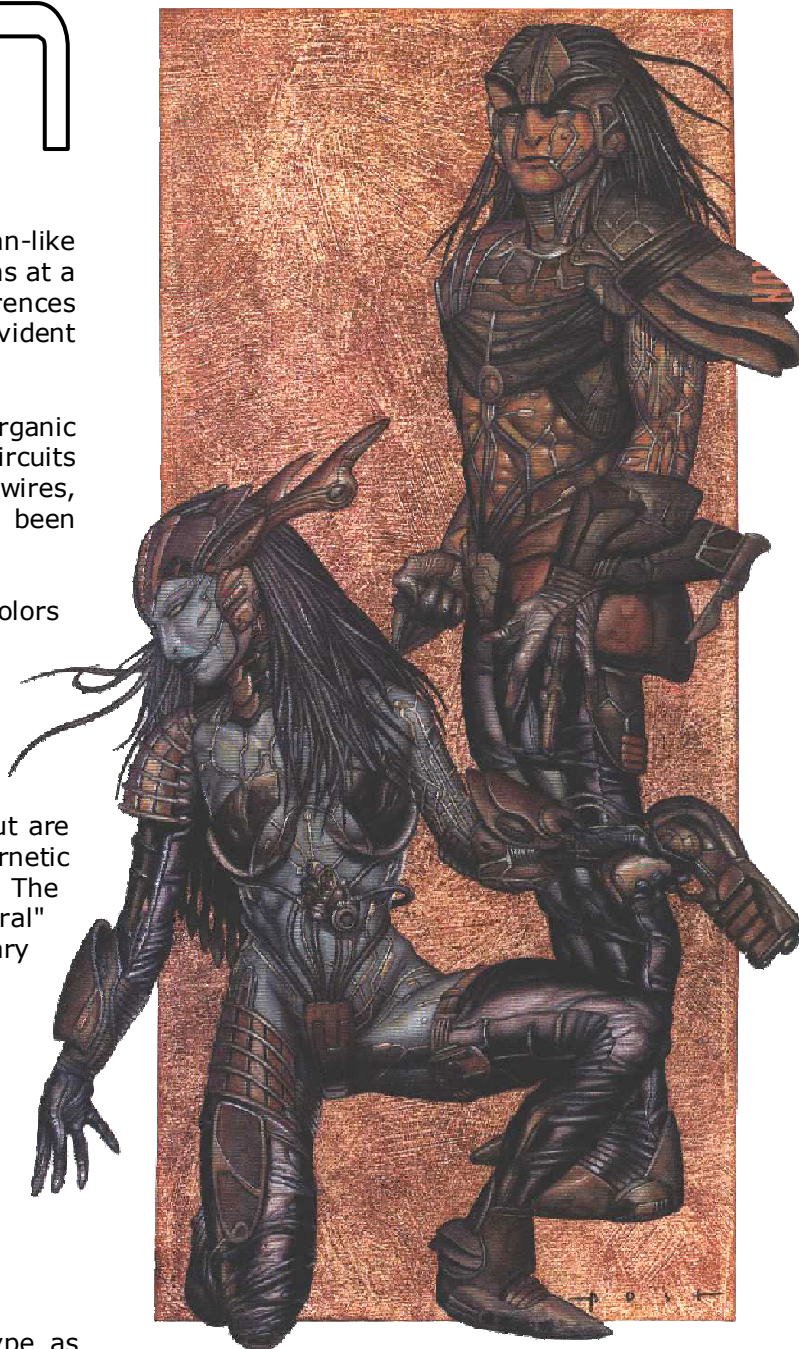

Aleerins do their best to downplay their negative emotions at all times. In comparison, when relaxed they play up their positive emotions, sometimes to the point where this joviality sometimes seem forced. While partially to remind other sentients that aleerins do experience the full range of emotion, this lopsided suppression of aggression, anger, fear and hate and strong display of friendship and humor is truly born out of the great shame of the aleerin race: during their early star faring years, the aleerins committed genocide on another sentient species with which they came into conflict. They carry the regret for that act to this day, woven into their culture as a distaste for the emotions which drove them to commit such a horrible act.

ATTITUDES

Because of their history, alerins try to be accepting of all sentient life. They are capable of distaste for individuals of any species, but they try not to be judgmental about other species as a whole. Their similarities to humans, both organically and in emotional capacity, intrigue alerins a great deal. Though they have conquered their own darker natures to some degree, alerins do not expect other species to do so.

Alerins are often called "mechalus", in both singular and plural, by other species. They do not mind this appellation, and wear it as a somewhat ironic badge of pride.

SPECIAL ABILITIES

Computer Skill Bonus: Because of their nature as a fusion of the living and the machine, alerins are capable of understanding computer systems on an intrinsic, instinctual level. By extruding a wire from her fingertips, an alerin may physically link to a computer system and become a part of it, able to issue commands to the system and interpret data from it at incredible speeds.

This innate ability to understand computer systems and physically link with them grants the alerins +10% to the use of any Computer subskill. If an alerin does not have the Computer skill, he may attempt to use a subskill of that skill at a flat rating of 10%.

◉ ALEERIN CHARACTERS ◉

Characteristics

| | |
|----------------------------|-----------------------------|
| Average Size | 1.8 meters tall |
| Average Mass | 90 kilograms |
| Average Lifespan | 250 years |
| Reproductive System | heterosexual, tank-grown |
| Body Temperature | 37 degrees Celsius |

Ability Scores

| | |
|----------------|-----|
| STR/STA | +5 |
| DEX/RS | +0 |
| INT/LOG | +5 |
| PER/LDR | -10 |

Movement

| | |
|----------------|--------------------|
| Walking | 10 meters per turn |
| Running | 30 meters per turn |
| Hourly | 5 kilometers/hour |

Special Abilities

| | |
|-----------------------------|---------------------------------|
| Computer Skill Bonus | +10% to all Computer subskills. |
|-----------------------------|---------------------------------|

ROLEPLAYING ALEERINS

Role-playing an organism that is half machine from birth can be challenging, especially when those beings control their emotions in such an unusual manner. Remembering this control can be difficult, but here are a few tricks.

Alerins do still feel their negative emotions. Their social conditioning encourages them to think before acting on these emotions, however, seeking to understand the clearer reasons behind anger, fear and hate. Because of their mental prowess, alerins are capable of analyzing these emotions so quickly that they usually don't seem to be thinking about it at all. By thinking through their negative reactions, alerins enable themselves to act as necessary without being ruled by those emotions. For example, an alerin caught in an ambush can still fight competently and even kill, if necessary, to save her allies, but she will not kill out of fear or anger. Rather, if she judged it necessary, she would kill to protect her friends and enable their mission to succeed.

On the other hand, alerin joviality can be equally daunting to handle. Alerins are not universal party-crashers, incapable of understanding subtlety and social niceties. Rather, they can be counted on to always put forward an optimistic view, or to laugh at a joke, even when others might roll their eyes or despair. They will not attempt to embrace a dangerous opponent, but will attempt to smooth over conflict between their associates and be friendly to all the parties involved. It is this insistence on positive reactions that often puts off members of species that are more free with their emotional expressions as artificial.

Alerin express their thoughts in speech with a peculiar mannerism. Unless they train themselves not to, they are prone to indicating the type, mood or tone of an upcoming utterance by prefixing it with a descriptor.

For example, an alerin pointing out that a vehicle is out of fuel might say, "Statement: we are out of fuel." This may be followed by, "Query: how far is it to the nearest fuel station?" (This mode of speech, in an expanded and brilliantly ironic form, was also used by the HK series of assassin droids in the "Star Wars: Knights of the Old Republic" computer RPGs. Players of the KotOR games could easily use the HK droids as a model, but would be advised to remove much of the heavy irony.)

FRAAL

PHYSICAL STRUCTURE

The small-statured fraal have pale grayish skin, large opaque black eyes and large, usually bald craniums. Their drop-shaped faces have only small slits for nostrils, earholes and mouths. Those fraal who do have hair sport stringy strands of silvery gray, pale yellow or white. Fraal have spindly, elongated limbs, five slender digits on each hand and almost wasp-waisted torsos, giving them a frail look.

SENSES

Fraal have excellent eyesight that expands slightly into the ultraviolet and infrared regions beyond human, but their tiny earholes don't capture sound nearly as well as humans' do. Because of this, fraal are quite visually-oriented.

SPEECH

Fraal speak as to most sentient races, with a larynx and air pumped from lungs. Their voices are soft and usually higher-pitched than those of humans. Fraal can speak any human tongue, but their native communication is often supplemented by their telepathic ability, which most other sentients can not match.

SOCIETY & CUSTOMS

The scientifically-oriented fraal travel the universe in vast colony ships, having long ago fled the destruction of their home. Their focus on mental abilities has given them a logical and controlled society, and their small bodies have given them a distaste for physical tasks, especially violence.

The most highly-regarded of studies among the fraal are those dealing with their mental powers. This is the closest fraal get to religion and philosophy, and they see very little value in artistic pursuits, which usually rely on intuition and emotion -- things the fraal have taken pains to suppress and control. Fraal also highly value scientific inquiry, especially with regards to exploration and learning more about other sentient races.

Because of their tight emotional control (much greater than the positive-focused alerins) fraal are often humorless without actually being dour. They carry an air of politely putting up with jokes and debates about such intangibles as philosophy among members of other species, patiently waiting to take logical control of the situation once more.

Because their emotions are suppressed, not destroyed, fraal can and often do form lasting and loyal -- but subtle -- friendships with sentients of many other

species. Someone befriended by a fraal may not even know it until the fraal does something drastic, such as overcoming her usual retiring nature in a physically dangerous situation in order to save her friend.

ATTITUDES

Fraal are considered somewhat timid, but they are also relentless in their pursuit of knowledge. They recognize the potential of any sentient species and regard art and humor with something of a parental view of children's play. Fraal are willing to share their vast stores of knowledge with others, but they often take a long view of such things, examining the possible consequences before doling out secrets.

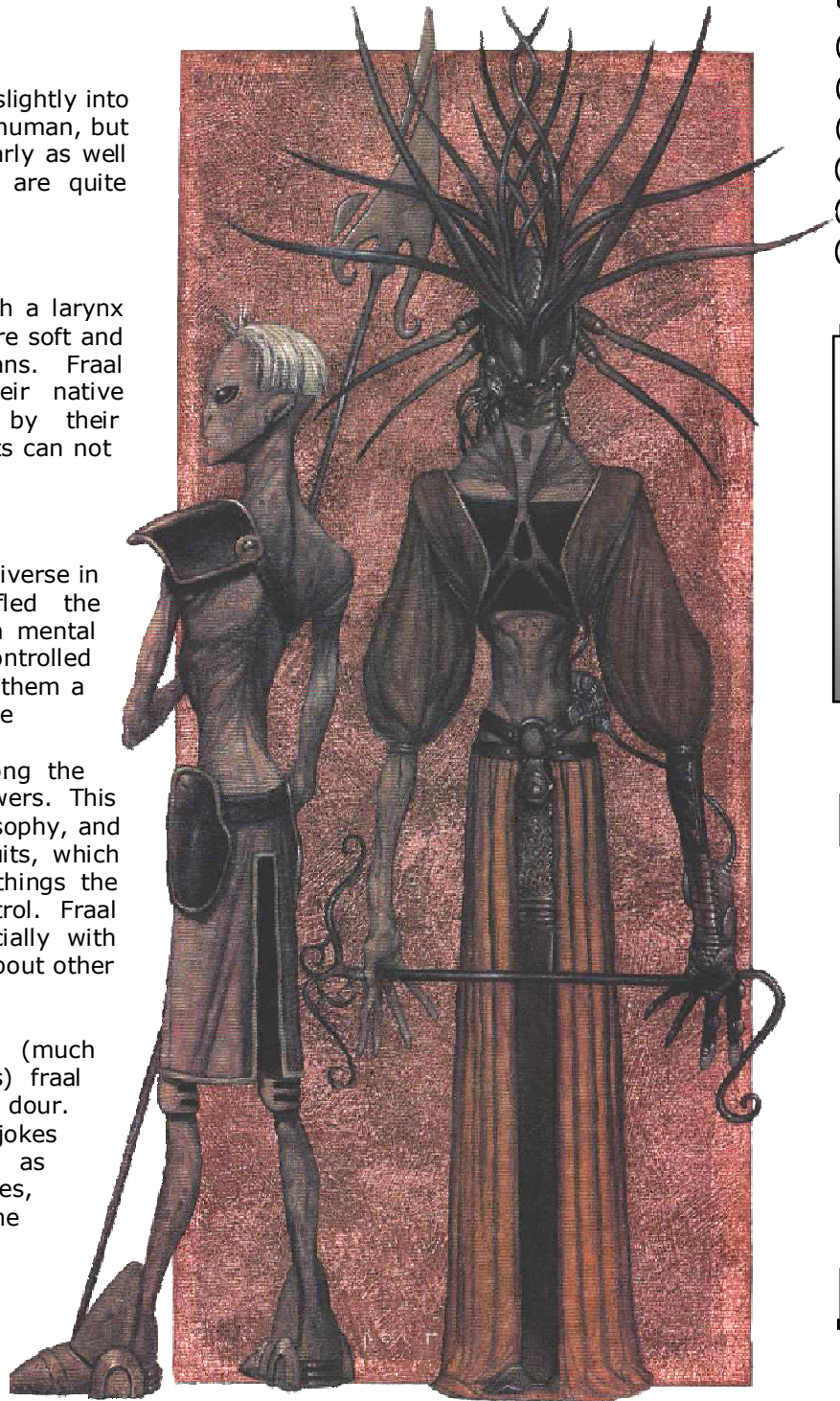

Among their own kind, fraal react with disdain toward any fraal who has abandoned the path of reason and embraced such things as art or religion. The cold cruelty with which "normal" fraal treat these "insane" social renegades is nearly universal, for according to the fraal to accept such things is to open the door to them in oneself.

SPECIAL ABILITIES

Read Thoughts. The natural telepathy of the fraal allows them to glimpse the surface thoughts of other sentient beings. This reading allows the fraal to pick up only limited impressions, thoughts which are immediate and uppermost in the mind of the sentient being "read". It does not allow a fraal to dig any deeper than those thoughts. For example, a fraal may be able to read the intent of a nearby human to draw a hidden weapon and shoot someone in the back, but the fraal cannot press further into the human's mind to find if the human is a hired hit man, the human's name, and so on. All fraal characters begin with a Read Thoughts score of 10, which may be raised in play through expenditure of experience points. Any time the fraal's player wishes to use this ability, the player should roll d100. If the result is equal to or less than the fraal's Read Thoughts score, the fraal character can pick up surface thoughts from the target. The range on this mental ability is approximately two meters for every 10% of ability or portion thereof (therefore, fraal begin play with a range of two meters, which increases to four meters at 11% ability, six meters at 21%, and so on).

Because of their familiarity with their own people, fraal may read the thoughts of another fraal at +10% ability (including a bonus two meters of range).

Send Thoughts. This ability allows fraal to attempt to make mind-to-mind contact with another sentient being and "speak" directly to that being. What is "spoken" may only be a few words; no more than a single long sentence at most (about 50 words). Fraal may communicate more using this ability, but must make a roll for each long sentence or small group of very short sentences. Any time the fraal's player wishes to use this ability, the player should roll d100. If the result is equal to or less than the fraal's Send Thoughts score, the fraal character can send a thought to another sentient. All fraal characters begin with a Send Thoughts score of 10, which may be raised in play through expenditure of experience points.

The range on this mental ability is approximately two meters for every 10% of ability or portion thereof (therefore, fraal begin play with a range of two meters, which increases to four meters at 11% ability, six meters at 21%, and so on).

Because of their familiarity with their own people, fraal may send thoughts to another fraal at +10% ability (including a bonus two meters of range).

Special Note: If the referee is using the optional Mentalist rules from the Alpha Dawn Remastered Edition, fraal may add their ratings in Read Thoughts and Send Thoughts to the Telepath subskills of the same name.

ROLEPLAYING FRAAL

The easiest way to understand the fraal mindset is to compare their outlook to that of an adult watching over a large number of beloved but rambunctious children. The fraal still feel emotion, but the power of their logic and reasoning has allowed them to separate their emotions from their actions and reactions. They consider the more emotional species to be more childlike, reacting without thinking through all the consequences first, and among themselves have adopted a patient, parental way of thinking about interspecies society at large.

This attitude is hardly arrogance. The fraal have displayed a sharp, if chilly, wisdom in their dealings with other species. Their care has allowed them to correctly discern when and where to distribute advanced technology, or when to pull back from contact with a species. The fraal never speak of themselves as superior -- they are far too wise for that -- but once they have made up their mind about whether another species is ready to receive the gifts the fraal have to give, the fraal do not change their minds.

NOVEMBER 2007

FRAAL CHARACTERS

| Characteristics | |
|----------------------------|--------------------------|
| Average Size | 1.5 meters tall |
| Average Mass | 55 kilograms |
| Average Lifespan | 200 years |
| Reproductive System | heterosexual, viviparous |
| Body Temperature | 38 degrees Celsius |

| Ability Scores | |
|----------------|----|
| STR/STA | -5 |
| DEX/RS | -5 |
| INT/LOG | +5 |
| PER/LDR | +5 |

| Movement | |
|----------------|--------------------|
| Walking | 10 meters per turn |
| Running | 30 meters per turn |
| Hourly | 5 kilometers/hour |

| Special Abilities | |
|----------------------|-------------------|
| Read Thoughts | 10%*, improvable. |
| Send Thoughts | 10%*, improvable. |

**+10 when used with other Fraal.*

SESHEYAN

PHYSICAL STRUCTURE

Sesheyans are probably the most alien-looking of the known sentient species. Their large, wedge-shaped heads have eight eyes and large batlike ears, and their slender, almost hunched bodies sprout great diaphanous wings that can extend as much as six meters in span. Both their wings and the fan-shaped organs at the end of their whipcord tails fold when not in use. Sesheyans have only three digits on their hands (two fingers and an opposable thumb) and have an ungainly walk when on the ground. Their skins are a mottle of green, gray and brown.

SENSES

Sesheyan eyesight covers a range just slightly more broad than human, but is most acute at either extreme, in the farthest red and violet bands, touching on infrared and ultraviolet. Because of their forest-hunter origins, they also have acute hearing. Otherwise their senses are close to human.

SPEECH

Sesheyans are capable of learning all human and similar languages with some effort. Their own normal language includes hoots, trills, clicks and growls that may be difficult for humans and near-humans to produce.

SOCIETY & CUSTOMS

The sesheyans come from a primitive hunter culture that has been forced into contact with galactic society. Sesheyan psychology still revolves around the hunt; they are patient and observant, seeming a bit detached to outsiders. Their social customs revere life, both predator and prey, and the rhythms and cycles of the natural order. They respect skill and prowess, but are dedicated to never taking more than they need from the environment.

Sesheyans as a whole are unfamiliar with advanced technology. Those few who wander the stars have learned to handle such things, but are still somewhat uncomfortable with anything beyond simple tools and their own skills. They often regard highly-advanced tech as magical and those who use it to be wizards or shamans. Sesheyans prefer primitive melee weapons, such as knives, and will sometimes use primitive ranged weapons such as slings or bows.

ATTITUDES

The sesheyans are simultaneously awed by and suspicious of those species who move among the stars. Sesheyan faith in their own dominance of the natural order has been shattered by these aliens from beyond

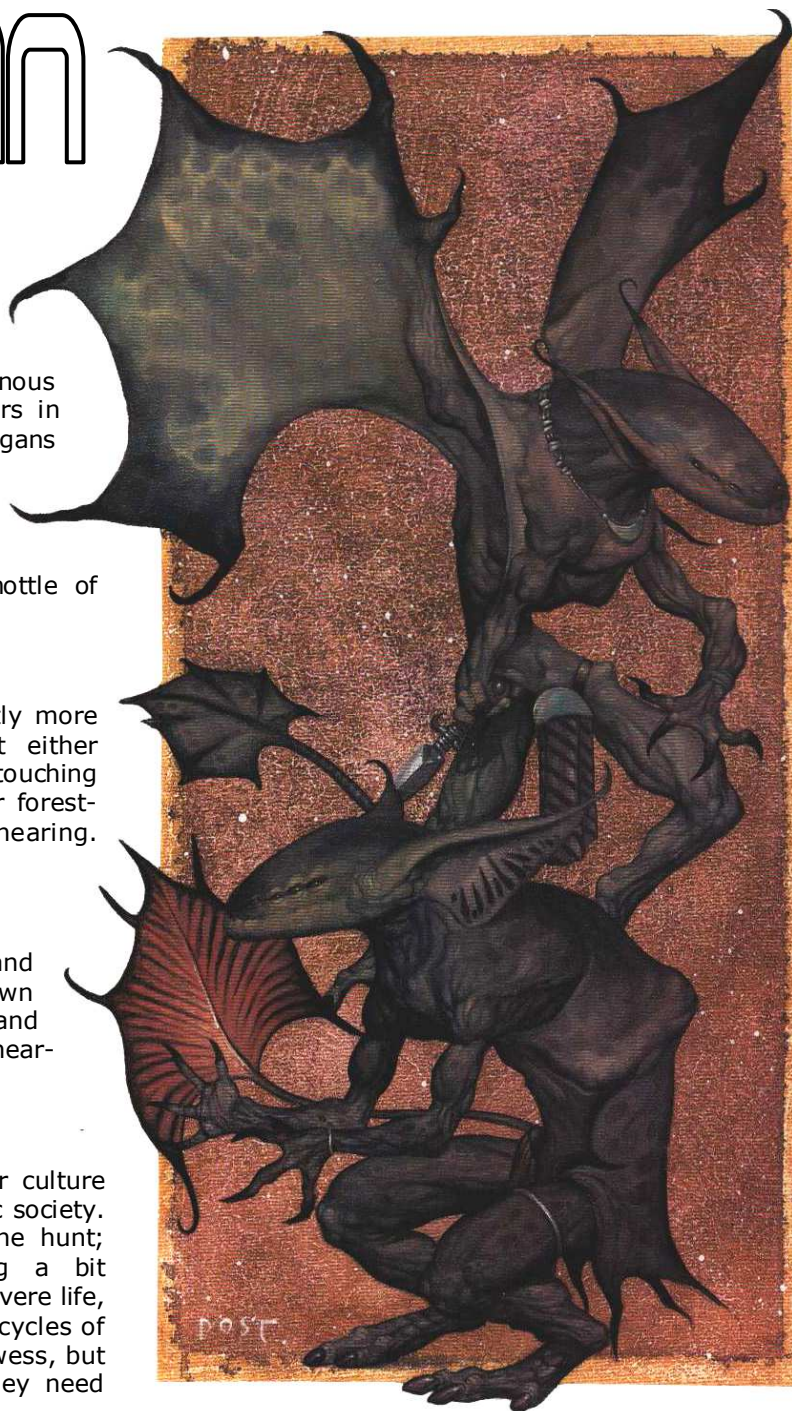

their world, and they are both fascinated and repelled by those who seem to have transcended nature. It will take some time for the sesheyans to develop deeper opinions.

SPECIAL ABILITIES

Flight. Their hollow skeletal structures, powerful musculature and large wings allow sesheyans to fly in Earth-normal gravity or less. Natural agility combines with their fan-like tails to allow sesheyans to move above the ground at their running speed with grace. The need for extra care in lower gravity counterbalances any advantages they might gain. Sesheyan ability to think in three-dimensional terms allows them to adapt very well to microgravity environments such as those in space.

Night Vision. Sesheyans evolved in a world of lush forests. Their eight eyes are capable of seeing very well in

dim conditions, just as yazirians. Also like yazirians, sesheyans suffer penalties for bright light. See the yazirian species entry for more details.

Technophobia. This is a penalty, not a special ability. Sesheyans are unfamiliar with advanced technology and suffer a -10% penalty to the use of any subskill in the Technological PSA. They also cannot take the Technological PSA as primary. Sesheyans can learn to overcome their primitive natures, but have difficulty.

ROLEPLAYING SESHEYANS

To play a sesheyan is to play a being completely out of its element. The hunters are surrounded by a million magical things they cannot hope to understand, because they simply have no context. How do you explain a starship to a sentient that has lived its entire life sheltered by the forest canopy?

The sesheyans that do travel the stars are considered to be supremely brave and more than a little crazy. Almost uniformly, these travelers have a zest for adventure and are not afraid of the unknown. They are also proud of their people and their own limited technology, seeing no need for the magic lightning-sticks or talking boxes that others use. They admit the usefulness of the ships that travel the forever-night sea of the sky, but only insofar as those ships get them from place to place reasonably quickly.

It may be that sesheyan brains are not quite yet evolved enough to understand advanced technology, but it is much more likely that what sesheyans want out of life can all be had with the power of wing, claw, blade and hunter's instinct. Their philosophies of life celebrate nature in all its forms and include little about things unrelated to life, hunting and death, so when everything that is important is all within oneself, what does one need with robots and gyrojets? This is the core of the sesheyan mentality, and it has served them well, both at home in the face of a

larger universe and among those who have strode out of the trees and into that universe.

Sesheyans do not proselytize their philosophies; either others understand or they do not. They will stand by those who have earned their hard-won trust, however, and try their best to respect the ways of life of the other sentient species they have encountered. Sesheyans react to the bewildering universe in which they have found themselves by not allowing it to change them any more than is absolutely necessary, and this includes defending one's tribemates.

SESHEYAN PRIMITIVE WEAPONS

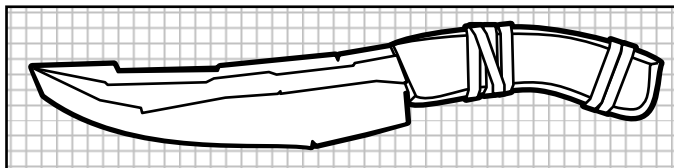

Stone Knife: While sesheyans do know how to forge metal, they often find it easier and more useful to chip razor-sharp blades from flint-like stone. A stone knife has the same properties as a regular knife, but on an unmodified roll of 00, the blade will chip, snap or break in such a way as to be rendered useless until it can be worked upon.

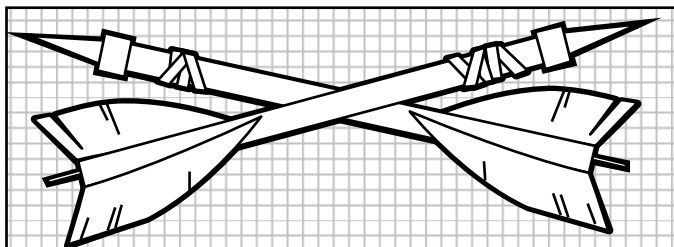

Dart Bomb: Taking advantage of the sesheyan ability to fly, this weapon resembles an arrow with a short shaft, curved fletching to set the dart spinning for stability, and a weighted point of either metal or stone. The dart bomb is thrown from above at a downward angle, delivering a punishing blow to the target. (Wgt 1kg, dmg 2d10, range: -/5/50/100/150, defense: inertia, note: range is for altitude and accuracy.)

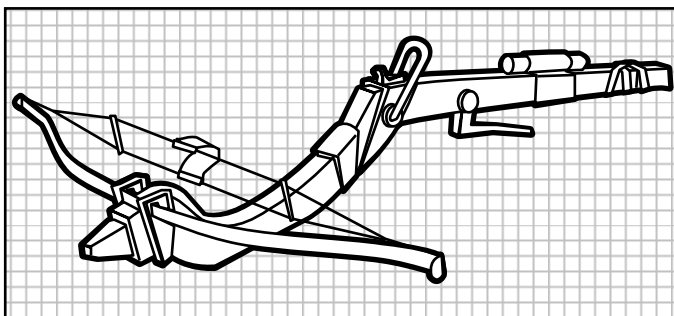

Sliverbow: A type of crossbow or pelletbow that represents the absolute pinnacle of sesheyan weapon advancement, the sliverbow launches thin, specially-knapped slivers of flint at startling velocities. On contact, the flint will tear through plants, flesh and other soft organic material with a vengeance; it will also shatter on contact with bone, leaving tiny pieces of razor-sharp stone imbedded in the target. (Wgt 2kg, dmg 2d10, defense: inertia, clip: 1, rate: 1, range: 5/10/30/50/70, note: ammo comes in bundles of 20 shots.)

SESHEYAN CHARACTERS

Characteristics

| | |
|----------------------------|--------------------------|
| Average Size | 1.7 meters tall |
| Average Mass | 40 kilograms |
| Average Lifespan | 150 years |
| Reproductive System | heterosexual, viviparous |
| Body Temperature | 38 degrees Celsius |

Ability Scores

| | |
|----------------|----|
| STR/STA | +0 |
| DEX/RS | +5 |
| INT/LOG | +0 |
| PER/LDR | -5 |

Movement

| | |
|----------------|--------------------|
| Walking | 10 meters per turn |
| Running | 30 meters per turn |
| Hourly | 4 kilometers/hour |

Special Abilities

| | |
|---------------------|-----------------------------------|
| Night Vision | -15% all actions in bright light. |
| Flight | Normal move rates while airborne. |
| Technophobia | -10% all technological subskills. |

T'SA

PHYSICAL STRUCTURE

T'sa are small, lithe reptilian beings with wiry musculature and impressive crests rising from the back of their skulls. They are covered in scales of varying sizes, largest on their backs. They come in a variety of colors, including brown, green and dark red. They have only two large toes on their feet, but have three fingers and an opposable thumb on each hand. Their slender tails often lash about behind them.

SENSES

T'sa vision, hearing, smell and taste are very close to human levels. Because of their scaly skin, t'sa are less sensitive to touch than many other sentients.

SPEECH

T'sa are capable of learning human languages and similar tongues, though they speak with a distinctive "accent". Their native language includes growls and hisses which humans and other sentients may find difficult to properly reproduce.

SOCIETY & CUSTOMS

The t'sa are incredibly social creatures. They are naturally gregarious and cheerful as well as insatiably curious. T'sa are quick to make friends and greatly prefer social groupings to solitude and teams to individual efforts.

Because of their driving curiosity and technological aptitude, t'sa interstellar society is quite advanced despite the relatively short time they have had the capacity to reach other stars. Given time, they could easily surpass other sentient species and leave them behind, but the social nature of the t'sa leads them to share their discoveries so that their friends can stay with them.

The always-moving t'sa are known for getting into trouble, not out of some perverse desire for difficulty, but because they obey their inborn imperative to find things out. They often rely on friends to hold cooler heads and keep them out of hot water. This is a display of trust by the t'sa toward those they call friends and allies.



ATTITUDES

The t'sa are not generally a violent species, preferring interaction and diplomacy to win over others. Though they seem naive to some, the t'sa never give up hope in any situation. They welcome contact from sentients of any species, though they do tend to prefer relations with the less violence-prone.

Because of their dislike of being alone, the t'sa will readily form friends with almost anyone who will put up with their fidgeting and rapid-fire stream of talk. The t'sa are not naive, though their childlike energy may make them seem so; they will recognize a bad person as such. They just like being around others so much that they'll give almost anyone a chance. As friends and allies they are enthusiastic and loyal, dedicated to preserving their social groupings.

Their uncanny knack with mechanical systems means t'sa will often seek a mechanical approach to a problem, rather than force or diplomacy. Obviously, if a situation has no mechanical solution, the t'sa will resort to other methods, but if a way can be found to apply technology to a problem, the t'sa will find it.

SPECIAL ABILITIES

Juryrig. The endless curiosity of the t'sa serves them well when poking into mechanical systems. As well, their natural speed allows them to try multiple solutions to a problem in the time most sentients can implement only one.

Together, these abilities allow t'sa to tinker with and patch-repair such systems with ease. T'sa characters gain a +10% bonus to all Technician subskills. If a t'sa does not have the Technician skill, she may attempt to use a subskill of that skill at a flat rating of 10%.

ROLEPLAYING T'SA

The t'sa are, overall, a young and optimistic species. Their penchant for mechanical and technological advancement has taken them to the stars well

before they had a chance to become jaded by the dark side of technology. Their sociable nature channeled their development down avenues much different from the human penchant for ever-more-deadly weapons, so they never threatened themselves with extinction from the products of their own minds. This has given them a positive outlook about the future and about technology in general.

This is not to say that the t'sa do not get upset or afraid. The t'sa are just as quick to let go of anger as they are to be sparked off, however, and are likewise just as quick to express their dislike of food that does not agree with their tastes or their love of a beautiful sunset. Much like their constant motion, the t'sa's emotions are always flowing naturally from one state to the next, almost like a child. They also do not care much for being alone for extended periods, which means that they often offer to tag along on almost any trip or chore.

As a t'sa, you abhor too much stillness and quiet. You talk fast, you talk a lot, and sometimes you think so fast that what you're saying changes midsentence, but you can be counted on. Your mind is always active. Ideas generate, change, split, recombine and evolve inside your head like the flowing of a river, a constant thing that can only be diverted or channeled, but never stopped. Everything has potential, and just because something works well does not mean it couldn't work better, or serve another purpose. You love to dig into things, which would be annoying and dangerous if you weren't so good at putting them back together again. If you have nothing else to do with your hands, you're probably disassembling something just to see how it works!

T'SA WEAPONRY

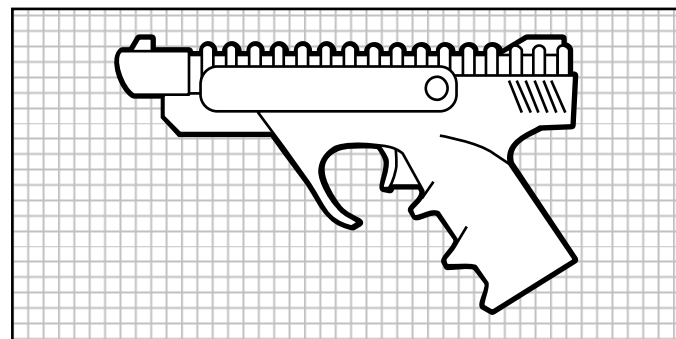

Microstunner: This small, handheld t'sa invention has only one purpose, which is to stun its target. Like the sonic stunner, it only causes stun, and does no actual damage. Unlike the sonic stunner, it relies on pulse beam technology. (Cost: 500; Wgt: 1kg; Dmg Stun; Ammo SEU; SEU 2; Rate 1; Defense Albedo; Range 5/15/-/-/-)

T'SA CHARACTERS

Characteristics

| | |
|----------------------------|-----------------------------|
| Average Size | 1.4 meters tall |
| Average Mass | 23 kilograms |
| Average Lifespan | 150 years |
| Reproductive System | heterosexual, ovoviviparous |
| Body Temperature | 39 degrees Celsius |

Ability Scores

| | |
|----------------|----|
| STR/STA | -5 |
| DEX/RS | +5 |
| INT/LOG | -5 |
| PER/LDR | +5 |

Movement

| | |
|----------------|--------------------|
| Walking | 15 meters per turn |
| Running | 35 meters per turn |
| Hourly | 6 kilometers/hour |

Special Abilities

| | |
|----------------|-----------------------------------|
| Juryrig | +10% to all Technician subskills. |
|----------------|-----------------------------------|

WEREN

PHYSICAL STRUCTURE

Weren are massive, fur-covered brutes standing over two meters tall and packed with muscle. Males sport large tusks jutting from their lower jaws and flying manes of tough hair. Their great hands sport five sharp claws, one from every digit, and their broad feet are shaggy and padded, a legacy of their descent from predators of snowy lands. The color of their fur ranges from white to gray and black, with some shades of brown as well. This fur has a shimmering quality that causes a very slight blur, which can hinder attacks upon them by disrupting the vision of their attacker.

SENSES

Weren senses are all near human normal, though their sense of touch is hindered a bit by their fur, and their sense of smell is more acute because of their heritage.

SPEECH

Weren speak with lungs and a larynx. They can speak human languages with difficulty, as their mouths are structured somewhat differently from near-humans. Weren language incorporates rumbles, growls and grunts along with more "normal" phonemes and can be difficult for humans and near-humans to speak. Often times weren will learn the languages of others but speak their own language, trusting their compatriots to do the same.

SOCIETY & CUSTOMS

The weren are passionate beings evolved from mighty predators. They pursue any task or belief with zeal surpassing all but the most dedicated of other species. While built for war -- and indeed the making of war is their most notable ability -- weren throw themselves at life with incredible intensity.

Weren society is technologically backward, at a level equivalent to Earth's early Renaissance, but their social culture also resembles this period of human history, full of inquiry, debate and learning. A debate between weren can be as heated and as quick to change as physical combat, but contrary to expectations, open combat does not erupt between two weren who simply disagree with each other. A weren advocate of any cause is both a valuable ally and a terrifying foe.

Weren do not suffer from technophobia as do the sesheyans, but they do prefer to use technology of their society's level. This is both a matter of unfamiliarity and one of pride to the weren; they would rather prove that they can make do with what they have made themselves than risk making themselves look foolish with advanced technology. Thus, they continue to use steel blades, bows and black powder firearms while their allies use vibroblades, lasers and gyrojets.

ATTITUDES

The weren idealize strength -- not just physical strength, but also strength of mind and of belief. They regard with some suspicion those species who have set aside or muted their passions, not understanding how any sentient could live such a life.



SPECIAL ABILITIES

Claws. Weren sport natural claws on their hands and feet. These natural weapons can be used to make an attack for 1d10 damage even when the weren is unarmed. Defense against the claw attacks is inertial (inertia screens, skinsuits, etc.)

Camouflage. A weren who holds still while standing against some sort of backdrop, be it natural foliage or rocks or an urban wall, can use the slight light-warping properties of her fur to make it more difficult to hit her. If a weren moves 2 meters or less during a turn and is close to an appropriate backdrop, all attacks against the weren from sight lines including the backdrop suffer a -10% penalty.

Night Vision. Because of their descent from highly-successful predators, weren see very well in dimly-lit conditions. This is the same as the yazirian and sesheyen special ability. See the yazirian species entry for more details.

ROLEPLAYING WEREN

The defining aspect of the weren, more than their physical power, more than their keen hunters' instincts, is their enthusiasm for everything that they do. If anything is worth doing, to a weren it is worth doing to the utmost. While this can make them boisterous and rowdy, it also makes them fearsome philosophers, scientists and protectors of peace. Weren do not focus on individual life-pursuits, per se; instead, they follow their interests to the logical and ultimate conclusion. If they feel they have achieved all they can in a particular field, they often become bored, and move on to something else, adding to their already-prodigious repertoire.

Big doesn't mean dumb, and the weren find themselves underestimated time and again because of their hulking size. This allows them to surprise their enemies with their sharp intellect both in peace and in battle. While weren ferocity in individual combat is legendary, their tactical genius is just as dangerous, if not more. Because they rely on a much lower level of technology, weren make excellent leaders in times of deprivation and hardship.

As a weren you believe in technological advance, but you are content with your own rate of such advance, and find that your black powder weapons serve you just as well in the field as your allies' blasters. You can't deny the power of advanced technology in many areas, but you also can recognize how you might achieve similar effects with more familiar methods. To you, dedication and knowledge are more important than hardware.

You also have your own particular brand of honor. Standing by your family and friends is good and right, as is following your heart. Deception in open conflict is admirable, but deceiving others simply to advance your own standing is wrong. You may not make friends among non-weren easily, because your size and passion are intimidating, but you will stay with those who open themselves to you through any hardship, until they prove themselves unworthy of your devotion.

WEREN CHARACTERS

Characteristics

| | |
|----------------------------|--------------------------|
| Average Size | 2.2 meters tall |
| Average Mass | 180 kilograms |
| Average Lifespan | 250 years |
| Reproductive System | heterosexual, viviparous |
| Body Temperature | 38 degrees Celsius |

Ability Scores

| | |
|----------------|-----|
| STR/STA | +10 |
| DEX/RS | -5 |
| INT/LOG | +0 |
| PER/LDR | -5 |

Movement

| | |
|----------------|--------------------|
| Walking | 10 meters per turn |
| Running | 30 meters per turn |
| Hourly | 5 kilometers/hour |

Special Abilities

| | |
|---------------------|---|
| Claws | 1d10 inertia damage |
| Camouflage | opponents have -10% to hit if weren moves 2 meters or less during his turn. |
| Night Vision | -15% all actions in bright light. |

WEREN BLACK POWDER WEAPONS

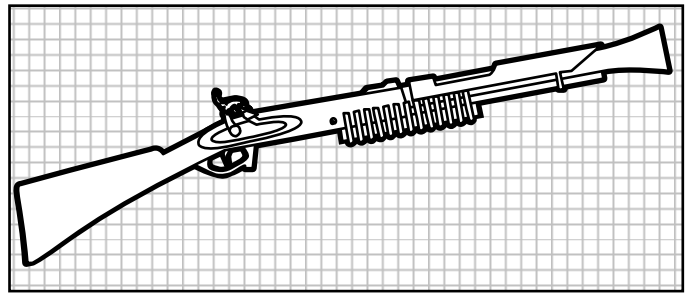

Rifled Musket: A great advance over older muzzle-loading flintlock weapons, the rifling in the barrel of this weapon (source of the word "rifle" for a longarm) sets the bullet spinning, giving it much better accuracy over greater ranges. Weren muskets are scaled up in size, causing commensurately greater damage. (Cost: 300Cr, Wgt 3kg, dmg 3d10, defense: inertia, range 5/20/50/80/120, clip: 1 shot, rate 1, note: 1 weren powder charge requires 2 standard charges.)

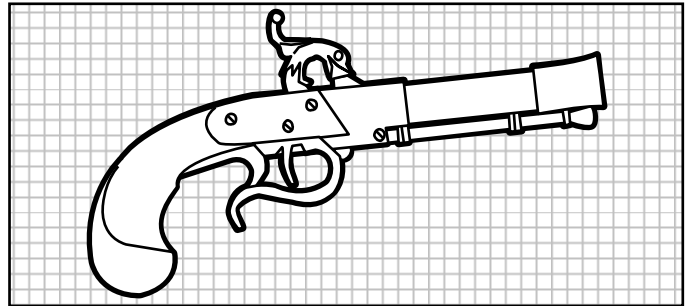

War Pistol: This single-shot pistol resembles the famous muzzle-loading flintlock pistols of ancient Earth. It is, however, weren-sized, which means it carries a significantly larger powder charge and bullet, doing quite a bit more damage. (Cost: 200Cr, Wgt 1kg, dmg 2d10, defense: inertia, range 5/15/40/70/100, clip: 1 shot, rate 1, note: 1 weren powder charge requires 2 standard charges.)

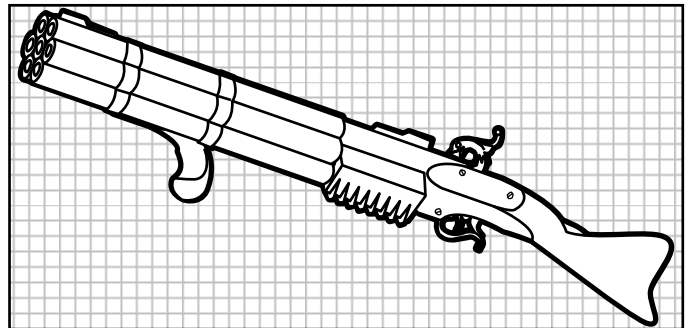

Weren Pepperbox: A nasty conglomeration of seven barrels, a central barrel surrounded by six more, with each loaded with a single bullet and powder, the pepperbox (a different weapon from the human gun of the same name) is designed to blast away an opponent in one shot. The barrels and bullets are a bit smaller than normal, and the accuracy at range is horrible, but the effect of a hit is devastating. (Cost: 450Cr, Wgt: 2kg, dmg: 4d10, defense: inertia, range 5/10/20/30/40, clip: 1 blast, rate 1, note: uses 7 bullets and powder charges at once and takes 3 turns to reload.)

Weren Powder and Shot: Because of the larger size of weren weapons, which use roughly double the powder of human versions and bullets of increased size, the price for 20 bullets and charges of powder is 20 credits instead of 10. Weren can use powder from other sources, keeping in mind the need to use twice as much, but improperly-sized bullets cannot be used in weren weapons. Many weren know how to make their own powder, however.

CREATIVE REFEREEING

By Brian
Conway

Editor's Note: Also known as "Imperial Lord" on various community RPG sites, Brian has been running online games and giving his 2 cents in the forums of www.starfrontiers.org for quite a while. His creative refereeing has always impressed me. I have read this article twice and personally plan to use these insights as gospel. He invites anyone who wants to contact him to drop him a line: uesredux@yahoo.com

So what makes a good Star Frontiers referee? If I need to identify a single word, it is preparation.

It is important to understand that a referee's job is storytelling. That is the primary focus. Unlike fantasy games, there is very little "open the door, kill the monster, take the treasure". Such an approach is not appropriate for Star Frontiers. Experience points, again unlike fantasy games, are given at select points in the adventure, and are strictly based on unraveling the story you are trying to tell. The idea of roaming the woods and killing wild boars for XP just does not exist in Star Frontiers.

The best Star Frontiers adventures are partnerships between the referee and players. The referee presents events and challenges and the players respond. There are many types of events - from rather meaningless random encounters to critical plot points where the players must choose wisely or face failure - or death. These event types have been well explained in previous articles. Suffice it to say that these events are the meat and drink of a good Star Frontiers adventure.

GETTING STARTED

When considering a campaign, you must ask the following questions: What is the point? What is happening? In Hollywood terms, this is known as a "treatment." This is usually one or two paragraphs, nothing more, which explains what the point of the story is. This is the first step. This will provide the skeleton for your story. For example:

"Capellan Free Merchants has had a security breach at one of their isolated research labs. The party must investigate the breach and as they do, they realize that the lab is actually a target of Sathar agents. CFM is surprisingly unmoved by this discovery, and refuses to report the conclusions of the party to the UPF and Star Law. CFM then begins to undermine the party's effort, such that the party has to fight CFM almost as much as the Sathar! Finally the party manages to find Sathar agent's secret transmitter and destroy it, and then must make a harrowing effort to report everything to

Star Law, which comes to the player's rescue just in time, to stop CFM's cover-up."

Here we have a good start. Now, we need to put some meat on the bones. The next step is to start asking yourself (or rather your treatment) questions. You notice that many of the statements in the treatment are vague. That is perfectly normal - it is a treatment! So let's put together some questions of this little paragraph, the answers of which will flesh out our story.

1. Where is the lab and why is it so remote?

The lab is tucked away on a distant planet. What is its environment? Is CFM involved in illegal weapons research? Illegal drug production? Improper manufacture of cybots?

2. What is the nature of the security breach?

Was it a raid? Is there a follow up raid, to provide some combat to the players? Were the computers hacked? Was a tunnel discovered? Were secret transmitters or bugs placed around the lab? Was it a combination of the above? This part of the adventure could be stretched out into several XP junctures, becoming a small adventure in and of itself.

3. Why are the Sathar interested in CFM's research?

Probably because of the answer to question #1. Or, perhaps they are going to warp CFM's research into a twisted new weapon? How can the PCs figure this out?

4. CFM is unmoved by the PC reports of Sathar agents - why?

Again, this goes back to question #1. Maybe this is a corporate cover-up? But maybe there are Sathar agents at the research lab? They don't want to kill the PCs yet, but certainly want to stop the party from uncovering the full situation. Who can the PCs trust?

5. How does CFM undermine the PC efforts?

Do the parabatteries of the Explorers assigned to the party mysteriously go dead as they search the small planet for Sathar agents? Are they sent on wild goose-chases? Are their issued weapons loaded with blanks?

6. Where is the Sathar agent's transmitter, and how is it guarded?

7. How do the PCs get the word out to UPF/Star Law?

And so forth. Write your treatment, and poke and prod at it with questions. Answer all the questions possible. Again, these answers will be vague, but at least now

there is some meat on the bones. Once the questions are answered, you should be able to divide those questions into tangible events. Based on our little exercise here, we can build a decent module with the following adventure subsections:

1. Introduction & Breach at Lab
2. Discovery of evidence and report to CFM about the Sathar
3. Wild goose-chase #1
4. Wild goose-chase #2
5. Ambush by Sathar agents
6. Players strike back at Sathar transmitter base.
7. PCs discover the traitor, uncover the research lab purpose
8. PCs manage to contact UPF/Star Law, and narrowly escape on a UPF cruiser.

Now you need to get specific. Ask more questions – now of each of your subsections. Let's take #1. How do the players get this job in the first place? How much do they get paid? Who are the main NPCs at the lab and what do they do? Who is the traitor, if there is one?

LINEARITY AND WHAT TO DO ABOUT IT

Soon, each subsection forms its own chain of events. This is where refing becomes a fine art rather than a science. The most critical part of your job is to avoid what I call excessive "linearity" – which is that bane of all RPG game-mastering. Linearity is when a story proceeds from A to B to C to D to E to F to G, etc. The players are "playing" – they are moving around, fighting, recovering, and so forth, but where are their choices? Actually, they are just rolling dice and watching.

Remember what I said early in this article – a Star Frontiers campaign is a *partnership* between you and your players. Your PCs are not tourists or patrons in a movie theater. They are active *participants*. Therefore, it is vital that the referee provides multiple ways to "skin the cat" on each adventure subsection. This makes a referee's job much harder. Not only do you have to write the story, but now you have to weave together multiple options to avoid linearity.

Some linearity is necessary. All RPGs have the dreaded city scenario, where inevitably some PC wants to "run down an alley" or "start opening doors". This has happened to me as a GM in almost every game I have run. What is down that alley? I only have a path on my map... Which door? Who is behind that door? What are their stats? Total nightmare. Linearity helps prevent this.

Linearity can also help the story move. In a campaign that I am running right now, the players are on the run, escaping from assassins who are trying to kill them. They *don't have time* to knock on doors and run down alleys – they are getting shot at constantly! My point is that some linearity is necessary. Sometimes it makes your action exciting and builds a sense of life-

or-death urgency. But your entire campaign cannot be linear. So what are some techniques that referees can use to avoid this pitfall?

One method that I like to use is what I like to call "clue drowning." This is to drop so many possible clues as to the purpose of the subsection that is almost unimaginable that the PCs would not figure out the point and move forward. XP can be awarded for finding clues – or they can be awarded for NOT finding clues, i.e. figuring out the story without needing the extra clues. Time pressures can be added to provide additional urgency.

The advantage of clue drowning is that you can allow the players to wander about and figure things out on their own. This reduces linearity. Let's go back to the lab for a moment. The players have to find out about the breach. Give them some initial start-points. Maybe some witness interviews of some of the workers at the lab will lead them to clues. Examination of the location of the raid is always a good idea. Some information of CFM's computers might be helpful. Perhaps the radio transmissions from the raiders were detected and stored somewhere, waiting for the players to find. The clues may not all need to be discovered to achieve the goal of the subsection. These clues stand on their own, and can be detected in any order. This will give the players the sense that they are driving the story, which is always the best outcome.

"Red Herrings" are also important. These are "clues" which are actually meaningless. All good campaigns have them. The trick is to make them realistic enough to distract the players, but not to make them so overwhelming that they deviate or, even worse, block your story. The idea about red herrings is to somewhat confuse your players and make them feel overwhelmed by the mysteries of your story, even if for a short time. For example, maybe one of the humans in the research lab is gone at strange hours during the night, sometimes even during his shift. Is he a Sathar agent? No, actually he is carrying on a torrid affair with an equally desperate human female worker down in Maintenance! This embarrassing situation is against company policy and unprofessional, but has nothing to do with the security breach. This is a perfect example of a red herring. How the PCs handle it may even result in an XP or monetary penalty, if they run into the Motor Pool guns blazing and make idiots of themselves. Red herrings make your story fun and keep your players on their toes. Just don't overdo it.

Another technique is known as the "Golden Path." This is the answer to the following question: If your players played your campaign *perfectly*, what would they have to do to accrue the maximum XP? Then you set out your Golden Path and work backwards, watching for possible deviations from it. Then you flesh out those deviations into events, encounters, and possibly even subsections that may never be played. Usually it is best to create your Golden Path last, to use it as a method of proofreading the feasibility of your story.

Ultimately, it comes down to preparation. You may even be required to "wing it" to a degree. But a good referee improvises things like combat tactics and conversations with shopkeepers and such. Your preparation will limit your improvisation to a minimum. If you find yourself improvising frequently, particularly on important plot points, then you have not prepared well enough. While this is not the end of the world (or galaxy), it is a mistake that you should not repeat. Improvisation is a part of Star Frontiers refereeing, just like in all other games. If I wore spikes on my hand, I would be dead right now from all of the times I have hit myself in the head and said, "Why didn't I think of that?" as some player blurts out some idea that undermines a key part of my story, or uncovers a plot point that should not come forth until much later in the campaign! Your preparation is the only protection you have against such a calamity. You need to anticipate, as best you can, every single possible twist to your plot points.

SOME THOUGHTS ON COMBAT

Some notes about combat. Everyone loves combat – more than half the rules are based upon weapons and armor and battles. I try to have at least one battle in every adventure subsection, and usually have several. Play balance here is very important. Try to imagine how each of your players will handle the combat. Give them fights that they can win, and again, try to weave them into the story. Expending endless ammunition and medicines on "wandering monsters" slows down your game, weakens your players, and annoys everyone. Nonetheless, wandering monsters can serve as a useful tool to prevent the players from straying too far into the woods and losing focus on your story. Hopefully, after expending half of their clips and biocort from fighting roving bands of rasties, the players will take the hint and get back on the road to their goal.

Keep in mind the deadliness of Star Frontiers combat. A level 6 Beam Weapons bad guy with a laser rifle set on 20 SEU and a Power Backpack is almost guaranteed to kill a PC in a single shot, maybe two if the PC has Albedo protection. And he would not have gotten to level 6 Beam Weapons if he kept his laser rifle on 1 SEU! Sathar Attack Monsters such as Cybodragons or Quickdeaths can make short work of most parties, especially if they attack from ambush or a beneficial position. Even in the Voltornus series of modules, I was shocked by the difficulty of some of the encounters. Some of the other modules are even more ridiculous with their combat. Be prepared to modify accordingly. Overall, it is better to err on the side of easier battles than harder ones. However, stupid players should always be exposed to heavy fire. Then let the dice fall where they may.

EXPERIENCE POINTS

Note that each of the subsections should be an XP juncture. I have never liked the book's description of XP being allocated based on a "night" of adventure. What, exactly, constitutes a "night" of playing? This is a silly measurement. XP should be allocated at

meaningful junctures, similar to the modules provided by TSR.

The amount of XP has been discussed in other articles – Bill Logan has a great example in a previous issue as to how to do this. But you should also add XP incentives on two levels to PCs, in addition to his suggestions:

1. Group Bonuses

These XP bonuses are for the players discovering certain features of the story or engaging in *meaningful* side combats and subplots. In fact, you should have XP bonuses for PCs *avoiding* certain fights and events, because they only serve to weaken them and have no impact on the story.

2. Individual Bonuses

These are similar to Group Bonuses, but are designed to reward specific players. Usually this is given for the PC that discovers certain key plot points to your story. Many other instances are possible – innovative battle tactics, great role-playing, convincing other NPCs to help the party that otherwise would not have, etc.

Note that each surviving PC should get *something* for finishing the juncture. But the Bonuses serve as a great incentive for players who are just "there to shoot things" or are "along for the ride." Players that think about the story, work for the resolution, and solve the problems that you present are rewarded, and will proceed faster in your campaign than the slackers. Every RP gamer notices when one guy reaches Level 3 and he is only on Level 2... The object here is not to play favorites or ridicule anyone, but to galvanize everyone to play better. Be careful not to alienate your players – remember that without them, you have no game. Overall, it is better to be generous with XP than stingy.

In terms of penalties, the only penalty I give is for dying (going below 0 STA). This is meant to deter the mindless bravery associated with knowing that, right around the corner, there is a PC with medic skill with a Freeze Field or Staydose. Depending on the number of XP given, I will penalize the "dying" player with 20-25% of the total XP. So for example, if the XP juncture awards 5 XP, I will subtract 2 from the player that died.

When a character dies permanently, it is important to find a way to get that player back in the game as quickly as possible. As a penalty, however, I normally have a re-rolled character to start at 1 level lower than the lowest level PC in the party. So if the lowest level player is 4, then the newly rolled player should be level 3 in whatever skill or PSA that the new player chooses. This gives a solid penalty to the dying player, but also allows them to stay "in the ballpark" with the rest of the party. Having them roll up at level 1 may weaken the party so much that you may need to "water down" all of your other encounters. Dying in RPGs is always frustrating and painful for a player. A good referee will always review the encounter, and then all future planned encounters, to ensure that they will be as

balanced as possible and give all players the best chance to survive.

NPCS IN STAR FRONTIERS

NPC followers are a critical component of all Star Frontiers campaigns. They allow a conduit between the PCs and the referee. Through this conduit, you can give vital clues, if absolutely necessary, to keep the game moving along the storyline. Additionally, they make great sense – would a megacorp or the UPF entrust multi-million credit equipment to the PCs without one of “their men” along to watch over it? Or, if the party frees a hostage who is a former soldier, why wouldn’t he fight to help his liberators? It is very easy to insert these characters into the party.

Be cautious about NPC follower traitors. This is a dangerous move by a referee and must be done only with great care and tremendous relevance to the story. More than likely, such a traitor will pick the best (i.e. worst) possible time to reveal himself, blasting the nearest PC with a 20 SEU laser pulse in the back during a tough fight! Now a supposedly loyal NPC follower has killed one your PCs, and more PCs may die because of the sudden change in the balance during that encounter. Even more importantly, the entire party will be very wary to allow another NPC into their ranks. Now you have severed an important conduit of information between your players and yourself, as I described above. This will not only affect your current campaign, but that trust will be poisoned for all future campaigns with those players.

In terms of XP for NPC followers, I only award them Group Bonuses, and never Individual Bonuses. After all, it is the PCs job to discover the Individual Bonuses! This will slowly result in the PCs overcoming the NPC followers in XP points and levels, and that is perfectly acceptable. After all, the PCs should be leading the NPCs – they are the ones playing the game.

TECHNOLOGY, BEING BAD GUYS, AND HELP

I do not take the whole issue of “technology feasibility” seriously. Devices and weapons work because the referee said so, and do not require any further explanation. Focus on your story, rather than explaining the chemistry and physics of every single doo-dad in your campaign. Perhaps there is some important gadget in your story that needs explaining – but you should do so only if your story requires it.

It is also important to understand that the Frontier is a relatively civilized society. Walking around with rocket launchers and poison grenades is not going to be tolerated in most areas of the Frontier. Think of your own town, and the laws regarding weapons are probably similar throughout the Federation. Killing Frontier citizens is murder, and will be investigated and punished accordingly. As such, a referee needs to impress upon his players the need to figure out certain situations without mass killing. Pointing guns at every NPC that disagrees with them, taking hostages and pumping them full of Telol, or forced hypnosis, and

other such criminal methods should only be a last resort. These kinds of forceful methods are also cop-outs, and can ruin your carefully created sets of clues and events. This is unless, of course, your PCs want to be criminals. However, a referee should be warned that a campaign involving criminal PCs is more difficult than one where they are non-criminals.

Criminals on the run have a vast series of challenges set upon them. Just getting basic necessities such as food and water will be a difficult, let alone weapons and equipment. Setting foot on any part of the civilized Frontier, except for maybe the Outpost planets, will incur the wrath of Star Law sooner or later. If the PCs manage to kill Star Law Agents, then the heat will increase exponentially. Bounty hunters will come after them also. Criminal campaigns are much more difficult to run than non-criminal, I have found. Having to insert a Star Law squad attack every single time the players return to civilized Frontier space is annoying (if they don’t attack, then the campaign is not realistic.) Every single crooked merchant dealing with the party will be tempted to collect the bounty, which will be substantial if the PCs murder multiple Star Law agents. Combat will be constant and deadly – it is hard to imagine the players managing to survive for long.

There are simply too many variables, plus I have found that many PCs in criminal campaigns want to steal from and/or kill each other, resulting in PC-on-PC battles that I find intolerably dull. As a rule, when I see a PC pick up dice against another PC, I get up from the table and leave, whether I am reffing or playing. I just don’t want any part of that nonsense. I would recommend avoiding criminal campaigns until you and your players have a great deal of experience. As of now, I avoid them altogether.

Finally, there are tons of resources out there – use them! Bill Logan provided, in a previous Star Frontiersman article, an excellent bibliography. Use them for treatments, subsections, and events. However, remember that other people have read them too. Make sure you switch around characters, clues, outcomes, and throw in some additional red herrings to make sure some crazed sci-fi fan does not ruin your campaign. Come see us at the Star Frontiers forums and join the discussion. Current events are also relevant – Star Frontiers society is not as far from our own as you might think. Watch the media outfits and try to fit their journalistic stories into your Star Frontiers campaigns. You’d be surprised at the ideas that materialize.

In Star Frontiers, remember that story reigns supreme. Your preparation, using the techniques in this article and others, will be the key to having your players cry tears of joy and sorrow. When you have achieved that, then you will have become a great referee. Your players, and you, will remember your campaign for years to come.

SPAWN OF ZEBULON

By R. Kevin Smoot

Editor's Note: R. Kevin Smoot and his wife are proud of the birth of their new baby girl, born Sept 17 at 10pm MST. She weighed in at 8 lbs, was 20.5 inches in length, and is in absolutely perfect health. As of the time of this article, he hasn't yet let me know the name of the little angel, but he passed around virtual cigars in the forums at www.starfrontiers.us - stop by and congratulate him with us!

LEGACY OF THE EORNA

The following race description assumes that the events of 'The Voltornus Adventure' were successfully resolved, and some several years have since past. In addition to the Mechanon expansion into space, other races of Voltornus have also ventured out.

KURABANDA

Although the monkey-like race called the Kurabanda was discovered at roughly the same time as the other races that were genetically modified by the Eorna, they remain a rarity among the population groups elsewhere in the Frontier. Their strong family and tribal connections have thus far remained intact, and only the occasional outcast, banished from their society, has been encountered off of their home world in the Zebulon system.

PHYSICAL STRUCTURE

A Kurabanda stands 1.2 meters tall and looks somewhat like a tarsier monkey. It has large round eyes and large pointed moveable ears. It can swivel its head around and look behind its back. A Kurabanda's hands and feet, which have 6 digits each, have special pads for better grasping. These pads are filled with blood storage vessels, and permit more blood to be kept in the fingers and toes, allowing for a better grip than any Human could manage, since the muscles are less subject to fatigue. A Kurabanda's tail is prehensile and useful for climbing and holding objects, but it is not dexterous enough to actually manipulate tools or weapons. Due to similarities in body structure and build, most Frontier equipment can be easily adapted for a Kurabanda to use.

In the course of evolution, Kurabanda have lost some of the heavy fur that originally covered their bodies. A Kurabanda's torso is covered with fur, but its head, hands, feet and tail are bare. Its arms and legs are covered with fine hair that looks like soft down.

Kurabanda are omnivorous hunters. Their diet consists of meats acquired through hunting endeavors, supplemented by fruits and leafy vegetation.

SENSES

Kurabanda senses of taste, smell, and sight are roughly equivalent to a human's senses. Their sense of hearing also equals a human's, albeit in slightly different ranges. They have less acuity with low frequency pitches and a little more in the higher pitch ranges.

Although nerve receptors in Kurabanda skin are no more sensitive than other mammalian race, the sense of touch in their hands (and lesser degree feet) is remarkable. Even in total darkness, their tactile sense can give them a decent mental image of items and materials within their individual proximity as long as they have the option of feeling around. A Kurabanda can even feel the difference between a blank piece of paper and that with printing or ink upon it, although reading such would still be beyond their ability. This advanced tactile sense greatly aids the Kurabanda while climbing.

SPEECH

Kurabanda speech is produced in a similar manner to other mammalian races. Air is forced from their lungs through a series of moveable tissues in their equivalent of a larynx (voice box). This verbal communication is enhanced by complex facial expressions and gestures.

The native spoken language of the Kurabanda is not overly expressive, but most concepts can be expressed in a purely verbal or written manner. However, it is the body language and facial expressions that make for meaningful discussions among the Kurabanda, as their body language and expressive faces convey a wealth of inflection and emotional content.

Surprisingly the Kurabanda have a very strong grasp of mathematics. However, because they have six digits on each hand (and feet), their arithmetic is based upon a base-12 system. They can do many complex arithmetic problems in their head, but they tend to forget that most other races do not understand differing counting systems. Thankfully, most polyvoxes are programmed with algorithms that can convert the numbering systems automatically. Without the aid of translation programs, standard communication will often be riddled with numerical errors when those concepts are discussed (counts, distances, computations, etc.).

SOCIETY AND CUSTOMS

Kurabanda are a peculiar race in the Frontier. Most races that encounter the other Frontier races and the technology that accompanies them tend to embrace the new interplanetary culture. Kurabanda, as a whole, have rejected the societies of the Frontier. They are definitely not xenophobic; as they rather enjoy and celebrate the differences of any off-world visitors they might receive. It is simply that the resilient Kurabanda culture remains strongly devoted to family, clan, and their territories, despite contact with Frontier emissaries and the cultures they bring.

All Kurabanda are natural practical jokers. They find great delight in watching minor mishaps and watching others being surprised or shocked with the elaborate jokes one can imagine. A Kurabanda will go to great lengths to engineer these jokes, but the best surprises are the ones that occur without engineering. It is common to see a Kurabanda literally rolling on the floor in laughter after witnessing another slip and fall.

Kurabanda on Volturnus: In Kurabanda society, when one Kurabanda is harmed, his or her entire family has been insulted. Blood feuds are not common, but do occur. To avoid feuds it is usually necessary to pay compensation to the injured parties. Clan blood feuds can also be avoided by a system of ritualized vengeance. The vengeance is aimed at forcing the victim to lose prestige. Kurabanda constantly try to outdo each other with showy displays of wealth. A family will put on an incredibly lavish feast to honor its ancestors and show its neighbors how successful the family is. Occasionally, the feast may be part of ritualized vengeance. A guest of honor may actually be mocked by an excessive display of wealth. It is difficult for outsiders to tell the difference between mocking a guest of honor and honoring the guest, but Kurabanda always know. An insulted guest can take revenge at the feast by presenting the host with even more lavish gifts. A blood feud can also be declared at a later time.

Generally, Kurabanda hold physical prowess and the glory of dangerous exploits as ideals. Their value system is based on the

perceived image of honor. A respected Kurabanda is one who is a good hunter, a good fighter, and an individual who upholds the honor of the family. A Kurabanda who does not hold to these ideals or who does not take revenge for an insult is disgraced in the eyes of his family and his clan and often banished or self-exiled. Since most Kurabanda do not travel away from their tribal lands, it is these disgraced Kurabanda individuals who are encountered elsewhere in Frontier space.

On Volturnus, most Kurabanda live in bachanda tree forests, although with the arrival of the Frontier and small bits of modern amenities introduced into their lifestyles, many Kurabanda have spread to new areas and new types of terrain. As a whole, Kurabanda love to hunt, and they tend to live in areas that offer a variety of hunting experiences to them. With the arrival of Frontier technology, the Kurabanda have expanding their hunting endeavors to include new techniques. One of their favorites is to hunt from the vantage offered by a glijet or a mini-copter.

Modern Kurabanda live in a variety of home types depending on the terrain, but most prefer to live in tree top villages. Although more modern building materials are used in the construction, the villages generally consist of a number of large houses interconnected by series of walkways elevated far off of the ground level. Each house is that of a different extended family. Also in the village are the men's buildings and women's building, which are special structures for one or the other sex. These two types of buildings are something like clubhouses for each sex, and serve as places of relaxation outside the home.

Kurabanda society is based on the family and kinship. Without understanding the importance of family ties, one cannot understand Kurabanda society. An individual's family relationship also defines that individual's rights and duties. Kin terms are exact. Instead of "cousin" a Kurabanda has Father's Brother's Sons, Mother's Brother's Daughters, etc. Each relationship is somewhat different. For example, a man could count on his



Father's Brother's Sons to stand by him in battle but he could only count on his Mother's Brother's Sons for a small amount of financial support in times of extreme emergency.

The basic kin group is the extended family. An extended family would include a patriarch and his kin. A patriarch is usually the oldest married male. Living with him would be his wives, their adult sons, the sons' wives, the adult grandsons, the grandsons' wives, all unmarried adult daughters, and all the children of the various marriages. An extended family averages 20-40 people, but could range from 10 to 100 individuals. A patriarch can order the family to be divided if the number or people living in his household become too large.

The next most important group is the clan. A clan is all the extended families with the same last name. All members of the clan are descendants of the one who gave his name to the clan. The actual descent is sometimes hard to trace since the clan founder is sometimes a mythical individual directly related to the gods.

Kurabanda who live in a particular region form a region government called a tribe. The final organization is that of the Kurabanda people, who are all descended from Kurabanda, "The First Ancestor". The Kurabanda have not yet formed any nation sized or planet-wide governments of their own.

Kurabanda have a strong sense of territoriality. The hunting area belongs to the tribe and other tribes may not trespass. Each clan and extended family also has smaller hunting territories inside the Tribe's territory. One of the most prevalent types of cases in court is a suit involving boundaries between hunting territories.

Kurabanda trace their ancestry through the male line and all children have their father's last names. Married sons remain in the household of their father while married daughters join the households of their husband's fathers. It is illegal for anyone to marry a member of the same clan. A male may have as many wives as he can support. In fact, a male's social standing increases if he has many wives, but it is a great dishonor to have more wives than can be supported.

Kurabanda marriages are not seen as primarily a love relationship between two individuals, but as an alliance between two families. The goods that are exchanged before a marriage ceremony are gestures of good faith on the part of both families.

Despite the rather formal method by which marriages are arranged, the concept of love is not unknown to the Kurabanda. In fact, a common theme throughout Kurabanda literature involves two lovers defying their families in order to remain together. Many long-running feuds have such situations at their roots.

Tribal chiefs and councils of elders run Kurabanda society, but modern times and contemporary ideals

have modified how the individuals are chosen. The individuals are generally elected through mostly democratic means, although it is still common to find corruption and political engineering in play during the elections. The chief forms the equivalent of the executive branch while the council of elders forms a more judiciary body. Since each patriarch runs his family, and most tribes are not excessively large, the laws of Kurabanda society are decided by general election and not by a legislative branch of government. The laws are generally based on tradition and custom.

Modern Kurabanda do not practice much religion in the normal sense. They are more concerned with ancestry adoration and living up to the honorable ideals set forth by their forebears. Each Kurabanda home still includes some sort of shrine to pay respects to their ancestors' spirits. Large formal shrines are kept in the patriarch's dwelling.

Kurabanda encountered elsewhere: A Kurabanda encountered away from Volturnus is most often a disgraced or dishonored individual who is not very welcome in their own tribe. These Kurabanda still hold the ideals of honor and duty in high regard. Without the kinship of their own families, they often turn to new groups of friends to bond with, regardless of race. They treat the new 'family' with all the same endearments and quickly take offense when one of their new kin is slighted. To the dismay of their new friends, their love of practical jokes also remains intact.

Kurabanda who explore the stars are most often involved in environmental endeavors, as their love of outdoors and hunting tends to remain intact. Many Kurabanda have also become renown for their exploits as bounty hunters. Also there is a Kurabanda with some amount of fame who endorses environment and animal concerns on New Pale as the 'Dino Hunter'.

ATTITUDES

In general, the Kurabanda like the other Frontier races. Attitudes and behavior that will be likely to cause an unfriendly reaction in the Kurabanda include poor sportsmanship, an angry reaction to a practical joke, declining to accept a gift, and giving a valuable gift to a Kurabanda without allowing the individual a good enough chance to pay it back.

Physical similarities make Yazirians well received, and also to humans to a lesser degree. The Dralasite share the Kurabanda's rather over-developed sense of humor, so the two races get along quite well. The Vrusk seem quite alien to the Kurabanda, and the Kurabanda are often quite suspicious of them. The Vrusk don't seem to care much for individual Kurabanda but can appreciate their honorable ways when the Kurabanda fixate their kinship attitudes to a Vrusk corporation.

Sathar (and Sathar-like races such as the S'sessu) are universally disliked. This is most likely a remnant of the Eorna manipulations of their genetic code. The mere presence of a Sathar is likely to cause aggressive behavior in a Kurabanda.

Kurabanda reactions can be modified greatly when dealing with their clan or family, whether this association is by blood or a disgraced Kurabanda's adoptive 'family'. Known rivals of their 'family' are equally likely to have extreme reactions generated.

SPECIAL ABILITIES

Mental Shield (10%) - Due to the influence of the Eorna, Kurabanda are completely immune to Sathar mental influence. In addition, any other mental control, attack, intrusion, reading of thoughts, or similar condition is less likely to succeed on a Kurabanda. All Kurabanda begin with a 10% resistance to such attempts, and the spending of experience points may further increase this number. The Mental Shield rating is applied as a bonus to any resistance check (such as LOG scores), or is applied as a flat chance to resist any ability that has no associated check for resistance.

Climbing - Kurabanda characters may climb with an additional +10% bonus to any climb related check (per Alpha Dawn rules, normally a STR check at +30 done at the halfway point and the top of a climb. Automatic Failure only occurs on a roll of 00 (normally 96-00). Additionally Kurabanda may move at 5m while climbing, and may also move at this rate laterally in a hand over hand manner (with assists from prehensile tail) while in densely forested areas or areas with similar conditions of handholds and protrusions.

KURABANDA CHARACTERS

Characteristics

| | |
|----------------------------|--------------------------|
| Average Size | 1.2 meters tall |
| Average Mass | 45 kilograms |
| Average Lifespan | 120 years |
| Reproductive System | heterosexual, viviparous |
| Body Temperature | 38 degrees Celsius |

Ability Scores

| | |
|----------------|----|
| STR/STA | +0 |
| DEX/RS | +5 |
| INT/LOG | +0 |
| PER/LDR | +5 |

Movement

| | |
|----------------|--------------------|
| Walking | 10 meters per turn |
| Running | 30 meters per turn |
| Hourly | 4 kilometers/hour |

Special Abilities

| | |
|----------------------|--|
| Mental Shield | 10% resistance to mental control, attack, intrusion, etc. Can be increased. Immune to Sathar mental influence. |
| Climbing | Climbing rate of 5m per turn; Climbing checks at +10% with automatic fail on 99-00 only. |



Author's Note: Much material was taken from pre-existing material. A few liberties were taken to roughly balance Kurabanda against the other frontier races (i.e. Mental Shield), and to update their cultural development after the arrival of the Frontier races.

CINEMATIC ACTION

By Andrew Modro

WOUNDS AND MORALE

Thanks to Hollywood and many other role-playing games, we often expect that most wounds inflicted by weapons such as firearms will result in an instant, one-hit kill. In truth, however, death from wounds most often comes from blood loss and infection, with shock or a hit to a major organ such as the brain or heart causing only a small percentage of "instant" deaths.

The weapon damage rules of STAR FRONTIERS actually closely reflect this reality. A standard auto loading slug thrower pistol does, on average, 11 points of damage to an undefended target. Considering that the "average" STA total for an average, non-hero character in Alpha Dawn games will be about 35, this is far from enough to drop an enemy in one shot. Even a maximum damage total of 20 isn't enough to "instantly" kill a foe.

What is missing from this system are the reactions a wounded NPC will have when hit. 11 damage to an NPC with 35 STA is a little less than one third of her full STA total. In truth, a wound this damaging will cause severe pain, which will impact the NPC's actions. Depending on the NPC's perseverance, a wounded non-player character may surrender, flee or even drop to the ground and writhe in agony rather than continue to fight, and even if he does continue to fight, his performance may be affected.

Referees who would like to have some concrete guidelines reflecting the effects of pain and shock from wounds can consider the following optional rule to add to their Alpha Dawn games:

Morale Checks From Wounding: NPCs who have been reduced to less than half their maximum STA totals by wounds make a check to see if they are

Author's Note: The STAR FRONTIERS rules do not include a specific stat for "willpower". This optional rule allows a referee to decide what better represents the willpower of an NPC. The choice of LOG is based more on reason and logic, meaning the character's willpower is based on rational thought. The choice of LDR draws on the link between natural leadership and force of will. The choice is up to the referee, though the choice should be consistent throughout the campaign.

still willing to fight. This is a simple roll against the either of the character's LOG ability score or LDR ability score, at the choice of the referee.

A success means the NPC will continue to fight, or will make an organized retreat if the odds are obviously overwhelming. Failure means the NPC will flee, surrender or be rendered effectively incapacitated and unable to continue fighting by the pain of his wounds.

CINEMATIC AMMUNITION

Even in grittier science fiction, heroes rarely find themselves running out of ammunition unless it is dramatically appropriate. STAR FRONTIERS is strangely nitpicky about ammunition, given its "rules-light" approach. The following optional rule changes this, giving Alpha Dawn firefights a feel more like blaster shootouts in Star Wars or Babylon 5.

"Out Of Ammo" Failures: Heroes do not need to track ammunition or SEU charges for any weapon which holds more than one shot. They are assumed to be carrying enough extra ammo and competent enough at reloading to be able to continue fighting without interruption. The only time ammunition shortage becomes relevant is when the hero rolls an unmodified "00" on an attack. This means the hero's weapon has no more ammunition loaded, and the hero is caught unaware of this fact. The hero must take a turn to reload as usual. After this reload, if a second unmodified "00" is rolled, the character did not reload properly and the weapon is jammed/blocked/otherwise unusable until the character is able to spend some time fixing the botched load.

In any case, the character is immune to further "out of ammo" failures for a minimum number of five (5) turns. Characters are assumed to begin a session with weapons that are freshly loaded, meaning they may have the five turns of "immunity".

At any time, the referee may rule that the character's weapon needs to be reloaded.

Cinematic Screen Defenses: Defensive screens use energy charges much like weapons, and are often linked to the same power source (belt packs and backpacks). In regular Alpha Dawn games, this leads to the same micromanagement problem as

weapon ammunition. Removing the energy use of defenses vastly increases their power against weapons with limited shots, but that increase is commensurate with cinematic ammunition -- so long as the defenses can, eventually, be overcome. This optional rule, designed to be used in conjunction with the above ammunition rule, changes how defenses function in terms of power upkeep.

Rather than consuming a specific number of SEU per hit or per time unit, most defenses that use SEU (screens) now have a success number that is checked each time the character is hit. The roll is, effectively, a check to see if the screen can defend against the attack and continue to function properly. If the roll is equal to or below the success number, the defense functions as normal. If the roll is above the success number, the screen fails to function because it is out of power, and will not function again until it is recharged. Albedo, gauss and sonic screens have a base success number of 60. Inertia screens have a base success number of 75. Holo screens are not affected, because they do not function the same way as the others.

Similar to a weapon reload, a screen defense that has been recharged is immune to being "out of power" for a minimum number of three (3) hits. Characters are assumed to begin a session of play with freshly-charged defenses, which means they have the three turns of "immunity".

CINEMATIC HENCHMEN

Henchmen. Hirelings. Lackeys. Mooks. Villains in heroic fiction often maintain hordes of faceless, almost useless underlings that they throw at heroes in waves, hoping to slow down the good guys and maybe score a lucky hit. These unfortunate thugs are usually dropped in one blow by the heroes, serving more as ammunition sponges than actual obstacles.

In Issue #04 of the Star Frontiersman, Bill Logan presented ten excellent rules for henchmen. However, these rules still treat "mooks" as marked-down characters with the possibility for individuality. The optional rules presented here treat henchmen as faceless elements, allowing the referee to throw them at the heroes in groups with minimal prep and bookkeeping.

One-Hit Kills: Mooks go down in one hit, regardless of the damage from the hero's attack.

Mob Scene: Henchmen rarely appear alone, otherwise they'd have full stats. Instead, mooks attack in mobs, hoping to use numbers to make up

for their deficiencies. A "mob" of henchmen will have a Threat Rating of 1 to 6, depending on how many there are, how heavily they're armed, and if they have had any actual combat training. A Threat of 1 represents a couple unarmed mooks; a Threat of 6 is a squad of trained soldiers with military weapons and perhaps even a gyrojet rifle or heavy weapon.

A mob's Threat Rating serves as the base for all its skill and ability score checks. Simply consult the Mob Threat Rating Table, and use the indicated number for all rolls, such as attacks and STA checks.

MOB THREAT RATING TABLE

| THREAT | TARGET |
|--------|--------|
| 1 | 30% |
| 2 | 35% |
| 3 | 40% |
| 4 | 45% |
| 5 | 50% |
| 6 | 55% |

Determining the Threat Rating for a mob of henchmen is mostly "eyeballing". Greater numbers, heavier weapons, defenses and advantageous special circumstances will all increase the Threat Rating of a mob, but only so far. Twenty unarmed thugs are still very little threat to a party of six heavily-armed heroes, for example.

A good "rule of thumb" regarding Threat Rating is to compare the Threat to the characters' skill levels. Characters with skills (especially combat skills) equal to or above the Threat Rating should be able to easily handle the mob. Characters with skills lower than the mob's Threat will have a more difficult time.

Cinematic Upgrade: If a henchman survives an encounter with the heroes and escapes, he can always return later as an individual character with more fleshed-out stats. One idea could be to upgrade the mook to Bill Logan's henchman rules, and if he survives again, to "promote" him further to full stats. This will give flavor to those random, surprising standouts who sometimes get very lucky.

Editor's Note: Before writing this article, Andrew dropped me an email and asked if I'd be offended if his article took a different take on henchmen than the stuff I wrote in Issue #4. This actually made me smile – because it means someone read the article – and it made them think... spawning yet more creativity.

It's important for everyone to realize that NOTHING presented in this webzine is published with the intent to claim legitimacy. This is not official content – and anything you see here is one man's (or a few people's) opinion, and nothing more.

If you read something and have a different take – I invite you to please share that opinion with everyone else! This webzine is all about sharing our collective pool of talent.

EQUIPMENT

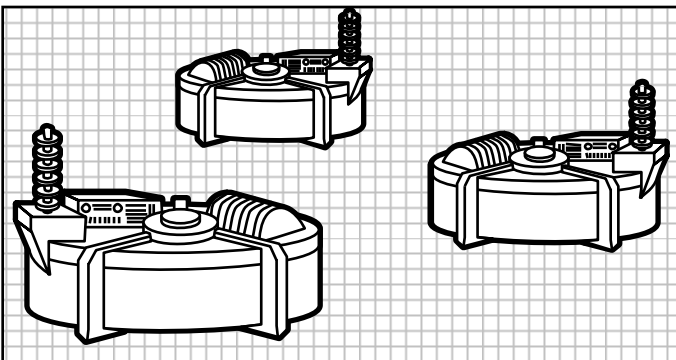

EMP FIELD GRENADES

By Bill Logan

More mine (or bomb?) than grenade, the E.M.P. (Electro-Magnetic Pulse) field grenades are designed by and for military use. They are prohibitively expensive to all but the most wealthy adventurer – but having a pack of these could mean the difference between life and death when facing robotic or computer-augmented enemies.

Purchasing an EMP Field Grenade actually provides you with a special carrying pack containing three identical-looking field grenades. They are not used separately (alone they're simply useless).

To use an EMP Field Grenade pack, you must place the field grenades anywhere from 5 meters to 15 meters apart. All three must be placed to define a triangular-shaped field where the EMP effect will take place. When placing one of the grenades, it must be activated with a small series of controls to tell it how far away each of the other grenade disks are placed. This procedure is not as difficult as it sounds, but it's not as fast as pulling a pin and hurling other types of grenades. It takes one character one turn to set a grenade (thus a party of 3 can do it in a single turn). Once all three grenades are placed and taught, the EMP Field is set and ready for detonation. Detonating the EMP Field is done in one of two ways: voice command or purposeful activation.

Voice Command. If the last of the three grenade-disks is set for voice command, the character who activates it speaks a word while she sets it. This will be the command word to detonate the field. If she speaks that word again within 10 meters of a grenade, detonation occurs.

Purposeful Activation. Whether or not a command word was spoken during final grenade activation, anyone can detonate the field by simply slamming their hand (or an object) down on a button located in the center of any of the grenades.

When the field detonates, all electronic items caught within the triangular-shaped field will be struck with an intense electro-magnetic pulse field that will cause it to be rendered inert, disabled, and difficult to repair. The field is harmless to living beings.

Summary: EMP Field Grenade packs cost 750 Credits and weighs 1kg for the shoulder-slung pack and its contents.

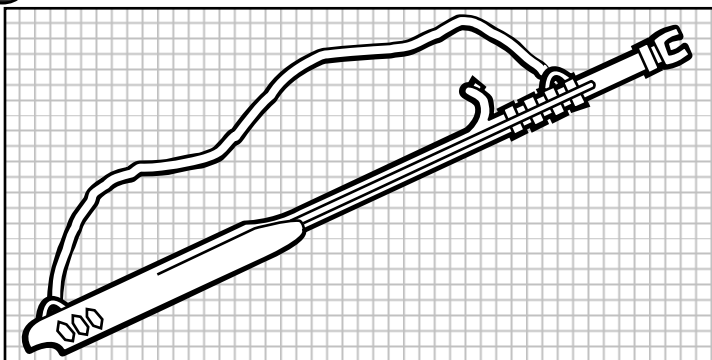

DEFENSE ROD

By Noah Logan

In some places in the Frontier, security guards aren't given blasters or electrostunners. They're equipped with the Defense Rod – an intimidating invention from Wartech that finds more non-military use than military.

It's a staff-length device that has a slingstrap worn over the shoulder. A simple curved handle gives a place to grip – and has a simple trigger. Pressing the trigger causes an electric arc to manifest between the two metal parts at the rod's end (an electrode and a probe). This electric arc makes a crackling noise that literally raises the hairs on the necks and arms of living beings within a short radius (1 meter).

If the Defense Rod makes contact with an enemy (normal to-hit roll), that individual must make a current Stamina check or fall unconscious for d100 turns, much like the effect from an electrostunner. When used in this way, each stun attack drains 2 SEU from the weapon's 20-SEU PowerClip. An Anti-Shock Implant immunizes someone from this effect.

A second series of three buttons also exists at the base of the Defense Rod. These represent release buttons for three separate channels of special fuel cells. When one of these buttons is pressed, it spews the contents of that channel's fuel out of the front of the rod, passing through the electric arc and igniting. This causes a flame-thrower effect that is far more damaging than the simple stun effect the Defense Rod is normally used for.

The fuel cell channels can be released one at a time (thus providing three uses of flame-throwing deadliness) or can be released simultaneously, coupling the effects.

The flame-thrower effect causes 3d10 damage in the first turn in which its fuel strikes its target. In the turn after, it causes 2d10. In the third round it causes 1d10 damage. It burns itself out in the fourth turn. If two channels are used, the damage will be 5d10/3d10/1d10. If all three channels are used at once, the damage will be 7d10/4d10/1d10.

Summary: Defense Rods cost 500Cr and weigh 2kg. The specialized fuel channels can be refilled. Each channel costs 25Cr. The stun effect uses standard 20-SEU PowerClip, or can be connected to a Power Backpack or BeltPack. The stun effect uses the wielder's Melee Weapons skill. Firing the flame thrower uses the wielder's Projectile Weapons skill.

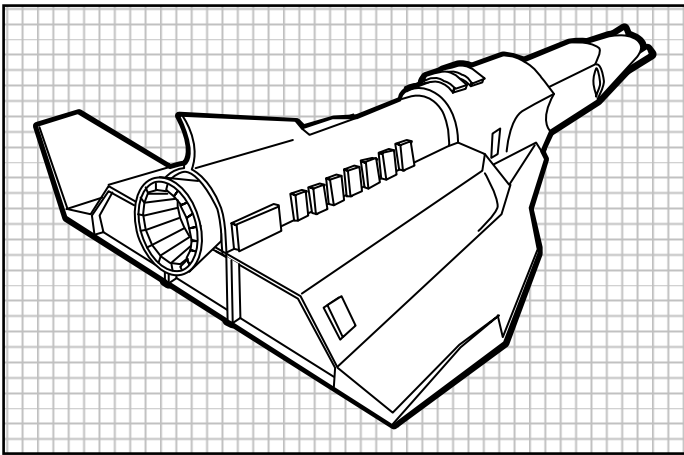

PERSONAL RUNABOUT

By Bill Logan

Author's Note: I've used this in my games for a long time, and though it's not strictly compatible with Knight Hawks, it serves an important but missing role in Alpha Dawn games. All of the math here is derived from the Alpha Dawn book. The only assumption made by me is the amount of energy required for 1LY of travel. Whether or not there is artificial gravity or food or whatnot is all abstracted, just like it was in Alpha Dawn.

The Alpha Dawn Expanded game has rules for covering all manner of ground and air vehicles. If your characters need to get from star system to star system, there really seems to be only two solutions: book passage on a starliner, or buy Knight Hawks and build a ship.

The vehicle presented here is a missing-link alternative to those two options. It's a small shuttle capable of entering orbit, flying around like an aircar, and short interstellar trips. It's a runabout – and it's available to wealthy travelers and adventurers who don't like public transportation or who need to live life off-the-grid.

Speed. Substantially less expensive than a starship, it travels at a rate of 1 LY per two days (using the Alpha Dawn methodology of star travel). Thus a trip from Araks to Athor would take 16 days from port to port.

Range. The vessel is not capable of sustaining life support or operating its engines past 20 days of continuous operation. Therefore, it is not possible to take a voyage beyond 10LY distance. For this reason, you will not find Personal Runabouts in systems like Lynchpin whose nearest neighbor is 14 Light Years away.

Power. The Personal Runabout uses a Type 2 Power Generator. Operating and maintaining any type 2 generator requires a cost of 200Cr per day of use. The generator creates 1,000 SEU (we'll call that 1kSEU) per hour (that's 20kSEU per day). The Runabout consumes 40kSEU to travel 1 LY, which amounts to two days worth of constant generator output. Therefore, it costs 400Cr per LY traveled for generator fuel and maintenance consumables. The maximum cargo capacity for fuel and consumables is 400kSEU (10LY distance, a total cost of 4,000Cr to "fill 'er up" from empty... 10Cr per 1kSEU).

Additionally, the engine compartment has 2 type 4 parabatteries (a total capacity of 8kSEU). These allow for travel within an atmosphere, at a speed and range equal

to that of an aircar. Because of the added mass, it uses these two parabatteries at the same rate an aircar would normally use its one. A runabout normally has a range of 1,000 km on its 8kSEU supply, meaning it drains 1kSEU from the parabatteries every 125km.

The power generator can recharge the parabatteries in 8 hours but this drains 8kSEU from the remaining power.

Damage Capacity: If shot at, it uses the same rules as would an aircar while in an atmosphere. If it is hit in space, it will be destroyed with 1 hull point worth of damage. Its small size allows it to dock on other ships (in Knight Hawks rules, any ship of hull size 5 or greater) and refuel there, or on space stations.

Crew & Cargo: In Alpha Dawn rules, the Personal Runabout is treated like an aircar while in atmosphere, and like a slow-speed starliner while in space. It has a maximum crew capacity of 6 passengers, and enough cargo space for 2,000kg (up to 4 cubic meters) of additional equipment (not counting fuel and generator consumables, detailed above).

Example: Gruno Trel has a price on his head, and doesn't trust anyone to supply him with an illegal ID. He has the money and so purchases a Runabout for just under half-a-million credits. It has room to bring along up to five of his buddies, and carry around most of his possessions in its cargo compartment.

He fuels up for a long voyage, filling up the Runabout's fuel compartment at a cost of 4,000Cr. This give him 400kSEU of power. He takes a trip from Prenalgar to Dixon's Star (a 5 LY voyage). The trip takes 10 days and drains (40x5=) 200kSEU from his supply. He has 200kSEU remaining.

He then has a long-range adventure on Laco (an outpost planet in Dixon's Star) where he travelled 300km in-atmosphere. This drains his parabatteries around 3kSEU (1kSEU per 125km) leaving his parabatteries at 5kSEU.

Gruno spends 3 hours recharging his parabatteries while he sleeps, which drains his main generator's supply by 3kSEU. His main supply is now at 197kSEU. He needs to refuel before his return trip to Prenalgar.

Gruno refuels his generator supply for the return trip. He goes to any shop that sells power generator supplies and fuels. Since he wants to fill up his Runabout, he notes that he is currently (400kSEU - 197kSEU =) 203kSEU short. This costs him 2,030Cr.

Fuelled and ready, Gruno takes off and heads back to Prenalgar to collect his payment for his mission on Laco. He calculates his expenses and realizes he better ask for more money from his employer... the trip cost him 4,030Cr in fuel and supplies, not to mention ammunition and other costs.

Summary: A Personal Runabout costs 550,000Cr and includes a type 2 generator and two type 4 parabatteries, without fuel. In atmosphere, consider it just an oversized aircar. In space, it travels 1LY per 2 days. Fuel for the generator is 10Cr per 1kSEU. It requires 40kSEU to travel 1LY. Max capacity 400kSEU.

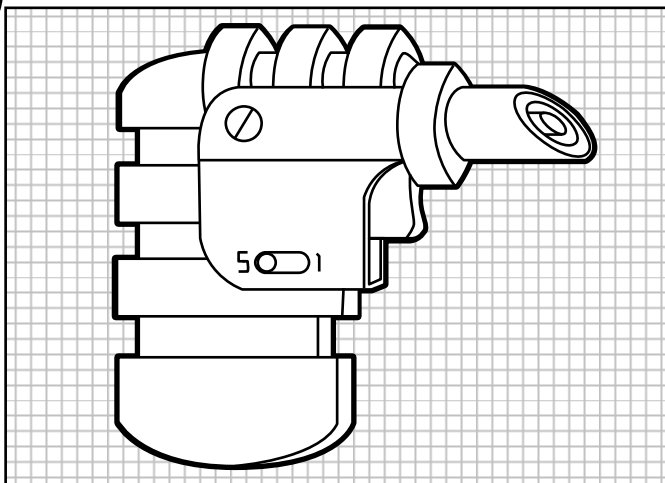

TIZZLE LASER

By Brian Conway

Outer Reach's only contribution to Frontier technology: the infamous Tizzle Laser. This is a very small (smaller than the average hand) laser pistol.

It has 2 SEU settings: 1 and 5. A setting of 1 drains 1 SEU and causes 1d10 damage. A setting of 5 drains 5 SEU and causes 5d10 damage. It only fits powerclips - there are no ports for larger powerpacks. It can function in a vacuum. The powerclip is bigger than the rest of the pistol - that's how small this weapon is. It fires two shots per turn.

Standard Ranges are:

Point Blank: 0 to 3 meters
Short: 3 to 8 meters
Medium: 8 to 15 meters

The weapon does not shoot past medium range. The beam diffuses harmlessly past 15 m - it might hurt a little and burn a hole in your shirt, but does no significant damage.

This weapon is illegal in almost every area of the Frontier, particularly Outer Reach, because of the ease with which it may be concealed. It is a favorite of pirates, murderers, thieves, and assassins all around the Known Galaxy. No one knows actually who invented this weapon other than it definitely is from someplace in Outer Reach. It is produced in limited numbers because the weapons tend to fall into the hands of the Opposition forces that the Outer Reach governments are trying to stamp out.

Pricing this weapon is difficult - it usually costs about 300-500 credits on Outer Reach but is much rarer on the worlds where it is illegal. Certain black markets have priced Tizzles at 3000 credits or more.

An attempt of a legitimate sale would of course result in the immediate arrest and imprisonment of the seller.

Editor's Note: To effectively represent the illegality of this weapon, Referees may allow characters a +25% chance at any roll to palm or hide a Tizzle Laser.

Summary: Tizzle Lasers cost anywhere from 300-3000Cr but must be purchased on the black market. Weight negligible; Range 3/8/15/--/--; Rate 2/turn; damage 1d10 or 5d10; Defense Albedo; Energy/Ammo: each shot drains 1SEU or 5SEU, uses normal 20 SEU PowerClips.

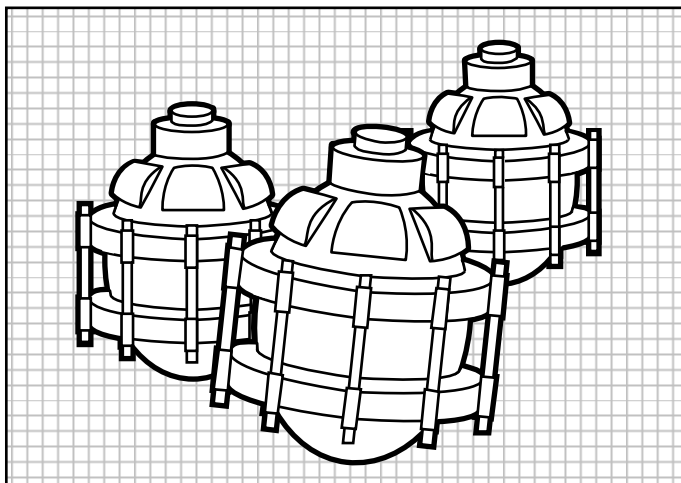

STUN GRENADES

By Brian Conway

Another addition to the non-lethal arsenal: the Stun Grenade. This device causes a concussive blast which can cause confusion or more. When successfully thrown at a target, the stun grenade can have two effects, based upon the target's STA check. The grenade has two blast radii - one that is two meters in diameter, and one that is five meters in diameter.

The blast expands the air molecules in the blast radius, then the air collapses in on itself at an alarming rate, causing a sudden clap of thunder that can be heard for miles. The blast can shatter standard (non-reinforced) glass and knock leaves off trees, but is generally only able to stun or daze an opponent.

Those within the first blast radius must make a STA check. If they fail, they are knocked back 1 meter from the blast, and are knocked unconscious for 1d10 turns from the concussive trauma. Use the grenade bounce diagram for the direction of the knock back. If the number indicates the target will knock back in the direction from which the stun grenade was thrown, then either roll again on the Grenade Bounce Diagram until another direction is determined, or assume the grenade landed just beyond the target, centering the concussive blast behind him. No damage is taken.

Those within the 5 meter blast radius must make a STA check or be dazed. A dazed character has all of his ability scores halved (rounded down) for 1d10 turns. This will affect their IM and PS levels as well. No damage is inflicted, but the character's halved STA will mean it won't take much to knock him unconscious. Targets which pass the STA check are unaffected by the blast.

Defenses: Inertia screens and skinsuits help cushion the wearer from the kinetic shock of the concussive blast. Each of these provides a bonus of +20 to the wearer's STA check. If both defenses are present, the bonus is +40. The Stun Grenade is ineffective in a vacuum, and can have its blast radius increased or decreased based on air pressure and density.

Summary: Within 2 meters of the blast, all living beings must make a STA check or be thrown prone and unconscious for 1d10 turns. Within 5 meters, living beings must make a STA check or be dazed 110 turns. Each inertial defense provides +20 to STA check. Cost 75 credits, weight negligible.

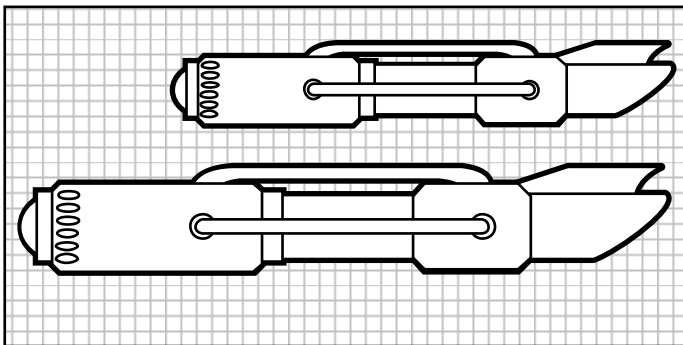

PION ENGINES

By William Signs

Editor's Note: The StarFrontiersman webzine seldom has content from the Knight Hawks game system (an expansion for the Alpha Dawn boxed set). But there is no reason to exclude these excellent rules. This submission provides a new item for use with either the tactical boardgame or the role-playing supplement. Please send in any KH submissions!

Developed by the Mhnome during the Second Sathar War, antimatter pion engines generate power and thrust through a matter/antimatter reaction.

A pion engine uses liquid hydrogen fuel, subjected to X-ray bombardment in the bombardment chamber, the resulting liquid antihydrogen fuel being siphoned off and injected into the primary reaction chamber along with the remaining liquid hydrogen fuel, the resulting explosion energizing thermopiles lining the chamber, with the pions generated from the matter/antimatter reaction directed through the exhaust chamber by magnetic coils which compress the pion stream to generate a higher specific impulse than would be possible with other engine designs.

Pion engines cost twice as much as atomic engines of the same size. Ships with pion engines have an ADF one point higher than ships equipped with atomic engines.

EXAMPLE: A hull size 4 ship with two size A atomic engines has an ADF and an MR of 4, according to the Hull Size Specification Chart given in the Knight Hawks rules. If the owner decides to replace the atomic drives with size A antimatter pion engines, then the ship's ADF increases to 5, while the MR remains 4.

Bigger Engines For Smaller

Any two engines can be switched out for a single engine of the next larger size.

EXAMPLE: The ship above can easily switch out its two size A engines for a single size B engine.

Summary: The pion engines cost twice as much as normal atomic drives, but provide a ship a bonus of +1 to its Acceleration/Deceleration Factor (ADF). Unlike atomic engines, two small engines can be exchanged for one larger engine.

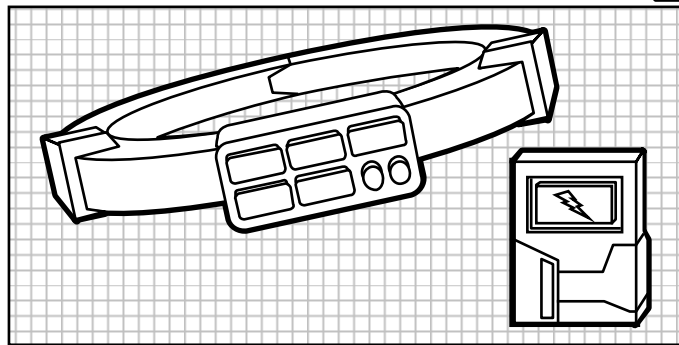

BOUNTY SHACKLES

By Stephanie Logan

All the rage in the bounty hunting community, even Star Law finds this device helpful when transporting prisoners in observance of jurisdiction rules. More a collar than a traditional shackle, a criminal is fitted with a circular device around his neck. It fits sufficiently comfortably.

The bounty hunter or Star Law agent who fits the device around the criminal then activates it with a unique code using the colored buttons on the front of the collar. He then touches his hand-held Key to the collar and presses the sole button on it. The shackle is now set.

While set, the criminal cannot move more than 5 meters from the Key. Doing so will activate the collar. If performing actions that warrant it, the holder of the Key (presumably the one who set it!) can press the sole button on it, which will activate the collar. Tampering with the buttons or the release mechanism on the back of the collar without repeating the activation/ deactivation code will activate the collar.

When the collar is activated, it sends a blast of high frequency sonic energy through the neck of the wearer, assaulting his central nervous system. The criminal must make a STA check or be brought to his knees in pain, gasping for consciousness, unable to do anything but writhe. It seems inhumane to onlookers, but the sonic signal is quite safe and cannot result in death. If the criminal passes his STA check, he can act through the pain for one turn with a -15 to any actions, but next turn if the Key holder is still pressing the button, the process will repeat. The stun effect is self-contained. If the criminal touches another person, the effect is not transferred. *Warning to novice bounty hunters: A sonic screen will prevent the stun from functioning.*

Star Law offices have master Keys that will release any collar. It is rumored that master Keys may have been reverse engineered by an obscure hacker on Triad, but this is unconfirmed. If found on the black market, its price would easily be more than 10,000Cr.

The collar stores 20 SEU, enough power to be activated 20 times before it is depleted. A depleted collar can be recharged at special Star Law locations for 10Cr per SEU. A Star Law or authorized Bounty Hunting license is required to purchase it, but local laws vary on how to obtain these. Being found with one of these devices without a license can be punishable in some systems, and having a master Key is certainly punishable on all.

Summary: A Shackle and Key costs 500Cr, weight is negligible. It stores 20SEU and can be recharged at 10Cr per SEU. Each stun drains 1 SEU.

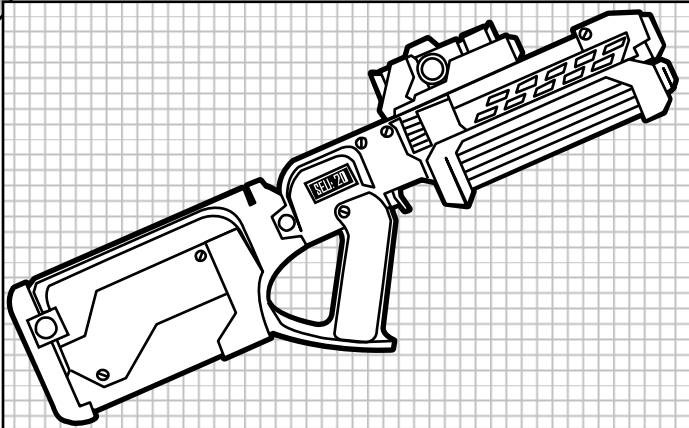

LASER AUTO RIFLE

By Samuel Schmead

The laser auto rifle is a rifle-sized firearm that shoots laser blasts at a high rate, allowing bursts of laser fire instead of the single beams projected from conventional laser pistols and rifles. It is a fully-automatic laser rifle.

The laser blasts projected from the laser auto rifle are small, quick blasts rather than the long, elegant beams of most laser weapons, but the higher rate of fire allows for bursts – which can sometimes help you hit a target, especially if they're behind partial cover.

Single Shots: The laser auto rifle cannot be switched between beam power settings. Each pulse does 1d10 points of laser damage, and the firer of the weapon can fire up to three of these pulses in a turn, each aimed independently.

Burst Fire: Alternatively, the weapon can fire a burst of 10 pulses, giving the shooter a +20 chance to hit and causing 5d10 points of laser damage on a successful hit. It can be aimed at up to five adjacent targets in a 10-meter wide area. Such an area burst causes a total of 5d10 points of damage plus 1d10 for every additional target after the first, divided among all targets in the area fired upon. Only one roll is needed to hit all the targets, but any negative modifiers that could apply to one target apply to the entire group.

For example: A mercenary sweeps an alley with a burst of laser pulse fire. There are four enemies in the alley, one of which has soft cover. The mercenary receives his +20 to hit because he's firing a burst. Since one of the targets has soft cover, all are considered to have it, so his chance to hit is modified by the Soft Cover modifier from the combat table (a penalty of -10). He succeeds in hitting. The mercenary's player rolls 8d10 for damage: 5d10 for the first target, plus 1d10 per additional target. He totals 46 points. Each target takes 11 points of damage (the remaining 2 points are lost).

Each shot fired expends 1 SEU from the weapon's power source. Therefore, single shots drain 1 SEU each, while bursts drain 10 SEU. Laser auto rifles use 20 SEU clips but can be attached to belpacks or powerpacks with a 1-meter power cord. An albedo suit or screen halves the damage from all lasers.

Summary: The laser auto rifle costs 750 Cr and weighs 3kg. ROF: 3(1), Damage: 1d10 each or 5d10 burst. Each shot drains 1 SEU, bursts drain 10 SEU but provide +20 to hit. Range is 5/15/30/60/150 because the smaller beams diffuse more rapidly. Defense: albedo.

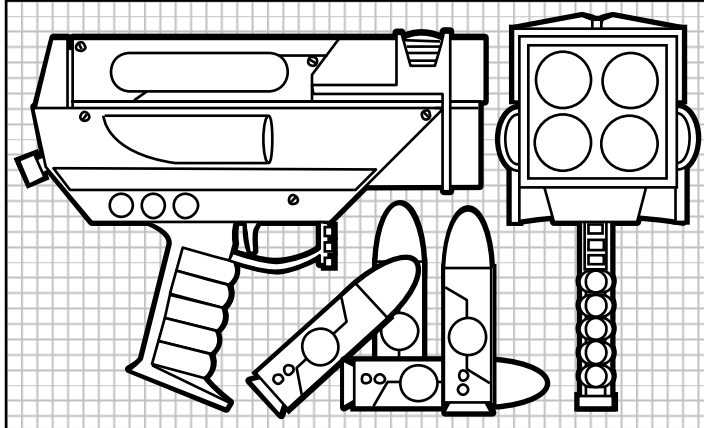

ELECTRO-MAGNETIC SIGNAL STUNNER

By Stephanie Logan

The EMS Stunner isn't a weapon designed to hurt a person. It won't even stun a normal person. It's designed by Star Law to stop vehicles and other simple machinery that relies on simple energy coils.

The weapon is a very heavy one-handed device, aimed forward and fired. It fires only one shell per turn. The range is somewhat short, but the shells are self-propelled (like a gyrojet bullet). The shell moves somewhat slowly, and is difficult to aim. But the shooter normally doesn't need amazing precision: he's firing at an enemy vehicle.

When the shell strikes the vehicle, it creates a powerful pulse of energy that interferes with the magnetic field generated by parattery-powered simple drive systems. Any normal vehicle or low-power robot (levels 1 or 2 robot, and any simple machine no bigger than a skimmer) will be affected when hit.

Once the shell strikes its target and releases its magnetic pulse, it is expended and useless, having burned itself out. EMS Stunner shells are purchased in loader cells of four. The weapon can be loaded using these loader cells in one turn (the empty cell being discharged and wasted). Shells are somewhat heavy – a loader cell with four shells costs 250Cr and weighs 1kg.

The vehicle may be disabled, but there are so many varying factors involved that a successful hit (using Projectile Weapons skill) causes no damage but instead a roll on the following table becomes necessary. Note that modern computers in the Frontier are sufficiently shielded and have enough built-in redundancy that their more complex circuits cannot be affected by this weapon):

EMS STUNNER DAMAGE TABLE

D10 Effect

| | |
|-----|--|
| 1-2 | No effect. |
| 3-4 | Vehicle's current speed is cut in half. |
| 5-6 | Vehicle's controls are jammed – won't turn. |
| 7-8 | Vehicle is disabled. |
| 9-0 | Vehicle is disabled and needs engine overhaul. |

Summary: The EMS Stunner costs 500Cr and weighs 2kg. ROF: 1 shell, Damage: special, Range: -/5/50/100/150, Defense: Inertia. Ammunition comes in 4-shell loader cells and cost 250Cr, weighing 1kg. This weapon requires a bounty hunter or star law license to purchase.

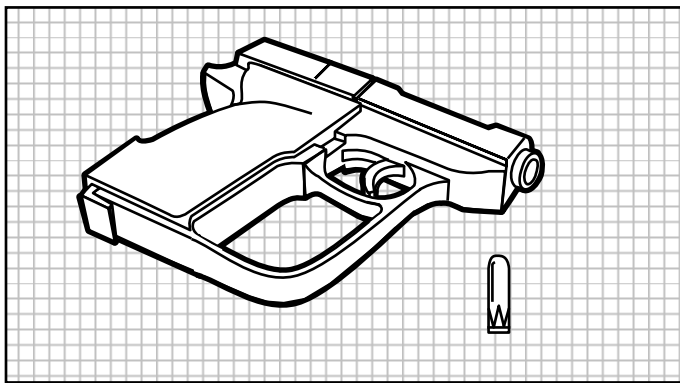

GEL AIRGUN

By Hunter Logan

The gel airgun (commonly called a "goo-gun") is a small pistol that fires large projectiles using compressed air cartridges. The projectile has a very short range, but is comprised of a gelatin core within a microplast encasing. The gelatin projectile shatters on impact, releasing the contents of the capsule on the target. It costs 250Cr and weighs 1kg.

The weapon can fire up to twice per turn. The airgun can hold ten projectiles inside of its spring-loaded advancement chamber. Each time the air cartridge launches a bullet, the next one is automatically advanced to the firing chamber. No combustion occurs, and the firing is nearly silent (except for a slight cough noise). The gel bullets must be reloaded one at a time (there is no quickload clip or magazine for the gel airgun). A skilled character has little trouble reloading. One bullet can be reloaded per turn, plus the character's level in Projectile Weapons. Thus, a character with 4 levels in Projectile Weapons skill can reload 5 gel bullets per turn. If the weapon is found on the body of a fallen foe, it will have 1d10 gel bullets remaining. Gel bullets come in three forms (others may exist), and cost accordingly:

GEL BULLET TYPE TABLE

| Bullet | Cost | Qty | Effect |
|-----------|------|-----|----------------------------|
| Acid | 20Cr | 10 | 3d10 |
| Practigel | 10Cr | 50 | Stains clothes, stings. |
| Dozegel | 20Cr | 10 | STA check or KO d10 turns. |
| Toxin | 30Cr | 10 | S5/T10 poison |

The compressed air cartridge that accelerates the gel bullet is disposable and depletive. It holds 1000psi (pounds per square inch) when it is new, and can launch a gel bullet 100 meters. Each time it fires, it loses 50psi (and subsequently 5 meters from the range it fires). For example, if the cartridge is drained down to 750psi, it can fire 75 meters. Because the maximum range is variable, the range categories are simplified for this weapon. Firing at up to half the current maximum range provides no penalty. Firing beyond that is at -40. The cartridge can be replaced at any time, which takes one turn. If found on the body of a fallen foe, it will have 2d10x50psi remaining. A new compressed air cartridge costs 10Cr (weighs negligibly) and can be purchased at hobby shops, as it's commonly used for other devices.

Summary: Gel Airgun. Cost: 250Cr, Weight: 1kg, ROF: 2/turn, Damage: varies by gel bullet type, Range: special, Defense: Inertia. Ammunition: varies by type, also must purchase and manage 1000psi air cartridges, each shot drains 50psi.

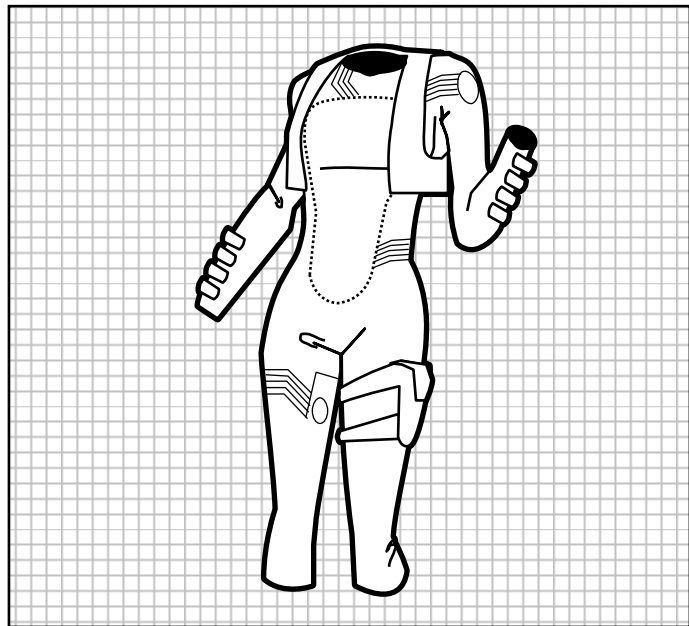

SHOCKSUIT

By Larry Moore

The shocksuit is a tight-fitting, light-gray, thick, cloth over-all that includes surface wiring and a plastirubber inner insulation lining. It comes in two varieties: defensive and offensive.

The defensive suit offers protection through a series of collectors, dissipaters, and insulation against electric shocks (stunsticks, electrostunners, shock gloves, electric swords, etc.) It is worn like any other defensive suit (and cannot be layered with others). If the character is forced to make a STA check from an electrical-based Stun attack (any attack that lists "A-S/Gauss" as its defense), that energy gets harmlessly shunted, protecting the wearer. It is as effective as an anti-shock implant, offering the exact same protections but at a fraction of the cost (300Cr instead of 2,000 for the implant).

The dissipaters are ablative, however, and the insulation wears down over time and use. Each time the suit protects its wearer, it takes one point of damage. When it has taken 10 points of damage, it no longer has sufficient protective safeguards to protect its wearer and it needs replaced. As it sustains this "damage" to its circuits and insulation, the light gray starts to blacken and its wiring becomes more obvious. A trained eye can look at a damaged Shocksuit and guess how many more times it will offer its protection.

Suits can be purchased for each of the core races.

The offensive suit offers identical protection, but includes a feedback circuit and a hip-mounted control compartment including a slot for a 20-seu powerclip. The control compartment allows the suit to be set to receive verbal commands or other activation methods, to release a corona of electrical energy, ionizing the air around the wearer. Any living being touching the character at that moment must make a STA check or fall unconscious (unless protected with A-S/Gauss defenses).

Each offensive use of the suit drains 4 SEU, meaning it will function five times before being depleted. The wearer of the suit is protected against the effect, and it doesn't damage the suit. An offensive shocksuit costs 750Cr.

Summary: Defensive shocksuit provides protection 10 times from shock effects and costs 300Cr. Offensive shocksuit is identical but can be activated (draining 4SEU from its 20SEU powerclip) to stun all those touching the wearer (STA check or A-S/Gauss protection prevents), costing 750Cr.

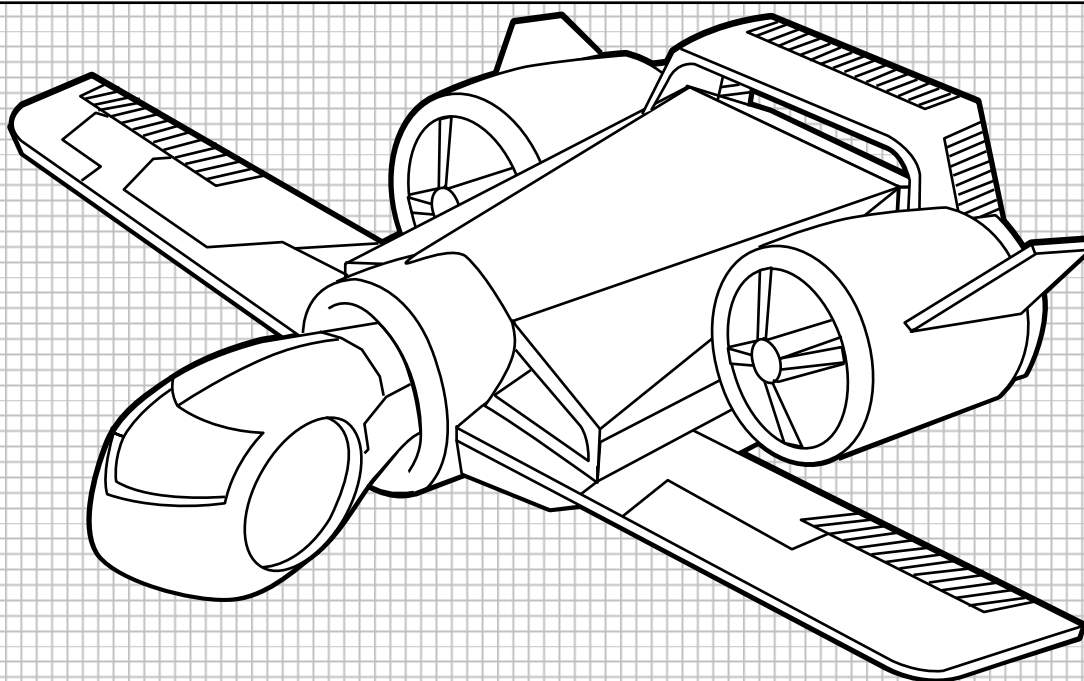

SKIPFLYER

By Auden Reiter

OVERVIEW

Skipflyer is a generic term for a transport vehicle that can operate both in atmosphere and space, without being able to exit or enter an atmosphere on its own. They are primarily used as cargo vehicles, transferring cargo from warehouse to ship or from ship to ship. Alternatively, they are used as work shuttles for maintenance crews.

FLIGHT

In atmosphere, a skipflyer uses one of several flight systems from vectored thrust nozzles, to high efficiency jet pods. Some skipflyers even have retractable or folding wings to help with lift or stability. While not the speediest or most maneuverable vehicle, the skipflyer has more than enough power to do what it does best: haul cargo at high altitude, neatly avoiding traffic or geography problems.

In space the flight systems reconfigure for burning some type of reaction mass, usually acting as both main propulsion and reaction control. Again, a skipflyer is a utility vehicle, lacking both grace and speed.

BODY

A skipflyer's passenger compartment can seat two to six, including a pilot, and is usually airtight. The average skipflyer can maintain a fresh atmosphere for 12 hours, three times that with emergency scrubbers. Some models feature retractable canopies, which are notorious for their air-seal failures.

The rest of the hull configuration varies a lot from manufacturer to manufacturer and more than one

capable mechanic has built skipflyers from scratch or cobbled one together from parts of other vehicles.

PERFORMANCE

As mentioned above and by every pilot that has ever flown one, a skipflyer is not pretty in flight. It is purely a utilitarian vehicle, slow, noisy, and ugly. However, they are renowned for their ruggedness and ability to run forever, even when held together by puncture sealant and farming wire.

Alpha Dawn Stats

Cost: 280,000 Cr
 Top/Cruise Speed: 700 kph/235 kph
 Passengers: 2 to 5
 Cargo Limit: 12,000 kg, 30 cubic meters

Knight Hawk Stats

Hull Points: 5
 ADF: 2
 MR: 2
 DCR: 15
 Weapons: None
 Defenses: None

PERKS

Rugged - Skipflyers are known for their ability to take punishment under normal conditions. Reduce non-combat related damage by 25%.

FLAWS

Sluggish - The skipflyer is made for hauling cargo, not flitting around system. 1/2 normal ADF and MR.

Author's Note:

Hope on High's Skipflyer:

The *Hope's* crew use an early Model 7 "Grekot" air/space light cargo transport manufactured by Yunch Aerospace. The Grekot houses a hearty Wansom powerplant that feeds four vectored thrust nozzles. The overpowered flight system gives the transport a little extra push for the heavy cargo or speed when not encumbered. Though Keel't constantly complains about the Grekot's sluggish controls and lack of style, she is the first behind the controls once *Hope on High* is on the ground.

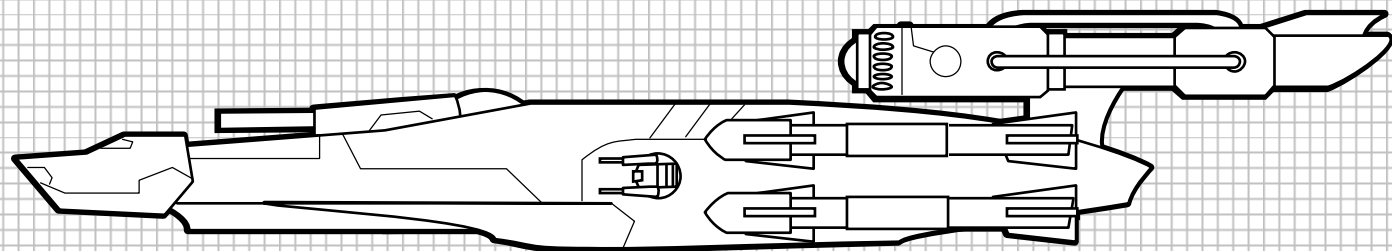

LIBERTY-CLASS PATROL GUNSHIP

By William Signs

OPERATIONAL HISTORY

In 72 f.y., two years into the Second Sathar War, the Mhnome Confederacy designed and built their first interstellar-capable combat vessels at their L5 spaceship construction facility.

The Mhnome built a size 4 spaceframe around a pair of laser cannon, a pair of laser batteries, four externally-mounted and launched torpedos and the newly-developed pion engine, with crew space being an afterthought.

The first five Liberty-class gunships—Osprey II, Eleanor Moraes II, Flying Cloud II, Liberty and Shooting Star—were immediately placed in service with Task Force Liberty (formerly Strike Force NOVA), soon proving their worth as rapid-response, first-strike vessels capable of long-range hit and run assaults against Sathar fleets throughout the Frontier, the gunships of Strike Group Liberty Foxtrot being instrumental in Task Force Liberty's ambush and destruction of Sathar Fleet #3 during the Battle of Moonworld, the UPF commissioning the Mhnome to begin producing gunships for service with the Joint Reaction Forces.

The Liberty-class gunship was to play a pivotal role in the Battle of the Blockade in 73 f.y., JRF #1's VPG-109 accounting for the majority of enemy vehicles destroyed during that battle.

SPECIFICATIONS

A Liberty-class gunship houses a crew of fourteen beings under extremely Spartan and cramped conditions, the utilitarian philosophy of the Mhnome applying even to the layout of the bridge controls; the captain occupies the pilot's station and operates the lasers, with all other stations essential to the operation of the ship—including engineering—laid out in a circle around the pilot and astrogation stations, the entire bridge section serving as an emergency escape pod.

The second deck houses four single cabins and five double-occupancy cabins, along with a sickbay (often compared unfavorably to a broom closet by most gunship flight surgeons) all surrounding a common area serving as rec room and galley, the latter consisting of a rehydrator/microwave unit and a larder full of freeze-dried meals.

The third deck is the ship's docking area, and the last area directly accessible by the crew; it holds the main airlock, as well as the docking cradles for the ship's two

launches—a four-person launch serving as the captain's gig, and a ten-person launch serving as the troop carrier for the six-being marine combat team carried aboard—and two workpods.

The final deck, the engineering deck, is sealed off from the rest of the ship and serviced entirely by robots. In addition to access for the pion engine, the deck also holds tankage for the ship's liquid hydrogen supply, as well as a processing lab to harvest hydrogen from water and methane.

The pion engine itself is on a strut extending from the engineering deck. It can be accessed by the crew via an external inspection hatch on the strut, the ladderwell leading down into the engineering deck as well as up into the engine itself.

Capable of seven gravities' of acceleration, the gunship's crew wear special anti-g flight suits with gel padding and exoskeletons, and all bridge stations have gel-filled acceleration couches with gel-padded restraining straps, all designed to compensate for the effect of high acceleration.

GAME INFORMATION

| | | |
|--------------|--------------|--|
| HS 4 | HP 30 | Powerplant: Single Pion B engine |
| ADF 7 | MR 6 | DCR 40 Crew 14 |

Armament:

Laser Cannon (x2), Laser Battery (x2), Torpedo (x4)

Defenses:

Reflective Hull, Masking Screen (x4), Interceptor Missiles (x4)

Communication/Detection Equipment:

Subspace Radio, VideoCom, Radar, Energy Sensor, Intercom. Misc Equipment: Reinforced Hull, Cargo Arm

Cargo/Crew:

Cargo Capacity: 0.5
Crew Accommodations: 4 single cabins, 5 double cabins
Passenger Accommodations: n/a

Ship's Vehicles:

lifeboat, 1 small launch, 1 large launch, 2 workpods

Cost:

1,566,734Cr at a Class I Starship Construction Center.

TURNOATS OF THE FRONTIER

By Di Mo

TURNOATS OF THE FRONTIER

dimolaoshi@yahoo.com

The constant and repeated discovery of new bands of traitors is one of the great mysteries of the Frontier. Every resident of the Frontier knows the Sathar to be an implacable enemy, bent on eradicating the four major races from the UPF and completely uninterested in any sort of compromise. Most Frontier residents have at some point in their lives been directly physically threatened by the Sathar: even most noncombatants on the Frontier worlds can recall anxiously watching live holoivid coverage as Sathar fleets advanced toward their homeworld in the Second Sathar War. Given Frontier feelings about "the worms", the number and size of spy rings in the Frontier is truly mind-boggling.

Yes, the Sathar are capable of hypnosis. Clearly this is a major factor in the success of Sathar infiltration attempts. But it doesn't fully explain the numerous complex networks of plotters that have been discovered around the Frontier. We know, for instance, that the Sathar can conduct hypnosis only in a non-combat situation – and we know that all beings in the UPF are under orders to flee or fight at the first sight of one of the worms. While some traitors may have hypnotized as the result of being captured in an attack, it is clear (from subspace radio reports) that many traitors have simply allowed themselves to talk to the Sathar.

The motivations behind talking to the Sathar are mysterious enough. But even when beings talk, hypnosis alone does not explain the long double lives of perfidy carried out by many traitors. The Sathar can program their hypnosis victims with simple and direct commands, but long-term spying

requires a number of conscious actions by a sentient being. When you're carrying secret documents and Pan Galactic Corp. security is about to search you, your Sathar programming isn't going to help you! You have to think for yourself.

To understand the motives and methods of spies on the Frontier, it's helpful to keep in mind an acronym developed by Human intelligence authorities before the Sathar appeared on the scene. The acronym is MICE, and it stands for Money, Ideology, Comprise and Ego – the four major motivations of traitors. All four of these motivations work together to reinforce each other, with compromise as the keystone.

MONEY

They say that every being has its price, and unfortunately, the Sathar war has proven that adage to be perfectly true. As any Frontier adventurer knows, the Credit is a powerful motivator, able to force beings to risk life and limb.

For "direct" traitors – those who have had direct contact with the Sathar and fully understand what they are doing – money may not be the primary reason for betraying the UPF. But once a traitor's career has begun, monetary reimbursement from the Sathar quickly becomes a major motivator. The Sathar and their handlers typically pay their agents just enough to buy things that are beyond the agents' means, or take agents to vacation spots they could not afford to visit themselves – always with the promise of a much greater payoff if the agent continues to serve. Many agents have been caught because they boasted about or showed off their too-expensive lifestyles, encouraging friends or colleagues to tip off Star Law. PCs should also be suspicious of someone who suddenly and inexplicably turns up with a shiny new hover car, and they may face suspicion if they return from an adventure flush with credits.



Money is of course the main motivator for "indirect" traitors -- those who work for Sathar front organizations or in the employ of direct Sathar agents. Even the mafiosi of the Frontier are repulsed by the idea of turning traitor, and in fact some traitors have been turned in by underworld figures. However, long before the Sathar arrived on the scene, the Frontier was filled with profit-hungry individuals who were willing to work in shady industries without asking a whole lot of questions. Many space pirates are working indirectly for the Sathar. They do not know this, and they do not want to know!

There are also rumors that one of the major Frontier corporations has made financial deals with the Sathar. For legal and other reasons, that corporation will go unnamed in this piece. For more information, refer to the work of the late journalist Rax Brayad, the subspace feeds of the anonymous author known as "Gorluu the Dralasite," or the works that appeared the Fromeltar Herald just before its offices were destroyed in that freakish and well-publicized cargo ship crash.

Interestingly, it is not known whether there is a "money" concept within Sathar society. Based on what we know now, it seems unlikely that the UPF will ever be able to conduct espionage among the Sathar using similar techniques.

IDEOLOGY

It would be a gross injustice to imply that all, most, or even a large minority of dissenters are traitors. But the discovery, five years ago, of an elaborate cel of Sathar agents at the University of Fromeltar offered a fearful public a bit of hard evidence to support its suspicions about the Frontier Peace Organization. The Sathar had almost completely infiltrated the university's population of FPO supporters, and almost everyone with a traceable tie to that FPO branch was found to be working, directly or indirectly, for the worms.

Across the Frontier, other members of the FPO reacted to the news with shock and anger. Most other chapters of the group issued angry denunciations of the Fromeltar band, and took pains to underscore their overall allegiance to the United Races, while maintaining their skepticism about the UPF. Many individual members severed their ties with the organization.

This author is willing to take FPO members at their word, and recognizes that dissent is far from disloyalty. But the sad fact is that, in a savage war like the one being waged on the Frontier, dissident groups do make appealing targets for enemy intelligence operations. Because they don't buy the "official line" on the Sathar War, FPO supporters are

more likely to listen to an appeal from an agent, or from an actual Sathar -- as opposed to shooting first. Because they distrust Star Law, dissenters are much less likely to report an appeal of this sort when they hear it. Because they are shunned and isolated on many worlds, dissenters have fewer ties to the larger community -- ties that might make them think twice about cooperating with the Sathar.

Unfortunately, that isolation has grown since the discovery of the cel in the Fromeltar system. Governments around the Frontier have used the cel as an excuse to crack down on the group. On more repressive worlds, FPO members, even those who denounced the Sathar agents or left the organization, have been jailed and held without legal representation. On more "democratic" worlds, FPO groups report increased, and increasingly intrusive, eavesdropping and surveillance by the authorities.

The crackdown has actually led to a resurgence of the FPO on a number of worlds. By using the war and espionage as an excuse to crack down on this and other dissenting groups, Frontier governments gave credibility to the FPO's central argument -- that the war is an illusion created by the UPF to support massive government expenditures and repression. Overblown kill counts from the front (where only a handful of Sathar bodies have actually been recovered) and stupid security policies (like the Clarion government's baffling insistence that all citizens carry an allweather blanket in case of a Sathar attack) only add to the dissent. Star Law has for the most part stayed aloof of planetary governments' overzealous crackdowns, but the group's reputation has still suffered, as the law enforcement agency is often (incorrectly) seen as the puppet master behind all Frontier police agencies.

The FPO is clearly fashionable on college campuses now, a situation that would have been unthinkable at the beginning of the Second Sathar War. Counter intuitively, the anti-Satharian League is actually struggling to keep up, particularly on worlds where the group is most tolerated.

It is not clear where this chain of events will lead. Clearly, with small cracks now appearing within the once rock-solid credibility of the UPF and Star Law, the Sathar may see an exponential increase in the number of potential ideologically-based traitors. We may see an increase in spy recruiting as a result (or more accurately, such a thing may happen even if we don't see it!) However, the sentient mind is a mysterious thing, and it is quite possible that many newly-minted "dissidents," confronted with an actual opportunity to spy, would revert to their old way of thinking and run directly to Star Law for assistance. Indeed, the UPF's next powerful double agent within the Sathar spy network could some

from this crowd. The current situation holds a great deal of potential for spy networks on both sides.

COMPROMISE

Blackmail is the linchpin that holds any traitor's career together. If the Sathar or a Sathar handler know something scandalous about a being, something that would cause that being to be shamed or ostracized, that person can be convinced to work for the worms in exchange for the promise to keep the secret hidden.

This sort of compliance may start out small. For instance, an accountant may provide a handler with a pair of fake IDs if the handler will not reveal that the accountant has been embezzling from his company. However, it will not end there. The handler now knows a bigger secret: he knows that the accountant is now an accomplice of the Sathar, a much more serious offense. Soon, the handler will ask the accountant to leave a door unlocked at a crucial time, or copy crucial documents, or funnel embezzled money to an account that funds the spy network. Each act of treason makes the traitor more compromised, and plants him more firmly in the pocket of the spy network.

Until the Sathar came along, most traitors were compromised through their own shameful actions. Sadly, Sathar hypnosis has compromised many beings who were previously exemplary fighters against the worms. There are a few brave individuals who, upon realizing that they have been hypnotized, have come forward and reported themselves to authorities – usually at the cost of death by vacuum. But most are not that brave. Often an adventurer will perform a single command under Sathar hypnosis, get away with the act, and try to bury the memory for years – until a handler shows up, promising to reveal the adventurer's treason if he or she does not become a full-fledged agent.

EGO

Suppose you are working for the Clarion Royal Marines for 40 credits per day – a situation to which many adventurers can relate. Suppose you find contraband on an incoming ship, and engage in a fierce battle with the smugglers. And suppose in that fierce battle, your own ship is heavily damaged, and the smugglers' ship utterly obliterated, contraband and all. When you return to Clarion station, you face a Review Board, which will decide whether to commend you for valor – or clap you in the brig for malfeasance.

Suppose that, while awaiting trial, you are approached by a "headhunter" for a major corporation. "Why are you putting your life on the line for Clarion?" he asks. "Forty credits a day for these people who do not value your talents – and



you're not even from Clarion." The headhunter offers to triple your pay and give you an impressive title if you will come to work for his outfit. Will you take it?

Of course, leaving the Marines for the private sector may not be treason, but this scenario is similar to what the traitor often faces. Traitors are often low-level officials who feel unappreciated by their superiors and undervalued by the culture at large. Often, these beings live in a fantasy world in which they are adventuring heroes – even though they lack the courage or skill to make those fantasies real. By becoming a spy, a low-level functionary can take on a role straight out of an adventure holovid, without showing a great deal of physical bravery. Handlers are very good at spotting these troubled individuals, and flattery will get them everywhere.

While adventurers are usually not susceptible to ego-based appeals, they should keep an eye out for clerks and other low-level officials who seem unreasonably cocky, too intensely interested in the adventuring activities of PCs, or too knowledgeable about spies in general. These people are often targets for spy handlers.

FOR GAME MASTERS

While most Star Frontiers campaigns boil down to little more than "find the traitor, blast the traitor," the nuances of "traitor culture" allow for some interesting gaming possibilities. Here are a few examples:

- **Worms, Inc.** – The PCs find themselves working for an organization which turns out to have some shady connections including possible connection to the Sathar. The PCs have a moral duty to investigate these ties, while working on the jobs that are paying their bills. If they do expose

evidence of Sathar involvement, they will have to deal with the short-term consequences (their former employers trying to kill them) as well as long-term ramifications (the social stigma associated with people who have worked for a Sathar front organization.)

- **A Second Chance** – with a Price. If an entire group of PCs are gunned down by the Sathar in the course of normal play, the referee can use a treason-related theme to bring them back – at a price. An example: the PCs engage a band of Sathar in a gun battle on Volturnus, and each character loses all his/her stamina points in the battle. After the last character is "killed," the characters are awakened, in exactly the place where they "died," by rescuers from Star Law. The Sathar are gone, each character has 15 stamina points, and there is no evidence anyone has been in a freeze field. Also, several hours have passed since the attack, and the time is cannot be accounted for. Shortly after the PCs are rescued from this predicament, some act of treason jeopardizes the Star Law ship which is carrying the characters home. Obviously, the characters become objects of suspicion, as the crew put two and two together, assuming the PCs have been captured and programmed by the Sathar. The PCs (who do not know whether or not they are indeed traitors) must find evidence to exonerate themselves. The PCs may find that they were aided by heretofore unknown aliens on Volturnus – or they may find that they are indeed victims of Sathar hypnosis!
- **The Unthinkable.** One or more player characters are captured by the Sathar, and programmed with a treasonous command which the character carries out. This "treason" is involuntary and known only to the player whose character has been hypnotized. The player must then decide whether to confess and help investigators (and accept the harsh social and judicial consequences) or keep the treason secret while seeking ways to avenge himself on the Sathar. Rest assured, the Sathar or their agents will be back to seek more support from the "compromised" character. Once other player characters discover the PC's "treason," they will have to decide how to respond. Should they help their fellow PC clear his name, or execute him on sight. If they do remain loyal to their friend, the PCs will also find themselves "compromised" and may be approached by Sathar agents as well.



A Sathar Fighter, by Gavin Dady

THE TETRACHS

By C.J.
Williams

THE TETRACHS

In the distant past an ancient race once ruled the galaxy. They were at once great conquerors and by all counts benevolent rulers. Were they truly benevolent or were the records colored by fear? Little is known about this race, but one thing is known for sure: they are called the Tetrachs.

You may be familiar with some of the following statements found in Frontier literature:

"The Tetrach Societies are assumed to be a once great galactic authority made up of a collection of races also referred to as the Tetrach Elders . . . Some suspect that the races [of the Frontier] were slave races of the Tetrach Elders, left behind . . ."
—Nor's Guide to Allied Space*

". . . an ancient temple left behind by a race who have a connection with the Tetrachs."
—Temple Raiders**

"It has been speculated that an ancient unknown race of aliens (possibly the group known to xenoarchaeologists as the Tetrachs) transplanted a small group of S'sessu to their present homeworld at that time."
—Coming of the S'sessu***

The Tetrachs have taken on a mystical and even god-like aura in Frontier history, but most never even hear the name. It is talked around in scientific and historical societies, obscure religions, and secret organizations, but little ever reaches public circles, and usually only in exhaustive encyclopedias. One reference can be found in a textbook at the Zebulon Institute for Archaeology. In there, a timeline is given, claiming:

*"10,500PF (Pre-Frontier) Last remnants of the mysterious Tetrach Societies die out."*****

The Tetrachs appear to have been the most technologically advanced society ever in the Frontier or its outlying areas. Their territory is suggested in ancient accounts to stretch beyond any known territories. References and varying depictions of the Tetrachs are found up until around 10,000p.f., at

Editor's Note: C.J. Williams surprised me by coming up with this article. I thought I had never heard of the Tetrachs until he cited these references, then I remembered reading it in the past. Why had I not considered the relevance a pre-Frontier high technology race would have on exploration-type campaigns, or even military ones. This is one element of Star Frontiers hinted at throughout texts yet never officially developed: a gold mine for the creative referee to build amazing lost civilizations and technologies that seem like magic.

which point they just drop off the historical record.

A later race known as the J'vaarians are believed to be descendants of the Tetrachs, but nothing in the historical records ever show a direct connection.

Depictions on ancient temple walls and artifacts show ancient races interacting with what are believed to be the Tetrachs. However, though many ancient artifacts, technological and otherwise, have been found, none have been definitively linked to the Tetrachs.

Some races claim descendance, while others claim to have been created or enslaved by the Tetrachs at one time, but no archaeological evidence can be found to support such claims, except elusive references in their culture to their beginnings and ancient trials. These claims lead many to believe that the tetrachs were masters of creating and manipulating life, forming new races and species.

One theory suggests that many of the races in the Frontier made up the Tetrachs, but an apocalypse brought about a dark age that erased their histories. It has been suggested that the Klikk, who some speculate to be an early Vrusk race, were one such division of the Tetrachs or perhaps were possibly responsible for their demise.

After approximately 10,000 years ago, the Tetrachs would never again be seen in the Frontier. Despite all the efforts of archaeologists and historians, little do they know that the mystery of the Tetrachs will forever be hidden in time.

* Ron "Seawolf", http://www.seawolfsden.net/sf/ronsf.php?id=timeline_asf

** Star Frontiersman #4, pg 36, by C. J. Williams, 2007.

*** Dragon Magazine, April 1985, by David "Zeb" Cook.

****Zebulon's Guide to Frontier Space, p. 52, 1985, TSR, Inc.

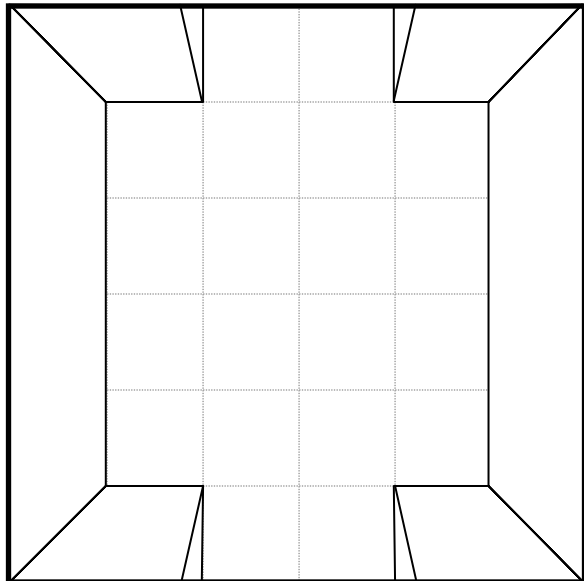
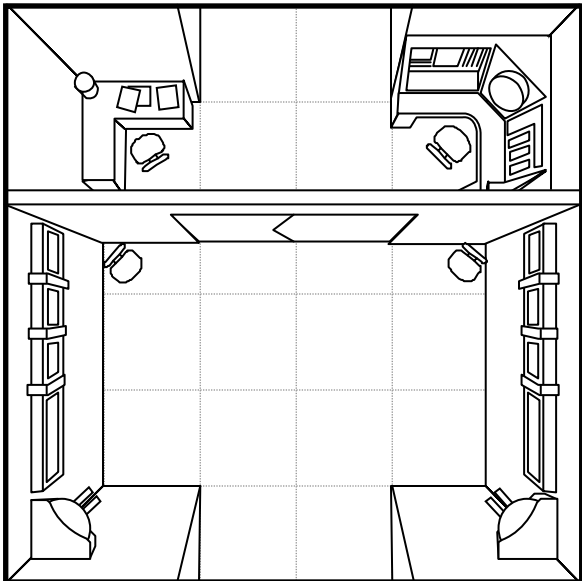
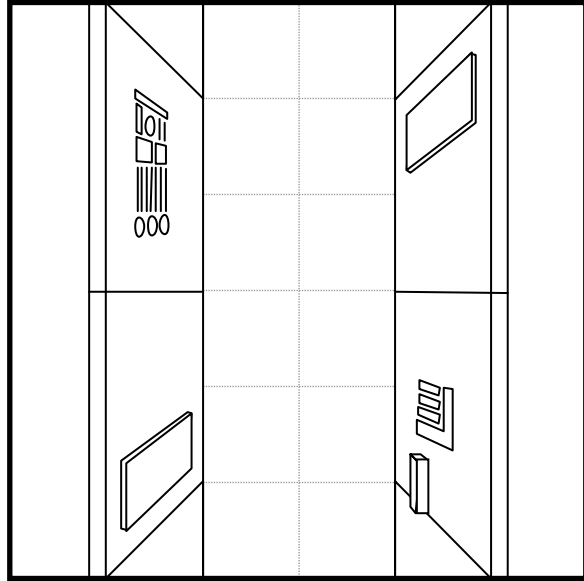
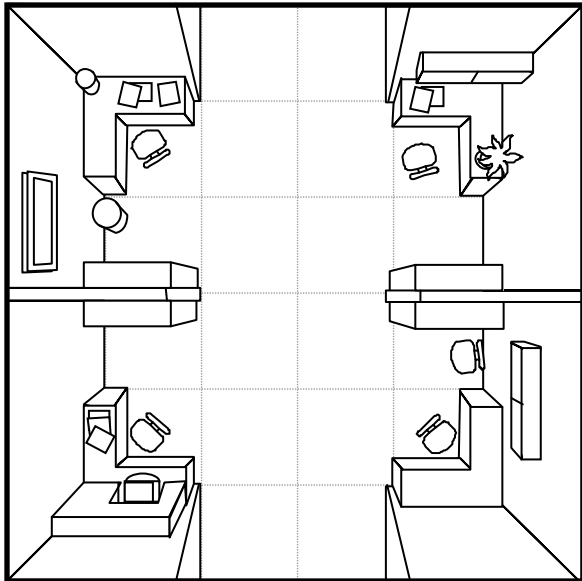
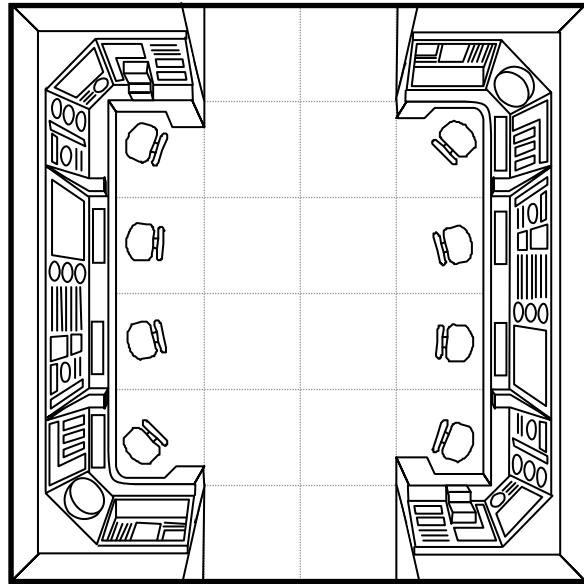
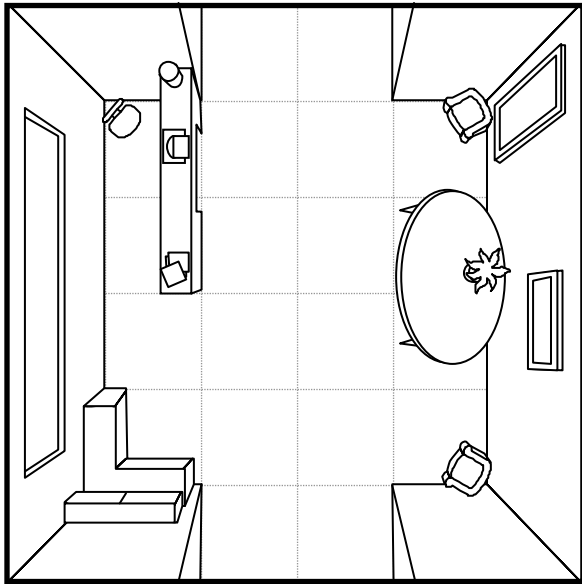

NOVEMBER 2007

Interior Map Tiles – Straights (including blank for creating your own).
Next month look for Interior Corners and Interior Intersections! --Bill Logan

MELEE TECH

By Bill
Logan

MELEE WEAPONS

Face it, the Frontier is a dangerous place. On many civilized planets, though, carrying around blasters and gyrojet rifles will get you into legal troubles. On some worlds, use of a melee weapon is vital for survival. Elsewhere, it may be a mark of personal honor or prowess to wield a personal weapon.

The Star Frontiers game has rules for several base types of melee weapons. They are described in detail in the manual and need not be repeated here. The table below lists a slightly more comprehensive (though by no means exhaustive) list of weapons found in use throughout the Frontier.

WEAPON QUALITY

Not all weapons are created equal. If you're low on Credits and need a melee weapon, you generally have two choices: buy cheap or go without. It's also possible for a character that has the Credits to pay extra money for a higher quality version of any base melee weapon.

CHEAP QUALITY

A cheap weapon costs only $\frac{3}{4}$ the cost of the base weapon, but the damage will be less (-1 per die of damage in the base weapon) due to poor weight distribution, inferior material, or damaged goods. For example: a cheap axe would cost 11Cr (that is, $\frac{3}{4}$ of the base price of 15Cr) but would do 2d10-2 damage (plus the character's Punching Score, of course).

HIGH QUALITY

High quality is characterized by superior technology in the tooling, the craftsmanship of the handle and grip, the improved balance and distribution of weight, and the more durable and effective materials used for the business-end of the weapon. The weapon will cost twice as much as the base weapon, and will add an additional +1 point of damage per d10 in the damage code of the base weapon. For example: a high quality spear would cost 40Cr (twice the cost of the base weapon) and cause 2d10+2 damage (plus the Punching Score of the character) on a successful hit.

MELEE WEAPONS CONSTRUCTION TABLE

| Melee Weapons | MW | Damage | Defense | Hands | SEU | Thrown Range | Wgt | Cost |
|-----------------------|-----|------------|-----------|-------|--------|---------------|-----|-------|
| Base Weapons: | | | | | | | | |
| Axe | +5 | 2d10+PS | Inertia | 1 | -- | 5/10/15/20/25 | 1 | 15 |
| Brass Knuckles | +0 | 1d10+PS | Inertia | 1 | -- | -- | 1 | 10 |
| Knife | +5 | 1d10+PS | Inertia | 1 | -- | 5/10/15/20/25 | -- | 10 |
| Mace / Club | +5 | 2d10+PS | Inertia | 1 | -- | -- | 1 | 20 |
| Nightstick | +5 | 2d10+PS | Inertia | 1 | -- | -- | 1 | 20 |
| Polearm | -10 | 4d10+PS | Inertia | 2 | -- | -- | 4 | 40 |
| Spear | +15 | 2d10+PS | Inertia | 2 | -- | 5/10/20/30/40 | 1 | 20 |
| Staff | +5 | 2d10+PS | Inertia | 2 | -- | -- | 2 | 20 |
| Sword, great | +0 | 4d10+PS | Inertia | 2 | -- | -- | 4 | 50 |
| Sword, normal | +10 | 3d10+PS | Inertia | 1 | -- | -- | 2 | 30 |
| Sword, short | +5 | 2d10+PS | Inertia | 1 | -- | -- | 1 | 20 |
| Whip | -5 | 1d10+PS | Inertia | 1 | -- | -- | 1 | 20 |
| Quality: | | | | | | | | |
| High Quality | +0 | +1 per die | Inertia | -- | -- | -- | +0 | x2 |
| Cheap Quality | +0 | -1 per die | Inertia | -- | -- | -- | +0 | x0.75 |
| Modifiers: | | | | | | | | |
| Electric | +0 | +1d10/stun | Gauss/A-S | -- | 2/hit | -- | +0 | x5 |
| Sonic | +5 | +2d10 | Sonic | -- | W/hit* | -- | 1 | x5xW* |
| Vibro (blade) | +0 | +1d10 | Inertia | -- | 1/hit | -- | +0 | x2 |

* "W" refers to the Weight (in kg) of the base weapon to which the "Sonic" modifier is applied.

WEAPON MODIFIERS

The Alpha Dawn book lists several weapons that have had their usefulness improved by high technology: the electrosword, vibroknife, sonic sword, etc. Terms like "electro" and "sonic" are weapon modifiers, and can actually be applied to many different types of weapons (referred to as its "base weapon") using the guidelines below.

ELECTRIC WEAPONS

Any standard melee weapon can be purchased as "Electric" - not just the sword. The handle of an electric weapon has a slot in it for a standard 20-SEU power clip, as well as a power port for connecting a cable to a power backpack or backpack. Any hit from an electric weapon drains 2 SEU from its power source.

The electric charge delivered by the weapon can cause one of two effects, depending on how the weapon is used. A simple selector switch in the handle can be placed in "damage" or "stun" positions. When in "damage" mode, the weapon causes damage equal to the base weapon's damage rating +1d10 upon a successful hit. When set to "stun," the weapon must strike in a non-wounding manner (using the flat of the blade, etc.) and will cause no damage, but the victim struck must make a current STA check or fall unconscious for d100 turns.

Both "electric" effects are blocked by a Gauss Screen or Anti-Shock implant (if protected by such defense, the weapon will still cause "Inertia" damage equal to the base weapon's damage rating).

Electric weapons weigh as much as their mundane counterparts, but cost five times more.

An electric version of a weapon is sometimes called a "stun," "shock," or "electric" weapon. Common examples found in the Frontier include Electric Swords and Stunsticks. Shock Gloves can be created by applying the electric effect to brass knuckles.

SONIC WEAPONS

Sonic blades have their blades removed, leaving a handle only. If the base weapon has no blade, then the end that is used to cause damage has been removed (like a mace head, for example). The handle is made of a light-weight material normally, incapable of causing much damage on its own. A standard powerclip can be inserted into the handle, or a power cable can attach the handle to a power backpack or backpack. When a button is pressed on the weapon's handle, a beam of focused sonic force is released, creating an invisible blade of very destructive energy (along with an identifiable high-pitched noise).

The weapon causes the base weapon's damage +2d10. Thus, a sonic sword is based on a normal sword, so the damage caused is 5d10 (swords normally do 3d10).

The SEU drain per successful hit is based on the weight of the base weapon: a sword normally weighs 2kg so a sonic sword drains 2 SEU from its power source per successful hit. The minimum drain is 1 SEU per hit, even for a knife.

Any base weapon made "sonic" causes no "Inertia" damage; all of its damage is "Sonic" in nature. This means any sonic weapon is useless against a person protected by a sonic screen.

The cost of a sonic weapon is equal to 5 times the weight of the base weapon times the cost of the base weapon (treat the weight of a knife as 1kg for this calculation). For example: a normal sword costs 30 Cr and weighs 2kg. A sonic sword would then cost $5 \times 30 \times 2 = 300\text{Cr}$. All sonic weapons weigh only 1kg and can never be thrown, regardless of the type of weapon they're based on.

Common types of sonic weapons employed throughout the Frontier include the Sonic Knife and Sonic Sword.

VIBRO BLADES

Any standard bladed melee weapon can be purchased as a "Vibro" weapon, not just the knife. The blade of the weapon will be serrated and will vibrate at a high frequency, causing its edge to move rapidly in a cutting motion like a higher-tech version of a modern carving knife. A slot in the handle houses a standard SEU powerclip, and a power cable can be used to connect it to a power backpack or backpack. Each hit from a vibro blade drains 1 SEU from its power source.

Damage from a vibro weapon is +1d10, but the cost of the weapon is only twice that of the base weapon (weight is unaffected). The interesting advantage of a vibro blade over an electric blade is that the added effect, although powered, is mechanical in nature. This means that a gauss screen or anti-shock implant is useless. The damage from the effected weapon is still considered "Inertia" damage when applied against defenses.

The only common vibro weapon found in the Frontier is the vibroknife, though some guards like to employ a vibropolearm because of the added intimidation factor.

Author's Note: Of course, it's up to the Referee to be the final arbiter on all new rules. Check to be sure your Referee will allow you to walk around with Sonic Whips and Vibro Polearms.

JOIN THE REVIVAL!

WWW.STARFRONTIERS.US

WHAT WAS SOUGHT

There are a lot of talented people on the net. Some of them play role-playing games. Heck, some even play Star Frontiers. But this pool of talent goes untapped.

I'm a fairly decent paper & pencil artist (not great at all), a capable writer, and have a decent eye for layout design. I have a logical mind and can therefore analyze rules and find holes. I can organize well. These are the things I think I could bring to the table of a collaborative experience. What are your talents?

Some people have very creative storytelling prowess. Some people can illustrate, paint, or ink like a professional. Some people can write software to accomplish nearly anything. Some people think strategically, tactically, and have a mind for all things logical. Some people just enjoy playing games. All of these talents (plus a ton more I'm not thinking of off-the-cuff) if brought together could create something amazing.

I really wanted to find a way for all of these creative people to work together to build something they could all be proud of.

WHAT WAS FOUND

So I searched the web to find collaborative sites. I found gallery sites where people post their art and people give constructive criticism... I found community sites where people made profiles and got to know one another even if through the facade of the internet... I found wikis where people worked together on stories and tales and manuals for all things... I found open-source software projects where people worked together to create incredible software, complete with a system of support issues and dialogue... I found forums where communities discussed things through topical categories. I found a lot of things, but nowhere that gave me what I was craving.

Some sites came very close. RPG.NET has forums, wikis, articles, messaging, and a lot more. There was a great toolkit called the RPG Toolkit Wiki (put together by Andrew Modro) - it provided many of these features. Even MySpace has a nice system of community gatherings, messaging, forums, and even chat. But nothing delivered the type of site I hoped to find for collaborative development.

WHAT WAS BUILT

Not to be defeated, I made one. With the help of a handful of very bright site testers, I've spent the last three months working very hard (my family says too hard) learning, building, testing, fixing, expanding, and finally delivering a site devoted to collaborative community development and discussion of RPG material. I have decided to focus on a specific game system: Star Frontiers.

Why that game? People who have communicated with me in the past know all about my love for the old sci-fi classic. Many of you have read issues of the Star Frontiersman (a collection of submissions from very inventive and creative individuals who have a similar love for the game). Others have downloaded and enjoyed the re-organized and made-over (but not altered rules-wise) editions (I call digitally-remastered versions) of the original Star Frontiers game books. The game is long out of print, and has been made available free on the net through the officially-licensed StarFrontiers.com and StarFrontiers.org websites, both of which I truly enjoy. It's a great old game long forgotten by some but easily updated to the modern expectations of role-playing games.

The site that has resulted from these three months (with the long hours of effort put forth by the site's testers) is ready today. This article serves to describe it in some detail. I hope it helps you find it, navigate around on it, and join in the collaboration and fun!

INTRODUCTION

First off, I want to say that this site is not just a distribution place for those two pet projects of mine. The StarFrontiersman webzine and the Digitally Remastered rulebook conversions are but two of the many types of collaborative projects possible on this site. Some projects have already been begun by the site's testers - and I hope dozens more will spring up as time progresses. I hope you start one, and look forward to contributing to it.

FIRST IMPRESSIONS

When you first go to www.starfrontiers.us, you'll be faced with the front welcome screen. From here, feel free to browse around the site and get a feel for things under the guise of anonymity. The top of the page is a strip of navigation tabs - explained further below. The "Newest Topics" block only shows general site content, not content specific to any projects. The "Newest Members" block gives you an idea of who signed up recently, allowing site members to check out their profiles and welcome them. Lower on the screen (not shown in the image) shows the five most recently added projects. Click around and explore. You can't add any content to the site while anonymous, but you can read just about anything. When you're ready, click on "Log in or Register" in the navigation sidebar and sign up - it's quick and free. The rest of this description will assume you've done that.

Note: the site is best viewed with Mozilla Firefox, but works just fine in Internet Explorer version 7 and above. I have been told there are some display inconsistencies with Internet Explorer version 6 - so please update your browsers for the best experience!



SITE CONTENT

Conceptually, there are three basic types of site content. User Content, General Content, and Project Content. Each of these is described in more detail below.

USER CONTENT

User content is that information specific to users, not specific to a project or general to the site.

PROFILE

First there is the user profile. When you first create an account, you'll be taken to your user profile. At first, it's quite basic. Click "Edit" in the tabs and you'll be taken to your profile editor, where you can set user preferences about your account, create content for your profile, even select your avatar (or upload one of your own). There are also some special tokenized tags allowing you to make more attractive profiles (a more advanced topic best suited to its own). Here's part of my profile:

CLEANCUTROGUE'S PROFILE

BASIC INFORMATION

I am a software engineer by day and an artist by night... something for both halves of my gemini brain to focus on. I start a million projects and even finish a few... but I'm always busy occupying myself.

I'm married to a wonderful woman and have three great kids. We all roleplay to some extent or another.

Don't smoke... drink occasionally... and whatever I'm doing I'm having fun.

If I could choose a sound track for my life it would be full of the lamenting sounds of Ewanescence and the carefully controlled angst of Linkin Park... with a little Rob Zombie thrown in to relieve my stress!

A SYNOPSIS OF MY BRAIN...

I dance with my sanity
On top of a wall

I dip and I sway...
which way should I fall?

One side is ordered
With clear night and day

The other cast over
In chaotic disarray

As I step and I turn
In my mind's dancing hall...

I realize the truth:
- It's more fun on the wall!



Buddy Me

Message Me

Email Me

Sign Guestbook

MY BUDDIES

Corvus



Corjay

wDot

SmootRK

GUESTBOOK

September 11, 2007 - 6:36pm
Hey, Bill. Your avatar is starting to fade in the brilliance of the site. You should update to the Zeb avatar I sent you. It's not as faded.



Comment by CleanCutRogue
You sent me a 20 avatar? I can't find it anywhere... I'll keep looking!
- DELETE ENTRY | EDIT COMMENT

August 19, 2007 - 1:45am
I've been manipulated! I feel so violated. :P



PRIVATE MESSAGES

The site includes a robust private messaging system, allowing site members to communicate. It's a messaging system quite like other sites and so doesn't need a lot of explanation. There is a limit of 100 messages you may have in your inbox and your sent-items box combined, so try to keep it empty to prevent missing an important message.

GUESTBOOK

Users have public guestbooks where you can leave them comments. Like someone's artwork? Let him know. Like someone's profile or avatar? Let him know. Guestbooks are much like Private Messages, but everyone can read them.

QUICKLINKS

If you like to keep tabs on certain projects, you can add that project to your quicklinks directory. When you first sign up for the site you'll automatically have the StarFrontiersman and Digitally Remastered projects added to your quicklinks list. You can remove them or add more. Items in your quicklinks are just easy for you to get to in order to keep up with what's going on.

BUDDY LIST

If you want to keep tabs on certain users, you can add them to your buddy list. This allows you to see - at a glance - who's online and who's not. It will even let you know if they're in the public chat area (explained below) so you might join them. (Gray=offline, Orange=Online, Green=In Chat). Editing your account settings allows you to set privacy options in case you don't want others to know when you're online.

WHAT'S NEW

This is a special little link, but will probably become one of your most often used places on the site. Imagine how hard it is to keep tabs on all your favorite projects if you happen to be a member of five or more? Believe me, it gets hard. But clicking on "What's New" gives you a list of all content on the site that is either new or updated since you've visited it. The list is organized by project - and only lists those projects to which you're subscribed (either as a member or a manager).

New | Star Frontiers - Mozilla Firefox

Star Frontiers

GENERAL CONTENT [MARK ALL READ]

| Updated | Content | Type |
|--------------------|----------------------------|---------------|
| 6 hours 24 min ago | Zebulon's Guide Discussion | updated Forum |

25th Anniversary Edition Rulebook [MARK ALL READ]

| Updated | Content | Type |
|--------------------|--------------|------------------|
| 7 hours 34 min ago | The Timeline | new Forum |
| 7 hours 35 min ago | Timeline | updated Document |

Alpha Dawn Expanded [MARK ALL READ]

| Updated | Content | Type |
|---------------------|-----------------------------------|--------------------|
| 11 hours 49 min ago | Air-Powered Engine - Check it Out | new Forum |
| 13 hours 12 min ago | hot links to AD core rule book | new Forum |
| 1 day 4 hours ago | Alpha Dawn Expanded | updated Front Page |
| 5 days 4 hours ago | GV Tables posted | updated Forum |
| 5 days 13 hours ago | Arcar Altitude | new Document |
| 5 days 23 hours ago | Ground Vehicles | new Forum |

Online Ship Generator [MARK ALL READ]

QUICKLINKS

- Star Frontiersman
- Digitally Remastered
- Online Character Sheets
- Gamma Dawn
- Sourcebook
- Knight Hawks Online

DISC ROLLER

0 Corvus
0 Corjay
0 wDot
0 SmootRK
0 Mathuzelaz
0 JoeClient
0 Rum Rogue
0 black-dip

WHO'S ONLINE

Inspiral Lord
Rum Rogue
ONLINE IN CHAT

ADMINISTRATION

- Reported Violations
- Content
- Comments
- Forums
- Documents
- Users
- Create Content

40

NOVEMBER 2007

GENERAL CONTENT

Some information is not specific to anyone's projects. These types of content can be viewed and interacted with freely. Below is a basic list of the types of General Content you'll find on the site:

GENERAL FORUMS

These forums are organized into categories for general discussion of nearly any topic. Users can create a new topic of discussion or comment on anyone else's topics. Interacting with forums is pretty simple – most of you will already know how to use forums.

GENERAL FORUMS

| Forum | Topics | Posts | Last post |
|---|--------|-------|---|
| Game Talk | | | |
| Use this forum to talk about your current games, ask opinions of others about a game you're in, or exchange ideas with other Referees regarding a scenario you're planning. It will help others become encouraged to play by seeing that others are playing it too! | 14 | 252 | 5 hours 13 min ago by Imperial Lord |
| Links to Resources | | | |
| The internet is a big place, and it's full of wonderful resources we can all use for our games. Whether you come across a site that helps with role-playing in general, or provides map-making or character-generating tools, this is the place to discuss and share and critique. | 2 | 5 | 5 weeks 6 days ago by CleanCutRogue |
| Open Discussion | | | |
| This site is all about collaboration, and specifically for the Star Frontiers game. But we all have diversions and interests beyond this. This forum is a place for open discussion on any manner of non-game and non-sf-fi topics you want. | 6 | 42 | 5 hours 42 min ago by Cow Killis |
| Rules Questions | | | |
| Have a Star Frontiers rules question? Since no one person is an established authority on the game, everyone will have an opinion on an answer to your rules question or concern. Post any game-related rules question here, and let the community help address it. | 1 | 11 | 1 day 12 hours ago by Corjay |
| Website Discussion | | | |
| There has been a lot of work put into this website. But the development team is still improving on it regularly. If you have a vision of how something might be handled better or differently, or just have some honest criticism to lay on the feet of the developers, here is the place to do it. | 21 | 137 | 1 week 2 days ago by Corjay |

SUPPORT ISSUES

If something isn't working right on the site, or you would like to see a new feature, there exists a system of creating support issues. I will try to provide features requested, but some are more time consuming than others, and some I may not be able to implement. But I give serious attention to any suggestion, and am open to suggestions as to how to accomplish existing suggestions. You may comment on any support issue just as you could a forum.

CHAT

For now the site's using a third-party program, AddOnChat, that works quite well. However, it's limited in that we can't create new rooms or anything. It is a very robust javascript application, and hopefully you'll enjoy its use. When someone is in chat, there is an indicator on the rest of the site that shows it (see Layout, below). If you are working on a project that demands discussion between members, this is a good place to facilitate it. Heck – if you're bored and want to goof off in a chat room, this is a good place to do it. It is the eventual intent that the chat will become more robust and include more advanced features, hopefully allowing for an online gaming experience like that provided by some online RPG game management systems.

LINKS

This general type of content is for public sharing of links to resources others might enjoy. Links can be added by anyone who wants to. You can feel free to create a link to your own site if you too have RPG-related material the rest of the community might enjoy. Whenever people click on the "Links" tab at the top of the site, they'll be treated to a shuffled list of links we've all provided. There are already several links provided... I hope you add a few to source material you enjoy. If you find links added by folks for adult material, just click on the warning icon and it disappears... allowing a Site Referee (that's what I call an Administrator) a chance to review it and make a choice to delete it or re-activate it.

FEEDBACK

















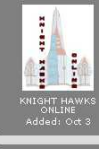

Like something about the site and don't want it in a public place? Click on the "Feedback" tab and let me know. This particular link is available even to users who aren't logged in to the site.

PROJECT LIST

Clicking on the "Projects" tab allows you to view all the details about all the projects currently in use on the site. You can view a "Full" list or a "Lite" list of projects. The full list tells you everything you need to know about the project, and gives links to all the important elements of a project (see Project Content, below). The Lite list just gives a thumbnail view of all the projects, all on one page. The site remembers which view you used last – so you don't have to set a preference anywhere.

[Full](#) | [Lite](#)

Click on a project thumbnail to get more information.

| | | | | |
|---|--|--|--|--|
|  25TH ANNIVERSARY EDITION RULEBOOK Added: Aug 14 |  ADVENTURES FOR THE IMAGINATION Added: Aug 15 |  ALPHA DAWN EXPANDED Added: Oct 10 |  CYBERNETICS HANDBOOK Added: Jul 29 |  STAR FRONTIERS ALPHA DAWN REMASTERED Added: Jul 31 |
|  FANTASY FRONTIERS Added: Aug 12 |  GAMMA DAWN SOURCEBOOK Added: Sep 24 |  KNIGHT HAWKS ONLINE Added: Oct 3 |  ONLINE CHARACTER SHEETS Added: Aug 6 |  ONLINE SHIP GENERATOR Added: Oct 13 |
|  ORIGINAL SF ART Added: Aug 15 |  RACES OF THE FRONTIER AND BEYOND Added: Oct 18 |  RAGNAR ANCHORAGE SHIPYARDS Added: Aug 12 |  RANDOM PLANET-SYSTEM GENERATOR Added: Sep 14 |  STAR FRONTIERS 2000 Added: Oct 22 |
|  STAR FRONTIERSMAN Added: Jul 29 |  STAR LAW CAMPAIGN BOOK Added: Aug 15 |  THE HOUSE RULES WIKI Added: Sep 14 |  ULTIMATE EQUIPMENT GUIDE Added: Oct 19 | |

SEARCH

The searching feature indexes all the content on the site. You can type in a word or phrase and the site will spit back everywhere on the site that word or phrase is used.

Want to read about cybernetics in the Frontier? Type "cybernetics" and hit the enter key. You'll see a lot of places where the word is used, with links to each!

PROJECT CONTENT

A project can be anything you can think of. It can be a work-in-progress for a new sourcebook (many are). It can be a gallery of images collected from around the net. It can be a coordination place for software being written – whether it's web-related or not. A project is a robust method of organization for site content, and you can use them for many versatile things.

A project is made up of many components, each of which is described in detail below. Some projects won't have all components, and some projects will limit your content access based on your membership level.

Once a project is created, the creator of that project becomes that project's Manager. A Project Manager has certain rights and privileges not available to a project's members. To become a Project Member, simply visit the project's front page and click the button to Request Membership. If you are not a member of that project, you may have certain project content restricted.

FRONT PAGE

A project's front page is an open canvas for the project manager to write details about that project. He can type what the project is about, provide links or descriptions, or put any content he desires. At the top of the project's front page is a Project Block, defining the basics of the project's permissions. The five stars you see in the upper right is that project's popularity, voted on by anyone who wishes to state their anonymous opinion. From this project block, you have links to access the other pieces of the project, described below.

FORUMS

Each project has its own dedicated forum, where people can discuss whatever the project is about. Please keep the content of the project-related forums on topic of the project; general content should go in the general forums.

DOCUMENTS

This is a special type of content for your projects. It's more versatile than a wiki, but shares a lot of the same uses. Documents are pages of text and graphics, organized however the editor desires. In many cases, the one editing the document pages will be the project's manager. But depending on the project's settings, it may be possible that anyone can edit the pages. The pages are edited using a wysiwyg editor similar to RTF editors such as Wordpad. Using this, you can use the Documents as a gallery, as a working document for a sourcebook, or as just about anything else you can think of. Since the pages are nothing more than html pages, you can turn off the wysiwyg editor and put any normal html or javascript code you'd like, allowing for programmers to get creative and use a project for clever code. Documents are at the heart of a project, and will undoubtedly get yet even more

treatment and features as time goes on. Check out the Documents of some of the various projects and see what's going on.

DOWNLOADS

Some projects will need a downloads section. This is a special place where members of the site may grab source material or finished projects. For example, the StarFrontiersman will be available for download from this location (they are already).

MEMBERS

This link allows you to view the members associated with the project in question. Project managers can use this page for some additional functionality – to send announcements to the project's members, to cancel user memberships, or even to ban users. The rest of the site just uses it to view his fellow project members.

SUPPORT

A project can also have its own private support issues section (just like the general support issues on the site). This allows you a place to tell a project's manager about his inaccuracies or typos – or request features that aren't present currently. The project's manager is allowed to set an issue's status ("will not fix", "fully resolved", "unresolved", etc.). The support issues system can also be used to divvy up responsibilities among members. Like most site content, support issues can have their own comment conversations under them.

COME JOIN THE REVIVAL!

I've gone on and on enough about the site. I sincerely hope to see you there! Come join us in an attempt to revive the fun of an old game, or just to hang out with fellow gamers. I look forward to collaborating with you!

CYBERNETICS HANDBOOK

| Topic | Replies | Created | Last reply |
|---|---------|-------------------------------------|-------------------------------------|
| ☒ Function Points and Levels | 4 | 1 week 6 days ago by Corjay | 1 week 5 days ago by Corjay |
| ☒ Would You Like Cybernetics RPG Materials? | 1 | 3 weeks 5 days ago by Corjay | 3 weeks 5 days ago by CleanCutRogue |
| ☒ Cyberpunk or Cyber Frontier? | 5 | 10 weeks 21 hours ago by Corjay | 4 weeks 3 days ago by Rum Rogue |
| ☒ Mood and Background | 34 | 10 weeks 1 day ago by Corjay | 6 weeks 1 day ago by Corjay |
| ☒ Cybernetics and Genetics | 7 | 6 weeks 3 days ago by SmootRK | 6 weeks 3 days ago by Corjay |
| ☒ Battle Rage | 20 | 9 weeks 4 days ago by Corjay | 6 weeks 6 days ago by CleanCutRogue |
| ☒ Column Shift Figures | 1 | 8 weeks 2 days ago by Corjay | 8 weeks 2 days ago by CleanCutRogue |
| ☒ Body Energy Mechanic | 5 | 8 weeks 5 days ago by Corjay | 8 weeks 4 days ago by CleanCutRogue |
| ☒ Maximum Implants Mechanic | 6 | 8 weeks 5 days ago by Corjay | 8 weeks 4 days ago by CleanCutRogue |
| ☒ Skills | 5 | 9 weeks 6 days ago by Corjay | 9 weeks 21 hours ago by SmootRK |
| ☒ Management | 8 | 9 weeks 4 days ago by CleanCutRogue | 9 weeks 4 days ago by Corjay |
| ☒ Freelance Law (Bounty Hunters, PI's) | 2 | 9 weeks 5 days ago by Corjay | 9 weeks 5 days ago by Corjay |
| ☒ Formatting | 2 | 10 weeks 3 hours ago by Corjay | 10 weeks 23 min ago by Corjay |
| ☒ I'm not a member but.. | 2 | 11 weeks 3 days ago by w00t | 11 weeks 12 hours ago by w00t |
| ☒ What Is Cybernetics? | 0 | 11 weeks 2 days ago by Corjay | n/a |
| ☒ Does this work? | 2 | 12 weeks 2 days ago by JoeClient | 11 weeks 5 days ago by Corjay |

CIRCLE OF FATE PART 2

By Auden
Reiter

CHAPTER TWO

Nixon held out his hands in a submissive manner. As the cyborgs moved closer, he continued stepping back toward the railing of the balcony.

"Stop moving," said one of the 'borgs. Nixon glanced over his shoulder and smiled.

"Easy, gentlemen," he said, "I'm just taking a walk."

Nixon gingerly stepped up onto the railing and stood, a little wobbly. The cyborgs darted forward and grabbed his legs. Nixon grabbed their jackets, a full bunch of cloth in each hand, then pushed himself backwards, leveraging both of them over the railing. There was a long moment of fearful weightlessness that Nixon was perfectly used to. The 'borgs flailed awkwardly as the signals racing to their biomechanical brains crossed with raw animal instinct.

A transport-sized skipflyer scooped Nixon into its open cargo bed. Pain shot through Nixon's back as he hit the transport, legs dragging over the side. The cyborgs scrambled to pull themselves from his legs to the cargo bed. The skipflyer's canopy opened and the Vrusk inside tossed Nixon a laser pistol. Nixon spun, burning a short burst into the first 'borg's face. The 'borg screamed and let loose. The second 'borg pulled himself up onto the skipflyer's bed. The Vrusk pilot rolled the skipflyer nearly ninety degrees and Nixon grabbed familiar cargo handles, kicking outward. His foot landed in the 'borg's chest. The 'borg toppled over the side, just barely grabbing onto the side. The skipflyer leveled out and Nixon peered over the edge.

"Wait..." said the cyborg. Nixon burned the 'borg's hand to nothing, melting a chunk out of the side of the cargo bed. The mountain of man and metal fell into the empty open space between skyscrapers. Nixon watched him fall five stories into someone's patio and land near his motionless partner. Nixon pulled himself into the passenger seat as the Vrusk closed the canopy.

"Murder so early in the day, Captain?"

"They'll live," said Nixon watching the patio slip into the background of the cityscape, "Probably."

"You are lucky that you had your beacon active. We now owe four hundred credits to the Herson's Bay Transportation Authority for disrupting an organized fly zone," said the Vrusk. Nixon looked at her with dismay.

"Keel't, one of these days you're going to admit that saving my life is actually worthwhile."

"Is that a thank you?" clicked the Vrusk. Nixon rolled his eyes.

"Yes."

The skipflyer sped out over the water and into the Herson's Bay landing fields as a light rain moved in over the city.

Hope on High was a converted Turnabout class heavy troop transport. She had two cargo holds, both half full, a personnel deck, and flight deck. She had an unusual variable geometry wing structure, the result of her original design. This made her capable of actual atmospheric flight, not just punching through the atmosphere on raw power, though she could do that if the need arose. Because of her multirole design, she was oddly shaped for a starship, a roughly aerodynamic stubby cigar with sturdy wings capped with powerful atomic engines.

Dom stood under the cover of the *Hope on High's* cargo door, under her nose to avoid the weather. Unlike most Dralasites Dom did not like rain, it made him feel like soup. He spent a few minutes extruding a third arm and flexing its fingers. His eyespots glided over the surface of his malleable face. The wet surface of the landing pad shone under the lights in stark grey tones. While Dralasite vision was incapable of translating color, it had the remarkable ability to interpret patterns. Dom watched the rain fall for long minutes, engrossed in the chaotic array of the ripples on the landing pad.

The air vibrated with the arrival of the skipflyer and its heavy shape caught the lights from the landing field. The skipflyer rotated its vectored thrust nozzles and slowed into a soft approach. Dom smiled inwardly. Keel't was at the helm. It was obvious from the gentle way she guided the machine down, across the landing pad and kissed the *Hope's* cargo deck with barely a sound beyond the engines. She was an artist.

Nixon jumped out of the skipflyer as it came to a stop. He spotted Dom who shuffled toward him.

"Almost dead?" asked Dom in a low rumbling voice. Nixon spread his arms and smiled.

"Almost doesn't count," he said, and embraced the Dralasite. Dom patted Nixon's back.

"Anything I should know?"

"Yes, I'll fill you in on the way to Yasko's."

"That bad?"

Nixon stopped and glanced around.

"Where are the twins?"

The two Yazirians stepped out from under the *Hope*, neatly avoiding the cargo ramp. Nixon looked at them a moment then tossed a credit stick at them. Yan Ci looked at the stick and back at Nixon.

"We will check this."

"Fine," said Nixon dismissively and turned to Dom. The twins looked at each other and slowly stepped aboard.

"Grab a fresh parabattery and get the skipflyer ready. Keel't?"

The Vrusk had made it half-way up the steps to the upper decks, half her eight legs on the nearest wall.

"We have a job. Start doing jumpcalcs for Ceta Prax."

"Ceta Prax. In the Xygap nebula?" asked Keel't evenly. It was barely a question.

"That's the one," said Nixon as he turned to the skipflyer. Dom dropped a new parabattery into the skipflyer's engine, locked it in, and closed the engine hood. Makraapoza Keel't watched the skipflyer, barely cool from its previous journey, spin awkwardly out of the cargo deck and into the rainy sky.

Yasko Vane was an Ifshnit of athletic build and quick mind. On either side stood two Humma body guards all missing their left eye. Rumor had it that this particular group ritually mutilated themselves to better focus on fighting as Humma believed that the right eye was for battle.

Yasko took a deep drink from a simple metal cup and regarded the two brothers before him. Human and Dralasite. As a rule the races liked each other, but these two shared a special bond. It confused Yasko, but he appreciated solidarity.

"Nixon," he said gently, "I already have a buyer for your escape pod. Why should I give it back to you?"

"I have information," said Nixon easily.

Yasko's inner lids blinked, shading his eyes black for a moment. It did not have any meaning, but to Nixon the act always seemed ominous. Yasko said nothing.

"I have a job that will take me to Ceta Prax. A university hired me. They are looking for an artifact."

"It's not the first time an artifact has been found."

"I didn't say found, I said looking."

"Artifacts are all over."

"But only a handful have worked, and even then—"

"Yes," said Yasko, "You've your point. What university?"

"My escape pod?"

"Yours. University?"

"Argos."

"And the artifact?"

"That's extra," said Nixon.

"You owe me—"

"And I'll pay you another seventeen percent of what we get when we return."

Dom crossed his three arms. Yasko took another drink from a buxom human female wearing a heavy collar.

"Twenty."

"Twenty and you pay fuel, docking fees, and maintenance."

"Maintenance before or after?"

"Before, Yasko, I'm not a thief."

"Everyone's a thief, human, but you've got me intrigued. Done."

"The artifact is very, very old," said Nixon at once, "and something they want kept quiet."

Yasko scratched his beard.

"Okay, but you see me as soon as you land," he said.

"I will. I have one more question."

"Of course you do."

"I was attacked today. I want to know by who."

"By whom. Do you even speak your own language? Show me."

Nixon pointed to Yasko's computer.

"May I?"

Yasko waved his hand. Nixon slipped a datacard out of his chronograph and into Yasko's metacomp. It took a moment to flip through the data on Nixon's card.

"No one I know has got you down for assassination. No one's paid the tax."

Dom could not help himself.

"Tax?" he asked.

"Assassination tax," said Yasko with a smile, "killing stirs up trouble all around. I make blood hungry parties pay to cover my expenses to smooth everything out again."

The holopanel flickered to life with an image of the two men. The picture had been taken from the hip with Nixon's chronograph camera and was a bit blurry. Yasko narrowed his eyes. His black inner lids fluttered.

"Cyborgs?"

"Military grade," said Nixon, "Nice stuff for all the good it did them."

"Doesn't ring a bell," Yasko grunted "and I'd know."

"That means it's either military or upper corporate."

"The only two that could afford that kind of slick. But, the megas don't operate black in my city anymore."

"And the military has plenty of other ways to get a hold of me."

"We could talk all day-"

"Which means either you're lying to me or..."

"Nixon," Yasko took a sip of his drink, "don't start getting insulting, not when this conversation is going so well. Ask your little brother there."

Dom did not make a sound.

"Sorry," said Nixon.

"You bet you are," spat Yasko, "especially since you've narrowed it down to money."

"Somebody rich enough to hire the 'borgs-"

"But stupid enough not to pay taxes."

Outside in the skipflyer, Nixon eased the machine off the ground and turned to Dom expectantly. Dom burble-hummed a little and his eyespots slowly shifted across his face.

"He's not lying about the cyborgs," Dom said finally. Nixon waited. Dom was always slow to voice his findings, but had preternatural insight on the affairs of other beings.

"Obviously, he's much more interested in the artifact than he expressed." Dom intertwined the fingers so all three hands in an impossible quilt, they grew and knotted unconsciously. Even after years of experience, Nixon still wondered if Dom would be able to get his fingers free.

"I think he knew about it. Knows about it. Not from or through us, but another angle. You didn't give him much, but he was happy, like he was confirming something. Something... it's odd, I would have expected him to send a beacon or "passenger" along with us."

Nixon nodded.

"He'll find a way," he said with a sigh, "smart little trag, that one."

Nixon angled the skipflyer toward the seaports; the best place to buy supplies this time of day. Dom pulled his hands apart with ease and reached behind the seat with his third arm. He pulled a slim portacomp onto his lap.

"Here's what I've found on our new employers." He worked the comp's interface with fluid fingers.

"Doctor Matteredly Wen. Originally from Gollywog. Is a respected professor and researcher. Lost family in Second Sathar War. Heads up several departments including some related to military research. All public knowledge.

"Doctor Saiya Mave- oh..."

"What," said Nixon glancing away from piloting to see the screen.

"Well, this is the first time I've seen a picture."

"And? What?"

"You're in trouble," said Dom examining the beautiful night-skinned doctor. Nixon opened his mouth to protest, but his brother knew him too well.

"Don't I know it," said Nixon turning back to the controls.

The skipflyer pulled onto *Hope on High's* cargo deck some time later. The waiting twins began unloading the cargo boxes packed into the skipflyer's bed as Dom rolled out of his seat with odd grace. Nixon looked over the cargo deck with a distant stare.

"Dom," He said over his shoulder, "they'll be here soon. Do your thing."

Dom nodded with an overdone Human gesture and pulled out his portacomp, taking a seat amongst the random cargo crates.

Nixon climbed the metal stairs to the second deck. He passed through the common area and climbed the short set of steps to the flight deck. Keel't was working at the engineering console. Nixon slipped into a nearby chair.

"I'm home!" said Nixon. Keel't shifted her body some, working both hands on separate consoles.

"I heard you arrive."

"What are you doing?"

"Recalculating jump data."

"Ah. The escape shuttle?"

"Yes. You should have-"

"I got it back."

Keel't's hands stopped and her head swiveled a little to bring him into the wide field of vision of her compound eyes.

"Are you sure?"

"Am I-" Nixon started with hurt, "Yes, I'm sure! It'll be here... in a few... hours..."

He trailed off under her stare. Keel't turned back to her work, her hands flew over the holographic displays feeding the navigational computer information by both touch and gesture. Nixon gave up.

"You have the coordinates?"

"Dom sent them while you were enroute."

"Good. Our *paying* passengers will be here soon. Try to be polite."

"I will do my best," she said with all manner of Vrusk sarcasm.

"Fine," said Nixon.

Her head stayed still, but she lowered her body to the deck a bit. It was never easy to read Vrusk body language, the lack of expression was especially confusing. But Nixon had known Keel't for years.

"What?" he asked.

"You would not listen if I spoke, Captain."

"Why do you always say that?"

"Because it is true?"

"Just say what's on your mind, girlbug."

One of the consoles beeped with an error as Keel't lost concentration. She hated that expression. It was just so... nymph.

"Ceta Prax is dangerous," she said finally.

"I know that."

"I checked the public logs for the area. I found records of piracy, corporate espionage, and occasional military interventions."

"That sounds like our usual company."

"Most of that has been since you were there."

"What are you implying?"

"I am not implying, Captain, I'm saying that whatever you stirred up there those years past still has not settled. It is the last place *you* want to be, never mind the rest of us. You cannot--"

Nixon stood up. Keel't had no trouble reading human body language. Their skin was like the parchment of a scroll, every emotion written to see. Captain Nixon was angry, confused, and afraid. But there was no changing his mind.

"We're going," he said and left the flight deck. Keel't watched him storm out.

"Of course we are," she said to the empty room.

The *Hope's* passengers arrived minutes after Nixon left the bridge, but he was in no mood to greet them. Dom watched alone as a heavy transport pulled under the Hope's nose and the doors sprang open, front and back. Dom motioned to the Yazirians.

"More cargo?" Pelot snorted, "I thought we were--"

"You're paid is what you are," said Dom coldly. Pelot narrowed his eyes at the Dralasite, but his Yan Ci's firm hand kept him moving toward the transport.

Doctors Wen and Mave were dressed in worn jumpsuits with faded, mismatched mission patches. Mikal was wearing a thick bodysuit and tight jacket. They all had several harnesses packed with a variety of tools and gear slung over their shoulders. Dom noted the clothes and personal equipment: This trio was more experienced than most with space travel.

As the approached, Dom focused on Doctor Wen and made a Dralasite gesture of respect, requiring at least three limbs.

"Masters. I am Brushia Moomo Shewodom, graduate of Huindar Academy. Welcome to our craft. I will be your liaison on this journey. Do you have any questions before we begin?"

Dom used the word "Master" with no other inflection but respect. Scholars of sufficient rank were considered masters of their knowledge. For the Dralasite, it was a title of admiration, not superiority.

Doctor Wen made the Human equivalent of Dom's gesture.

"Guurho humvrrar, Brushia," said Wen precisely. Dom nodded, creasing his face with the uncanny replica of a human smile.

"Well said, Master Wen," said Dom, "Thank you for the courtesy of matching tongues."

"Of course, Brushia."

"Please call me Dom. I prefer it. It's what Captain Nixon calls me."

"Oh? Of course," but that would mean that the Captain... Wen stopped, unsure. Dom nodded a bobbing Human nod.

"Yes," he said, "Captain Nixon and I are brothers of a sort."

"That is a rare relationship outside of the Dralasite."

"He has earned it."

Doctor Mave looked back and forth between the two, slightly bemused. Dom gestured up the steps.

"Shall we?"

The four climbed a tall set of steps out of the forward cargo hold to the personnel deck where they found themselves in a common area decorated with matching couches and a bookshelf of old-fashioned paper books, strapped into a book shelf. A battered autogalley stretched across the back of the room. Keel't was standing next to the autogalley, near a hallway leading aft. Nixon was lounging on one of the couches. He glanced up at the bustling passengers.

"Put them in the back, Dom," he said, going back to his book. Mave rolled her eyes and Doctor Wen chuckled.

"We will stay out of your way, Captain," at least until we make planetfall."

Nixon let his book fall onto his chest and looked over his paying passengers.

"Doctor, you look like you've done this before," said Nixon, "I just- what are you doing?"

Mave had stopped listening to Nixon and was sniffing the air. She listened to the silence that stood after Nion's question and frowned.

"You've got a bad atmosphere catalyst near here," she said. Nixon grinned.

"Not likely. We just had the ship maintenanced."

"Regardless," Mave said, hoisting her bag higher onto her shoulder, "I can hear the spinner bearings giving out and it smells like bad eggs. I give it a week tops." She lugged her belongings to the hallway in the back of the room. Doctor Wen and Mikal followed without comment. Nixon chuckled until he met Keel't gaze. He stopped smiling.

"I like her," said Keelt, "And she's right."

Nixon tossed his book onto the couch and left the room via the forward stairs. He made his way passed the stacked cargo boxes to the rear hold. Nixon opened the thick hatch and looked around cautiously. The rear hold was stacked with older cargo crates and miscellaneous equipment Nixon had found it difficult to part with either because of paranoia or nostalgia.

A pair of goggled eyes peered out of the shadows from the high ceiling. Orina Thate was laying in a rewoven cargo net near the secondary atmosphere processors. Despite her wild look and odd smell, she was Human. Her clothes were as dirty as she was, but all of her equipment was as clean as it could be, including her ever-present earpiece, which functioned as both speaker and input device. She was watching Nixon, and mumbling to the ship's computer. The computer interpreted her subvocalized commands with ready attention and code languages danced across three paper-thin screens suspended over her.

"The Vrusk is calculating jump coordinates based on an outdated mode," said Orina.

Nixon tried not to jump at her voice. He had yet to find her before she spoke and it bothered him. A lot about Orina bothered him.

"Listening in, were we?" He said, trying to sound flippant.

"Always."

Nixon choked back his disturbed response. This was what she did, he forced himself to remember. This was why he kept her aboard.

"Good, can you give me the feed on the private quarters," he asked, "our guests?"

"A little eavesdropping? She's very pretty... I guess."

"Just give me audio."

There was a short scratch of static on hidden speakers, then...

"... we can't tell him. I want this to go as smoothly as possible. His kind."

"Mave, you have to get used to working with 'his kind.' There are things we cannot do under sanction. Things that will make a difference. Working with Captain Nixon allows us the latitude to make that difference."

Nixon frowned.

"I bow to your wisdom, doctor," said Mave, "I just wish that the sanctioning outline gave us more freedom. This ship."

"This ship was rescuing soldiers from Outpost retreats before you were born, doctor, she'll get us where we're going and back. Twice if need be."

"Sorry, I'm just not... this whole project reminds me of home. That's all."

"It's okay. I'm here. And we'll all be sitting in fat grants once this is over."

"Turn it off," said Nixon, "Close audio."

Orina shut the speakers off, but continued to listen through her earpiece.

"Do you think she's pretty?" Orina asked.

"She's okay."

"She's got that ancient look," said Orina, to no one in particular, "I prefer something more current."

Nixon glared at Orina for all the good it did him, then he sighed.

"We're going to Ceta Prax."

"Why do you, all the time, tell me things I already know. You think you would understand how connected I am by now."

"Some things should be said out loud."

"No. Everyone should share directly. That way there's no miscommunication."

"We're going to Ceta Prax."

"Are you going to run away again?"

"Not this time. There's nothing left to run from."

"The fractal of life is too endless to say that. Why would you say that?"

"My... fractal ended when the Dom Majesty died. At least the part that concerned Prax."

"You don't understand," Orina turned back to her work, "Why do they never understand?"

[To be continued...]

EDITOR'S PLEA...

We Need Illustrations!

I know there are a lot of you out there who can draw – even I can a little but my talents aren't great in that department. I'm seeking folks who can generate new Star-Frontiers art. The great stuff from Larry Elmore and others that filled the pages of the core rules, supplements, and articles is part of what made me love this game... but sadly there's few people who can bring original illustrations of Vrusk, Dralasites, and Yazirians to the table.

For this issue, I would have provided illustrations of this episode of the Circle of Fate (I wanted to have an image of Nixon's scuffle with the two well-dressed cybots... or even of Orina's head poking out from behind heavy machinery in the netting in which Nixon found her.

So please... help keep the vision of Star Frontiers alive! If you're a professional illustrator and don't want to do it just for the recognition – at least let me know you're interested and what you'd charge. I'm not loaded but I try very hard to keep this webzine of professional quality (after being disappointed several times by PDF downloads I actually paid for!)

C.J. Williams has done most of the illustrations so far – and I've done the gear and vehicles... but I'd love to provide much, much more.

Please contact me at Referee@StarFrontiersman.com!

YEZHA

BASIC INFORMATION

Race: Yazirian
Gender: Female
Age: 20years
Handedness: Right
Height: 2.0m "Below Ave"
Weight: 45kg "Lean"

ABILITY SCORES

STR/STA: 35/45
DEX/RS: 45/45
INT/LOG: 55/55
PER/LDR: 60/60
Initiative Modifier: +5
Punching Score: +2
Ranged Weapons: 23%
Melee Weapons: 22%

MOVEMENT

Walking: 10 m/turn
Running: 30 m/turn
Hourly: 4 kph

RACIAL ABILITIES

Battle Rage: 5%.
Night Vision: But -15 to all actions in full light.
Gliding: Can glide 1m forward for each 1m dropped.

SKILLS

Primary Skill Area: Biosocial
Medical: Level 1
Psycho-social: Level 1

BACKGROUND

Yezha was born on Hentz (Araks III), the youngest daughter of a Templar of the ruling priest caste (see Star Frontiersman #2 [Mar. 2007]). She was raised from the cradle to follow in her parents' footsteps. She excelled in her theological studies, and her natural charm and beauty could dazzle even the most jaded of hearts. When she came of age, Yezha's parents sent her to Onehome to finish her formal training, and that's when the troubles began.

While studying at seminary in Onehome, Yezha discovered she also had a natural talent for the arts of healing. Fascinated by the connection between wellness of mind and spirit and wellness of the body, she took up medicine alongside her religious training.

It was in medical school that she met Gareth Tyn, the human son of a trader and one of the exceedingly tiny non-Yazirian minority on Hentz. Gareth was a socially awkward young man who was being forced through medical school by his father. His natural talents lent themselves better to music. Yezha took pity upon Gareth and offered to tutor him, in exchange for him singing and playing for her.

Perhaps it was Yezha's relative naiveté and beauty; perhaps it was Gareth's music and loneliness; perhaps it was fate. Yezha never expected that she could fall in love with a human, but she did, and Gareth was knocked completely head-over-heels in return. For months no one suspected anything more than a scholarly relationship between the two of them, but then Gareth slipped and kissed her in public, and it was all over.

The scandal broke in the media the very same day. The priesthood was furious, and the Tyn cartel were ruined on Hentz. The cartel fled the planet in a single week, and Gareth barely survived an assassination attempt. Yezha was summoned home by her father, but in a startling act of impulsive defiance, Yezha hid away in a Tyn cargo crate, not knowing where she might end up.

When she arrived in the Athor system eight days later, Yezha was near



By C.J. Williams

death from lack of food and water. When her crate was opened up she was taken to a hospital, and during her recovery totally lost track of Gareth. Under questioning she gave a false name. With the skills she had learned back home she was able to get a job at the hospital and save up enough money to make transit to Prenglar, beginning her search for her lost love. Her search is complicated by the fact that if she is discovered by agents of either the Family of One or the Tyn cartel, she could be in very grave danger indeed.

PERSONALITY

Yezha is a bright and brilliant young woman whose natural charm and empathy allow her to easily make friends, or lie with great success. Her skills with interpersonal interaction supplement her training to make her an effective medic, and her natural impulse is to help anyone in need that she may encounter. She is somewhat headstrong, believing that her success in school and in escaping her family are indications that she can achieve anything she puts her mind to -- and she's most likely right. Everything Yezha does, she does to further her goal of finding Gareth, no matter the difficulty, but her priestly background and medical training have made her unwilling to kill.

APPEARANCE

Yezha is a stunning beauty with fine, pale golden hair and hypnotizing golden-green eyes, attractive not only to Yazirians but also to some humans. She is somewhat shorter than average for an adult Yazirian (still a full two meters tall, towering over most humans) and a bit on the slender side. She sometimes uses footwear with elevated heels to offset her below-average height.

She tends to dress in green and black accented with white, though she can often be seen wearing red jewels of various sorts. Yezha has a penchant for wearing detached sleeves on her arms to match her body outfit, and occasionally adds gloves. She is meticulous about caring for the hair on her head, much more so than a typical Yazirian (an affectation she picked up while dating Gareth). When she can she keeps her goggles elevated, resting on her forehead rather than over her eyes.

EQUIPMENT

Electrostunner
 Medkit
 Doze Grenade
 Tangler Grenade
 Chronocom
 Sungoggles

STELLAR ERRATA

By C.J.
Williams

Editor's Note: Okay, I'm not perfect. Sometimes I get stuff wrong. C.J. Williams noticed some errors on my part (and a few on his) in his articles, and wanted to print some errata. I have no ego (I have children - once you change a diaper you lose all dignity) so I step aside to provide him this forum. If you have noticed glaring inaccuracies in one of your articles, (other than simple spelling or grammar) and want a reprieve, send it in and I'll be sure to print it somewhere in the next issue. This article also includes a Q&A session C.J. had online at www.starfrontiers.us with other members.

BUYING AND SELLING

The article Buying and Selling (SFman#06) can be used in conjunction with the Dragon Magazine articles "Rare Wines and Ready Cash" by Tony Watson in the January 1985 issue, page 82, and "'Tote That Barge: A Short Guide to Interstellar Economics" by Matt Bandy in the March 1986 issue, page 80.

The Hagglng subheading can be used in conjunction with the Hagglng skill from Zebulon's Guide.

In the article Buying and Selling, read "Prenglar" in the place of "Pan-Gal" in all places where it appears.

STARFLIGHT Q&A

Q: I found your article on options for fighter & bombers very interesting, and had some question/comments. Did you consider something along the lines of a 'Hardpoint' (kind like 'weapon pod' as listed in the Dragon 'Tanks a lot') article? Could be conceived as internal or external, and even external should take X amount of space IMO (wiring, structure reinforcement, etc) - then purchase as many 'hard points' for a vehicle as the number of missile / bombs that are desired to be carried.

A: I'm glad it sparked your interest. I'll answer your questions to the best of my ability. Sadly, I did not have a chance to develop the missiles very well, so your questions below will be first considerations. I prefer simplicity over complex rules for space allotments. If you wish to develop this aspect, feel free. There's always plenty of room for more articles in the Star Frontiersman. All weapons in the article are considered externally attached, except for bombs and starbursts, and has no bearing on space. The Armament Table shows the number of the type of weapon that can be attached to a fighter. See below for identification of the tables in that article.

Q: For multi-target targeting, how about having to purchase multi-target tracker for each target above 1 that one wants to target simultaneously.

A: Again, I prefer simplicity, that's why I provided the system packages. Feel free to develop this as you like. The Fighter article is for generating ideas and providing a base from which to operate. Each GM has full authority to make

changes to any rules system as they see fit. My keeping it simple, it leaves more room for game play and less need to track the number of tracking capabilities you have or tracking things by sheets and tables.

Q: There doesn't appear to be any difference between the Redeye and Guided Missiles besides tracking system. As a thought, how about one (Redeye) being cheaper/shorter range/more maneuverable/less damage than a larger, more full-features missile? And as I think many current missiles have both IR and Radar components, maybe include both sensors in both missiles? (And maybe a higher ADF for both? Esp. if go by the rule that total speed increases half the applied acceleration)

A: As mentioned above, this is an unfortunate effect of not having time to develop them. After watching the first Charlie's Angels movie recently on cable, I realized that a missile could easily be equipped to switch between guided and infrared modes, so if I had thought about it before, I would have just made them the same thing with options between guided and infrared.

Concerning range, it is often a common mistake for people to judge future weapons based on weapons today. When you look at the great advances in weaponry over the past 20 years, let alone over the past century, you realize that range and accuracy has increased substantially, so it is safe to assume that range will continue to have substantial gains as new technology and greater fuel efficiency becomes available.

On a related note that I'll, I also don't subscribe to the artificial gravity theories in Star Frontiers. I use my own speculations regarding it. One of those is that I think gravity and anti-gravity understanding will help almost every technology, including propulsion. That technology will allow missiles to travel swiftly and much, much farther distances, particularly in space.

Now, you ask about a higher ADF, but speak of a lower range. Currently, modern missiles travel at about 800 kph. That means it would take a full round just to go 133 kilometers. In a 60,000 km hex in a 10 minute time scale (standard KH) this wouldn't even equal a quarter of a hex. So, as a result of the speed needed to go 1 ADF (at least half a hex or 30,000 km), it must travel 225 times faster (or 180,000 kph). At that speed, its range would be greatly increased, particularly in space. However, if you look at the article, Shades of Motion in 3-D in Starfrontiersman #6, you'll find a more realistic scale, at which the speed, range, and maneuverability makes more sense. Remember too, that the faster you go, the harder it is to change trajectory even, and especially, in space.

Q: Have you thought about the impact to larger ship design? If 12 missiles can be carried on a HS:1 fighter, and 20 on a HS:2 bomber, how many could be carried on a frigate or light cruiser, and what does this do to balance?

I personally like the idea of large ships carrying more missiles, but it is a fairly large change to the KH universe. NOTE: I didn't see a mass or m^3 volume listed for either of the missiles in the article, so I assumed 12 could be carried by the 16,000kg light military fighter.

A: Unfortunately, some labels were removed from the tables in my article, so there may be some things being overlooked. See below for a complete list of adjustments for that article, including table names.

The Armament Table I mentioned above defines how many weapons can be carried by each type. The Light Military Fighter can carry 2-8 missiles. These missiles are quite small in comparison to weapons carried by larger ships, and would be impractical for ships of those sizes. These missiles are meant to be comparable to missiles carried on modern fighters, and modern fighters often carry a large assortment of weapons.

Yes, a frigate or light cruiser could conceivably carry hundreds of such missiles, but they would prove largely ineffective against other ships of comparable size. If you do decide to use them, I determined the number of weapons a fighter can carry based on the weight the fighter could carry fully loaded and in association with its other weapons. If you maxed out a fighter with the maximum number of each weapon it is allotted to carry, that would come close to its maximum allowed weight when coupled with the best system package. So, feel free to add as many missiles as you like to larger ships, just consider the weight of each missile and the allowance of the vessel.

Also, a vessel in space too large to fly in an atmosphere need not be equally constrained by weight. I added the missile masses to the table below. Feel free to consider the guided missile to be able to switch between infrared and guided modes.

Q: In general, to me the # of missiles carried seems a bit high, given that a KH ICM takes $5m^3$, has a range of 0, and is only effective against Rockets / Missiles. I would expect the new missiles to be a lot larger (longer range and explosive.) 50% longer range than an Assault Rocket, and averages 9HP damage (vs 14 for the Assault Rocket) going by KB damage levels. (And I also think a range of 60,000km seems high as well.) FWIW, an F14 (HS:2 in SF) could barely carry 6 Phoenix missiles, which had a range of 100+k. Especially if you play with hex scaling as you mention in Starfrontiersman #6, and hexes are only 20k. In general, I've been thinking a lot about scaling back the range of Laser Pistons to 1 or 2 (KH scales), and then scale the new weapons accordingly (would mean fighter need to be up close and personal in KH 10k hex scales.)

A: Actually, F14's are one of the many jets I studied in preparation for this article. In actuality, an F14 would compare more to the Light Military Fighter, instead of the Heavy Military Fighter, so in the article, would actually hold 2-8 missiles instead, so that is around the range you have spoken of. Also, a space-capable fighter would be sturdier than an F14 so could conceivably hold a couple more

missiles. I think you're on the right track with your thinking about Laser Pistons. Fighters are definitely a close range and pursuit vehicle; that is what I kept in mind when writing the article.

Q: Maybe include the IR jammer from KH/'Tanks a lot'?

A: I had considered using that article for study, but with the time constraints, I had to cut it from my reading schedule, so anything you can use in that, feel free. I'm sure there's lots of material in that article that could be beneficial.

Q: instead of having vehicle HS 1 - 12, did you consider sub-sizes of the existing KH HS? 1.1, 1.2, 2.1, 2.2, etc? Could use longer term with various Hull Sizes to differentiate the +- 25% variance allowed under the rules.

A: Technically they are subsizes of KH. Scaling doesn't lend itself to a 1-10 range. I was also seeking simplicity. A decimal scale would be too finite for my tastes. I felt the scale I chose satisfactorily divides the sizes within an acceptable differential that seems to me to be 'just right'. Also 1-12 does bring it to 30. I had listed 11 sizes, not 12, but I have revised the table below. Everything in the article is up to manipulation. I encourage you to adjust the numbers as you like.

Q: In addition to the individual articles in the frontiersman, do you keep a consolidated document of articles related to sf:KH? [It] Would make things easier to find. Again, thanks for all the work that you put into designing the system and writing it up.

A: Actually, I've been working on several supplemental books for the game and will be including these rules and the Shades of Motion rules in the Delta Dawn Large Scale Tactical Rules supplement. You're welcome and I appreciate your looking the article over. It is all up to the reader whether they see it as something they want to use. I haven't had opportunity to test the system from either article, so feel free to make changes and suggestions and let me know what you come up with or even write your own article if you are inclined. It would be the ultimate compliment to me if anything from either article gets used in perpetuity.

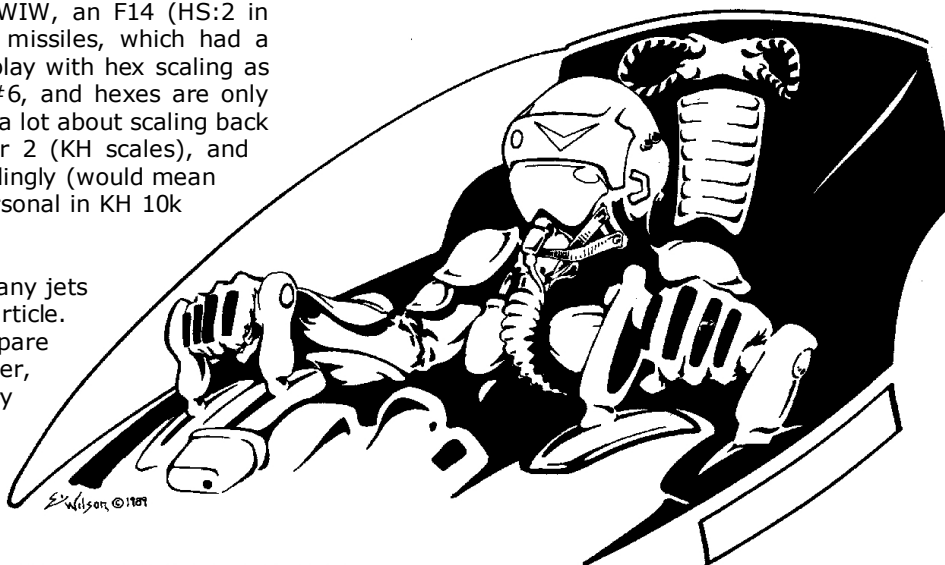

COPYRIGHT © 1989 BY EDDIE WILSON - ALL RIGHTS RESERVED

Whereas I chose to stick with the original Star Frontiers Knight Hawks rules, there are also the Knight Hawks Vector rules that you can look into. Despite assertions to the contrary, it significantly alters the Knight Hawks rules to supposedly be more scientifically accurate. While I am not a fan of those rules, you may find them more to your liking, though changing trajectory suffers considerably under those rules, thus maneuverability is at a premium, so judging by your preferences as stated here, it may not be the best for you, but it's out there all the same, just to let you know about the current options.

Thank you for taking the time to write me and ask these questions. I would be glad to answer any more questions about these articles.

STARFLIGHT TABLES

The article Starflight in issue #5 was a first article of its kind by this author and took a lot of research and careful table development. As a result, some mistakes were made. Additionally, the names of all but one of the tables unfortunately did not make it into that article (Though I never gave names to the first two tables), leaving the reader to guess at what the tables were for, so I'll state the names here with brief descriptions and any corrections so that you can get a better understanding.

VEHICLE SIZE TABLE (REVISED)

| Frame Size (KH) | Aerospace Mass (MT*) | Engine Size |
|-----------------|----------------------|---------------|
| F1 (H1) | <.05 | Standard |
| F2 (H1) | <.1 | Standard |
| F3 (H1) | <.2 | Standard, A1* |
| F4 (H1) | <.5 | A1 |
| F5 (H1) | <1 | A1 |
| F6 (H1) | <2 | A1 |
| F7 (H1) | <5 | A1, A2* |
| F8 (H1) | <10 | A1, A2* |
| F9 (H2) | <20 | A2 |
| F10 (H2) | <50 | A2 |
| F11 (H2) | <100 | A2 |
| F12 (H2) | <200 | A2 |

*Metric Tons

The table on page 9 in that article is the **Vehicle Size** table, outlining vehicle size and weight along with the engines it can carry. Instead of writing V Size before the size, instead write the frame size as F1, F2, F3, F4, etc., while writing Knight Hawks hull sizes as H3, H4, H5, etc. The masses of the sizes also needed adjustment. Note the revised table.

The table on page 10 is the basic **Fighter Table**, with everything you need to know about the fighter you are purchasing.

The first table on page 11 is the **Engine Table** and tells you everything you need to know about the engines and fueling them. There was a typo in the Starflight article about the cost of **Plasma Drive fuel** costs. It should read **10xV Size/2** on both A1 and A2.

The second table on page 11 is the **Armament Table**, and tells you how many of each item can be carried on the type of ship or whether it can be carried at all. A fighter can carry all the weapons listed on its row at the same

time. Meaning that a Light Military Fighter of vehicle size 7 can carry 8 missiles, 4 bombs, 4 starbursts, 2 Assault Rockets, and any one of the four beam or P.G.S. weapons. Of course this all depends upon the fighter's design and Referee's allowance. The discrepancy between the qualifying vehicle size of the Dual Piston and Bolt Launcher of the Armament Table and the Minimum Vehicle Size of the same weapons on the Weapons Table are due to that the Weapons Table shows what they can be attached to, but may require penalties (Referee's discretion).

The third table on page 11 is the **Weapons Table**, and tells you everything you need to know about the new weapons provided in the article, plus the Laser Piston from Dragon Magazine. Further considerations and research into missiles shows a need for more information and corrections. I also forgot to include certain details for starbursts and missiles in the article. The revised starburst and missile stats are as follows:

WEAPONS TABLE ADJUSTMENTS

| Type | HDR | | | Volume | Mass | Cost |
|----------------|-----|-----|-----|------------------|------|---------|
| | FP | Mod | DTM | | | |
| Starburst | 2 | -- | -- | 1 m ³ | 18kg | 1,000Cr |
| Redeye Missile | 2 | +30 | * | | 64kg | 1,500Cr |
| Guided Missile | 3 | +50 | -20 | | 88kg | 2,500Cr |

* Automatic drive damage: -ADF=damage/10 (round down)

The first table on page 12 is the **Missile Table**. This table is needed to help you know how fast you need to be traveling to get out of the way of the missile. Multiply times 10 for each speed value below SV 6 (See Shades of Motion in 3-D in Issue #6 for more details).

The second table on page 12 is the **Combat Modifier Table**, showing combat modifiers provided by the targeting systems.

The third table on page 12 is the **System Package Table** and gives you all you need to know about installing system packages. The volume of **System Package V** should read **29-38m³**.

The last table already has a name and should be familiar.

QUESTIONS?

I would also be interested in hearing how the Starflight article and the scaling and 3-D movement in SFman #6 works for all of you, if at all. Both articles excited me to write and I tried my best to take every calculation into consideration, and I studied everything from WWII prop planes, jets and bombers to the space shuttle and even satellites, but not being a physicist there's no guarantee that the end result is accurate, but hopefully it is very playable. It is my sincere hope that my relying upon known figures and updating according to what could be expected within two to three centuries of progress has kept everything within the range of believability.

Try out the information you find in Star Frontiersman articles and ask questions. If you have any questions for any article published in the Starfrontiersman, please, feel free to contact the author c/o Bill Logan at his email: referee@starfrontiersman.com.

NOVEMBER 2007

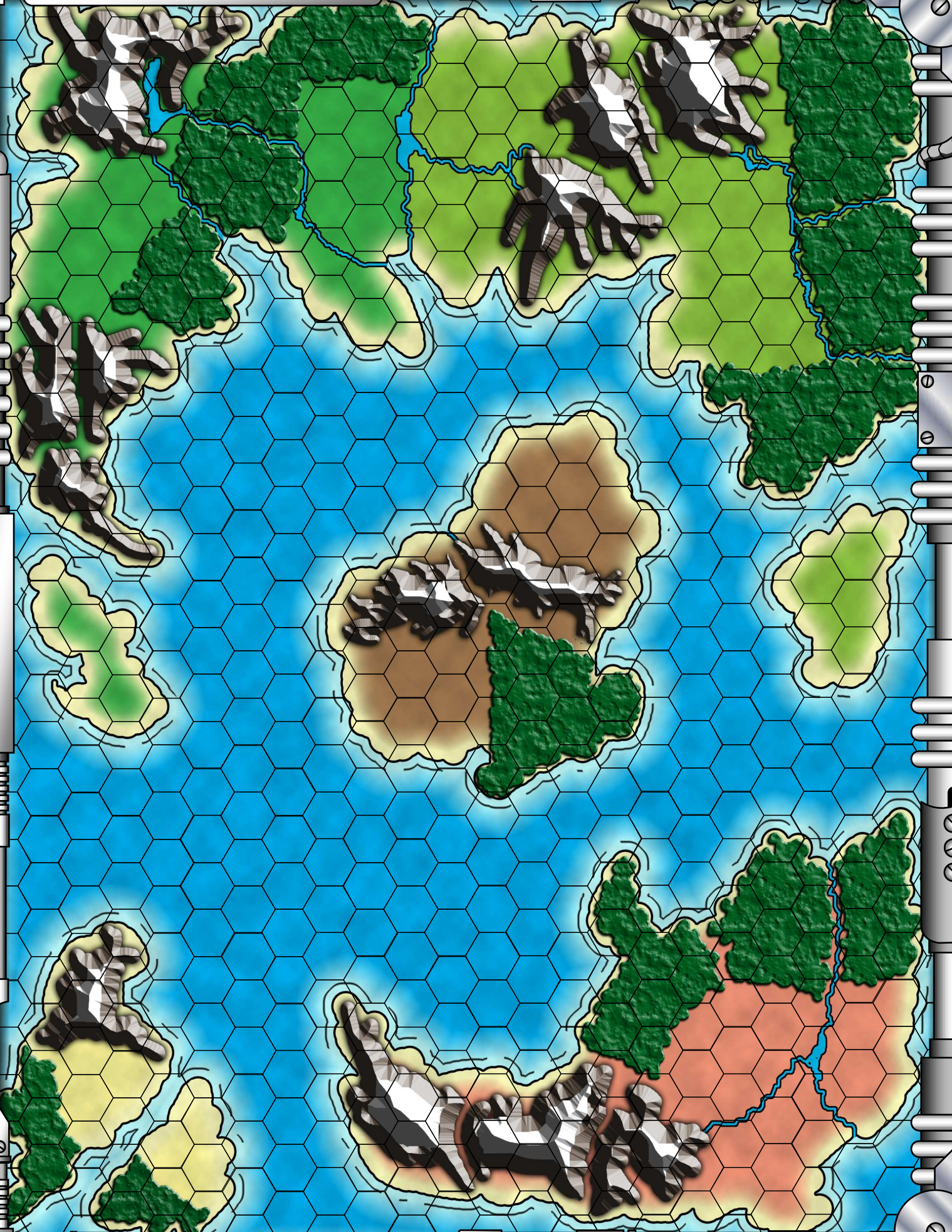

INTERVIEWS

C.J. Williams interviews Steve Winter

INTERVIEW WITH STEVE WINTER

By C.J. Williams

I recently had the pleasure of being able to ask Steve Winter some questions about the origins of Star Frontiers when I stumbled into a conversation with him on the Gleemax boards. Steve Winter was the editor on the original Star Frontiers 1982, Alpha Dawn 1983, Knight Hawks 1983, and Zebulon's Guide 1985. Since I recently had some discussions about Zebulon's Guide, I also wanted to get some confirmations on my observations regarding the book and got some great feedback.

Steve currently works for Wizards of the Coast (WOTC) and goes by the name WOTC_Huscarl in the forums at the WOTC website. On his blog page at Gleemax.com Steve says of himself:

"I went to work at TSR in 1981 as an editor, after a stint as a newspaper reporter. Those were great days, fueled by D&D, beer, The Clash, and the most amazing, creative, and eccentric group of co-workers you could herd together. For 16 golden years I got to edit, design, develop, write, playtest, manage, revise, market, and direct the greatest RPG ever [AD&D]."

"TSR and I parted ways in '97 when the company moved to Seattle. Despite a very attractive offer, I stayed in Wisconsin for a host of reasons. For the next four years, I worked on various personal and professional projects, most of which were fulfilling."

"As we always said at TSR, though -- "You'll be back." In 2001, I wound up in Seattle anyway. Before long, I was once again hobnobbing with my fellow wizards and producing the Avalon Hill and D&D Miniatures website."

Now to the questions.

C.J.: Steve Winter was the editor [of everything Star Frontiers], so he can tell you about what went on with why there were so many gaps at the time. Those gaps left a lot up to the Referee . . . "Wonkie" is the word often applied to the Star Frontiers system.

Steve: The original game, called Alien Worlds, was designed by Lawrence Schick and Zeb Cook. It was a more complex, hard-SF focused game. At the last moment, an executive decision was made to vastly simplify the game for a more introductory market. I can't really argue with that decision, but the timing was awful.

The game was then redesigned, not by committee, but by half-a-dozen designers all working essentially independently because of the unbelievably short time allotted. Then it fell to Troy Denning and I to try to develop all those disparate pieces into some sort of coherent whole, with even less time than the designers had (much of it the same time, meaning we were frequently editing chapters that weren't even completely written yet). I don't think I've ever again worked such long hours or experienced that level of stress.

C.J.: All the same, it's a fun game. A tradition of rules flexibility has grown up around the game. You just tailor it to your taste. It's the originality of the story line, the races, and the retro feel to the game that people have always liked, and today you can clearly see it has that early 80's naivety to it.

Steve: Yeah, considering its birthing pains, it turned out reasonably close to what we envisioned. It just didn't work as smoothly or elegantly as might have been hoped.

C.J.: "Huscarl"? Where did you come up with that one (please don't say it's your grandfather, then I'll feel bad)?

Steve: Huscarl is an old Norse term that describes a household soldier -- a warrior of a lord's personal retinue or bodyguard (hus + carl, literally "house man"). Besides which, my dad's name is Carl (not my grandfather -- close), and I always thought it was a cool-sounding name.

C.J.: You also co-edited on Zebulon's Guide. Can you explain the story on Zeb's? As far as I can tell, it was meant solely as a supplement (thus "Accessory"), and was not meant to replace or update the game, but seems to have been meant to provide an alternate resolution mechanic with the Column Shift mechanic to help bring in those familiar with the mechanic in other games. It seems TSR was just trying to stay with the trend. Unfortunately, Zeb's seems to have gone over like a lead balloon.

Steve: When Zebulon's Guide came out, column-shift mechanics were all the rage in RPGs, as you noted. And for good reason. It's a more robust system than straight adds and subtractions from percentage scores. For example, a 20-point penalty is huge when your chance to succeed is only 30% to begin with but much less severe when your chance was originally 75%. The column shift table treats those situations (which are everywhere in a %-based game such as Star Frontiers)

more equitably, statistically speaking. They're not as quick or intuitive, unfortunately, because everyone needs the table in front of them.

C.J.: At a time when games were seeking to produce high quality presentations, the presentation of Zeb's leaves a lot to be desired. Can you explain anything regarding that? If anything looks tossed together, it's Zeb's.

Steve: Zeb's Guide, IIRC, was meant to be the swan's song of SF. That is, there would be no more SF products after Zeb's (or, after the Zeb three-book series was complete, which never happened). Most of its shortcomings can be attributed to that. It was a red-headed stepchild, left to its own devices while most of the department resources were funneled into 'more important' products.

C.J.: Whose brainchild were the Ifshnit, Osakar, and Humma? Were they all Kimber Eastland's creations? By the way, I do like the treatment of the Mechanon as opposed to Starspawn of Voltturnus's treatment, but I hate the images for all the races in Zeb's, especially as they didn't do justice to the descriptions.

Steve: Pretty much everything in the book came from Kim Eastland, with Harold Johnson and myself making some contributions. I couldn't say at this point precisely who did what. If I had the book in front of me, it might jog my memory. Essentially, though, I'd say it was 80% or more Kim's work.

C.J.: In Zeb's, Mentalist appears to be very well thought out as far as providing drawbacks to reign in the powers from becoming rampant. Can you say how much play-testing went into the Mentalist mechanic?

Steve: I know that Kim had a gaming group in Moline, Iowa, where he still lives, and that they played SF regularly. They playtested most of what's in the book. It got only cursory playing at TSR, for the reasons noted above.

...One more amusing story about Zeb's Guide --

In 1985, both D&D and Marvel Super Heroes were big guns in the market. Kim told me that, while he was working on the ZG manuscript, he had a dream that the cover of the book showed a hulking barbarian with two beautiful women at his feet and Spider-Man, but no SF elements. So when the book was nearing the end of its production cycle, I took a shot of the cover frame and dropped in a sketch by Larry Elmore of Snarf with Althea at his feet, then plopped in Spidey swinging through the picture on a web, and sent it to Kim as the cover proof. I wish I still had a copy of it, but I'm sure it's long gone.

C.J.: Thanks! I appreciate your taking the time to answer my questions, Steve.

I will attempt to bring further interviews in the future when I can track down certain individuals. In the

meantime, good gaming to you and keep checking in for more great content from the Star Frontiersman.

Postscript: Well, after I thought we were done with the interview, Steve was inspired to blog on Gleemax about our discussion entitled "Zebulon's Guide to Lunacy". Here's what he wrote:

"A recent discussion about Star Frontiers over in the General Gaming forum got me thinking about this game again. It was very popular in its day, outselling all other SF RPGs, including the venerable Traveller (or so we were told; I never saw specific sales figures). I was intimately involved in the creation of that game, as noted in the forum.

"Because of the ... let's say "hectic" ... manner in which Star Frontiers came to be, I've always harbored rather negative feelings about it. For something like six weeks, it was the only thing in my life. I was at my desk at 7 in the a.m.; worked until ~8 or 9 p.m.; went to a tavern for dinner and a beer, frequently staying until they threw me out; then back at my desk again at 7 the next morning. All the while, I occupied the middle of a whirling storm of designers who were each working on a separate piece of the game and generally so stressed and ticked off that they barely spoke to one another except through me. Repeat without variation for six weeks. Oh, and I also missed the chance to go to Gencon East with the rest of the R&D department because I was up to my a&& in space alligators. While everyone else was hooting it up at a game convention, I remained chained to an oar.

"Is it any wonder that I didn't care much for Star Frontiers?"

"And yet, the game was immensely popular and still has a devoted following 20+ years later. I guess it's time I come home and embrace the child.

"The discussion about Zebulon's Guide in the forum got me thinking about the joke cover that I put together for Kim Eastland ... I assumed that this was lost in the miasma of time. Last night, however, out of curiosity, I reopened my file folder of 'things that used to hang on my wall at TSR' for the first time in many years. Sure enough, in that hoary collection of comics, newspaper clippings, Erol Otus doodles, and beat doggerel, was the Snarf/Spider-Man Zebulon's Guide cover. So I present it here, for its first public viewing since 1985. Revel in its august light.

"Steve"



INSPIRATION ZONE

By Various Artists

Editor's Note: Trolling around the 'net I find a lot of gaming resources. I don't know the author or source of most of these, they've just been either emailed to me or found by googling. Some have artist signatures, some don't. If you recognize any of these, let me know so I can give proper credit (I think I recognize some of the images from Cyberpunk?) I hope some of these images provide inspiration for your games. If you're an artist and want to do an Inspiration Zone page spread, just submit!

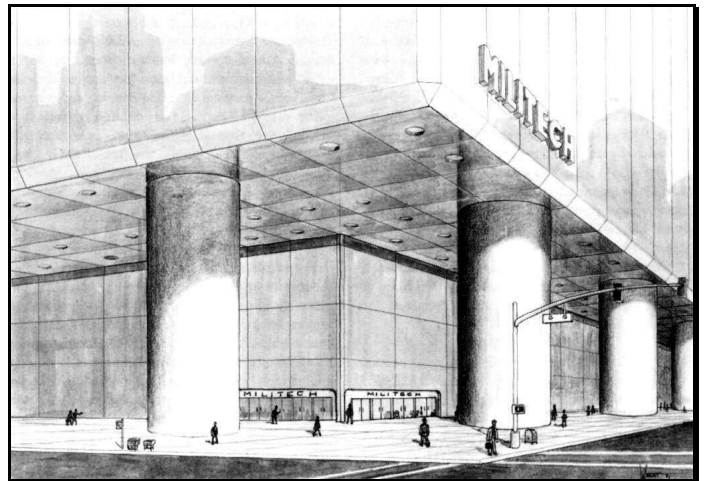
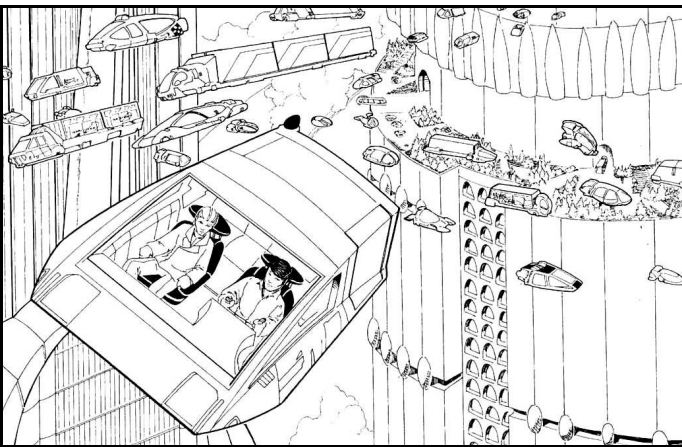
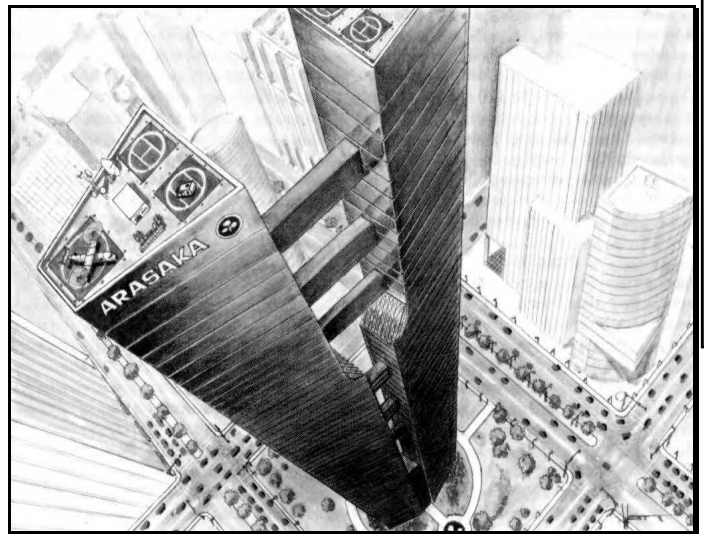
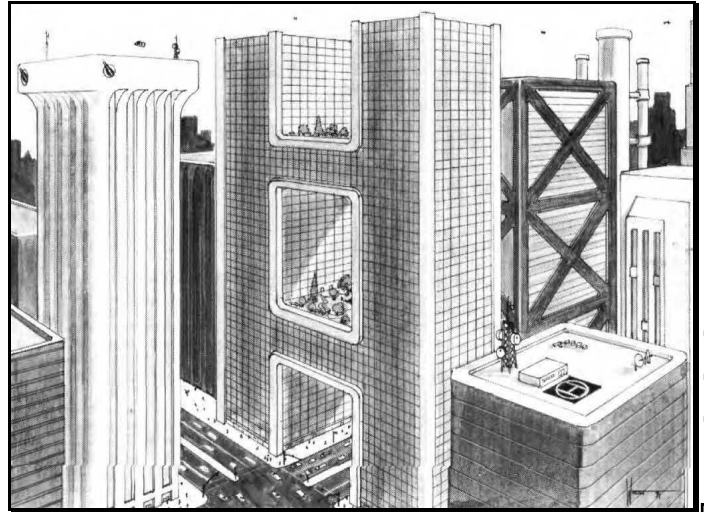
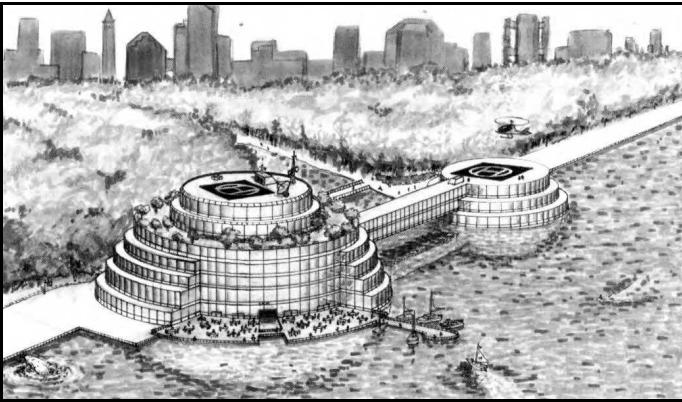

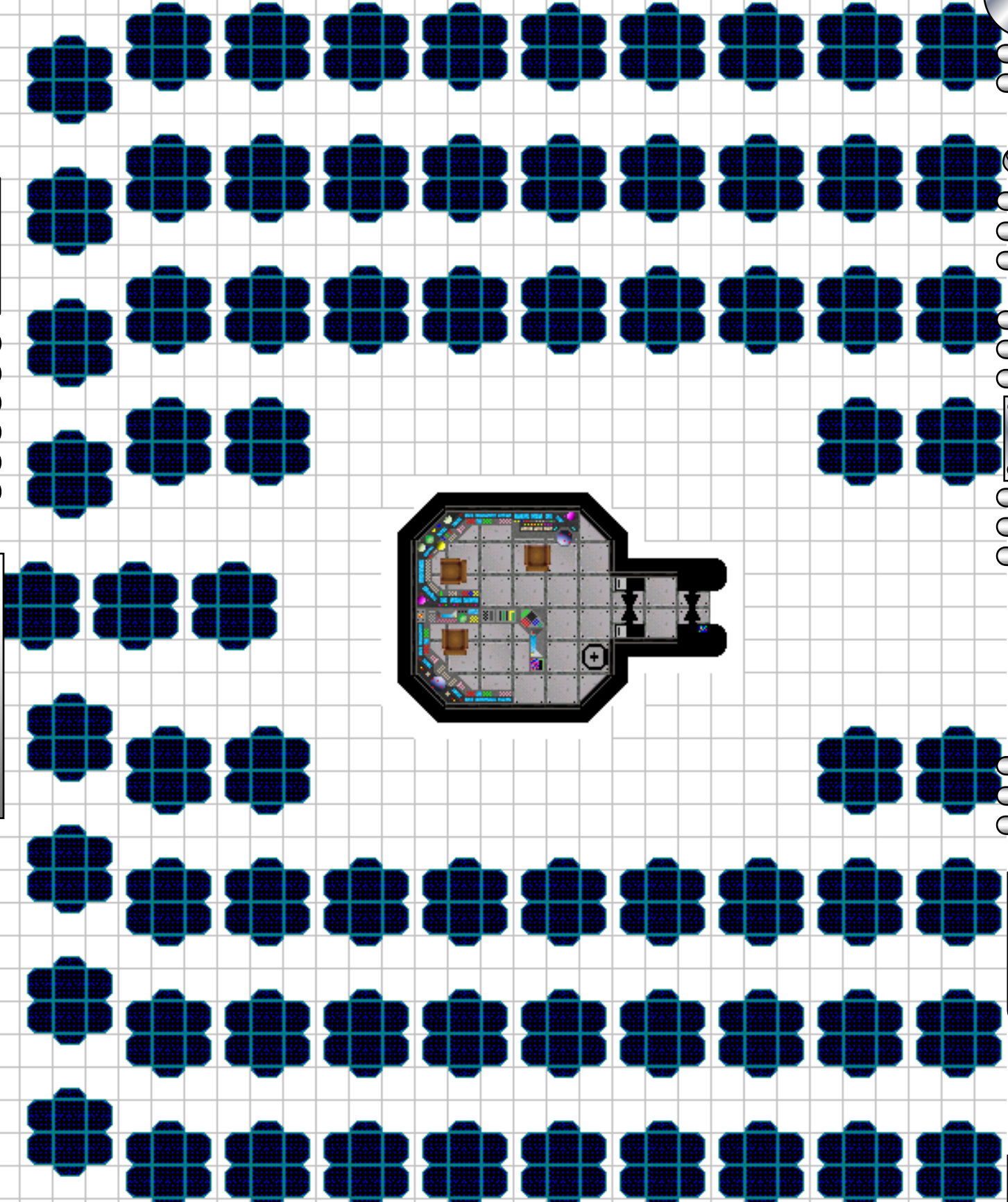

SOLAR POWER CENTRAL

A high-tech power control center sits amid a field of solar collector/generators, providing power to the base the characters must infiltrate. Will they find technicians inside with little more than pocket protectors... or armed guards and a mine-field? That's up to you! This map is a plug-n-play prop for Referees.

-- submitted by Adam Brown.



INTER-GALACTIC WIRELESS

"from the galactic core to the outer rim, we know news!"

124 DIE IN FREAK MONORAIL COLLISION

By THRIK RITH,
The Frontier Tribune



NEW KHIR/EXIB/YAST/ATHOR

From the Bran'shik Diner where she works, Thellum Snirk could see the lights flashing at the rail crossing on the other side of T'nik'ee Thoroughfare. She heard the warning sirens and watched the safety Bars raise from their subterranean turrets.

And she saw the red skimmer risk it.

As the high-speed, southbound Meteor-Class Monorail bore down, the skimmer, carrying three Yazarian youth, headed east on Fin'ker Avenue over the first and second of the three sets of tracks within the crossing. It didn't make the third.

'The monorail had no chance to stop,' Snirk said.

The impact was horrific. It threw the skimmer into the air, as high as the top of nearby light poles, Snirk and another witness said. The skimmer came to rest 450 meters west of the crossing, unrecognizable. Its engine and other parts came loose, leaving a trail of debris.

'It was like a bad nightmare,' Snirk said.

One Yazarian female was thrown from the skimmer, and everyone was killed, hopefully upon impact. The operator in the lead cockpit segment of the monorail then activated the emergency braking system but did not know that a chunk of debris had lodged into the hydraulic system severing several lines and damaging the wheel alignment retaining pins. Two kilometers later the engine segment of the monorail dropped

from the multi-crete suspension rail pulling several trailing cars off the track with it. Within minutes of the 8:44 p.m. collision, a monorail official said there were no survivors in the cars that had left the track, adding 121 to the death toll for a total of 124 casualties. No one was taken to a hospital, Star Law Officer Tandry said. It was several hours after the crash before all the victims and the wreckage were removed.

The New Khir coroner's office said they were unable to verify the identities of the victims due to the extent of the wreckage. Notification of next of kin could take some time, reported the coroner's office press official.

A video of the crash has been recovered from a nearby kaboomite warehouse but will not be released while the investigation remains open, New Khir Enforcer spokesman Thryfe Rant said.

Rant confirmed that the warning strobe lights and safety bars were operating correctly at the time of the crash. If a malfunction of the crossing safety system proved to be the case, DanMar, the Transit Authority Maintenance Chief, had said earlier, the driver of the skimmer would not be at fault. 'Parents allowing their children to mess around with the hover settings of a skimmer is the real crime in my book! It's a useless, senseless tragedy that could have been prevented.'

While authorities struggled to piece together identities, many people on-site said they knew some or all of the presumed victims, who were said to have ties to the

industrial neighborhood surrounding the crossing.

Meteor-Class monorails are licensed to travel up to 250 KPH on this stretch, said Puller, the Monorail spokeswoman.

The UPF Monorail Safety Administration said New Khir ranked 7th among cities in the Athor system for most deaths at high-speed monorail crossings.

Researcher Schatowe Dozer contributed to this report. Reporter Thrik Rith can be reached at Transponder 183710397294 on the deep space relay.

WASTE HAULERS WANT ORDINANCE CHANGE TRASHED

By HANNET SHYQS,
Pan Galactic Gazette



PORT LOREN/GRAN QUIVERA/PRENGLER

What is county ordinance 569996.2012-34, and why are you hearing so much about it?

A small band of protesters converging outside the city ministry building, are bringing the once-obscure trash-hauling ordinance into

Super
Sale



© Sherry Nelson



www.TheFadingLight.com

THE FADING LIGHT

Yazarian Space Art, LLC

Whether you are decorating for your domicile or adding those last finishing touches to your space craft's living spaces, by adding Y.S.A. original artwork you will be impressing guests, passengers, and crew. Do not settle for discount chain-store reprints, settle for nothing less than total and uncompromising quality. **Art & Statuary.**



INTER-GALACTIC WIRELESS

"from the galactic core to the outer rim, we know news!"

public spotlight.

The woman responsible for much of the attention is Ysantia, a small-businesswoman who owns a small robot repair service and occasionally hauls construction debris to support her 32 hatchlings.

Here's why some trash haulers are upset: city ordinance 569996.2012-34 governs trash collection in unincorporated suburbs.

A proposed amendment would give the nearest suburban city greater authority to enforce restrictions on certain waste haulers permits - a move they say will put the small guys out of business.

The original settling of the Capellan Free Merchants (CFM) signed a trash agreement that granted exclusive rights to three companies, Waste Management, Republic Services and Waste Services Inc., to collect commercial trash and debris in exchange for low residential pickup rates and reduced import taxation of trash removal heavy equipment.

The provision was included in a new contract signed with the three franchise haulers last year.

Regional attorneys drafted a stricter ordinance after a lawsuit challenged the provision and a judge sided with an independent hauler that the ordinance didn't cover residential construction waste.

The Citizens Way rights advocacy collective plans to appeal that ruling.

Reporter Hannet Shyqs can be reached at Transponder 432510767288 on the deep space relay.

WEEDING OUT UNDOCUMENTED WORKERS

By NORC WHOT, Zebulon Free Press



A frequent question in the UPF immigration debate is why the individual star systems aren't enforcing existing system-wide transportation laws and deporting the 12 billion illegal workers that have slipped through the documentation gateways.

The fact is that immigration and transportation agents are trying and appear to have their priorities straight. They're working hardest in areas where a saboteur, terrorist or blackmailed immigrant could do the most damage. They're also targeting immigrants guilty of crimes greater than unauthorized entry.

UPF secret agents have collared only 512,100 undocumented immigrants who sneaked back onto their home planets after being deported. Those undocumented illegals still at large are feared to be child molesters, slavers, smugglers, gang members, violent criminals, or Sathar agents.

In recent years they've caught undocumented workers in spaceports, military bases, power plants and all manner of sensitive facilities.

Employers usually aren't to blame for the security breach (a controversial subject inflamed by the Dralasite religious community). Many illegal immigrants get work by presenting phony documents, government officials told Zebulon Free Press. Catching them isn't easy.

In the past four years, the UPF Department of Spacefaring Security has audited the payrolls of some 9,000,000,000 companies with access to vital infrastructure - employees who work on transportation structures, in refineries, in fission power plants and even at military bases. They discovered that 30 percent have unknowingly hired illegal workers.

The Frontier needs tighter enforcement of its space-lanes and identity cards that are harder to forge.

Reporter Norc Whot is on undercover assignment and cannot be reached.

TRIPLE BOMBING DEEPENS TERLEDROM TENSIONS

By SIF NIG, Star Law Times



ARCH CITY/ TERLEDROM/FROMELTAR

ARCH CITY, Terledrom - Three bombs killed at least 176 Vrusk and Dralasites Monday in the trade-rich southern city of Kirkuku, city police said. It was the city's worst attack in recent memory.

Ethnic tensions have been building in Kirkuku, with its mixed population of Vrusk, Dralasite, and Humans, as it approaches a referendum on its future legal expansion into the rim.

Armageddon Spacesuits, Inc.

Don't EVA without one!

THE FADING LIGHT



Now 88% More Radiation Resistant!!

Armageddon Spacesuits, Inc. Our EVA suits are recognized as the leader in discount environmental exposure suits. Active & Retired Star Law personnel receive special discount pricing. Restrictions apply, see dealer for details. Money-Back Guarantee if our suit's failure results in death.

www.TheFadingLight.com

NOVEMBER 2007



INTER-GALACTIC WIRELESS

"from the galactic core to the outer rim, we know news!"

Loru Trova, a senior member of the trade council, said the bombings came at a time when militants are being chased by UPF forces in a series of offensives around the capitol city.

Chancellor Edcar held a lengthy videoconference call with Fromeltar leaders, including Prime Minister Nauri Malaki, in which he urged them to make progress toward reconciliation.

Also, the UPF military announced an offensive southwest of Arch City that is intended to prevent militants and smuggled weapons from entering inner city where the tension is the highest.

The military is weighing new directions for Terledrom, including an even bigger troop buildup if Edcar thinks his 'surge' strategy needs a further boost, the chairman of the Joint Chiefs of Staff said.

UPF Master General Pi'nk Emon revealed that he and the other war chiefs are developing their own assessment of the situation independently from all political governing bodies. Pi'nk said another option under consideration is maintaining current troop levels beyond the new year.

In Gran Quivera on Monday, Trade Relations Coordinator Harny Reider of Groth said he would force the chamber's first all-night debate on the Terledrom war tonight before a full vote Wednesday on whether to bring home all combat troops by before the possible outbreak of a system wide war.

Officials are using Frontier rules to insist the measure have 402,604 votes to pass - a de facto filibuster because it takes that many votes to cut off debate.

Star Law acting Secretary General Ban'Ki Mook on Monday warned that an abrupt UPF troop pullout could further deepen the crisis at Terledrom.

Although Ban'Ki expressed reluctance to jump into the debate, he emphasized that the rest of the Frontier has a stake in the outcome of this conflict.

'Great caution should be taken for the sake of the Terledrom people,' Ban'Ki said when asked the possible pullout. 'Any abrupt withdrawal or decision may lead to a further deterioration of the situation.'

Ban'Ki is scheduled to meet with Edcar today.

Information from The Associated Press was used in this report.

Reporter Sif Nig can be reached at Transponder 436711290002 on the deep space relay.

RYKER'S RAMMERS CLAIM GRAV-BALL TITLE

By TILLER YAPS,
Frontier Wide Sports Telecom



After two heart-stopping days of final competition, several acid rain delays, 122 hours of raw sanctioned tournament level competition and 1,392 games, the championship of the Sling and Shoot Grav-Ball tournament championship began at 6 p.m. on an intramural space station field at the University of Zebulon: Ryker's Rammers vs. current title holders, Neekucs Flimphlams.

When the siren blew the final regulation 430 minutes final game ensued, Ryker's Rammers cheered and hoisted the title trophy, winners by a 15-6 score.

As the Flimphlams took a knee at midfield in respect for the new titleholders, the Rammer's coach Q'Klim gave his squad a little perspective, and hopefully, he added, a lot of future incentive.

'The last time we won the Sling and Shoot was eleven years ago.' Q'Klim said. 'The point is we proved this weekend beating 435 other teams that we have a good grav-ball team and we have proven that we are not the flukes reported by our critics.'

Q'Klim said the weekend's best win came in the semifinal against one of the tourney's most surprising and inspired

teams, Braziir, which lost to the Flimphlams 18-15 after leading 15-0.

'We took our lumps last year but I'd say we've made some improvement,' said Flimphlam's coach Jima Porq'm, who struggled at the same tournament last summer. 'These guys have been working hard in the off-season and I think that hard work showed this weekend.'

'Quarterback Aammurr played great. The good thing is that I think he got better after playing in the lesser leagues before turning pro.' Said Q'Klim.

In the final for Ryker's Rammers, the key players included hoverback Zeek Grossi, who connected fourteen slamdowns with Dar Youn and Anony Iams on plays of 50 and 60 yards, respectively. The championship was sealed with less than 5 minutes left when Kyrle Hollowman snagged an interception on a cross check slant pattern.

Reporter Tiller Yaps can be reached at Transponder 73518354223 Extension C-Band 411 on the deep space relay.

Author's Note:

DISCLAIMER: All or part of media presented here is for entertainment purposes only and has been obtained by public accessible means via the internet. In some cases the material has been based upon real-life works but was heavily modified in order to present it here as spoof entertainment. All rights to the material remain the property of the original copyright holder.

-- John Mark Simpson
www.TheFadingLight.com

Graphic Artists/Illustrators

"The Fading Light" eZine is the official publication of Sci-Fi Author, John Mark Simpson. TFL was created as a place for aspiring science fiction writers and artists to showcase their best works. Sometimes you just want to be seen...

Items Needed for the eZine:

- Cartoons
- Illustrations
- Story Starter Art
- Graphics

Show Us Your Best Science Fiction Art & We'll show it to the World!

www.TheFadingLight.com

UPF FIGHTERS

By Shadow Shack

F-40C VULCAN

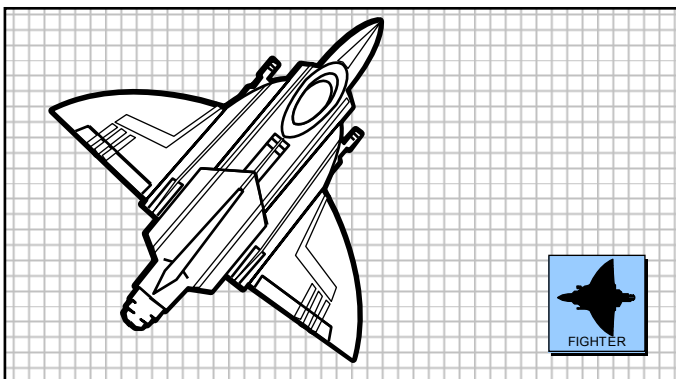

This is an updated version of the standard UPF Fighter from the Star Frontiers Knight Hawks game to take advantage of the more versatile options of the Pod Laser. Price: 886,600Cr.

F-40 VULCAN

HS 1 **HP** 8 **Powerplant:**
Single sub-atomic A

ADF 5 **MR** 5 **DCR** 30 **Crew** 1-2

Armament:

Assault Rocket (x3) or
Pod Laser (Long Range) or
Pod Laser+Assault Rocket (x1)

Defenses:

Reflective Hull

Communication/Detection Equipment:

Subspace Radio, Radar, Videocom, Auto-Eject Module, Streamlined

Computer: (LVL: 3, FP: 68, SP: 20)

Alarm (1), Analysis (2), Assault Rocket (1), Astrogation (2), Auto Eject (2), Computer Lockout (4), Damage Control (1), Drive (4), Information Storage (1), Life Support (1), Maintenance (1)

Description: Upon graduation from Gollwin Academy, pilots may see service with an updated version of the F-40. The F-40C convertible fighter that can switch weapon systems according to the mission between a long range pod laser system, a trio of assault rockets, or a standard pod laser and single assault rocket; along with the software to run these various system configurations.

A twin hull version has also been in limited production, the F-40C2 designation. Some militias utilize the twin fuselage craft for long range patrols, where pilot crews may switch shifts operating and sleeping.

UPF-5 SHADOW STAR

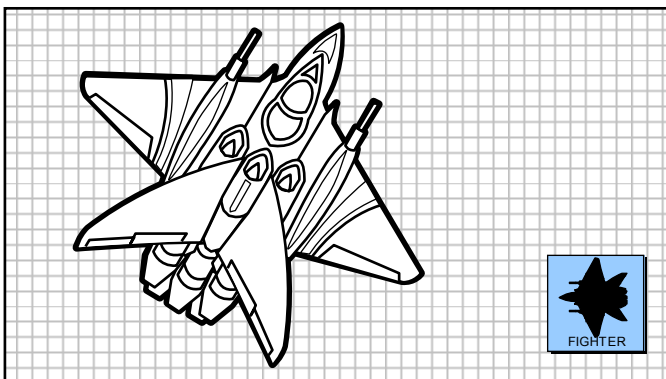

Vintage star fighter.

UPF-5 SHADOW STAR

HS 1 **HP** 8 **Powerplant:**
5 Chemical A

ADF 5 **MR** 5 **DCR** 25 **Crew** 1-2

Armament:

Pod Laser (Long Range)

Defenses:

Reflective Hull

Communication/Detection Equipment:

Subspace Radio, Radar, Videocom, Auto-Eject Module, Streamlined

Computer: (LVL: 3, FP: 68, SP: 20)

Alarm (5), Analysis (2), Astrogation (2), Auto Eject (2), Computer Lockout (4), Damage Control (5), Drive (1), Information Storage (1), Laser Cannon (1), Maintenance (5)

Description: The PF-5 Shadow Star is a relic of a design, dating back to before the first Sathar War. It was the Frontier's earliest star fighters and the first from Pan Galactic, who still produces the craft today albeit through special order. The design is simple yet effective, and has been retrofitted over the decades to keep up with modern fighter technology. The original assault rocket system was replaced by a long range pod laser system for civilian use, although military contractors may order them with the three rocket system instead. Life support is also not included but available as an option. It still boasts the original yet updated design on all five of its chemical drives, making it very affordable for purchase and regular use. Very few militias or government subsidies incorporate the PF-5, for the most part it will be in the service of private operations such as civilian businesses and occasionally used by pirates as well.

RF-41 SEEKER
(AND S/RF-41 SURVEILLANCE CRAFT)

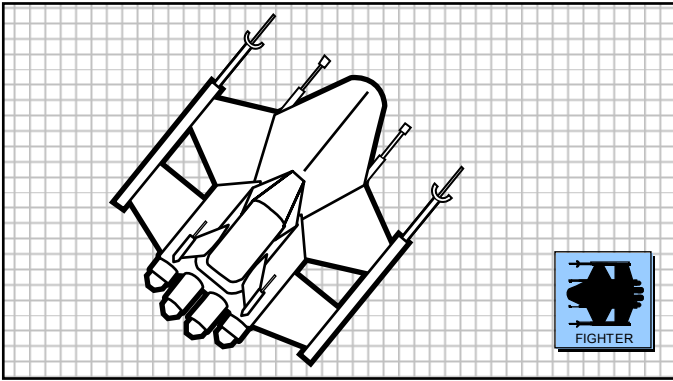

Reconnaissance fighter

I-76 ENFORCER

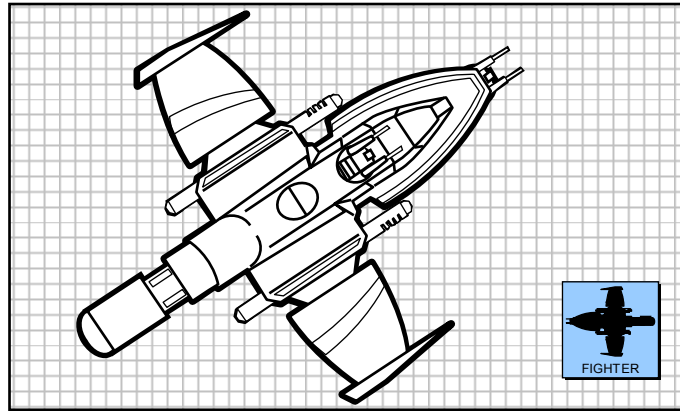

Heavy fighter

RF-41 SEEKER

HS 1 **HP** 8 **Powerplant:**
Four Ion A drive

ADF 5 **MR** 5 **DCR** 30 **Crew** 1-2

Armament:

Pod Laser+Ion Cannon

Defenses:

Reflective Hull, optional Deflector Screen (5hp)

Communication/Detection Equipment:

Subspace Radio, Radar, Videocom, AEM, Streamlined (S model includes 1/2 camera system, energy sensor, and sensor jamming equipment)

Computer:

Alarm (4), Analysis (4), Astrogation (4), Auto Eject (2), Computer Lockout (6), Damage Control (4), Drive (3), Information Storage (2), Laser Cannon (1) x2, Life Support (1), Maintenance (4)

I-76 ENFORCER

HS 2 **HP** 16 **Powerplant:**
Shielded inboard/
outboard atomic A drive

ADF 3 **MR** 4 **DCR** 45 **Crew** 2*

Armament:

Pod Laser, Assault Rockets (x2), Ion Battery

Defenses:

Reflective Hull, Deflector Screen (6hp)

Communication/Detection Equipment:

Subspace Radio, Radar, Videocom, AEM, Streamlined

Computer:

Alarm (1), Analysis (4), Assault Rocket (1), Astrogation (4), Auto Eject (2), Computer Lockout (4), Damage Control (1), Drive (4), Information Storage (1), Laser Battery (1), Laser Cannon (1), Life Support (1), Maintenance (1), Robot Management (LVL corresponds w/ robot)

* Plus Maintenance Robot

Description: The original F-41 design was a lower budget competitor to WarTech's sibling I-76 heavy fighter, but it failed to match the Enforcer's payload and versatility. Hence it became converted over to a Reconnaissance Fighter with optional sensor packages, and filled this role very well.

Ion Cannons allow the craft to capture fleeing vessels as well, preserving their crew and cargo for questioning and observance afterwards. The Pod Laser system also allows for more permanent damage to be inflicted. The ship allows for two crew members but can be operated by a single pilot for most non-recon or in-system duties.

Unlike most fighters, the craft is interstellar capable.

Description: WarTech's sibling micro-corporation "Sovereign Virtue" belted out this fantastic heavy duty multi-purpose fighter many decades ago. It's an older design that has been upgraded over the years following WarTech's funding of the company, and has slowly become known as the "workhorse of the Frontier" by fighter pilots. The Enforcer's shielded atomic drive does not have a governor installed, so it is interstellar capable. To this end an aft storage bay is outfitted to accommodate an MR-series maintenance robot to assist with overhauling the atomic drive. The vessel's lacking performance is made up by an ability to take a severe beating by fighter standards, the rocket payload along with two different beam weapon systems (a forward firing pod laser and an Ion Gun Turret) makes it a versatile craft well suited for many roles. The new Deflector Screen defense system is a recent upgrade, the I-76 was the first fighter craft to be equipped with it and as a result it can sustain even greater amounts of punishment.

A variant exists without airfoils, restricting it from atmospheric use. The I-76S variant is typically utilized by private organizations or carried aboard larger vessels for defensive duty. Aside from a slightly lower price tag, there is no difference between the two craft save for the atmosphere capable airfoils.

SF-1 DAGGER

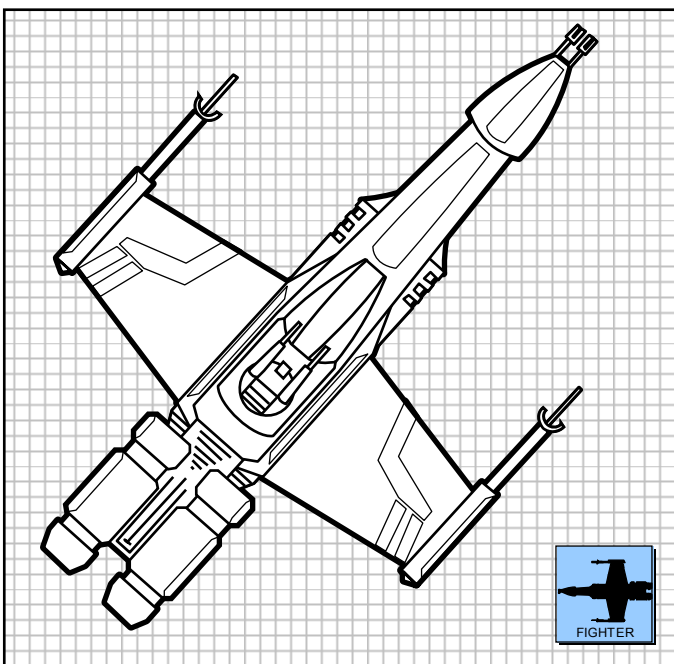

Advanced tactical fighter

SF-1 DAGGER

HS 2 **HP** 12 **Powerplant:**
Four Atomic A

ADF 5 **MR** 5 **DCR** 30 **Crew** 1-2

Armament:

Pod Laser, Ion Cannon, Assault Rockets (x2),
Pod Laser Turret

Defenses:

Reflective Hull, Deflector Screen (6hp)

Communication/Detection Equipment:

SubSpace Radio, Radar, VideoCom, Deluxe
Astrogation, AEM

Computer:

Alarm (4), Analysis (6), Assault Rocket (1),
Astrogation (4), Computer Lockout (6), Deflector
Screen (2), Damage Control (4), Drive (4),
Information Storage (1), Instalation Security (4),
Laser Cannon (1) x2, Laser Battery (1), Life
Support - capacity:2 (1), Maintenance (4), Robot
Management (LVL corresponds w/ robot)

Description: The Dagger is WarTech's latest top secret creation which is scheduled for released to active duty in f.y. 72. Little is known about the new high tech Tactical Fighter, aside from a few spy holophotos from test flights, but it promises to be a heavily armed and high performance interstellar-capable fighter craft. It also promises to boast a high price tag...but WarTech feels the craft will be worth every credit. Only Rayax Transport's prototype Knight Hawk poses a threat to the future contract for the next generation heavy fighter, but WarTech feels the higher price tag of the Hawk will quickly sink the Dagger's blade into the contract.

F-20 ARROW*

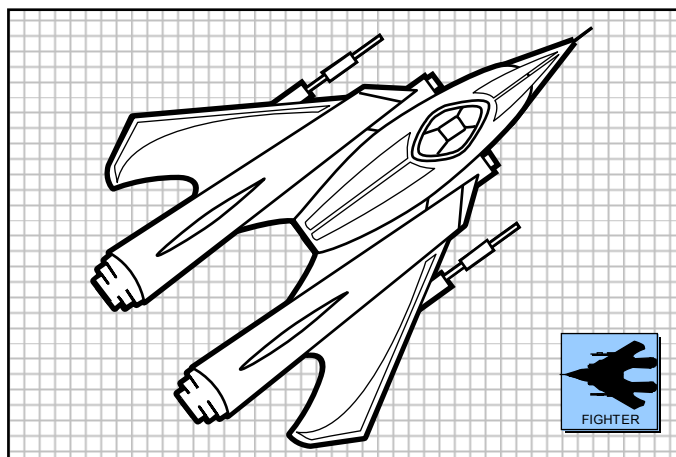

Tactical light fighter

F-20 ARROW

HS 1 **HP** 7 **Powerplant:**
Two Sub-Atomic A

ADF 6 **MR** 5 **DCR** 30 **Crew** 1

Armament:

Pod Laser, Assault Rockets (x2)

Defenses:

Reflective Hull

Communication/Detection Equipment:

Unreleased. Almost assuredly includes:
SubSpace Radio, Radar, VideoCom, Deluxe
Astrogation, AEM.

Computer:

Unreleased. Unconfirmed reports claim its
computer is at least as capable as the SF-1
Dagger: Alarm (4), Analysis (6), Assault Rocket
(1), Astrogation (4), Computer Lockout (6),
Deflector Screen (2), Damage Control (4), Drive
(4), Information Storage (1), Instalation Security
(4), Laser Cannon (1) x2, Laser Battery (1), Life
Support - capacity:2 (1), Maintenance (4)

Description: WarTech's latest entry in the light fighter arena will be the Arrow, a well armed and snappy accelerator. Rumors lead to a possible Deflector Screen system as well, assuming it can be added without infringement on the performance. WarTech expects the Arrow to replace the F-40C by f.y. 76

*Original design appears in the ShatterZone game, all rights reserved

Editor's Notes: These illustrations are derived directly from the author's own artwork. His were made for viewing on the web, so their resolution is low for optimal bandwidth. Since this magazine is for print, I had to re-illustrate them for the higher resolution we have to work with. Also note that there are several new pieces of equipment mentioned in these Fighter descriptions, which are defined at the end of this article.

YT-100 "PHOENIX"

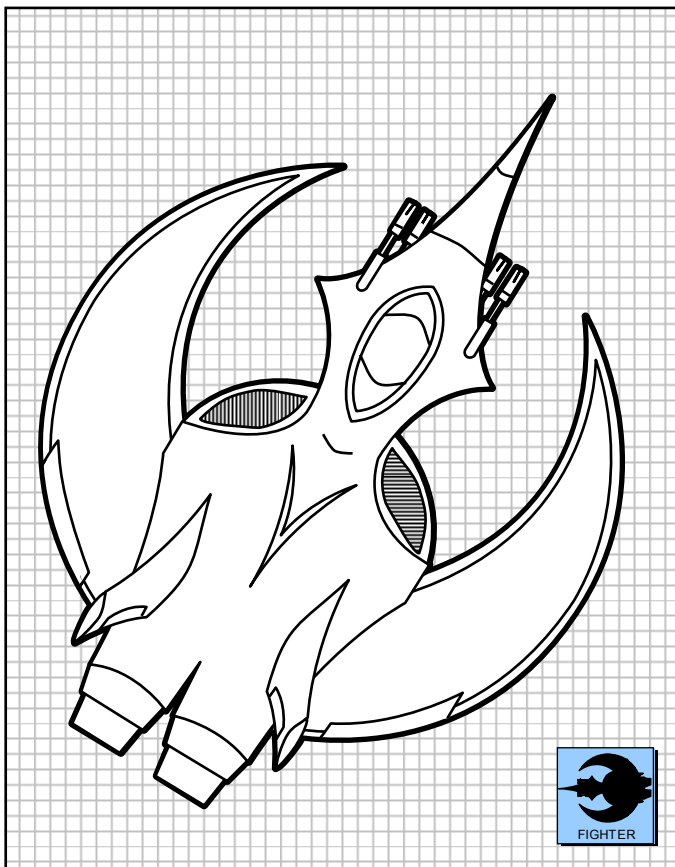

Tactical fighter

A-5 KNIGHT HAWK

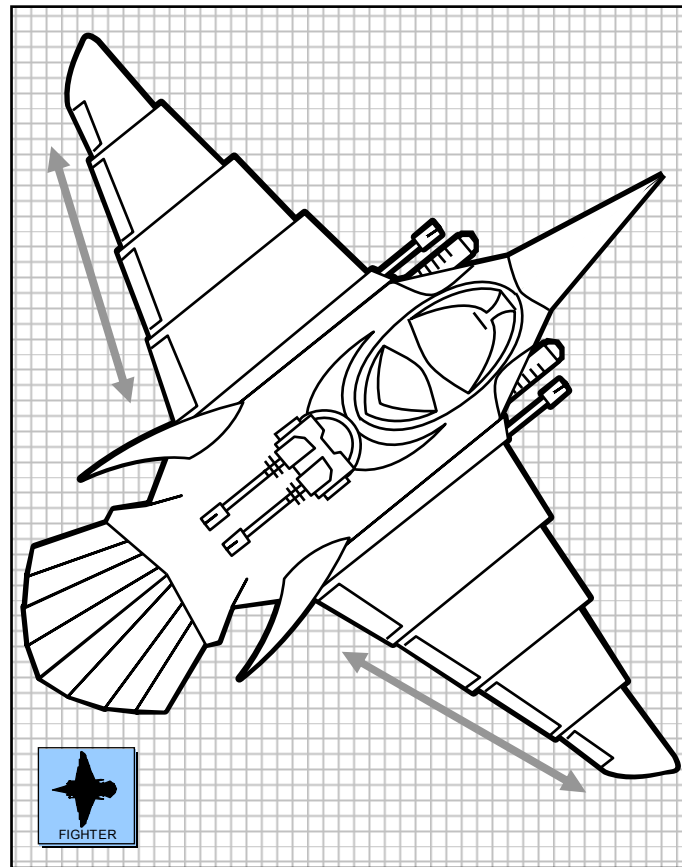

Advanced tactical fighter

YT-100 PHOENIX

HS 1 **HP** 8 **Powerplant:**
Twin SC Ion A
ADF 6 **MR** 5 **DCR** 30 **Crew** 1-2

Armament:

Twin Pod Lasers (Long Range), Linked.

Defenses:

Reflective Hull, Deflector Screen (5hp)

Communication/Detection Equipment:

Unspecified. Sources claim: SubSpace Radio, Radar, VideoCom, Deluxe Astrogation, AEM

Computer:

Unspecified. Probably: Alarm (4), Analysis (6), Assault Rocket (1), Astrogation (4), Computer Lockout (6), Deflector Screen (2), Damage Control (4), Drive (4), Information Storage (1), Instalation Security (4), Laser Cannon (1) x2, Laser Battery (1), Life Support - capacity:2 (1), Maintenance (4)

Description: Rayax Transport is working on two prototype fighter designs, with the Phoenix being a prime candidate to be contracted out to SFC. It has one controversial aspect: a profile that resembles a Sathar Fighter...it remains to be seen if this will be viewed as a drawback or not. RT feels that the craft's nimble and aggressive performance coupled with advanced fire control should quickly overcome any initial thoughts concerning the visual appearance. Expected to see active duty by f.y. 73.

A-5 KNIGHT HAWK

HS 2 **HP** 15 **Powerplant:**
Twin SC-Ion A
ADF 6 **MR** 5 **DCR** 40 **Crew** 1-2

Armament:

Twin Pod Lasers: Linked, Assault Rockets (x2), Pod Laser Turret, Grapple-Claws.

Defenses:

Reflective Hull, Deflector Screen (6hp)

Communication/Detection Equipment:

SubSpace Radio, Radar, VideoCom, Energy Sensor, Deluxe Astrogation, AEM

Computer:

Alarm (2), Analysis (6), Assault Rocket (1), Astrogation (4), Computer Lockout (6), Damage Control (2), Deflector Screen (2), Drive (4), Information Storage (1), Instalation Security (6), Language (3), Laser Cannon (1) x2, Laser Battery (1), Life Support - capacity:2 (1), Maintenance (2), Weapon Link (1)

Description: The basic lines of the Zuraqqor fighters inspired Rayax's heavy fighter design, adding further controversy to their designs. They utilized a slew of their own tweaks to arrive with a prototype for the next generation advanced tactical fighter, designed in accordance to demands laid out by Mercenary Starbase who doesn't seem to mind the 2.5Mcr price tag of each unit. Whether the UPF opts for a contract remains to be seen, but 2.5 mill seems rather steep so it is quite unlikely. RT has managed to keep the lid on this design very tightly, so aside from a holoivid of a test flight little is known about these menacing craft that should be made available by f.y. 75.

NEW STARSHIP TECHNOLOGY

Editor's Notes: The following information is from the campaign notes of Shadow Shack (that's the name we all know him by). His online games and campaign information has been around as long as there has been a Star Frontiers on the 'net. The following is taken directly from his website at <http://starfrontiers.20m.com> where he has a whole host of Star Frontiers goodies.

You can also stop by at <http://starfrontiers.us> and ask him any questions via PM or forum post about these weapons and defenses. They are necessary to use the UPF Fighters provided on the previous pages, and can easily be adapted for use in your own games.

From my point of view, 'Shack does a fantastic job of developing new technology that is well balanced and can easily be inserted into anyone's game. This is just a small sampling of the stuff he's made over the years.

ION DRIVES

Everything I read about Ion Engines in the rules say that they're powerful, yet their performance as indicated by the rules says otherwise, same ADF as a Chemical Drive. Theoretically speaking, since when is a Chemical Drive restricted to in-system only duty? If they accelerate at the same rate as Ion Drives, and since achieving jump velocity (200 hexes/turn according to the opening text on page 3 of the KH Campaign Book: "12 million kph {1% of the speed of light}", go ahead and do the math...) is just a matter of acceleration, given enough fuel for a Chemical drive what real advantage is there in opting for Ion Drives? Hence, Ion Drives in my campaign allow for an ADF of half (rounding up) that of similarly equipped Atomic Drive powered craft. They can also be mounted in the stern or on struts, seeing as they don't emit any radiation like atomic drives would.

PLASMA DRIVE

Plasma Drives replace the original "powerfully slow" Ion Drives. Simply put, they're cheaper interstellar stardrives when compared to Ion or Atomic drives, sport the same ADF:1 performance of the Chemical Drives, yet permit interstellar travel. (once again assuming enough fuel capacity to achieve 12,000,000 kph and back to zero for the Chemical Drives).

DEFLECTOR SCREEN (DS)

A Deflector Screen allows shielding of smaller starships from enemy weaponry. A DS can absorb as many hits equal to the HS+4. Also, the screen can be adjusted for maximum protection, angle the screen fore and any attacks from ahead are nullified, angle it aft and any rear attacks are quelled. However, any attacks that come from the opposite side can cause damage. To this end, the DS can be set at equal fore/aft protection, but won't provide the same protection all around. A DS protects from all energy and projectile weapon attacks. If the attack comes from the angle protected side, the shield will absorb 100% of the damage, if the attack comes from the opposite side the shield will absorb 50% of the damage. A screen set equally fore and aft absorbs 75% of damage from any side. Each hit takes one charge off the screen (maximum

charge is HS+4), and it takes one standard repair round (three combat turns) for one charge to be reinstated, and the craft must be coasting under non-combat maneuvers (meaning ADF:0 or 1). Due to the inability of the DS projectors to extend over a large area, the maximum HS for a DS equipped ship is HS:6. A DS costs (HS x 1500)credits at a Class:I construction center and takes up (HS x 5)cubic meters of space, and takes a LVL:2/FP:8 computer program to operate.

ALBEDO SHIELD (AS)

Player characters can wear an Albedo suit for protection against lasers, starship owners can opt for a reflective hull to protect their craft from laser attacks. Player characters can also purchase and activate an Albedo Screen for the same purpose, and so it is now with starships too. A starship's Albedo Shield absorbs full damage from all laser attacks for as long as the shield is activated, but it can only be activated for a number of combat turns equal to (HS +4). After which time the shield energy is drained and must be recharged, which takes an equal number of combat turns and the shield can not be reactivated until fully charged. Treat as a reflective hull for hit determination. Minimum hull size is HS:5 and the system costs (HS x 2500)credits at a Class: I center, takes up (HS x 8)cubic meters, and requires a LVL:2/FP:6 computer program to operate.

POD LASER (PL)

A Pod Laser is a down-scaled laser cannon for smaller craft such as star fighters. Simply put, the design incorporated removing the guns from a laser battery and down-sizing them to fit in the fuselage of fighter craft. The PL has a range of 50K kilometers, MHS:1, costs 6,000Cr and takes up 20 cubic meters of space. Treat as a laser cannon for hit resolution and damage is 1d10 with no damage table modifiers. A longer range version (90,000km range) is available at 8,000Cr and takes up 25cubic meters, designated PL(LR). Both systems use the same program that a standard laser cannon uses.

POD LASER TURRET (PLT)

With a MHS:3 requirement for a laser battery, it became apparent that both smaller craft as well as larger craft that can't accommodate a LB due to other restrictions could benefit from a 360 degree field of fire weapon. Hence, following in the successful footsteps of the Pod Laser, the Pod Laser Turret came to be. The PLT has a range of 40K kilometers, MHS:1, costs 8,000Cr and requires 20cubic meters of space. Treat as a laser battery to hit with no damage table modifiers and damage is 1d10. The PLT uses the standard Laser Battery program.

HEAVY LASER CANNON (HLC)

Similar to a standard laser cannon but packs a little more punch. Range is 120,000km, MHS=6, damage is (2d10 +4), cost is 20K credits and requires 50cubic meters. No damage table modifiers, and the standard Laser Cannon computer program is required.

HEAVY LASER BATTERY (HLB)

Similar to a standard laser battery but like the Heavy Cannon, it too packs a little more oomph. Range is 100,000km, MHS=5, damage is (1d10 +2), cost is 12,000Cr and the HLB requires 30cubic meters. No damage table modifiers and the standard Laser Battery program is needed for operation.

ION CANNON (IC)

The Ion Cannon is essentially a small scale Disruptor Cannon, but instead of causing damage it is designed to disable various starship systems. Upon successful hits, roll (3d6 -2) to generate random numbers between 1 and 16, and consult the Damage Table. Assign everything between "hull hit: normal damage" and "electrical fire" a number (1-16), any system hit by an Ion Cannon is disabled for (2d10 +5) combat turns. Range is 60,000km, MHS=1, cost is 15,000Cr and 20 cubic meters of space is allocated for an Ion Cannon. Uses the Laser Cannon program.

ION BATTERY (IB)

Same as an Ion Cannon but with a 360 degree field of fire. Range is 50,000km, MHS=2, cost is 18,000Cr and 20 cubic meters of space is required for an IB. Uses the Laser Battery computer program.

FORWARD FIRING ROCKETS (FFR)

Essentially the launchers from a rocket battery positioned in a forward firing stance. All RB modifiers apply (range, DTM, damage), a variant of the Assault Rocket program is used to operate the system. MHS:1, cost = 20,000Cr, and requires 20 cubic meters of space

STRIKER MISSILE (SM)

A Striker Missile rack holds two missiles, each rack requires 5 cubic meters. The rack costs 1000Cr and individual missiles cost 5000Cr each. Missiles have a range of 60,000km with a -10 damage table modifier and inflict 1d10+2 damage. MHS:1 and MR:4 or better required, and a LVL:1/fp:4 computer program is needed to operate the system. MPO/LTD weapon

HEAVY BOMB/ROCKET (HBR)

These nasty propelled bombs can do some serious damage, especially when considering they can be launched from small craft. The launcher costs 10,000Cr and individual bomb-rockets cost 20,000Cr. Launchers require 10 cubic meters and the range for the bomb-rocket is 30,000km, damage is 3d10 with a -20 modifier. MHS:2 with MPO and LTD restrictions. A LVL:1/fp:3 program is required to operate the system

WARHEAD LAUNCHER TURRET (WT)

A Warhead Launcher allows the use of Striker Missiles, Assault Rockets, and Heavy Bomb-Rockets on larger ships. Essentially it is a turret weapon sporting the respective launchers. The allocated space for a warhead launcher turret is 20 cubic meters (plus the 20cubic meters of space from the weapon systems for a total of 40) and cost is 20,000Cr plus the weapon systems. MHS:5 with LTD/MPO restrictions, and a LVL:2/fp:8 program is required which will operate any of the three weapon systems installed. The launchers will hold 8 striker missiles, 2 assault rockets or two HB-Rockets depending on which systems are loaded. Combinations are possible, such as 4 striker missiles, one assault rocket, and one HB-Rocket.

PARA-MILITARY FREIGHTERS

Ranging in size from HS:3 to 20, these freight haulers are reinforced and upgunned yet retain most of their stock freighter performance figures. When a PM

Freighter is commissioned, it is usually done so under a government charter with the owner(s). There are typically established trade routes that the ship will head to with steady cargo schedules, and while the owners are under this chartered route all operating costs are taken care of, and payments are made on the loan by the chartered government, but there is no profit being made off of any cargos at the same time. The owner(s) are given one forty day period of leave time for every forty day period that they work. However, on that free time the owner is responsible for all costs and is eligible to make any profits off of any cargos that are obtained. Naturally no illegal conduct is permitted during such time. PM Freighters are permitted (HS x 20) cubic meters of space for weapon systems and (HS x 12) cubic meters for defensive systems. Defensive and offensive allocated space is not interchangeable, any unused space is unused. Crew size is typically (HS x 2) members, hull points equals (HS x 6), DCR is calculated at (HS x 5)+30, and cargo is reduced by one unit for freighters HS 4-8, -2 for freighters HS:9-14, and -3 for freighters HS:15+ .

STREAMLINING

Ships up to HS:5 can be streamlined to enable landing on atmospheric worlds, at +10% of the normal cost of the hull. This can only be performed during construction of the ship.

ARMOR PLATING

Ships can be armored with thicker hull plating and more durable bulkheads and framework. This can only be performed during construction of the ship, and is only available at Class:1 SCCs. Light armor doubles the cost to HS x 100,000Cr and provides 6 hull points per hull size, medium armor doubles again to 200,000Cr per HS and provides 7 hull points per hull size, and heavy armor doubles once more to 400,000Cr per hull size and provides 8 hull points per hull size.

GRAVITICS/INERTIAL COMPENSATORS

Streamlined ships can opt to have their decks constructed parallel to their main axis rather than perpendicular, thus allowing their crews to operate normally when the ship is on the ground. While in flight, artificial gravity can be enabled as long as the ship is either coasting under no acceleration or accelerating at no more than 1g (ADF:1). The equipment costs (HS x 100,000)Cr and can only be installed during construction.

(Campaign Note: I am slowly phasing this out of my game as I redesign my deckplans so that all my ships are decks-perpendicular to the main axis)

UNIVERSAL AIR DOCK

Trans Travel released this useful concept of a universal docking collar. It allows any two ships thus equipped to dock and allow their crews to access each vessel without the need for space suits. The collar portion extends past any extensions of the starship to connect with the other vessel's own collar, and the two interlinked air locks are then pressurized to allow easy access between ships. Cost is 10,000Cr and MHS=3.

ADVENTURE!

RACE BEYOND THE FRONTIER

By Larry Moore

BACKGROUND

As the hulk drifts past a UPF monitoring buoy a signal is intercepted by Strel One.

Aboard Strel One.

[Flashing red light]

"Err. Captain?!"

"What is it?"

"A signal from UPF buoy Tango-Seven, Tristkar sector."

"Tristkar?!? Helm FULL SPEED to that signal."

Later that hour....UPF Headquarters

"I don't know Schmead, better send a scout to investigate. It's gotta be real with something that large and it's unlike the Sathar to, well, what we know of them, to be in Tristkar. They would have to cross the White Light Nebulae and nothing has been reported from Outpost #1."

Yet later that day....UPF Outpost Tristkar sector.

"Glenn are you kidding? This is *his* job." Billowankers points to a gruff looking Yazarian, his mane matted to his sweaty forehead. Sitting in one corner of the mess hall the Yazarian curls his lips to show his teeth.

"I say what I say's. Your going!" Captain Glenn pounds his fist on the table.

Life at the outpost was no picnic. Conditions were harsh inside the hollowed out asteroid. It was stuffy, hot and usually run by rookies where they couldn't cause any trouble way out here. For 15 minutes they had speculated about the signal until the conversation spiraled downward into utter fear of the unknown. Now UPF HQ wanted a visual.

Billowankers started to suit up, ready to board the drifting hulk. "This is crazy." he thought to himself,

"I'm not a spacer, I just wanted the Military credits for school."

"Billow, were secured. Prepare to board." Came a voice from the intercom.

"Roger that." Then turning to his Compu-Pal, "Hey Bit, you ready?"

"mmmMMM. Yeppers Billowman."

"Stop calling me that, and what's with that humm?"

"mmmMMM. HummMMM? Don't you mean mmmmMMM? I'm feeling strange, like something is causing interference in my voice box."

Bit was Billowankers only friend on this miserable post of duty. He thought that he wanted excitement and now that he was getting it he realized he just wanted a free ride through grad school at Zebulon University.

Deep breath. Laser rifle settings check. Pressure check. "Bit, I'm gonna strap this tether on you in case you malfunction."

"mmmmMMM. Ok Billow."

As the hatch opens Billow sees nothing. Absolutely nothing. Billow flashes his lights face forward. A long shaft appears and he notes the ancient looking metal bulkheads. He walks thru the hatch, magnetic boots easily attach to the alien hull. One step. Two. This corridor is very different than any type he is famulure with. The far end of the corridor the hatch is triangular. A faint glow comes from a control panel nestled in the bulkhead to the right of the hatch. Just as he reaches for what he supposes to be the "open" button he hears a hiss's as the hatch begins to open from the middle out in all directions.

"Ghhaaaaaaaaaaa."

Captain Glenn, "Billow, what's going on down there?" "Billow, answer me now!" (faint noise of fists slamming against a control panel.)

"Errgh. Sorry sir. The alien hatch caught me by surprise."

Captain Gleen. "Stop your fooling and get on with it...." His voice trails off. "Kit'Kaat, you reading something on the sensor array?"

Kit'Kaat: "Yes sir, but it's not coming from the alien ship."

Captain: "You better tell me what in tarnashion your reading."

"Yes Captain, it appears to be coming from behind us, very faint. I'll keep an eye on it."

Captain: "Billow, make it quick, get in and out with sensor data. I want to depart in 15 minutes."

"Roger that Captain." Billow replies.

Billow lights up the open hatch. "Bit you getting video of this?"

"mmmmMMM. Yes. I'm scared."

"Your not programmed to be scared you rust bucket!"

"mmmmMMM. You altered my functions Billow, I'm not your average Compu-Pal."

Bit was right, Billow had tinkered with his Compu-Pal ever since leaving father and mother to join the UPF Academy. Bit now boasted level 6 intelligence with an added video recorder. Billow wanted to add a small laser pistol but Bit was already pushing his hover-weight limit capabilities.

On and on Billow went, hatch after hatch until he reach a long room with glass tubes about 3 meters long and .75 meters wide nestled against each wall at a 45 degree angle.

"What are these?" He thought. Billow was feeling queezy. About 5 minutes ago he lost chronocompact contact with the Captain but knew he had a mission to finish and was well within the 15 minute time frame the Captain ordered. "Bit, you getting this?"

"mmmmMMM. But of course Billow, I'm not a cleaning bucket you know."

Billow laughs out loud. "Your lucky I didn't let w00t the Yazarian turn you in to one buddy."

Suddenly Billow slumps forward his mag boots holding fast to the floor.

"mmmmMMM. Billow!"

Bit turns off his video recorder and maneuvers back to Billow, catching him under the chin of his space helmet. He looks into his masters (Bill, need a better word here.) eyes. "mmmmMM. Billow! I'm scared what do I do?"

"...(crackle)...illow. (crackle) is your status? Repo... (crackle)..."

Bit. "mmmmmmMMM. Captain, Billow is unconscious!"

No answer.

Bit runs through his "what do I do in a very critical moment logic circuit." Nothing seems logical right now. Bit decides; "I must get Billow to the ship." Billow drops down to Billow's mag boots and extends a small cylinder from his body and touches the side of each boot which releases the magnetism. With the magnetism deactivated Billow slowly starts to float in Zero-G. Bit spins around and around to take

up the slack from the tether between him and Billow. Bit replays the video from his memory banks to make it back to the ships hatch tugging Billow behind him. Once in a while the corners are just to tight and Billow slams against the bulkhead never conscious of his surroundings or what his faithful Compu-Pal is doing to save his life.

Finally safe at the ship one of the MedTech's begin extracting Billow from his space suit.

Meanwhile on the bridge.

Kit'Kaat, "Confirmed Captain, it's an Assault Scout headed straight for our position bearing mark 374."

Captain Glenn, "Marcus, is the hatch feed disengaged?"

"Yes Captain."

"I want full thrust straight back to base. Gunner get those weapons online!"

"Kit'Kaat, can you identify that craft?"

"Negative Captain. It could be pirates." Kit'Kaat responds unsure of his own answer.

"And I say "negative" back at you. There is nothing of value in Tristkar for Pirates to be poking their nose into." The Captain yells and slams his fists on the control panel.

KNIGHT HAWKS SCENARIO

Fire fight between UPF Scout and Steel One. Use KH Basic rules. You can download them from here: <http://starfrontiers.us/node/328/>

UPF Charr'd Assault Scout

Hull Points: 15

ADF: 5

MR: 4

Weapons: 4 assault rockets, laser battery

Defenses: reflective hull

Steel One Assault Scout

Hull Points: 15

ADF: 5

MR: 4

Weapons: 4 assault rockets, laser battery

Defenses: reflective hull

Setting Up.

Use the hex map from the Knight Hawks boxed set and counters to represent the ships.

The Charr'd is docked on the far side of the alien spacecraft. Place these ships on the long side of the map. Steel One starts at the opposite end of the map.

Victory Conditions.

UPF wins if they manage to get back to the asteroid in one piece. Steel wins if they disable the UPF Scout enough to gather data from the hulk.

ROLE PLAYING

In this adventure you can play for Streeel or the UPF. With a minimum of four PC's, advanced GM's and players can play 2 PC's per side and have some lovely banter across the gaming table.

If you choose this adventure and the Players decided to fight it out, two, three or all Players may be watching from the sidelines if their PC's are killed.

Streeel: You're hired by, what was that guys name again? Who cares, money in the bank is money in the bank and based on the amount of deposit this was not going to be easy. Your team is hired to investigate a top-secret find by a UPF outpost in Tristkar.

- **Meeting the contact/guide.**

A large Yazarian gives you passes to the local spaceport.

- **Boarding a UPF supply ship.**

The PC's must find a way to stow on board or replace some of all of the crew. If they replace the crew they will need access to passwords used to enter the Tristkar system.

- **Flight to Tristkar.**

You can insert a random adventure here.

- **Arrival in Tristkar.**

Upon arrival and undocking all the cargo you find out the "precious cargo" you have been hired to find and track is leaving in 4 hours aboard a UPF Assault Scout (AS). You can choose to "stage an accident and take control of the ship." -OR- "follow this ship."

- **Staging the Accident.**

Your team stages an accident aboard your freighter, making your way to the AS and taking off.

Star Law: Your team specializes in the unknown. You have a mentalist onboard, a resource that is frowned upon by the badges but they know they need you on this one. One man lays in some kind of comatose due to an encounter with an unknown. Your team will not be briefed until you reach your destination, somewhere in the Tristkar sector.

Typical badges.

(Players should react to Star Law looking down on them)

- **Hired by the UPF.**

- **Attack at the spaceport.**

Your team is attacked at the local spaceport. It appears they are trying to take over a UPF supply ship and you got in the way. They kill your escort/guide.

- **Flight to Tristkar.**

Your escort is dead you now have to face a hostile crew and Dr.

- **Encounters with the crew**

Dr. Ford Prefect

- **Arrival in Tristkar.**

As you enter the system you notice the registrar list the supply ship from your local spaceport.

- **Leaving Tristkar system.**

A freighter sends an emergency signal that their engines are overloading and they are unable to jettison them. Some of the crew aboard your ship leaves to assist. A few rounds later you are attacked by operatives trying to take over your ship.

WHAT'S THE HOLDUP

By Michael O'Dell

This is a quick module for 1-6 players with no longer than 1 to 1 1/2 hours play time.

Place: White Light or any City setting.

Object: This module will have 3 main objectives to complete depending on the PSA of the characters:

1. **Medical skills:** Assist and recover the wounded NPC's - there's a Vrusk (male), Human (female), and a Dralosite (male stage).
2. **Technical skills:** There's a briefcase locked (level 1) in the trunk of the P.G.C. hovercar that needs to be recovered before police have a chance to locate it.
3. **Military skills:** There is a Space Pirate holding 2 hostage's that needs neutralized.

Start the module by having all players incorporated by P.G.C. If this is a group with many different employees then have this job subcontracted out. If at all possible have them all working for P.G.C. in whatever their main skill area is. Example: Medic character working for the P.G.C. med lab, Technician character working in R&D or the repair shop, Military in security, etc.

BEGINNING:

Read the following to the players:

It's 7:45am Monday morning and you are still some distance to work when your chronocom notifies you that you have an incoming message. After a few seconds you answer it. It's Dan MCGown, your new division supervisor.

"Good morning. How's P.G.C. finest? I know you are still on your way to work but I have some pressing matters. It seems one of our vehicles is involved in a bad accident down on 1117 north main street. Since most of our people are on vacation I'm needing you to go check it out and assist the local Star Law on the matter. That's all I have on the subject at the moment. I'll call you when I have an update. Good Luck and be safe"

As the picture blinks out on the chronocom you think to yourself: *just my luck - already being errand-boy!* Not a good way to start the week. You tell the cab driver to take you to 1117 north main street.

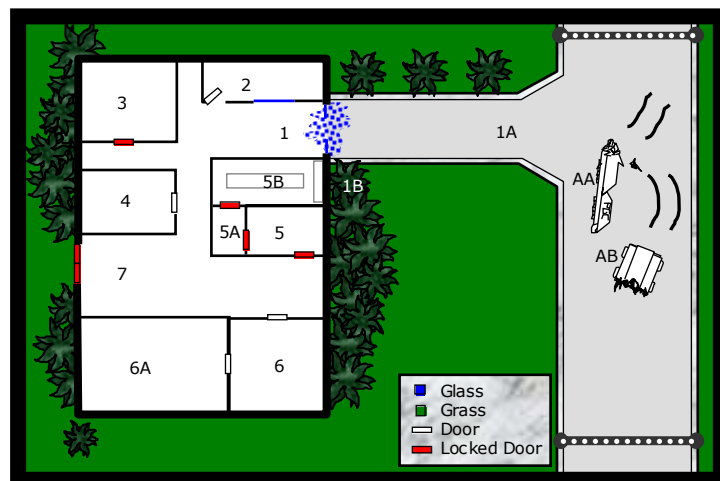

GM: As the cab gets close to the address, Draw an outline of the building. Place an explorer counter at AA and a hovercar counter at AB (on its side), place three NPC counters at 1A. Block off all streets around this building with 2 vans, 6 Star Law ground cars and 1 ambulance. The cab will have to drop the players off outside of the blocked-off zone.

At this time have all players arrive together. Set up a count-down of dice with 20 turns. This will be a timer for the 2 hostages with TD-19 in room 2.

Read the following to the players:

As you arrive at the scene you notice half a dozen star law ground cars and 2 vans with the Letters S.W.A.T. on their side. By the looks of it they have blocked off this section of road. The cab comes to a stop just outside of the blockade.

The cab driver says "This is far as I can take yah... looks like there's been a major accident. Your total is 15cr."

After you pay the cab he thanks you and drives off. As you walk closer to the few Star Law standing behind the blockade you notice a Vrusk, Draliste, and a female human on the ground some distance in front of you. The building reads "Greenlawns Pharmacy."

GM: This is a building being held up by Space Pirates. For every 2 players there is 1 pirate, so a group of 6 players would face 3 Space Pirates in the building.

The Vrusk, Draliste, and human have been shot by a high power sniper rifle from pirate A. The hover car is PGC's. If any players are Techs ask them what they plan to do then read the following:

As you start to head out, your Chroncom alerts you to an incoming call "Hey crew this is Dan again - seems that one of our cars was carjacked and the local law enforcement has located it at that address. It seems the suspects drove it to that location for an unknown reason. This is bad news for us here at P.G.C. because there's a briefcase in the trunk of that car we need to secure. I understand this is not normal assignment work so we'll place you on hazard pay and cover any medical expenses you might require. By the way, it's best if Star Law isn't informed about the briefcase. Report back when you finish up there."

The com goes silent. If the players check the trunk of the hovercar they will find it locked (lvl 1). If they check the ignition they will find the keys there. Also quite a bit of blood in the passenger seat. There's a 10% chance that pirate A will see the players opening the trunk and fire on them. If that happens and they remove the briefcase there is a 40% chance that Star Law will see them doing so. otherwise there's only 5% chance of star law seeing that action. If players decide to open locks on the trunk (instead of getting keys) then they well have no problems with recovering the briefcase unseen.

When the players reach the vehicle at AB, read:

You manage to make it to the hovercar. You can smell strong acid coming from the chemical cells of the parabattery from under the hood. You also see a small

amount of smoke starting to rise. You hear a human's voice come over a bullhorn.

"Were sending in a man with a secure link like you requested! Please hold your fire!" You see a human in full padded armor advancing to the doorway.

GM: This is a good time for the players to try and retrieve the briefcase since most of the NPC's are being distracted at the moment. If some of them want to try to pull the bodies out of harm's way they will be able to do so but they will need at least a combine 65 STR to move the Vrusk. Allow them to move them behind the hovercar or a zone wall. If players enter 1B this area is mined with 4 "digger mines" in the grass.

Digger Mine: This is a self-concealing mine thrown on the ground or other soft surface. The mine is the size of a hockey puck 3" x 2" thick. The mine uses sonic waves to bury its self once set and thrown. Each mine does 5d10 damage in a 2-meter radius. There is a 15% chance that if one should explode the others will chain-react. Players have LOG check at -10 to notice the mines. These can be disarmed, treat as level 1.

After players take there turn, if pirate A is still alive read following:

You notice the human stop a few feet from the door. From your distance you can't quite hear what he's being told but soon after you see him toss what appears to be a subspace radio hand-piece to someone inside the building. The sound of two shots are heard and the human is knocked back a half a meter, landing on his back.

You hear the man with the bullhorn swear a few words under his breath.

If players inspect the body he's dead: 1 shot to his vest in the chest the other a critical shot to the head.

ROOM 1

You enter the front entrance. The glass door is broken out. Just inside to the right is a booth with a heavy glass window much like what banks use. You also see a door at the far end of the booth that stands open. A rather large human dressed in black leather holding a rifle and a small device with a red button on top smiles at you as your enter.

GM: Pirate A is named Art Ritten. He will show the players the remote device and threaten to blow him and everyone else up if they don't drop their weapons. If the players attack he well do either one of two things depending on if he wins initiative: If he goes first he will fire 3 shots from his rifle. This is a custom-made rifle that does 2d10, double damage if he rolls doubles on his hit roll. If he doesn't go first he will try to detonate the TD-19 on subjects in room 2.

Pirate A: RW 65% MW 30% Sta 65 Str 45 Sniper Rifle with Infra Scope (1700cr) Star Law will want this weapon for evidence). He also carries a CredCard with 350cr on it. If traced, it's an off-planet account under the name Vancam Corp. (note player needs computer skills to get pass pin code or have connections to someone with that skill. There's a red devil tattoo with white stars on his right arm. The Yazirian and Human in room 2 each have a belt strapped to

them holding 50kg each of TD-19. If set off, that's 10d10 in an 18' blast range.

The current counter on the belts are however many turns left on the dice from the start of the adventure. Both have a chance of being disarmed by someone with the Demolitions skill. If no one has that skill have a team of Star Law bomb squad show up and remove the devices after room 1 is clear.

ROOM 2

Read the following as the players enter room 2:

This room is 3 meters wide 10 meters long. The door has been blown open. There is female Yazrain and a male Human tied up and blindfolded. They both have a belt of explosives fastened around their midsections. This room looks like it once held shelves of containers but is empty now.

GM: This is where people pick up their prescriptions. The Yazirian and Human are employees, and are dressed as such. If the party did not reach them before the dice turns ran out or if Art the Pirate pressed the button, then this room will be a mess and you should describe it as such. Art will try to leave 3 turns before the timer runs out through the back door.

Both employees have name badge cards that can unlock the back door and turn off the alarm at the back entrance. The pirate Art will have a key on him for the padlock that's also used on the back door.

ROOM 3

Read the following as the players enter room 3:

This is a large office area with a desk and chair along one side. Rows of filing cabinets line the wall.

GM: This is where they keep hard copies of the customers medication histories. If players search the desk they will find a first aid kit along with a laser pistol in the top drawer with a full powerclip. All records will be useless (unless they have a job from a certain client to recover them -- this could be a side job if the Referee wants to add it in).

ROOM 4

Read the following as the players enter room 4:

This room is unlocked. As you open the door you see a break room with 4 tables and a dozen chairs. In the back corners there are 3 vending machines and a cheap large screen monitor near an ugly gray couch.

GM: Time for a soda break. If more than 2 players are playing, this is where the 2nd pirate will be. He will fire with a laser pistol set on 3 then melee when out of ammo. There is nothing else of interest in this room.

Pirate B: RW 55% MW 25% Sta 55 Str 45, Laser Pistol (3) 1 clip

ROOM 5

Read the following as the players enter room 5:

This is a small room with lots of computer terminals to the west there's another door with another security panel to its left.

GM: The security lock on this door is level 3. Anyone with computer skill can try to use the computer in room 5 to open this lock. Any Tech can try to unlock it as well.

HALLWAY 5A

As you enter this small hallway the temperature must have dropped at least 30 degrees. On the north end of this hallway there's another door with a small window in it. You also notice 2 biosuits hanging up on the east wall. There's a security panel to the left of the door.

GM: If players try to see through the small window in the north door they will notice what appears to be a blue glow coming from this room. The blue glow is ultra violet light. Again the lock is level 3 and can be bypassed with a successful roll like in room 5.

ROOM 5B

This room is dimly lit except for the ultraviolet lights that are glowing a strange blue. You can't help but notice the large amount of plant life in this room. Many of the plants you have never seen the likes of. Along the east wall there are large metal cages. Down the center of the room there is a large table covered with different plants. This room's temperature is close to freezing.

GM: If any player enters this room without a biosuit there's a 60% chance each turn that they will be infected with a disease S10T6. There're thousands of spores in this room. If the door is manually kept open after 2 turns an alarm will state that temperature is approaching critical levels. If the door is left open for 2 more turns the plants will start shake -- releasing their spores. Anyone exposed will have a 99% of being infected with disease S20T10... if not cured or taken to a hospital quickly they may be in serious trouble. (Referees should allow a saving roll with STA or less to notice if they are infected). Any of these plants or part of a plant will be worth anywhere between 100cr to 1000cr. The cages are empty except for some hair and a few blood spots.

ROOM 6

This room is large and filled with boxes of papers. It looks to be year end accounting along with some old signage of the building on the west wall there's another door. Does not look like this room gets much use.

You notice a Pirate lying across a layer of boxes. He seems to have fallen asleep.

GM: Storage room has nothing of real value. If the players set off an alarm and there are 6 players then this is the 3rd pirate. He will exit this room if the alarm is set off. If not the party can catch him asleep in this room.

Pirate C: RW 45% MW 25% Sta 60 Str 50 Auto pistol 20 round clip. If caught alive +1 exp to each party member and an extra 150cr reward. He will give up if the party catches him asleep and removes his weapons. If not he will fight to the death because he's cornered.

ROOM 6A

You enter this room and hear the quiet humming of the large generator, from all the dust in this place the equipment has not been maintained for some time.

GM: This is a type 3 generator. It runs the computers in room 5 and the freezer in room 5b. Players can recharge their belt packs and power backpacks with this generator but only 2 at a time. It takes 2 turns for a belt and 5 turns for a back pack.

HALLWAY 7

This hallway has a door on the southeast end and a door across from it on the northeast end. There's another hallway branching off to the north. You notice a security panel on the northwest wall just before the back exit door. The exit door seems to have a chain wrapped around it from the inside. A large padlock keeps the chain secure.

GM: The padlock that locks the chain was placed there by the pirates. Art has the key for it. If players enter from the back there's a camera mounted outside above the back entrance/exit. If they break the door glass to enter they have 1 turn to deactivate the alarm by using the panel just inside on the north wall. If they fail this will activate the securitybot located at the end of hallway between rooms 3 & 4. This also alerts the pirates that someone is entering from the rear door.

ENDING:

GM: If the players entered/exit from the rear door have them encounter a team of Star Law S.W.A.T. asking them to drop their weapons and identify themselves. After Star Law accepts that they are not pirates, they will be escorted to the front of the building.

If the players capture/kill Art the Space Pirate in room 1 have the S.W.A.T. group move in and assist the players since they came in through the front. Local law-enforcement knows they are from P.G.C. and are here to help. As they start to leave the crime scene read the following.

As you start to leave the crime scene a tall yazirian approaches you. He is wearing a Star Law uniform. You can tell by his ranking he's a captain. he says "I just wanted to let you know how much we appreciate your help in this matter. I'll personally be putting in a good word for you in my report.

If some one has the briefcase read the following:

He start to turn an leave but notice the hidden briefcase he give you a sharp look an says "What do we have here?" pointing at the briefcase.

GM :At this point let the players explain. Whatever they tell the officer he will ask what's in the case and where it came from. No matter what they tell him he will let the player go but will tell them he has to put this in his report. If the players try to bribe him he will try to arrest them and take the briefcase. If the player was able to sneak the briefcase out or left it for later in a hidden spot to come back for it then ignore the last part of this encounter.

Star Law: RW 65% MW 35% Sta:70 Str:50 IM:6 Laser Pistol(5),Belt Pack(50) Albino suit(100)

Note: What this does is open up another adventure to recover the briefcase if Star Law confiscated it, or be

attacked before the players get a chance to return it to P.G.C. The briefcase contains top secret plans for a new type of fuel cell. If this briefcase is taken by Star Law there's a good chance this will leak out, costing the company billions of credits. If the players find out about the plans there are lots of people that would kill to get this info, one of the main reasons P.G.C. sent them so as not to raise suspicion about the case.

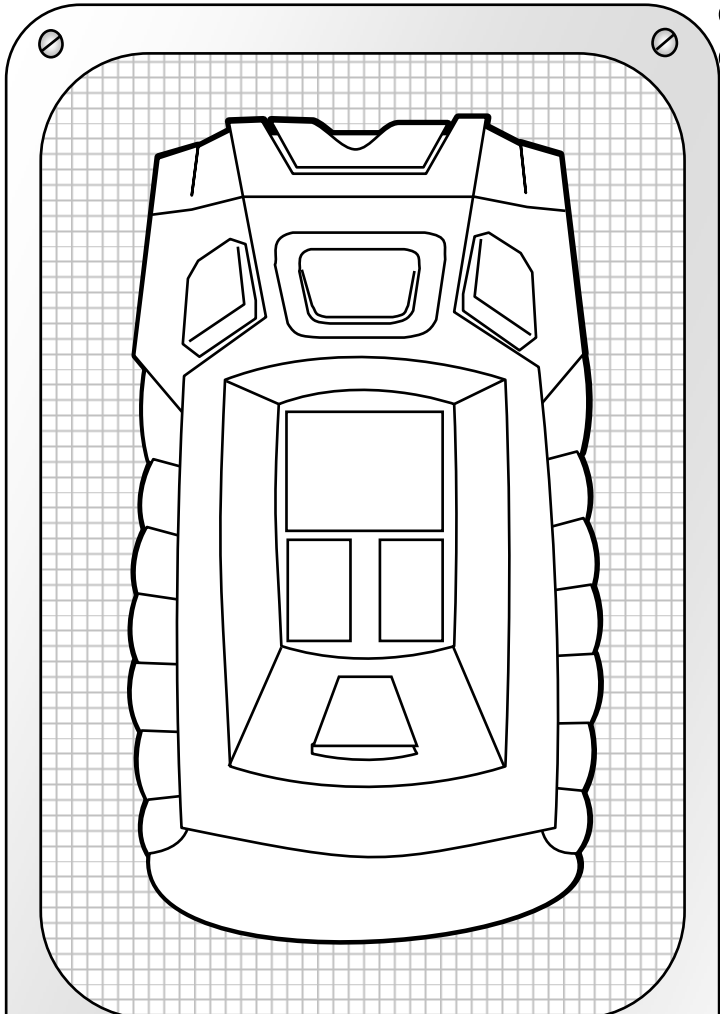

WHAT IS THIS?!

Is it a weapon? A portable computer system? A Compu-Pal? Garage door opener for you aircar? You tell me.

Create this piece of equipment for inclusion in the next issue of the StarFrontiersman. It has four buttons that I can see... and the center area could be screens or displays or indicators... it has to have some use!

If you have an idea for a new piece of gear – or have some drawing talent and want to add it to the "What Is This?!" teaser for next issue – just drop me an email.

-Referee@StarFrontiersman.com

COMMUNITY BUZZ

A chance for you
to talk...

New Star Frontiers Project:

Races of the Frontier and Beyond (By Greg Rapp)

Some people prefer only a handful of races for Star Frontiers, some of you like the idea of a Frontier melting pot full of varied species. Many of you have seen what the Star Frontiers Revival has been up to. Now one of the projects for this game is taking place to give you (Referee or player) a choice to see more races of the Frontier and beyond it. I am writing this article to ask any and all Sci-Fi or Star Frontiers gamers to send us your materials for newer PC races. They are currently being compiled/transformed into a massive source book for the Star Frontiers Role-Playing Game.

From the current forum discussions the rest of the members of www.starfrontiers.us and I have decided on these guidelines for the sourcebook:

The four core races of the Frontier are the only spacefaring races. Others inside the Frontier may be considered close to obtaining interstellar travel (in their Digital Age or below). The book will contain a maximum total of 34 races that will live in the Frontier. (incidentally, the "Frontier" will be assumed to be near the center of a galaxy to explain the close proximity of so many star systems). The Sathar, for example, are considered an invader and are unnatural to the Frontier, therefore not counting towards this 34 limit and belonging to the "Beyond the Frontier" category. The galaxy beyond the Frontier will add up to sixty or seventy races (which will make a total of 100 PC races). More than half of these races will be considered spacefaring or close to it.

We have some fleshed-out in the pages of the StarFrontiersman and from other sources. What I am asking is for another 15 or so Frontier races and seventy or so "Beyond the Frontier" races. If you wish to learn more just email me: grapp09@dulceschools.com or webmaster@rpg-realms.com. If you have some ideas for PC races (or wish to help illustrate) send them in traditional Star Frontiers form to my email with your pen name or real name so you can receive credit. Watch an upcoming issue of the StarFrontiersman for a short sample of the book.

-Greg Rapp

D100 Tables

A request for open collaboration

I love d100 tables. Just love 'em. I like rolling on them and I like using them in-game. Back in the 80's we did lots of stuff with them. They're helpful in generating random events, selecting random equipment, giving random plot hooks... just about anything. Over at www.starfrontiers.us/node/1277 I'm asking for help in generating 100 individual character backgrounds. When it's done, I'll publish it in this book to give folks who are just starting the game a place to randomize their first character's upbringing and basic story. I want them set in the Star Frontiers setting but be able to be played by any race... here is the first one:

- 01** You were left for dead in a dumpster in an alley on Hargut (Gruna Garu - mostly Yazirian planet). Found sickly and starving, you were placed in government sickly care and sent from foster family to foster family, mostly just laboring for them before being kicked out again. You have trouble trusting anyone, you've learned to fend for yourself, you're always able to see other people's selfish intentions... and you generally think the world hates you. So far you've been correct. However, as you will soon learn, you were dumped there for a reason. You are not as you seem... but what are you, and what will it mean to the Frontier when your true nature is revealed and you step up into the prophecies you're destined to fulfill?

-Bill Logan

NOTICE

You have something to add to the Community Buzz? Email me at Referee@StarFrontiersman.com or send me a Private Message at www.starfrontiers.us. I'll add it in next issue. You don't have to keep it related to Star Frontiers if you don't want to... baby birth announcements... looking for players or gaming stores in your area... ads for your services... whatever. I'd prefer it not be too long (a column at most - which takes up about a page of text with default font/settings in Word). Wouldn't it be odd to tell your friends you sold your car because of an add you placed freely in the Community Buzz of the StarFrontiersman?

CLASSIFIEDS

TANGLER TAG!

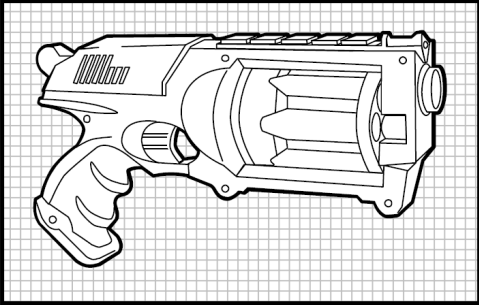

Tired of that painful singing laser?
Missing an ear?

Come down to Oh Golly's and
"Have yourself a 'nade war!"

Tanglers are safe and fun for
the whole family!

Tangler Gun provided upon request.
Use of the Tangler Mine Field extra CR.
Parents to provide own Solve-Away.
Children must be accompanied by an
adult or Dralasite.

Chronocom Subspace Relay#
77773375372816151226



THE BROTHERS FOUR

Red Devil. We know.
Make is easy, make it hard.
We don't care.

"TBF, Sathar Hunters."

Chronocom Subspace Relay#
55930308821816151212

SECTOR 6 NOW HIRING

Travel to the unknown location of the ultra-
top secret Sector Prime for interview.

If you can find us,
you are hired immediately upon arrival.

TIRED OF RUNNING

Wanted: Groko Ahmstadt
Description: Dralosite, resembles a bowling
ball with appendages. Wears a
suit with three pant legs.
Reward: 15,000 CR.
Reason: He wants me. We split the
reward.

Chronocom Subspace Relay#
22654308822327151891

FREEZE FOR LIFE

Awaiting the coming messiah?

Freeze yourself away only to be
awakened at the climactic moment of
his/her/it's/their/ return.

Want to cash in on your father's will while
you're in your prime?

Outlive your enemies.
Personal protection guaranteed.

Over-weight Dralasitas cost 10% extra.

Chronocom Subspace Relay#
67354308822327151891

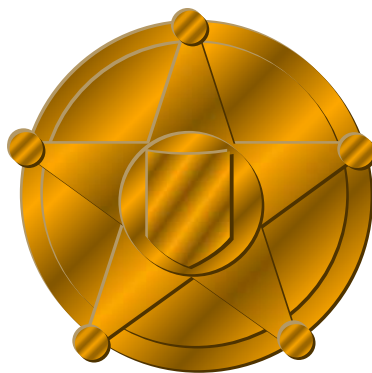

*Get a badge.
Carry a gun.
Get a cool nickname.
Wear sungoggles at night.
Be the envy of all your childhood
friends.*

MAHG MAR ASSOCIATES

looking for experienced environmentalists
to survey the planet for future
Top of the Dome living quarters.

Contact Captain Bill Terry

Chronocom Subspace Relay#
85515122886609351819

ASSAULT SCOUT MODIFICATIONS

We won't ask how you got it,
but boy can we make it purr.

Our technicians are all ex-military engineers,
with 45 combined years of experience
working directly with Assault Scouts.

- Streamlining
- Window Tinting
- Atmospheric Landing Conversions
- Gyroscopic cockpits

They say it can't be done,
but we'll make it land like an aircar.

All calls are treated as confidential.

Chronocom Subspace Relay#
85515122886609351819

STAR LAW

It's not just a career; it's an adventure and a duty
to your fellow being. Currently seeking
individuals for a few of the many branches of
this august brotherhood:

- Demolitions Disposal
- Counter-Espionage
- Trade Embargo Enforcement
- Uniform and Office Design

If you are interested, and aren't afraid of
enduring six long weeks of hard training,
contact us at...

Chronocom Subspace Relay#
000000000000000000

(and please – we've heard all the donut iokes)