

Post-Apocalyptic!

#1 — April, 2019

GAMMA ZINE



A Fanzine supporting early post-apocalyptic, science-fantasy RPGs— specifically, First Edition Gamma World (by TSR).

Gamma Zine! — A Note from the Fanzine Creator

I've wanted to create a small fanzine for Gamma World and other science-fantasy systems for a while but never seemed to have the time to squeeze it in. However, Kickstarter's recent 'Zine Quest' initiative was all the prompting I needed to finally produce a 'zine for fans of the post-apocalyptic genre. Hell, this fanzine is as much for me as it is for you!

Why a heavy focus on First Edition Gamma World? Well, I've always felt that there was little support and material for one of the earliest science-fantasy game systems made. TSR only made four products in this release before moving to the next edition. Additionally, the first edition is one of the simplest and easiest versions to learn and play, requiring only the 60-page rulebook to run short games or full campaigns. If you're looking to play post-apocalyptic D&D, this is where it's at!

In this first issue, twenty-eight pages feature three adventures, four new mutated creatures, loads of ancient artifacts and solution flowcharts, and a new class option.

Future issues will spotlight fictional characters and creatures, fleshed out with mutations and statistics for you to use in your games. Articles by well-known Gamma World contributors and fans will also grace the pages of upcoming issues. You may even find product reviews and articles about topics such as economic systems and combat mechanics—it all depends on what you, the reader, want to see!

I hope that you, a dedicated fan of the post-apocalyptic genre, will continue to support and provide feedback each issue. Thank you for purchasing the initial issue of **Gamma Zine!**

Thom Wilson

— Issue #1 Details —

Fanzine Sections	
Content	Page
Fanzine Creator Letter	1
Interview with James Ward	2
Horrors of the Wasteland	3-6
Class Option (the Artificer)	7
Artifacts of the Ancients	8
MuTech Test Facility (Adv #1)	9-14
The Hunted, Chapter One	15,18
The Hand (Adv #2)	19-21
Artifact Use Flowcharts	22-23
Dark Knights (Adv #3)	24-27
Information / Comic	28

GAMMA ZINE *v1n1*

Issue #1 — April, 2019
Created March 15th, 2019
Created by: Thom Wilson
Articles by: Thom Wilson
Cover Illustration: Je Shields
Back Cover: Je Shields
Logo: Thom Wilson
Comic: Travis Hanson
Interior Art: Je Shields, Dean Spencer, Forge Studios
Cartography: MonkeyBlood Design, Dyson Logos (commercially free maps)
Editor: Joshua Newey
Next Issue:
#2 — October, 2019 (or earlier)

1st printing—PoD edition

A Short Interview with James Ward

For our inaugural issue, we have a short interview with none other than the creator of Gamma World, Mr. James Ward! I'll ask Jim a few questions about the early days and his work on GW at that time.

Gamma Zine—How did Gamma World come about? Was there a call to create a science-fantasy RPG at TSR or did you want to create one and got approval from the company?

JMW—Metamorphosis Alpha was very popular and TSR got lots of mail asking for a planet based game so I wrote it.

GZ—How much of Metamorphosis Alpha was put in to first edition of Gamma World? Were there rules or mechanics in Gamma World that you wished you had thought of or used in MA?

JMW—The only thing from Gamma World that I wish I had put in MA was the cool figure-out items flow chart. I purposely tried to do different things in GW make to make it different from MA.

GZ—Why did TSR create a 2nd edition of Gamma World within a couple of years of the first edition? Were there more plans to expand the first edition of Gamma World that were canceled or put on hold?

JMW—TSR had a policy of doing updates for their games because most of the old customers from the first game would buy the second one.

GZ—The first edition Gamma World rulebook is pretty lean—only 60 pages. Were there things you had to omit to keep the book to its published length? Did you want to include anything that had to be removed for page count?

JMW—Those were the early days of role-playing design and there weren't a lot of design concepts figured out at that time. It was as full as we could think up in those days.

GZ—The cover of the Gamma World boxed set and rulebook are iconic—were there any other cover art pieces in the running or was this "the one" when it was seen?

JMW—TSR only had a few artists and they were kept very busy doing covers. This was the first one proposed and it was taken.

GZ—Any interesting stories of early Gamma World play testing you'd like to share?

JMW—Gary Gygax loved playing MA and GW because he rarely got to be a player in the game. He generally had to be the Dungeon Master in his games. However, he really hated the defects as a game element. When he got a character with a defect he didn't appreciate he would just kill that character. This led me to take out the defects in later versions of the game.

Thank you for your time and your work on GW, Mr. Ward!

New Horrors from the Wasteland

There are more horrors crawling in and above the radiated Earth than most survivors will ever see. In this section, we present a few new creatures with which to torture your players.

Spindling

What would you get if a spider and snake cross-bred? Well, something awful, indeed! The Spindling is just such a creature. It has a one- to two-meter long body, supported by six, arachnid-like legs. Its large mouth is filled with razor-sharp teeth, capable of rending a small creature in two quite easily. The top of its torso is covered in a thick carapace, providing adequate protection against simple blunt and edged weapons. The mutated creature is also moderately resistant to radiation (treat the creature's Constitution as 18).

The creature attacks by leaping or scurrying into position over a

victim, pinning it to the ground and biting it for 1d6 damage. It can also make one extra attack with one of its free legs, stabbing a pinned or nearby foe for 1d4 damage.

Most Spindlings are of the smaller variety. However, a larger, giant form of the creature has been spotted. This version is nearly triple in size but thankfully is found in smaller numbers.

The Giant Spindling attacks in a similar manner but deals 1d10 damage with bites and 1d8 damage with a stabbing leg. Additionally, the larger version of the Spindling is capable of swallowing a small victim whole after a successful bite (natural 20 rolls only). Swallowed victims are dealt 3d6 acidic damage each round until freed or dead.

Spindling

No. Appearing: 2-8

Armor Class: 4

Movement: 16

Hit Dice: 2

DEX: 16

+1 initiative

Spindling, Giant

No. Appearing: 1-2

Armor Class: 4

Movement: 12

Hit Dice: 6

DEX: 13

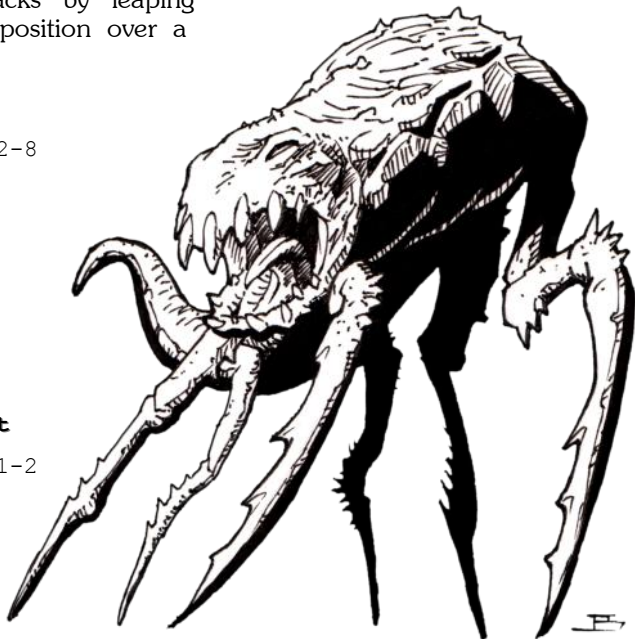

Unipede

Although starting as tiny, insignificant eggs, the mutated insectoid known as a Unipede grows to four or five meters in length by adulthood. Slithering upon several hundred stubby legs, the Unipede burrows through hard earth and soft rock with ease. The creature quickly stabs its head forward and back to chip away at obstacles in its path.

Additionally, the Unipede may expend part of its life energy once per day in an ultrasonic burst that softens material or causes damage to foes. When it uses this ability, it drains its hit points to half its current total. It heals itself over the next 12-24 hours of this expended damage.

Unipedes are attracted to high-density rock or metals, preferring to eat such material over fleshy creatures or plants. It can sense

characters within 25 meters that are wearing or carrying metal armor or weapons.

Ten layers of skin mixed with bits of rock and dirt cover the Unipede, giving it an impressive armor class. The Unipede is highly resistant to poisons and radiation (treat the creature's Constitution as 15).

When the Unipede attacks, it tries to burrow through a foe with its large horn. A successful attack by the horn delivers 2d12 damage. If it attacks with its ultrasonic burst, any living creature within 5 meters takes 10d6 damage.

Unipedes covet metal and high-density stones (e.g. raw or finished gems). Their lairs are often filled with stockpiled armor, weapons and precious stones, saved for later meals.

Unipede

No. Appearing: 1

Armor Class: 3

Movement: 4 tunnel / 12 ground

Hit Dice: 15

DEX: 12

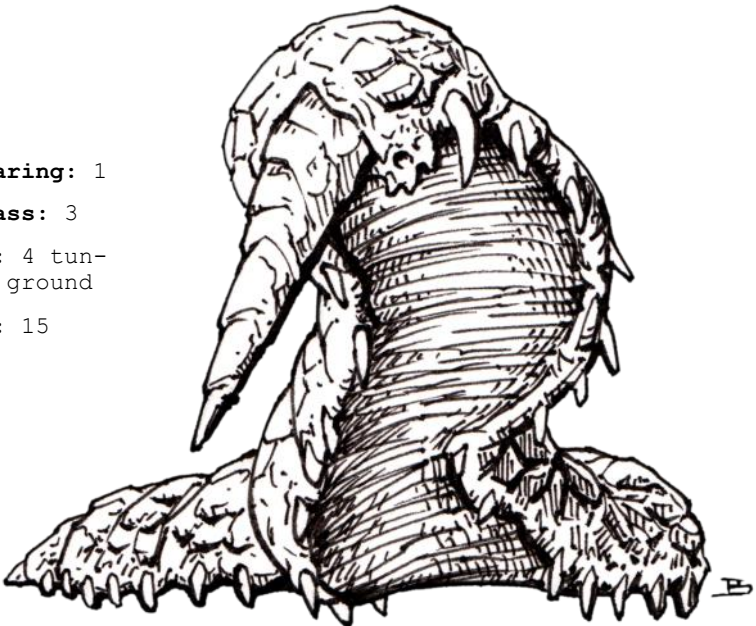

Shuggnagarath

No. Appearing: 1-2

Armor Class: 7

Movement: 20 (fly)

Hit Dice: 12

DEX: 17

+2 initiative



Shuggnagarath

Perhaps one of the most horrific and disgusting wasteland creatures, the Shuggnagarath scours the planet seeking brain matter to consume. With a wingspan of 8-10 meters, the approaching shadow of the diving creature is often seen before its form. That is, unless its foul stench isn't detected first.

When the Shuggnagarath attacks, it attempts to grab hold of its victim with its six tentacled arms. If at least two arm attacks are successful, the creature picks up its prey and flies off to a safe location to consume its meal.

During flight, it will bite into the head of its victim, starting the feast before it lands. A successful bite of the creature deals $1d8+1$ damage. For each tentacle arm grasping its foe, the Shuggnagarath gets a +1 to-hit with its bite attack.

If the GM rolls a natural 20 on a to-hit bite attack, the creature has successfully removed the brain of its victim. The Shuggnagarath cares little for the brainless bodies of its prey, often leaving them in its nest to decay. Much of the Shuggnagarath is covered in the rotting matter of its past victims—the reason for its foul smell.

Moleman

These highly intelligent yet mute creatures are most often found in ancient tunnels and underground lairs. They are capable of using advanced technology and ancient weaponry, matching the skill of any pure-strain human or humanoid.

They spend their lives digging for lost bunkers, abandoned facilities, and hidden technology. Unlike other wasteland scavengers, molemen are not interested in trading or selling anything they have found. They prefer to hoard their treasures, only allowing others of their clan to use the gear if needed. They often refuse to trade with other moleman clans unless they are working together to eliminate a common foe. This sometimes leads to violent clashes between clans.

Each moleman has an incredible sense of touch, hearing and smell (see Heightened Touch, Heightened Hearing and Heightened Smell mutations). Additionally, more than 80% of molemen are born with the Telepathy mutation.

Each moleman clan is led by one elder who has demonstrated his or her heightened intelligence (often having the Heightened Brain Talent mutation). Only one elder may rule a clan—the elder may be challenged at any time by any of the clan. Failure to take over leadership results in death.

Occasionally, a moleman is born with the ability to utter noises that resemble speech. Any molemen found to have this ability are outcast and are never allowed to return to their clan.

Moleman

No. Appearing: 4-16

Armor Class: 7

Movement: 12

Hit Dice: 3

DEX: 13

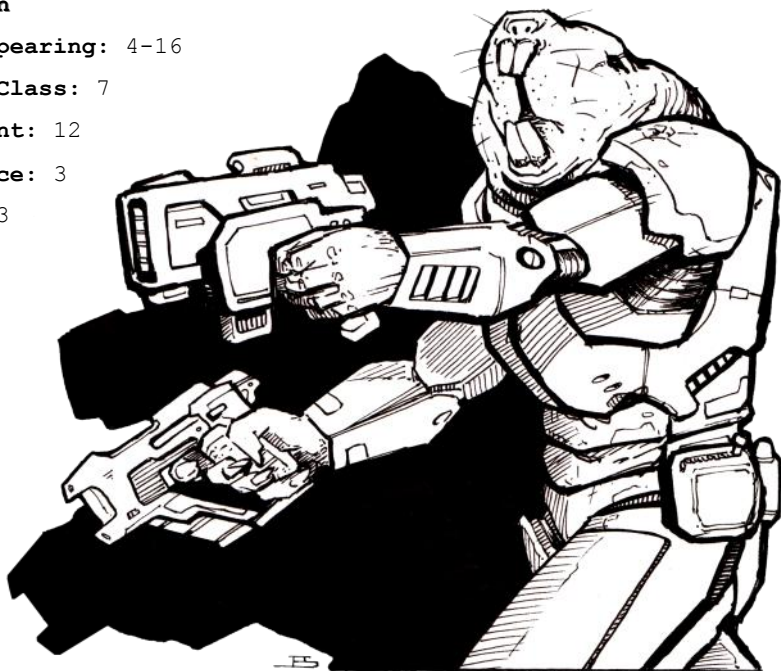

Class Option for First Edition Gamma World

First Edition Gamma World characters were created without formal classes. Instead, the focus was placed on races and statistics to separate characters from each other. Many who play this edition feel that the game doesn't require this level of specialization or categorization. However, some players in my past games wanted a class to help define their characters and to give them purpose or goals to work toward. In this issue of *Gamma Zine*, I offer a new class for your consideration: the **Artificer**.

An Artificer is a scavenger of lost technology, whether in pieces or as complete, working units. They have a knack for understanding old technology, repairing artifacts and building new items from the bits of broken pieces. Although they prefer to build devices for themselves, many use their abilities to find and repair items for resale.

Artificers must be *humanoid* with at least *two mutations* that assist them in finding and using ancient artifacts. A *minimum of a 15 for Intelligence* is required for a character to become an Artificer—a high intellect is necessary to identify and use ancient technology. Additionally, a minimum of one physical and one mental mutation are needed to allow a new character to qualify for the class (see the table in the next column).

Any time an Artificer attempts to search for artifacts, his or her chances are improved by one due to the class's affinity

for finding old tech (e.g. if a search requires a 1 on a 1d6 roll, it is instead a 1-2 on the 1d6 roll). When an artifact is successfully unearthed, the Artificer may subtract an additional point from their artifact use rolls.

Artificer Mutation Requirements

Mutations (1 min. of each type)

Heightened Touch (P)

Dual Brain (M)

Genius Capability (M)

Heightened Brain Talent (M)

Heightened Intelligence (M)

Molecular Understanding (M)

(P) = Physical, (M) = Mental

Artificers do not gain experience points from combat, instead gaining double experience points from identifying and using artifacts. Combat is just a means to an end, affording an Artificer the opportunity to acquire that which he or she seeks. Because Artificers are so enthralled with technology, they are often members of the Archivist or Restorationist Cryptic Alliances.



Artifacts of the Ancients

As scavengers dig under the rubble of the fallen world, they hope for a chance to find something of the ancient culture. Discovering lost and advanced technology is one of the greatest rewards of the hard work.

Type-III E-Fist

Short for “Energized Fist”, the Type-III E-Fist was an excellent weapon for close-quarters combat. Often used by soldiers seeking a quiet and effective method of dispatching foes, the handheld device delivers a powerful burst of stunning pain on contact. In addition to the damage it inflicts, it stuns the victim in the same manner as a Stun Whip.

Type-III E-Fist

Damage Inflicted: 1d6+1

Power Source: Hydrogen Cell

Battery Life: 10 minutes

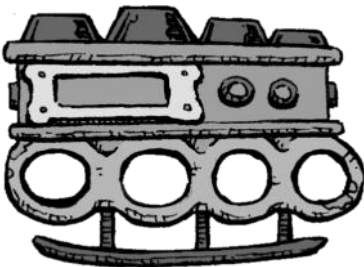

Pulse Grenade

A single-use grenade designed to inflict damage to robotic machinery and electrically powered units. It has no effect on living creatures unless they are within 3 meters of its exploding pulse (renders the living creature unconscious for 1d10 minutes).

Pulse Grenade

Area of Effect: 10m radius

Damage Inflicted: 10 dice (d6) per electrically powered target in blast area



KnifE

Unlike the Vibro Dagger, the blade of this cutting weapon is made of energized metal. It uses less energy, making its battery life twice that of other weapons.

Dexterous characters may also throw the KnifE effectively (minimum Dexterity of 15).

KnifE

Damage Inflicted: 2d6+2

Power Source: Hydrogen Cell

Battery Life: 60 minutes



Art by Je Shields

Adventure #1—MuTech Test Facility

Adventure Background

Rumors of a secret, pre-war facility hidden within the once-forested hills of Appalachia have reached the ears of the characters, peeking their interest for adventure and the rewards of lost tech. Although tribesmen and clans in the area claim that a clandestine bunker exists, not a single hint to its location or its contents centuries later can be discovered without a thorough search of the surrounding hills. All that's known is that a classified, underground facility was once in the region.

An adventure for 2-4 characters.

GM Background

In the months leading up to the Shadow Years, scientists of the anti-government group known as the Autonomists built a small facility in the Appalachian mountains to test and refine new technology through controlled mutations. Using impoverished locals, the scientists carefully tested a new compound that altered physical and mental states, often producing desirable enhancements in their subjects. Increased reflexes, amplified mental capacity and other super-human abilities were among those effects, traits often tweaked to exacting perfection by the scientists.

However, just before they deemed the project a complete success, operatives of the League of Free Men infiltrated the facility and sabotaged the work of their enemies. A formula designed to randomly manipulate the compounds and a software virus were both introduced into the facility's systems. Although one of the operatives was captured, tortured, and later executed, the damage inflicted upon the facility was irreversible. The compound and process of instilling controlled mutations was now chaotic and uncontrollable. Mutations were now random and often debilitating. New test

subjects died or were horribly disfigured, mentally stunted, and wildly erratic. The facility and its secret testing was eventually abandoned.

Antagonists

The facility was left guarded by several robotic units that, amazingly, still patrol the small bunker. Hidden solar crystals embedded in the rock face of the Appalachian Mountains continue to provide limited energy to the small facility below. The robotic units were programmed to destroy intruders but with their limited energy supply, only periodically patrol the deserted halls and rooms of the abandoned laboratory.

Additionally, a group of Archivists, a Cryptic Alliance bent on securing artifacts for worship, have been searching for the facility in the Appalachian foothills and mountains for years. They will either move to stop any competition or shadow the characters, hoping they lead their group to the facility.

Adventure Start

The secret facility can be found in two ways: the characters can stumble upon the bunker door by chance after days or weeks of searching, or they can find that the strange glitter of solar crystals in the rock walls of the mountains are just above the hidden entrance. If the solar crystals are examined, the characters will learn that they are not naturally formed and are an ancient, energy-capturing, engineered silica embedded in the mountains. Removing the crystals will lead to the discovery of wires and panels in the rock, all leading in the general direction of where the single bunker entrance may be found.

Note that the two-page map that details the facility locations is found on pages 16-17.

Area 1: Entrance

At one point in time, a narrow path between rows of thick trees led to the door. However, the hot sun and lack of rain has long since killed any vegetation in the area. Dead moss covers the steel door in the rock wall, making it indiscernible from its surroundings. A control pad is cleverly hidden under a flap of hanging moss. A search and intelligence check will reveal that the moss is fake.

Detect Fake Moss:

Roll under Intelligence

The control pad has been damaged by time and the elements. A rewiring of its internal components may open the door. Use one of the electrical door flow charts on page 24 to open the portal. Once opened, the smell of decay and stale air bursts through the opening. The tunnel beyond the door is unlit. Broken tiles and exposed wires can be seen within the tunnel entrance where the outdoor light illuminates beyond the threshold.

Note that this is an excellent point for an Archivist attack. Reveling in the characters' success of opening the door to the lost facility, the crazed group will waste little time trying to dispatch their adversaries. They will not yield or surrender, nor will they give quarter or mercy. They are hell-bent on securing the priceless technology within the bunker at any cost.

Archivists (6): HP: 40, 39, 37, 35, 34, 31; AC: 7; Move: 9; AT: massmind, reflection, radiated eyes, pyrokinesis; MU: teleportation; 2 artifacts, 2 treasures.

Area 2: Energized Gate

Characters will need a light source to reach this end of the tunnel. Since the robotic units within the facility cannot enter the tunnel from the internal areas, they have not powered of any devices, lights and systems found within the abandoned

hallway. However, after characters turn the corner northward, they should see small electrical currents running through the metal of the wire gate that blocks entry into the large room beyond.

Detect Electricity Current in Gate:

Roll under Intelligence

(grasping the bars while electrified results in taking 1d8 damage per five seconds of continuous contact)

Two control pads are found here, one on each side of the gate. The control pad on the south side of the gate is inoperable but the pad beyond in Area 3 appears to be in working order. Characters can open the gate in three ways: They can reroute power using exposed wires in the walls and ceiling of the tunnel to reactivate the southern control pad (requires an artifact use check with flowchart on page 24), they can pass a Dexterity check to reach through the bars to access the panel on the north side of the gate (roll under Dexterity and use the flowchart on page 24), or they can splash water on the rusting bars to trigger a short-circuit. This will make them bendable with a successful Physical Strength check (roll under half Physical Strength). Note that robotic units will be notified that the gate has short circuited.

Additionally, a **household robotoid** doubling as a security unit patrols Areas 3 and 4 every six hours. There is a one in six chance that the robotic unit may begin its patrol while the characters are trying to open the gate.

Household Robotoid (1): HP: 20; AC: 4; Move: 5; AT: 2 tentacles (1d6 damage).



Area 3: Main Laboratory

Dozens of tables, chairs and broken computer terminals are found in four short lines spanning the room. Robots have tried to keep the room orderly by righting fallen furniture or replacing deteriorating pieces with less deteriorated pieces. It appears as if someone or something has been trying to keep the room organized, even after years of abandonment. Closer inspection will reveal the tell-tale tread marks of robotic units weaving between desks, chairs and cabinets.

*Detect Tread Marks in the Dust:
Roll under Intelligence*

Additionally, a careful search of the area will uncover hundreds of moldy file folders and disintegrating papers. If enough precaution is taken, a few of the papers will be just barely legible. The words "MuTech Test Facility" will be found on several pages. One extremely lucky character may find a page in a binder that details some of the back story of the facility's end days from the perspective of one of the scientists (GM discretion).

The patrolling robotic unit will exit Area 5 and enter this area every six hours (see Area 2).

The door to Area 6 is electrically locked. It can be opened using the computers in the control room (Area 4) or by the control pads on either side of the door (use flowchart on page 24).

Area 4: Control Room

Rusty metal stairs lead up to a glass-covered door and control room. Moss and mold cover the inside of the glass and the smell of wet stone and earth can be detected through a single crack in the lower portion of the door glass. Ten hit points of damage will shatter the glass, revealing a wet room filled with computer equipment. Water trickles through a crack in the far wall, pooling along the floor in half

the room. The moss gives off a pleasant aroma, possibly affecting characters with a strong urge to eat it. Unfortunately, the moss is toxic (Poison, Intensity 9) and will kill all but the heartiest of characters.

*Resist Urge to Eat Moss:
Roll under Constitution*

Investigating characters will find that the equipment in this room has been powered down but is still operable with an artifact use check (use flowcharts on page 23). Once the systems are powered on, characters can return lights to the facility, open the door between Areas 3 and 6, and turn off the robotic unit in Area 5.

However, if the characters try to power up the systems while standing in the pooling water in half the room, there is a 1 in 6 chance they will be electrified (taking 2d8 damage). When the power is restored to this part of the facility, inquisitive robotic units from Areas 5 and 6 will arrive to investigate.

A locked cabinet near the door to the room contains a **Stun Ray** with **three depleted Solar Cells**. A charging station in one of the computer units charges solar cells (using the crystal silica atop the mountain). If more than ten cells are charged in an hour, the systems will report low power and automatically shut down the control room. It will take twelve hours to restart everything in the room.



Area 5: Closet

Old file cabinets, tape drives and storage arrays have fallen into ruin within this small room. A robotic charging station on one wall is used by the unit most often found here (unless already found outside the closet). Tools for plumbing, electrical and computer repair are piled in one corner of the dark area. A **tear gas grenade** is oddly mixed in with the pile of tools—any character rummaging through the pile has a 1 in 10 chance of accidentally activating the grenade.

Area 6: Testing Center

Scientists overseeing the testing and treatment of mutated subjects once worked in this spacious lab. Tall counters, stools and comfortable chairs are scattered about the area. Two charging stations on the short wall near the room entrance (from Area 3) keep security robots moderately charged. Two keyed doors (to Areas 9 and 12) are locked, only opened by **keys now held by the robotic units**. (Note that either key opens Area 9 but both keys are needed to open the pair of doors leading to Area 12.)

Faint floor stains are strangely reminiscent of blood or bodily fluids. Similar stains are found on walls, often resembling handprints or facial patterns. A recording device on one of the tall counters is still somewhat operable. If used, it will play back the last moments of the sabotaged systems when test subjects emerged from their rooms, hideously transformed and feral. Screams of fleeing scientists and sounds of energy weapons firing drown out the panicked voice of a scientist who desperately tries to record the horrible change in the facility's last days. The recording works once before disintegrating. An **access key card** is taped to the bottom of the unit—this is one of the two access cards left in the facility that will open Area 13 (the other in Area 10).

A hidden niche under one of the tall counters can be found, revealing a case of medical vials and needles. **Four doses of Accelerata** and **two doses of Pain Reducer** are found within the small case.

Security Robotoid (2): HP: 72, 72; AC: 2; Move: 10; AT: 2 paralysis rods (1d4 damage + temporary paralysis), slug projector with 10 clips of slugs, grenade launcher (50m range) with 4 sleep and 5 tear gas grenades.

Area 7: Test Subject, Room 1

Although closed, the door to this room can be pushed open with relative ease. The top of the door has a strange bow to it, rendering it impossible to close.

A bed, flipped onto its side, a broken chair and shredded clothing are strewn about the deserted room. Four hundred and fifty one tallies are marked on the back wall in a neat, organized pattern. A small, unfinished hole in the floor under the pile of clothes appears to have been dug long ago.

Area 8: Test Subject, Room 2

The door to this room is wedged closed from the outside—pieces of broken furniture and scraps of metal are jammed between the door and frame, preventing it from being opened from within. Removing the scrap metal and wood frees the door.

Three humanoid skeletons are found in the room. One decayed form, close to the door with its bony fingers stuck in a small opening in the door frame, lies to the side. Two skeletons are huddled together in the back of the small room, their upper limbs intertwined. A careful search of the bones will reveal that one of the skeletons has three arms, and the other is missing the lower half of its left leg. Additionally, each of the three skeletons have dozens of deep knife cuts in their skulls, forearms and ribs.

Area 9: Mess Hall

The door here can only be opened by one of the key cards held by the robotic units in Area 8.

Four tables and twelve stools remain in their last, neatly placed position before the facility was abandoned. Characters will quickly realize by the thick layer of dust and undisturbed furniture that the robotic units have never entered the area. Cups, plates and cutlery are stacked in a bin near the tables and dozens of cans and boxes of spoiled food are organized in a wall cabinet.

Two broken computer stations on desks stand opposite the entry. Faded pictures of spouses and children, now centuries gone, hang from the wall between the computers. A strong odor creeps from under the door to Area 11, and the light door to Area 10 is partially opened.

A metal box on a small reading chair nearby contains a **voluminous, scientific tome**. Any who read the book, entitled "A History of Computer Equipment from 2199 to Present" lists and details every type, make and design of computers created between 2199 and 2251. Additionally, it highlights methods of access, repair and construction of units. Readers will gain a *permanent* bonus of one (subtract one) to all computer artifact use checks after a full, 150 hour read of the tome. It has been preserved in its airtight box for many years but will begin to rapidly age once exposed to the toxic air of present day. The book will fully deteriorate in two weeks.

Area 10: Scientist Quarters

Eight bunks, stacked in twos, fill the small room. Bed sheets and personal effects of the scientists that once worked and lived here have nearly fully disintegrated. A careful search of the room will uncover a skeletal figure under one of the bunks, curled up in a ball. A large

black stain on its right collar bone and ribs hint to an energy weapon attack. Remnants of a lab coat are still present surrounding the prone figure. An **access key card** is found in one of the coat pockets—this provides access to Area 13.

Area 11: Lavatory

Immediately upon opening the door to this area, characters will be overwhelmed with a sickening stench of rot. They will find a **strange, dark plant** growing amidst the toilets and shower stall. Slowly pulsing with life, the plant waits for prey to get close (1 meter) before violent shaking, shooting 3d6 large thorns in all directions. If the plant senses dying or dead prey, it releases long tendrils to fetch the body, drawing it close for consumption. After its attack, it must wait one to two months to regrow its thorns. Until then, it is defenseless and will not search for prey to attack.

Strange Plant (1): HP: 10; AC: 10; Move: 0; AT: 1 thorn burst (3d6 thorns hitting all targets within the room, split up evenly by targets, each thorn deals 1d4 damage).

Area 12: Experimental Lab

Characters must use both the access cards found with the robotic units in Area 6 to open the doors to this large chamber. Control pads may be rewired to open the doors but is considered a very challenging task.

A massive, empty glass tank stands upon a raised platform in the middle of the room. Dormant computer stations surround the tank on four sides. Scientists once performed tests and research on mutated individuals within the tank as they were subjected to new or repeated compounds and formulas. There are two empty weapon racks on the wall opposite the entrance. Rippling energy spans an open archway on the west wall. Characters that touch or attempt to pass through the energy take 4d8 damage and are knocked back into the room 1d4 meters.

The computer systems will remain dormant until powered on by the control room (Area 13).

A hidden panel behind the weapon rack holds several weapon cells: **one each of Chemical, Solar, Hydrogen, Atomic**—all fully charged.

Area 13: Control Room

A special access card is needed to power down the electrical barrier to this room (cards are found in Areas 6 and 10). The room contains several independently powered computer systems that tap energy from other facility systems to power themselves up. After passing a difficult artifact check (use flowcharts on page 23), characters will discover that the systems in this room were once used to mutate test subjects in a controlled manner. However, they may not realize (unless the details are discovered in Area 3 or 6) that the system code and compounds were sabotaged. Systems will indicate that flawed mutations can be removed and new, super-human mutations can be added with ease. Characters may get the bright idea to give it a try.

The systems will first fill the tank with a strange fluid (mixture of spring water from below and several foreign chemical compounds) then provide directions on how to prepare test subjects for mutation, including full immersion in the tank. A menu of mutations is shown, and the character may select one to add or remove as desired (GMs can use the physical mutation chart on page 9 of GW rulebook, for example). Unfortunately, the system will instead add (1-3 on 1d6) or remove (4-6 on 1d6) one random mutation. GMs should use their mutation chart of choice, randomly rolling the change. Note that the GM may choose to have the changes occur within the system-specified timeframe (3-4 hours) or within 12-24 hours of exiting the tank. Of course, having the mutation appear or disappear

long after the characters leave the facility makes the adventure much more interesting!

If at least 24 hours are spent in study and review of the systems, characters will likely find the sabotaged code and chemicals and determine that the procedure no longer works as it once did.

Adventure Conclusion

Although not rich with technology, the MuTech Test Facility offers explorers a few physical rewards and potential mutations for those brave enough to endure the chaos of the sabotaged systems. Surviving Archivists will continue to look for the facility, eventually discovering its secrets and even misusing its technology.

An additional adventure in this fanzine details a secret hideout of Archivist mole men. It can be adapted to be an extension of this adventure. "The Hand", found on page 19, can be the secret lair of the Archivists in the area.



The Hunted, Chapter One

Prologue

After being chased and tracked for several days, Whyla (a young, pure-strain human female) and her faithful dog, Arnold, have found themselves trapped in the remnants of an old building in an exposed area. The partially destroyed building barely provides any cover for the pair of wanderers. The nearest hill, their next best chance at finding cover, is a half-mile away—a run too dangerous to venture with hunters on their tail.

The rumble of the ancient, two-wheeled vehicles causes the ground to shudder below the huddled wanderers. Six motorbikes have finally caught up to Whyla and her dog Arnold after days of relentless pursuit. Peeking through a hole in the decaying block wall, Whyla can see the wasteland raiders slowing down as they search for her tracks.

Opening her pack, she takes a quick inventory of her remaining gear. She has two fragmentation grenades, a Vibro Dagger and an ancient pistol with a single bullet left in its chamber. She chuckles to herself, knowing her position is grim. Patting Arnold on his steel-reinforced head, she decides to take her final stand here. Her only hope is draw them close and take out as many as she can with a grenade.

While the vicious bikers discuss the tracks they've found, the young girl carefully slides her emptied backpack through a hole in the wall, tucking it against the opposite side. If she can get the raiders to spot the dark green bag next to the wall, she may be able to draw them to her position. The old green bag, likely some artifact of the pre-Black Years military, will catch the raiders' eyes as they search the area. Her hope is that most of them will approach at once, making it easier to wipe

them out with a single, catastrophic explosion.

They take the bait, seeing the green bag from their circling position. Five of the cycles approach, their riders eager to search the bag and hopeful they'll find ancient technology or artifacts. One raider remains at a distance, his eyes searching the area for his prey.

Whyla waits for the raiders to dismount their rusty and pieced-together machines. Their unclean scent can be detected from behind the crumbling stone wall that she's hidden behind. Arnold's ears are up, hearing the guttural language of the raiders, but he makes no noise at all. He only looks to Whyla for her next command. She's trained this dog since his birth, and has been with him through every cybernetic installment surgery. His muscles are tensed as he waits for her command. She can tell he's ready to tear into one of the filthy raiders with his steel jaws.

"Hey. Looks like it's got stuff in it," a deep voice declares. "Maybe we got some food for once."

"Nah, those bulges look like clothes, maybe armor," another gravelly voice utters. "I bet it's just rags."

"Shut up, you two. Let me think," whispers a third voice, hinting at possible intelligence. "Why would this bag be here, out in the open?"

"Maybe it's the girl's, Boss," urges the first voice. "Maybe she dropped it 'cause it was weighing her down."

"Maybe, but I doubt it," declares Boss. "Whatever the reason, let's see what's in it. Open it up, Shank."

Hearing the crunch of boots in the sand, Whyla can tell a large man approaches. By the number of steps she estimates he's moved a few

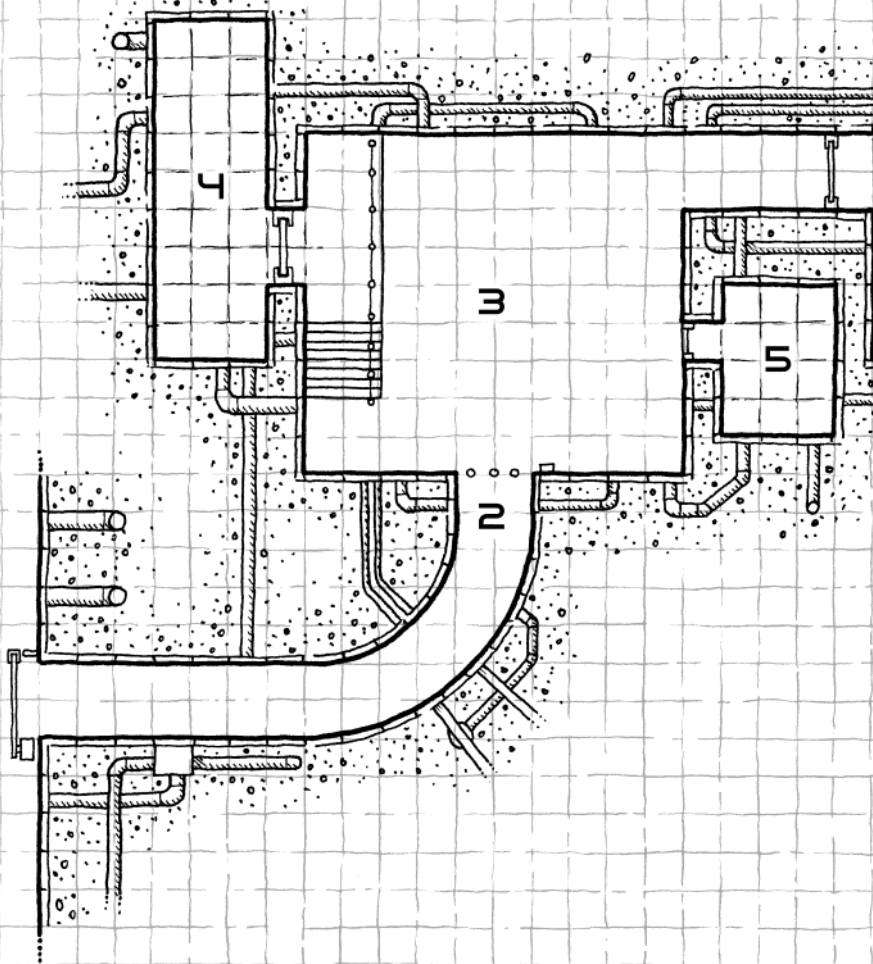

MUTECH TES

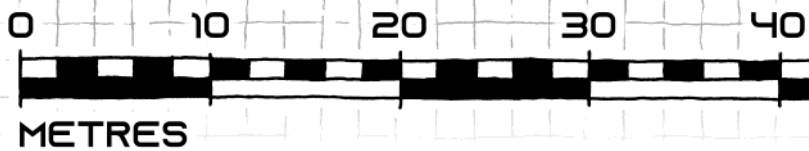

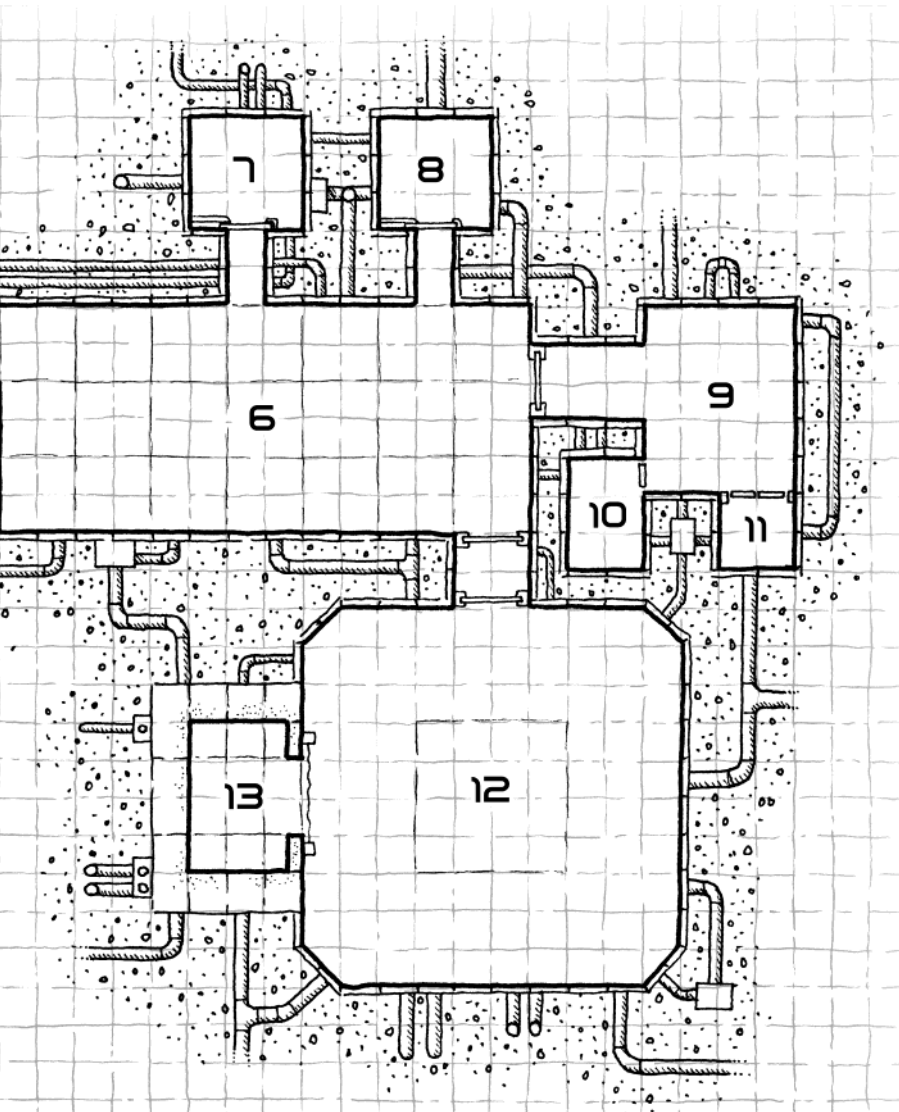

ST FACILITY



meters to get to the bag. The group is likely less than five meters away. This grenade has to count. Shaking her head to let Arnold know he isn't to move from his sitting position, she turns toward the wall. Having found a hole in the bottom of the wall earlier, she has planned to roll the grenade under it and through to the other side, hopefully landing somewhere between the bag and other raiders. She slowly pulls the pin and counts to five in her head, leaving only five more ticks before the fragmentation grenade will explode. Tossing it hard under the wall, she turns and rolls away to one side, grabbing Arnold by his heavy collar.

Whyla hears the loud intake of breath as grenade bounces on the other side of the wall.

"Get down!" screams a startled voice, just before an enormous explosion violently shakes the ground.

As metal fragments tear through the wall dropping chunks of rock and debris on the scavengers' heads, a second and third explosion reverberates in the open space beyond. Whyla, still down covering her head and shielding Arnold from falling bits of rock, is surprised by the additional explosions. She waits a few seconds before getting up to her knees. It's deadly quiet.

The young girl crawls to a newly formed hole in the wall near her protective position. Peeking through the freshly made gap, she sees a horrific scene of carnage and gore beyond. Her grenade has indeed done its job well—several raiders are down and two motorbikes are burning. Leaning down to the ground to see how the nearest raider fared, she sees only chunks of bloody meat and smears of red in the sand. *Looks like the poor bastard got it good.* Scanning the area, she counts five bodies, all in various states of dismemberment and disembowelment. She had counted six bikes the last time she had chanced

a glance at the pursuing raiders. Where's the sixth?

A suggestion of movement from the body farthest from the burning bikes catches Whyla's eye. She now sees that one of the raiders has survived the explosions. He's missing an arm and part of his leg but he's crawling away from the fire, using his good arm to slowly pull himself forward through the bloody and gasoline-covered sand.

Arnold patiently waits for a command, his body shaking with adrenaline. Whyla knows she'll have to release him soon—the dog smells death and needs to investigate the area. Just as she starts raising her hand, she hears the roar of the sixth engine. It's the last raider—he's riding in! A stern look and reassuring hand on the dog's snout calms the young canine. She whispers in his ear, "Just a little longer, Arnie."

Peeking through the wall, she witnesses the raider and his bike pulling up alongside the crawling, disfigured mutie. "Ah, Boss. You look bad," laughs the three-eyed wastelander. "Where ya gonna go all messed up like that?"

The dying raider tries to utter a few words, but the crawling man's mouth just bubbles with air and blood. Reaching up with his stump of an arm, it seems to Whyla like he's asking for help. His former minion just stares down at him with an evil grin. It's at this time that Whyla notices the shiny black barrel of a long rifle on the seated raider's back. Thinking quickly, she removes the ancient pistol from her waistband. She'll use her last bullet on this fool, trading in her old revolver for a long rifle. *One bullet left.* Like her grenade, this has to count.

Next time: Will Whyla succeed in neutralizing the raider threat?

Adventure #2—The Hand

Adventure Background

Outcast molemen with limited speech and a strong desire to worship ancient technology have banded together, forming a fringe faction of Archivists. Eager to advance the cause of their alliance, these molemen have used their heightened abilities and experience to find numerous pieces of technology. Although much of it is useless, there are a few artifacts of value in their strange compound. They have discovered the hand of an ancient statue made of concrete and steel and have used its interior as a defensible and safe lair.

Determined to scour the wasteland in their endless search for lost technology, Archivists will stop at nothing to obtain the treasures they seek. Any who oppose the Archivists in their search are sure to be eliminated.

An adventure for 3-6 characters.

GM Background

A large group of molemen have taken up residence in the hand portion of an abandoned colossal statue—the only section of the large structure that isn't buried in the radiated ground. It is rumored that the molemen Archivists have squirreled away countless pieces of broken and useful technology, and have set up shrine around a working artifact. The rumors are true—a shrine in the upper level of the complex has been erected to a small neutron bomb. The molemen are unaware of its devastating effects but know that it works, worshipping it as a god. They are so dedicated to its power, they are willing to destroy it and themselves rather than have it stolen by non-believers.

The molemen have mercilessly raided villages, tribes and merchant

caravans in the area, killing all who oppose their demands for technology. Characters may witness the aftermath and carnage of these vicious attacks, and either desire to put a stop to it or steal the molemen's tech for themselves.

Adventure Start

A deteriorating concrete hand juts out of the ground, reaching into the air high above the surrounding hills. Although the structure appears to be falling apart, the internal steel beams and wire mesh are keeping it sound. Molemen guards will be on the lookout for intruders, using the higher sections of the hand to watch the surrounding area.

Area 1: Entrance

A locked wooden door prevents unauthorized entry to the compound. The door appears poorly made and can be opened with minimal force.

Unlock Door:

Roll under Half Dexterity

Smash Door:

Roll under Physical Strength

Two moleman guards watch the door from above, using the open space between Areas 10 and 11, and the small windows in Area 15 to maintain sight below. Each moleman scout carries an **ancient .22L caliber rifle with 3d6 rounds of ammunition**.

Ruger .22L semi-automatic rifle, maximum range 100 meters, effective range 50 meters or less, projectile jacketed lead, damage inflicted 3d6.

Area 2: Common Area

The entrance opens up into a common area where several moleman sleep, eat and sort through pieces of technology recently acquired. Molemen will rush characters to push them out of their lair, attacking with knives, clubs and chains.

15



The Hand

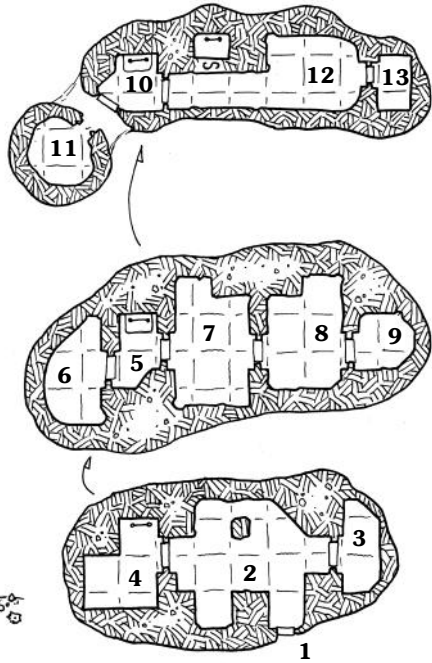

Molemen (2d6): HP: 15 each; AC: 7; AT: crude weapons (1d6 or 1d4); Move: 12; MU: Heightened Touch, Heightened Hearing and Heightened Smell; DEX 13;

Area 3: Refuse Hole

Several small holes in the floor lead to cess-pits below the compound. Characters must resist Intensity 8 Poison to avoid becoming sick here.

Area 4: Closet of Junk

All newly acquired technology is placed in this area to be sorted and catalogued at a later date. For each hour this room is searched, there is a 25% chance that a useful piece of tech is found.

A ladder in the north wall leads to the next level above.

Area 5: Hallway

The ladder from below continues up to the third level (Area 10).

Area 6: Moleman Mates

The leader of the moleman Archivist faction keeps his two mates in this modest room. Each is adorned with metallic chains and rusty parts, arranged and assembled as crude jewelry.

Area 7: Testing Room

Molemen responsible for researching artifacts and pieces of technology of interest work in this quiet room. The molemen researchers will defend their treasures but are lesser fighters than the warriors in the other rooms in this facility (half HP).

There is a 50% chance that characters will find 1d4 valuable artifacts in this area.

Area 8: Broken Parts Room

Pieces of artifacts and broken tech have been placed in this area for later evaluation. Piles of metal, plastic and wood are scattered throughout the area. It is possible to find 1-2 useful items after a four hour search.

Area 9: Chief Archivist

The leader of the faction uses this area for his personal quarters. Surprisingly intelligent and capable of broken speech, Ugabakanta leads his group of molemen in the frantic search for lost tech. He is here 50% of the time—otherwise, he is in Area 12 examining their most recent acquisition.

Moleman Leader, Ugabakanta: HP: 25; AC: 7; AT: Mark V Blaster with two fully charged Hydrogen cells—WC: 14, range: 150/75, damage: 5d6; Move: 12; MU: Heightened Touch, Heightened Hearing and Heightened Smell; DEX 14;

Area 10: Hallway

The ladder on the north wall leads to the upper and lower levels. A moleman scout moves between Area 10 and 11 periodically. The outside door remains locked at all times (similar to main entrance, Area 1).

Area 11: Unfinished Computer

Ugabakanta and his researchers are slowly putting together an ancient computer, using pieces taken in their raids and explorations. The computer is not quite half finished and is badly constructed—it is unlikely the moleman will get this machine to work without help.

Area 12: Shrine

A **half-sized Neutron Bomb** rests upon a crude pedestal, its infrequently twinkling lights indicating that it is still armed and ready for detonation. Any weapon's fire or grenade explosions in this area may trigger the bomb's detonation. If triggered, it explodes, destroying the compound and 250 meters of surrounding area, leaving a 5 meter crater. All living things within the blast will instantly die unless protected by force fields capable of withstanding 50 HP of damage.

At least eight molemen will be here worshipping their new god. The fanatical Archivists will attempt to

drive intruders from the room, either pushing them down the ladder or outside through Area 10.

A secret door leads to a small room with a ladder to Area 14.

Find Secret Door:

Roll under Half Intelligence

Area 13: Computer Parts

Parts reserved for the unfinished computer in Area 11 are stored here. There is a 25% chance to find 1-2 useful items in the piles in the room.

Area 14: Secret Room

Only two molemen know of this secret room—they store valuable treasure and artifacts here, away from greedy molemen archivists. Three bags of gold coins (**279 gp**), **1d4 artifact weapons**, and **2d4 general artifacts** will be found on small tables, neatly organized and identified.

Parts reserved for the unfinished computer in Area 11 are stored here. There is a 25% chance to find 1-2 useful items in the piles in the room.

Area 15: Lookout Tower

A second scout watches the surrounding wasteland from this tower. He can ring a bell that summons warriors in Area 2 and their leader when intruders approach.

Adventure Conclusion

The molemen will not allow their new treasure to leave the compound, preferring to destroy it and themselves rather than lose it. If the characters can manage to take it, they will have a considerably powerful and valuable artifact in their possession.

Artifact Use (Solution) Flowcharts

Arguably one of the most unique and beloved parts of the first edition Gamma World rulebook was the artifact solution flowcharts. These charts provided a simple yet interesting way for a character to solve how to use an item in the game. For the player, this meant some die rolling, often dozens of rolls until a final solution was determined. Sometimes, rolling the dice took a while, slowing the game down (some of the complex charts are huge). As an alternative, here are a few simpler charts.

Using Ancient Items

These next four charts are meant for revealing an item's properties and usage. Use the Intelligence "bonus" as indicated in the rulebook, and roll a 1d10.

Simple Item Operation

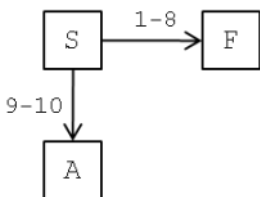

S: Start.
A: Failure to understand use.
F: Item operation understood.

Unusual Item Operation

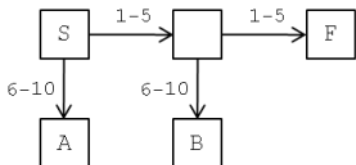

S: Start.
A: Failure to understand use.
B: May try later (20-INT hours).
F: Item operation understood.

Challenging Item Operation

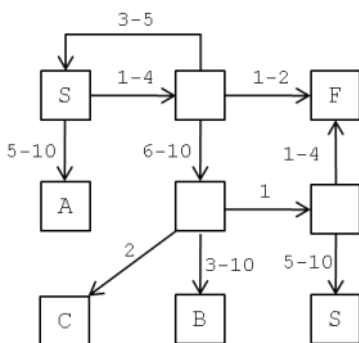

S: Start.
A: Failure to understand use.
B: Item broken, unusable.
C: May try later (30-INT hours).
F: Item operation understood.

Complex Item Operation

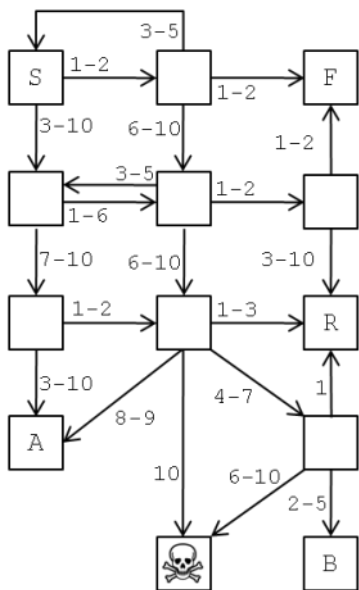

S: Start.
R: Return to Start (start over).
A: Failure to understand use.
B: Item broken, unusable.
☠: Item explodes, injury likely.
F: Item operation understood.

Opening Ancient Doors

Different types of doors present characters with different types of challenges. Although characters can use a die roll to open doors, a flowchart works just as well. Doors are separated into mechanical and electrical groups.

Mechanical Door

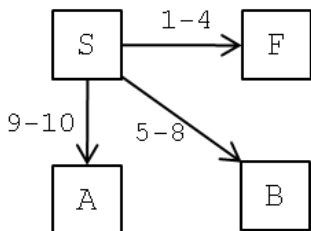

- S: Start.
 A: Failure to open door.
 B: Door opened, broken.
 F: Door opened, reusable.

Locked Mechanical Door

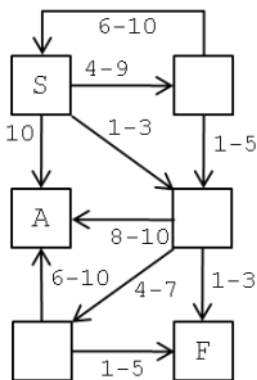

- S: Start.
 A: Failure to open door.
 B: Door opened, broken.
 F: Door opened, reusable.

Physical Strength “bonuses” may be substituted for Intelligence “bonuses” on die rolls when characters are physically forcing open mechanical doors.

Electrical Door

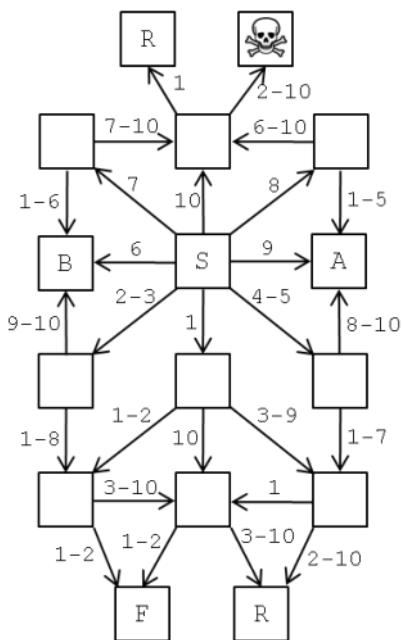

- S: Start.
 R: Return to start (start over)
 A: Failure to open door.
 B: Door opened, broken.
 Skull: Door explodes, injury likely.
 F: Door opened, reusable.

Electric doors often require pass codes or access keycards, and are often reinforced to prevent heavy physical damage and to resist forced entry. Physical Strength “bonuses” should not be allowed when trying to open an electrical secured door.

Similar keycards may help in opening electrical doors—subtract 1 from rolls when using a similar type keycard. Exact cards may be more beneficial—subtract 2 from rolls when using a keycard that is an exact match.

Adventure #3—Dark Knights

Adventure Background

Since their formation, the Knights of Genetic Purity have made it their mission to hunt and exterminate mutated humans, hoping to cleanse the planet of tainted bloodlines and genetic impurities. Clashes between pure strain human Knights and mutants are legendary but either side rarely prevails for long. Groups of KGP move frequently, constantly on the lookout for new communities of mutated humanoids to eradicate. Most small villages or traveling groups of mutants move on when they find that merciless Knights have moved into the area. However, one community refuses to move, hoping that hired muscle can wipe out the newly arrived KGP before they attack their established and comfortable village.

A Challenging Adventure for 3-5 characters.

GM Background

The village of Galax has been hidden from travelers for many years. Nestled in the former Appalachian Mountains, the undisturbed community's elevation makes it difficult for any but locals to find the walled village of 50 residents. A clean water source and moderately successful farming has given the local families hope in an otherwise hopeless world. Diversity within the community is rich—nearly every resident suffers from one mutation or another, but a surprisingly accepting group of leaders and family elders have made Galax a relatively safe place.

Coal Mine

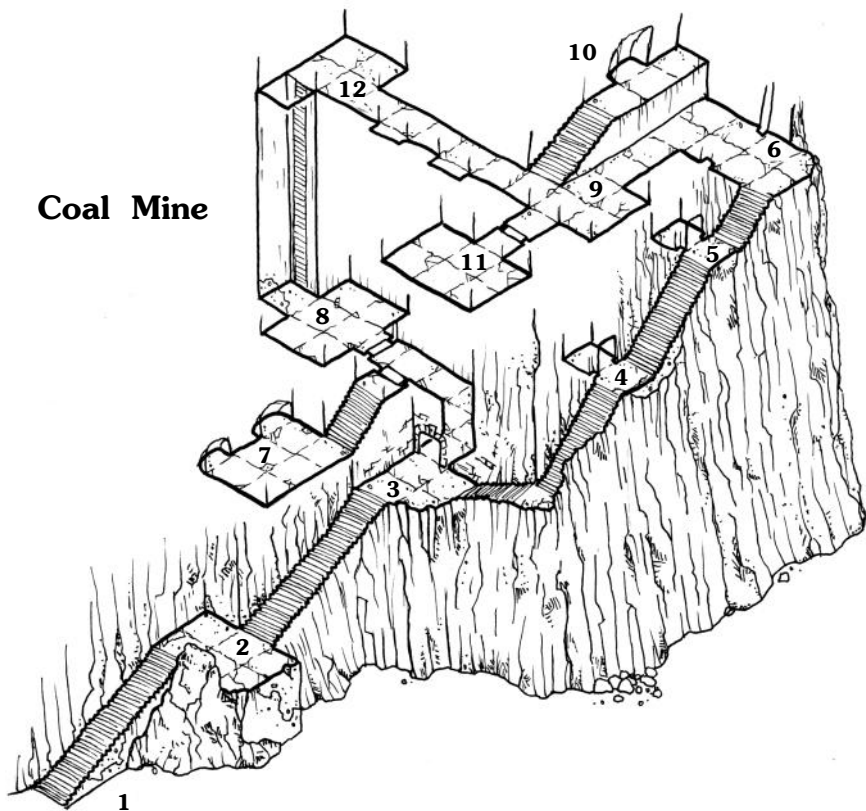

A group of strangely-dressed humans have overtaken an old mine in a nearby mountain. Distinctive armor markings and weaponry identified them as Knights of Genetic Purity, leaving little doubt of their ultimate intentions. Before long, Galax scouts notified their elders, resulting in the decision to eliminate the newcomers before they could attack the community. Lacking the skill to combat the KGP themselves, a bounty of 500 gp, along with two artifact weapons, has been offered to any who can remove the threat from the area.

Galax

The details of the small community are not listed here—the GM is encouraged to create a small, walled village with a dozen or more structures to serve the need of this adventure. The GM will also have to work into the adventure how the characters find Galax and agree to the bounty. Once characters agree to the job, have them start at Area 1, the back entrance to an old mine.

Area 1: Entrance

Only the back entrance to the coal mine still remains, with most of mine collapsed or impassable. The mine was restarted during the Shadow Years when coal returned as a primary energy source after the fall of power grids and energy networks. The back entrance was used mainly by miners who worked the farthest end of the large mine.

The open entry into the mine is unguarded, Steep stone stairs lead up into the mountain and several open areas once used by miners between shifts or on break.

Area 2: Changing Room

Miners once used this area to change clothing, adding soot-covered overalls and safety equipment when entering the mine or donning regular clothing when exiting. Old, rusted lockers line two of the walls and overturned and broken stools

are scattered throughout the room. Deteriorating clothing and damaged helmets are found in several lockers. Two dry shower stalls haven't seen water in decades.

Two Knights of Genetic Purity are on guard duty here. Having just moved into the mine, the guards aren't expecting intruders and may be surprised.

Knights (2): HP: 75 each; AC 3 (plastic armor); AT: Laser Pistol, WC: 13 (5d6 damage), 3 Hydrogen energy cells, 10 shots each; sword (1d8) and dagger(1d4); Move: 9; DEX 13

Area 3: Report Station 1

When entering or exiting the mine, miners were required to check in with administrators in this office. A rust-spotted desk with missing drawers lies on its side in the center of the room. Two file cabinets with stained and illegible paperwork have been pushed to one of the walls of the area. A search of the file cabinets should reveal a hidden box of **slug thrower ammunition** (50 rounds, .38 caliber, 2d6 damage each).

Area 4: Supply Closet

A stop along the steep staircase allowed miners to take or leave mining gear as needed. Ancient shovels, pickaxes and crowbars have been haphazardly stacked in this open closet, most too rusty or rotted to be of any use now.

The Knights have rigged the landing with a laser tripwire. A small, nearly invisible beam of light spans the narrow hallway, attached to a device that sounds a loud alarm when disturbed. The alarm rings for one full minute before resetting.

Find Tripwire:

*Roll under Intelligence
Accidentally Activate Trap:*

*Roll **Over** Half Dexterity*

After hearing the alarm, Knights from Areas 8 and 12 will converge on this location from both sides in 2d6 rounds. If a guard is in Area 5, he will try to slow down the characters to allow other Knights time to arrive.

Area 5: Supply Closet

An empty supply closet is now used by a lone KGP sentry (50% chance to be present). Armed with a Mark VII Blaster Rifle, the guard will use his superior position to pin down characters in the lower section of the stairwell.

Knight Sentry: HP: 50; AC 3 (plastic armor); AT: Mark VII Blaster Rifle, WC: 14 (8d6 damage), 6 Hydrogen energy cells, 5 shots per pair; sword (1d8) and dagger(1d4); Move: 9; DEX 14

Area 6: Report Station 2

A final clearance and supply check of miners entering or exiting the mine was performed in this large room. Years after the Great War, an entrance to the rest of the mine collapsed, preventing entry to the tunnels and shafts beyond. Rubble from the cave-in covers much of the floor, requiring characters to carefully step around and through the debris.

A Unipede has recently made its home in the collapsed portion of the tunnel beyond this area. Excessive noise in this area will bring it in search of prey.

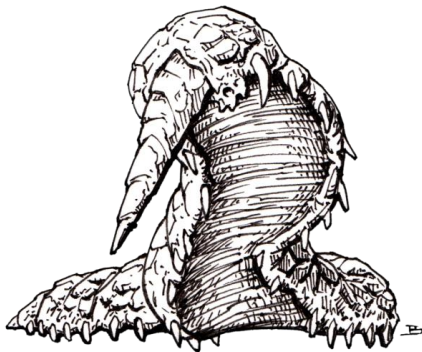

Unipede: HP: 75; AC 3 (thick skin and stone covering); AT: horn attack, WC: 3 (2d12 damage), or Ultrasonic burst (1-d6 damage); Move: 4/12; DEX 12

Area 7: Testing Room

Samples removed from the mines were occasionally tested for purity in this small laboratory. Specialists reviewed sample data to ensure that toxins and impurities were not present in the coal removed from the mine. Old scientific equipment is still present in the large room, mostly left in their original positions on steel tables and wooden desks. A search of the room should reveal a few pieces of usable equipment and 1-2 artifacts in working order. There is a 25% chance that a Knight will be found here, rummaging through the old equipment.

Area 8: Testing Room

An old coal mine office has now been cleared to make room for makeshift housing. Ten cots and a few footlockers have been set up for the Knights in the room. There is a 50% chance that 1d4 Knights will be here, either resting or eating. Each is armed with sword and dagger, and wears plastic armor (50% chance they are not wearing their armor when surprised).

Knights (1d4): HP: 75 each; AC 3 (plastic armor); AT: sword (1d8) and dagger(1d4); Move: 9; DEX 12

A search of the room will uncover 1d4 daggers, 1d6 swords and a suit of new plastic armor. **25 gp** and a **dose of Accelera** will be found in one of the footlockers.

Area 9: Paymaster General

Administering payment to coal miners, the Paymaster General's office was a common destination for workers as they finished their work week. Several desks and tables have been moved to the sides of the room to make travel through its center easier. A hidden wall safe holds the last payments of miners

that never returned to work (**750 gp** and dozens of 'promise' notes, a guarantee for future payment).

Find Wall Safe:

Roll under Intelligence

Area 10: Latrine

The Knights have begun to use the old coal miner latrine. They are not keen on cleanliness.

Area 11: Foreman's Office

Shift foremen at this end of the mine used this area as their office, filling out injury reports, worker shift attendance and other administrative duties. Paper logs have mostly been destroyed by time and the dampness of the mine. However, several entries for injuries and attendance may be read in the few remaining pages.

A locked drawer in a small desk still holds an old revolver, its six chambers filled with ammunition. The **Smith & Wesson .38 caliber revolver** is in dire need of cleaning before use. Using it without proper maintenance is likely to cause a serious malfunction and backfire, injuring the user for 4d6 damage.

Smith & Wesson, .38 caliber revolver. Six round capacity. 3d6 damage per bullet. Requires an artifact use check to operate and maintain.

Unlock Drawer:

Roll under Intelligence

Break Open Drawer

Roll under Physical Strength

Area 12: Emergency Exit

The elite members of the KGP use this area as their quarters. Six bunks—one for the leader and five for specialists—line the outer walls of the room. Three of the specialists can be found in areas 2 and 5, leaving two here or roaming about the complex. The KGP leader is most often found here (1 in 1d10 chance that he is elsewhere).

Portable computer equipment has been set up on a table, used to scan the area for radioactive material and life signs within a few miles. The members of the group have been using the equipment to search for possible mutants to hunt.

Knights (2): HP: 75 each; AC 3 (plastic armor); AT: Laser Pistol, WC: 13 (5d6 damage), 3 Hydrogen energy cells, 10 shots each; sword (1d8) and dagger(1d4); Move: 9; DEX 13

Knight Leader: HP: 100; AC 3 (plastic armor); AT: Mark VII Blaster Rifle, WC: 14 (8d6 damage), 6 Hydrogen energy cells, 5 shots per pair; sword (1d8) and dagger(1d4); Move: 9; DEX 15

Several boxes of ammunition and gold are piled to one side of the small room. Characters should find **500 gp, 2d4 Chemical cells, 3d6 Hydrogen cells, 1d4 Atomic cells, 2d6 Fragmentation grenades and 3d100 slug thrower rounds (.38 caliber)**. A first aid kit under the leader's bunk holds **1d4 Accelera doses, 1d4 Sustenance doses** and **1 Cur-in dose**.

Several files in the computer equipment will detail the locations of several other KGP facilities within 100 miles. Additionally, computer records will show over two-hundred confirmed mutant kills by this group alone.

Adventure Conclusion

The elimination of the Knights of Genetic Purity has rescued the villagers of Galax from certain doom. Saving the mutated villagers from the marauding Knights will likely earn the characters a short-term stay in the village, as well as a base of operations in the area.

Note that the villagers have limited access to technology—choose two low-level artifacts for the reward.

Information You Can Use

Do you like fanzines and fantasy RPGs? Check out *Back to BasiX*, another fanzine from ThrowiGames, that celebrates B/X Dungeons & Dragons. Released quarterly, found at Goodman Games and DriveThruRPG.

A new Gamma World adventure from ThrowiGames will be ready for gamers this year—an exclusive North Texas RPG adventure will be ready at the con and at DriveThruRPG in June!

Mutant Future Character Generator

www.mfchargen.com



YOUR HOME FOR THE APOCALYPSE!



www.podcastatgroundzero.com

DriveThruRPG.com has two post-apocalyptic PDF adventures from ThrowiGames for sale! Search 'ThrowiGames' at their site to find **'Into the Wreckage'** and **'A Dish That Serves No One'**, priced at \$2.50 and \$3.50 respectively.



Other ThrowiGames Products

ThrowiGames produces a full line of fantasy and science-fantasy role-playing game products. We specialize in inexpensive, digest-sized products for old-school games. Most products are available digitally through DriveThruRPG.

Digital Products Currently Available from ThrowiGames

Name	System *	Price **	Details
Into the Wreckage	1E GW	\$2.50	Adventure, 36 pages
A Dish That Serves No One	1E GW	\$3.50	Adventure, 30 pages
Scavenge the Sands	SRS	\$1.50	Adventure, 28 pages
2259 Earth!	SF-SN	\$1.50	Setting, 30 pages
Gamma Zine #1	1E GW	\$5.00	Fanzine, 28 pages
Back to BasiX #1—#8	B/X	varies	Fanzine, various lengths
Merchants and Markets	F-SN	\$7.50	Supplement, 124 pages
Off the Beaten Path: Forest Excursions	F-SN S&W	\$5.00	Adventures, 32 pages
Off the Beaten Path: Desert Excursions	F-SN S&W	\$6.00	Adventures, 32 pages
Off the Beaten Path: Mountain Excursions	F-SN S&W	\$6.00	Adventures, 32 pages
Crypt of the Dog Witch	B/X	\$1.00	Adventure, 13 pages
Under Tenkar's Tavern	S&W	PWYW	Adventure, 10 pages
Full Moon Ransom	S&W	\$2.50	Adventure, 17 pages
In Defense of Thuil	Varies	\$2.50	Adventure, 20 pages
Island of Blight	Varies	\$5.00	Adventure, 28 pages
Crypt of Mandazed	S&W	\$1.50	Adventure, 12 pages
Mysteries in Mannath	S&W	\$2.50	Adventures, 52 pages

* SF-SN = science-fantasy, system neutral; F-SN = fantasy, system neutral; S&W = Swords & Wizardry (Frog God Games); SRS = Simple Roleplaying System (TG);
 ** Current prices at the time of fanzine printing, subject to change without notice.

Digital Products Coming Soon from ThrowiGames

Name	System	Price	Details
Batteries Low, Getting Dark	1E GW	TBD	Adventure
Gamma Zine #2	1E GW	\$5.00	Fanzine
The Evolutionary Mishap	TMNT	TBD	Adventure
Operation: Window Dressing	Top Secret	TBD	Adventure
Back to BasiX #9	B/X	\$6.00	Fanzine, June

Back to BasiX

The following text is the property of Wizards of the Coast, Inc. and is Copyright 2000 Wizards of the Coast, Inc ("Wizards"). All Rights Reserved.

1. Definitions: (a) "Contributors" means the copyright and/or trademark owners who have contributed Open Game Content; (b) "Derivative Material" means copyrighted material including derivative works and translations (including into other computer languages), potation, modification, correction, addition, extension, upgrade, improvement, compilation, abridgment or other form in which an existing work may be recast, transformed or adapted; (c) "Distribute" means to reproduce, license, rent, lease, sell, broadcast, publicly display, transmit or otherwise distribute; (d) "Open Game Content" means the game mechanic and includes the methods, procedures, processes and routines to the extent such content does not embody the Product Identity and is an enhancement over the prior art and any additional content clearly identified as Open Game Content by the Contributor, and means any work covered by this License, including translations and derivative works under copyright law, but specifically excludes Product Identity. (e) "Product Identity" means product and product line names, logos and identifying marks including trade dress; artifacts; creatures characters; stories, storylines, plots, thematic elements, dialogue, incidents, language, artwork, symbols, designs, depictions, likenesses, formats, poses, concepts, themes and graphic, photographic and other visual or audio representations; names and descriptions of characters, spells, enchantments, personalities, teams, personas, likenesses and special abilities; places, locations, environments, creatures, equipment, magical or supernatural abilities or effects, logos, symbols, or graphic designs; and any other trademark or registered trademark clearly identified as Product Identity by the owner of the Product Identity, and which specifically excludes the Open Game Content; (f) "Trademark" means the logos, names, mark, sign, motto, designs that are used by a Contributor to identify itself or its products or the associated products contributed to the Open Game License by the Contributor (g) "Use", "Used" or "Using" means to use, Distribute, copy, edit, format, modify, translate and otherwise create Derivative Material of Open Game Content. (h) "You" or "Your" means the licensee in terms of this agreement.
2. The License: This License applies to any Open Game Content that contains a notice indicating that the Open Game Content may only be Used under and in terms of this License. You must affix such a notice to any Open Game Content that you Use. No terms may be added to or subtracted from this License except as described by the License itself. No other terms or conditions may be applied to any Open Game Content distributed using this License.
3. Offer and Acceptance: By Using the Open Game Content You indicate Your acceptance of the terms of this License.
4. Grant and Consideration: In consideration for agreeing to use this License, the Contributors grant You a perpetual, worldwide, royalty-free, non-exclusive license with the exact terms of this License to Use, the Open Game Content.
5. Representation of Authority to Contribute: If You are contributing original material as Open Game Content, You represent that Your Contributions are Your original creation and/or You have sufficient rights to grant the rights conveyed by this License.
6. Notice of License Copyright: You must update the COPYRIGHT NOTICE portion of this License to include the exact text of the COPYRIGHT NOTICE of any Open Game Content You are copying, modifying or distributing, and You must add the title, the copyright date, and the copyright holder's name to the COPYRIGHT NOTICE of any original Open Game Content You Distribute.
7. Use of Product Identity: You agree not to Use any Product Identity, including as an indication as to compatibility, except as expressly licensed in another, independent Agreement with the owner of each element of that Product Identity. You agree not to indicate compatibility or co-adaptability with any Trademark or Registered Trademark in conjunction with a work containing Open Game Content except as expressly licensed in another, independent Agreement with the owner of such Trademark or Registered Trademark. The use of any Product Identity in Open Game Content does not constitute a challenge to the ownership of that Product Identity. The owner of any Product Identity used in Open Game Content shall retain all rights, title and interest in and to that Product Identity.
8. Identification: If you distribute Open Game Content You must clearly indicate which portions of the work that you are distributing are Open Game Content.
9. Updating the License: Wizards or its designated Agents may publish updated versions of this License. You may use any authorized version of this License to copy, modify and distribute any Open Game Content originally distributed under any version of this License.
10. Copy of this License: You MUST include a copy of this License with every copy of the Open Game Content You Distribute.
11. Use of Contributor Credits: You may not market or advertise the Open Game Content using the name of any Contributor unless You have written permission from the Contributor to do so.
12. Inability to Comply: If it is impossible for You to comply with any of the terms of this License with respect to some or all of the Open Game Content due to statute, judicial order, or governmental regulation then You may not Use any Open Game Material so affected.
13. Termination: This License will terminate automatically if You fail to comply with all terms herein and fail to cure such breach within 30 days of becoming aware of the breach. All sublicenses shall survive the termination of this License.
14. Reformation: If any provision of this License is held to be unenforceable, such provision shall be reformed only to the extent necessary to make it enforceable.

15. COPYRIGHT NOTICE

Open Game License v 1.0a Copyright 2000, Wizards of the Coast, Inc.

System Reference Document 5.0 Copyright 2016, Wizards of the Coast, Inc.; Authors Mike Mearls, Jeremy Crawford, Chris Perkins, Rodney Thompson, Peter Lee, James Wyatt, Robert J. Schwalb, Bruce R. Cordell, Chris Sims, and Steve Townshend, based on original material by E. Gary Gygax and Dave Arneson.

END OF LICENSE

GAMMA ZINE

First Apocalyptic Issue!



This First Issue!

Three Adventures
New Mutated Monsters
New Artifacts and Tech
New Tech Flowcharts

Gamma World and *Dungeons & Dragons* are the properties of Wizards of the Coast. Throwi-Games, LLC and Thom Wilson make no claims to IP rights or ownership of said products. The

Gamma Zine fanzine merely celebrates the early science-fantasy and fantasy systems of TSR.



\$5.00

Issue #1