

MAY 233
£3.50

WHITE DWARF

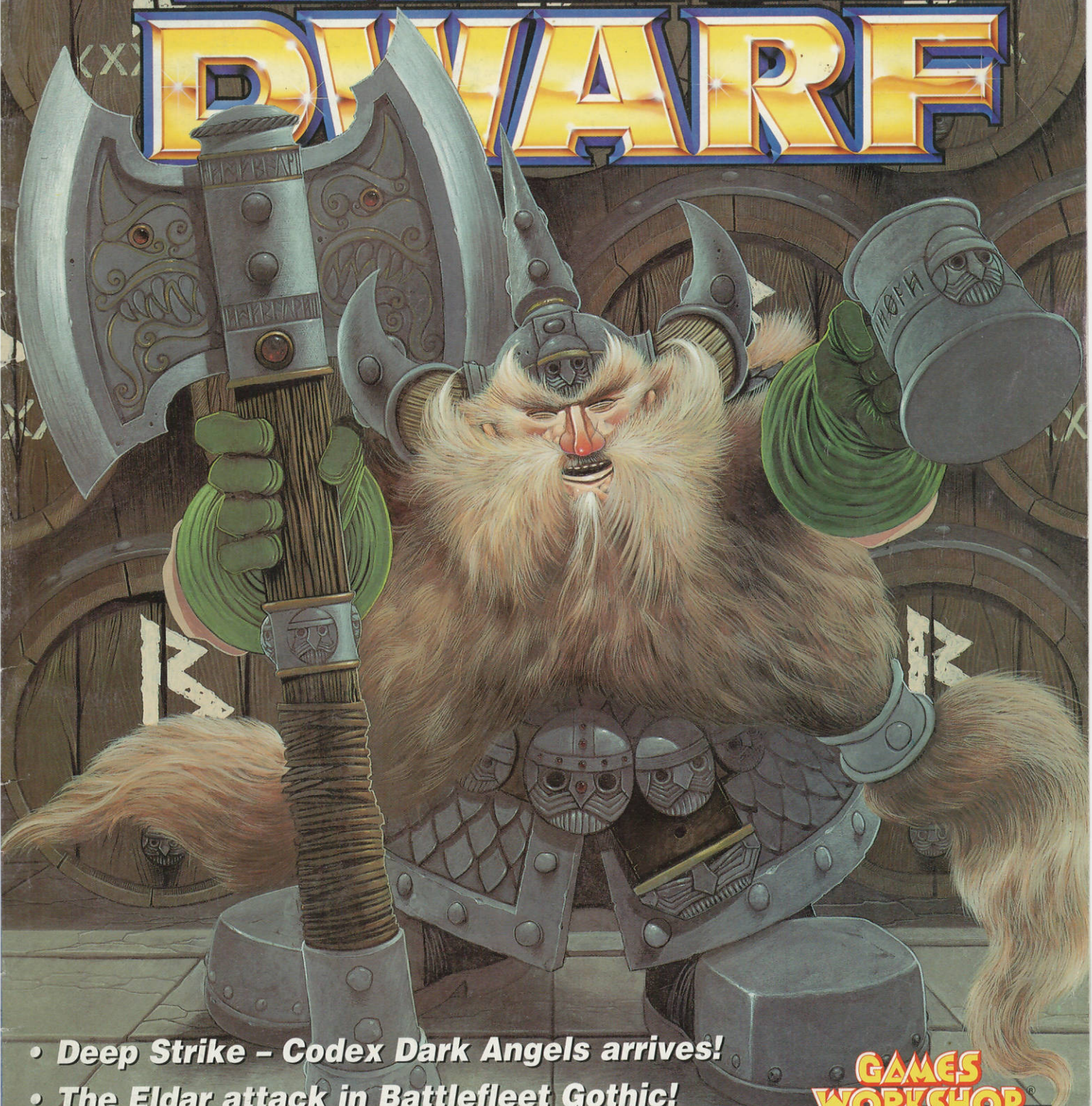

- **Deep Strike - Codex Dark Angels arrives!**
- **The Eldar attack in Battlefleet Gothic!**
- **Exclusive new Regiments of Renown - the Giants of Albion and the Witch Hunters!**
- **3 (yes 3!) battle reports in this issue!**

**GAMES
WORKSHOP**

ISSN 0265-8712



05>

9 770265 871059

WHITE DWARF



JOSEF BUGMAN **COVER**

Art by Wayne England.

GAMES WORKSHOP NEWS **2**

Graham Davey uncovers more strange goings on here at the heart of GW. Strange rumours of Giants, Vampires, Dark Angels, and Eldar Corsairs...

GAMES WORKSHOP STORES **52**

A new month, a new look and new events! What's going on at your local Games Workshop store?

NOTTINGHAM HQ **78**

More forthcoming events here at Games Workshop HQ, including the Battlefleet Gothic Campaign Weekend. Plus details of the Warhammer Open Day and Warhammer Grand Tournament!

THE GRUDGE **96**

Dwarf Lord Gunamar Grudgekeeper attempts to end a centuries old grudge! Will he succeed? Follow his progress in this comic special from the boys at the Black Library.

MAIL ORDER **115**

Seen something you like this issue? Well, here's how to get hold of it! You never know, there may even be a sneak preview or two of soon to be released miniatures...



BATTLEFLEET GOTHIC

SPACESHIP BATTLES IN THE 41ST MILLENNIUM

DE'AYNES FIGHTING SHIPS OF THE GOTHIC SECTOR **60**

De'Aynes turns its attention to the mysterious Eldar corsair fleets that plague the Gothic Sector and were instrumental in bringing victory to the Imperial forces during the conflict.

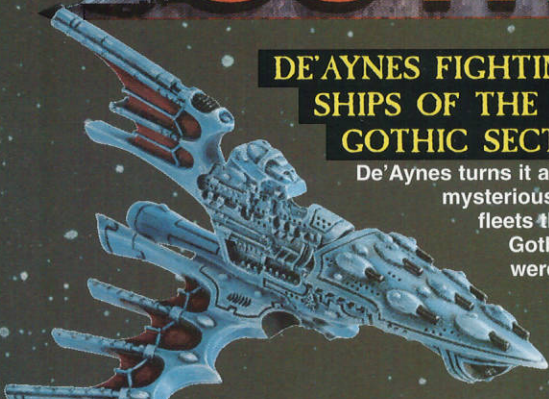

Eldar Eclipse class cruiser

FIGHTING THE ELДАР **66**

Imperial Fleet Admiral Jim Butler brings us a brief treatise on dealing with Eldar raiders.

HUNTER, PREY - THE RAID ON VEDYARIA OUTPOST **86**

The Imperial fleet believe they have caught the Eldar raiders that have been plaguing their sector, but are they falling into a deadly trap of the Eldar's devising? A tense Battlefleet Gothic report between the Imperial fleet of Admiral Che Webster and the Eldar corsairs of the notorious Pirate Prince John Carter.

NEW CONTACTS **94**

Fleet Admiral Nick Davis and Chaos Warmaster Rich Baker take a look at this month's newly released ships and the Blackstone Fortress for Battlefleet Gothic.



Chaos Despoiler class battleship

WARHAMMER

REGIMENTS OF RENOWN 8

They're large, loud, smelly and lost. The Giants of Albion – a new Regiment of Renown exclusive to White Dwarf!

LIKE A RAT OUT OF HELL 25

Mike Walker's indomitable Dwarf army, Bugman's Ultimate Response Patrol, takes on Gareth Hamilton's dastardly Skaven Clan Rat-Fink, in this month's Warhammer battle report.

ELFINCOURT 48

A special Warhammer scenario, based on a certain historical battle in France during the year of 1415, involving knights and longbows.

THE MINES OF KING ZAK-LOMOK 68

Spanish Mail Order Troll Lluís Oliva has built an amazing Dwarf mining village. Jordi Ferré from WD Espana finds out just what went into building it.

BURN THE WITCH 76

Witch Hunter General Tuomas Pirinen opens his journal to bring us the grim tale of the Witch Hunters Johann van Hal and Wilhelm Hasburg.

BAD MOON RISING II 80

At the end of WD229's Empire vs Night Goblins battle report, Jim Butler and Owen Branham promised a rematch. Jim lets us know what happened.

WARHAMMER 40,000

COMPANY OF ANGELS 15

With the release of Codex Dark Angels, Iain Compton sheds some light onto this most sinister Chapter.

RAVEN LOONY 18

Miniature designer Mark Bedford's Dark Angels army.

THE LION & THE WOLF 20

For over a millennia, the Dark Angels and the Space Wolves have been bitter rivals. Bill King (of Gotrek & Felix fame) uncovers the legend that stretches back to the dawn of the Imperium.

A SECRET WAR - THE SCENARIO 42

Since the end of the Horus Heresy, the Dark Angels have been waging a secret war. Jervis Johnson presents a very special mission, with secret player briefings.

WATCH THE SHADOWS 72

Kabal Lord Gav Thorpe introduces the shadowy Mandrakes.

SERIOUSLY SPIKY! 82

The Chaos Predator is out! And with it the plastic Chaos Spiky sprue. New bloke Matt Hutson takes a look at some alternative uses for your spikes (ouch!), then shows how to use Predators and Rhinos in a Chaos Space Marine force.

A SECRET WAR - DARKNESS FALLS 99

The Dark Angels clash with the foul forces of Chaos. Are the Dark Angels there to purge the traitors or for a more sinister reason of their own?



5 011921 970100

Product Code: 6024999233

WHITE DWARF™

THE WHITE DWARF BLOKES

Paul Sawyer



Ming the Merciless

Role: Ruler of the Universe.

What are you painting/modelling at the moment?

Filling out my White Scars Space Marine bike squads to make them up to ten-man squads.

Alias: Fat Bloke

Nick Davis



Zoltar, King of the Hawkmen

Role: Large, loud and featuring a big club.

What are you painting/modelling at the moment?

A Sisters of Battle squad, plus starting an Imperial fleet for Battlefleet Gothic and still doing the odd Dark Eldar model and...

Graham Davey



Dr Hans Zharkov, formerly of NASA

Role: The only one to offer any kind of explanation.

What are you painting/modelling at the moment?

Conversions using the plastic Khorne Berserkers.

Alias: Wordy Bloke

Simon Shuker



Princess Aurora

Role: Not really wearing very much. At all.

What are you painting/modelling at the moment?

A second giant Hive Tyrant, plus four (yes, four) giant Carnifexes.

Iain Compton



Klytus

Role: Very sinister and definitely not human.

What are you painting/modelling at the moment?

Lots of the new escorts for my Battlefleet Gothic Eldar fleet (in the hope of actually winning a game).

Matthew Hutson

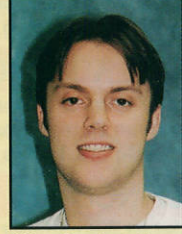

War Rocket Ajax

Role: Bringing back bodies.

What are you painting/modelling at the moment?

A Scout squad for my Black Templars Space Marine army. Also converted a Dreadnought using the new Chaos spiky sprue (look out for it later in this issue).



BOLOGS!

They're big, they're scary, they're big, they're really not very clever and they're big. Er, did we mention that they're big?

The latest in White Dwarf's series of Regiments of Renown is the Giants of Albion. Led by Hengus the Druid, they take employment as mercenaries whenever it is offered, in the hope that it will lead them back home to the misty shores of Albion. And there are plenty of offers, because facing TWO Giants is a terrifying prospect for any enemy.

Also in this issue, Dogs of War Witch Hunters Johann and Wilhelm.

◀The Giants of Albion (this one is named Bologs – the only word he can say) and Hengus the Druid were sculpted by Trish Morrison. For full details and photographs, turn to the article!

DWARF COMIC

Look out later in this issue for a superb Dwarf comic strip from the guys at the Black Library. Written by Gordon Rennie and drawn by Mike Perkins (both regular contributors to Warhammer Monthly), it tells the tale of a Dwarf clan with a long-standing grudge to settle.



CODEX™ DARK ANGELS®



▲ A Dark Angels Tactical combat squad, made up from plastic Space Marine models.

The origins of the Dark Angels are shrouded in mystery. But some of the dark secrets of this monastic Space Marine Chapter are revealed in the new Codex Dark Angels, out this month. The Deathwing, the Ravenwing, the Interrogator-Chaplains, the Fallen – details and rules can be found within...

The Codex contains army listings for creating Dark Angels forces, with options

for all-Deathwing and all-Ravenwing forces. There are special characters, including the Master of the Ravenwing, plus wargear exclusively for Dark Angels characters and a number of special rules that make the Dark Angels stand apart from other Chapters – including the invaluable (or infuriating if you're on the other side) Ravenwing 'jink'. Just like Codex Blood Angels, Codex Dark Angels is a supplement to Codex Space Marines and cannot be used without that book.

Look out for plenty more details about the new Codex later in this issue.

A SECRET WAR

This month's Warhammer 40,000 battle report features a special scenario for the Dark Angels, using the new Codex rules, and a Chaos force led by the mysterious Cypher, the Dark Angels' arch enemy.

Jervis Johnson has written mission briefings for each player, which end with a number of strategic options to choose from. Once the players have decided (in secret), their choices are compared to see what sort of battle will be fought.

We have included the mission briefings in this issue so you can try out the scenario for yourselves. But make sure you avoid reading your opponent's briefing. We also suggest that you don't read the battle report until after you have played, as it may spoil the surprise!



▲ Mark Bedford's Ravenwing squad attacks, in this month's battle report.



▲ The black-armoured Ravenwing is the fast attack force of the Dark Angels Chapter.

BATTLEFLEET GOTHIC™

ELDAR CORSAIRS

The ships of the Eldar race are amongst the most sophisticated in the galaxy, and the crews are arguably the best trained and most naturally able spacefarers of any race.

Eldar ships capture stellar energy through their sails to power their movement, and therefore the distance they can travel depends on their facing with regard to the nearest star. They are graceful and extremely manoeuvrable vessels that can dart in to launch an attack and then pull back before their slower moving enemies have a chance to react. For



◀ Eldar Nightshade class destroyer

protection they employ holofields, which distort targeting sensors and make them very hard to hit.

Check out 'De'Aynes Fighting Ships of the Gothic Sector' later in the issue for details of the individual ships available.



▲ Eldar Shadow class cruiser

SKINK SHAMAN



It is very rare for a Skink to possess any skill in the arts of magic. However, since the time of the rise of the god Sotek, there have been a few Skinks with shamanic and prophetic abilities in every spawning.

Skink Shamans are level 1 wizards who can carry two magic items – making this new model very useful for Lizardman generals.

Nick Davis says: I use my Shaman in an anti-magic role, carrying at least one *Dispel Magic scroll*. I put him in a combat unit of Skinks and Kroxigors so sometimes he gets a magical weapon as his second item.

Iain Compton says: I use Shamans as handy spell-casters, often taking two so there's a good chance of getting a useful spell. They go in skirmishing Skink units so they can easily move into the best place to cast from. The *Jade Amulet* gives a bit of protection.

WARHAMMER MONTHLY 1st BIRTHDAY TOUR

As part of our birthday celebrations, we've got together with some of our artists and writers and organised a signing tour. So if you want to come and chat with your favourite comic writers and artists, and get your Warhammer Monthly signed, check out the list of dates below.

GUESTS	STORE	DATE
Ralph Horsley, Wayne Reynolds	Leeds, City Centre	17th April
Kev Hopgood, John Gravato	London, Plaza	24th April
Paul Davidson	Newcastle	24th April
Simon Davis	Birmingham	24th April
Karl Kopinski, Paul Staples	Nottingham	1st May
Mike Perkins	Worcester	1st May
Gordon Rennie, Colin MacNeil	Edinburgh	8th May
Kev Walker	Leeds, City Centre	8th May
Dan Abnett	Maidstone	8th May
David Pugh	Cardiff	15th May
Gordon Rennie, Colin MacNeil	Glasgow	15th May
Simon Coleby	Norwich	22nd May
Mike Perkins	Wolverhampton	29th May

These dates are only provisional. Please ring the store nearer the time to confirm that the signing is going ahead and what time the guys are going to be there.

NEWS

NEW RELEASES THIS MONTH



This month's Battlefleet Gothic releases:

Blackstone Fortress Space Station (metal boxed set) £12.00

IMPERIAL

Imperial Dauntless class light cruiser (one model per blister) £5.00

Imperial Firestorm class frigates (three models per blister) £5.00

Imperial Emperor class battleship (metal boxed set) £12.00

CHAOS

Chaos Iconoclast class destroyers (three models per blister) £5.00

Chaos Despoiler class battleship (metal boxed set) £12.00

ELDAR

Eldar Shadow class cruiser (one model per blister) £8.00

Eldar Aconite class frigates (three models per blister) £5.00

Eldar Hemlock class destroyers (three models per blister) £5.00

Eldar Eclipse class cruiser (one model per blister) £8.00

Eldar Hellebore class frigates (two models per blister) £5.00

Eldar Nightshade class destroyers (three models per blister) £5.00



This month's Warhammer releases:

LIZARDMEN

Skink Shaman (one model per blister) £3.00

DOGS OF WAR

Giants of Albion (metal boxed set – two Giants plus Druid) £25.00

Wilhelm and Johann (two models per blister) £6.00



This month's Warhammer 40,000 releases:

CHAOS

Chaos Predator (metal and plastic boxed set) £20.00

SPACE MARINES

Codex Dark Angels £4.00

Dark Angels Ravenwing Command (metal and plastic boxed set – Sergeant plus two bikers) £20.00

DARK ELDAR

Dark Eldar Lord (one model per blister) £6.00

Dark Eldar Mandrakes (three models per blister) £5.00

Drazhar, Master of Blades (one model per blister) £6.00



This month from the Black Library:

Warhammer Monthly 15 £2.00

Inferno 12 £5.00

Mutterings from the

Black Library



I'm afraid the bad news for all you Kal Jerico fans out there is that the superb, limited edition miniature has completely sold out. But do not despair, for we have another absolutely cracking limited edition miniature ready. As some of you may already know, the next special collector's miniature to come out of the Black Library is none other than Captain Leonatos from the Bloodquest comic strip. It's not available from the stores or via GW Mail Order, so if you want to get your mitts on this fabulous miniature, take a look at Warhammer Monthly for more details.

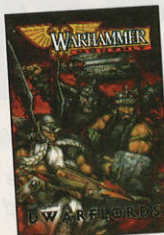

If you've been following the progress of those masters of mayhem, the Dwarflords, then you'll know that their epic journey is almost at an end. However, they must still battle their way through the vast Chaos army besieging their home of Karak Kadrin. But it'll all be worth it for the reward of a fair Rinn and a foaming mug of Bugman's ale. Also find out all about the creator of Dwarflords, Paul Davidson, in our special feature interview – only in issue 15 of Warhammer Monthly.

In the depths of the Underhive, every good ganger knows you must always watch your back if you are to stay alive. Well the Hive just got more dangerous with another mayhem-packed issue of Gang War hitting your stores this month. The second issue has another 48 pages of new gangs, scenarios and house rules for your games of Necromunda, including Orks in the Underhive, Wyrd Gatherings, Necromovies and much more.



Finally, if you like rip-roaring short stories then the latest issue of Inferno! hits the shops this month. And speaking of fiction, we have some great news: William King popped into the Black Library, on a daring mission from Prague. Attempts to capture the rogue writer failed and Mr King made his escape, leaving behind the final manuscript for Trollslayer, the first Gotrek and Felix novel! As well as this, Dan Abnett is also working on a Gaunt's Ghost novel. We'll be bringing you further details of this exciting new project in an issue of White Dwarf very soon. Don't forget to check out our new Website, it'll have all the latest news about novels and other Black Library products. Here's the URL: <http://www.blacklibrary.co.uk>

COMING SOON

Out next month is *Warhammer Armies Vampire Counts*. This new book covers the evil Vampires of Sylvania, in all their forms, and details the hideous Undead minions of their armies.



◀ A Blood Dragon armoured Vampire knight.



▲ In the pipeline is a *Warhammer Regiment* of multi-part, plastic Zombies, which look like they're going to be absolutely awesome.

Out next month, the *Ork* fleet for *Battlefleet Gothic*. Pictured here, a *Kill Kroozer*.▶

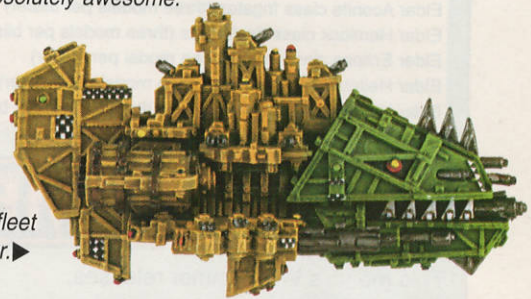

PORTUGUESE TRANSLATOR

The editorial department in our Spanish studio is looking to recruit a Portuguese Translator.

To be successful in this role you will need to be an enthusiastic Games Workshop hobbyist, fluent in Portuguese and either English or Spanish. Knowledge of Macintosh computers & Quark Xpress would also be useful.

If you have the above qualities and have experience of working within an editorial environment, please send your C.V. to:

*Portuguese Translator Vacancy
Games Workshop
Motores 300-304
Poligono Gran Via Sur
08908 L'Hospitalet de Llobredgat
Barcelona (Spain)*



WHITE SCARS DREADNOUGHTS



Since WD230, Fat Bloke has been literally inundated with suggestions for ways in which his Dreadnoughts could keep up with the rest of his fast-moving White Scars Space Marine army.

Your ideas included giving the Dreads tracks, enormous jump packs, transporting them on specially converted 'flatbed' Rhinos or even making a 'Hover-Dreadnought'. Paul would like to thank everyone who wrote in – he has passed on the best letters to Gav Thorpe.

A SUPERB OPPORTUNITY TO WORK IN MAIL ORDER TELESALES AND SERVICE THE WORLD...

Games Workshop Mail Order is a vital part of our UK Sales business. It provides an excellent service to hobbyists all over the world – it is Games Workshop on the end of a phone.

Mail Order supplies whatever the customer needs, even down to individual components. We do not believe in the 'allow 28 days for delivery' philosophy; all orders are despatched within 24 hours.

Mail Order deals with up to 1,000 calls per day, and each caller is greeted by a member of the telesales team, who are there to answer queries, suggest models for the caller's army, put orders onto our computerised system and to respond to any customer service issue that may arise.

We are now looking for people to expand our Mail Order business in the UK.

We are also looking for people with language skills, especially Danish, Dutch, French and German, to provide a quality service to our overseas customers.

The Skills

- Huge passion for the Games Workshop hobby
- Enjoy talking to people of all age groups
- Excellent communication skills
- A good telephone manner
- Previous telesales experience would be useful but not essential

The Person

- Loads of energy and enthusiasm
- Able to use your initiative
- Confident
- Good sense of humour
- Customer service orientated – you will know the need for excellent customer service

The Benefits

- We provide competitive salaries, staff discount, excellent training, almost unlimited career opportunities all over the world and all the benefits you would associate with a multi-national company.

Send your C.V. or application form, stating why you think you can be an essential part of the Mail Order team to:

ROB GRIFFITHS, UK SALES PERSONNEL DEPARTMENT, GAMES WORKSHOP LTD,
WILLOW ROAD, LENTON, NOTTINGHAM, NG7 2WS. TEL: 0115 916 8172. E-MAIL: robg@games-workshop.co.uk



**GAMES
WORKSHOP**

WARHAMMER

DOGS
OF
WAR
FOR
HIRE

DOGS
OF
WAR
FOR
HIRE

REGIMENTS OF RENOWN



By Nigel Stillman

They're large, loud, smelly and lost. White Dwarf continues its series of exclusive, new Regiments of Renown for hire. This month Nigel Stillman peers into the misty realm of Albion and uncovers the legend of Hengus the Druid and two of the mightiest giants in Albion, Bologs and Cachtorr – who want nothing more than to go home...

DOGS OF WAR

The Dogs of War are mercenaries who live by fighting – for glory and more importantly for gold! They don't necessarily have ties to a particular country, nor are they a whole new race. Skilled warriors, deadly marksmen, Arabian cavalry, treacherous Hobgoblins and banished High Elf princes are among the units filling out the ranks of the Dogs of War.

Many mercenary regiments are made up of many different races and have no common heritage bar the lure of the paymaster's paychest, though many find employment in that notorious mercenary breeding ground, the land of Tilea. Tilea is an anarchic land, as the wealthy merchant princes of the independent city states plot against each other and sponsor expeditions into the unknown. All this anarchy means mercenaries who travel there can be assured of profitable employment.

THE REGIMENTS OF RENOWN

Regiments of Renown can be incorporated into your existing Warhammer armies very easily. Just add the regiment's points cost to the allies allocation of your army list.

All Regiments of Renown have a unique character, so you can only use one of each regiment in your army. Also, each regiment is only available to hire for a limited selection of armies as, for example, even an exiled High Elf prince would never work for Dark Elves no matter how much money they are offered. Instead of hiring individual regiments, you can raise an entire Dogs of War army. All you need is a Mercenary General to lead it and a Paymaster to dish out the gold.

READY FOR HIRE

The Dogs of War armies book contains fifteen Regiments of Renown for hire, and in White Dwarf we have detailed Lumpin Croop's Fighting Cocks (WD230), Ghazak Khan – Mercenary General (WD231), Oglah Khan's Hobgoblin Wolfboyz (again WD231) and Tichi-Huichi's Skink Cold One Raiders (WD232). But there are still many more famous mercenary regiments and characters scattered around the Old & New World.

This issue we bring you the Giants of Albion and elsewhere in this magazine the Witch Hunters Johann van Hal and Wilhelm Hasburg.

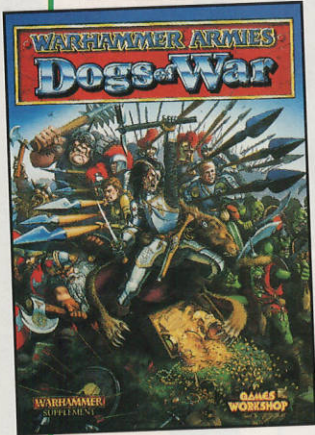

With the promise of a one way ticket back to Albion, Hengus and the Giants join a mercenary army.

HENGUS THE DRUID & THE GIANTS OF ALBION

Sculpted by Trish Morrison



▲ Hengus the Druid



▲ Cachtorr, Bologs' twin brother



▲ Bologs, mightiest of all Albion Giants



▲ Hengus the Druid & the Giants of Albion, Cachtorr (right) & Bologs (left).

THE GIANTS OF ALBION

By Nigel Stillman

I say! It was most unsporting. My fellows and I barried Ranoldo and his band of ruffians all the way to the Trantine hills. Then Ranoldo unleashed those horrid Albion Giants upon us, led by a rather hairy looking fellow. They smashed our line, squashed poor old Hoskins Hotshot, whilst shouting the loudest uncouth word I have ever heard. If those Giants are typical of that island, I for one am glad it remains unexplored.

High Elf Lord Daverion, Gentleman Mercenary General.

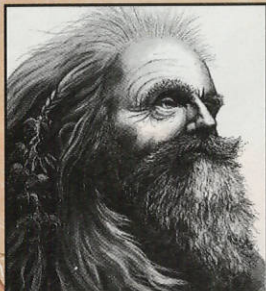

The Druids of Albion say that the race of mighty Giants that inhabit their island were put there by the Old Ones to guard the island from intruders. Whether this is true, who can say? Yet the Giants prowl the rugged coasts to this day. They wander along the fog shrouded cliffs and hurl boulders down onto hapless ships which come too close to the shore, taking a

childlike joy in watching them splinter into matchsticks and the doomed crew struggling in the fierce waves. The Druids have a strange power over the Giants and can goad them into lifting up and carrying huge boulders and monoliths. With the help of the great strength of the Giants, these huge stones are arranged in rows or circles in order to measure the movements of the sun, moons and stars.

Greatest of all the Giants is Bologs. He is worshipped as a god by the primitive, cave-dwelling tribes of Albion, who have carved his image into the chalk hills of their land, brandishing his mighty chopper. Awesome though he is, Bologs' intellect is dim, even for a Giant of Albion. The only

thing that he can say is his own name. One day he was roaming the clifftops when the mist cleared for a moment to reveal the murky grey sea and pebbly beach. Bologs spied a landing party of Elves upon the shore far below. They also saw the Giant towering above them on the clifftop. The leader of the Elves shouted up to him in the tongue of the Druids of Albion, "We come in peace! We seek only to trade!" On hearing the words which he could not understand, the Giant grinned and replied "BOLOGS!" Then he hurled down a great boulder which flattened all the Elves as it embedded itself in the shingle.

The next greatest Giant in Albion is Cachtorr, twin brother of the mighty Bologs. He is slightly more intelligent than Bologs and is able to understand the speech of the Druids. It was Cachtorr who fought against the mighty Dong and his mate, Mae-Dong, two terrible Giants from the far north of Albion. This legendary fight lasted for several hundred years and involved hurling huge boulders whenever the mist cleared long enough for one Giant to see the other. Most of these missed, but wherever they landed, they stuck into the ground to remain there forever as menhirs, marking out the territories of the feuding Giants.

Albion remained shrouded in the dark mists of legend until the renowned Tilean general, Curious Gearar, first citizen of Remas, set foot on the island, leading his

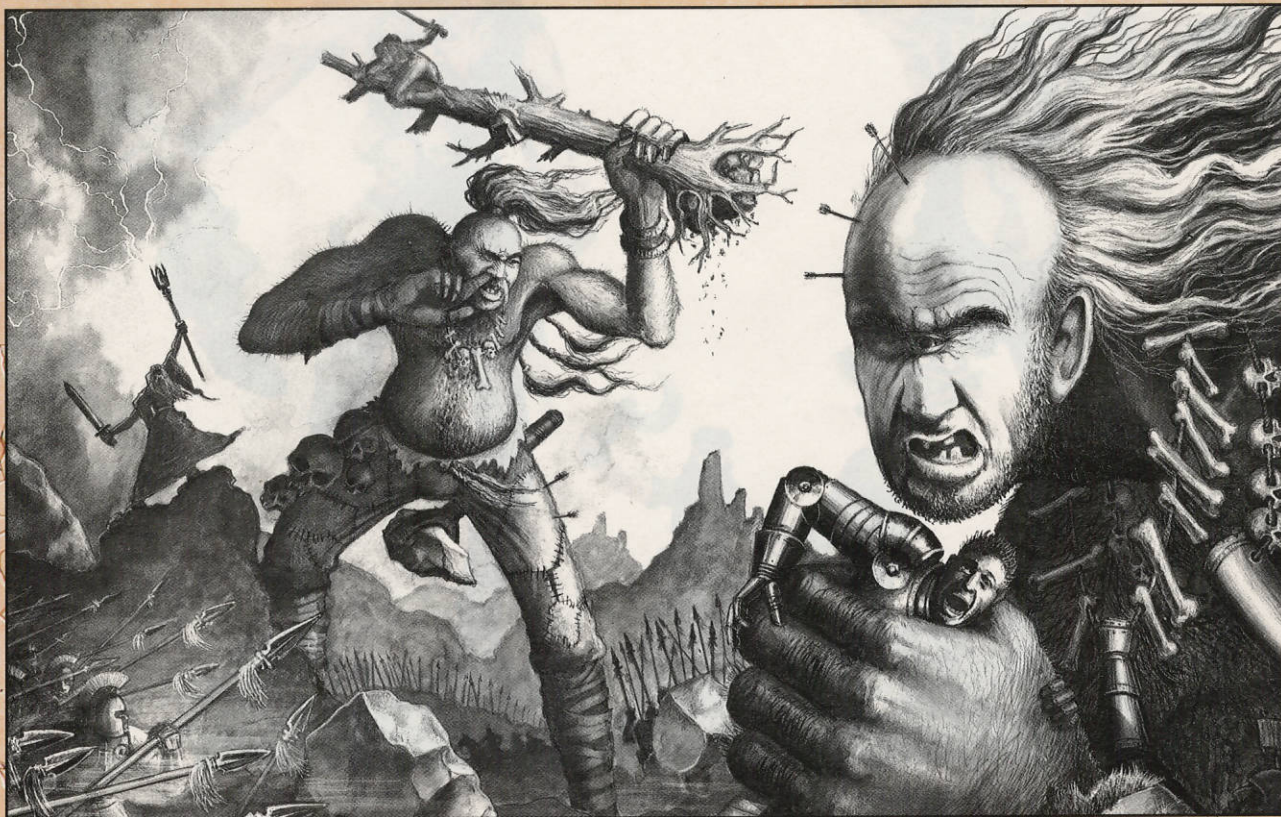

invincible army. Geasar sought fame and power in Remas and how better to win it than to conquer misty and mysterious Albion, rumoured to be full of gold and pearls and the treasure of the legendary Triton himself. As the galleys ploughed through the surging surf onto the shingle of the beach, Cachtorr and Bologs stood on the cliffs, hurling rocks down onto the ships, smashing them to pieces. The men were filled with horror and were scared to wade ashore. So Geasar heaved the army pay chest over the side of the ship into the surf, scattering the gold among the pebbles and jumped ashore after it. Seeing this, the entire army did likewise until the pay chest was safe behind their battleline.

Ignoring the boulders of the Giants and stepping over the fallen, Geasar and his army marched up the beach. Soon they found themselves confronted by all the savage tribes of Albion, numerous Giants and demented Druids uttering dire curses, formed up in battle array on the cliffs – and then it rained. The mercenaries stubbornly refused to go any further! Curious Geasar was enraged. How could he return to Remas in triumph now? What exotic booty could he bring back to awe the multitudes? How could he boast his conquest of distant and mysterious Albion?

Angrily Geasar strode forward and harangued the multitudes of savage tribesmen. "Oh foolish barbarians! I offer you all the benefits of civilisation: roads, hot baths, money, public buildings and Tilean poetry. Submit and all these things can be yours!" The tribes of Albion just glowered at him. Then he heard a single word bellowing back at him out of the fog and driving rain: "BOLOGS!" All at once the Giant's battle cry was taken up by the tribesmen banging their clubs and stone axes against their shields and the sides of their chariots and chanting "Bologs, Bologs, Bologs!"

Geasar was dismayed and ordered his men to charge. The battle was fierce with victory going to neither side. After a day's fighting, with the mist-shrouded sun descending into the sea, the two sides paused a few yards apart, utterly exhausted. Geasar tried one last gamble to save face. He could not return to Remas humiliated and empty handed. He needed something awesome to parade in his triumph, in order to win popularity with the mob. Geasar strode forth and shouted: "Give me Giants as hostages and I will go away." The Druids who knew Tilean from their occasional contacts with merchants considered his offer. They knew that their stone axes were no match for Tilean steel. At long last old Hengus volunteered to go and choose two of the smaller Giants to go with him. As they strode forward, Geasar shouted "I want the big ones!" and pointed to Cachtorr and Bologs, greatest of Giants. Despite the protests of the tribesmen, the Druids sent forth the two mighty Giants to be hostages in Remas in order to save old Albion from conquest and the tribes from enslavement or worse, the decadence of luxury and civilisation.

Geasar repaired half his fleet and sailed away with his Giant hostages wading in the sea behind him, tied by anchor chains. The moment Geasar's fleet arrived in Remas, word spread throughout the city. Geasar's political opponents had awaited this very moment and hastily made way to the harbour. They gathered around the mighty conqueror as he came ashore and showered him with the usual grovelling praises. This was just to put him off his guard for instantly he was horribly done to death with many daggers. Up came the cry "Geasar is dead, long live the republic!" Geasar's battered and seasick soldiers panicked and scattered, seizing what gold they could in the confusion. One of

them, out of spite against the city rather than pity for their plight, broke the chains that bound the Giants and released Hengus from the hold. Moments later Cachtorr and Bologs stormed ashore and went on the rampage through the streets of Remas, causing the citizens to flee in abject terror. Soon the Giants were in open country, spreading fear and panic throughout Tilea with Hengus close behind.

Since that day, Hengus and the Giants of Albion have lurked in the landscape, lost and confused, seeking shade from the hot sun and pining for the fog. Not surprisingly, various mercenary generals have sought them out to hire them as dogs of war. Hengus, willingly agrees to fight in the hope that the campaign will lead him near to the great ocean and ultimately to Albion.

THE REGIMENT

Captain: Hengus the Druid.

Motto: We've got the Bologs to beat anybody.

Battle-cry: BOLOGS!

Appearance: The Giants of Albion are many and varied. Most have only one eye in the middle of their foreheads, and some even have two heads. What little clothing they have is made of the hides of huge beasts such as mammoths, sabre tooth tigers, elks and cave bears. They wear necklaces made from the tusks of mammoths and wild boars.

For Hire: Any Warhammer army can hire Hengus and the Giants of Albion.

Points: Hengus, Cachtorr and Bologs cost a total of 495 points.

Profile	M	WS	BS	S	T	W	I	A	Ld
Hengus the Druid	4	3	3	3	4	1	4	1	7
Bologs	6	3	3	7	6	6	3	S	6
Cachtorr	6	3	3	7	6	6	3	S	6

Weapons/Armour: Both Giants are armed with gigantic stone battleaxes. Hengus is armed with a hand weapon.

Armour Save: None. (Hengus has 4+ special save).

SPECIAL RULES

Giant Special Rules: Cachtorr and Bologs are Giants and subject to the special rules for Giants (*see Warhammer Battle Book p126*). Hengus the Druid is a level 1 wizard and uses battle magic.

Oggum Staff: Hengus has an Oggum Staff, which is a special kind of magic item made by the Druids of Albion. Not only do the Oggum marks on the staff endow the bearer with power over Giants to make them serve him, but they also protect the owner from harm. To represent this, Hengus has a special save of 4+ against wounds caused in any way whatsoever.

Independent Models: Hengus, Cachtorr and Bologs are individual models and can move independently, though they may not join regiments. The enemy is awarded 2 victory points for each Giant slain and 1 victory point for killing Hengus. As long as the Giants are within 6" of Hengus, they may use his Leadership and are immune to Panic tests.

WARHAMMER LORD DAVERION'S HIGH ELF EXPEDITIONARY ARMY



◀ High Elf Lord Daverion and Avour the Mage
 ▶ Silver Helm Knights



◀ High Elf battleline (clockwise from top): repeater bolt thrower, Archers, Swordmasters of Hoeth and Spearmen.

WARHAMMER ROSTER SHEET

LORD DAVERION'S EXPEDITIONARY ARMY

Models/Unit	M	WS	BS	S	T	W	I	A	Ld	Save	Notes	Points Value
LORD DAVERION Elven Lord, Army General Ithilmar armour, shield, sword & barded Elven Steed	5	7	7	4	4	3	9	4	10	2+	Magic Weapon; Blade of Sea Gold	201
	9	3	0	3	3	1	4	1	5	-		
AVOUR THE MAGE MAGE Sword & barded Elven Steed	5	4	4	3	4	1	7	1	8	5+	Level 1 Wizard (uses High or Battle magic)	66
	9	3	0	3	3	1	4	1	5	-		
SILVER HELM CAPTAIN ARIEN Elven Champion, light armour, shield, lance & barded Elven Steed	5	5	5	4	3	1	7	2	8	3+	Leads the Silver Lancers	60
	9	3	0	3	3	1	4	1	5	-		
CAPTAIN MAR'ICK Elven Champion, light armour, shield, spear	5	5	5	4	3	1	7	2	8	5+	Leads the Silver Spears	52
	9	3	0	3	3	1	4	1	5	-		
SILVER LANCERS 7 SILVER HELMS, Light armour, shield, lance, sword & barded Elven Steed	5	5	4	3	3	1	7	1	8	3+	Unit includes standard & musician	369
	9	3	0	3	3	1	4	1	5	-		
SWORDMASTERS OF HOETH 15 SWORDMASTERS, Heavy armour, two handed sword	5	5	4	3	3	1	7	1	8	5+	Unit includes standard & musician	272
	9	3	0	3	3	1	4	1	5	-		
SILVER SPEARS 19 ELVEN SPEARMEN, Light armour, shield, spear	5	4	4	3	3	1	6	1	8	5+	Unit includes standard & musician	252
	9	3	0	3	3	1	4	1	5	-		
SILVER ARROWS 12 ELVEN ARCHERS Longbow, sword	5	4	4	3	3	1	6	1	8	5+		132
	9	3	0	3	3	1	4	1	5	-		
REPEATER BOLT THROWER ELVEN CREW light armour, sword REPEATER BOLT THROWER	5	4	4	3	3	1	6	1	8	6+	Special rules; see High Elf Armies book	100
	-	-	-	-	7	3	-	-	-	-		
THE GIANTS OF ALBION HENGUS THE DRUID,	4	3	3	3	4	1	4	1	7	4+	Level 1 Wizard (uses Battle magic) Magic Item; Ogum staff Special rules; see WD233 p48	495
	9	3	0	3	3	1	4	1	5	-		
BOLOGS	6	3	3	7	6	6	3	*	6	-	*Special rules; Battlebook p126 *Special rules; Battlebook p126	
CACHTORR	6	3	3	7	6	6	3	*	6	-		
TOTAL											1,999	

Warhammer is a registered trademark of Games Workshop Ltd. © Copyright Games Workshop Ltd. 1996. All rights reserved.
 ENGLISH Roster Sheet 102854
 Permission is granted to photocopy this sheet for personal use only.



The High Elves are great sailors and explorers. At any one time there are expeditions searching the Old (and New) World for lost Elven relics, new trade routes, mythical treasure hordes and even new lands to conquer.

These expeditions often explore hostile lands and the High Elf explorers must be prepared to defend themselves. Many expeditionary forces are really small armies. Lord Daverion's expedition is no exception. For magical protection he has brought along Avour the Mage. Accompanying Avour are a contingent of Swordmasters of Hoeth. These mystical warriors are so highly skilled that they are able to knock arrows out of the sky with their long swords.

Also volunteering to join Lord Daverion's army are a number of noble Silver Helm knights, led by the noble Captain Ariën. The rest of his army is made up from the versatile citizen-soldiers of Ulthuan and the expedition's ships' crews. And in case Lord Daverion needs some long ranged support, he has ordered one of the ships' repeater bolt throwers to be made transportable.

Although the High Elves don't traditionally hire Dogs of War to supplement their own armies, there are many times when an Elven lord has to be practical. Through unknown diseases and battle casualties, expeditionary forces' numbers do dwindle. So Lord Daverion has chosen to hire a Regiment of Renown to strengthen his army.

Expeditionary forces can find themselves facing large, dangerous monsters. While Lord Daverion's army is not lacking in martial skill, it can find itself out-classed in terms of raw strength. So he has hired the fearsome Giants of Albion to help him deal with this sort of problem and to add some serious power to his battleline.

The Regiments of Renown are ideal for covering the weaknesses in your battleline and add a unique character to your army.

▲ The Giants of Albion – Bologs, Cachtorr & Hengus the Druid.

FROM THE DEPTHS OF THE **UNDERHIVE!**

48 PAGES OF COOL STUFF
IN EACH ISSUE!!



**ONLY
£2.75
EACH!**

NEW GANGS & RULES FOR NECROMUNDA ISSUES 1 & 2 – OUT NOW!

WARHAMMER
40,000

Company of Angels

By Iain Compton



Iain Compton

This month, the eagerly awaited Codex Dark Angels hits the shelves. We take a look at what makes them so different from other Space Marines, as Iain delves into the mysteries and rumours that surround this most secretive of all the First Founding Chapters.

I have always liked the Dark Angels. Some time ago I put together a Dark Angels army of my own and, although I have recently been spending more time on my beloved Eldar, I had some memorable games with the Space Marines and really immersed myself into the mythos surrounding this enigmatic Chapter. The way that their secretive background combines with some of the most characterful Space Marine miniatures ever made, really set my imagination going.

I find it really hard to pin down what I like best about the Dark Angels Chapter. They seem to have it all – but if I was pressed, I would probably say that the background really brings it all together for me. The Dark Angels harbour a terrible secret and they are prepared to go to incredible lengths to make sure that nobody else ever finds out about it. Like all Space Marines they are utterly focussed on their duty as they see it, but because of the grim events of their past they are occasionally prepared to deviate from the accepted path of righteousness.

In many ways they are the closest of all the loyal Chapters to Chaos Space Marines. Even other Space Marines, not exactly known

for their mercy and compassion, do not usually find it necessary to hunt people down and torture them to death in a variety of gruesome ways – a course of action the Dark Angels often pursue.

Codex Dark Angels is a supplementary booklet detailing rules for one Chapter, and is designed to be used alongside Codex Space Marines – so make sure that you have a copy of that book too!

Released alongside the Codex is the Ravenwing Command Squad boxed set, allowing you to include Veteran Sergeants and special weapons troopers in your Ravenwing bike squads. This boxed set contains three Space Marine bikes, three metal Ravenwing biker torsos and a variety of special parts to build a sergeant and a flamer Marine – check them out over the page!



The Codex includes: rules, background, squad markings, painting schemes and all the information that you need to collect your own Dark Angels force.



The grim guardians of Humanity stand ready to battle against the enemies of the Imperium.

The Dark Angels – An Excerpt from the Historia Astartes Vol. LMXI



As with so much of the most ancient history of the Imperium, the origin of the Dark Angels is lost in legend. All that is known for sure of the early history of the Chapter is that they were the first and the largest of the original Space Marine Legions in what has become known as the Great Crusade. During these times their Primarch, Lion 'El Jonson, was instrumental in planning some of the most difficult campaigns. Following the terrible blow of the Warmaster's treason, the history becomes confused and obscure. It is thought that Jonson survived the Heresy but of his fate immediately after, nothing is known for sure – although rumour and speculation are rife. Some sources have it that Jonson was killed in battle with a monster of the warp on his way back to the Dark Angels' home world of Caliban. It seems more likely however that he was caught up in the still unexplained destruction of Caliban itself. A recurring legend has it that Jonson still roams the Galaxy, searching for some unknown enemy. This enemy may be alluded to obliquely in the annals of the Dark Angels themselves.

After the Great Betrayal, the Dark Angels were reorganised into a Chapter, in line with the other Space Marine Legions that remained, and have since sired several Successor Chapters. Of these, the Angels of Absolution, the Angels of Redemption and the Angels of Vengeance have particularly close links with the Dark Angels themselves. The four Chapters collectively call themselves the Unforgiven, although a satisfactory answer is yet to be given as to why this should be. In the last ten millennia, the Dark Angels have continued their Primarch's tradition of conducting particularly effective and well-planned campaigns, although some observers have noted instances where the Chapter or one of its successors have failed to support Imperial forces or take other action when requested to do so, and have further failed to give a satisfactory explanation for this. In at least seven hundred and fifty reliably documented instances, the 'Unforgiven' have abandoned a campaign at a critical juncture with no reason being offered to explain this extraordinary behaviour. It is postulated that these Chapters may have some hidden agenda which has priority even over service to the Emperor himself. This is, to say the least, possibly treasonable and at worst Heresy. To date, however, despite continued and intensive covert Inquisitorial investigation, the Adeptus Terra is still unable to explain this anomalous behaviour in an otherwise superb service record.

Chapter Organisation

The Dark Angels conform closely in most respects to the pattern set down by Roboute Guilleman in his great work the Codex Astartes. They have ten companies, each with the normal supernumeraries such as a Chaplain, Librarian, Apothecary etc, and a pool of vehicles including all currently issued Space Marine vehicle patterns. The main differences between the Dark Angels and an orthodox Codex Chapter (such as, for example, the Ultramarines), are in the 1st and 2nd Companies.

The 1st Company, in common with other Codex Chapters, is a Veteran company. But unlike most Veteran companies its members are not equipped with standard pattern power armour; instead they are only ever deployed in Tactical Dreadnought armour. All ranking members of the Chapter are nominally members of this 1st Company, known as the Deathwing, although this seems to be an honorary title as they continue to fight as normal with their own units, wearing power armour. It is postulated that the ranking officers of the Dark Angels, and possibly some of the Successor Chapters also, form some kind of secret council within the Chapter which is linked in some way to their membership of the Deathwing, and possibly has bearing on the Chapter's unexplained absences from duty.

The 2nd Company is not a battle company as would be the case with other orthodox Chapters. Instead, this company, known as the Ravenwing, is entirely composed of strike vehicles. All the bikes, attack bikes and Land Speeders are held within this company instead of being distributed through the Chapter as would normally be the case. This highly specialised formation has earned enormous renown for the supreme levels of skill shown by its members in battle situations.

Other Distinguishing Anomalies

While the Codex prescribed colour for the Chapter's armour is dark green, the first two Companies do not use it. The Deathwing wear bone white armour, harking back to a tradition from their original home world, while the Ravenwing wear unrelieved black armour, echoing their namesake, a legendary bird from the writings of an ancient Terran scribe named Id'garr Alunpo. Both these Companies also wear a modified version of the Chapter symbol, further breaking with tradition.

The final notable difference between the Dark Angels and practically every other Chapter, whether conforming to the Codex pattern or not, is the nature of their Fortress Monastery and recruiting process. As mentioned before, the Dark Angels do not have a home world. Their original home, Caliban, was destroyed shortly after the Horus Heresy. Rather than adopt a new home world, they have built their fortress-monastery upon a reclaimed asteroid. This asteroid, known simply as 'The Rock', travels about from planet to planet, recruiting from a variety of worlds. This diversity in the recruiting process is almost unheard of amongst the Space Marine Chapters, most preferring to draw their recruits from a single world or system. It might be assumed that such a cosmopolitan selection process could translate into a similarly open attitude to those that they serve with, however there are plenty of documented cases of the Dark Angels adamantly refusing and even actively discouraging offers of support from other Imperial units. While a complete intolerance of abhumans and aliens is expected of Space Marines, the Dark Angels are even unwilling to fight alongside standard Human troops. Whether this is due to simple arrogance or some deeper motive can only be guessed at. It must be borne in mind that Space Marine Chapters are not subordinate to the Adeptus Terra and are not obliged to respond, although it is unusual, to say the least, for any Imperial unit, even one with as much autonomy as a Space Marine Chapter, to ignore reasonable requests for assistance.

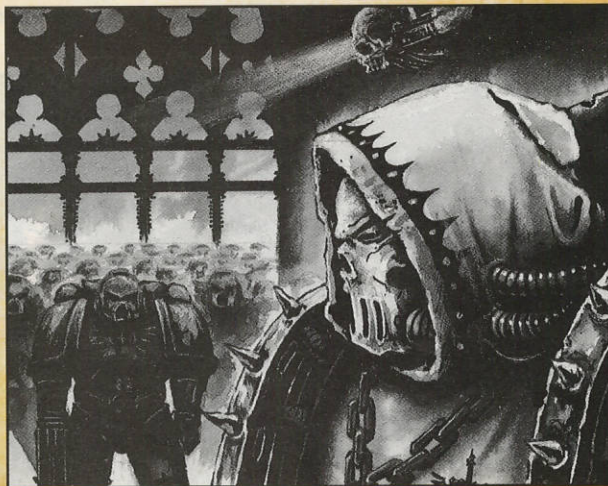

RAVENWING COMMAND SQUAD

Shown here are the three Space Marine bikers from the new Ravenwing boxed set. As you can see, they come festooned with Dark Angels Chapter symbols and the Ravenwing badge. The really great news is that all these metal parts can easily be combined with the plastic Space Marines, allowing you to incorporate the Dark Angels markings into, for example, your Dark Angels Tactical squads as well! The metal flamer arm, particularly, is sure to turn up in loads of Space Marine conversions.



Azrael, Supreme Grand Master of the Dark Angels, accompanied by a helmet bearer carrying the Lion Helm.

The enemy has been sighted. I am going to engage. In the name of the Emperor; Ravenwing – Attack!, Attack!!, ATTACK!!!

– Grand Master Gidian of the Ravenwing



Deathwing Terminators



(below) The Ravenwing storms a heavily defended Eldar bunker. Dark Angels, in common with all Space Marines, have an enduring hatred for all aliens and non-humans.

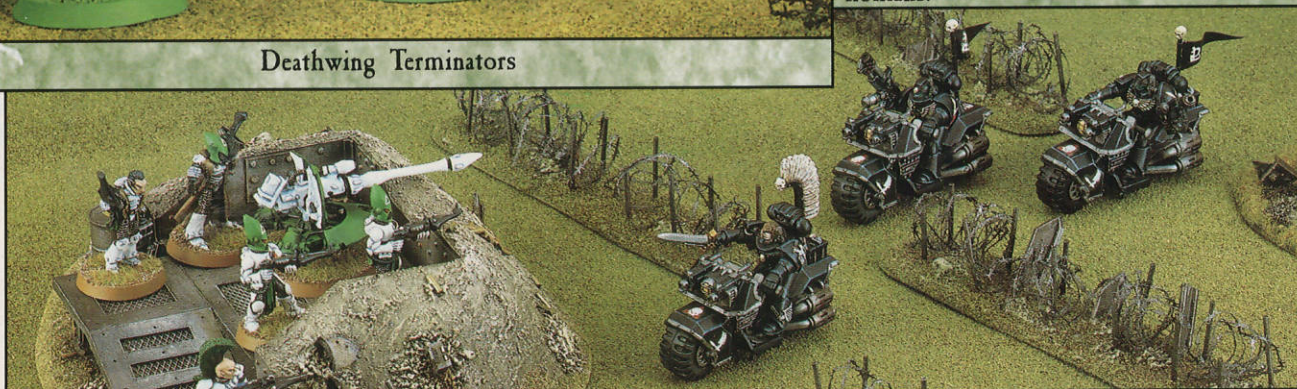

RAVEN LOONY!



Mark Bedford

As well as being a talented miniature designer, Mark Bedford is a bit of a Dark Angels nut. As you will see later, Mark plays the Warhammer 40,000 battle report using the Studio Ravenwing army, with a few of his own special touches. He also has his own fantastic Dark Angels army. Iain Compton saddles up and takes a closer look.

Mark has been collecting Dark Angels for a while now. The force started out as an allied contingent for his Imperial Guard army, but the robed warriors gripped his imagination to such an extent that now he's collecting a complete army.

The next thing for his army will be a lot of bikes and Land Speeders. Mark says "After playing the battle report, I have really got into the idea of a Ravenwing army – there are just so many cool modelling opportunities in a force like that. I want to be able to field absolutely hundreds of bikes and have each one different!"

All right Bedford, we've heard enough! Get back into the cupboard...



Mark's heavily camouflaged Scout squad. Mark has used plenty of references from real life military units to create a very realistic effect.



Mark is a bit of a tank fan, as you can see from these two heavily converted vehicles. Mark has used a lot of reference material on modern tanks to make his Whirlwind and Rhino look more realistic. Check out the ablative armour on the Rhino!

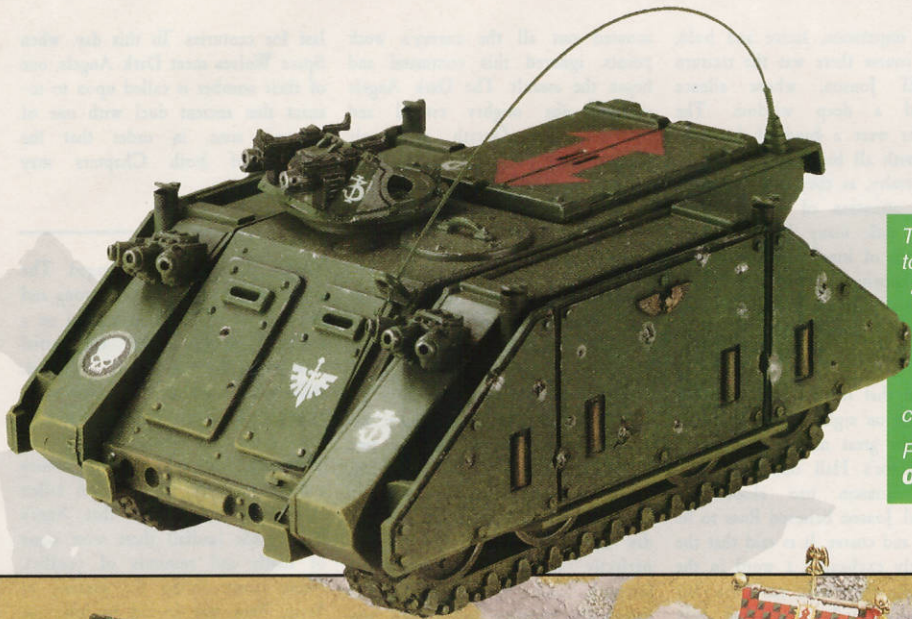

The parts that Mark used to make his ablative armoured Rhino are available separately from Mail Order. Why not give them a ring to find out about these and other exclusive components to help you convert your army!



Ring the Trolls on 0115 91 40000 for details.

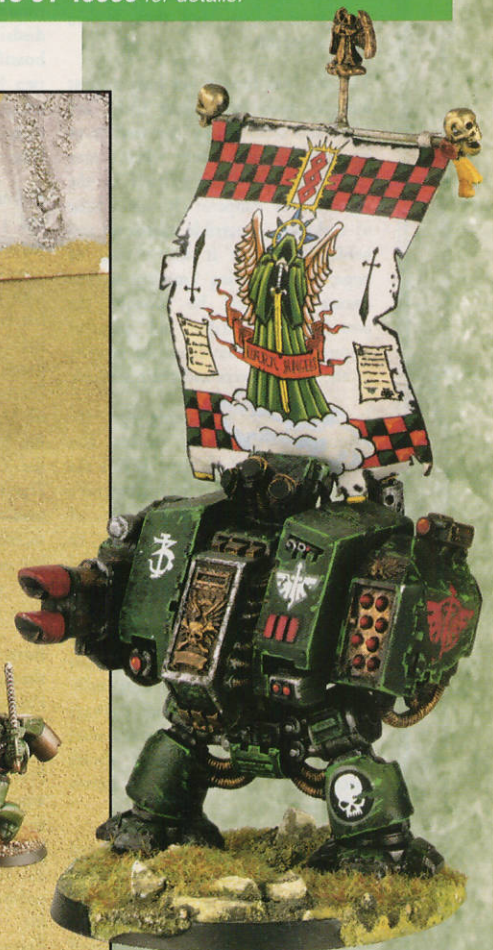

The Dreadnought above carries one of the fantastic banners that Mark has painted for the army.

+++++Date: 8941542/MII
+++++Ref: Astartes/0548766/DS
+++++By: Scribas Senioris Luthoris Rex
+++++Re: Histories of the Adeptus Astartes Vol.III,
Chapter 357, Subsection 95/W
+++++Thought: Purity is not your best defence, it is your only defence.

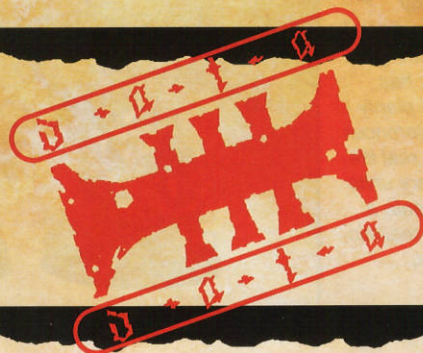

After the Emperor had found his lost sons, he set about reuniting the many kingdoms of Men. The Emperor's Legions raced outward, bringing the true faith to those who would listen and death to those who would not. Mighty wars raged; for there were many in those days who doubted the Emperor's word and turned their faces from his light. Some were honourable men, merely misguided. Some were tyrants and traitors greedy to retain their powers. And some listened to the whispered promises of Daemons and raised their warbanners against all humanity. The Space Marines fought an endless succession of foes and were undismayed, for they were mighty and their leaders were invincible.

The war was fought not only against renegade men but against Orks and Eldar and other beings too terrible to be named. It was a time when a man could win glory and respect in the sight of the Emperor. It was a time of darkness, of terrible massacres and noble deeds. But it was a time of hope; for the living Emperor walked among men, and he brought the promise of a stable and peaceful empire and freedom from the tyranny of the dark powers and their servants.

In this savage and noble age, the Primarchs walked the worlds like mortal gods. In those days, before the Fall, Horus was the Emperor's favoured son and the Lord of Humanity had every reason to be proud of him. He led the forces of Mankind to victory after victory. Noble he was and proud, respected and trusted by all. For he was the bravest of the brave and the mightiest of the mighty. His words were well-spoken and his opinions always reasoned and fair. His promises were always kept and his threats always enacted. He had never been beaten in battle.

Horus was always first among the Primarchs but there were others of near equal renown: Jhagatai Khan of the White scars, cunning master of the lightning raid; eagle-winged Sanguinius, of the keen eye and pure heart; Leman Russ of the Space

Wolves, impetuous, fierce and bold; and, of course there was the taciturn Lion El' Jonson, whose silence concealed a deep wisdom. The Primarchs were a band of brothers, and as with all brothers there was a certain rivalry, as they vied for glory and the attention of the Emperor. And as with many brothers there were bonds of kinship but there was also animosity. Sometimes feuds sprang up. The most famous and enduring of these was the one between Russ and Jonson.

It is said that the two men disliked each other on sight, when they first met in the great marble chamber in the Emperor's Hall on Terra. Russ thought Jonson too aloof and disdainful. Jonson believed Russ to be boastful and coarse. It is said that the two barely exchanged a word in the whole time they were on Terra, but then Jonson rarely spoke and only Russ took this personally.

If Jonson was quiet, he was also brave and a mighty leader of men. During the Great Crusade only he and Horus achieved a greater tally of victories than Russ. Russ, ever concerned with his honour and good name, and ever keen to tell the noble saga of his deeds, found this exasperating. Matters came to a head on the world of Dulan when the Dark Angels and the Space Wolves were set to assault the Crimson Fortress of the tyrant Durath. Durath had personally insulted the Emperor and had ritually sacrificed ten thousand believers to his patron Daemon in order to assure his victory. Both Primarchs were keen to claim his head.

Russ, ever headstrong, felt that he should lead the assault. Durath had claimed that Russ was the Emperor's puppy and that he would feed Russ's heart to his pet Grox. The Lord of Fenris was enraged and determined to wipe out this stain on his honour. He swore a mighty oath that he would personally slay Durath and cut out his heart. So angry was he that he ordered Jonson to stand down and let his forces attack the Crimson Fortress headlong. Jonson, who had spent days laying plans for his assault, and who had personally

scouted out all the enemy's weak points, ignored this command and began the assault. The Dark Angels stormed the mighty citadel and Jonson killed Durath in single combat on the keep's walls. Russ, caught in the swirling melee at the foot of the battlements, could only look on and howl with frustrated rage.

So great was his anger that when the battle was over and Jonson sat in triumph within Durath's Hall, Russ walked up and struck the Dark Angels Primarch. Jonson rose to his feet and struck back. A space was cleared in the great hall and the two Primarchs wrestled back and forth while their assembled men watched and shouted encouragement. For a day and a night they fought, each perfectly matched in superhuman strength and speed. Russ was marginally stronger but Jonson was slightly quicker, and so the two were evenly balanced.

Both had been schooled in hand-to-hand combat by the Emperor and by Warmaster Horus. Each knew every trick and feint. The fight rolled on out of the Hall and across the battlements. After a full day had passed they eyed each other warily over the shattered ruins of Durath's Fortress. Russ, quick to rage but quick to mirth, saw the funny side of what had happened and began to laugh. As far as he was concerned the right was over, both men had taken each other's measure, and honour was satisfied.

Jonson was not amused; he was slow to anger and slow to forgive and he saw Russ's first blow as treacherous. As Russ laughed, Jonson walked up and struck him unconscious. The prone form of Russ was carried from the Fortress by his men while the Dark Angels looked on and jeered. Now Jonson considered honour satisfied.

When Russ awoke the Dark Angels were gone, summoned by the Emperor to take part in the Alisore campaign. Russ swore that he would have vengeance on Jonson for his low blow. Thus began a feud that was to

last for centuries. To this day, when Space Wolves meet Dark Angels, one of their number is called upon to re-enact this ancient duel with one of Jonson's sons, in order that the honour of both Chapters may be satisfied.

Across the galaxy, war raged. The followers of Horus waxed strong and the balefire of rebellion burned on a thousand worlds. After the initial treachery of the Space Marines, millions of warriors followed their example and fought under the sign of the Eye, the symbol of the Warmaster. Imperial Guard armies and entire Titan Legions had fallen into error. Everywhere that Russ's ships made landfall there were signs of battle and rumours of conflict. Many times during the journey to Terra, Russ was forced to intervene in battles between loyalist troops and heretics.

On Tallarn, huge armies of men and Titans were locked in battle. The entire factory city of Rogsburg, a hundred miles across, was the scene of a vast slaughter. Russ paused to relieve the defenders of Rogsburg. As the city crumbled he stood in the centre of the Imperial lines and toppled an oncoming Death Skull Warlord Titan into the dust, leaping from the window of a skyscraping tower onto the machine's huge armoured shoulder and from there striking its death blow... Even a mighty Titan was no match for Russ in his rage. Having relieved Tallarn, Russ raced onward, back to the heart of the Imperium.

On the ice world of Thor V, he rescued ten brothers of the Adeptus Mechanicus from Snow Daemons besieging their base. The brothers, the only survivors of their unit, agreed to join Russ in his quest. Knowing they would not survive the journey unless they learned to fight as well as his men, Russ gifted them with the gene-seed and assigned his warriors to teach them. The leader of the Mechanicus, Brother Hrothgar, swore fealty to Russ and so became the first Iron Priest.

On Kalidus Jonson and Russ once more came to blows over who should lead the expedition. Jonson wanted to continue directly on to Terra while Russ believed it necessary to destroy the orbital fortress on Kalida Secundus, an armoured moon that bombarded the loyalist forces on the planet below. Tarus, a survivor who had fled the fortress, claimed the crew were possessed by Daemons. For a day the Primarchs argued and finally came to blows. This time they drew blades and went for each other. Russ gashed Jonson's cheek with his chainsword. Jonson tore Russ's arm. Their fight was stopped when Brother Hrothgar uncovered Tarus, showing him to be a mind-controlling Daemon in the shape of a man. Once the Daemon had been exposed, the inexplicable rage fell away from the Primarchs and they decided the duel was a draw. But both now harboured bitter resentments against the other. A joint attack was launched against the Secundus fortress. In the airless corridors the Space Marines fought against the mutated horde. Russ himself placed explosive charges in the reactor and the Space Marines retreated, departing in their ships, leaving the citadel of Daemons to explode behind them. The inhabitants of the planet at first thought a second sun had been born above them and cringed in terror, then, realising that the bombardment had stopped, they gave thanks to the Emperor.

In Lemora, the Chapters were assaulted by a fleet of pirates, reavers who had used the outbreak of the Heresy to pillage and loot, just as had happened before the Emperor established his peace. In the battle that followed, many ships were lost before the pirates were overcome. After defeating the corsair leader, Ghoran the Navigator, in single combat, Russ spared the man's life, then forced him to swear loyalty to the Emperor. Ghoran did so and afterwards he and his men fought bravely against the heretics. Ghoran's grandson was later to repay his forbear's debt most honourably. On the Shield Worlds Russ and Jonson defeated the Tyrant Mashashi and his army of ten million blood drinking men. From him they learned of the great assault that was planned on Earth. Mashashi was a sorcerer and a seer and even as he died, blood bubbling from his lips, his ribcage ruined by a sweep of Russ's axe, he sneered at his victorious foes and told them that all their efforts would be in vain. The Emperor would die, slain by Warmaster Horus.

Looking into Mashashi's great viewing crystal, the two Primarchs saw a terrible scene. In a place of

utter Chaos, the Emperor stood alone against the hideously changed Warmaster. Their brother Sanguinius already lay dead at the great evil one's feet. Russ and Jonson were deeply disturbed by Mashashi's prophesy. Both realised that it might be a trap set by the Dark Powers but both feared the worst, for the crystal of seeing was an ancient artifact of great power and was said to infallibly reveal the hidden secrets of the universe. The two Primarchs debated the course they should take. Within the crystal they saw the great fleets of the heretics voyaging towards Earth. They saw five entire Chapters of corrupted Space Marines, depraved spawn of Chaos and even Daemons descend towards the Imperium's heart. They decided that they must reach Earth, whatever the risk, and take part in this battle even if it was their last. They decided to use the crystal to guide them on the last, long warp voyage.

Gathering their men and ships the Primarchs led them into the warp. It was to be the longest single journey ever attempted at that time and it appeared doomed from the very start. Within the vast seas of warp space they were assaulted by Daemons who tried to prevent them reaching Terra. Many brave Space Marines and proud ships were lost. Great storms, sent by the Chaos powers themselves, swept them off course and drove them to the many shadowy corners of the universe unseen by men before or since. Brave men went mad, or starved or died of hideous plagues, but still the ships drove on, ploughing through that terrible, secret sea. In the end, with Russ himself at the helm of the Winter Wolf, his navigator driven insane from the horrors he had witnessed on the long journey, the fleet arrived too late.

Time flows strangely in warp space, and though it seemed to the ships' crew that they had travelled only for weeks, long and hard weeks though they may have been, in the true universe of matter many months had passed. The Space Wolves and the Dark Angels arrived on Earth to find the ultimate tragedy come to pass. The Ruins of Earth.

The Space Wolves and the Dark Angels dropped into the fighting around the ruins of the Emperor's Palace. Joining forces with the remnants of the White Scars and the Blood Angels they swiftly drove the forces of Chaos from the rubble. Howling his warcry, Russ battled his way into his father's throne-room, slaying every enemy that came within range of his bolter or within reach of his axe. By his side were his wolves, guarding his back, howling warnings of hidden enemies and lamentations

for fallen brothers. Through the shadowy halls Russ battled and one by one his bodyguards fell away, slain by their fearsome foes. Russ feared not. There were monsters in the most sacred hall in the Universe and Russ vowed he would slay every one of them if need be.

Two-headed mutants fell to his blade. Great formless spawn erupted and these he flamed. Daemons stalked the halls, howling in terror, for the Emperor had slain Horus and in turn had taken a mortal wound. Russ showed no foe mercy. Hatred was in heart and death was in his hand.

Russ came at last to the audience chamber. Fallen stone angels lay on the marble floor. The bodies of dead men and monsters were strewn everywhere. Over everything lay an eerie quiet and even the great wolves fell silent. Russ called aloud for the Emperor and his cry echoed, answerless, round the great chamber. He stood alone, at the centre of the world, and wept. He knelt before the Emperor's empty throne and prayed for guidance. In the distance, brazen horns sounded their victorious note. Word of the death of Horus and the arrival of Russ and Jonson had spread and the forces of Chaos fled in full retreat. The dark will that had bound them was gone. For the first time Russ felt no joy in victory and saw no glory in his deeds. In the empty hall, all seemed meaningless and dark, and despair threatened to overtake him.

The air shimmered and Rogal Dorn, stern Primarch of the Imperial Fists appeared. In his arms he carried the broken body of the Emperor. Behind him his men reverently carried the corpse of eagle-winged Sanguinius. He would fly no more. Russ looked wearily at Dorn. Silently Dorn shook his head. Both men knew that it was over. Horus's treachery had left the Imperium in ruins. The band of brothers was sundered forever. The dream that they had fought for was dead. This was no victory. Russ let out a great howl of grief and rage, and turned and stalked from the Hall.

Jonson found him under the Monument to the Victory at Durath. He too had taken the Emperor's loss most grievously. He too was maddened with pain and heartbreak and despair. In that darkest hour, bitter words were spoken. Jonson accused Russ of losing Earth. If they had not paused at Kalida Secundus they might have arrived in time. Jonson raged. Russ stared back mutely, then told the Dark Angels Primarch to go away. He had no thirst for battle. He lay down to sleep under the fallen statue to meaningless victory.

As he slept, he dreamed. As he dreamed the Emperor came to him. Russ was filled with wonder. The Emperor spoke, telling him that now was the time of testing. Now it was up to him and his true brothers to hold the Imperium together lest all that they had accomplished vanish. He told him that the matter between himself and Jonson must be settled finally and forever. When Russ woke Jonson stood over him, armoured and armed for a duel. Russ rose to his feet. He saw the folly of what was about to happen. The realm of Mankind was going to fall into anarchy, chaos and darkness, and those who could prevent it were fighting among themselves. He looked at Jonson and shook his head. Filled with rage Jonson insisted he fight. Russ simply exposed his chest, offering his heart to Jonson's blade. Jonson struck, but at the last second he perceived his madness. As the blade pierced Russ's primary heart, Jonson turned his stroke aside, deflecting the blade from bone, and missing the second heart. The duel was settled. Honour was satisfied at last.

When Russ awoke he found Dorn and Jonson standing over his bed. Jonson bowed his head and begged forgiveness. Russ gave it. Dorn told the Lord of Fenris of the construction of the Golden Throne by the Adeptus Mechanicus, that would preserve some spark of the Emperor's life until perhaps a cure could be found. The three of them swore a great oath never to do battle against each other again. For the universe had grown dark and Daemons were still at large and the true Space Marines were the last bulwark of mankind against ultimate destruction. They strode forth to reunite the shattered Imperium under the Emperor's banner. They drove the forces of Chaos back to the Eye of Terror. They fought many battles, for there was a galaxy to conquer. They banded together with the remaining loyal Primarchs and re-established order. Thus was the Imperium preserved and the Law maintained in the Universe. But the Emperor was lost and the Golden Age was over forever.



DARK ANGELS®



Deathwing Terminators

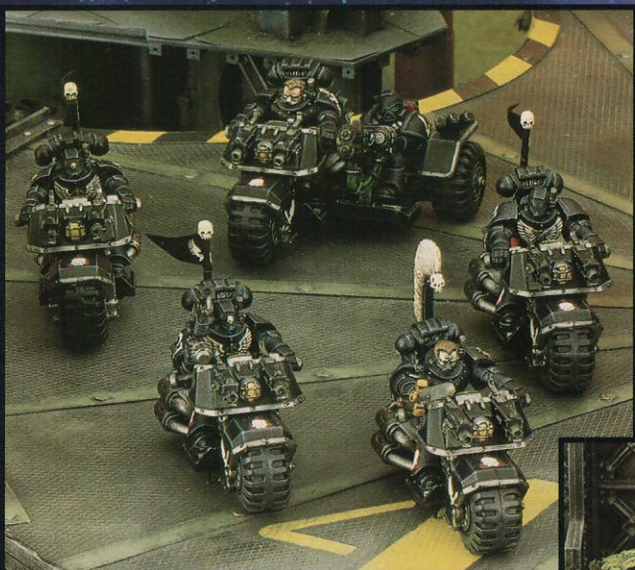

Ravenwing bike squadron

"Almost uniquely amongst the Space Marine Chapters, the Dark Angels have no home world. Instead their base of operations is a huge space-borne fortress known simply as 'the Rock'.

Once an asteroid, the Rock has been mined and converted into a space craft of truly gargantuan proportions, dwarfing in size all other space-going vessels apart from the largest space hulks."



Ravenwing Land Speeders



A moment of laxity spawns a lifetime of heresy.

Never forget, never forgive.



Dark Angels Master



Dark Angels Assault squad



A Dark Angels Tactical squad, supported by a Vindicator, guards an entrance to an Imperial outpost.

Damnation is eternal.
All souls cry out for salvation.
There is no salvation without suffering.



Dark Angels Devastators and a Dreadnought lend long-range support to their Tactical brethren.



Dark Angels Scouts

WARHAMMER® 40,000

Space Marines are humanity's ultimate warriors, mankind's last bastion against the terrors of the galaxy. Equipped with the best arms and armour the Imperium has to offer. Space Marine armies are the Emperor's finest.

There is not
time for
peace.

No
respite.

No
forgiveness.

There is only
WAR!

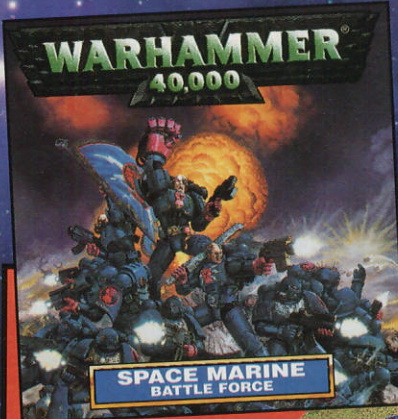

“NO RETREAT – NO SURRENDER!”
Space Marine boxed sets available now!

WARHAMMER

LIKE A RAT OUT OF HELL!

A Warhammer Battle Report

by Gareth Hamilton, Mike Walker and Iain Compton.

This is an unusual battle report in that it has been a long time since either Dwarfs or Skaven have been featured in a game, and the two armies taking part in this battle report are not 'Eavy Metal painted Games Workshop armies, but the personal armies of the two generals. Gareth, as you may remember from White Dwarf 230, built his army as an all-conquering tournament force, whilst Mike's Dwarfs are the result of many years of collecting and gaming in a club environment. Two very different armies, two very different generals, one very different battle!

Mike Walker is a popular contributor to our pages – over recent issues, he has given us his unique opinions on everything from new gamers to Lizardmen. Gareth Hamilton showed us his Skaven army in some detail in WD230 and is a highly experienced tournament player. What would happen when these two gamers, with very different backgrounds, faced off in a White Dwarf battle report? It seemed like a good idea to find out.

Before the players chose their armies, we told them who their opponent was and which army they would be facing. What we didn't tell them was the scenario that they would be playing. When designing their armies, they would have to come up with a force that was as flexible as possible. When the day came, I decided to arrange the table for a Break Through scenario. Even I am not nasty enough to force Dwarfs to outrun Skaven, so the Dwarfs would be defending a narrow valley from a rampaging Skaven horde.

The basic premise was that Bugman's Ultimate Response Patrol had been dispatched to protect a vital link in Bugman's burgeoning trade network. An entire village of their best customers was in imminent danger of being overrun by a marauding band of Skaven (who were hacking their way back to Skavenblight from some diabolic mission for the Council of Thirteen).

Determined to safeguard their profits, the Dwarfs had marched at full speed to head off the Skaven in a narrow valley, where the verminous horde would have to fight their way past if they were to continue onwards.

Would the Skaven break through the valiant Dwarf blockade or could the Dwarfs stem the tide of evil that threatened to engulf them? There was only one way to find out...



Choosing the Dwarfs

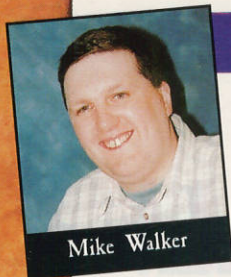

Mike Walker

Now, let me see, where did I put those excuses? Ah, here they are.

1. The reason that I lost was because I was inadvertently mesmerised by an early morning episode of Barney. Several million quite important brain cells, to save themselves from bright purple inanity, have self destructed. This has left me unable to formulate coherent thought.

2. The real Mike Walker has been replaced by the pod person you see before you. Although this creature devours meat pies in a similar way, it is unaware of even the most basic principles of Warhammer generalship and is incapable of making a single sensible move.

3. I spent far too long getting together a set of excuses to prepare a suitable battle strategy.

Being asked to participate in a battle report is a bit like being asked to replace the fifth Spice Girl. You are confident that you can carry the tune and jiggle, shimmy and kick in all the right places, but you spend all of your time worrying if, under the intense glare of the spotlights, you will look like a complete lemon in that little Union Jack dress.

Dwarfs were my first ever Warhammer army. For over a dozen years my Dwarfs have been tough, stubborn and slightly inebriated opponents for numerous Warhammer foes. They are always difficult to beat and are my most consistently successful army. I am confident of their abilities and believe that even under the added pressure of a battle report I can avoid any citrus fruit moments.

Paul Sawyer asked me about two months ago to play in this battle report. He told me to construct a three thousand point Dwarf army to take on a Skaven force. Naturally I was delighted and thought hard about my options. Normally I fight with a two thousand point army. The extra thousand points I have for the battle report will allow me to strengthen most of my existing regiments, give me a new cannon, add a unit of Hammerers and an extra Runesmith, and let me buy a couple of magical surprises for my opponent. Let's hope it works.

Having a weapon that can fire three feet across the table is a must for any figure that can only waddle three

inches forwards each turn. A Dwarf's inability to manoeuvre means that it is important to give the enemy an incentive to come to you. The powerful Strength 4 hits dealt by a crossbow fit the bill nicely. Most enemy units being peppered by a substantial number of crossbow bolts will want to close with the firers pretty quickly. Which is when a Brewer will get his mighty chopper¹ out.

The thing I like best about my Brewers is that they are versatile; they can spray the enemy with lethal crossbow fire and whack opponents with those massive cleavers in combat. This is why I have got nearly sixty of these excellent warriors in my army.

The two smaller units of Brewers will deploy ready to lay down a serious amount of firepower into the heart of the enemy army. Both of these units contain a Runesmith. With five *Spellbreaking Runes* between them, their primary job is to curtail the effectiveness of Skaven magic for as long as possible. Thorri's Horn with its *Master Rune of Dismay* is one of my magical surprises. I am hoping that its sounding will cause a pause in the rodent attack, allowing me an extra turn to rake the Children of the Horned One with missile fire. Bolli gets a *Rune of Stone* on his armour, mainly because I was five points short of three thousand when I totalled up my list. Both also carry crossbows so that they can add to the hail of fire heading ratward.

Dunk leads the largest unit of Brewers. Usually this gets deployed in position ready to fight, but I will wait until I know more about my opponent's force in case I need to set them up to contribute some extra crossbow shots. The unit has two *Runes of Battle* and a *Rune of Slowness* on their standard. The effect of this last Rune is to cause attacking units to lose D6 inches from the distance they charge. It doesn't always work, but when it does it can mean an extra round of shooting for the Brewers, disrupt a carefully co-ordinated attack by multiple enemy units or give the Brewers the opportunity to charge and allow Dunk to bash things first.

Dunk also carries a magical surprise for my pointy-nosed opponents – he has a throwing hammer adorned with the *Master Rune of Flying*. This unerringly accurate weapon will be used to thump any Warpfire Throwers that stray into range. At the beginning of a turn when his unit is likely to be charged, he will gulp down his *Potion*

Bugman's Ultimate Response Patrol



of *Strength*, giving him improved strength in the melee and the ability to chuck his hammer at the onrushing foe causing an automatic *Strength* 7 hit.

I am completely unable to give you any good tactical reason why I have included two bolt throwers in my selection. All I can tell you is that ever since their varnish has dried they have fought with Dug Bugman in his Ultimate Response Force, and that I am particularly proud of the conversion job I did on the master gunner in the pink floppy hat. They will be used to hurl bolts at any large (easy to hit) targets. If they inflict a bit of damage and annoy my opponent sufficiently, they probably won't be around for too long.

The cannon is brand new. Painted up specially for this battle. I wanted something that could do a bit of damage to any Daemon of the Horned Rat that happens to be wandering around the battlefield.

Another unit with fresh varnish are the Hammerers. Bought within a couple of weeks of their being advertised in *White Dwarf*, I finally completed applying the acrylic about two days before the battle. Two weeks to buy, two years to paint. About average for me. Led by Dug and with three *Runes of Battle* on their standard, these hammer-armed warriors mean business. I will require them to get stuck into my opponent's toughest unit.

Dug is my general, and over the course of our long association has become something of a talisman. I have never lost a battle with Dug on the table at its conclusion. This does of course mean that he has become a casualty quite often.

Dug loves to fight, and in this battle he is tooled up to take on tough opponents. His axe carries both the *Rune of Fury* (+1 Attack) and the *Rune of Cleaving* (+1 Strength). The *Rune of Spite* on his armour enables him to reflect any wounds he saves onto his hand-to-hand opponent and his three *Runes of Luck* will hopefully ensure that that the *Rune of Spite* works to its maximum potential. He will take on any special characters he comes across – even a Vermin Lord, after he has changed his trousers.

Ain't Slayers wonderful. For eleven points you get an almost naked Dwarf that waves two weapons about, is

scared of nobody and who can increase his *Strength* to match high *Toughness* opposition. Added to this unit are a Dragon Slayer leader and a Giant Slayer, plus a standard bearer. Another very tough unit, ready to take on the best the Skaven have to offer.

Finally I have selected a somewhat reluctant Gyrocopter pilot and his machine. The priority target for steam dousing is any Censer Bearers he can target. However his primary role will be to delay and obstruct the unclean host. This will first involve him flying close enough to the enemy to hamper their ability to march move. Should the brave fellow survive this then he may later be required to place himself and his craft directly in the path of charging Skaven, to disrupt an attack. A suitable burial site has already been chosen in which to place anything of him that remains.

Well that's the army sorted out and we are now just about ready to start.

Dug has given his before-battle speech, explaining to his outraged troops that most Skaven would rather drink out of a muddy puddle than sip a mug of Bugman's brew. Whipped up into a suitable battle-rage, his warriors are spoiling for a fight.

Now it is up to me. I must admit to being more than a bit nervous. But with a full day of *Warhammer* in prospect, playing my favourite army against beautifully painted opposition, on excellent terrain – it just doesn't get any better than this!

Right, let's exterminate some Vermin.

Mike

!No, not the ungainly, orange bicycle that was popular in the seventies. Nor what might be causing Carry On film fans a little snigger. This is the Brewers' large weapon, that requires both hands to wield effectively.

Mike's army features three generations of Bugman's troopers. On the far right are the original Bugman's Dwarf Rangers from so long ago that they don't even have slottabases! Second from left are the next incarnation of the Brewers, while to their right are the latest versions of these doughty warriors.



The Skaven Plan

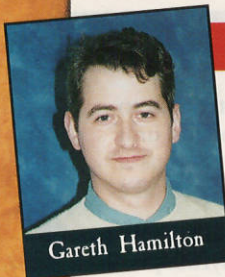

Gareth Hamilton

For me this is an ambition realised. Ever since battle reports started appearing in White Dwarf I have enjoyed reading them. How other generals choose and command their forces is fascinating to me, and as I read a battle report I'll often think to myself "I would have chosen that army differently or positioned this unit here or changed that unit."

Now it is my turn to put my prowess as a Warhammer general on public display, so I had better get it right!

First thing first; choose an army. I always start with my Warlord, Ratarsed Rat, who is equipped with *Skavenbrew*, *Armour of Fortune* and the *Warpstone Amulet*. These have been his magic items since I first created him and I have no intention of changing them just because I happen to know I am fighting against Dwarfs. The *Warpstone Amulet* has never worked yet but I can't think of any better time for my luck to change than in the middle of a battle report!

Next comes a big unit of Clanrats with a Champion (to accept any challenges), and Army Standard Bearer with the *Dread Banner* (yes, you've guessed it, the old outnumbered by fear-causing creatures ploy!). Hidden in the unit will be two Assassins with instructions to pick on an Army Standard Bearer with a nasty Master Rune or tie up any characters wielding nasty Rune weapons.

With the acquisition of the new, plastic Skaven regiment, I now have a second Clanrat unit to field. At only 30 models it is perhaps a bit small, but with a bit of luck it might just hold together, especially if I have enough other threatening units for crossbowdwarfs to shoot at. This unit will include a Chieftain, Rasta Rat (nephew of Ratarsed), to bolster its fighting ability, and will be pushing the Screaming Bell.

Normally against Dwarfs you are better off fielding several low level wizards rather than one high one. After all, Dwarfs dispel on a 4+, regardless of level, and having several wizards allows you to save more Winds of Magic cards after each magic phase. However Skaven level 4 wizards are slightly different to other races in that a Grey Seer is as powerful a fighter as a Warlord, and has access to potent spells that lesser wizards cannot use. He also gets a good supply of warpstone and can be mounted on a Screaming Bell. The Screaming Bell provides good protection for a Grey Seer and gives him an extra Winds of Magic card each magic phase. This last point, along with the *Rod of Power*, will compensate for the fact that a single wizard can only save one magic card each turn.

This now gives me two very powerful units, but a third certainly wouldn't go amiss. This will come in the form of Basilus Bubonicus leading his Plague Monks and Censer Bearers. Equipped with a flail, Basilus gets six Strength 6 attacks in the first round of combat. Along with a *War Banner* and maximum rank bonus, this unit is capable of routing the strongest opposition.

With the core fighting units chosen I shall now go on to the other less powerful, but no less important, units. Firstly, Gutter Runners. When fighting a Dwarf army you are always going to be faced with a plethora of war machines, and the only troops in your army capable of quickly taking these out are Gutter Runners. Tooled up with extra weapons, throwing stars and light armour, these have been given instructions to sneak up on the enemy and neutralise war machines as quickly as possible. Oh, and not, repeat NOT, to run away.

I will take two units of Clan Moulder troops; a large unit of Giant Rats which I intend to send on a flanking manoeuvre, and a unit of three Rat Ogres which are to

Skaven Clan Rat-Fink

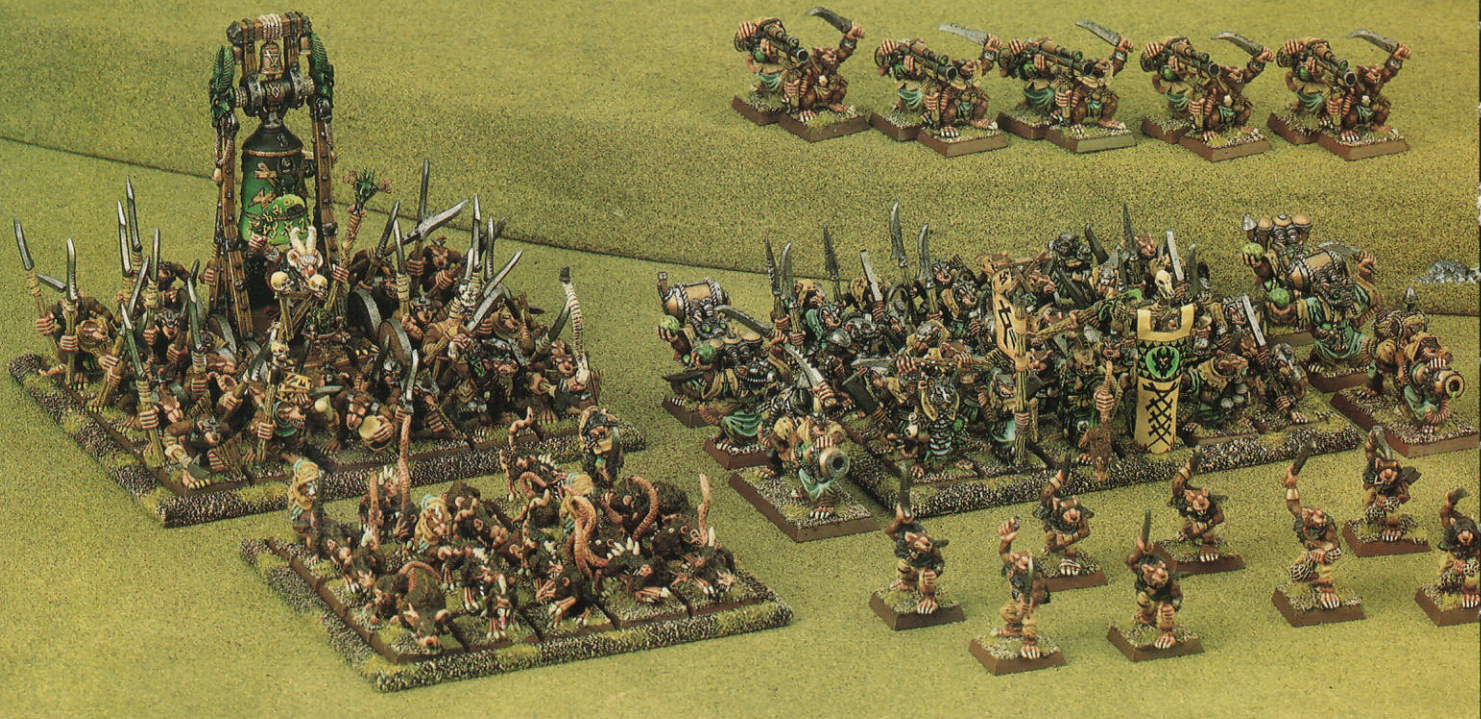

look threateningly at the crossbows in an attempt to draw missile fire away from my main units.

Next on the list is a small unit of Storm Vermin which have kindly volunteered to stay back and help protect against the Hainstock manoeuvre. The Hainstock manoeuvre is a tactic employed by a particularly ugly and foul smelling individual with a High Elf army at the Lincoln Games Club. It involves using Giant Eagles to land behind my units, thus preventing them from marching, whilst the rest of his army shoots my Clanrats to smithereens (Gyrocopters can perform this manoeuvre and shoot with steam cannons at the same time – scary!).

My second defence against the Hainstock manoeuvre is five Jezzails. Against Dwarves, Jezzails are next to useless as they have no choice targets except for Gyrocopters. This unit has been given instructions to shoot at any flying whirly things. Oh, and not, repeat NOT, to run away!

Lastly come the Clan Skryre wonder weapons. I will take both my Warfire Throwers and all four of my Poison Wind Globadiers. Where Jezzails fall down against Dwarves, Globadiers easily make it up. These weapons are perfect against large blocks of high Toughness, heavily armoured troops – which is exactly what you can expect to find in a Dwarf army.

Finally comes the Doomwheel, as terrifying for Skaven as it is for your opponent. This wonder weapon has been given instructions to keep away from anything with a tail.

G. Hamilton



The bulk of Gareth's army was shown off in White Dwarf 230. New for the battle report are some extra Clanrats in the unit which pushes the Screaming Bell – these are made from a second plastic Warhammer Regiment boxed set.

Deployment

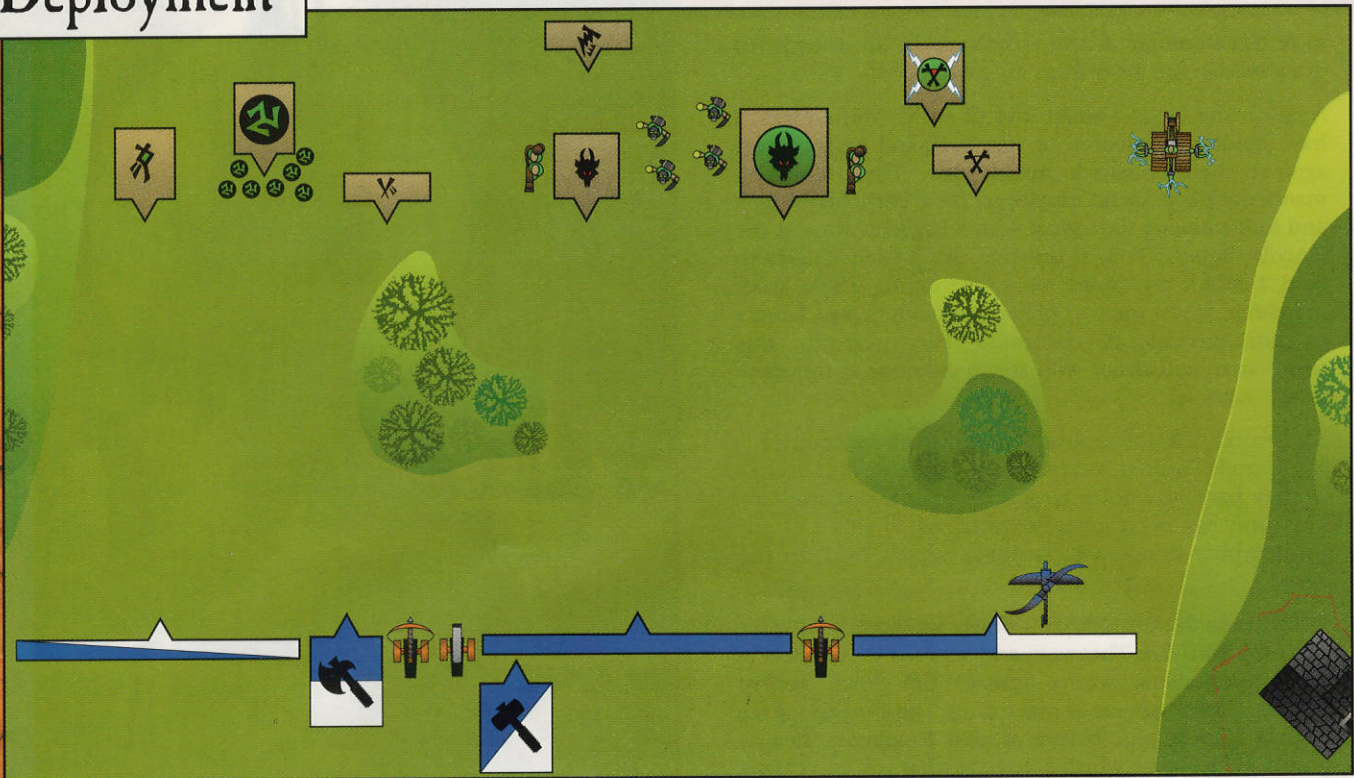

Dwarfs



Thorri's Brewers: 18 Crossbowdwarfs with double-handed weapons.



Dunk's Brewers: 22 Crossbowdwarfs with double-handed weapons.



Bolli's Brewers: 18 Crossbowdwarfs with double-handed weapons.



Slayers: 18 Troll Slayers with additional hand weapons. Led by Bart and Gorf Silverband.



Hammerers: 18 Hammerers with double-handed weapons. Led by Dug Bugman.



Gyrocopter.



Bolt Thrower.



Dwarf Cannon.

Skaven



8 Gutter Runners.



3 Rat Ogres with Packmaster.



5 Warplock Jezzails.



30 Clanrats with light armour, shields and spears. Led by Rasta Rat and pushing Screaming Bell.



33 Clanrats with light armour, shields and spears. Led by Ratarsed Rat. Unit contains Skitso the Battle Standard Bearer and two Assassins.



16 Stormvermin.



20 Giant Rats with 4 Packmasters.



19 Plague Monks with additional hand weapons. Led by Basilus Bubonicus. Unit carries War Banner and is accompanied by 6 Plague Censer Bearers.



Doomwheel.



Warfire Thrower.



Poison Wind Globadier.

The Scenario

In a Break Through, the attacker must try to get as many of his units off his opponent's table edge as possible. Each unit that escapes earns its points value in victory points for the attacker, and if three units escape then the attacker automatically wins!

We rolled to see how long the game would be and came up with a five turn game. I dealt Gareth his spells and he ended up with: *Scorch*, *Plague*, *Skitterleap* and *Pestilent Breath* along with four pieces of warpstone. Rather than use cardboard tokens to represent his warpstone, Gareth carries a bag of green jelly babies to battle! I suppose that this at least compensates for the chance of your Grey Seer turning into Chaos Spawn, although I suspect that it probably encourages you to be a little more reckless with your warpstone munching.

Gareth then rolled for his *Skavenbrew* and was extremely lucky to get a six. This is the best result possible for the Skaven – Gareth's main unit of Clanrats, with the Warlord and Army Standard Bearer, would double their Movement and Attacks! Finally, with all the other preamble out of the way, Mike won the roll for first turn and the battle began!

Dwarf Turn 1

With a loud whoosh of escaping steam and the unmistakable 'thwoppa thwoppa thwoppa' of rotor blades, the Gyrocopter lurched unsteadily into the air and chugged away toward the Skaven lines. The brave pilot had obviously already said goodbye to his family and given his watch to his best friend because he landed right in front of the Skaven army, just ahead of the Clanrats pushing the Screaming Bell. Mike was evidently sacrificing the Gyrocopter to buy the rest of the army valuable time. With the Gyrocopter so close, the majority of the Skaven army would not be able to march on its first turn, giving the Dwarfs another round of crossbow fire before the Skaven could get to grips with them.

At the other end of the table, the Slayers strode forwards towards the small wood, ready to hurl themselves at the

The brave Gyrocopter pilot single-handedly attempts to hold up the entire Skaven army.

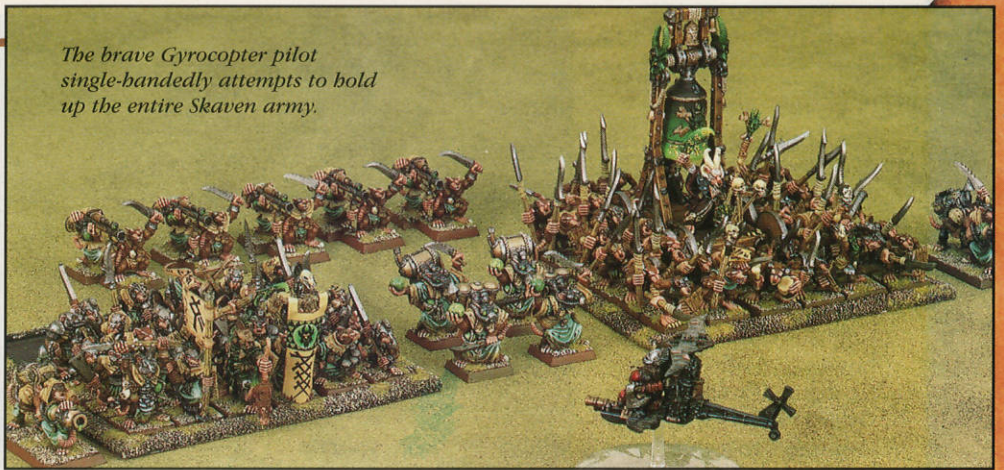

fast approaching Skaven, while shouting oaths and insults at the verminous ranks arrayed against them. With that, movement was over and the Dwarfs knocked quarrels to crossbows.

From the Skaven side it must have seemed totally daunting – the entire southern edge of the battlefield was a single, solid line of Dwarfs, all pointing things at them. First off, Thorri's unit of Brewers took careful aim at the Plague Censer Bearers across the valley. Despite the loose formation and the billowing sulphurous clouds surrounding each foaming, scabrous fanatic, the Dwarfs managed to fatally pierce three of them. The bolt thrower crew also managed to hit a Censer Bearer, but dazed by the pain and fumes, the leprous creature continued its advance oblivious to the three foot missile lodged in its vile body.

The entire centre of the Dwarf line held the Warlord's regiment in their sights. Destroying this unit was a priority. They were so dangerous due to the super-enhancing effect of the Skavenbrew that Mike simply couldn't allow them to reach him in any numbers. The cannon, Dunk's unit of Brewers, the second bolt thrower and half of Bolli's unit all sent a lethal shower of good Dwarven steel towards them, and succeeded in slaying seven of the supernaturally fast Skaven. Even at extreme range, the Dwarfs aim was proving deadly. Gareth must have been wondering whether any of his troops would actually reach the other side of the table. The Gyrocopter too gouted steam over a large part of the Warlord's unit, scalding five more to death where they stood. Despite the heavy death toll, Ratarsed Rat kept his verminous cohorts in line and their advance continued undaunted. Finally, those Brewers of Bolli's regiment that couldn't see the Clanrats loosed a hail of quarrels at the Doomwheel that was lumbering down the flank. But all the shots bounced harmlessly off its massive frame to no effect.

With no wizards, Mike's magic phase passed uneventfully and it was now the turn of the Skaven to reply to the Dwarf attack.

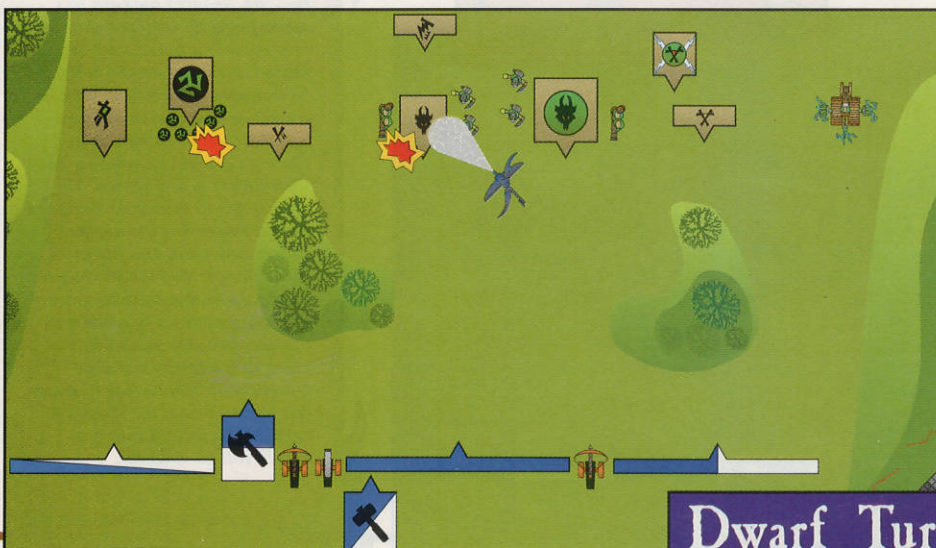

Dwarf Turn 1

Skaven Turn 1

The first thing that Gareth did was ring the Screaming Bell. The ominous peal rumbled across the valley but there was no discernable effect. The result that Gareth rolled only affected horses and cavalry figures. Obviously the Dwarfs were completely immune to this and simply looked bemused at the discordant noise. Determined to make up for the disappointing result of the Screaming Bell, the Clanrats pushing it declared a charge upon the isolated Gyrocopter, which prudently decided to retreat. The Dwarven machine easily evaded the huge block of Skaven, but the pilot was far from safe – his flight had taken him into plain view of the Jezzail teams behind the main Skaven battleline.



The Gyrocopter pilot escapes the Clanrats only to find himself in plain view of the Jezzail teams!



But there was another, far more important effect of the Gyrocopter's retreat. Now it was further away from the Skaven regiments, there was nothing close enough to prevent them from marching. Gareth wasn't going to pass up a chance like that, so the whole Skaven army, with the exception of the Jezzail teams who were busy aiming at the luckless Gyrocopter pilot, surged forwards at full speed (a staggering twenty inches in the case of the Warlord's regiment!). All five of the warpstone-laden shots smashed into the intricate machine. Although they weren't quite powerful enough to smash the workings, a lucky shot managed to kill the pilot instantly. The Gyrocopter spun wildly out of control before crashing harmlessly just behind the Skaven lines. As both the warpfire throwers had moved, neither

was able to fire, despite the fact that the one attached to the Warlord's regiment was alarmingly close the the Dwarf battleline.

The Winds of Magic raised barely a breeze and Mike, who had been dreading the Skaven magic phases, thought he might be able to hold off the Skaven spells for longer than he had hoped. Unfortunately Gareth had been dealt the Total Power card which he used to *Skitterleap* a solitary Clanrat from the Grey Seer's regiment directly into hand-to-hand combat with Dunk's Brewers. This meant that the unit counted as being in combat and wouldn't be able to fire their crossbows at the onrushing Skaven. At a stroke, about a third of the Dwarfish firepower had been neutralised. This use of the spell stirred up quite a debate (see 'Can you do That?' below) which we eventually resolved by dicing for it. Finally, the Grey Seer, well pleased with his cunning, stored two magic cards in his *Rod of Power* and the first Skaven turn was over.

Skaven Turn 1



Can You Do That?

Gareth Skitterleaped a Clanrat into combat with the Dwarf Brewers. Reading the card this seems perfectly OK, "the Grey Seer or a model within 6" may be moved anywhere on the table. If he is moved into combat then he counts as charging in the next turn." However on reflection, Clanrats are not allowed to leave their units for any reason. The spell seems to have been designed with transporting characters rather than rank and file in mind. We checked the Warhammer rulebooks and eventually resorted to rolling a D6 for it, when we still weren't able to decide. We came to the conclusion that Gareth could Skitterleap Clanrats but agreed that if the situation occurred in later games, we would roll for it again.

Dwarf Turn 2

With his Gyrocopter gone and the Skaven army almost upon him, Mike only had his Slayers to move. These wheeled to face the oncoming Plague Censer Bearers, ready to meet a glorious death against the servants of the Rat-Daemon. Everything else in the Dwarf army prepared to hurl all the firepower it could at the rapidly approaching Skaven.

Once more Thorri's Dwarfs let loose at the Censer Bearers but their aim was not as good as before, and only one fell, clutching the quarrel embedded in its chest. This was enough however to break their nerve and the insane warriors fled shrieking back towards their own table edge.

Due to the Grey Seer's *Skitterleap* spell, Dunk's regiment were tied up in combat, meaning that only the bolt throwers and the cannon could fire upon the chemically enhanced Clanrats. An over-long guess for the cannon and some poor sighting from the bolt

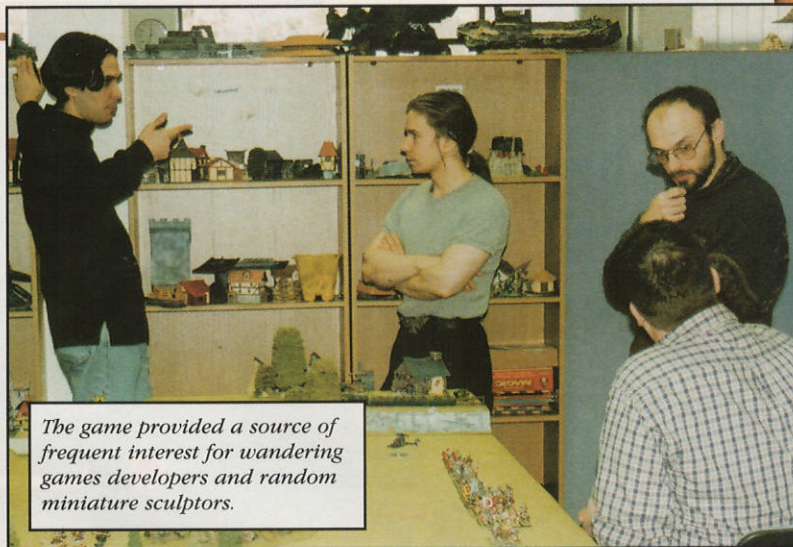

The game provided a source of frequent interest for wandering games developers and random miniature sculptors.

thrower crews combined to kill only one of the super fast Skaven. Meanwhile, far on the right flank, the majority of Bolli's unit unleashed a murderous volley at the Doomwheel. At such close range, they could hardly miss and the devastation they inflicted was certainly impressive. First the Warlock driver was killed, along with three of the rats powering the infernal machine; then a lucky shot damaged the steering, sending it careering wildly out of control – and with no driver there was no chance that Gareth could regain control either. The remainder of the unit, unable to see the Doomwheel, fired upon the Clanrats pushing the Screaming Bell, but only killed one.

In the first combat of the battle, the lone Clanrat sent to disrupt Dunk's brewers lashed out in a wild panic, scrabbling futilely against the solid bulk and chainmail armour of the Dwarfs. Dunk himself shouldered his way through the ranks and personally slaughtered the pathetic creature. Unfortunately for Mike, the damage had been done – the Skaven would be upon them in the next turn.

The Winds of Magic again blew weakly, and sensing perhaps that this would continue the Grey Seer decided to store three cards in his *Rod of Power*. Finally, in a last effort to hold back the verminous tide, Thorri Thortackle winded his horn emblazoned with the *Master Rune of Dismay*. Its brave note pealed across the battlefield and sowed doubt in the minds of the Skaven. The Gutter Runners, Rat Ogres, Giant Rat pack and the Jezzail teams were all transfixed by the clarion call and refused to move. This was small comfort to the Dwarfs however, as the most dangerous Skaven regiments were completely unaffected by the Rune, and were readying themselves for the charge...

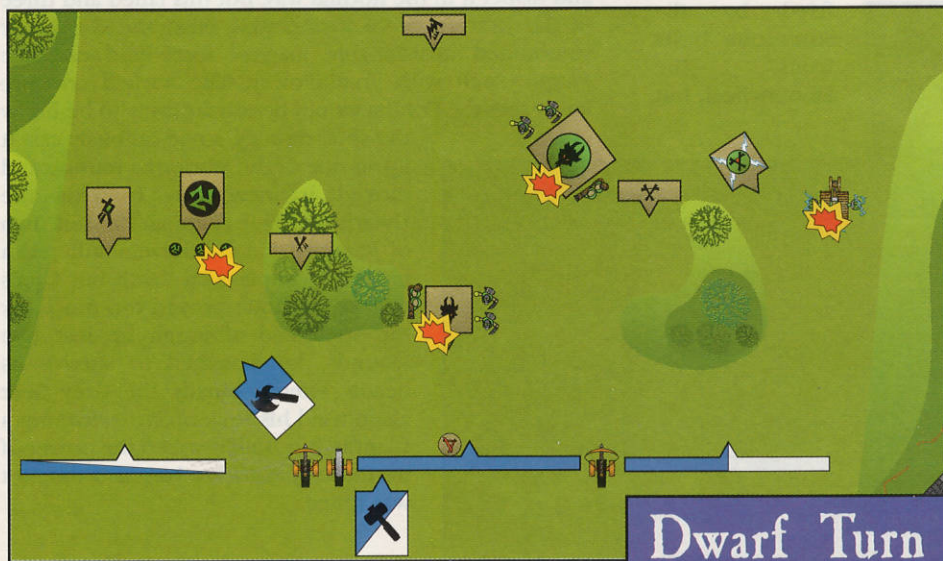

Dwarf Turn 2

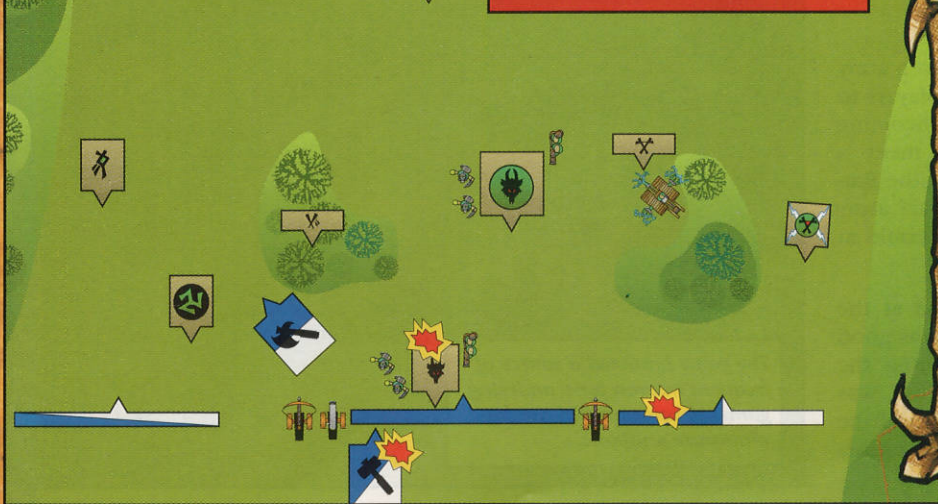

Can You Do That?
 Before the combat with the Brewers, Gareth's Poison Wind Globadiers lobbed their deadly missiles over the heads of the Crossbowdwarfs into the ranks of the Hammerer unit just beyond. This was another situation that required a rules adjudication. Tuomas Pirinen ruled that the letter of the rules applied here and as it says that you may place the Poison Wind template anywhere in range of the Globadiers, then Gareth could fire upon a unit that he couldn't see. This is a classic example of a unit having special rules that allow it, in some situations, to break the normal rules – players must decide exactly how far that exception extends. Luckily both Gareth and Mike believe in discussing potential problems in a reasonable manner.

Skaven Turn 2

Ratarsed Rat raised his halberd aloft, and with that signal the Skaven charged. The Warlord's regiment made straight for Dunk's Brewers and with their unbelievable charge range of 20" even the *Rune of Slowness* on the Brewer's banner could not keep them at bay. The Skaven Army Standard Bearer carried the Dread Banner but the Dwarfs stood their ground stolidly (even though the Skaven were too close to be able to stand and shoot at them).

By way of a change, not everything was going well for the Skaven. Firstly the Plague Censer Bearers failed to rally and continued off the table. Then the out of control Doomwheel swerved wildly off course and straight for the heart of the Skaven army, with warp lightning coruscating wildly off its projectors. Hurriedly the Stormvermin (in their coppery armour) scurried out of the way. The Rat Ogres however were not so lucky; although they were not hit by the machine itself, they were by far the closest unit and already the warp lightning was flaring towards them... The Screaming Bell's dread tone again pierced the battlefield and again there was no visible effect. The Dwarf engineers felt a tremor pass through the sturdy frames of their war machines but no damage ensued.

In the shooting phase, the Rat Ogres were fully expecting to be fried by the sorcerous bolts from the Doomwheel, but



Gareth can't believe his luck when he sees the hand he has been dealt!

much of its power had dissipated by the time it reached them, and apart from making their fur stand on end, it had no real effect on the hulking creatures. The Poisoned Wind Globadiers alongside the Warlord's unit lobbed their deadly spheres over the heads of Dunk's Brewers into the compact ranks of the Hammerers just beyond. Their aim was good and three of the Dwarfs fell, choking and gasping as they died.

Next was the hand-to-hand phase and Gareth was looking forward to it a lot more than Mike! Because of the *Skavenbrew*, every member of the Warlord's regiment would double his Attacks, and just as Mike thought it couldn't get any worse, two Assassins leapt out in place of the only two Clanrats in the front rank. This gave Gareth a monstrous 26 attacks with his character-laden front rank! By the time the Skaven had finished, no less than 13 proud Dwarfs had fallen and because the Skaven caused fear (due to the *Dread Banner*) and outnumbered them, they had no choice but to flee. Shrieking their victory chants, the Skaven pursued but allowed the broken Dwarfs to escape in favour of a new enemy – the Hammerers and Dug Bugman himself!

The Winds of Magic roared a veritable gale and the Dwarfs knew that they were in trouble. First the Grey Seer cast *Scorch* on Bolli's Brewers. The Runesmiths decided to save their precious *Runes of Spellbreaking* and dispel it in the normal way, but this failed and three of the Brewers were incinerated. Next the Grey Seer summoned unstoppable magical force and cast the *Plague* spell with Total Power. The wicked creature knew that the Dwarfs would be too far away to be hit by the spell directly, so he callously cast it upon one of the Warlord's retinue and moved it inexorably towards the Dwarfs and Dug Bugman himself. Two of Ratarsed Rat's followers suffered a hideously unpleasant death but Dug's mighty physique proved too much for the spell and although he lost two wounds, he managed to survive its deadly effects. Finally the Grey Seer again tried his trick of *Skitterleaping* a Clanrat, but Bolli invoked the power of his *Rune of Spellbreaking* and the plot was foiled.

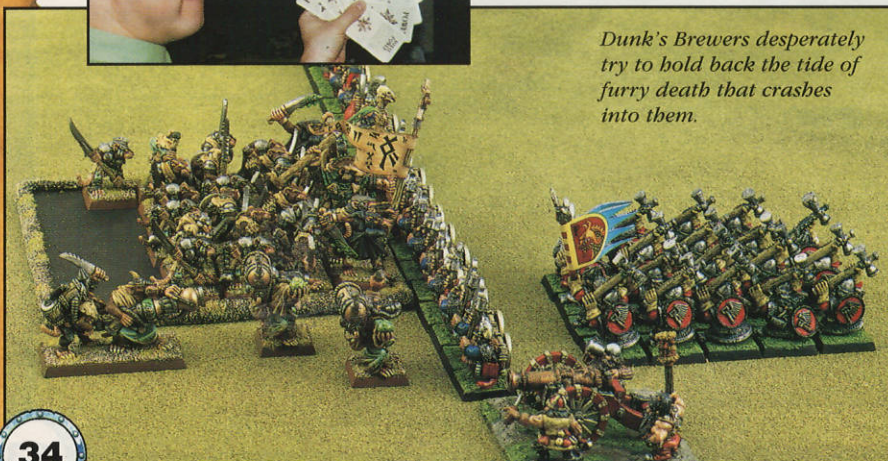

Dunk's Brewers desperately try to hold back the tide of furry death that crashes into them.

Dwarf Turn 3

Mike elected not to move anything this turn apart from Dunk's unit who rallied and reformed into a deep and narrow formation facing the Skaven. By now the Dwarfs were becoming increasingly demoralised and a very lacklustre display of marksmanship followed. Bolli's regiment again split their fire: some at the approaching Stormvermin and the rest at the Clanrats pushing the Screaming Bell, killing one from each unit. All the Dwarf war machines failed to kill anything: one bolt embedded itself harmlessly in the Screaming Bell's carriage, the other bolt thrower and the cannon sent their shots harmlessly over the heads of the Plague Monks. Thorri's regiment then loosed off a volley at the Plague Monks, but despite the nearness of their target, only three Skaven fell.

Now Ratarsed Rat was face-to-face with Dug Bugman and Dug had a score to settle! The two generals challenged each other and while the battle raged about them they fought for one thing – their enemy's head on a pole! Unluckily for Mike, Dug Bugman fell under the insidious effects of Ratarsed Rat's *Warpstone Amulet*, meaning that Dug would need to roll fives to hit and fours to wound, not disastrous but he really had his work cut out for him. The Skaven Warlord hit the sturdy Dwarf no less than six times but only wounded him once, Dug only had one wound left thanks to the *Plague* spell so if he failed to save, he would be dead. Luckily his *Master Rune of Spite* saved his life and he reflected the wound back onto the Skaven general. Unluckily every one of his own attacks missed completely, leaving the two generals still locked in single combat.

The rest of the Hammerers were not doing as well as their lord. Buoyed by their success against the Brewers in the previous turn, the Skaven felled five of the elite Dwarfs leaving



Dwarf Turn 3

none to fight back. Again the power of the *Dread Banner* came to the fore and the Hammerers, outnumbered and having lost combat against a fear-causing enemy, had to flee, taking the furious Dug Bugman with them. Alas their short legs could not carry them far enough and the victorious Clanrats overran them, and in the process escaped off the southern table edge. The first Skaven unit had broken through. Two more and Gareth would automatically win!

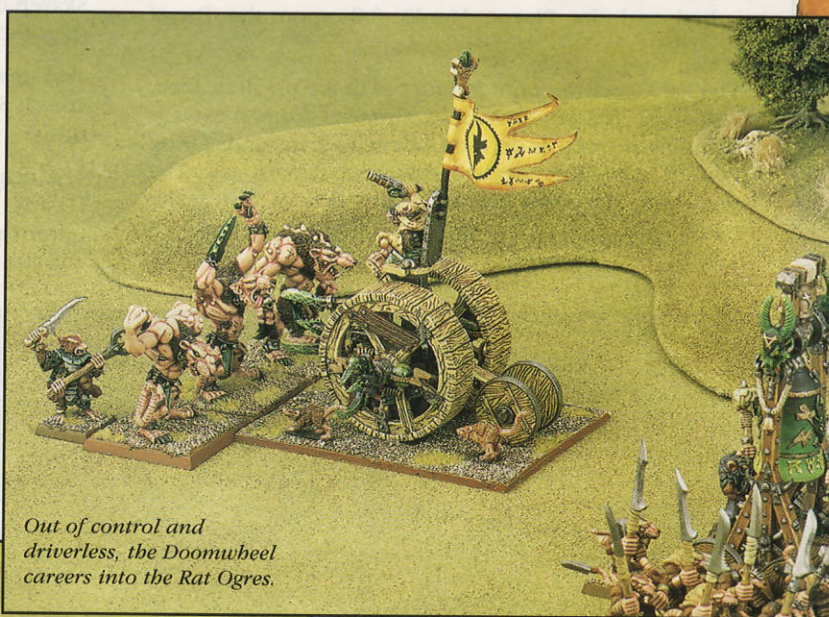

Out of control and driverless, the Doomwheeler careers into the Rat Ogres.

As the Brewers flee from the all-conquering Skaven, Ratarsed Rat leads his regiment straight into Dug Bugman.



The only stroke of luck that Mike had this turn was that the loss of his general did not cause panic amongst the rest of the ranks. Bugman's Ultimate Response Patrol squared their shoulders and prepared to die like Dwarfs.

Once more the Winds of Magic subsided to a brief murmur and the Grey Seer took the opportunity to recharge his *Rod of Power* with two magic cards.

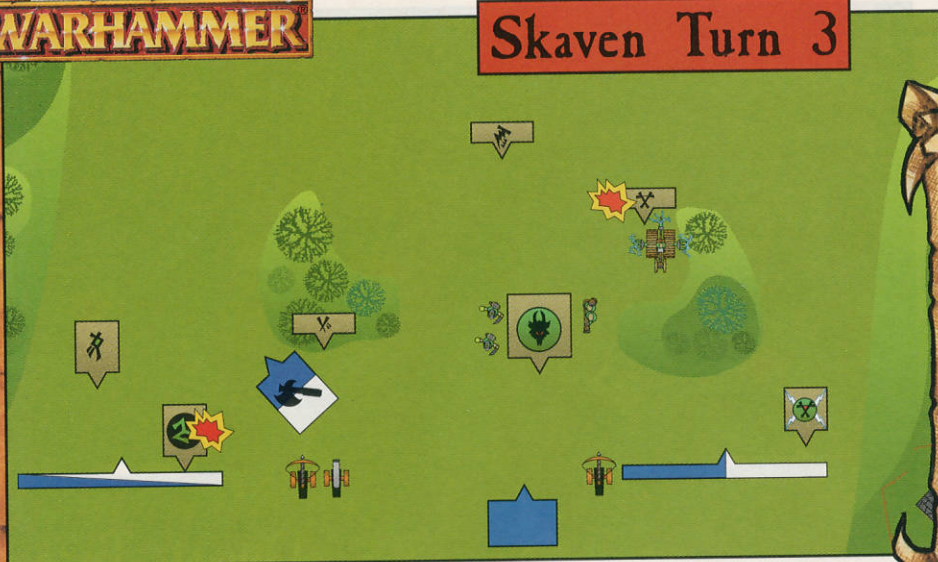

Can You Do That?

In his previous turn, Gareth cast the Plague spell upon his own troops to try to catch the Dwarf army in its effect. This threw up an interesting question; can you target an offensive spell on your own side? It seems a little like firing missile weapons into combat, hoping that some of the shots at least will hit the enemy. As with the other queries, the rules do not explicitly state one way or the other, so we chose to follow the view that if doesn't say you can't then you can. Also, it is definitely in the Skaven character to sacrifice their fellows in pursuit of their goals, so we agreed that this was a fair use of the spell.

Skaven Turn 3

The Screaming Bell sounded for a third turn and again without any noticeable effect, although if any of the Dwarfs had been trained as cavalymen then doubtless they would have regretted it. The rogue Doomwheel chose this moment to spin completely around and collide head on with the luckless Rat Ogres. Finally as the Plague Monks charged, Thorri's Dwarfs steadied their crossbows to try to drop as many of them as they could. Three fell but the verminous tide could not be halted and the Plague Monks fell upon the Dwarf Brewers.

The Rat Ogres were not as lucky as in the previous turn, and three full strength bolts streaked from the warp lightning projectors on the Doomwheel, instantly frying two of the great beasts and their Packmaster. The remaining Rat Ogre panicked and fled as fast as he could.

The only close combat was between the Plague Monks and Thorri's Dwarfs. The Plague Priest killed four Brewers but his followers were not so lucky and did not account for any more; in return, the only Dwarf left in base contact did well to kill a Plague Monk but the combat was lost. Thorri's nerve failed him and the Dwarfs fled. Just as with Dug's regiment before, the Skaven cut down every one of the Dwarfs before making their escape off the table edge.

Two down and one to go. Could Mike prevent the last, crucial Skaven unit from escaping in the remaining two turns?

The magic phase at least was a blessed change for the Dwarfs. The Grey Seer again tried to unleash a *Plague* upon the Dwarfs but Bolli used the Drain Magic card and the Winds of Magic suddenly ebbed away.



Basilus Bubonicus leads his demented followers into Thorri's Brewers.

Dwarf Turn 4

Things were looking bleak for the Dwarfs. If the Skaven broke through with just one more regiment then the game would be over. Trying desperately to block the Skaven advance, Bolli ordered his Dwarfs to move closer to the cliffs to cut off the Stormvermin's escape route, and Dunk's brewers reformed again, this time into a thin line extending across the table edge.

The Dwarf shooting this turn was short and appalling. Both bolt throwers missed their targets completely and the cannon overshot by a long way.

With no hand-to-hand combat to resolve, the turn was over bar the Grey Seer taking the opportunity to store yet more magical energy in his *Rod of Power*.

Skaven Turn 4

Upon the Screaming Bell, the striker summoned all of his strength and smote a mighty blow. With a deafening crash the sorcerous device shattered asunder, killing the striker instantly. The lethal harmonics also caused the

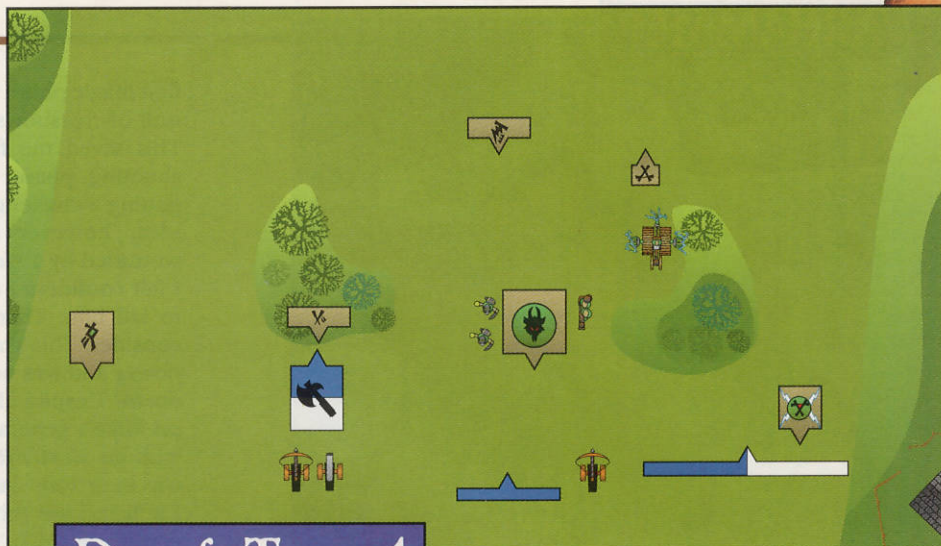

Dwarf Turn 4

brains of ten of the Clanrats pushing it to liquefy, along with those of two Giant Rats from the Doomwheel and a Poison Wind Globadier. Despite only being powered by one Giant Rat, the erratic progress of the Doomwheel was still fast enough for it to career wildly into a hapless Warpfire Thrower team, sowing yet more confusion into the Skaven ranks. The last Rat Ogre then routed completely off the table to add to the mayhem.

The Stormvermin, well away from all this self-inflicted carnage, charged Bolli's Brewers, who were too close to their foes to fire upon them as they came.

Warp lightning flared once more from the Doomwheel, this time upon the unfortunate warpfire thrower. Both the crew were killed instantly by the full power of the runaway machine. Further back, the Jezzail teams fired upon the cannon and its crew, but despite three of them finding their marks, no damage was inflicted.

The hand-to-hand phase was crucial this turn. If Bolli's Brewers could stop the Stormvermin, the game would be won or lost on victory points because no other Skaven units were close enough to the Dwarf table edge to achieve automatic victory. The Stormvermin however lived up to their reputation as hard-as-nails elites. Every one of them hit its target and three

Dwarfs were killed. The only surviving Dwarf in base-to-base contact missed and the Dwarfs had to pass a break test at a hefty minus 6. Alas, they failed and fled, the Stormvermin pursued and, pausing only briefly to massacre the panicked Dwarfs, made good their escape. The Skaven had achieved their victory conditions and the game was theirs. The shattered Dwarf army was powerless to prevent them from advancing victorious down the valley to the fertile plains beyond.



The Doomwheel continues to veer about wildly. This turn it rolls into an unfortunate Warpfire Thrower team.

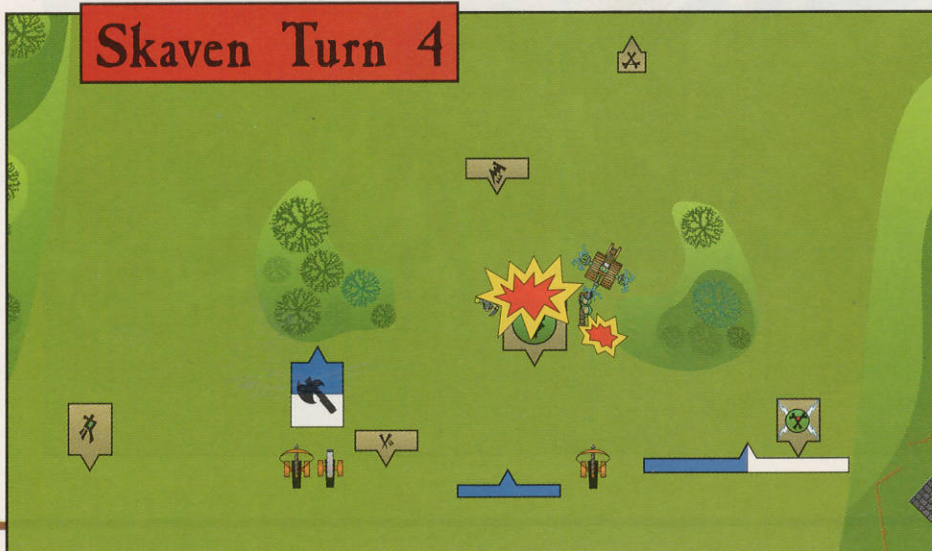

Skaven Turn 4

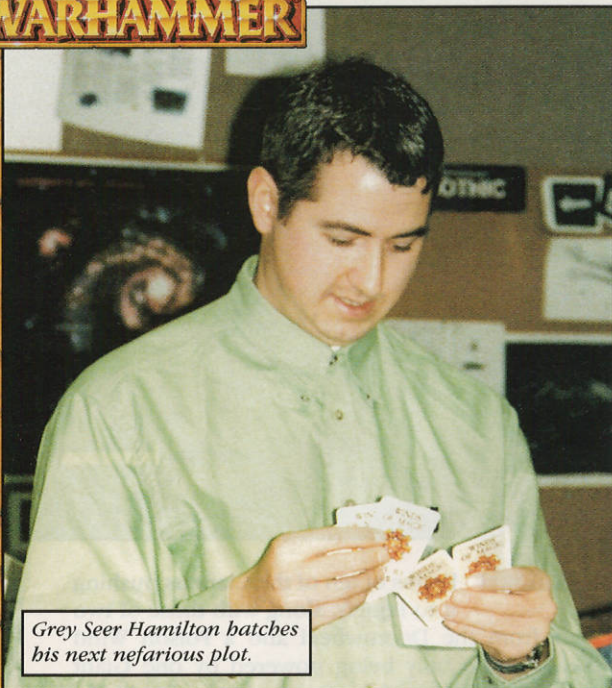

Grey Seer Hamilton hatches his next nefarious plot.

Gareth – How It All Went To Plan

Take that you stunties! A glorious victory for Ratarsed Rat and the Skaven. The Dwarfs were swept aside like cobwebs, powerless to halt the Children of the Horned Rat. But how was such a glorious victory achieved?

Firstly, to be fair to Mike, the Break Through scenario is difficult for Dwarfs as attackers or defenders. When attacking they do not have the speed to cross the battlefield in time. When defending, they need to deploy their forces wide, as they cannot move fast enough to cover any gaps the attacker may exploit. This was well demonstrated in this battle. Mike's long thin lines of crossbows were doomed the moment my forces attacked them in hand-to-hand combat.

I think Mike's biggest tactical mistake was in the use of his Slayer unit. Once my main Clanrat unit rolled a six for the *Skavenbrew*, the Slayers were probably the only unit in Mike's army that could halt them. If he had committed the Slayers from the start and moved them with all possible speed to intercept my supercharged Clanrat unit, he could have caught them in the flank and thus easily won the combat!

On a positive note for the Skaven, things just fell into place perfectly. After the good result on my *Skavenbrew* I received Total Power in my

first magic phase which enabled me to silence Mike's big unit of crossbows by *Skitterleaping* a Clanrat into them. This saved me from another mauling in the Dwarfs' shooting phase. Next came the challenge! Normally issuing a challenge with a Skaven Warlord is not a good idea, however Mike's general had been seriously wounded by a *Plague* and my Warlord had eight attacks! I felt confident I could cause the one wound I required to kill him. There was also that *Warpstone Amulet* to consider. This was to be its last chance to prove it had power and was not just a pretty trinket. It did not let me down! Despite all this I still only managed one wound on Mike's general which turned out to be fortuitous as with his *Master Rune of Spite* and three *Runes of Luck*, I was in serious danger of killing myself! The only wound I inflicted was rebounded of course. The final nail in the coffin for Mike's Dwarfs was probably his terrible shooting phase in the third turn. He failed to cause enough casualties on any of my units to force a Panic test!

My only disappointment was with the Clan Skryre's so-called wonder weapons. Once again the Doomwheel seemed intent in destroying my army by itself. I suppose those frenzied rats just like the company of their own kind. The Screaming Bell seemed happy to scare any horses that happened to be around, until it blew up with spectacular results. I should count myself lucky that I never had the opportunity to fire a warfire thrower!

Things are now looking good for Ratarsed Rat. The fortunes of Clan Rat-Fink are waxing. Seeing the potency of his Skavenbrew, the Council of Thirteen has bought sole rights to its supply and distribution, thus preventing any one clan from becoming over-dominant (much to the annoyance of Clan Pestilens). This big injection of cash will be used to buy those big regiments of slaves that have been missing for so long from his clan. Perhaps the mysterious Warlock who sold Ratarsed the *Warpstone Amulet* was not lying when he said that one day, with its power, Ratarsed would gain a seat on the Council of Thirteen!

Nice amulet, pretty amulet, POWERFUL AMULET!



The Stormvermin break through the Dwarf lines, winning the game for Gareth.

Mike – How It All Went Horribly Wrong

The best thing about this game was discovering, when it had ended, that there were still four 'warpstone' jelly babies to share.

I never won a single combat, my opponent was responsible for the death of more rat creatures than I was and spotted dick was unavailable from the sweet counter at lunch time. Not one of my better days.

Did I avoid any citrus fruit moments? Did I heck.

I singularly failed to get my Slayers into contact. They should have made directly for the Plague Monks from game start.

Apart from the first shot, the ranges I guessed for my cannon were about as accurate as an England penalty taker.

In hindsight, maybe I should have put the Gyrocopter and then Dunk (on his own) in the path of the *Skavenbrew*-powered Clanrat unit. This might have slowed it down a bit and given me a chance to take on the Skaven stuff I would have been able to stop.

For me the key moments of the battle were:

- Gareth rolling a six for the Clanrats with the *Skavenbrew*.
- The shooting down of the Gyrocopter.
- The *Skitterleaping* Clanrat (cast with Total Power, so no chance to dispel) attacking Dunk's unit.
- The fight between Dug and Ratarsed Rat: Dug failed

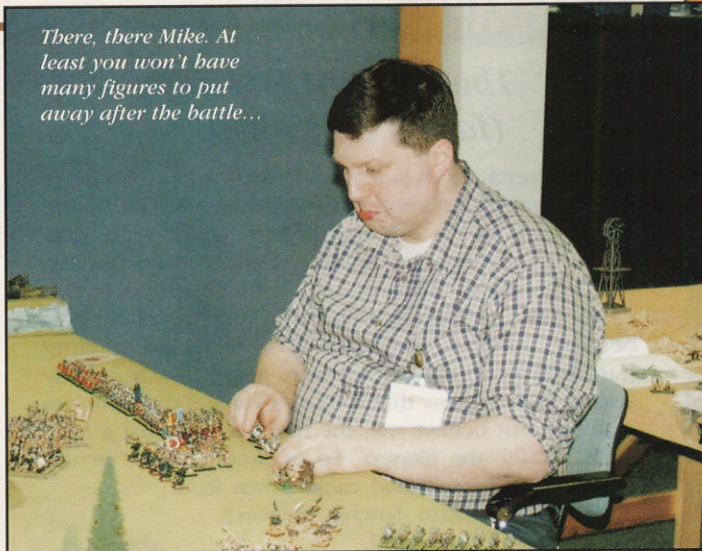
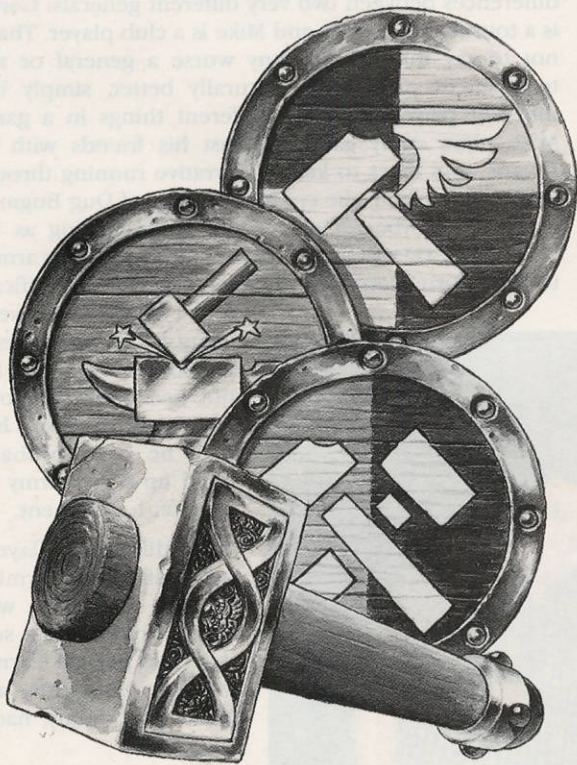

There, there Mike. At least you won't have many figures to put away after the battle...

to hit at all due to the *Warpstone Amulet* and Ratarsed did not fight well enough to kill himself with the *Master Rune of Spite*.

- The failure of the Dwarf Slayers to get into contact with the Plague Monks.

Opinions on how I could have improved army selection were numerous. Passing ex-world champions, highly skilled figure designers, current Studio champions, ex-staff champions and pie filled editors all had some advice to offer. Three items kept occurring on the lips of these 'experts'. I should have used two Gyrocopters to create more interference and reduce the number of Skaven march moves. A couple of flame cannons would have been good, as these flame-belching beasts are especially effective against large blocks of infantry. The third and last suggestion was a *Rune of Courage*, which is excellent for Dwarfs trying to hold a defensive position.

I think Dug will be looking to trade in some slightly soiled Hammerers for a number of these items in the near future.

Iain Compton did a great job organising the game. Gareth and I had a really good time fighting the battle. Gareth is a highly skilled general² and figure painter (his Warlord figure wielding a Giant Rat is superb), and a thoroughly nice bloke. The game was an excellent spectacle and played so smoothly that we finished it in under three hours (even with Iain having to draw a new map at the end of each move).

Despite getting comprehensively beaten, I had a brilliant time and enjoyed the day enormously.

I've got to go, someone has just handed me a dustpan and brush so I can clear up the remains of my army. And Mr Sawyer has arrived and wants to know why I lost so badly.

Now let me see, where did I put those excuses?

Ah, here they are...

¹I assume that if the Skaven general had died then the effect would have been a bit more pronounced than the usual Dwarf reaction of a small shrug, a quick 'tut' under the breath and a slight beard adjustment.

²Using the Plague spell on his own troops so that the disease could be transmitted to Dug, reveals that Gareth has a complete disregard for the well-being of his own troops. He is indeed a true Skaven Warlord!

The Voice of Reason (Iain's Comments)

This was certainly an entertaining battle to watch. In fact it was two entertaining battles. We started the battle report early in the morning as both Gareth and Mike were only going to be down at the Studio for the day. First time round Mike set up all of his Brewers in two ranks. We had played about four turns each when it became obvious that the Dwarfs were getting pummelled and the Skaven were going to win an easy victory. Now I know that sounds a lot like the game we featured, but believe me, the first one was just a total walkover for the Skaven. So at around three in the afternoon the command came down from on high (well Paul Sawyer anyway), "Play it again!" So we did.

Looking back on the battle from the cosy armchair of hindsight a number of points occur to me. Firstly, I think Mike could have used the Slayers better. They were the only unit that could have held up the Skaven Warlord's regiment. Rank bonus, pah! *Dread Banner*, pish! The Skaven would have had to kill every single one of the Slayers to get past them. Even with doubled attacks this would have taken a couple of turns at least, and maybe given the Hammerers enough time to manoeuvre into position for a flank charge. I reckon Mike should have planted the Slayers smack in the way of Ratarsed Rat.

Secondly, fleeing with the Gyrocopter was a bit of a waste of time. It was very unlikely to escape destruction anyway, and by fleeing, Mike gave up the whole point of moving the Gyrocopter to the front of the Skaven army in the first place. Once the Gyrocopter had fled, the Skaven army could happily march towards the Dwarfs. If

it had stayed, the Gyrocopter would probably have been destroyed (although it isn't by any means a foregone conclusion), but the Skaven army would have been slowed down for one more vital turn.

Finally, and perhaps most significantly, once combat was inevitable, i.e. when the Skaven got into charge range, Mike could have reformed his regiments into ranks to give them at least half a chance in the combat. Admittedly there still wasn't a lot that he could have done against the warpstone-frenzied Clanrats but certainly against the Stormvermin and the Plague Monks, he would have seriously improved his chances.

Still, it's easy to see what other people are doing wrong and I dare say that if I had been in Mike's shoes then I would probably have made many of the same mistakes, as well as discovering fresh new ways to mess up. From the other side of the table, rogue Doomwheels aside, the Skaven plan went beautifully. The Skaven won every combat that they fought, in the first turn of combat – not because the units were tooled up with super characters and beardy magic item combinations but because Gareth designed solid units that tipped the odds in his favour from the beginning.

Perhaps more than anything, this battle report shows the differences between two very different generals. Gareth is a tournament player and Mike is a club player. That is not to say that Mike is any worse a general or that tournament players are naturally better, simply that different players look for different things in a game. Mike plays many games against his friends with his Dwarfs, and loves to keep a narrative running through his army. For him, the continuing saga of Dug Bugman, Dunk Whiskeybeard etc. is just as interesting as the battle itself. Gareth on the other hand designs his armies to win tournaments. He draws up an army specifically for a particular event, using a very narrow set of guidelines. His army has not been collected over many years as Mike's has, and he will probably build up a new army for his next tournament.

Two different players, two different armies. While Gareth won convincingly, I am sure that both players learnt a lot from the battle, and more importantly, had a lot of fun.

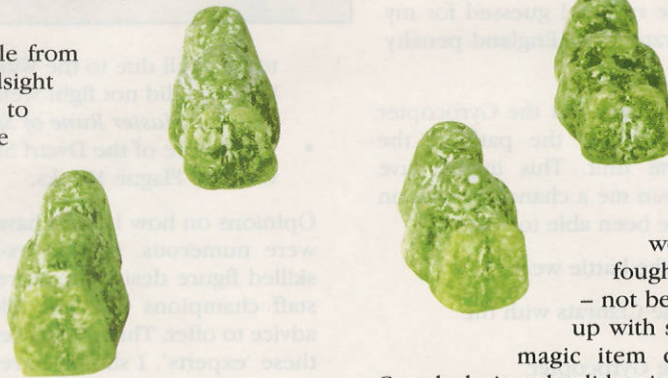

After a hard fought game, the two generals shake hands and begin to worry about writing up their conclusions.



GET A COMPLETE WARHAMMER CAMPAIGN!



A Black Library Publication

FEATURING...

Warhammer Campaign

Warwick Kinrade brings you a mammoth Skaven vs Empire campaign.

Beastmen in WHQuest

Full rules for using Beastmen in your games of Warhammer Quest

Deathbowl

An old favourite for Blood Bowl returns. Totally manic action with four teams, two pitches and two balls.

WH40K Campaign

More campaign action, this time for 40K players with 'The Siege of Herodopolis.'

INSIDE:

- Death Bowl
- Dok Butcha
- Gorka-Squigs
- Warwick's World

ALL THIS, PLUS LOADS MORE COOL STUFF!!

Did you know that every issue of the Citadel Journal is crammed full of loads of exciting articles, covering all aspects of the hobby – gaming, modelling, painting tips, scenarios, and much more – all written by gamers, for gamers!

AVAILABLE FROM ALL GAMES WORKSHOP STORES & MAIL ORDER

96 pages of hardcore hobby for only £4 – Out Now

A SECRET WAR

PURGATORY : 245141/M41

The Inquisitor walked through the burning rubble of the mining outpost, his rugged, bearded face set in an inscrutable frown. It was clear from his expression that the events which had taken place here bore terrible consequences for the Imperium. A squad of Ultramarines followed him over the battlefield, the proud Space Marines maintaining strict file order at all times. Every member of the squad, despite preserving his exterior impassive calm, looked on in horrified disbelief at the scene. The entire frontier fort had been razed to the ground; not a wall remained standing. The occasional corpse of a Chaos Space Marine lay in the ashes but they were far outnumbered by the butchered carcasses of frontiersmen and Cadian shock troops littering the ground.

What manner of warp-born atrocities had been committed here? Everything about the Chaos Space Marines sickened the Ultramarines to the core. The Night Lords, and those other heretics who had pledged their allegiance to the warband, were the total antithesis of the Emperor's loyal Chapters. They tore down that which once they had created and which the Ultramarines now strove to protect. They showed no remorse at wiping out the entire population of a planet and all because of some misguided, megalomaniacal notion that they had something better to replace it with, that they could better control.

Oh, how the Inquisitor lamented the weakness of the human condition. How could the Emperor's finest Space Marines have let themselves fall so far from the Emperor's saving grace. What was this dark power that could have caused the Ultramarines' brethren to become no better than wild animals, with all humanity gone?

Not a single soul remained alive, or free from eternal damnation, the Inquisitor noted mentally. There was no sign of the women and children. No doubt they were already chained within the bellies of the Night Lords' ships, bound for a life of slavery on one of the abominable Daemon worlds at the edge of the Eye of Terror.

The Inquisitor had long suspected that the Night Lords would eventually find their way to the world of Purgatory and when they did, all humanity would tremble before their traitorous plan. For buried beneath the surface of the planet was an artefact spoken of in hushed whispers and accompanied with warding gestures among the Ordo Malleus.

Through divination carried out by the psykers of the Inquisition, the doomsday weapon known only as the Hand of Darkness had been located on the small, forgotten world. Said to be a gift of the Dark Gods, sent into the physical universe straight from the heart of the Realm of Chaos, nothing was comparable to it in power; not even the planet-scouring process of the Exterminatus.

Sending tendrils of mental energy into the ether surrounding the planet, the Inquisitor sensed that something was missing from the heavily traumatised psychic aura of Purgatory. Something large, devastating and tainted with the corrupting power of the warp. He knew then that he was too late. The Night Lords, and a weapon with which whole star systems could be ransomed, were gone.

A scenario for Warhammer 40,000 by Jervis Johnson

Purgatory background story
by Jonathan Green

With the release of Codex Dark Angels, we wanted to do something a little bit different. Ever eager to venture into the unknown, Jervis has written a special scenario, with a heritage that older gamers may recognise. Over to Jerv...

This scenario pits a small force of Dark Angels against a Chaos Space Marine force led by one of the Chapter's most hated foes – the enigmatic and deadly Fallen Space Marine known only as Cypher. You can learn more about Cypher from the Fallen Angels article I wrote for WD231, but for the moment suffice to say that the Dark Angels are willing to do absolutely anything in order to capture this former member of their Chapter.

The scenario is in a rather different format to that normally used, and borrows some ideas from the Fighting Fantasy series of linked paragraph books with which I'm sure you are all familiar (as an aside, the series creators, Ian Livingstone and Steve Jackson, happen to have also been the original founders of Games Workshop, so I'm sure they won't mind me, erm, borrowing their ideas). Basically, each player in the scenario is given a briefing in the form of



a paragraph or three of text, at the end of which is a series of options. The players read their briefings and then secretly pick an option, and after both have chosen, the options are looked up on a special chart which will say what effect, if any, the players' choices have had on the scenario to be played. This may sound a little arcane, but don't worry, it's easy to use and really quite a lot of fun. It also allows the players to exercise some pre-battle strategy, which may effect their chances of winning the game.

IMPORTANT: In order for this system to work, it's vital that players don't study their opponent's briefing or the results chart before the battle takes place. Because of this, the briefings and chart are located in different parts of this issue of White Dwarf. At the end of this introduction you'll be told which page to turn to in order to read the briefing for your army.

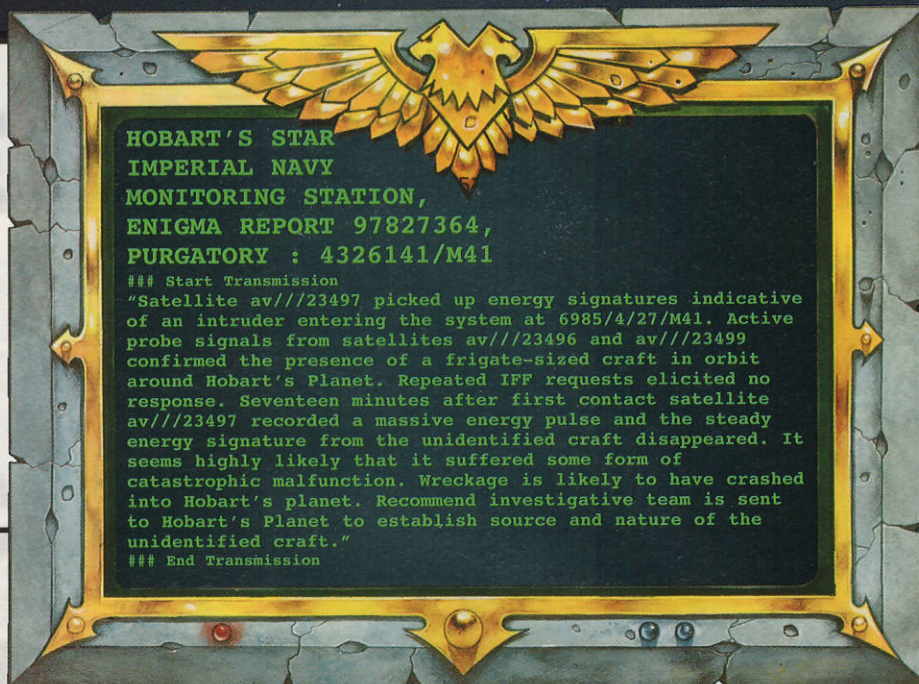

WHAT YOU WILL NEED IN ORDER TO PLAY

- Warhammer 40,000 rulebook
- Codex Chaos
- Codex Dark Angels
- Cypher
- Two Imperial Guard squads

In addition to the above you'll need a Dark Angels army and a Chaos Space Marine army chosen from the standard force organisation charts. These armies can be of any size (as long as both are the same!) but around about 1,000-1,500 points will be best. The Dark Angels army must include an Interrogator Chaplain. The Chaos army must include Cypher, but may not include any other Fallen Angels. Cypher does not cost any points, but he uses up one of the army's HQ unit slots (note that in this scenario Cypher counts as an HQ unit and leads the army in place of a Chaos Lord or Daemon Prince).

Don't forget that as there are a myriad of possible outcomes for battles, depending on your choices, this scenario can be played over and over again!

STOP!

You have read the general briefing for both players.

If you will be commanding the Dark Angels in the scenario, read only the brief on page 44.

If you will be commanding Cypher and the Chaos Space Marine force, read only the brief on 45.

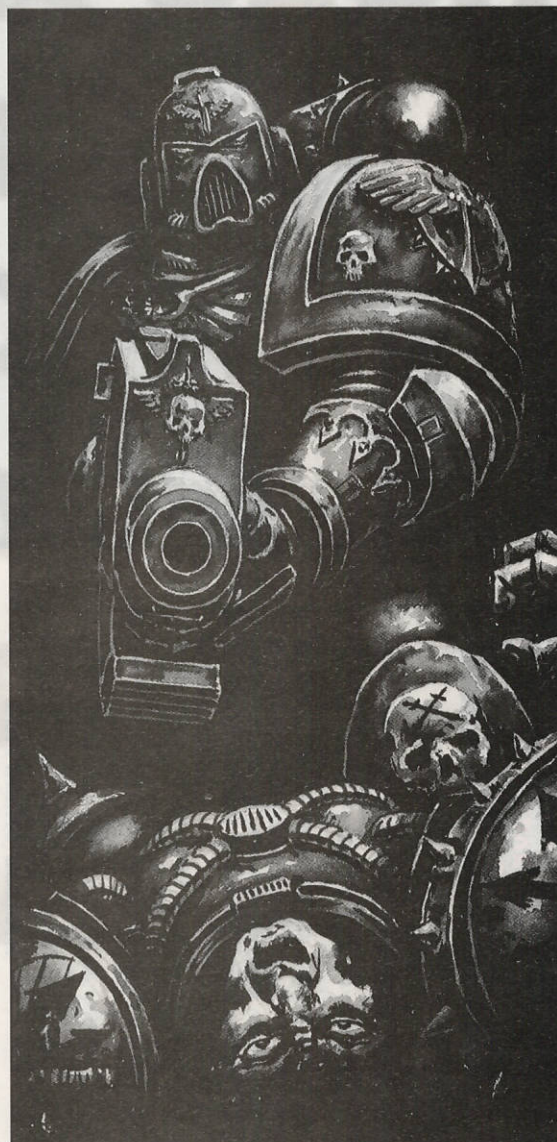

A SECRET WAR DARK ANGELS BRIEFING

A SECRET WAR DARK ANGELS BRIEFING

Following a request from the High Council, one year ago the Dark Angels' space-faring fortress monastery – known as the Hock after its asteroid-like appearance – relocated to this sector of the galaxy.

You and the small force of brother Space Marines from the Dark Angels Chapter that are under your command have been following a trail of rumours and circumstantial evidence, which indicate that Cypher, most hated of your Chapter's secret enemies, may be at large in the sub-sector to which you've been assigned as guardians. If there is even the tiniest chance to capture this arch-heretic then you must take it. The honour of your Chapter may depend on your actions!

The trail you have followed has led you to Hobart's Planet. If the evidence from the interrogation of a captured Chaos Space Marine of the Night Lords Legion is to be believed (though more often than not it can't be, the scum!), then Cypher plans to attack a team investigating a craft that crashed on the planet a year

ago. Why he is doing this is unknown, and in any case is of little importance compared to the need to capture him and return him to the Hock. If the Night Lords traitor is to be believed then Cypher only has a small force of Chaos Space Marines under his command.

The investigative team consists of half a dozen officials and an Imperial Guard squad that has been assigned as their escort. They are lightly armed, and will stand little chance if attacked by Cypher. The team have located the crashed space craft, but it is proving a slow and laborious process to track down all of the scattered wreckage. Currently the team is camped beside a major section of what appears to have been the cargo hold of the craft.

Hobart's Planet is a barren place, with no Human population and little indigenous life. The atmosphere is breathable, if rather low in oxygen. Its distance from Hobart's Star means that it is cold, especially during the long nights. Fortunately the crash site is currently on the day side of the planet, and the slow axial rotation of Hobart's Planet means that it will remain so for over 200 hours of standard earth time.

You approach the planet using silent running to ensure that Cypher, if he is here, will be unable to detect you. A passive sensor scan of the planet reveals the presence of the unsuspecting investigative team and then – may the Primarch be praised – the unmistakable signal of

heat shields flaring as a craft of similar size to your own enters the planet's atmosphere. If the traitor spoke true, then you have arrived at almost exactly the same time as Cypher. Your actions over the next few hours could effect the future of the Dark Angels forever...

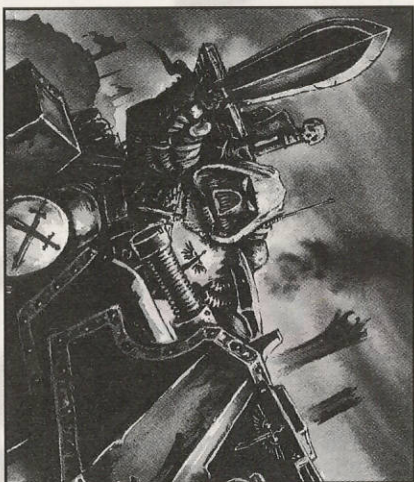
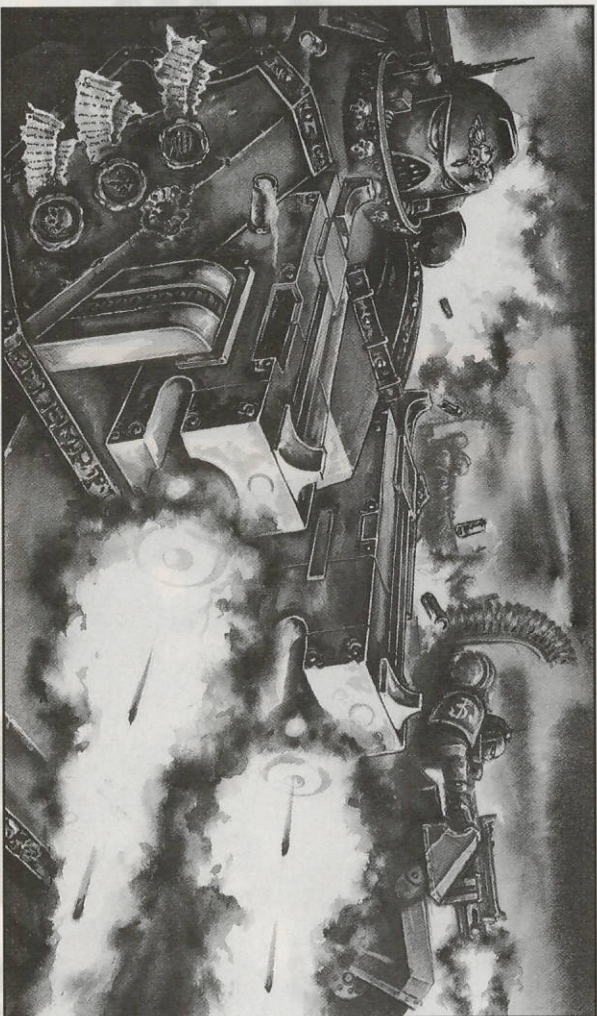

PICK ONE OF THE FOLLOWING OPTIONS...

- A:** Discretion is the better part of valour. You decide to send for aid from the rest of the Chapter. The reinforcements, which will arrive in a few days time, will ensure Cypher's defeat.
- B:** Protect the innocent. You decide to land quickly and place your force to help protect the investigators' camp. Cypher will have to go through you to get at the investigators!
- C:** Attack is the best form of defence. You will hold the bulk of your force in reserve and launch a counter-attack once Cypher has committed himself.
- D:** Guile and cunning will be my ally. You will allow Cypher to attack the camp. Then, as he returns to his transport ship you will spring a deadly ambush, just when he least expects it.

**ONCE BOTH YOU AND YOUR
OPPONENT HAVE MADE YOUR
CHOICES TURN TO PAGE 46**

A SECRET WAR CHAOS SPACE MARINE BRIEFING



So it was, that, since the death of their lord, you found yourself leading these followers of the Chaos gods. Ordinarily you would have refused the 'honour' of such a command, but in this case the rewards of successfully carrying out the mission laid upon these agents of Chaos could advance your own cause greatly. They have been ordered, by none other than Abaddon himself, to search for a device known as the Hand of Darkness. This device was lost when the Night Lords craft carrying it disappeared some three years ago, and finding it and returning it to Abaddon would put this most powerful of all Chaos Space Marines in your debt. And a debt such as that is worth the minor irritation of commanding this rabble.

Following the trail of the Night Lords warband after their attack on Purgatory was difficult, but, aided by the dark spirit that comes to you in your dreams and guides you towards the fate you can still only guess at, you have been successful. The Night Lords had journeyed to Hobart's Star, where, for reasons unknown, their craft had been destroyed and crashed onto Hobart's Planet. You follow their trail, entering the system on silent running to escape Imperial detection, and make your way to orbit the planet.

Your sensors reveal Hobart's Planet to be a barren place, with no Human population and little indigenous life. The atmosphere is breathable, if rather low in oxygen. Its distance from Hobart's Star means that it is cold, especially during the long nights. Fortunately the crash site is currently on the day side of the planet, and the slow axial rotation of Hobart's Planet means that it will remain so for over 200 hours of standard earth time.

Unfortunately your sensors also reveal that a small team of Imperial investigators seems to have been despatched to study the crashed craft. Your sensors cannot reveal the numbers or composition of the investigating force, but judging by the size of their landed transport craft it must be small. Nonetheless, this area is currently under the surety of none other than your old Chapter, the Dark Angels, and some of your ancient adversaries could well be providing an escort for the investigators.

But this is by the by, for you also know that time is of the essence. Currently the investigating team is camped beside a major section of what appears to have been the cargo hold of the craft. What you know, and they don't, is that this hold contains the Hand of Darkness. If you are to retrieve the artefact you must act quickly, before they find the device themselves. You issue orders to your helmsman to land on Hobart's Planet, and prepare a plan of attack...

A SECRET WAR

CHAOS SPACE MARINE BRIEFING

You are Cypher, and you have ended up in command of this misbegotten army of followers of the Chaos gods very much against your usual inclinations. However, ever since your millennia-long journey began in those distant days following the destruction of the Dark Angels' home world of Caliban, you have been forced to make allies where you can, in order that your own sacred duty may be advanced. That in so doing you have aided brigands, murderers and worse is unfortunate but necessary. Sometimes the ends must justify the means.

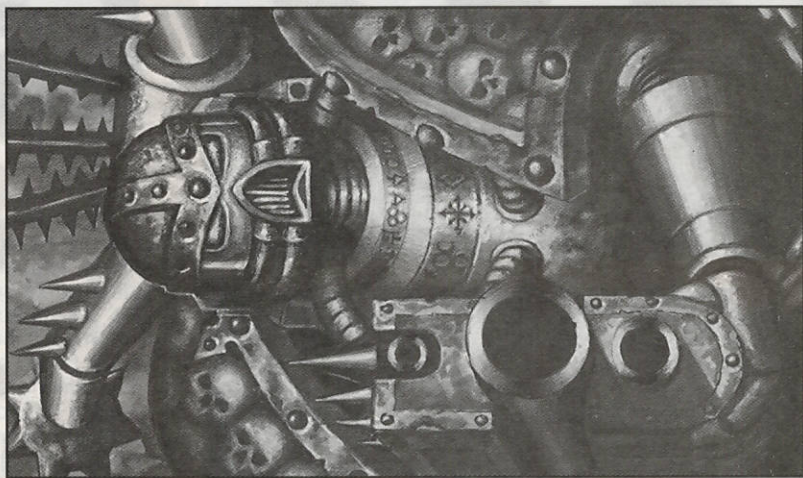

PICK ONE OF THE FOLLOWING OPTIONS...

- 1:** Tardiness invites disaster. Gathering your forces, you launch an immediate attack on the investigators. They must not be given time to find the Hand of Darkness.
- 2:** Knowledge breeds success. You despatch a squad to scout out the investigators camp. The information they bring back will allow you to launch a devastating attack.
- 3:** Caution protects the wary. You scout the enemy camp and station a rearguard to protect your line of retreat. Your attack and subsequent escape will be planned to the last detail.
- 4:** Many are the minions of Chaos. You will leave a squad to spy on the investigators while you go to gather additional forces. When you return in a few days, the reinforcements will ensure your victory.

**ONCE BOTH YOU AND YOUR
OPPONENT HAVE MADE YOUR
CHOICES, TURN TO PAGE 46**

WARNING!

**DO NOT READ THIS PAGE
WITHOUT FIRST REFERRING TO
THE INTRODUCTION OF THIS
SCENARIO ON PAGE 42.**

A SECRET WAR

THE CONFRONTATION

IMPORTANT: If you want to play the Secret War scenario, don't read this page before picking an option from the previous briefing pages.

The options that you and your opponent have chosen will determine which mission you play, and what special rules (if any) apply. To discover which mission and rules you'll be using, simply combine together the two choices you and your opponent have made. HINT: Try not to read any of the other paragraphs if you can avoid it; that way, when you play again the result will still be a surprise!

For example, if the Dark Angels player picked choice 'A' while the Chaos Space Marine player picked choice '1', then you'd look up paragraph 'A1' below.

A1

Realising his error, the Dark Angels commander turns his ship around and rushes back to Hobart's Planet, only to find that the investigators are already under attack.

Mission Played: Take and Hold (Chaos attacker)

Additional Special Rules: All Dark Angels units start in reserve. The only Imperial units in play at the start of the battle are the investigators and their Imperial Guard escort. Infiltration special rules may not be used.

A2

Realising his error, the Dark Angels commander turns his ship around and rushes back to Hobart's Planet, only to find that the forces of Chaos have infiltrated the investigators' camp and have launched an attack.

Mission Played: Take and Hold (Chaos attacker)

Additional Special Rules: All Dark Angels units start in reserve. The only Imperial units in play at the start of the battle are the investigators and their Imperial Guard escort.

A3

Realising his error, the Dark Angels commander turns his ship around and rushes back to Hobart's Planet, only to find that the investigators are already under attack from the bulk of the Chaos army.

Mission Played: Take and Hold (Chaos attacker)

Additional Special Rules: All Dark Angels units start in reserve. The only Imperial units in play at the start of the battle are the investigators and their Imperial Guard escort. The Chaos player must pick one unit in his army to be his rearguard. This unit may not be used in the battle.

A4

Both commanders slink off and collect additional troops to aid their attack. He that has most success recruiting extra followers will probably win the day.

Mission Played: None!

Additional Special Rules: Each player may add 2D6x10 points worth of troops to their army (each rolls separately). Then both players must pick a new option from their briefing page. They may not choose to collect further forces!

B1

The Dark Angels and Chaos Space Marines are attempting to move into position when they bump into each other. A fierce battle erupts!

Mission Played: Recon

Additional Special Rules: Neither side may infiltrate. The investigators and their escort are not used.

B2

The Dark Angels have just taken up their position blocking the route to the investigators' camp when Cypher launches a lightning attack with his whole army, in an attempt to clear them out of the way.

Mission Played: Blitz (Chaos attacker)

Additional Special Rules: The investigators and their escort are not used. The defender is not allowed to use fortifications or obstacles, and the attacker does not get a preliminary bombardment.

B3

The Dark Angels have established their position blocking the route to the investigators' camp when Cypher launches a deliberate attack with the bulk of his army, in an attempt to clear them out of the way.

Mission Played: Blitz (Chaos attacker)

Additional Special Rules: The investigators and their escort are not used. The defender is not allowed to use fortifications or obstacles, and the attacker does not get a preliminary bombardment. The Chaos player must pick one unit in his army to be his rearguard. This unit may not be used in the battle.

B4

Realising his error Cypher rushes back to the planet, but by the time he is ready to attack, the Dark Angels have dug in and built a solid defensive position.

Mission Played: Blitz (Chaos attacker)

Additional Special Rules: The investigators and their escort are not used. The defender is allowed to use fortifications or obstacles, but the attacker does not get a preliminary bombardment. All Chaos Heavy Support units start in reserve.

REINFORCEMENTS

If either player decided to go for reinforcements, then they should hang their heads in shame! Come on, you don't really expect your opponent to hang around for several days while you get some help, do you? Tsk, tsk! Anyway, as you head off for aid, you suddenly realise that your enemy will be long gone by the time you return. You rush back to the planet, but will be at a severe disadvantage in the coming battle unless your opponent made an equally foolish choice. What's more, in addition to any rules detailed above, any player that went for reinforcements while his opponent did not, loses all Moral High Ground rolls he is called upon to make...

C1

The Chaos army rushes headlong into the Dark Angels' trap. As the Chaos force attacks the camp, the Dark Angels reserves encircle them, so they can counter-attack from any direction.

Mission Played: Take and Hold (Chaos attacker)

Additional Special Rules: Infiltration special rules may not be used. Imperial reserves can enter from any table edge. Different units may enter play from different table edges if desired.

C2

Cypher's scouts inform him of the presence of the Dark Angels, but none the less he decides he must attack the camp and attempt to capture the Hand of Darkness.

Mission Played: Take and Hold (Chaos attacker)

Additional Special Rules: None!

C3

Cypher's scouts inform him of the presence of the Dark Angels, but none the less he decides he must attack the camp and attempt to capture the Hand of Darkness, keeping only one unit in reserve to act as a rearguard.

Mission Played: Take and Hold (Chaos attacker)

Additional Special Rules: The Chaos player must pick one unit in his army to be his rearguard. This unit may not be used in the battle.

C4

Realising his error, Cypher rushes back to Hobart's Planet and launches a rapid assault on the investigators' camp. Unfortunately this means that his slower moving troops will arrive late. Meanwhile, as the Chaos force attacks the camp, the Dark Angels reserves encircle the attackers so they can counter-attack from any direction.

Mission Played: Take and Hold (Chaos attacker)

Additional Special Rules: Infiltration special rules may not be used. Chaos Heavy Support and Troops start in reserve. Imperial reserves can enter from any table edge. Different Imperial units may enter play from different table edges if desired.

TAKE & HOLD MISSION OBJECTIVE

If you're called upon to play a Take and Hold mission, then the piece of terrain that is the mission objective should represent the wrecked portion of the hold that contains the Hand of Darkness.

THE INVESTIGATORS

More often than not, the Imperial player's forces will include the investigators studying the crashed space craft. The investigators consist of two units: an Imperial Guard squad with up to 20 points worth of upgrades (including a Veteran Sergeant if you want to take one), and a unit of 2D3 crash investigators. The crash investigators can be represented by Guardsmen armed with lasguns or laspistols; they have the same characteristics as Guardsmen, except that their WS, BS & Ld are all reduced by 1 point. Both units count as Troops for the purposes of set-up instructions.

D1

Cypher launches a lightning assault on the investigators' camp, capturing the Hand of Darkness. His rapid return forces the Dark Angels to spring their ambush before they are fully prepared.

Mission Played: Ambush (Imperial attacker)

Additional Special Rules: The investigators and their escort are not used. The Chaos player picks one model to be carrying the Hand of Darkness (he may keep this secret). If the model escapes, the Chaos player earns an additional D6 x 50 victory points. If he fails to escape then the Imperial player gains D6 x 50 VPs.

D2

Cypher's carefully executed attack on the investigators' camp captures the Hand of Darkness, but leaves the Dark Angels with plenty of time to set up a deadly ambush for his force as it returns to its space craft.

Mission Played: Ambush (Imperial attacker)

Additional Special Rules: The investigators and their escort are not used. The Imperial player does not have to roll a D6 to see which units may deploy at the start of the battle; he may choose to deploy any or all of his force. The Chaos player picks one model to be carrying the Hand of Darkness (he may keep this secret). If the model escapes, the Chaos player earns an additional D6 x 50 victory points. If he fails to escape then the Imperial player gains D6 x 50 VPs.

D3

Cypher's carefully executed attack on the investigators' camp captures the Hand of Darkness. Then, as he starts to return he hears that the rearguard he has left behind to cover his retreat has foiled the Dark Angels' attempt to set an ambush.

Mission Played: Patrol

Additional Special Rules: The investigators and their escort are not used. The Chaos player picks one model to be carrying the Hand of Darkness (he may keep this secret). If the model survives, the Chaos player earns an additional D6 x 50 victory points. If he dies then the Imperial player gains D6 x 50 VPs.

D4

Realising his error, Cypher rushes back to Hobart's Planet and hurls his forces forward to attack the investigators' camp. Unfortunately, as he moves up to make the attack he walks straight into the Dark Angels' carefully prepared ambush!

Mission Played: Ambush (Imperial attacker)

Additional Special Rules: The investigators and their escort are not used. The Imperial player does not have to roll a D6 to see which units may deploy at the start of the battle; instead he may choose to deploy any or all of his force. The Imperial player is assumed to have found the Hand of Darkness and whisked it away, and therefore gains D6 x 50 VPs.

STOP!

If you plan to play this mission, then we recommend you do so before you read the battle report in this issue. The battle report details what happened when Mark Bedford and Graham Davey fought out the Secret War scenario in the Studio. Read it after you've played the mission yourself and see how well you did compared to them!

ELFINCOURT

By Tuomas Pirinen

Would you like to create your own scenarios, but lack inspiration? Well, look no further than military history! For example, in this scenario Tuomas has taken the Battle of Agincourt and applied it to Warhammer. There are a whole host of great battles for you to base your games on: Custer's Last Stand, the Charge of the Light Brigade, the Battle of Culloden, etc. Check out your local library and have a go!

Deep in the lands of Bretonnia lies the Loren forest, the last of the great Wood Elf kingdoms of the Old World. Here, beneath the leaves of the mighty, old trees, creatures of legend still walk: mighty Treemen and graceful Unicorns, as well as strange woodland spirits known as Dryads, all live here in harmony with the Wood Elves. Usually the Wood Elves and the Bretonnians live in peace and respect each others borders, but more than once the Men and Elves have come to blows.

One of these clashes happened during the reign of King Charles VII. It was Machevort,

duc de Carcassonne who opened the hostilities. Duke Machevort was an ambitious and aggressive ruler, more concerned with the size of his domain than serving the Lady of the Lake or his King. His knights were little better; he attracted all the most dishonourable, unpleasant and least virtuous knights and barons to his standard. With the aid of these ruthless warriors, Machevort had conquered all the area between the River Brienne and the Vaults, but he desired more. Nor daring to challenge his powerful neighbour, the Duke of Quennesles, Machevort turned his eyes to the east, to the realm of the Wood Elves. Machevort knew full well the fate of those who travelled into the forest itself. But the forest of Loren was surrounded by the Wild Heath, a vast area of scrub and plains. For years Machevort coveted the Wild Heath, which the Elves claimed as part of their domain, and finally, after building his army to an unparalleled strength, he felt ready to take on the Wood Elves.

He sent his settlers to the Wild Heath to chop down the trees on the edge of Loren, ignoring the agreement between the Elves and the Kings of Bretonnia. His ruthless knights overturned the ancient standing stones and kept the Wood Elf Glade Riders at bay. Following the strict orders of the Duke, they never pursued the Elves into the forest itself. The Elven cavalry was powerless to stop their foes from violating the borders of Loren.

Worse still, Machevort had attacked at winter, and Orion and Ariel, the semi-divine rulers of Loren, slumbered deeply. The border guards sent word to Herion, fifth ruler of the Kindred of Beeches, whose duty it was to watch over the southern lands of Loren.

Upon hearing the news, Herion mustered his kindred and marched with hundreds of bowmen to drive away the invaders. The Wood Elves knew that they would have to fight a battle in the open field if they were to be rid of their enemy. Herion chose the plains of Elfincourt and sent his Scouts and Waywatchers to lure the enemy to battle, while he prepared to receive the Bretonnians.

The Wood Elves had lost many Glade Riders in the earlier clashes with the knights, and as it was the middle of the winter, the woodland spirits lay dormant. The Wood Elves would have to trust their longbows to see off the foe.

When Duke Machevort heard the news of the Elves mustering to meet him, he was overjoyed: if he could crush the lords of Loren, his new holdings would be secure. He called to arms all his knights, emptied his treasury to hire Tilean mercenaries armed with crossbows, and marched to meet the Elves. As they marched to Elfincourt, they saw the Elves taking positions at the edge of the forest. Duke Machevort had a numerically superior force, but the battlefield was a muddy plain and the knights under his command were arrogant, impetuous and notoriously hard to control. On the other hand, his opponent commanded a force of the finest archers in the known world. The scene was set for a bitter battle.

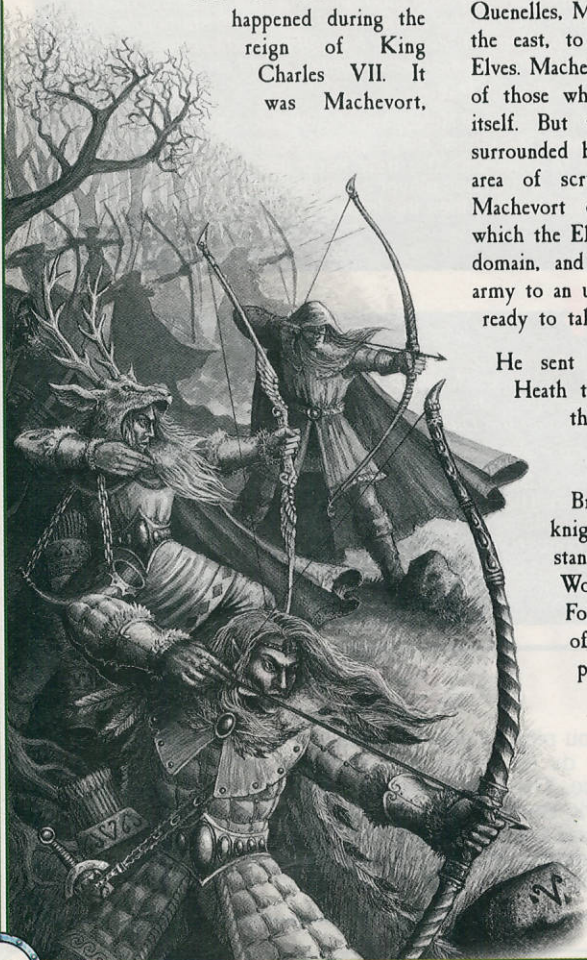

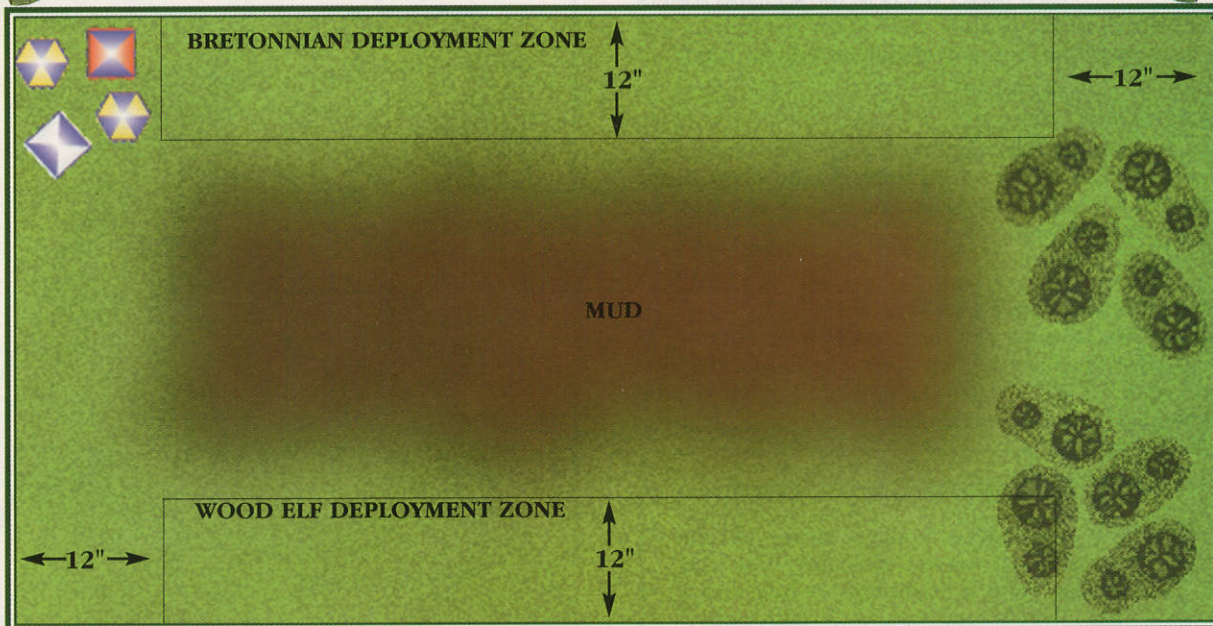

One of the most famous ballads of Bretonnia is the Chanson of Elfincourt, the tale of the battle between Lord Herion of Loren and the knights of Duke Machevort. The scenario detailed below allows you to recreate this battle.

FIGHTING THE BATTLE OF ELFINCOURT

This scenario is a battle between the army of Duke Machevort and an army of Wood Elf archers led by Herion of Athel Loren. It is therefore a scenario for two players, one playing the Bretonnians, the other Wood Elves.

OBJECTIVES

The Bretonnian objective is to cross the battlefield as quickly as possible and scatter the Wood Elves, strike through their lines and raze their camp. The Wood Elves must try to cause as many casualties as possible.

THE BATTLEFIELD

The setting for this battle is on the edge of the Loren forest, on the fields of Elfincourt. The Elves have chosen this field because it is hard terrain for mounted knights and they have a clear view to aim at the Bretonnians. See the battlefield map for details of how to set up your gaming table.

BATTLEFIELD MUD TABLE

- 1-2 The sticky mud makes progress very slow. The unit is reduced to half speed.
- 3-5 Roll D6 and reduce this many inches from the total movement of the troops.
- 6 With a mighty show of strength, the unit ploughs through the mud at full speed, with no reductions.

SPECIAL RULES

Mud. The area indicated in the map is covered in sticky mud, caused by rain the day before. Roll a D6 for each cavalry unit which, in any part of its movement phase, tries to move through the muddy area, and refer to the Battlefield Mud table.

THE FORCES

This scenario has been designed to be a classic clash between two very different forces: one of mounted knights and one consisting almost entirely of archers.

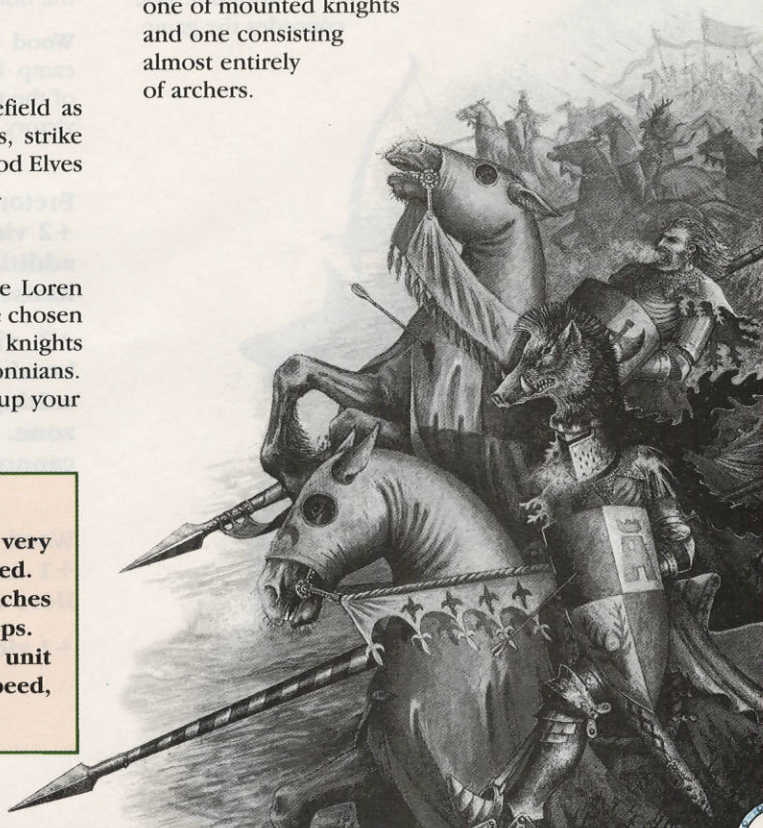

Each player refers to the scenario rosters in order to choose his models for the game. The roster tells which units and characters may be used.

DEPLOYMENT

The Bretonnians are deployed first. The Bretonnian player deploys in the area shown on the deployment map. The Wood Elves are deployed second, as shown on the deployment map.

WHO HAS THE FIRST TURN?

Bretonnians have the first turn, so they may not pray. At the beginning of each of their turns they must roll D6 for each unit of Bretonnian knights and refer to the Bretonnian Obedience table below:

BRETONNIAN OBEDIENCE TABLE

- 1-2 The impetuous knights move directly towards the nearest mercenary unit and charge them if possible, shouting things like "Out of my way, dirty mercenary!" and, if they reach, fight in hand-to-hand combat until one side breaks.
- 3-4 The knights, in their eagerness, will move at full speed towards closest enemy unit, unless they first pass a Ld test.
- 5-6 The knights follow your orders as normal and you may move them as you wish.

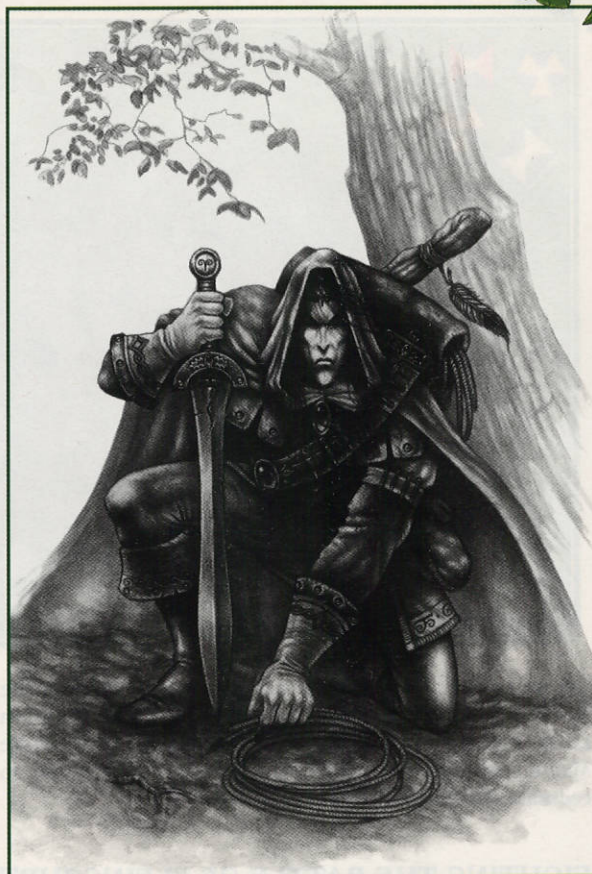

HOW LONG IS THE BATTLE?

The battle lasts for five turns, or until one side concedes the game.

VICTORY CONDITIONS

When the battle is over, calculate the victory points in the normal manner, with the following bonuses:

Wood Elf Camp. Behind the Wood Elf lines is their camp. If any Bretonnian unit exits off the southern edge of the table they can raze the camp and gain additional victory points as detailed below.

Bretonnians:

+2 victory points if Herion is slain. This is in addition to any victory points Herion is worth himself.

+2 victory points if any Bretonnian unit breaks through to the Wood Elf camp, by exiting the field via the Wood Elf deployment zone. Note that units which exit the field cannot return.

Wood Elves:

+1 extra victory point for each Bretonnian Hero slain in battle.

+1 victory Point if the Wood Elf camp is safe.

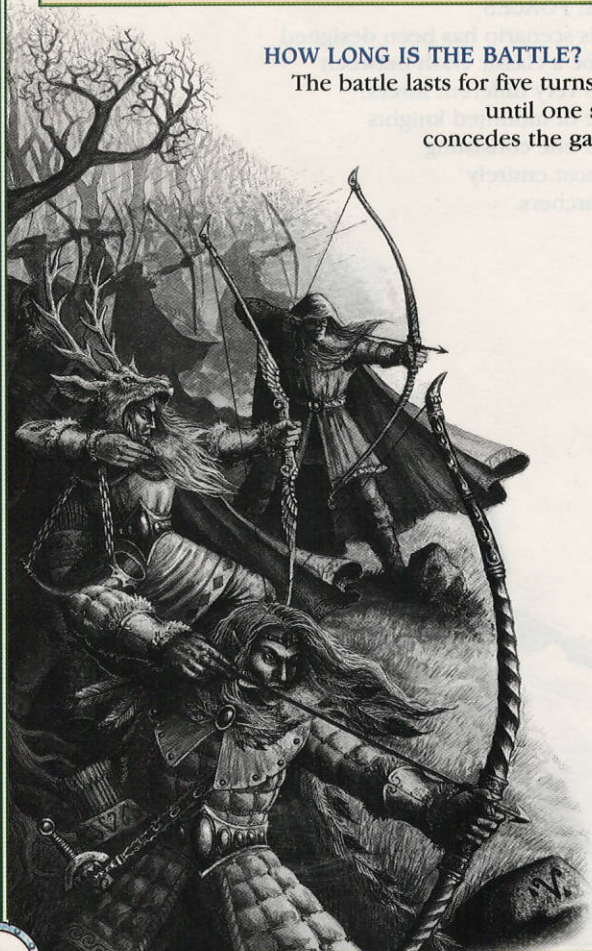



LORD HERION'S WOOD ELF ARCHERS

The Wood Elf army consists of 2,000 points worth of troops chosen from the list below. Whenever the scenario calls for an exception to the Warhammer armies list, this will be indicated below. Every unit is permitted to have a Champion (without magic

items), standard and a musician as normal. Units may not have magic standards unless otherwise noted.

Herion. Herion is a Wood Elf General as detailed in the Warhammer Armies Wood Elves book. He may ride an Elven Steed and may be equipped with any armour and weapons normally available to Wood Elf characters. He may have up to 75 points worth of magic items.

0-2 Heroes of the Kindred. Your army may include up to two Wood Elf Heroes. They may ride Elven Steeds and may be equipped with any armour and weapons normally available to Wood Elf characters. They may have up to 50 points worth of magic items each.

Wood Elf Mage. Your army may include a single Wood Elf Mage (level 1-3) on foot, who may have up to 25 points worth of magic items.

1+ unit of Elf Archers

Any number of units of Wood Elf Scouts

0-1 unit of Wood Elf Waywatchers

0-1 unit of Wardancers

0-1 unit of Glade Guards

0-1 unit of Glade Riders

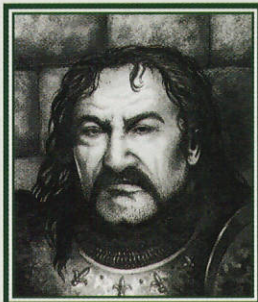

DUKE MACHEVORT'S KNIGHTS

The Bretonnian army consists of 2,500 points worth of troops chosen from the list below. Whenever the scenario calls for an exception to the Warhammer armies list, this will be indicated below. Every unit is permitted to have a

Champion (without magic items), standard and a musician as normal. Units may not have magic standards unless otherwise noted.

Machevort. Machevort is a Bretonnian General as detailed in the Warhammer Armies Bretonnia book. He may ride a barded Bretonnian Warhorse and may be equipped with any armour and weapons normally available

to Bretonnian knightly characters. He has the Knight's Virtue and up to one other knightly virtue. He may have up to 75 points worth of magic items.



0-3 Bretonnian Knightly Heroes. Your army may include up to three Bretonnian Heroes. They may ride Bretonnian Warhorses and may be equipped with any armour and weapons normally available to Bretonnian knightly characters. They may have up to 50 points worth of magic items each. They all have the Knight's Virtue.

0-1 unit of Questing Knights

1+ units of Knights of the Realm.

Any number of units of Knights Errant

Any number of units of Mounted Squires

0-2 units of Men-at-Arms

0-1 unit of Dogs of War armed with crossbows.

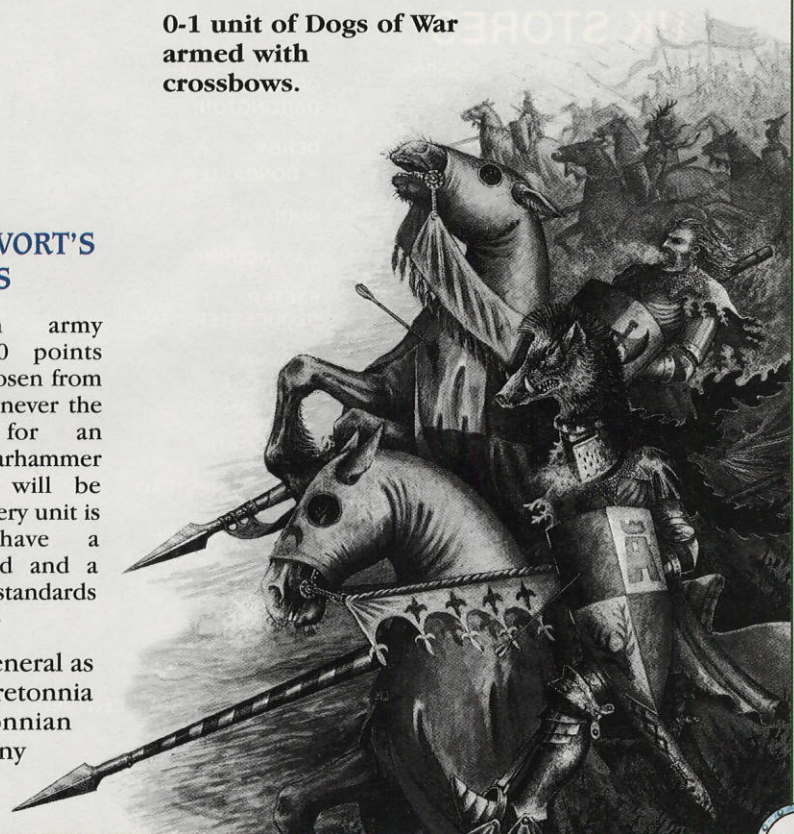



ALL THE GAMES WORKSHOP ACTION IN EVERY STORE!

If you've always really wanted to lead an army of heroic knights across the battlefield or command a strike force of Space Marines against the enemies of Mankind, then get down to your nearest Games Workshop store.

+++downloading +++

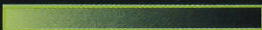

decryption key valid.....

+++ decrypting +++



+++ COMPLETE +++

Games Workshop Opening Times Mon-Tues & Fri-Sat:

10am to 6pm. Weds-Thurs: Midday to 8pm. Sun: 10am to 4pm.

Stores marked with a white star are not open on Sundays. Stores in shopping centres may not adhere to these opening times so ring the store for details.

Want to know where your nearest store is and what's going on there? Just drop in or give them a call. Shops marked with a white circle also have a Games Workshop Gaming Club. Contact your local store for details!

UK STORES

Use this list of Games Workshop stores to find the nearest one to you.

ALTRINCHAM: Unit 1, 17 Grafton Street.

Tel: 0161 9299896

BASINGSTOKE: 3 Potters Walk, Wote Street.

Tel: 01256 466050

BATH: 30 Upper Borough Walls.

Tel: 01225 314414

BEDFORD: 10 Greyfriars. Tel: 01234 273663

BIRMINGHAM: 116 Corporation Street.

Tel: 0121 2367880

BLACKPOOL: 8 Birlay Street. Tel: 01253 752056

BLUEWATER CENTRE: Upper Thames Walk,

Bluewater, Greenhithe, Kent.

BOLTON: Unit 13, The Gate Centre.

Tel: 01204 362131

BOURNEMOUTH: 24 Post Office Road.

Tel: 01202 319292

BRADFORD: 5 Broadway. Tel: 01274 739353

BRIGHTON: 7 Nile Pavilions, Nile Street.

Tel: 01273 203333

● **BRISTOL (CENTRAL):** 13 Broad Weir.

Tel: 0117 9251533

● **BRISTOL (CRIBBS CAUSEWAY):** Unit 129

(next to M&S), upper level, The Mall at Cribbs

Causeway. Tel: 01179 592528

CAMBRIDGE: 8 Bridge Street. Tel: 01223 313350

CANTERBURY: 5 Iron Bar Lane. Tel: 01227

452880

CARLISLE: 2 Earls Lane, Lowther Street.

Tel: 01228 598216

CHELMSFORD: Unit 4c, Phase II, The Meadows

Shopping Centre, Chelmsford. Tel: 01245 490048

CHELTENHAM: 16 Pitville Street.

Tel: 01242 228419

CHESTER: 112 Foregate Street. Tel: 01244311967

COLCHESTER: 2 Short Wyre Street.

Tel: 01206 767279

★ **COVENTRY:** Unit 39, Upper Level, Cathedral Lanes Shopping Centre.

Tel: 01203 227311

CRAWLEY: 11 Broadway. Tel: 01293 552072

DARLINGTON: 78 Skinner Gate.

Tel: 01325 382463

DERBY: 42 Sadler Gate. Tel: 01332 371657

★ **DONCASTER:** Unit 10, The Colonnades.

Tel: 01302 320535

DUDLEY: Unit 36, Merry Hill Centre, Brierly Hill,

Dudley. Tel: 01384 481818

EASTBOURNE: 13 Terminus Road.

Tel: 01323 641423

EXETER: 37 Princess Hay. Tel: 01392 490305

GLOUCESTER: 35 Clarence Street.

Tel: 01452 505033

GRIMSBY: 9 West St Marys Gate.

Tel: 01472 347757

● **GUILDFORD:** 12 Tunsgate.

Tel: 01483 451793

HARROGATE: 29 Beulah Street.

Tel: 01423 564310

HEMEL HEMPSTEAD: 16 Bridge Street.

Tel: 01442 249752

★ **HIGH WYCOMBE:** Unit 29, The Balcony,

The Octagon Centre. Tel: 01494 531494

HULL: 30 Paragon Street. Tel: 01482 589576

★ **IPSWICH:** 2nd Floor, Debenhams, Waterloo

House. Tel: 01473 210031

LEAMINGTON: 22 Park Street. Tel: 01926 435771

LEEDS (CENTRAL): 12-16 Central Road.

Tel: 0113 2420834

LEEDS (WHITE ROSE CENTRE): Unit 28D

(near Debenhams), White Rose Centre, Leeds.

Tel: 0113 2723470

LEICESTER: 16/20 Silver Street.

Tel: 0116 2530510

● **LINCOLN:** Unit SUA, Saltergate (on outside of

Waterside Centre). Tel: 01522 548027

LIVERPOOL: 47 Lord Street. Tel: 0151 2581404

LOUGHBOROUGH: 22 Biggin Street.

Tel: 01509 238107

LUTON: 12 Park Street. Tel: 01582 417474

MAIDENHEAD: 2 Blandy House,

3/5 King Street. Tel: 01628 621854

MAIDSTONE: Unit 6, 1-9 Pudding Lane.

Tel: 01622 677435

● **MANCHESTER (CENTRAL):** 69/70 Marsden

Court (lower level near Argos), Arndale Centre.

Tel: 0161 8346871

● **MANCHESTER (TRAFFORD CENTRE):**

No. 77, Festival Village, The Trafford Centre,

Trafford Park. Tel: 0161 7472121

MIDDLESBROUGH: 39 Dundas Street.

Tel: 01642 254091

MILTON KEYNES: Unit 2, West End Extension,

504 Silbury Boulevard, Milton Keynes Shopping

Centre (on outside of centre near M&S).

Tel: 01908 690477

NEWCASTLE (CENTRAL): 63 Clayton Street.

Tel: 01912 322418

NEWCASTLE (METROCENTRE): Unit B14, First

Floor (near the Mediterranean Village).

Tel: 0191 4610950

★ **NORTHAMPTON:** 6/7 The Friary, Upper Level

(near Sainsbury's), Grosvenor Centre.

Tel: 01604 636687

NORWICH: 12-14 Exchange Street.

Tel: 01603 767656

● **NOTTINGHAM (CENTRAL):** 34a Friar Lane.

Tel: 0115 9480651

● **NOTTINGHAM (HQ):** Games Workshop HQ,

Willow Road, Lenton, Nottingham (near Central TV

studios). Tel: 0115 9168410

● **OXFORD:** 1A New Inn, Hall Street.

Tel: 01865 242182

PETERBOROUGH:

3 Wentworth Street. Tel: 01733 890052

PLYMOUTH: 84 Cornwall Street. Tel: 01752 254121



All Games Workshop stores provide:

- *The complete range of Games Workshop games, miniatures and accessories.*
- *The chance to learn to play Games Workshop games – our enthusiastic staff are ready to show you how.*
- *Exciting battles for you to take part in every week.*
- *Help with your miniature modelling and painting in the store.*
- *A Mail Order service for components and older miniatures.*
- *The latest releases every Saturday.*



POOLE: Unit 12 Towngate Centre, High Street. Tel: 01202 685634

● **PORTSMOUTH:** 34 Arundel Street. Tel: 01705 876266

PRESTON: 15 Miller Arcade. Tel: 01772 821855

READING: Unit 3, Cheapside. Tel: 0118 9598693

ST ALBANS: 18 Heritage Close, High Street. Tel: 01727 861193

SALISBURY: 1b Winchester Street. Tel: 01722 330955

SHEFFIELD (CENTRAL): 16 Fitzwilliam Gate. Tel: 0114 2750114

SHEFFIELD (MEADOWHALL CENTRE): 91B High Street, Upper Mall (next to entrance near Boots). Tel: 0114 2569836

SHREWSBURY: 2 Bridge Street. Tel: 01743 362007

SLOUGH: 101 High Street. Tel: 01753 575675

SOLIHULL: 690 Warwick Road. Tel: 0121 7057997

SOUTHAMPTON: 23 East Street. Tel: 01703 331962

SOUTHEND: 12 Southchurch Road. Tel: 01702 461251

SOUTHPORT: Unit K2, Marble Place Shopping Centre. Tel: 01704 501255

STOCKPORT: 32 Mersey Square. Tel: 0161 4741427

STOKE ON TRENT: 27 Stafford Street, Hanley. Tel: 01782 205287

SUNDERLAND: 253 York Street, (just off the high street near M&S). Tel: 0191 5673646

SWINDON: 17 Fleet Street. Tel: 01793 436036

THURROCK LAKESIDE: Unit 415, Level 3/Food Court, Thurrock Lakeside. Tel: 01708 867133

TORQUAY: 12 Market Street. Tel: 01803 201036

TRURO: Unit 1, Bridge house, New Bridge Street. Tel: 01872 320047

TUNBRIDGE WELLS: 4A Camden Road. Tel: 01892 525783

WALSALL: Old Square Shopping Centre. Tel: 01922 725207

WARRINGTON: Unit 20, Time Square (near Curry's). Tel: 01925 651984

WINCHESTER: 6 St Georges Street. Tel: 01962 86 0199

WOKING: Unit 3 Cleary Court. Tel: 01483 771675

WOLVERHAMPTON: Unit 98, Mander Centre. Tel: 01902 310466

WORCESTER: 4 Charles Street. Tel: 01905616707

YORK: 13a Lendal. Tel: 01904 628014

LONDON (INNER M25)

BROMLEY: Unit 8, The Mall, Bromley, Kent. Tel: 0181 4660678

BRENT CROSS: Unit F9, Lower mall (near Fenwicks), Brent Cross Shopping Centre. Tel: 0181 2024979

CROYDON: Unit 35, Drummond Centre (outside at the back of the centre), Keeley Road. Tel: 0181 6804600

EALING: 52D St Saviours Mall (towards back of the centre), Ealing Broadway Centre. Tel: 0181 8400171

ENFIELD: 3/5 Genotin Road. Tel: 0181 3633238

● **HAMMERSMITH:** 161 King Street. Tel: 0181 8469744

HARROW: 296 Station Road. Tel: 0181 861 2350

KENSINGTON: Shop 7, Lancer Square, Kensington Church Street. Tel: 0171 9377011

● **KINGSTON ON THAMES:** 33 Fife Road. Tel: 0181 5495224

● **LONDON (CENTRAL):** Unit F10, The Plaza Shopping Centre, 1st floor, 116-128 Oxford Street. Tel: 01714 360839

RICHMOND: Unit 8, Westminster House, Kew Road. Tel: 0181 9486122

★ **ROMFORD:** 12 Quadrant Arcade. Tel: 0708 742140

STAINES: 52D Elmsleigh Centre (at back of M&S). Tel: 01784 460675

SUTTON: Unit 26, Upper Mall, Times Square Shopping Centre. Tel: 0181 7709454

WATFORD: Unit Q1A, Harlequin Centre, Queens Road. Tel: 01923 245388

SCOTLAND

ABERDEEN: Unit 1, 30/40 Kirkgate. Tel: 01224 621261

AYR: 10 Arran Mall, Dalblair Arcade (behind Hourstons dept. store). Tel: 01292 610673

DUNDEE: 110 Commercial Street. Tel: 01382 202382

EAST KILBRIDE: 4 Righead Gate (at the back of M&S). Tel: 01355 224680

EDINBURGH: 136 High Street. Tel: 0131 2206540

● **GLASGOW:** 66 Queen Street. Tel: 0141 2263762

PERTH: 6 Fleshers Vennels. Tel: 01738 445840

STIRLING: 14 Barnton Street. Tel: 01786 448263

WALES

● **CARDIFF:** 31 High Street. Tel: 01222 644917

NEWPORT: 25 Skinner Street. Tel: 01633 256295

SWANSEA: 45 Princess Way. Tel: 01792 463969

NORTHERN IRELAND

BELFAST: 70A Castle Court (towards back of the centre). Tel: 01232 233684

IRELAND

BLANCHARDSTOWN: Unit 249, The Blanchardstown Centre (near the yellow entrance), Co. Dublin. Tel: 01 822 3868

DUBLIN: Unit 3, Lower Liffey Street, Dublin 1 Ireland. Tel: 01 8725791

DENMARK

★ **COPENHAGEN:** FREDERIKSBORGGADE 5, Tel: ++ 33 12 22 17

NETHERLANDS

AMSTERDAM: ROKIN 36, 1012KT

AMSTERDAM: Tel: ++ 020 6223 863

ROTTERDAM: VAN OLDENBARNEVELT PLAATS 452 Tel: ++ 102 800 268



GAMES WORKSHOP
STORES

GRAND OPENINGS

We are holding Grand Openings
and Grand Re-Openings in the following
stores on 1st & 2nd May 1999:

DARLINGTON

78 Skinner Gate.
Tel. 01325 382463

PERTH

6 Flesher Vennels.
Tel. 01738 445840



CHECK OUT THE SPECIAL OFFERS AND MONEY-OFF VOUCHERS
FROM LAST MONTH'S WHITE DWARF. MAKE SURE YOU DASH
DOWN TO THE GRAND OPENING NEAR YOU!

BATTLEFLEET

GOTHIC™

INTO THE LIGHT

Battlefleet Gothic Participation Game



SATURDAY 24TH APRIL

As more Chaos warfleets pour into the Gothic Sector, the war reaches new heights of carnage.

This huge game will be played across the country, with the action in your battle affecting every other store on the day, through a special, linked campaign.

Come down with your ships, or use the store's vessels to take part.



Come down to your local Games Workshop store and game!

You don't need any of your own figures to take part in these events – we'll provide everything you need. In many events you can bring your own troops to take part with if you wish.

CALL YOUR LOCAL STORE FOR DETAILS

BEGINNERS

Our Sundays are specially designed to help those who have just started out in the Games Workshop hobby. Whether you want to lead the planetary assaults of the Space Marines or command the hordes of the Undead into battle, you can learn about playing, painting and collecting an army in our stores.

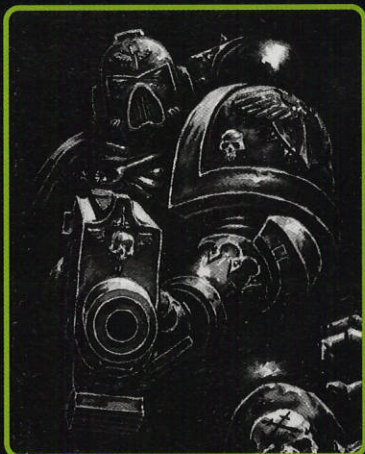

SATURDAYS

Saturday is big gaming day in our stores. Every week a different, awesomely huge game rages across the battlefield in each of our stores! Not only that, but every Saturday our latest releases arrive!

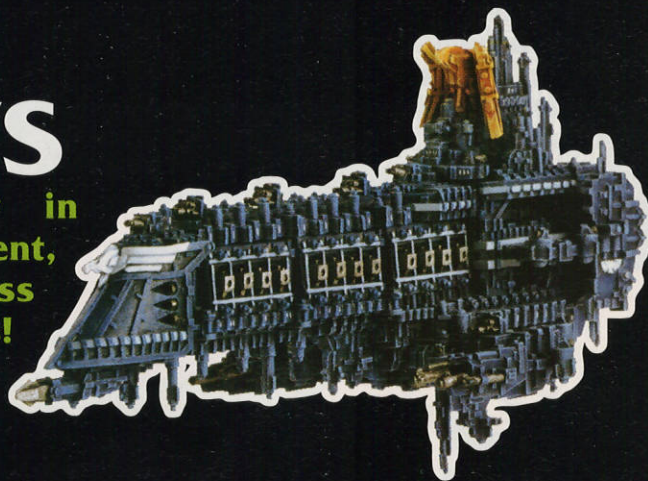

GAMES NIGHTS

WARHAMMER®
40,000

WARHAMMER

WEDNESDAY

THURSDAY

Once you're past the beginners stage, our Games Nights on Wednesday & Thursday are for you. Learn more about gaming, tactics, army building and advanced painting techniques at our Games Nights.

Some of our stores aren't open on Sundays, or late nights, but do have special beginners & gaming events – call your local store for details. Stores that are closed on Sundays are Coventry, Doncaster, High Wycombe, Ipswich, Northampton, Romford, Staines and Copenhagen.





GAMES WORKSHOP STORES



BRISTOL

ROY SANDERS



Roy Sanders,
GW Bristol Manger

HIVE HOST KANANN

• STORE ARMY OF THE MONTH • STORE ARMY OF THE MONTH •

I wanted a Tyranid army for one main reason; one of my friends, with whom I have been playing 40K for years, used to dread the sight of a Tyranid army. 'Tyranid Attack' were words that he really did not want mentioned while he was around and the mere sight of the 'pig-ugly aliens' used to give him nightmares. Seizing this opportunity to wind up my mate, I immediately decided that a Tyranid army was a must for the new edition of my favourite game.

On the week of release I wandered around to my friend's house to show everyone how cool and much better the new rules were. I went on to win the 'Last Man Standing' introductory scenario that we played that night, after I had coaxed everyone into actually playing against my new army. That was a games night I never forgot.

With the help of my friend Saul Painter, we painted Hive Host Kanann. The army was designed to be able to deal with (hopefully) nearly every enemy and mission objective that it could face in the war-torn future of the 41st Millennium. There is a little of everything in the army list, for two reasons:

- 1) Because the Tyranid army list in the rulebook is not too extensive, you can afford to include everything in a reasonably sized army and not lose out.
- 2) If you only choose the really powerful units, i.e. Genestealers or Carnifexes, you have an army which is great at close combat and nothing else.

The force is split into three segments of the hive mind: – Blast, Sacrifice and Assault.

In the Blast section we have four units: the Zoanthropes, Biovores, Tyranid Warriors and the Hive Tyrant. The Zoanthropes' job is to take out any heavily

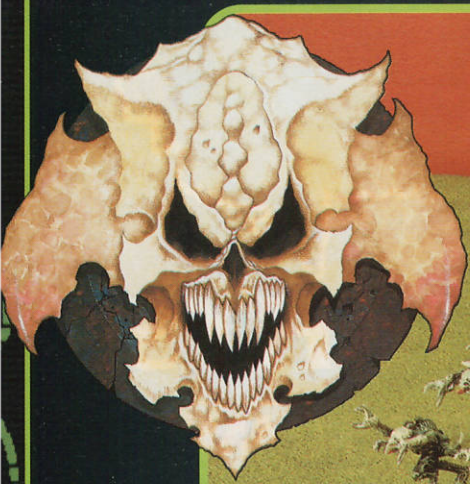

armoured troop type that looks as though it may pose a major threat before the assault troops reach them, such as Terminators. All the Zoanthropes fire at the same target until it is destroyed or reduced to the point where it is no longer a threat to the main Tyranid force.

The Biovores merely pound any lightly armoured troops until they are broken or harmless. They always fire at the same target and normally go for any central unit, so that the Spore Mines may do damage even if they scatter and miss! Usual targets are Eldar Guardians, Imperial Guard or Space Marine Scouts.

The Tyranid Warriors are split into two sections: troop killers and tank killers. The Hive Tyrant is a 'floating force' – if it gets into combat then hey, what the heck, the enemy will just have to die a close up and very painful death!

In the Sacrifice section we have Termagants, Hormagaunts, Carnifex and Lictor, to make up the second part of my army.

The Termagants' role is to screen the Genestealers until they are close enough to get into combat, and to shoot at anything that is stupid enough to get into the range of the fleshborers (18 shots from each unit!).

The Hormagaunts, Carnifex and Lictor move forward in an effort to get themselves shot at by every enemy heavy weapon, and to engage any unit that they can



**TYRANID
CARNIFEX**

reach in melee combat until the Genestealers get there. If the enemy is concentrating their fire at these units, then they aren't shooting at my Synapse creatures, Heavy Support or my assault units.

Last comes the Assault section. The two Genestealer units are the only troops that I feel must get into combat every battle, for one very simple reason; whatever they touch dies very quickly. They are shielded by the Sacrifice units, while the Blast units deal with any ranged threat to their survival.

The army as a whole works well together, with every unit being given strict orders by the Hive Tyrant. In my mind it also proves that a Tyranid army is not just a close combat monstrosity, but has the ability to wipe out the foe with the awesome weaponry at the Tyranid commander's disposal. But I'm not going to argue one bit if they actually manage to make it into hand-to-hand as well, oh no, quite the opposite...

**Look out for
more armies
from our
stores over
the next few
months.**





GAMES WORKSHOP'S 200th STORE!

Our Amsterdam store has just opened, not only joining Rotterdam to make it our second store in Holland, but also making it Games Workshop's 200th store in the world! Games Workshop now has stores in 16 countries around the world, selling Warhammer in English, French, German, Spanish, Italian, Japanese and Chinese!

AMSTERDAM STORE

The address for our NEW Amsterdam store is:

**Rokin 36,
1012KT Amsterdam
NOW OPEN**

Ring for more details
on tel: ++ 020 6223 863



LONDON CENTRAL STORE

The address of the London Central store is:

**Unit F10,
The Plaza
Shopping Centre,
1st floor,
116-128 Oxford
Street, London**

Tel: 01714 360839

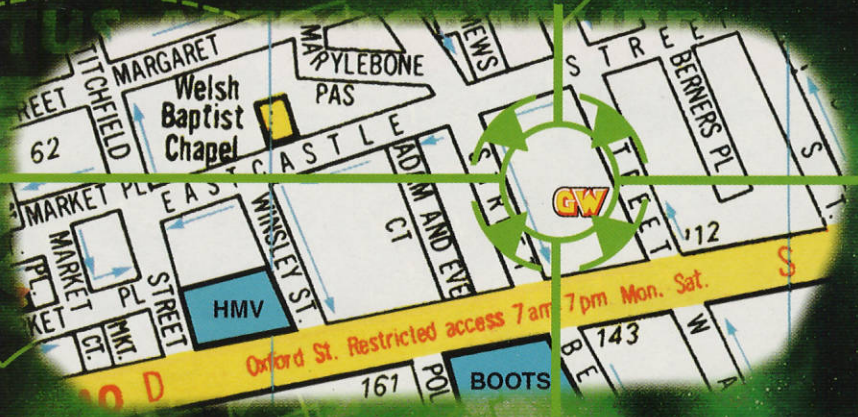

GAMES WORKSHOP IS OPENING A NEW STORE AT THE NEW BRAEHEAD SHOPPING CENTRE IN GLASGOW. LOOK OUT FOR MORE DETAILS IN WHITE DWARF 234.





BATTLEFLEET

GOTHIC™

OUT OF THE DARKNESS

Battlefleet Gothic Participation Game

Saturday 1st May 1999

WAR ERUPTS AS CHAOS FLEETS ASSAULT THE BASTIONS OF THE GOTHIC SECTOR. SEE THE AWESOME BLACKSTONE FORTRESS IN ACTION AND JOIN IN THE CONFLICT.

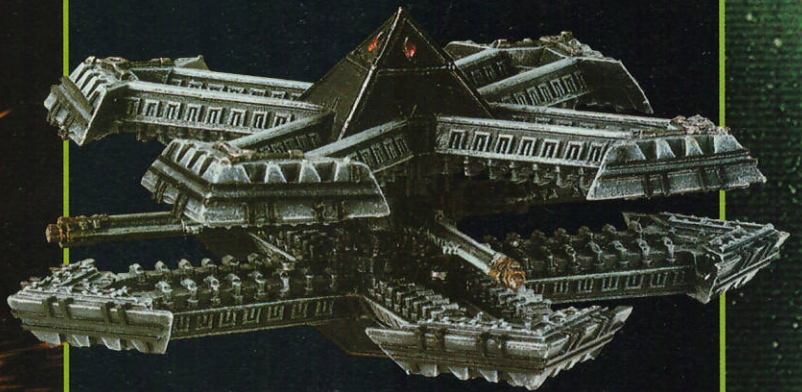

Abaddon has found a way to reactivate the ancient alien artifacts known as the Blackstone Fortresses. These mighty bastions, which are the key to the Imperial defence of the Gothic Sector, can be used by Chaos to destroy entire planets!

Come down to your local Games Workshop store on Saturday 1st May, (the day the Blackstone Fortress is released), and take part in the very first conflict involving these mighty behemoths of space.

Bring your own ships to take part, or use the store's miniatures to play in the biggest ever game of Battlefleet Gothic.

IN EVERY STORE!



BATTLEFLEET GOTHIC™

De'Aynes Fighting Ships of the Gothic Sector

A brief treatise on Eldar ships known to have taken part in the conflict. By Gav Thorpe.

Eldar Shadow class cruisers – *Black Star, Child of Khaine, Celestial King, Chariot of Mathurir, Fhiann Rethol, Bright Claw*

+++Message Transmitted: 1574999M41
+++Encryption Cypher: Gold
+++Classification Rating: Senioris
+++Ref: OG98E4/VT/BS
+++File With: Eldar/ Starcraft
+++Crossfile: Piracy/
Xenocide/ Alien
Technology



Suffer not the alien.

The *Bright Claw* was hunted on and off for seven years by Fleet Admiral Lancer, after it led an attack on a convoy destined for Port Maw, destroying the ship carrying the Fleet Admiral's three sons in the process. The Eldar once used this obsession to lure Lancer and his fleet into an ambush near the edges of the Graildark Nebula, but the plan backfired when Imperial frigates detected the Eldar ships in a freak ion storm. Lancer was able to prepare his fleet for the attack, catching the Eldar unawares. In this encounter the *Bright Claw* managed to escape, mainly due to Lancer's

insistence that his flagship, the *Achilles*, was the only vessel allowed to deliver the killing blow. Lancer eventually got his revenge at the end of the Gothic War. As the Eldar/Imperial alliance began to fragment, Lancer was on routine patrol through the Elysium system when he encountered the *Bright Claw*. The Eldar vessel failed to respond properly to his challenges and he opened fire at close range, smashing the alien ship to pieces. The *Achilles* continued to pour fire into the shattered hulk until the Fleet Admiral was sure there could be no survivors.

Gothic War Training Dogma

The commander of a Shadow will endeavour for the 'quick kill' against your ships. He will use what celestial features exist to protect him from long range attack while he positions himself. Then he will attack, using his vessel's high speed to get into extremely close range before unleashing a volley of fire more effective than a full broadside from a Retribution class battleship. On top of this, the enemy will launch a wave of torpedoes into your formation before slipping away, adding to the confusion and increasing the chances that you will be unable to form an effective reprimand for his gall. He will then seek the shelter of gas clouds or an asteroid field whilst reloading his weaponry and waiting for the opportunity to strike again.

Class:		Eldar Shadow Class Cruiser			Points:	210	Notes:
Type/Hits:	Armament	Rng/Spd	Firepower/Strength	Arc			
Cruiser/6	Keel Torpedoes	spd 30cm	4	Front	Armour: 4+		
Speed: 10/20/25	Prow Batteries	30	12	Front	Shields: Holofields		
Turns: Special					Turrets: 0		

Eldar Aconite class frigates – *Stings of Eternity, Siren Cry*

+++Message Transmitted: 1574999M41
+++Encryption Cypher: Gold
+++Classification Rating: Senioris
+++Ref: RT39B6
+++File With: Eldar/ Starcraft
+++Crossfile: Piracy/
Xenocide/ Alien
Technology



"You cannot defeat us, Human. We have eternity on our side."
- Lord-Falcon Marethe
of the Siren Cry.

The relatively short range of an Aconite's laser batteries is of little consequence when compared to its high speed and agility. Squadrons of Aconites are easily able to overpower escort ships of other races, as was much seen during the Gothic War. A popular strategy was for the Aconite squadrons to eliminate enemy destroyers and frigates first. This enabled the swift Eldar vessels to attack from behind the enemy capital ships, where they would be safe from retaliation. It was not until Lord Admiral Ravensburg ordered all battleships to be closely escorted by at least three frigates at all times that an effective defence was found against this tactic.

Class:		Eldar Aconite Class Frigate			Points:	65	Notes:
Type/Hits:	Armament	Rng/Spd	Firepower/Strength	Arc			
Escort/1	Prow Batteries	30	5	Front	Armour: 4+		
Speed: 10/20/30					Shields: Holofields		
Turns: Special					Turrets: 0		

Eldar Eclipse class cruisers – Silent Warrior, Asuryan's Chosen, Stardeath, Eliarenath's Gift

The Eldar starship *Eliarenath's Gift* earned its name from the strange circumstances surrounding its first encounter with Imperial vessels. It was several months after the Battle for Gethsemane when a patrol fleet, led by Captain Durhan of the *Deacis III*, encountered a lone Eldar ship moving stealthily through the dense asteroid fields of Melian Secundus. When confronted, the Eldar pirates, who called their ship *Eliarenath's Gift*, claimed they had located an Ork lair and were preparing to attack. Captain Durhan proposed a joint venture, which the Eldar readily accepted. The Eldar ship led the Imperial fleet deep into the asteroid field, where they did indeed find evidence of a large Orkish presence. Before the assault began, the Eldar fell out of formation, claiming that their mainsail had been damaged by a collision with a small asteroid. Captain Durhan duly continued the attack, only to discover that the Orks were waiting for him. The Ork attack was fast and brutal, and only the severely damaged *Deacis III* and a lone Sword class frigate evaded destruction. It was only later that Durhan was to learn, from the Eldar themselves, that *Eliarenath* is a figure from Eldar legend; she reputedly betrayed the folk hero Eldanash to the Eldar war god, Khaine. The true identity of the *Eliarenath's Gift* was never discovered.

Gothic War Training Dogma

Eldar attack craft are highly effective at their duties, as are all Eldar machines of war. This problem for our vessels is further compounded by the ability of Eclipse class cruisers to avoid attack almost indefinitely, using their much greater

speed to evade any attacker. If a vessel or squadron does manage to close with the Eclipse it suddenly finds itself faced with the cruiser's deadly pulsar lances, which can cause considerable damage to any kind of target. When used offensively, the Eclipse is able to attack swiftly, deploying its bombers within short range of their targets so that the enemy has little chance of intercepting them. Eldar fighters can also thwart most attempts to subdue the Eldar attack with bombers or torpedoes. The destruction of Eclipse class cruisers in the Eldar fleet should be of paramount importance in any battle plan.

"They came from nowhere. One minute the screens were clear, the next we had Eldar strike craft all over us. We scrambled all our available fighters but they were being destroyed as soon as they cleared the launch tubes. We never even saw the carrier ship. Until then we thought we'd ambushed a pirate patrol screen. They must have been laughing at us the whole time."
- Sub Admiral Skalle, former commander of Battlegroup Ephesus

+++Message Transmitted: 1574999M41
+++Encryption Cypher: Gold
+++Classification Rating: Senioris
+++Ref: IRYC/9745/G6
+++File With: Eldar/ Starcraft
+++Crossfile: Piracy/ Xenocide/
Alien Technology.

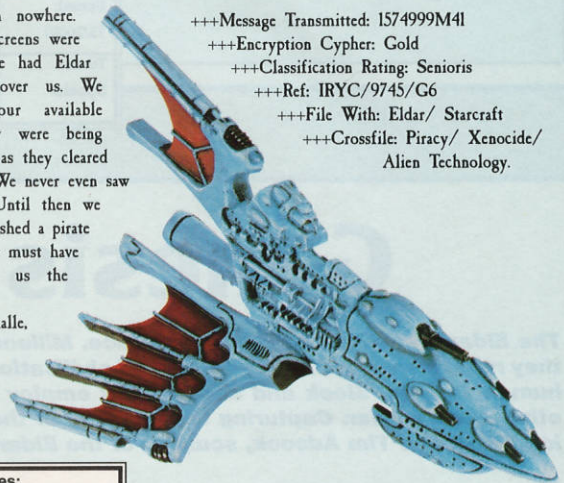

Class:		Eldar Eclipse Class Cruiser			Points:	250	Notes:
Type/Hits:	Armament	Rng/Spd	Firepower/Strength	Arc			
Cruiser/6	Keel Launch Bay	Darkstar: 30cm Eagle: 20cm	4 squadrons	-	Armour: 4+		
Speed: 10/20/25	Prow Lances	30	2	Front	Shields: Holofields		
Turns:					Turrets: 0		
Special							

Eldar Hellebore class frigates – Star Serpents, Voidwings, Children of Moech

The sheer versatility of Hellebore squadrons is the most dangerous threat they pose to any Imperial fleet. With a mixture of torpedo, lance and standard weaponry, Hellebores are able to deal with almost any threat and can change their role in the fleet at any given time. One may put up flights of fighters to protect against torpedo attacks, only to be destroyed by combined lance and battery fire. One's escorts may provide close protection against short-ranged attack only to be destroyed by long-range torpedo fire. In the experience of many of our fleet commanders, it is best to take the offensive and hunt them down with your own escorts. However be

ware, as lone squadrons are likely to be pounced upon by an opportunistic Eldar commander, so always ensure your formations provide each other with mutual support.

"We will destroy you now, not for what you have done but for what you are capable of."
- Lord Dael Starborn at the Battle of Gethsemane.

+++Message Transmitted: 1574999M41
+++Encryption Cypher: Gold
+++Classification Rating: Senioris
+++Ref: RT39B6
+++File With: Eldar/ Starcraft
+++Crossfile: Piracy/
Xenocide/ Alien
Technology



Class:		Eldar Hellebore Class Frigate			Points:	75	Notes:
Type/Hits:	Armament	Rng/Spd	Firepower/Strength	Arc			
Escort/1	Prow Pulsar	30	1	Front	Armour: 4+		
Speed: 10/20/30	Keel Torpedoes	Spd 30	2	Front	Shields: Holofields		
Turns:	Prow Batteries	30	1	Front	Turrets: 0		
Special							

Eldar Hemlock class destroyers – Furious Angels, Devils of the Stars

Like all Eldar escort ships, the Hemlock is considerably well armed for its size. Built around a powerful lance, the Hemlock is perfectly adapted to hunting down opposing escorts. Squadrons of Hemlock class destroyers can easily outpace enemy frigates and other escorts, quickly bringing them into range of their pulsar lances. One

salvo of fire is usually sufficient to destroy an equally-sized enemy squadron before the Hemlock squadron rapidly breaks off to evade a counter-attack. The only real weakness found is a lack of crew, as the Hemlock uses almost all of its power output to generate the pulsar beam. This leaves the vessel highly vulnerable to boarding actions. Unfortunately manoeuvring into position whereby a boarding action can be launched is problematic at best and nigh-on impossible against an experienced squadron commander.

Note: As outlined above, the Hemlock class destroyer is virtually defenceless in a boarding action. Similarly, there are no accounts of a Hemlock class ever initiating such an action.

+++Message Transmitted: 1574999M41
+++Encryption Cypher: Gold
+++Classification Rating: Senioris
+++Ref: JKHO8D
+++File With: Eldar/
Starcraft
+++Crossfile: Piracy/
Xenocide/ Alien
Technology



"I have seen far worse than the death that lies before me. I shall not surrender."
- Karlaen Shadowbound.

Class: Eldar Hemlock Class Destroyer				Points: 40	Notes: Special boarding rules.
Type/Hits:	Armament	Rng/Spd	Firepower/Strength	Arc	
Escort/1	Prow Pulsar	30	1	Front	Armour: 4+
Speed: 15/20/30					Shields: Holofields
Turns:					Turrets: 0
Special					

Genesis of the Eldar

The Eldar are an incredibly ancient race. Millennia before the Imperium of Man ever spread out amongst the stars, they ruled a vast and highly developed civilisation. All Eldar ships are unimaginably advanced in comparison to crude human vessels. Sleek and deadly, they employ far superior technologies and are significantly more efficient than other ships of war. Capturing the essence of these superb craft in miniature form was always going to be a tough job. We asked Tim Adcock, sculptor of the Eldar fleet, how he did it.

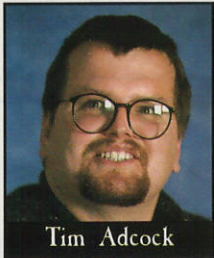

Tim Adcock

Tim Adcock: When the project was given to me, I thought very hard about how I was going to treat the Eldar. We knew what we wanted; they had to look fast and sleek, very predatory and completely unlike the human ships. Jes Goodwin gave me a stack of sketches that he had done years before for all kinds of ships, and there was one in particular that just clicked. It was perfect for what I wanted so I took the sketch and began to work on it. The Eldar that Jes drew were very organic and it had been decided that we wanted a more technological feel to the new stuff. I produced a few sketches of my own and really just worked from there.

The first ships to be done were all the escorts. They were completed relatively quickly and I thought that the cruisers would be finished well before the artwork was done for the rulebook. In the end though, other work held me up so that when Paul Smith did all the technical drawings, I hadn't even started on the big ships. This led to quite a weird situation where Paul was drawing pictures of models that didn't exist yet! Paul's technical drawings ended up as the concept sketches for the cruisers. Even though I was working from finished artwork, I could still interpret the drawings in my own way – I used them as a loose guideline rather than a rigid brief. Obviously I kept to the same general layout, but a lot of the detailing was left quite open for me. The Eldar have been an interesting challenge, definitely a lot of fun to do!

▼ The original sketch by Jes Goodwin that gave Tim his inspiration. These were drawn in mid 1990 – even as long ago as that, Jes was designing concepts for spacecraft!

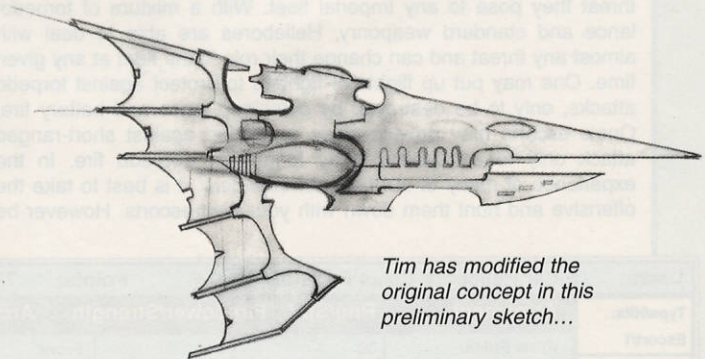
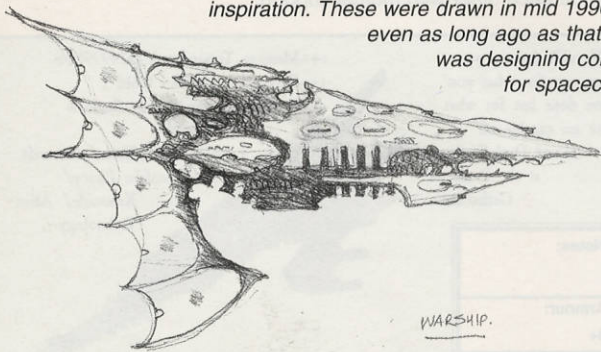

Tim has modified the original concept in this preliminary sketch...

August 1990

July 1998

Eldar Nightshade class destroyers – Blades of V'enna, Storm of Khaine, Flashing Death

As effective as our own Cobra class destroyers may be, their usefulness pales in comparison to the capabilities of the Eldar Nightshade. Astonishingly fast and extremely manoeuvrable, a Nightshade is able to deploy its highly destructive torpedoes almost anywhere they are required on the battlefield. This is coupled with the highly advanced nature of the torpedoes themselves, which seem able to detect even the weakest energy emission. These torpedoes are also obscured from targetting matrices by the sophisticated holofields which are also used to protect all Eldar vessels.

"To become as one with the winds of space and strike with the speed of the sandsnake, that is the beauty of the Nightshade. Harmony in design and elegance of function must be the cardinal virtues of all wargear, and nowhere is the aesthetic so gloriously blended with the efficient, as in this most versatile warship."

– Karlacn Shadowbound.

+++Message Transmitted: 1574999M41
+++Encryption Cypher: Gold
+++Classification Rating: Senioris
+++Ref: ERR/OYN/56
+++File With: Eldar/
Starcraft
+++Crossfile: Piracy/
Xenocide/ Alien
Technology



Class:		Eldar Nightshade class destroyer			Points:	40	Notes:
Type/Hits:	Armament	Rng/Spd	Firepower/Strength	Arc			
Escort/1	Keel Torpedoes	Spd 30	2	Front			Armour: 4+
Speed: 15/20/30	Prow Battery	30	1	Front			Shields: Holofields
Turns:							Turrets: 0
Special							

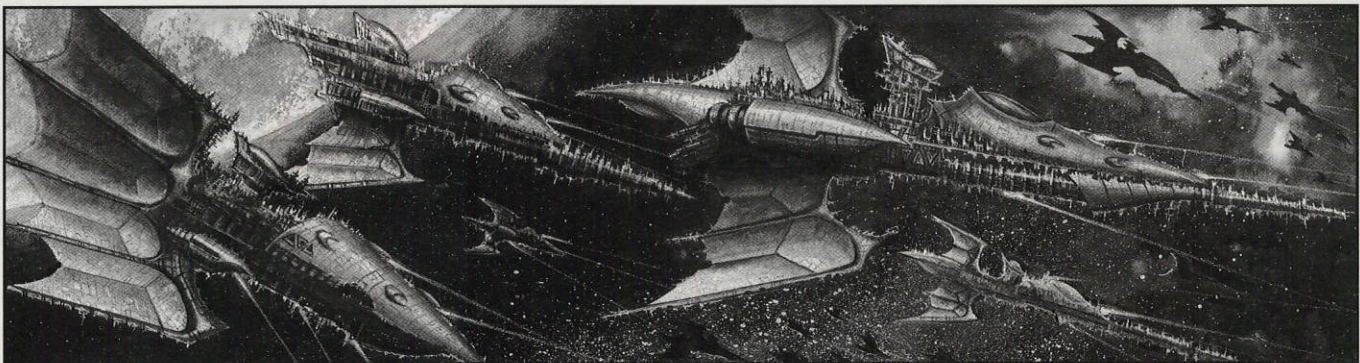

Paul Smith

Paul Smith: *It was strange trying to second-guess Tim over the Eldar cruisers. He showed me some of his sketches and obviously I had already seen all the smaller ships. I took his sketches and did some of my own, and every so often I would go and chat to him, show him my latest sketch and look at what he had been doing in the meantime. We were really just bouncing ideas off each other. I didn't want to tie him down too much with my drawings so I left the final pieces fairly vague so he could interpret them any way he wanted to. Tim had a very strong idea of how he wanted all the ships to look, and it was just a case of keeping a unified look to the craft while making them all recognisably different.*



...which he used as a guide for the finished ships...

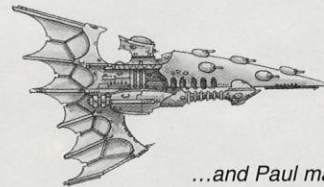

...and Paul made his technical drawings from – this is an Aconite class frigate. The Eldar cruisers were also drawn at this time but not actually made as models until February 1999!

September 1998

November 1998



BATTLEFLEET GOTHIC™

SPACESHIP BATTLES IN THE 41ST MILLENNIUM

Battlefleet Gothic, the game of spaceship combat, is set during the Gothic War in the 41st Millennium; a grim time when the Imperium of Man battles for survival in a hostile galaxy. Battlefleet Gothic allows you to command fleets of warships in deadly conflict among the stars, though whether as Mankind's saviour or its destroyer is up to you!

Available now, the Battlefleet Gothic boxed game contains everything you'll need to get started. You can choose to command the fleets of the Imperium or one of its deadly enemies. The game provides the rules, scenarios and all the fleet lists you need to fight a battle, and guides you through how to paint the highly detailed, plastic Citadel Miniatures spaceships included in the box and then how to put together your own Battlefleet.

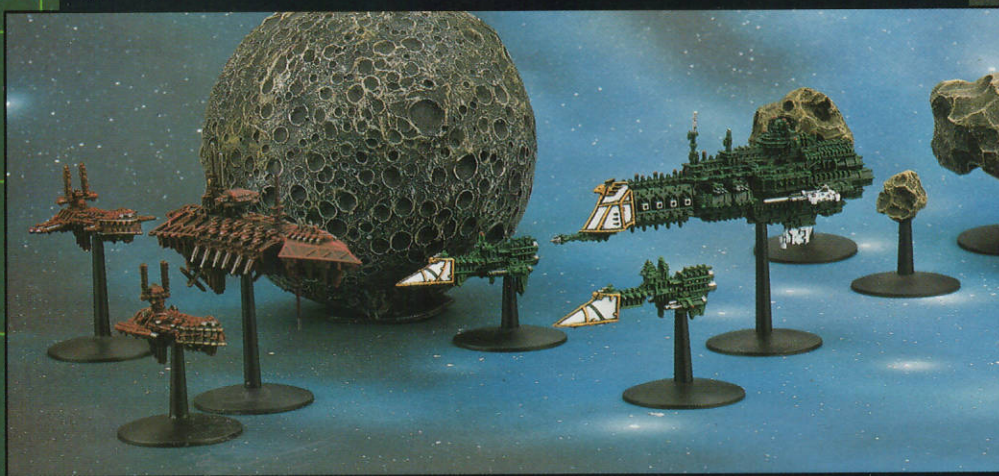

▲ Using a moon for cover, the blood red Chaos fleet prepares to unleash a devastating broadside on the unwary Imperial fleet.



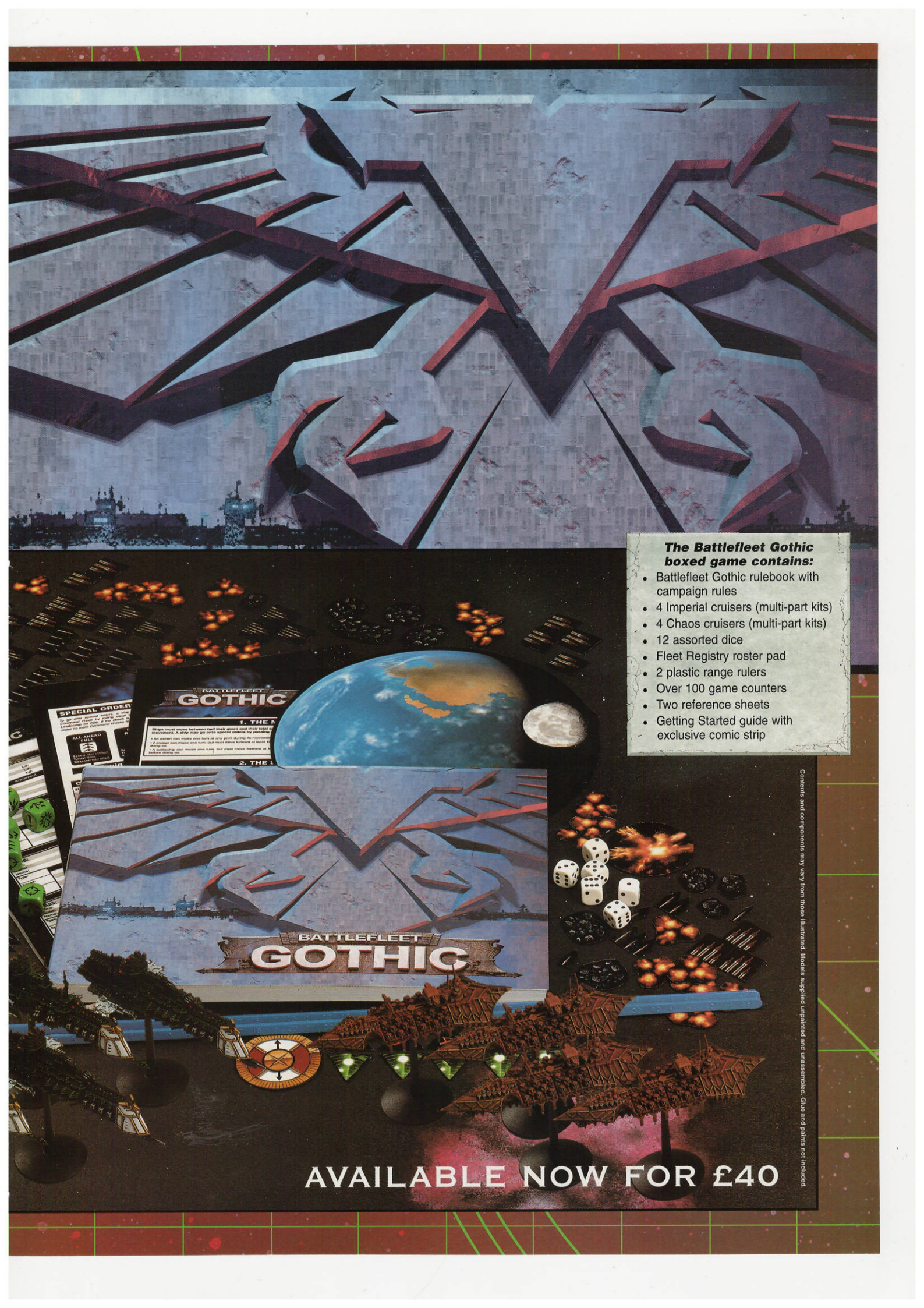

The Battlefleet Gothic boxed game contains:

- Battlefleet Gothic rulebook with campaign rules
- 4 Imperial cruisers (multi-part kits)
- 4 Chaos cruisers (multi-part kits)
- 12 assorted dice
- Fleet Registry roster pad
- 2 plastic range rulers
- Over 100 game counters
- Two reference sheets
- Getting Started guide with exclusive comic strip

Contents and components may vary from those illustrated. Models supplied unpainted and unassembled. Glue and paints not included.

AVAILABLE NOW FOR £40

BATTLEFLEET GOTHIC

Fighting the Eldar

*Tactics and dogma for the Imperial commander
when engaging these most perfidious of aliens, by Fleet Admiral Jim Butler.*



Jim Butler

A Designer's View of the Eldar, by Jervis Johnson

The design brief Andy Chambers gave me for the Eldar in Battlefleet Gothic was satisfyingly straightforward and to the point. "Make sure that they're annoyingly gittish, Jervis," was Andy's decree, and I've done my best to go along with his desires!

What Andy meant was that the Eldar should be an elusive and frustrating foe to fight against; an opponent that relied on manoeuvre and speed to achieve their ends rather than simple brute force. The main way that I achieved this was to allow the Eldar to move, shoot, and then move again (an idea first used by Nigel Stillman for the High Elves in the old 'Man-O-War' game).

However, there were a couple of other elements I wanted to incorporate into the rules. First of all, the Eldar use solar sails rather than warp engines to provide the power for their ships. I've reflected this in their rules by varying their move depending upon their attitude to the nearest star; basically, if an Eldar ship is positioned so that its sails are facing the sun, it will move faster. This ties in nicely with the special double move, and also encourages the Eldar player to think about attack angles much more carefully.

As well as having faster and more manoeuvrable ships, all Eldar weaponry is more accurate than that of other races. The disadvantage (apart from the high points cost) is that all the weaponry is forward firing and short ranged.

The final thing I wanted the rules to reflect was that, while an Eldar ship is very hard to hit because of its sophisticated holofields, they are also very fragile. These two linked aspects of the Eldar are reflected in the modifiers that apply to attacks on Eldar ships which make them hard to hit, and the rule that makes it easier to score critical hits on Eldar ships.

Jervis Johnson

I've fought a few battles against the Eldar now with my Imperial fleet, and while I've enjoyed some success, I think this has been more to do with my opponents' lack of experience, than my own tactical genius. Still, I think I've learnt a trick or two, and I've spent many a lunchtime ruminating on anti-Eldar tactics with Gav and Andy. Eldar fleets are difficult to use, but in the hands of a skilled commander, they are extremely difficult to fight against. Even in battles where I've come out on top, I've never felt totally confident when fighting Eldar. Here are my tips for Imperial commanders, but Chaos warlords should be able to adapt most of the ideas for their own benefit (curse their rotten souls!).

A New Way to Fight

Because Eldar ships work in a different way to conventional opponents (like Chaos or Orks – see Jervis' design notes on the left), you'll have to develop different tactics to fight them. The usual tactic of forming up into a battle line won't work against Eldar for the following reasons...

Firstly, you can normally predict roughly where the enemy ships will be in one or two turns' time. The opposing commander may attempt to manoeuvre more rapidly than you anticipate, but to do so he will have to use special orders, which will cut down his firepower, and make using special orders easier for you. This just isn't the case with Eldar, if you attempt to bring your ships into line, you are just playing into the Eldar commander's delicately-manicured hands, because he can outmanoeuvre your entire fleet in one go.

The second reason it's normally best to mass your ships is the way shields work. Battlefleet Gothic is very finely balanced in that a single ship will find it very difficult to do more in one turn than simply drop the shields of a ship of a similar class, and so conventional tactics tend to revolve around concentrating firepower from several ships on one target at a time. Eldar holofields work differently, so it's not necessary to concentrate your attacks. In fact it's often a good idea to target as many different Eldar ships as possible, in order to try to force them onto 'Brace for Impact' orders (reducing their firepower next turn).

My advice, then, is to fan your fleet out to cover as much of the board as possible, and make good use of planets to help you turn. If it will get you into a firing position, bite the bullet and use 'Come to New Heading' special orders. Although it reduces your firepower, you have to get in your attacks when you can. Don't make the mistake of thinking you'll be in a better firing

position next turn, as the odds are the Eldar ships will be nowhere near where they were the turn before, and with their fearsome firepower, will probably have wreaked havoc on your fleet before zipping off and leaving you stranded – in a game against Iain Compton, one Shadow class cruiser destroyed my Dauntless in a single salvo! (*Heh, heh, heh... – Iain*).

Finding Your Fleet

It has to be said that some ships are more useful than others against Eldar (this is why having a big fleet to choose from is an advantage). Escorts and light cruisers can make 90° turns, which makes it much harder for the Eldar fleet to outmanoeuvre you. Escorts have the added advantage of being able to turn before they move. The most useful of these, I've found, is the Sword class frigate, as it combines this manoeuvrability with weapon battery armament. I've found them best used in mutually supporting pairs, so that if one pair gets attacked it can Brace for Impact, and hopefully survive. In the next turn, the other pair can still fire at full effect.

Another way of fighting Eldar is to out-range them. If you include some ships with long ranged weapons (45cm or over), you'll make it very difficult for the Eldar commander to launch an attack without putting his ships at some risk, as all Eldar weaponry has a range of 30cm. Battleships, battlecruisers and Tyrant class cruisers are all good for this, but special mention should be made of the Emperor class battleship. Not only is it bristling with long ranged weapon batteries, it's also the only Imperial ship that can launch assault boats. These are deadly against Eldar escorts, and with their 30cm speed, are less vulnerable to Eldar fighters than your slow flying bombers. On the subject of fighters, one tactic that you might want to try is launching waves of fighters as torpedo screens for your capital ships as Eldar torpedoes are far more devastating than Imperial equivalents, and a single salvo is easily capable of crippling a cruiser.

Well that's all I've got to offer. Fighting Eldar fleets can be a very frustrating experience, but never lose heart – battles against the Eldar can twist and turn faster than a Cobra destroyer. While they can dish out an awful lot of firepower, all it takes is a few lucky shots on your part and the Eldar fleet will often just vanish.

Eat vacuum, you disgusting alien weirdoes!

Jim Butler

WHOOOPS! Battlefleet Gothic Errata

With the inevitability of an inevitable thing, a few errors have been spotted in the first print run of the Battlefleet Gothic rulebook. These will get cleared up in later runs, but for those of you who already have a copy – sorry, but we made a boo boo on Scenario 10: Fleet Engagement. The maps for Fleet Engagement were supposed to be toned in dark grey and white to show the opposing set up areas – but they all turned out white! We've reproduced the maps correctly here, so get out your pencils and Gothic rulebooks, turn to page 80 and shade the appropriate bits.

On the maps that follow, the various areas are shaded to correspond with the table from the rulebook (which is also shown here for you). The solid black arrows show the direction that all ships in a particular division must be facing.

It's probably worth giving a brief example of how the table works, as at first sight it can seem quite confusing.

Let's say that you choose to deploy in a wedge formation while your opponent opts for a sphere. Looking at the table, two different maps are indicated. You roll off as described in the rulebook and we will assume that you win. You have the choice of either map A or map C.

Whichever map you choose, you will deploy on the white area while your opponent will have the dark grey part of the same map. If you look at the deployment table from your opponent's point of view, you will see that he has the same choice of maps and will have the dark grey deployment zone, leaving you with the white.

YOUR CHOICE	OPPONENTS CHOICE		
	Sphere	Wedge	Cross
Sphere	B	A(d.grey)/C(d.grey)	A(d.grey)/D(d.grey)
Wedge	A(white)/C(white)	D(d.grey)/D(white)	B
Cross	A(white)/D(white)	B	B

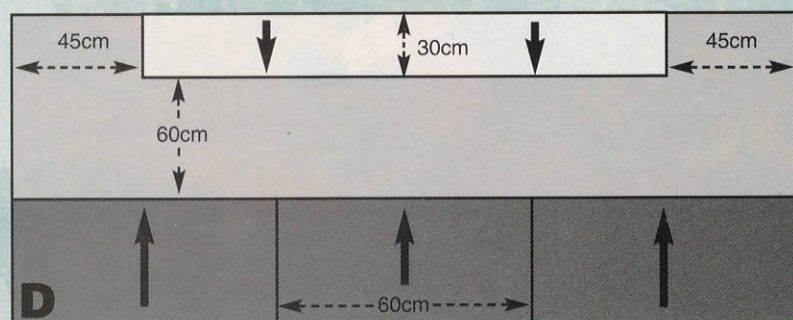
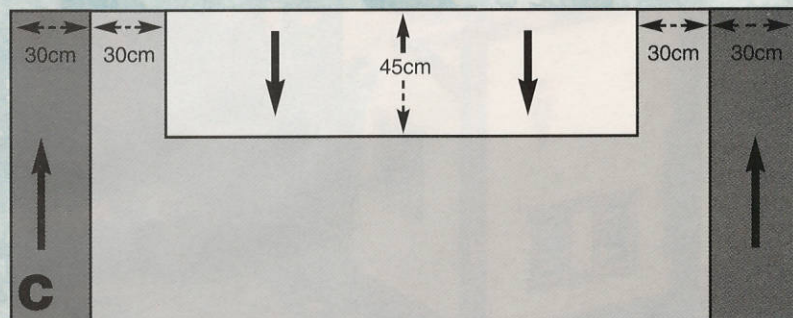
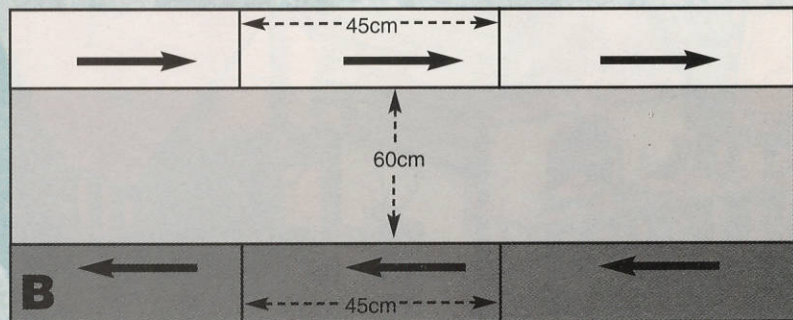
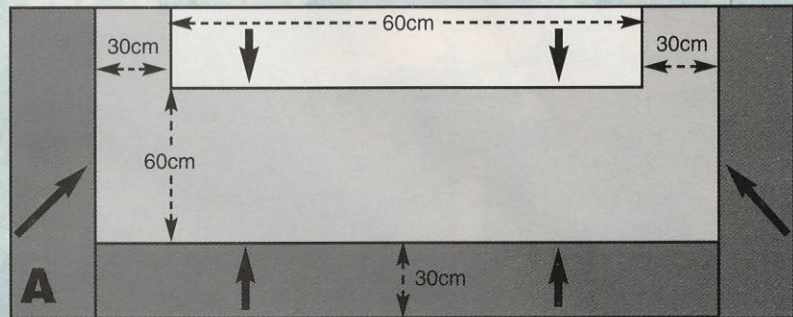

#ANDY/C

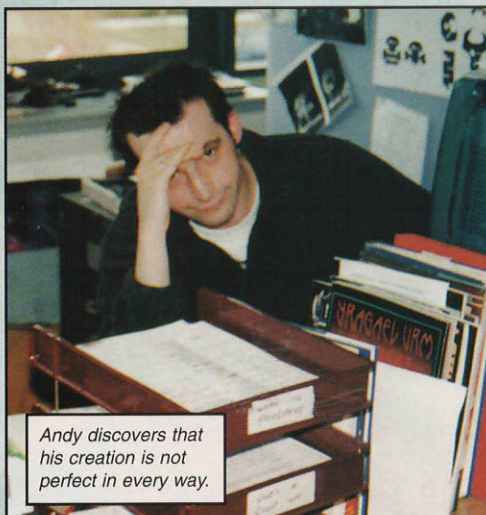

Andy discovers that his creation is not perfect in every way.

The Mines of

In the far off city of Barcelona, you can find the Games Workshop Spanish Studio, where they toil away translating our products for the thousands of Spanish-speaking gamers across the world. You can also find this amazing Dwarf mining village built by Spanish Mail Order Troll, Lluís Oliva. The chaps at GW Spain sent along translator Jordi Ferré to find out exactly how Lluís made this superb diorama.

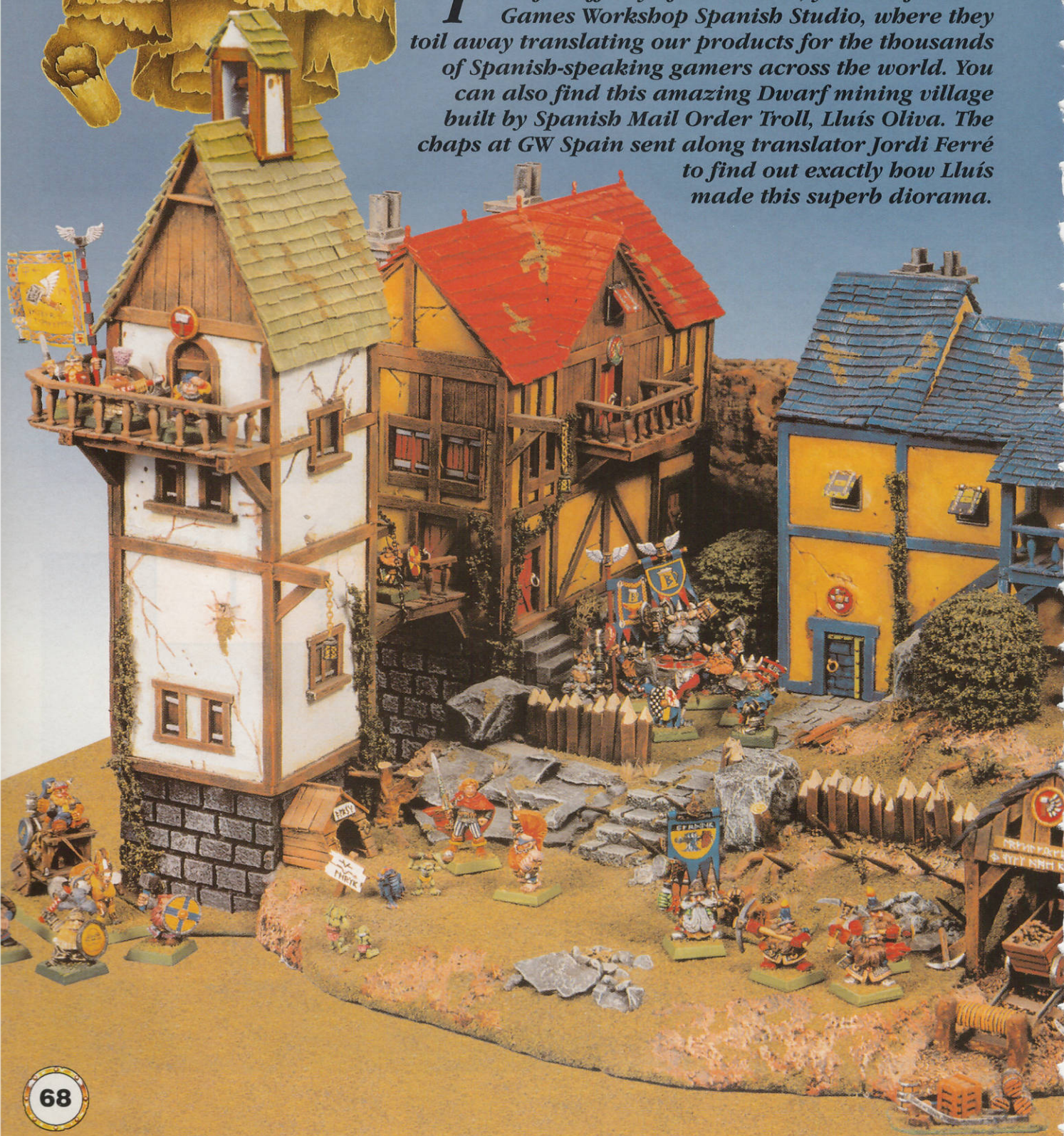

King Zak-Lomok

Built by Lluís Oliva

GAME
WORKSHO
MAIL
ORDER
TROLL

Lluís built the main tower of the village, like the rest of the buildings, from boxes stacked on top of each other. He used cork tiles with a few stones carved into them to represent the foundations, and the whitewashed walls of the tower were modelled using 2mm artboard, with one of the smooth outer layers torn off to give a natural, rough texture. Over this basic structure he added window frames, timber beams and the balcony, all made from balsa wood.

The places where the walls are crumbling away were made by carefully drilling away the artboard, and painting with a watered down mix of Bronzed Flesh and Skull White. Finally, Lluís stuck on a few patches of flock to represent moss growing on the wall.



Dwarf villages, especially those that have sprung up around a mine, are mainly found in mountain areas, so rocks are fairly common (*you don't say!* – Paul Sawyer). Lluís has used real stones for the rocks in the middle of the village (available in most back gardens), and sculpted the bigger, irregular boulders out of ready-mixed filler.

To bring the scene to life, Lluís has added a lot of small details, like stacked boxes and barrels, and a 'dog kennel'.

The mines are the life-blood of the village and where most activity takes place. Both mine-shafts have been dug deep into the mountainside, and are supported with pit-props made of balsa wood strips.

WARHAMMER



In the larger of the two mines ('Dead Bones Mine', as the sign says), the Dwarfs have constructed a railway to make the digging easier. Lluís has used rails from a model train set, and made the truck from balsa wood, with plastic shields for the wheels. The truck even contains scraps of metal to represent the ore that the Dwarfs have mined!

The secondary tunnel cuts straight into the bedrock of the mountain. It was built from offcut pieces left over from making foundations and boulders for the rest of the village.

Lluís does not usually include miniatures in his dioramas, but the warriors from his Dwarf army insisted on posing for our photographer. So Josef Bugman and a few of his trusty Dwarfs have gathered in the main square of the village.



Bugman's shield is made of balsa wood, with the details carefully crafted from pieces of metal. The regimental musician is a converted plastic Dwarf, carrying bagpipes modelled from putty.

WARHAMMER® 40,000

WATCH THE SHADOWS



by Kabal Lord
Gav Thorpe

They're fast, deadly and almost impossible to catch. Just when you think you've cornered them you realise you've fallen into their trap. Now the shadowy Mandrakes have been unleashed – Dark Eldar who crave nothing but flesh and blood. We let Kabal Lord Gav Thorpe explain all.

DARK ORIGINS

The Dark Eldar are synonymous with shadows and darkness, but among them there are some who are even more adept at stealthy murder – the Mandrakes. Those few who know about the Dark Eldar and their origins have hypothesised greatly on the nature of the Mandrakes, and there are two main schools of thought. There are those who believe the Mandrakes (and the Haemonculi for that matter) have been altered by their constant exposure to the warp. This mutation allows the Mandrakes to shift their physical presence slightly out of real space, thus allowing them to move virtually undetected. Other experts are convinced that the Mandrakes, and the Haemonculi with them, were the very last of the Eldar to escape into the Webway during the cataclysmic psychic explosion of the fall. Torn between the physical realm and the half-immaterial world of the Webway by the supernatural forces unleashed at the birth of Slaanesh, the Mandrakes are neither wholly physical nor totally incorporeal. It will never be known if either of these theories are correct, or if the truth is something else entirely.

This transformation has been passed on through various bloodlines, so that most of the Kabals contain a number of Mandrakes among their ranks. It is evident that the Mandrakes hold something of a mixed position in Dark Eldar society. On the one hand they are regarded as shining examples of Dark Eldar society – totally treacherous,

merciless and concerned only with instant self-gratification. Unfortunately, they are almost mindless in some respects, craving raw flesh and blood for sustenance and showing little true intellect or sophistication. This is in contradiction to the highly attuned sensuousness and subtle aesthetics that all Eldar admire. The arrogant Dark Eldar see themselves as perfect in all respects, and the fact that their species can spawn such hideous creatures is something of an embarrassment to them.

LIVING SHADOWS

Due to their peculiar nature, Mandrakes are probably the best stealth unit in the Warhammer 40,000 game, outclassing even Eldar Rangers. The fact that they are always deployed on the table right from the start can give you a certain edge in some missions. For example Rescue normally only allows you to deploy Troops units (whilst Mandrakes come from the Elites section). If used to its best advantage this superiority can be used to overwhelm the enemy before too many of their reserves can arrive.

When you deploy, you place three Mandrake models in different positions, and during the game you choose which model actually represents their real position – so they have a habit of always being in the right place at the right time. This can be used to press home an advantage or to cover a weakness in the rest of your army. For example, if one of



Mandrakes emerge from the shadows to catch the Dark Angels in a lethal crossfire.

your Wych units gets an opportunity to charge the enemy, the sudden appearance of some Mandrakes to help them (and add to the Wyches' numbers) can swing the fight even more in your favour. Alternatively, if you are facing an army with elusive, fast moving units such as Bike squadrons, your Mandrakes can be spread across the battlefield to reveal themselves wherever the bikes move to.

In my opinion, the Mandrakes' ability to move totally unseen makes them superb for catching enemy units in a crossfire. I've found in my battles that Dark Eldar work best when they bide their time while moving into position and then pounce on the enemy all at once, sweeping them away in a single turn of horrendously vicious shooting and close combat. Whilst you are organising this attack the Mandrakes can move around the rear of the enemy army, totally impervious to harm thanks to their abilities, and then when the assault is launched they are revealed, ready to catch any breaking enemy units in a lethal crossfire. This is particularly splendid when fighting

against Space Marines, who would otherwise automatically regroup thanks to their pesky 'They Shall Know No Fear' rule! No other unit in Warhammer 40,000 can get behind the enemy in total safety in this way (although watch out for the Mandrakes being caught in a crossfire themselves in future turns).

SHADOW WATCHING

A word of warning, though. Mandrakes cannot use fleet of foot whilst hidden, or be carried on a transport. This means that they may actually move more slowly than the rest of your army. You should avoid this if possible, holding back your other units out of sight of the enemy until the Mandrakes are in position to join in your massed attack.

Well, that's enough of my wittering. Remember – death stalks in the shadows. Happy Gaming!



DARK ELДАР MANDRAKES Sculpted by Gary Morley



FIGHTING DARK ELДАР

Been overrun? Out manoeuvred? Hunted down? Trapped and dragged to the dark realm of Commorragh in chains? Yes? – well so have we. We took a quick poll of some of the Studio WH40K commanders that have faced the Dark Eldar, and asked them if they had any tips on how to bring these deadly foes to heel.

"What! Give you tips on how to beat me? Bwah-ha-ha-ha!"

Nick Davis, Dark Eldar Lord

"The nastiest Dark Eldar close combat troops (in Nick's army this would be the Archon and his Incubi bodyguard) often go around in a Raider so they can get into combat quickly and in the most damaging place. Make it your priority to shoot down this Raider while it is still well away from your lines. Your opponent's expensive squad will then have to run right across the battlefield as you pour all your firepower into it."

Graham Davey, Chaos Lord

"I play Eldar, so I find that the best way of taking out Dark Eldar is simply through weight of numbers. I take as many Guardians as I possibly can. After rolling about 30 or 40 shuriken catapult shots, I find that there usually aren't enough Dark Eldar left to worry me! The main thing is to stop them getting close enough to charge you – I find that killing them all first is the best way of achieving this. Just don't forget about their Fleet of Foot rule – it can really catch you out if you are not expecting it."

Iain Compton, Eldar Farseer

"Take Space Marines."

Paul Sawyer (aka Fat Bloke), White Scars ilKhan

"Imperial Guard have a tough time against Dark Eldar. In order to stand a chance against them you must target their transports first. Pay very special attention to the Archon and his retinue. If they reach your lines in their Raider, your army will soon die in particularly nasty ways! Always take searchlights in case you end up fighting at night – you must see to shoot. Consider taking Ogryns as effective counter-attacking troops – they're big and fun, and kill Dark Eldar scum real quick!"

Rowland Cox, Imperial Guard Captain

"Shoot da close combat stuff, close combat da shooty stuff. They go squish real easy if you shoot 'em or 'it 'em!"

Adrian Wood, Ork Grand Warlord

"I've only played against Dark Eldar on a few occasions but I have watched a good few games and from this I've deduced one very important thing: **SHOOT THE ARCHON**, and then shoot him some more just to be sure. A well equipped Archon can defeat almost any opponent in close combat (he's especially dangerous because his high Initiative means he will almost always strike first). Most Archons have the sense to carry a shadow field, so the best way to take him out is shoot him with as many basic weapons as possible. Hit him enough times and he's bound to fail his save (therefore taking a wound and losing his valuable 2+ invulnerable save). The only disadvantage of this is that you'll probably have to kill the Archon's entire bodyguard first – not easy to do as the Incubi have 3+ saves."

Simon Shuker, 1 of 634, Tyranid Hive mind



Nick Davis' Mandrakes advance through his ruined settlement (more about that in a future issue). Nick took their description of 'shadow-skinned' literally, and painted their skin Midnight Blue (matching his Warp Beasts).

THE SHADOW



by Tony Cottrell

Some of you might remember Tony Cottrell from his vehicle conversions featured in very early issues of White Dwarf. He has scratch built or converted Vindicators (WD118), Spartans (WD119), Sabres (WD120), Scout Titans (WD120), Ork Blitzwagons (WD128) and many more. Well he hasn't stopped. Here is one of his latest projects – a Dark Eldar Raider, named the Shadow.

Attack the enemy where he is weakest.

Where he is strong, draw him on until he is trapped.

Where he is unsure, strike quickly and scatter his forces.

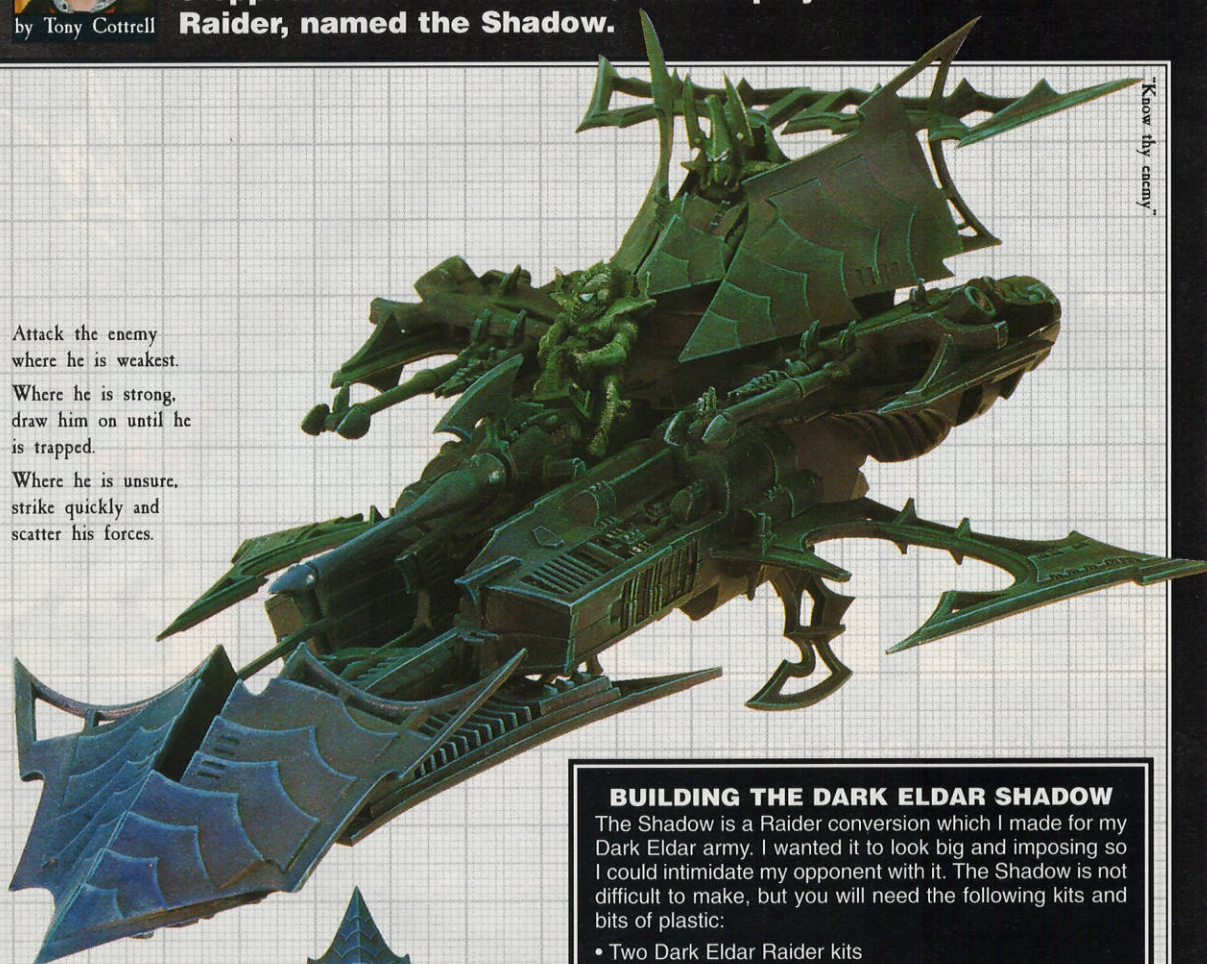

BUILDING THE DARK ELДАР SHADOW

The Shadow is a Raider conversion which I made for my Dark Eldar army. I wanted it to look big and imposing so I could intimidate my opponent with it. The Shadow is not difficult to make, but you will need the following kits and bits of plastic:

- Two Dark Eldar Raider kits
- One Eldar Falcon grav tank kit
- As many Dark Eldar spiky bits as you can get
- A plastic tube (a long plastic pen will do)

As you can see, this is a fairly expensive model to build, if you want to have a go. The complete assembly instructions along with stage-by-stage shots and some ad-hoc rules will be published in Citadel Journal 33.

HOW IT FARED IN BATTLE

The Shadow's first outing on the tabletop was at the recent WH40K Open Day at our own Exhibition Hall here in Nottingham. It took to the battlefield as part of a large Dark Eldar raiding force, against one of the most feared of 40K armies – the Blood Angels. Probably because of its large menacing look, it attracted a large amount of the Marines' fire in the opening turns (I find Imperial players get a bit scared if you turn up with vehicles bigger than theirs!), which sadly caused it to crash and burn. But this distraction was enough for the Dark Eldar to take the initiative and win a great victory against some of the Emperor's finest.

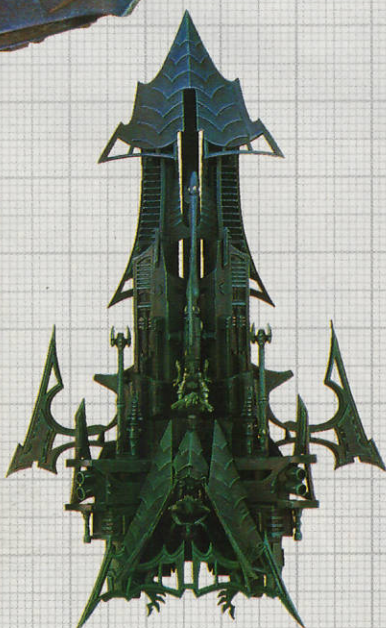

"Whispering Death"

the citadel
Journal

Interested in building your own Shadow? Full rules and assembly instructions in Citadel Journal 33!

MASTER OF BLADES

The Incubi are deadly warriors – their martial prowess is almost legendary. The most deadly of all is Drazhar, Master of Blades, who is released this month, just in time to protect the new Dark Eldar Lord.



Designed by
Chris FitzPatrick

DRAZHAR,
MASTER OF BLADES



Designed by
Gary Morley

DARK ELДАР LORD

DRAZHAR

	Points	WS	BS	S	T	W	I	A	Ld	Sv
Drazhar	90	6	4	4	3	3	6	2(3)	9	3+

Any Dark Eldar retinue may be joined by Drazhar, who takes the place of one of the normal Incubi allowed in the retinue. He must be used exactly as described here, and may not be given any extra equipment. In addition, Drazhar may only be used in a battle where both players have agreed to the use of special characters.

Wargear: Tormentor helm and *Disemboweller Blades*.

SPECIAL RULES

Disemboweller Blades: Drazhar is armed with a unique pair of weapons called *Disemboweller Blades*. These are treated as a power weapon that can cause two wounds for each hit inflicted (this means that two wound rolls are made for each successful hit). Drazhar's extra attack for being armed with an additional close combat weapon is included in his profile above.

Bodyguard: In the assault phase Drazhar may change places with the Dark Eldar Lord whose retinue he belongs to. This represents Drazhar stepping forward to protect the Lord against an enemy attack. This takes place after models have charged into combat, but before any of the close combats have been resolved. The Dark Eldar Lord and Drazhar simply change places, and the close combats are then resolved as normal. Note that this may happen in either player's turn.

Brazhak fired his slugga into the face of one of the pointy-cars, laughing coarsely at the carnage he and his Boyz were wreaking. Grabbitz and his big gunz had taken down the flying kart, leaving the enemy boss stranded in the middle of the battlefield. Brazhak's mob had smashed their way through the enemy line and were ready to fall upon their hapless foe. The Ork Nob clenched his power claw and grinned evilly as he shouldered his way through the mob towards the pointy-eared leader who was standing dumbstruck amidst the turmoil. Yelling incoherently, he brought his fist back for the killing blow.

Suddenly, a blade came out of nowhere, slicing through his arm just above the elbow. Brazhak looked round and saw a tall pointy-cars, decked out in armour. Before he could bring up his slugga for a shot, the enemy attacked again, its lethal blades cutting across the Nob's midsection and chest, spilling blood everywhere. Feeling even his considerable strength leeching from him, Brazhak fell to his knees. Looking up into the mask of the warrior, his defiant glare was met by two pitiless, glowing orbs. Then the blades slashed back and forth one final time, and Brazhak knew no more.

Drazhar leaps to the defence of the Archon, as Khorne Berzerkers charge.



DOGS
OF WAR
CHARACTERS
FOR HIRE

WARHAMMER ARMIES Dogs of War™

DOGS
OF WAR
CHARACTERS
FOR HIRE

BURN THE WITCH!

By Tuomas Pirinen

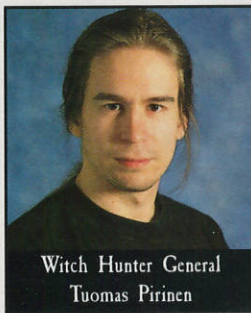

Witch Hunter General
Tuomas Pirinen

In the grim reality of the Old World, secret cults plot the coming of Chaos, Sorcerers meddle with dark magics and the Undead stalk the earth. But there are those who battle against the unnatural horrors of the Old World. They are the Witch Hunters – driven men who wander the Old World rooting out evil. Witch Hunter General Tuomas Pirinen opens up his journal and brings us the tale of one of the most grim and haunted of Witch Hunters – Johann van Hal & Wilhelm Hasburg, Priest of Sigmar.

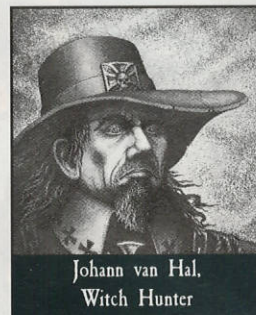

Johann van Hal,
Witch Hunter

DOGS OF WAR CHARACTERS

Just as there are regiments of mercenaries to hire, there are just as many lone freelancers. These individuals wander the Old World, selling their skills to the highest bidder. Many are thieves and brigands, and some are hard bitten mercenaries who will not (or cannot) join one of the many mercenary regiments. There are thrill-seeking Imperial nobles, fanatical Witch Hunters and even specialists such as siege engineers, wizards or assassins.

READY FOR HIRE

The Witch Hunters count as a Regiment of Renown and their points cost is added to the Dogs of War regiment allocation. Regiments of Renown can also be incorporated into your existing Warhammer armies very easily. Just add the regiment's points cost to the allies allocation of your army list.

So with no further ado, White Dwarf brings you the grim tale of the Witch Hunters Johann van Hal and Wilhelm Hasburg.

THE WITCH HUNTERS JOHANN VAN HAL & WILHELM HASBURG

Sculpted by Paul Muller



▲ Wilhelm Hasburg – Priest of Sigmar



▲ Witch Hunter Johann van Hal



Hired by a determined Mercenary General, the Witch Hunters prepare to destroy a foul Vampire Count.

THE WITCH HUNTERS

Witch Hunters are a secret order of scattered men, obsessed with the destruction of Chaos, Undead, mutants, deviants, unbelievers, blasphemers and potentially anyone else except other Witch Hunters. Many people find their fanaticism disturbing and their extreme beliefs threatening, so the Witch Hunters are rarely welcome to stay anywhere for long. Who knows who will fall under suspicion next? A single wrong word may condemn you!

Johann van Hal is perhaps the most famous of all the Witch Hunters of the age, the slayer of Vampire Gunther von Blodfel and the man who purged the haunted castle of Reikwald. Where he comes from or why he has chosen to become a Witch Hunter is unknown. Johann does not talk about his past, and it is unwise to question this grim and moody man about things he does not want to discuss. But those who are well versed in the lore of the Empire know that he shares the name of the infamous Vanhal, the dreaded Necromancer of ancient times. All the descendants of Vanhal have strived to atone for the evil deeds of their ancestor, but without success. For each evil Sorcerer destroyed ten new ones step onto the path of Damnation. For every Vampire slain an entire noble family will be infected with the curse of Vampirism. One can only guess the weight of guilt and angst that Johann carries.

Johann has only one companion, and he is not part of the order of Witch Hunters. He is Wilhelm Hasburg, a priest of Sigmar whose temple was burned by Chaos worshippers. Some say he became insane watching his life's work go up in flames, but none dare to dispute his faith and piety, which he shows with horrific self-mutilation and ceaseless prophecies of the end of the world. It is believed that his faith and continuous prayers protect him from evil magic, and he is certainly able to crush the skull of any blasphemous, using the staff that he found in the ruins of his temple.

When facing supernatural foes, many desperate generals draw the Mark of the Hammer on road signs and town gates, calling the legendary Witch Hunter to come to their aid. Johann will offer his services to anyone who is willing to pay. All the gold that he does not need himself is donated to the church of Sigmar.

So when the forces of Undeath threaten or the darkness of Chaos falls upon the Old World, Johann van Hal and Wilhelm come. They face the most terrible foes without fear, and attack foul Undead or terrifying Daemons with cold fury and hatred burning in their eyes. After the battle they claim their prize and depart without a word – and most men are happy to see them go.

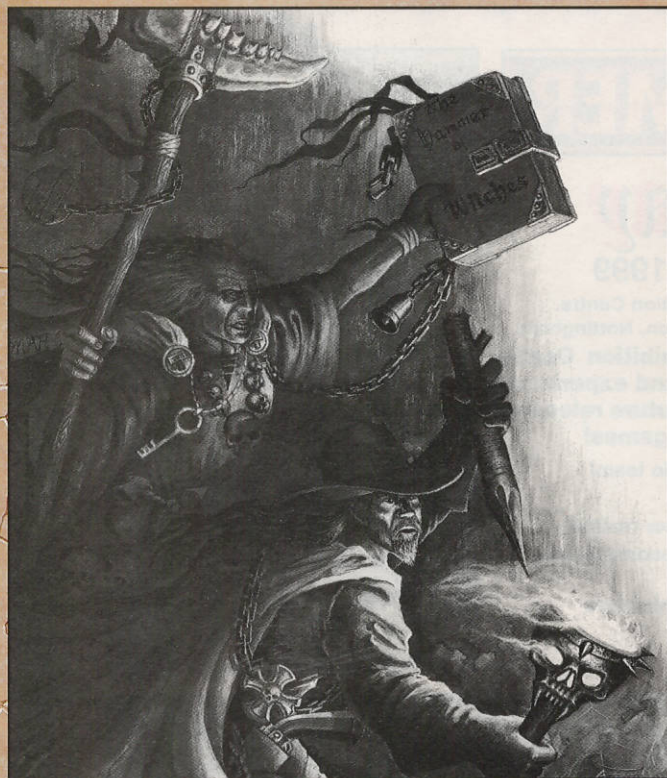

THE REGIMENT

Captain: Johann van Hal.

Motto: Burn them all!

Battle-cry: "It's a witch!" is not Johann's official battlecry, but is often the last thing his opponents hear.

Appearance: Dark and grim. Johann wears a dark cloak and a floppy, black, leather hat. His eyes are bloodshot and full of fanaticism. Wilhelm Hasburg wears the cloak of a Sigmarite priest and carries the great book the 'Hammer of Witches' as well as a staff topped with the jawbone of an ox.

For Hire: All Warhammer armies except Undead, Dark Elves (burn those Witch Elves!), Skaven or Chaos may hire Johann and Wilhelm.

Points: Johann van Hal and Wilhelm Hasburg cost a total of 230 points.

Profile	M	WS	BS	S	T	W	I	A	Ld
Johann van Hal	4	5	5	4	4	2	4	3	9
Wilhelm Hasburg	4	4	4	4	4	2	2	2	7

Weapons/Armour: Johann carries a brace of pistols, hand weapons, an assorted collection of stakes, holy relics and the Stake of Sigmar. Wilhelm is armed with the Holy Staff and carries the great book – the Hammer of Witches.

Armour Save: None (special magical dispel – see below).

MAGIC ITEMS

Stake of Sigmar

Enchanted Item 30 points

This ancient relic is said to be a fragment of the tree felled by Sigmar with a single stroke when the Unberogen tribe started building the city of Altdorf. It was held in the temple of Sigmar at Obersdorf until the town was sacked by Orcs and Goblins and the relic was lost. Now it is carried by Johann van Hal.

The Stake of Sigmar fills Johann with the strength and purpose of Sigmar himself. It doubles Johann's Strength when he is fighting against any Undead creatures or any Daemons. This gives him an effective Strength of 8. Johann may also use the stake against Vampires in hand-to-hand combat. If he does this, a single unsaved wound caused by him automatically slays any Vampire outright.

Holy Staff

Magic Weapon 50 points

Atop this ironwood staff is mounted the jawbone which, it is said, was used by Sigmar when he single-handedly destroyed an army of Skaven. Wilhelm found it buried under the ruins of his temple.

Wilhelm may add +2 to his Strength when fighting in hand-to-hand combat. In addition the staff will automatically wound any Skaven, Daemon or Undead Creature.

SPECIAL RULES

Formation: Johann and Wilhelm always fight together and cannot join any other units.

Psychology: Johann and Wilhelm are utterly dedicated to their work of hunting down Chaos worshippers and Vampires. During the long, lonely years they have met and defeated the most horrifying creatures and blasphemous monsters. Because of their experiences Johann and Wilhelm are immune to psychology. The only exception is that they *bate* all models in any Chaos army and all Undead creatures.

Witch Hunter Weapons: Johann is armed with pistols loaded with silver bullets and a sword blessed by Wilhelm. Thus all his attacks count as magical (negating Daemonic saves and making him capable of wounding ethereal creatures).

Wilhelm Hasburg: Wilhelm is a fanatical priest of Sigmar, obsessed with the destruction of the forces of Undead and Chaos. When he reads the litanies of banishment from his holy book called 'the Hammer of Witches', he radiates an aura of holiness and utter faith. Any Chaos, Dark Magic or Necromantic spell targeted towards him or Johann is dispelled on a D6 roll of 4+.

NOTTINGHAM HQ

BATTLEFLEET GOTHIC™

THE GOTHIC WAR

Battlefleet Gothic Campaign

Saturday 5th June 1999

Games Workshop presents the first ever Battlefleet Gothic campaign. Our purpose built Exhibition Hall will be laid out with loads of gaming tables, arranged to represent the entire Gothic Sector!

Every player controls a fleet as part of a great armada, and will be able to move from table to table, fighting battles for supremacy of the systems in the Gothic Sector. Book your ticket now to decide the victor of the Gothic conflict.



You will need a painted 1,250 point fleet, conforming to the new Battlefleet Gothic rulebook fleet lists. When you order your tickets we will send you full rules and all the details of this incredible day! Tickets for this event are available priced £7 through all Games Workshop stores and from Games Workshop Mail Order (0115 91 40000).

- Tickets on sale from 1st April 1999.
 - Entry strictly by ticket only.
 - Tickets will not be available on the day.
 - Over 16s only, unless accompanied by an adult.
- For more information phone Mail Order on 0115 91 40000.

WARHAMMER

Open Day

10am-4pm 2nd May 1999

Games Workshop Nottingham Exhibition Centre.
Games Workshop HQ, Willow Road, Lenton, Nottingham.
The doors of our Nottingham Exhibition Centre are thrown open for you to come and experience the world of Warhammer, glimpse future releases, and participate in some awesome games!

- See work in development from the Studio team!
- Take part in awesome battles!
- Discover the mysteries of the Warhammer realms!
- Visit Warhammer World and see the awesome Games Day displays!
- See previews of upcoming games and miniature releases!
- Meet the games designers and artists!



TICKETS PRICED £6.00 (INCLUDING ENTRY TO WARHAMMER WORLD). TICKETS WILL NOT BE AVAILABLE ON THE DAY. TICKETS AVAILABLE NOW FROM MAIL ORDER (TEL: 0115 91 40000) OR THROUGH GAMES WORKSHOP STORES.

WARHAMMER

GRAND TOURNAMENT 1999

Saturday 31st July &
Sunday 1st August 1999

As dawn approaches, the massed armies of the mightiest Warhammer gamers in the world gather to contest the greatest prize of all. It is once again time to decide the International Warhammer Champion.

You will need a 2,000 point army conforming to the armies books. When you order your ticket we will send you full rules and all the details for this incredible event.

Tickets are priced £25 and are available from Mail Order or through Games Workshop stores from the 22nd May.

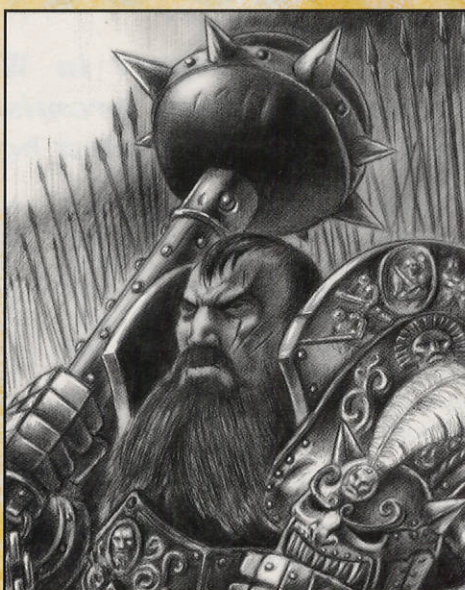

WARHAMMER WORLD THE GAMES WORKSHOP MUSEUM

GAMES WORKSHOP NOTTINGHAM EXHIBITION CENTRE,
Games Workshop HQ, Willow Road, Lenton, Nottingham.

Games Workshop presents the Warhammer World museum featuring awesome, life-size Warhammer 40,000 characters in amazing settings, including Blood Angels Space Marines, Ork dungeon, Space Hulk corridor and Chaos Space Marine battle scene!

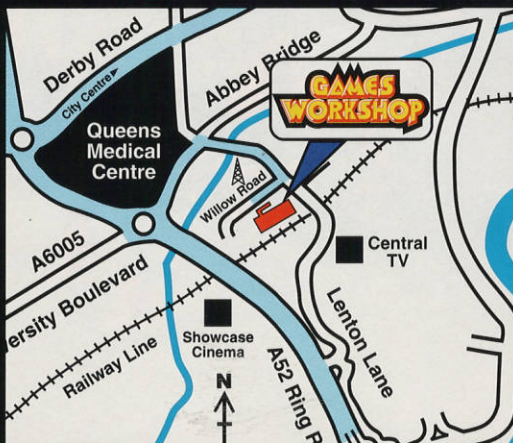

As if that wasn't enough you can also come and see our great selection of massive games displays including the Ultramarines Chapter, Massacre at Big Toof River, the Antoch Plains and of course another chance to see last year's mega display, the Siege of the Emperor's Palace, plus lots more great displays!

ADMISSION £1: Guided tours of the museum are conducted most days at the HQ store. Adults accompanied by gamers under the age of 16 may enter free.

VERY IMPORTANT! Before you set off to visit us, please telephone the HQ store to ensure that the Museum is open and that guided tours are available. Open 7 days a week. Tel: 0115 916 8410

NOTTINGHAM HQ

BAD MOON RISING 2

Following their battle report in WD229 (Bad Moon Rising), Jim Butler and Owen Branham promised us a rematch, so not being ones to let you down, here's what happened. Jim tells all...

Jim: Back in WD229 Owen Branham and I were invited to fight a Warhammer battle report with Orcs & Goblins versus the Empire (being conspicuous owners of those respective armies). Fighting the battle with the Studio armies whetted our appetites for a big, 3,000 point battle with our own armies. Since we'd fought two battles and won one each, we treated this battle as the decider. The battle was fought as a straight fight to the death, with equal armies (no restrictions!).

As I wrote in the original article, I had been very impressed by the performance of my lowly Empire soldiers, so I painted up a couple of extra regiments ready for this battle. While Owen fielded a familiar force, I was trying out some new troops, and hence new tactics.

With my missile troops occupying the high ground, I arrayed my Halberdiers and Swordsman ready to meet the greenskins' charge. Of course, I kept to some of my favourite tactics, including a big regiment of Flagellants to hold the centre of my line, and a couple of volley guns. I also secured the services of that infamous Regiment of Renown – Golgfag's Ogres.

My basic tactic was a classic Empire gambit: whittle down the enemy with missile fire and rely on deep blocks of infantry to hold the (hopefully depleted) enemy, when they finally get to grips with my battleline. Empire soldiers aren't the toughest in the Old World, but they're relatively cheap, and in big units, well led, can usually hold their own against smaller numbers of harder troops. Meanwhile, Golgfag's boys would attempt to work round the right and 'roll up' the greenskins from the flank. The unit that caused me most consternation was Owen's Boarboyz (containing his general and doubtless some scary magic items). While I hoped that my Halberdiers could stand up to his Goblins and Orc Boyz, there was not much in my army that could possibly stand up to this monstrously hard unit. I knew Owen was far too experienced a general to be tempted into attacking my Flagellants (who are immune to Break tests), and even Golgfag might have trouble against them.

My plan was to use my Pistoliers to race up the left flank and get behind Owen's Boarboyz. This would stop him from marching, and if necessary I could charge them in the rear. Though the brave but foolhardy young



The massed ranks of Owen Branham's Orcs & Goblins prepare to take on...



Owen Branham



noblemen would almost certainly come off worse, they would probably kill a few of the elite Boyz, and if they fled (as surely they would), the Boarboyz would be pursuing back towards their own lines! If I could hold them up long enough, I felt confident I could deal with the rest of the green horde, and then turn my whole firepower on the Boar riders.

In the event my plan turned out to be a good one (and Sigmar blessed my dice rolls sufficiently). Normally I take two volley guns because the odds are that one will jam before it does any real damage. My very first roll of the game was a misfire on the first barrel. While this destroyed the gun (and its unfortunate crew), it sent all nine barrels tearing into the Orc hordes. When the smoke cleared, an entire unit of Big 'Uns lay dead! The other volley gun managed to get off a creditable seven barrels before its complex mechanism seized up. This tore the heart out of a regiment of Black Orcs, leaving Owen without his two hardest infantry units. On my right flank, Golgfag's Ogres absorbed the impact of the deadly Goblin Wolf Chariots, and proceeded to smash them into so much firewood. Obviously disappointed by the bland tasting chariots, they set off in pursuit of tastier game. In the end, they comprehensively duffed over a big unit of Goblins, a regiment of Orc Boyz, and when Golgfag ate Owen's Shaman, he secured magical supremacy for the Empire.

The rest of the battle went pretty much to the Empire script. My Pistoliers managed to silence Owen's artillery, before charging the Boarboyz in the rear. Although they failed to kill a single Boarboy, they achieved their aim of distracting the greenskins' most powerful unit. The Orc infantry which reached the Empire line was so depleted that it was easily overwhelmed, and as I'd hoped, I was then able to turn my firepower (twenty Crossbowmen,

ten Handgunners and a Great Cannon) on the Boarboyz. Amazingly, they managed to survive long enough to destroy a unit of Swordsman, but at the end of the sixth turn, only the Orcish general remained alive and not routing. Raising a defiant fist to the grim-faced Empire troops, he was forced to concede the battlefield to the victorious Elector Count.

Well that's how I remember it anyway, and you know what they say; history is written by the victors. It was a great battle, and the two armies did look fantastic arrayed against each other; a classic clash of good and evil.

I think it's time we reversed those roles, and let my Dark Eldar have a crack at Owen's doughty Space Marines.

The mighty Golgfag, mercenary Ogre.

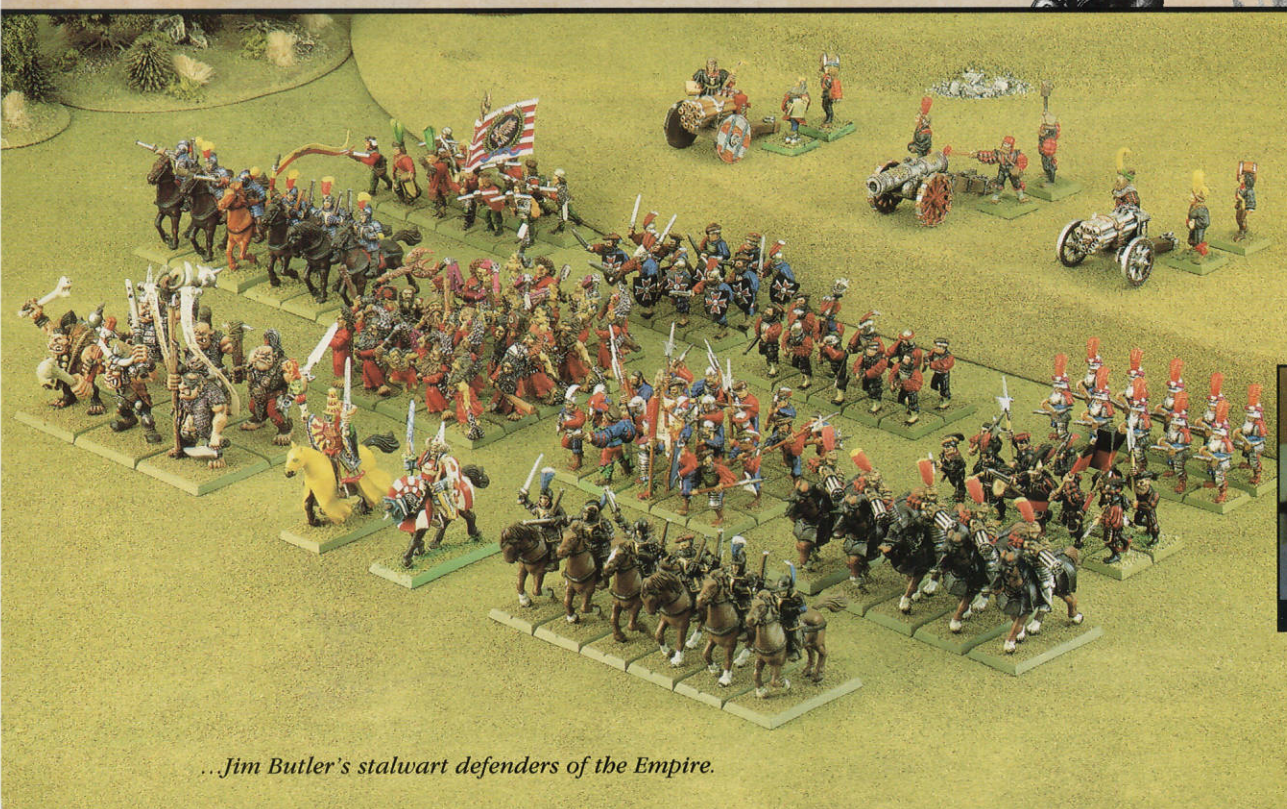

...Jim Butler's stalwart defenders of the Empire.



WARHAMMER®
40,000

SERIOUSLY SPIKY

Following last month's release of the Chaos Rhino with its new Spiky Bitz sprue, comes the awesome Chaos Predator. The Spiky sprue can be seen all over the Studio, being used for various conversions. Matt Hutson's nicked a few to show you...

The possibilities for assembling this splendid, new boxed set are endless – the 'Eavy Metal team has just explored one of these ways. The Spiky Bitz sprue can also be used in conversions throughout your Chaos Space Marine army, and you can now order the sprue individually through Mail Order, so there should be no stopping you.

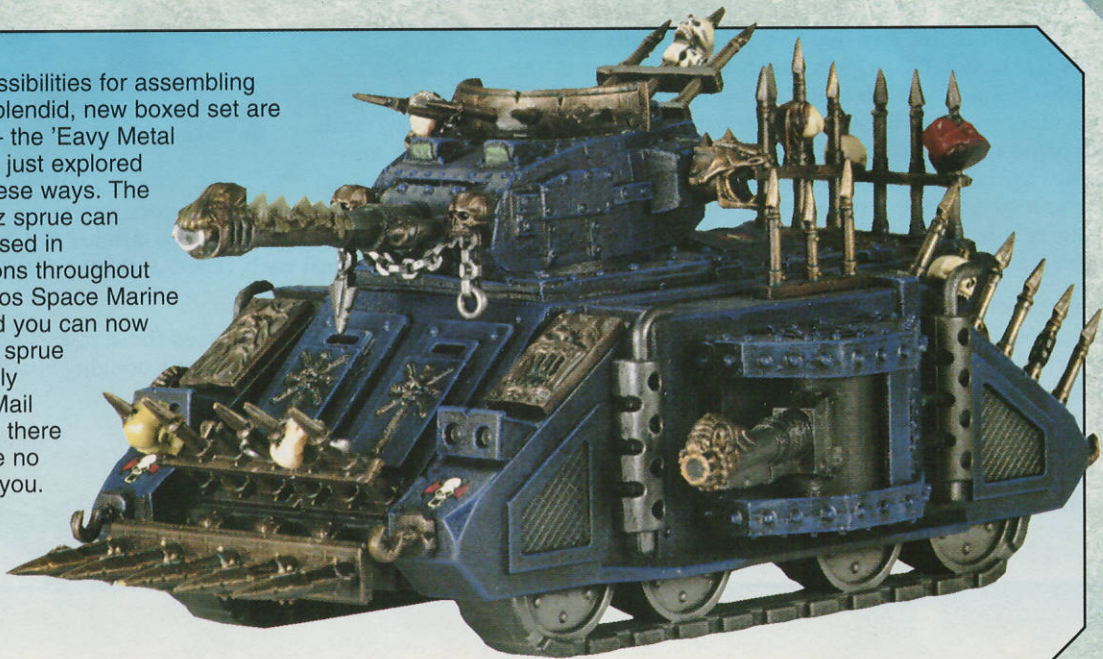

Nick Davis never needs an excuse to start a new modelling project. He has used most of the Spiky sprue to make his Dark Eldar Raider look even more dangerous. All manner of extra skulls and helmets have been added to the end of the chains (it's a complete coincidence that the Space Marine helmet is from the White Scars Chapter).



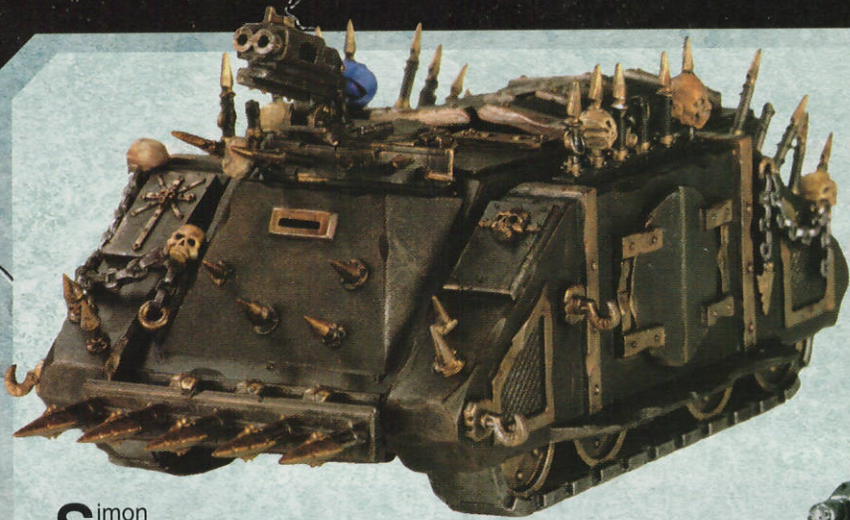

Simon Smith saw the Spiky sprue as great reason in itself to add a Chaos Rhino to his Chaos Space Marine close assault army. Simon has carefully bent the chains so that they hang around the edges of the model. To make the Rhino even more spiky, Simon has also used the spikes from the Chaos Warriors Warhammer Regiment.

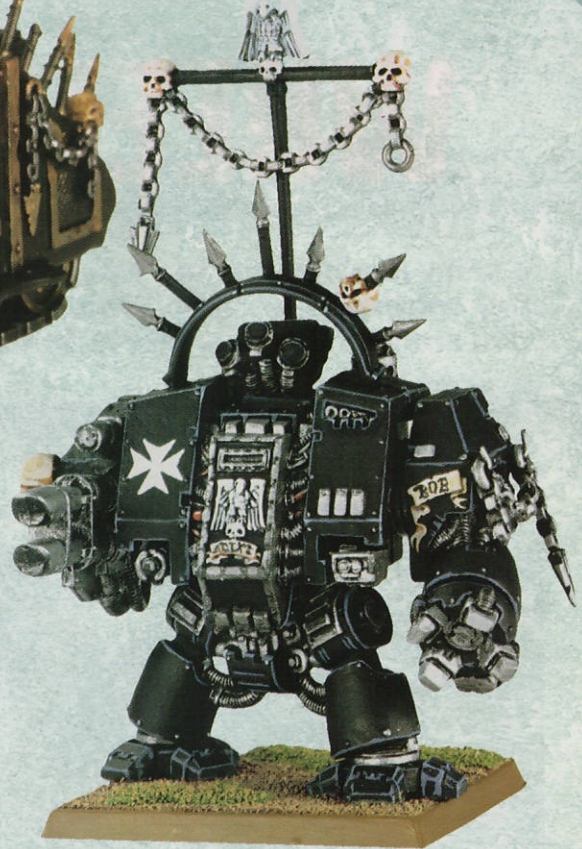

I'm currently collecting a Black Templars army and the Spiky sprue gave me the perfect opportunity to give my Dreadnought a real crusading feel. I see the Black Templars as being crusading knights, bringing the light of the Emperor to all the dark regions of the galaxy. To this end I wanted to give the Dreadnought a spiritual look. I added the spiky piece to the top of the model as I thought this would make a good halo. I added the chains so that the Dreadnought can display the bones of the vanquished. I intend to add trophies from different enemies as I defeat them.

Simon Shuker has converted this Imperial Titan into a Chaos Titan, with the addition of just a few pieces from the Spiky Bitz sprue. If you remove any evidence of scale, like the skulls and other details, then accessories can easily be used in games with different scale miniatures. This also applies the other way around, with Epic Titan/tank weapons used in 40K conversions.



Mark Bedford's Chaos Predator shows that the possibilities for assembling the kit are endless.

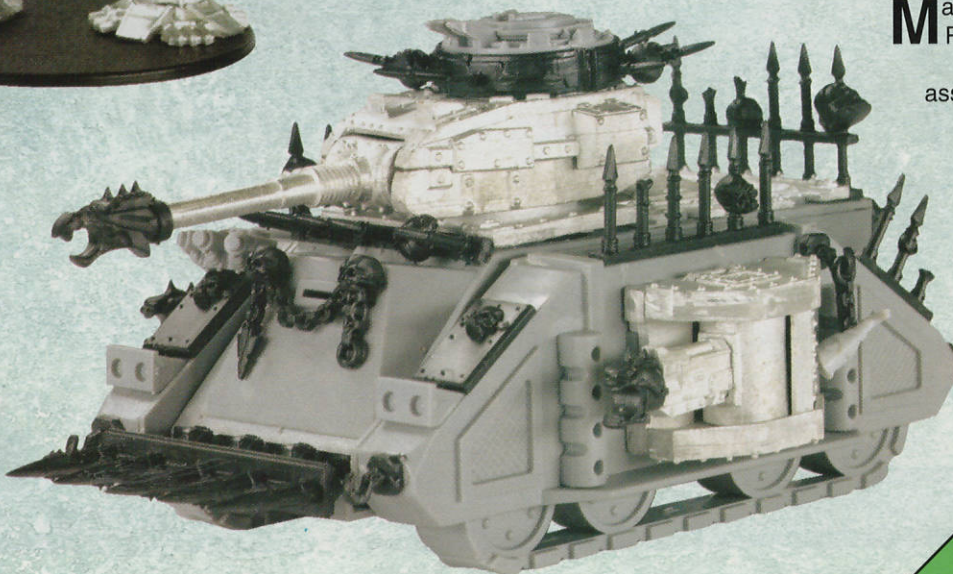

Check out Mail Order to find out how to get your hands on the new Chaos Spiky Bitz sprue.

WHEELS OF STEEL

To show just how the new Chaos Rhino and Predator affect Chaos Space Marine army selection and tactics, Chaos Lord Matthew Hutson has put together a 2,000 point army and tells us how it works...



Emerging from the jungle, a Chaos Predator opens fire.

The Night Lords Legion only fights for the pleasure of battle and the material gain it leads to. This image fits in well with a fast attack army that strikes hard and fast. The fact that they all come from a single Legion will give the army a very uniformed appearance, more reminiscent of a loyal Space Marine Chapter, and will look good on the table top.

The army I have chosen is extremely mobile and is designed to represent a raiding force (as befits the terror raids of a Night Lords army), and it makes good use of the new Chaos Rhino and Chaos Predator models.

The main assault force is comprised of the Chaos Lord and retinue, Terminators, bikers and Raptors. The Raptors fit in well with the feel of the army as they are totally selfish and are not at all concerned with any of the fickle Chaos gods, just like the Night Lords themselves.



Making good use of their Rhino's transport capability, Chaos Space Marines join bikers and a Predator as they break the Imperial Guard line.

'The Ravagers' 2,000 point Night Lords Chaos Space Marine army

Unit	WS	BS	S	T	W	I	A	Ld	Save	Notes	Points
J'dar Fingaen, Exalted Champion	5	5	4	4	3	5	(4)	10	3+	Mark of Chaos Undivided, frag and krak grenades, plasma pistol, master-crafted power axe.	108
Retinuc 8 Veterans	4	4	4	4	1	4	(2)	9	3+	Frag and krak grenades, close combat weapons, bolt pistols, Standard Bearer.	204
Riard W'trii, Aspiring Champion	4	4	4	4	1	4	(3)	10	3+	Frag and krak grenades, close combat weapon, bolt pistol.	50
Rhino										Storm bolter.	50
6 Terminators	4	4	4	4	1	4	2	10	2+	1 combi-melta, 1 combi-flamer, 2 power fists, 1 heavy flamer.	246
6 Veterans	4	4	4	4	1	4	1	9	3+	Bolters, 1 heavy bolter, 1 lascannon.	153
9 Chaos Marines Kal V'rdaran, Aspiring Champion	4	4	4	4	1	4	1	9	3+	Bolters, frag and krak grenades, 1 plasma gun.	201
Rhino	4	4	4	4	1	4	(3)	10	3+	Frag and krak grenades, combat weapon, bolt pistol. Storm bolter.	50
9 Chaos Marines V'harn E'tetz, Aspiring Champion	4	4	4	4	1	4	1	9	3+	Bolters, 1 flamer.	168
Rhino	4	4	4	4	1	4	(3)	10	3+	Frag and krak grenades, combat weapon, bolt pistol. Storm bolter.	50
4 Bikers Dalv Hintar, Aspiring Champion	4	4	4	5	1	4	2	9	3+	Frag and krak grenades, combat weapons.	252
4 Chaos Raptors Killion Salk, Aspiring Champion	4	4	4	4	1	4	(2)	9	3+	Frag and krak grenades, power fist, bolt pistol.	208
Rhino	4	4	4	4	1	4	(3)	10	3+	1 flamer. Power sword, bolt pistol.	50
Chaos Predator										Autocannon, 2 lascannons, combi-bolter.	160
Chaos Predator										Autocannon, 2 lascannons.	150

The heavy support of the army is supplied by the Predators, so they will need to be carefully protected. The bikers and Raptors are ideal for this task as their high speed enables them to engage and tie up the enemy's heavy weapons while the Predators concentrate on killing troops and fast attackers. The Veterans can fulfil both of these roles – either operating exactly like the Predators or using their Infiltration skill to take up a good firing position and eliminate threats to the Predators.

I have given all the normal Chaos Space Marine squads a Chaos Rhino. This increases their flexibility even more, allowing them to be transported into good tactical positions and then be supported by the Rhinos' storm bolters.

Mobilising your Chaos army will not only give your opponent a new headache but provide new tactical challenges for you.



Perched in the ruins, the Raptors prepare to attack.

BATTLEFLEET GOTHIC™

HUNTER, PREY The Raid on Vedyaria Outpost

A Battlefleet Gothic Battle Report
by John Carter, Che Webster and Andy Chambers.

The elegant and deadly ships of the Eldar are available for Battlefleet Gothic this month, so we thought we'd give them a run-out for a game. Playing the swift and lethal forces of the Eldar is the equally swift and lethal John Carter, and doing his duty for the Emperor is Che Webster.

For this game we've used a scenario which didn't make it into the Battlefleet Gothic book due to lack of space. Hunter, Prey is an attack on a pirate base hidden in the asteroid fields at the edge of a star system. The attackers (Che's Imperial fleet) know roughly where the pirate base is and have a strong force at their disposal, fully double the strength of the pirates, to exterminate it.

The pirates (John's Eldar in this case), although outnumbered, have some of their ships and a few planetary defences

hidden among the asteroids, and the rest of their fleet at their base on a small planetoid (with another small planetoid nearby, just to confuse the attackers about which one is the real objective). The attackers need to destroy as much of the pirate fleet as possible and get some of their ships into low orbit over the pirate base in order to destroy it. The pirates need to delay the attackers while they get their fleet off the planet, and then escape with as many ships as they can before the net closes.

If you're interested in playing this scenario, we've included it at the end of the battle report. It's a fun one but not suitable for competitive play, due to the disparate nature of the forces. Safety warnings aside, lets see what John and Che have to say about picking their fleets.

THE MUSINGS OF ADMIRAL WEBSTER



The thing about Eldar in asteroids is that they will hide, sneak and snivel in the rocks. Then they will pop out, shoot, and then run away again. Another thing is that Imperial weapons crews will find that they

can't get a torpedo or lance to track and lock onto an Eldar ship.

I will share with you two principles of dealing with pesky Eldar ships:

Use batteries – big guns are reliable, other stuff is going to be ineffective.

Have a large quantity of batteries clustered together, and DON'T SPLIT YOUR FLEET!

Having to take half my fleet in Escorts (*a restriction of the scenario, see later – Andy*) meant only one choice: Sword class frigates. I wanted twenty-one of 'em, but looking at the Studio fleets I could only (regretful sigh) muster eighteen Swords. So I had to settle for three Firestorm frigates to make up the numbers. In addition I called in three cruisers to give the force backbone: a Dominator class, for the firepower 12 batteries on each side and the added Nova Cannon should I need to pound a static defence platform (and also 'cause the model looks so cool!); a Dictator class, for close aerial defence against bombers and torpedoes – any Imperial fleet should seriously consider one – and because it is a very respectable cruiser even without launch bays; finally the Overlord class battlecruiser, for the sheer



Admiral Webster's 1st Pirate Suppression Battlegroup.

nastiness factor – many guns, low cost. I placed the very useful Admiral (with his re-roll) on the Dictator and I was ready. I didn't even consider battleships because they are too lumbering and vulnerable to Eldar, and in an asteroid field would be the worst possible situation to stick the Imperium's most valuable asset.

The plan? Go in, tight formation, find the Eldar base, close on it, and kill anything that gets in the way.



Pirate Prince Carter's Corsair Command.

PRINCE CARTER'S PATH OF VICTORY



Ah, at last a battle report, a chance to let loose my superior tactical skills against an unsuspecting opponent. Or not.

I've lost far more games than I've ever won, and having played Che (referred to hereafter as

Admiral Rimmer) at Battlefleet before, I know he's one tough player to beat. My one advantage in this battle would be using the Eldar fleet, my favourite. The Eldar are extremely fast, hideously well gunned and look great. Unfortunately their hulls are made of bacofoil, so they require careful handling.

Che knew he'd be facing Eldar, so I expected to face some impressive firepower in the Imperial fleet. To combat this I planned to use my speed and mobility to keep his fleet at a distance, and wear them down, using ordnance to split them up, so that I could get into pulsar range (30 cm) without facing a wall of concentrated fire.

I chose an Eclipse class cruiser as the main backbone of my force, to churn out attack craft in huge numbers (hopefully). I've used an Eclipse before against Che, and a huge wing of Eagle bombers managed to gut an Imperial battleship. Along with massed torpedo volleys, these should force Che to break up his fleet. Then I can pick off the stragglers with the pulsars of my Hemlocks and Hellebores (OK it's not much of a plan, but I am outnumbered). In addition, I get mines and the standard torpedoes of an orbital platform to help avoid the one nightmare I could face – an Imperial fleet in tight formation, presenting enough firepower to steamroller any attack I can make!

DEPLOYMENT



BATTLEFLEET GOTHIC

INTO THE BREACH

TURN 1

Che's fleet began its sweep of the asteroid field in a dense, mutually supporting phalanx. The great mass of frigates arrayed themselves in a protective ring around the lumbering cruisers and battlecruisers as they moved forward. The first wave of frigates picked up unusual energy traces from behind the closest asteroid field. These quickly resolved themselves as a squadron of Hemlock class destroyers on an attack vector. Admiral Webster gamely offered them a chance to come quietly, but his only reply was two Sword class frigates from his vanguard blown apart by Eldar pulsars. The Hemlocks promptly ran for cover to avoid the righteous retribution the rest of the Imperial fleet was preparing for them.

While the Hemlocks made their attack, another energy trace was confirmed as an Eldar Eclipse class cruiser, which slipped away from the approaching Imperials, launching two squadrons of Darkstar fighters and two of Eagle bombers in its wake.

TURN 2

Che responded to the incoming Eldar attack craft by launching four squadrons of Fury fighters from his Dictator class cruiser to intercept. Two squadrons of Swords were despatched to pursue the escaping Hemlocks and caught them in a deadly crossfire. Despite bracing for impact the Hemlocks lost three out of four ships, and John ran the survivor into cover amongst the asteroids. Although this plucky destroyer emerged several times to try sneak attacks, it proved little more than an irritation to the Imperials.

In the vanguard of the fleet, the massed batteries of Sword frigates destroyed one of the approaching Darkstar squadrons, but the Imperial fighters found themselves badly out-matched by their opponents and lost a squadron for no loss to the Eldar. Things got considerably worse when a second wave of Eldar attack craft arrived from the Eclipse, with two more Imperial fighter squadrons destroyed for no loss. Even worse, two squadrons of Eagle bombers broke through and destroyed one of the leading frigates. Despite the casualties, Che could draw some solace from the fact that John had rolled a double while reloading the launch bays of the Eclipse cruiser, meaning that it had exhausted its supply of attack craft for the rest of the battle.

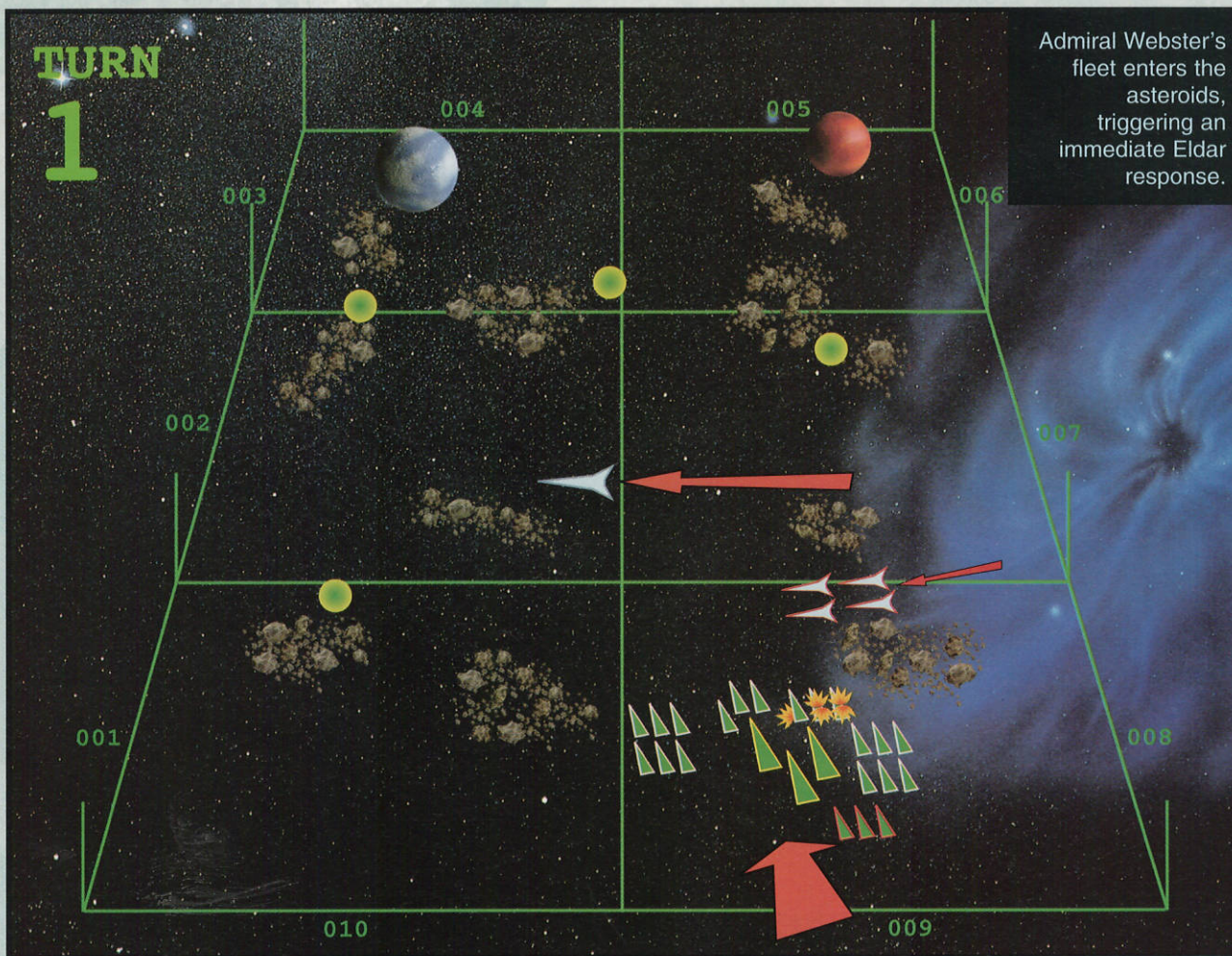

TURN 2

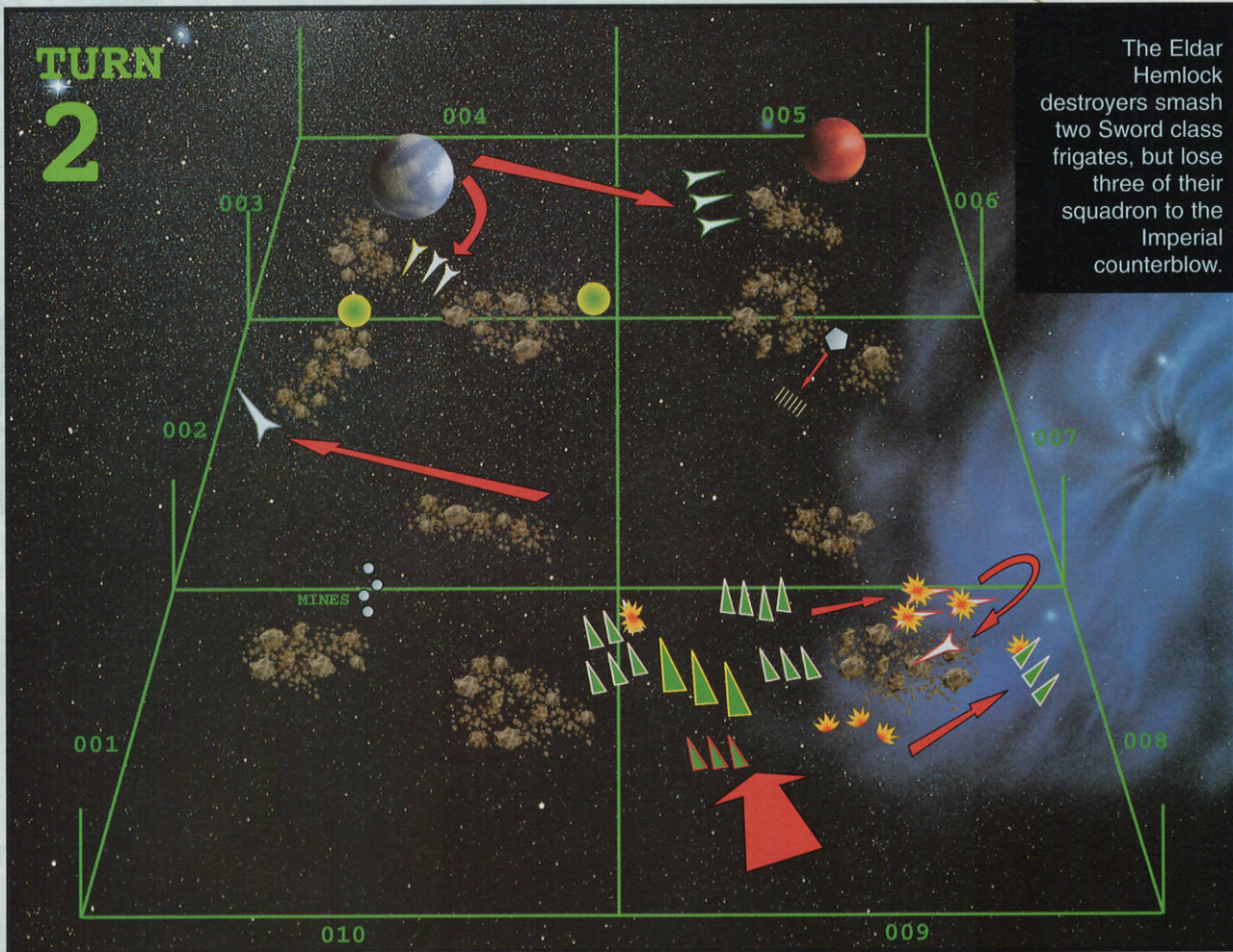

The Eldar Hemlock destroyers smash two Sword class frigates, but lose three of their squadron to the Imperial counterblow.



"Surrender now, Eldar scum!"
Admiral Webster at the Vedyaria Belt.

John activated some of his hidden orbital defences to add to the confusion – a previously undetected defence platform unleashed a salvo of torpedoes towards the centre of the oncoming Imperial fleet and an orbital mine closed in from the opposite side. Under cover of these John successfully scrambled his remaining ships from their planetoid base – one squadron of Nightshade destroyers and another of Hellebore and Aconite frigates. These slid away into cover behind nearby asteroid fields.

TURN 3

The amount of incoming ordnance was getting Che worried by this time. He attempted to reload ordnance aboard his Dictator class cruiser to launch more fighters, but failed the command check. The Swords advanced to protect the cruisers again, and their bright web of laser fire destroyed the torpedo salvo launched by the defence platform. However, a critical gap was opening in the left flank of the Imperial escort screen and the last three squadrons of Eagle bombers launched by the elusive Eldar cruiser were heading straight for it...

The defence platform reloaded and launched another salvo of torpedoes, but this time it was joined by both the Nightshades and the Hellebores gliding

BATTLEFLEET GOTHIC

TURN
3

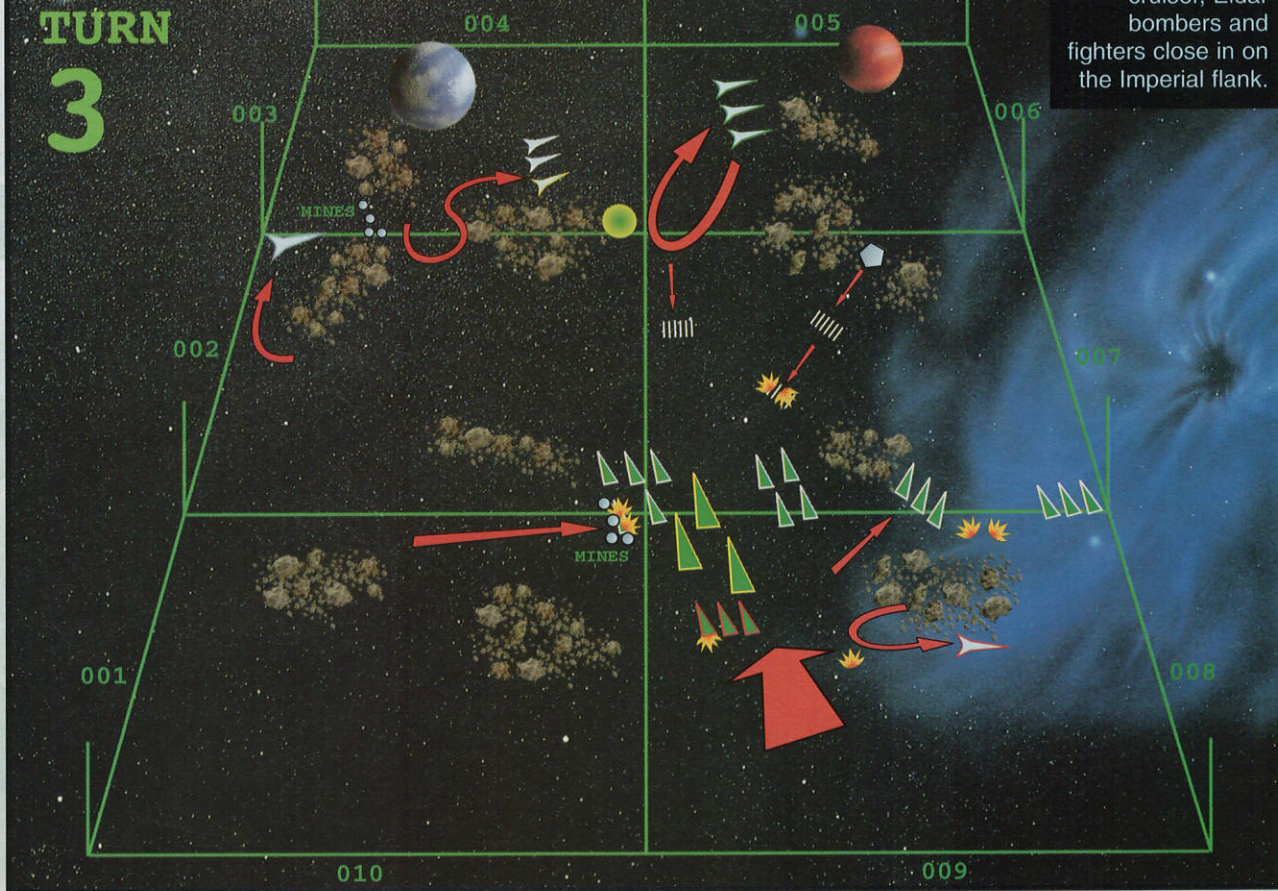

out from the asteroid fields to launch their own salvos of deadly Eldar torpedoes. John also revealed another orbital mine, which started to home in on the Imperial ships.

The three squadrons of Eagle bombers made their attack run on Che's Dominator class cruiser. One squadron was scattered by turret fire despite the protection of their holofields, the others

pressed home their attack... with a miserable lack of success (John rolling a 1 and a 2 for their number of attacks – insufficient even to get past the Dominator's turrets). But wait! Eldar bombers get to re-roll their dice for attacks. John re-rolled and scored... 1 and 2 again. The last Eldar bombers were duly removed to muffled squeaks of fury as John examined his dice to make sure that Che hadn't tampered with them.

THE ELDAR STRIKE BACK

TURN 4

Although the risk of Eldar bombers was at an end, the Imperials still had multiple torpedo salvos incoming. Che opened up his formation and successfully launched two fighter and two bomber squadrons from his Dictator class cruiser. The leading Swords were now in range of the defence platform and fired at it with their weapon batteries, but only succeeded in knocking down its shields. Fortunately the massed weapon batteries of the Imperial cruisers and their escorts enjoyed more success and brought down two of the incoming torpedo salvos. The Dictator's fighters intercepted the third plus a squadron of Eldar Darkstar fighters. The orbital mines, however, proved too tricky a target and continued their approach.

Despite the ferocious Imperial defensive fire, the Eldar attacks continued. The massive detonation of an orbital mine spelled doom for one of the leading Swords. Both the Hellebores and the



Imperial ships surround the stranded fragile Eldar Hemlocks.

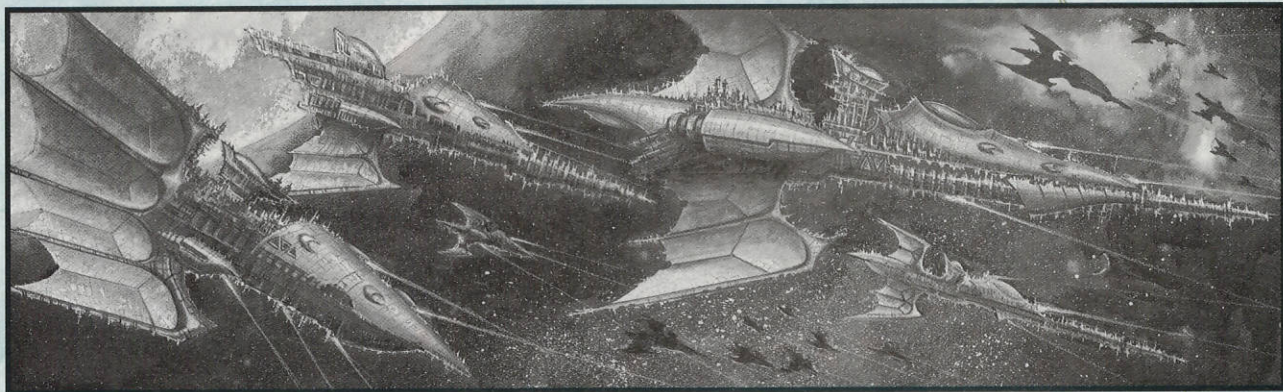

Nightshades reloaded their torpedoes and launched further salvos towards the scattered Imperials. Their payloads delivered, the Eldar frigates and destroyers slipped away behind the asteroid fields again. The final surviving squadron of Eldar Darkstar fighters screamed in to intercept one of the Imperial bomber squadrons.

TURN 5

He tried to pull his fleet back together, turning the Dominator to dodge another torpedo salvo and nestling his escorts closer to their charges, as they started to advance once more. He despatched one squadron of Sword frigates to pursue John's Eclipse cruiser and successfully

launched yet another wave of bombers and fighters from his Dictator. The Imperial gunners performed their tasks admirably – two squadrons of Swords destroying the nearby defence platform, while the cruisers and their escorts eliminated a salvo of torpedoes and the last orbital mine. The Eclipse was hit by the Swords pursuing it and the last squadron of Eldar fighters was finally scattered by fighters from the Dictator. The noose seemed to be tightening around the remaining Eldar – did they still have the strength to fight back?

In response John opted for some bold (some might say rash) tactics. The Hellebores turned and surged through an asteroid field to attack the Swords assailing the Eclipse. Though they had a

few scary moments, the whole squadron emerged intact. The Eclipse also came about to avenge itself on its pursuers.

The Nightshades reloaded their torpedoes and swept around the asteroids to launch a salvo at the Swords which had destroyed the defence platform. Despite an impressive showing from the Swords' turrets, the Nightshades' torpedoes ripped through their squadron, destroying two ships and slicing on into the Dictator behind, scoring one point of damage on it.

The Hellebore and Eclipse's attack on the other Swords fared less well due to bad luck on John's part. Two frigates were destroyed by pulsar fire but the Hellebores' torpedo strike on the

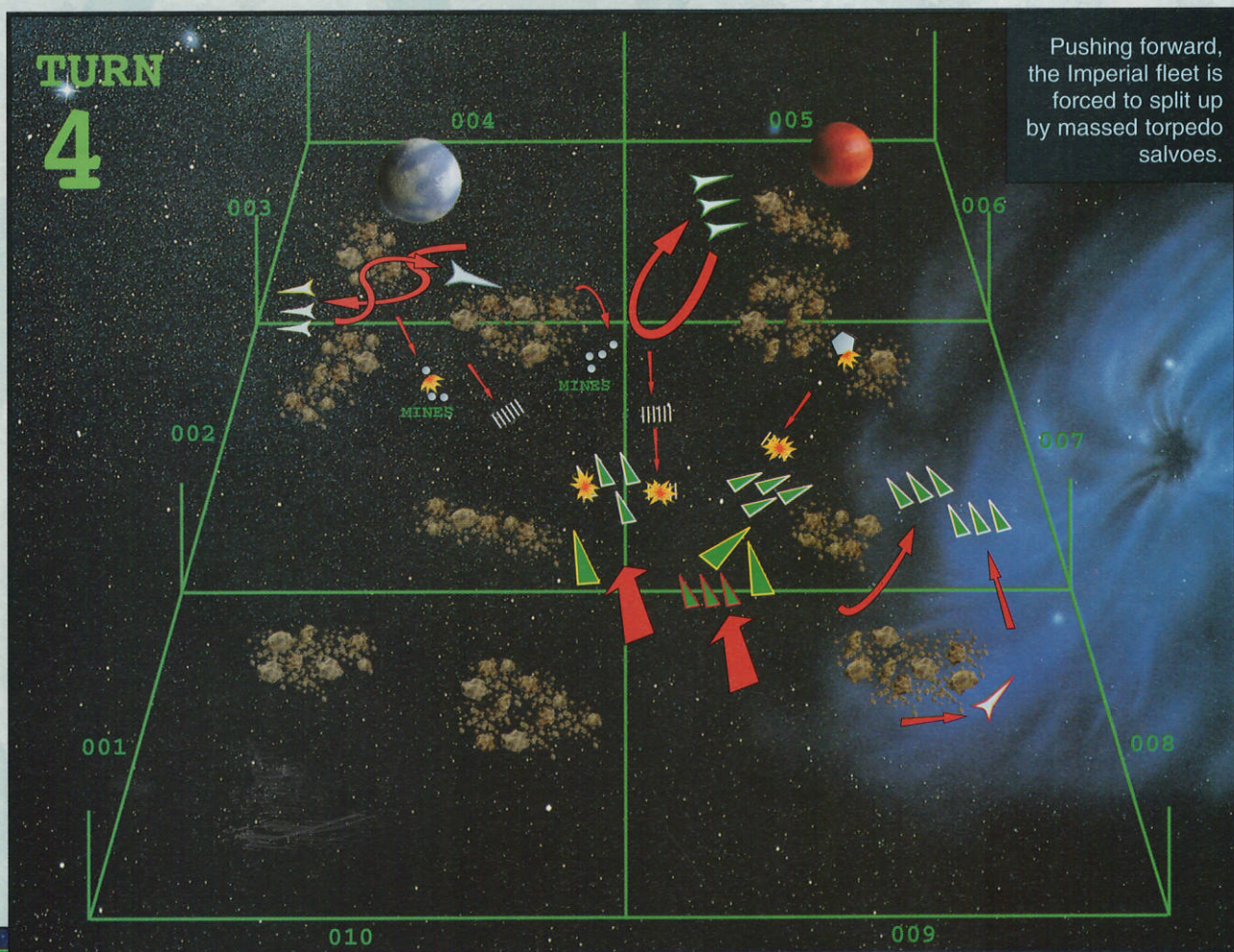

BATTLEFLEET GOTHIC

TURN
5

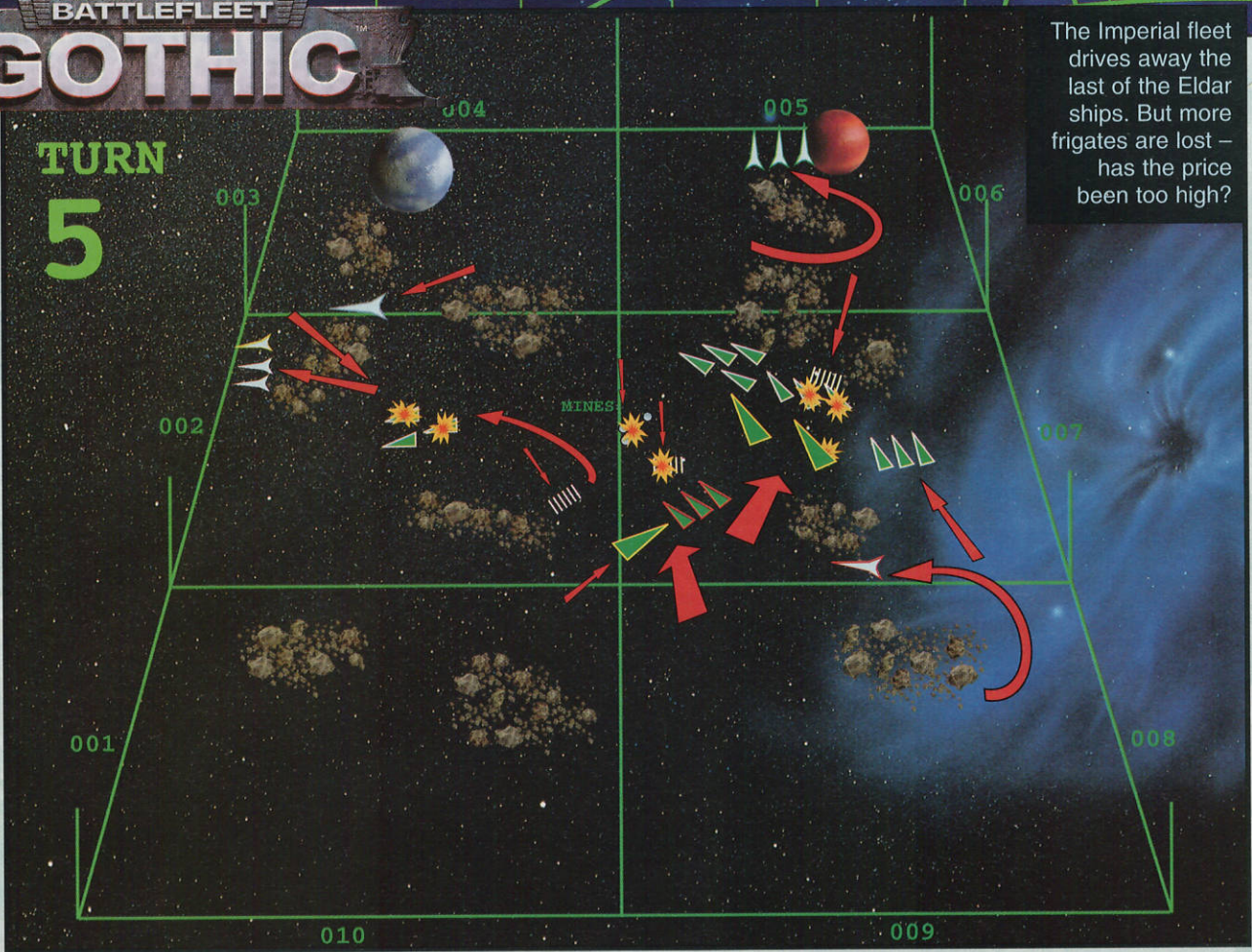

The Imperial fleet drives away the last of the Eldar ships. But more frigates are lost – has the price been too high?

survivor was blocked by the resulting blast markers. Worse still, a squadron of Imperial bombers made a successful strike on the Eclipse, crippling it and smashing the bridge of the fragile vessel. As one the Eldar ships turned and fled beyond the asteroids again, the Hellebores and Nightshades both moving through the fields without a scratch – Eldar Leadership is certainly not to be underestimated!

TURN 6

He pushed on into the breach left by the scattering Eldar forces, launching another wave of fighters and bombers from the Dictator to lead his advance. His squadron of Firestorm frigates and the surviving Sword pursued the Eclipse and its Hellebore escorts relentlessly, and were rewarded by the destruction of a Hellebore and punishing the Eclipse even further.

With a deep sigh John reloaded the Nightshades one more time, and launched a salvo of torpedoes at the pursuing Swords. One Sword was utterly devastated by the torpedoes (being hit by five out of six of them!) but the Hellebores' last snap at the surviving Sword was paltry and barely knocked down its shields. Deciding that he had done all the damage he could expect to achieve, John turned his ships away and disengaged by leaving the tabletop.

RESULTS	CRUISERS	ESCORTS	DEFENCES	VICTORY POINTS
IMPERIAL	0	10 DESTROYED		292.5
ELDAR	1 DISENGAGED (CRIPPLED)	4 DESTROYED	1 DESTROYED	405

Introspections upon the Path of Victory

Victory! The human savages have once again been shown that they are too primitive to claim dominion over the stars!

Well, actually my base is a smouldering ruin, my treasured flagship is limping its

way to the bonesingers, and I've just been kicked out of a star system, but you can't have everything – I was lucky to get any kind of victory at all.

The battle was almost lost at the start, when I forgot all my plans and tactics and threw my forces at the enemy, for which I was severely punished. Fortunately this sobering lesson (aided by the wise Mr Chambers waving a scrap of paper in my



Hellebores and the Eclipse avenge themselves on the pursuing Swords.

face, on which was written 'hit and run') made it obvious that only sticking to the plan would work. Long range ordnance was the order of the day. Diving into close range and hoping my speed would get me out again was a recipe for disaster, I couldn't get close to the massed Imperial fleet without risking annihilation. But after the fleet split in response to massed torpedo volleys (which were all shot down), it was a different story, the flanking escorts became vulnerable.

If Che had followed the old adage "Full ahead and damn the torpedoes", I'd have had to have launched a last desperate attack to stop them reaching the planet. As it was, with half of the Imperial escort force destroyed, I could evacuate the base and exit the system with the remains of my fleet (and pride), to fight again another day.

Now if I could just manage to roll a few 4s when shooting pulsars, I'd be happy.

The testimony of Admiral Webster

Defeat. Hmm. A technicality surely. Where is that Eldar base now (evil grin)?

Massed batteries against Eldar work. I lost because I broke my second principle; I allowed the torpedo runs to break up my fleet. It was an easy choice – lose formation or lose a big ship. I think the real reason the Imperium lost is revealed in the old naval saying: "You may as well try to catch starlight as bring the Eldar to battle."

For me the battle rested on trying to catch the Eclipse cruiser and destroy it, and then get at least one of my cruisers

into planetary low orbit. In the quick practice game that John and I played, I managed to do just this, and it took 7 turns. But this time he disengaged and denied me the vital victory points I needed – well done John!

I learnt that I was theoretically correct, but that theory needs to be carried out with ruthlessness and confidence. You should not underestimate the damage the Eldar can do to any fleet they engage, yet in this scenario you have to go hell for leather into their territory and swallow some damage. For goodness sake, why was I so careful with twenty-four ships and a superiority of two to one?

Truth be told: I fear those Eldar... and rightly so... trust me on this...

SCENARIO ELEVEN: HUNTER, PREY

The enemy has established a secret base in a strategically important star system. Enemy raiders have been traced back to an area of asteroid fields at the fringes of the system and a battle group has been formed to hunt them down and destroy the base. The strength and composition of the raiding forces is unknown, so the hunters must be cautious in case they become prey. Note that this scenario is eminently suitable for use in campaigns.

FORCES

Choose a points value for the hunting fleet, the raiders choose a fleet with a value of up to 50% of the hunters' fleet.

The hunting force is chosen from the fleet list with some extra restrictions because forces have to be widely spread to find the raiders, and convoys still have to be protected while the hunt goes on. This means at least half of the hunters' points must be spent on escort ships and a maximum of one battleship may be chosen.

The raiders' forces are chosen from the appropriate fleet list, again at least half of the raiders' points must be spent on escort ships, and no battleships may be included. Once the raider has chosen his forces, he splits them into two groups and numbers them 1 and 2. One of these groups is in dock at the base and the other is out guarding the base or quietly slipping back to it after a raid. In addition the raiders may spend an extra D6x10 points (on top of their basic 50% of the hunters' points total) on orbital defences. These do not have to be placed in either of the two raider forces, but are deployed separately as noted below.

BATTLEZONE

Establish the direction of the sun and place D3 asteroid fields in each quarter of the table. Place two small planets, one in each of the table quarters furthest from the sunward edge. The planets must be placed more than 30cm from any table edge.

SET UP

The raiding player sets up first. Roll a D6 to determine which force is on guard; 1-3 = force 1, 4-6 = force 2. Place a counter face-down on the table for each cruiser and escort squadron in this guarding force. Counters must be placed at least 30cm apart and may not be placed within 45cm of the sunward table edge. If all of the counters cannot fit onto the table, start to double them up by placing an extra counter on top of each one already placed. The raiders' other force is docked in low orbit at one of the two planetoids – secretly note down which one. The planetoid where the raiders are docked is the location of the secret base.

The raiders' orbital defences may be placed anywhere on the table which is not within 45cm of the sunward table edge. Place a face-down counter to represent each of the raiders' defences.

The hunting forces are deployed within 15cm of the sunward table edge.

FIRST TURN

The hunting player gets the first turn.

SPECIAL RULES

The raiders' face-down counters are activated by a hunting vessel moving within 30cm of them. Turn the activated counter face up as soon as the vessel moves within range and then complete its movement. Once the hunting player's movement phase is finished, deploy the raider forces for any activated counters as noted below.

The raider player may voluntarily activate one counter at the start of his own movement phase, to represent his forces detecting the approaching hunters. If any of the hunting player's ships are using special orders, the attacking player may voluntarily activate up to two counters.

Squadrons: Place one ship from the squadron on top of the counter. The rest of the squadron is placed in formation with the first ship, no closer to the enemy than the first ship placed. The ships may be deployed facing in any direction but all the ships in the squadron must be pointing in the same direction.

Orbital defences, cruisers or battlecruisers: Place the orbital defence unit, cruiser or battlecruiser on top of the counter, facing in whichever direction the raider player chooses.

The vessels docked at the planet may not move out of low orbit until they pass a Leadership test at the beginning of their turn. Note that this is not a command check so you can continue testing for each ship or squadron even if you fail a roll. Units moving out of low orbit may not be placed on special orders in the same turn.

GAME LENGTH

The battle continues for ten turns or until one side is destroyed and/or disengages.

VICTORY CONDITIONS

The hunters and raiders score standard victory points for destroying or crippling ships, but the hunter receives no victory points for raider ships which disengage. Instead the hunter scores bonus vps equal to the points value of any of his ships which are in low orbit over the raiders' planetoid at the end of the game (they can quickly land and capture the raider's base). The raiding player scores bonus vps equal to 10% of the points value of any ships which disengage by the end of the game.

BATTLEFLEET GOTHIC™

NEW CONTACTS

By Fleet Admiral Nick Davis, with a little help from Chaos Warmaster Rich Baker.

With the war in the Gothic Sector intensifying every day, warships become a valuable asset. Further reinforcements break through to the Gothic Sector this month. Imperial Admirals can add the popular Dauntless class light cruiser, the Emperor class battleship and Firestorm class escort frigates to his fleet. Chaos Warmasters also receive reinforcements, with the devastating Despoiler class battleship and the Iconoclast destroyer escort ships.

IMPERIAL EMPEROR CLASS BATTLESHIP

The Emperor class battleship is amongst the oldest of the warships in the Gothic Sector. It is a slow and ponderous vessel even compared to other battleships, but it is capable of launching huge, devastating waves of attack craft. Emperor class are considered to be lucky ships. During the Gothic War, the *Legatus Stygies* survived a suicidal ramming attack in the Battle of Callawell, escaped destruction during the disastrous Purgation of Ulthranx and destroyed the Chaos battleship *Black Pain* at Arriva.

Nick's tips: I use the Emperor primarily as a fleet support vessel. With its long-ranged firepower mainly dorsal and prow-mounted, it can keep back from a battle and still engage the enemy. Its main contribution to an engagement is the armada of attack craft it can launch. In one turn it can launch enough bombers to cripple a capital ship and in turn has enough turrets to stop all but the largest attack craft wing from damaging it. Remember the Emperor is very slow and turns even slower, so when engaging the enemy at close range, try to keep a couple of escorts back to guard its stern against enemy destroyers.

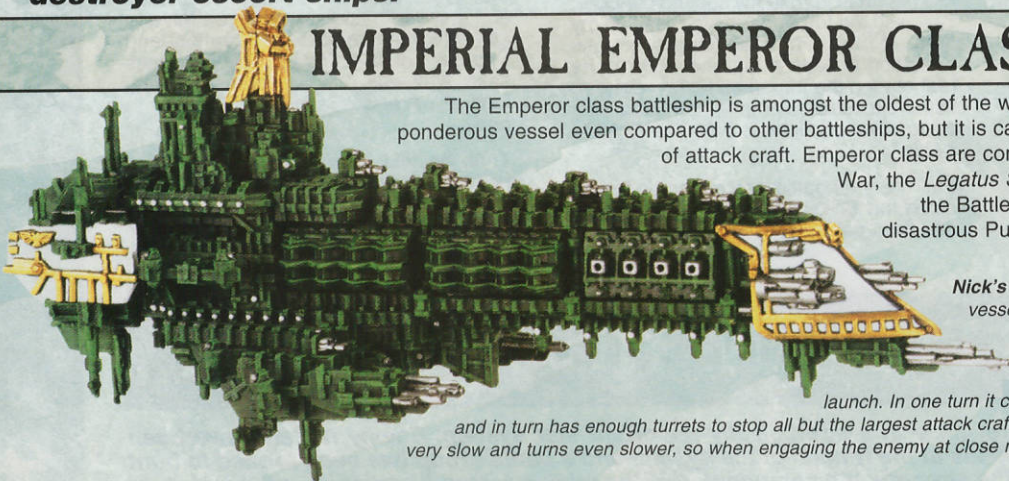

IMPERIAL FIRESTORM CLASS FRIGATE

Firestorm frigates are built around a Sword class hull, but with the central laser cores directing power towards the huge lance mounted on the prow. They were created in an effort to combine the speed of an escort ship with the power of a lance armament.

Nick's tips: The Firestorm's strength is in its front lance. Mass together a large squadron of three or four and they become as dangerous as a capital ship. Use their speed and manoeuvrability to get around the sides of the enemy's capital ships and then start sniping at their sterns.



IMPERIAL DAUNTLESS CLASS LIGHT CRUISER

The Dauntless has always been a feature of Imperial fleets throughout the Imperium. They are a popular class, as fast and manoeuvrable as a frigate but with a ferocious frontal lance armament.

Nick's tips: Remember the Dauntless is a light cruiser and is not capable of repelling large amounts of firepower. Use its speed (it gets an extra D6 on All Ahead Full orders) to chase down enemy escorts or to get round the back of enemy cruisers. Its main lance armament is devastating – time your shots to hit an enemy ship after its shields have gone down.



IMPERIAL ATTACK CRAFT

Attack craft, although tiny compared even to a destroyer, should not be ignored. They have a vital role to play in any engagement and have the potential to be more deadly than a battleship.

Nick's tips: I never go into battle without an attack craft carrier – these ships play a vital part in a naval engagement. Keep your fighters close to your capital ships; this makes them more flexible than sending them out on long-ranged intercepts. When using your bombers, form them into huge wings (minimum of four squadrons) before you send them after the enemy's capital ships, and if possible assign fighters to escort them (they'll take the turret hits first). The hit and run attacks of assault boats can cripple an attacking ship's weapon systems, leaving it unable to reply to your guns. Have your attack craft carriers close with the enemy before launching them (assault boats are just as vulnerable to fighters as bombers, and you will need to form two waves to get past the turrets of a capital ship, so you probably won't be able to launch fighters to escort them).



FURY INTERCEPTORS



STARHAWK BOMBERS



SHARK ASSAULT BOATS

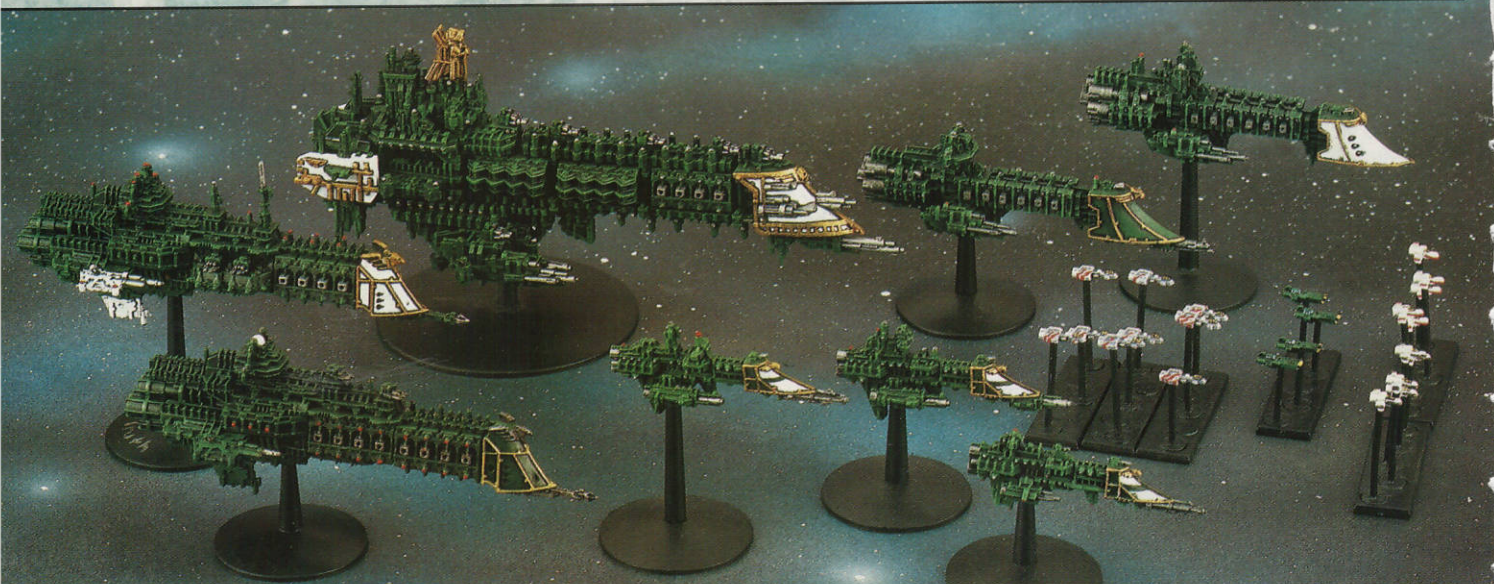

CHAOS DESPOILER CLASS BATTLESHIP

The Despoiler class battleship was developed out of a belief that attack craft would be the ultimate weapons in space warfare. However the true battleship was not outmoded by attack craft, so only three Despoilers were ever built. The first Despoiler turned traitor 250 years after its initial construction and it soon disappeared. It appeared 30 years later to destroy an unprotected convoy in the Banardi Sector, then it vanished again. The two remaining ships turned traitor in quick succession after firing on friendly vessels and escaping into the warp.

Rich's tips: The Despoiler is a powerful vessel – in some ways it's more powerful than its counterpart, the Emperor. It is an attack craft carrier and this really adds to its strength. Use the Desolator aggressively; it can close with the enemy, engaging at close range with little fear of being outgunned. After trading fire with the enemy capital ships, it can launch a huge wing of bombers to finish them off. A Despoiler battleship and a Styx class heavy cruiser in the same fleet make a deadly combination, as each can launch alternate wings of fighters and bombers.

Although the Despoiler is faster than its Imperial counterpart, the Emperor, it is just as slow to manoeuvre. So when you close with the enemy, pull back a pair of escorts (Idolators are perfect) to guard its stern against enemy escorts.



CHAOS ICONOCLAST CLASS DESTROYER

The Iconoclast is a common sight in the countless fleets of pirates and raiders that inhabit the Gothic Sector. It carries respectable firepower for its size, and the vessel's design is so simple that it can be produced by any shipyard.

Rich's tips: Iconoclasts are fast ships. Use them in squadrons of four to five and have them escort a Murder or Slaughter class cruiser. When the Chaos cruisers engage the enemy's capital ships, nip the Iconoclasts round the front or back of the enemy, so their combined firepower strength of 12 or 15 will be firing on closing or moving away targets.



CHAOS ATTACK CRAFT



Chaos fleets, like their Imperial enemies, have access to attack craft. They act in much the same manner.

Rich's tips: Form your fighters around your capital ships. This way they can easily intercept incoming torpedo attacks (the Imperial Navy uses torpedoes as a main form of attack).

BLACKSTONE FORTRESS



Above: An activated Blackstone Fortress – the most devastating vessel in the Gothic Sector at the time of the conflict.

Right: A dormant Blackstone Fortress, converted into an Imperial naval base using the cruiser weapon sprue and turrets from Epic tanks (more details on this conversion and other space stations in a future issue of White Dwarf).

The mysterious Blackstone Fortresses were key to the defence of the Gothic Sector. Although almost entirely dormant when discovered by Imperial forces, the Adeptus Mechanicus were able to tap into their power grids. They built defence turrets and opened huge areas over its surface for launch bays. The Imperial Navy thought them to be indestructible, indeed it was a matter of pride amongst the Navy that no Blackstone had ever been taken in battle.

When the invasion of the Gothic Sector took place, Abaddon had found a way to shut down the Blackstones, trapping the crew inside and thus capturing them. The next time a Blackstone appeared it had changed; it moved with a life of its own and possessed a weapon that seem to tap into the warp itself. This could unleash a beam of energy that would bypass shields and tear a ship apart. The Blackstone Fortresses became the most dangerous vessels in the Gothic War.

Nick's tips: An activated Blackstone Fortress is immensely powerful. It is more than able to cripple or destroy a capital ship in one volley from its warp cannon. However it does have one major weakness – no turrets – so it cannot defend itself against attack craft or a torpedo run. Bomber waves and torpedoes are the most effective way to destroy a Blackstone.

Rich's tips: You can protect the Blackstone from bombers by taking an attack craft carrier like a Styx class or even a Despoiler battleship. These ships can unleash huge fighter wings that can intercept the bombers (or torpedoes) before they start their attack runs.

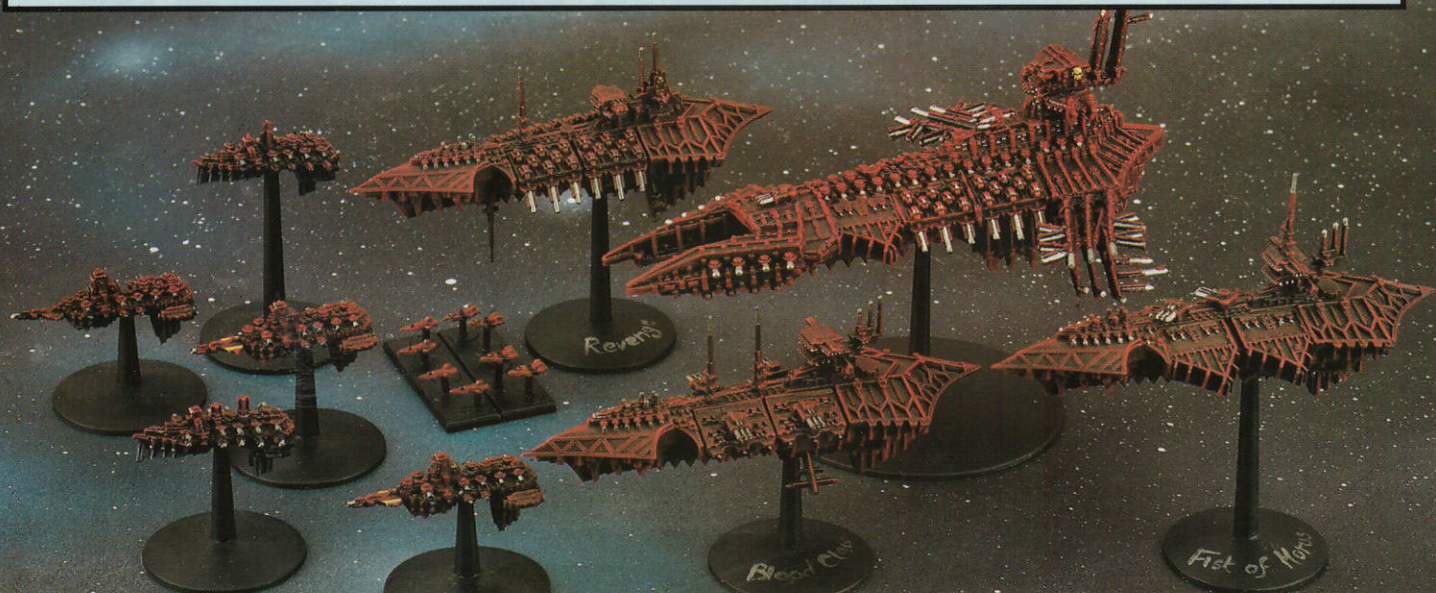
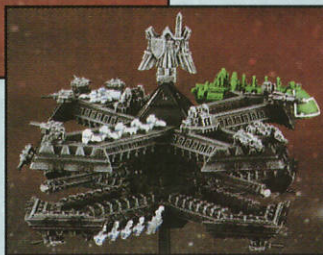



SCRIPT: GORDON RENNIE • ART: MIKE PERKINS • LETTERS: FIONA STEPHENSON



OUTNUMBERED, THE DWARFS DO NOT RETREAT. HERE, IN THE HALLS OF THEIR CLAN HOME, THEY KNOW THE SPIRITS OF THEIR ANCESTORS ARE WATCHING THEM.



TODAY, A DEBT EIGHT CENTURIES IN THE MAKING WILL FINALLY BE PAID.



THE DWARFS OF KAZAD MAKAZ REMEMBER EVERY WRONG DONE TO THEM--



EVERY BATTLE LOST. EVERY OATH BROKEN. EVERY DEATH UNAVENGED--



ALL OF THEM FAITHFULLY LISTED IN THE DAMMAZ KRON, THE CLAN'S SACRED BOOK OF GRUDGES!



TODAY, AT LEAST ONE OF THOSE GRUDGES CAN BE MARKED SETTLED.



WITH THE DEATH OF THEIR WARLORD, THE GOBLINS FLEE IN TERROR--

FIND THEIR LAIRS! CLEANSE OUR CLAN HOME OF THE GROBI FILTH!

EVERY EXPLOSIVE ISSUE. MISS IT AT YOUR PERIL!!

SPECIAL FEATURES • PIN-UPS • EXCLUSIVE READERS' OFFERS • INTERVIEWS WITH ARTISTS & WRITERS • ALL THIS AND MUCH MORE, ONLY IN WARHAMMER MONTHLY



FOLLOWING A SECRET ROUTE PASSED ON TO HIM BY GENERATIONS OF FOREBEARS, THE DWARF LORD DESCENDS INTO THE DEPTHS OF THE STRONGHOLD...



...REACHING THE TOMB CRYPTS OF THE KINGS OF KAZAD MAKAZ, UNDISTURBED THESE LAST EIGHT HUNDRED YEARS!

NOW THERE IS ONLY ONE TASK TO COMPLETE...

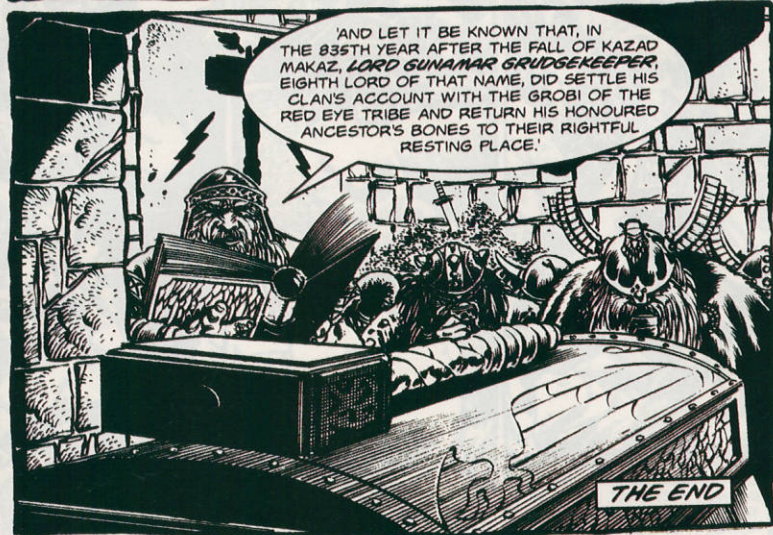

AND LET IT BE KNOWN THAT, IN THE 835TH YEAR AFTER THE FALL OF KAZAD MAKAZ, LORD GUNAMAR GRUDGEKEEPER, EIGHTH LORD OF THAT NAME, DID SETTLE HIS CLAN'S ACCOUNT WITH THE GROBI OF THE RED EYE TRIBE AND RETURN HIS HONOURED ANCESTOR'S BONES TO THEIR RIGHTFUL RESTING PLACE!

THE END

INSIDE: JERICO'S BACK! • LET THE UNDERHIVE BURN!

15

WARHAMMER
MONTHLY

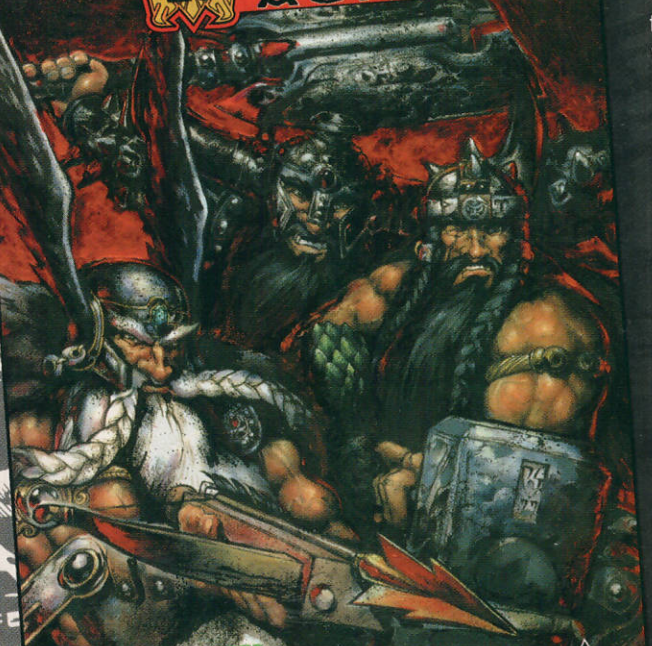

D'YE WANT SOME?

DWARFLORDS

plus KAL JERICO • DARKBLADE • INQUISITOR

DARK, I DIDN'T
OI, WAZZOCKS!!

Get a load of this in yer grubby ear 'ole. If you've enjoyed reading about Dwarf clansmen kicking in a whole heap of gobbo scum then make sure yer don't miss the next awesome episode of Warhammer Monthly.

Every issue of Warhammer Monthly is crammed to bursting with 44 pages of explosive mayhem, featuring awesome stories about all your favourite armies and races, written and drawn by some of the finest comic artists and writers in the business.

This month's issue features the final frenzied episode of Dwarflords. Witness some spectacular battle scenes as our three stout heroes battle through an army of Chaos to save their home, Karak Kadrin. Kal Jerico, Necromunda's finest, returns. This time he must rescue his malodorous sidekick from the clutches of the Redemption. See Malus Darkblade, Dark Elf anti-hero in action, as he assails his own kind to steal the Orb of Truth and Lies from a landlocked Black Ark. Finally, don't miss another episode of intrigue and insidious Chaos plots in the 41st Millennium, with Inquisitor.

WARHAMMER MONTHLY #15

£2.00

ISSUE 15 - OUT MAY

A SECRET WAR DARKNESS FALLS

A Warhammer 40,000 Battle Report
by Graham Davey, Mark Bedford and Iain Compton.

This month's battle report uses Jervis Johnson's special 'Secret War' scenario from earlier this issue. We suggest you read the first two pages of the scenario before proceeding with this battle report, as they give some insight to the background for the battle.

Grand Master Gideon approached one of the Inner Circles' most secret chambers to witness the interrogation. The Night Lords Chaos Space Marine had been caught after a surprise counter-attack by the Dark Angels on one of the Chaos traitor raiding parties. The passageway led deep into the Dark Angels fortress-monastery. Torches mounted on the walls lit the tunnel, and the flickering created an eerie effect on the jagged, rocky walls. Gideon strode through the opening into a circular chamber where a select few members from the Inner Circle stood before Supreme Grand Master Azrael. Though all their faces were concealed by their hoods, he knew each one of them as his equals within the Circle.

The Chamber was enclosed and completely bare except for the circular, transparent armour-glass floor, revealing the interrogation chamber below.

"Welcome brother Gideon," voiced the Supreme Grand Master. "You are to take command of the Ravenwing. We have the Fallen One within our grasp – this may be our greatest moment." He paused and then the silence was broken by a faint screaming, muffled by the thickness of the glass.

Night Lords Champion Vrax lay strapped to the interrogation table, removed from his armour for the first time in millennia. Electropulses surged through his body at regular intervals and the sweat stung his eyes and blurred his vision. He cursed himself for being caught by these children that dared called themselves Space Marines. But Cypher, with Abaddon's blessing (curse them both), had taken command of most of his Night Lords warband. How was he expected to conduct terror raids successfully without the whole of his force?

No doubt he would die on this cold, steel table – the Dark Angels had no reason to keep him alive except to remove information from him. It wouldn't help to withhold it from them as the agony would just be prolonged. Better he get revenge on Cypher for his demise. He just wished they'd get on with it and begin the interrogation. He knew the electropulses were just the start and didn't care to experience the torture he himself had used on his own captives in previous times.

His vision began to clear and he stared upwards. Upon the armour-glass ceiling stood seven white-robed Dark Angels; one occupied the centre of the circle while the others stood around him. Motionless, they all stared down at him through the floor. Suddenly his vision was obscured and focussing his eyes on the new presence, Vrax saw the skull-masked Chaplain leaning over him, holding a twisted blade that glinted in the light from the torches.

"So tell me... WHERE IS CYPHER!"

You've read the introduction to the Secret War scenario? Good. If not then this may be a little confusing, so go back to page 42 and get reading.

After reading the brief for the Dark Angels, Mark chose to protect the innocent (ie: the investigators). Graham meanwhile decided that an immediate attack on the investigators was the best idea. These choices led to the two forces bumping into one another while trying to move into position. The mission played to represent this was Recon. Neither side would be allowed to infiltrate and the investigators would not be used.

The Recon mission entails both players trying to punch through the enemy lines and get as much of their army as possible into the enemy's deployment zone. Units that manage to do this gain bonus victory points at the end of the game (+200 for undamaged vehicles and squads above half strength, and +100 for any others).

With the mission chosen, it was time to take to the battlefield and get on with the game.

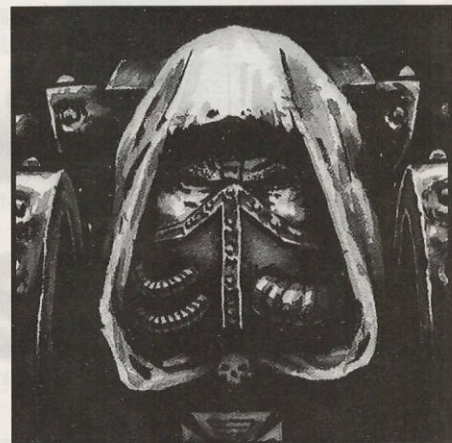



SEARCH FOR THE FALLEN ANGEL



Grand Master Bedford

A few weeks ago Paul Sawyer asked me if I would like to fight a battle report against a Chaos force, using the Games Workshop Dark Angels army. Well who could refuse an offer like that, playing with some exceptionally well-painted models and the chance to rid the galaxy of more vile Chaos scum.

The first thing I had to do was to read the Secret War scenario and the Dark Angels brief. What would my Dark Angels force do? I came up with the conclusion that they would protect the innocent – no more must be tainted by Chaos.

The next dilemma was what force to choose. As I have my own Dark Angels army, I thought I would try fighting with a different style of army. I managed to get a sneaky peek at the Dark Angels Codex and saw that there were

options on using different parts of the Dark Angels army in companies of their own i.e. entire Deathwing or Ravenwing armies.

Ravenwing, that would be my choice – all those bikes and Land Speeders screaming across the battlefield, crushing the enemy in a hail of bolter fire. What better way to protect the innocent than a fast, highly manoeuvrable force that could quickly adapt to changing situations on the battlefield.

The downside to picking an entire Ravenwing force is that you are limited in your choice of weapons and armour. You can't take lascannons, missile launchers or heavy flamers, and no Dreadnoughts. You will also have fewer troops than your opponent, but hopefully you can outmanoeuvre them!

The upside is you can get heavy weapons (multi-meltas) into combat very quickly; ideal for making hit-and-run attacks against Dreadnoughts, Terminators and vehicles. Bikers get an extra +1 to Toughness and Ravenwing drivers/pilots can 'jink' their vehicles, which is useful if they are shot at by heavy weapons that would otherwise destroy them with no save.

The mission proved to be Recon. Two forces trying to get to the opposite side of the battlefield (great – ideal for high speed vehicles!). This would also result in a large firefight in the centre of the table.

I decided to deploy the Land Speeder squad on one side of my army to use in a flank attack. Hopefully they

would speed round the back of Graham's army and gun them down in a hail of assault cannon and heavy bolter-fire. On the other flank of my army I would use a bike squad, also with the aim of getting round behind the Chaos army.

The centre of my force would consist of a second bike squad, an attack bike squad and my HQs. The HQs were set so they could offer assistance to any of my central force, depending on who was taking the brunt of the Chaos attack. Now to war!

Note: If you check the Codex, you may notice that this isn't a strictly legal army – in order to take an all-Ravenwing army, you must take the Master of the Ravenwing special character. However, as there is no figure available yet, and Mark had just completed a conversion of a bike-mounted Ravenwing Master, everyone agreed that he could use this to lead his army.

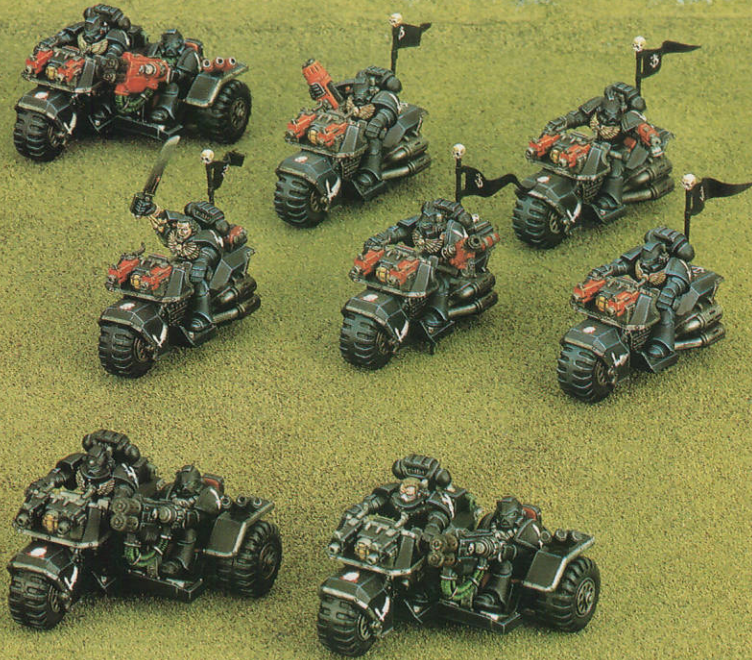

Dark Angels Ravenwing

Unit	WS	BS	S	T	W	I	A	Ld	Save	Notes	Points
☠ Grand Master	5	5	4	4(5)	3	5	4	10	3+	Space Marine bike, Sword of Secrets	155pts
☠ Interrogator Chaplain	5	5	4	4(5)	2	5	4	9	3+	Space Marine bike,	120pts
Command Squad 2 Ravenwing Bikers	4	4	4	4(5)	1	4	1	8	3+	1 meltagun, Techmarine with servo arm	130pts
↑ Bike Squadron											343pts
4 Ravenwing Bikers	4	4	4	4(5)	1	4	1	8	3+	1 flamer, 1 meltagun	
Veteran Sergeant	4	4	4	4(5)	1	4	2	9	3+	Power sword	
1 Attack Bike	4	4	4	4(5)	1	4	2	8	2+	Multi-melta	
↑ Bike Squadron											346pts
4 Ravenwing Bikers	4	4	4	4(5)	1	4	1	8	3+	1 plasma gun, 1 meltagun	
Veteran Sergeant	4	4	4	4(5)	1	4	2	9	3+	Power sword	
1 Attack Bike	4	4	4	4(5)	1	4	2	8	2+	Multi-melta	
▲ Attack Bike Squadron											150pts
2 Attack Bikes	4	4	4	4(5)	1	4	2	8	2+	Multi-meltas	
Vehicle	Armour			BS	Type & Notes	Points					
	Front	Side	Rear								
☒ 3 Land Speeders	10	10	10	4	Heavy bolter, assault cannon, skimmer	255pts					

SEARCH FOR THE HAND OF DARKNESS



Chaos Lord Davey

Playing a battle against somebody you've never played before is always interesting. You have no idea what sort of army they will choose and they often come up with some tactical ploy that you have never had to face before. In this situation I find it is best to go for a well balanced army that will be able to cope with whatever the enemy throws at it.

I also checked out the new Codex rules for the Dark Angels, to see what I might be up against. The main thing that struck me was the Stubborn and Intractable special rules – these Space Marines were NOT going to do much retreating. They would also be quite keen to get their hands on Cypher. After pondering for a while, and looking to see what was available in the Studio cabinets, I decided to go for an army that would be hard to kill – with loads of men, so I could soak up casualties and still keep attacking with (hopefully) the advantage of numbers.

I started with three squads of Chaos Space Marines, two armed with boltguns and one with pistols and combat weapons. Next I went for the familiar choices of a bike squad and a Dreadnought with a plasma cannon (ideal for cutting through Space Marine armour). From the Elites section I chose a Terminator squad, though their weapons were a bit limited by what models were available (not nearly enough lightning claws for my liking).

Still having plenty of points left (the scenario allowed me to take Cypher for free, which was a big bonus), I decided to take a contingent of Nurgle troops. I chose a squad of Plague Marines, led by a Nurgle Sorcerer. I had wanted to try one of these for ages, because they can use the very nasty *Stream of Corruption* psychic power (or Puke Attack, as I tend to call it!). Finally I added a pack of Plaguebearers, to give me even more troops. I ended up with sixty models, which is a lot for a 1,500 point Chaos Space Marine army. I hoped it would be enough.

Trying to decide which strategic option to go for in order to outwit my opponent took me right back to my days of playing Fighting Fantasy adventure game books. Of course with the books I would always cheat by leaving my finger in the previous page, so I could go back if I made the wrong choice. However in this scenario there would be no fingers in pages and no second chances –

I just had to go for it! My usual tactics are to go for the sneakiest option, but just in case Mark knew that, I decided

I should try to do the unexpected by charging straight in and launching an all-out attack. This sort of twisted logic often lands me in trouble, but it did seem to suit Cypher's devious and unpredictable character.

I waited in anticipation to see what strategy Mark had opted for, and if I had made the right decision...

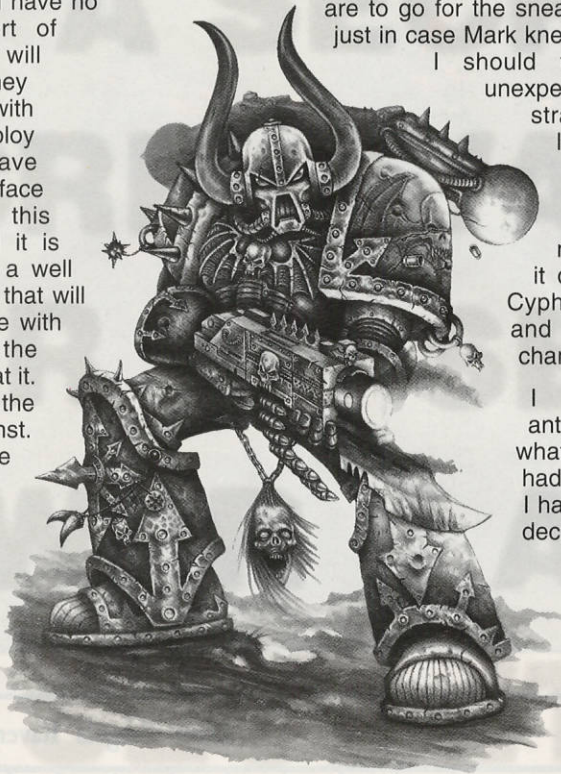

Cypher's Company Chaos Space Marines

Unit	WS	BS	S	T	W	I	A	Ld	Save	Notes	
Cypher	5	6	4	4	3	8	(4)	10	3+	M.c. bolt pistol, m.c. plasma pistol, phase knife	
Sorcerer	5	5	4	5	1	5	(3)	9	3+	Mk of Nurgle, Stream of Corruption, 3 Scrolls, bolt pistol, power sword	76pts
7 Terminators	4	4	4	4	1	4	2	9	2+	1 autocannon, 1 lightning claw, 1 chainfist, 3 melta/bolters	294pts
10 Plague Marines	4	4	4	5	1	4	1	9	3+	1 plasma gun, plague knives, Fearless	206pts
10 Chaos Space Marines Aspiring Champion	4	4	4	4	1	4	(2)	9	3+	Close combat weapons, bolt pistols	180pts
	4	4	4	4	1	4	(3)	10	3+	Power weapon, bolt pistol	
9 Chaos Space Marines	4	4	4	4	1	4	1	9	3+	1 plasma gun, boltguns	141pts
8 Chaos Space Marines	4	4	4	5	1	4	1	9	3+	1 autocannon, boltguns	130pts
5 Chaos Bikers Aspiring Champion	4	4	4	5	1	4	2	9	3+	Close combat weapons	232pts
	4	4	4	5	1	4	3	10	3+	Power weapon, spiky bits	
8 Plague Bearers	4	0	4	5	1	4	2	10	5+		120pts

Armour

Dreadnought	WS	BS	S	Front	Side	Rear	I	A	Notes	Points
Dreadnought	4	4	6(10)	12	12	10	4	3	Plasma cannon, twin linked bolters	115pts



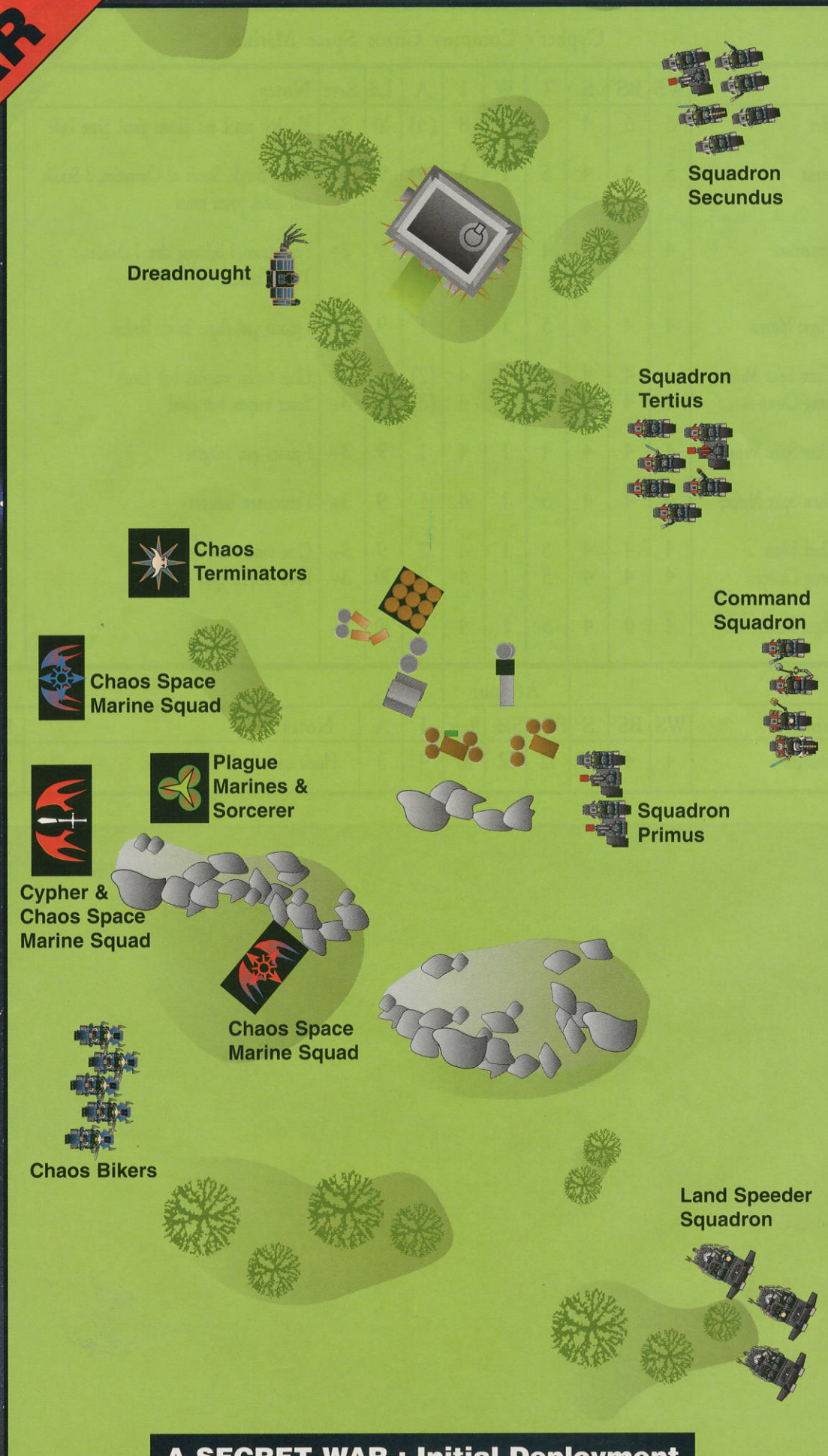

TURN 1

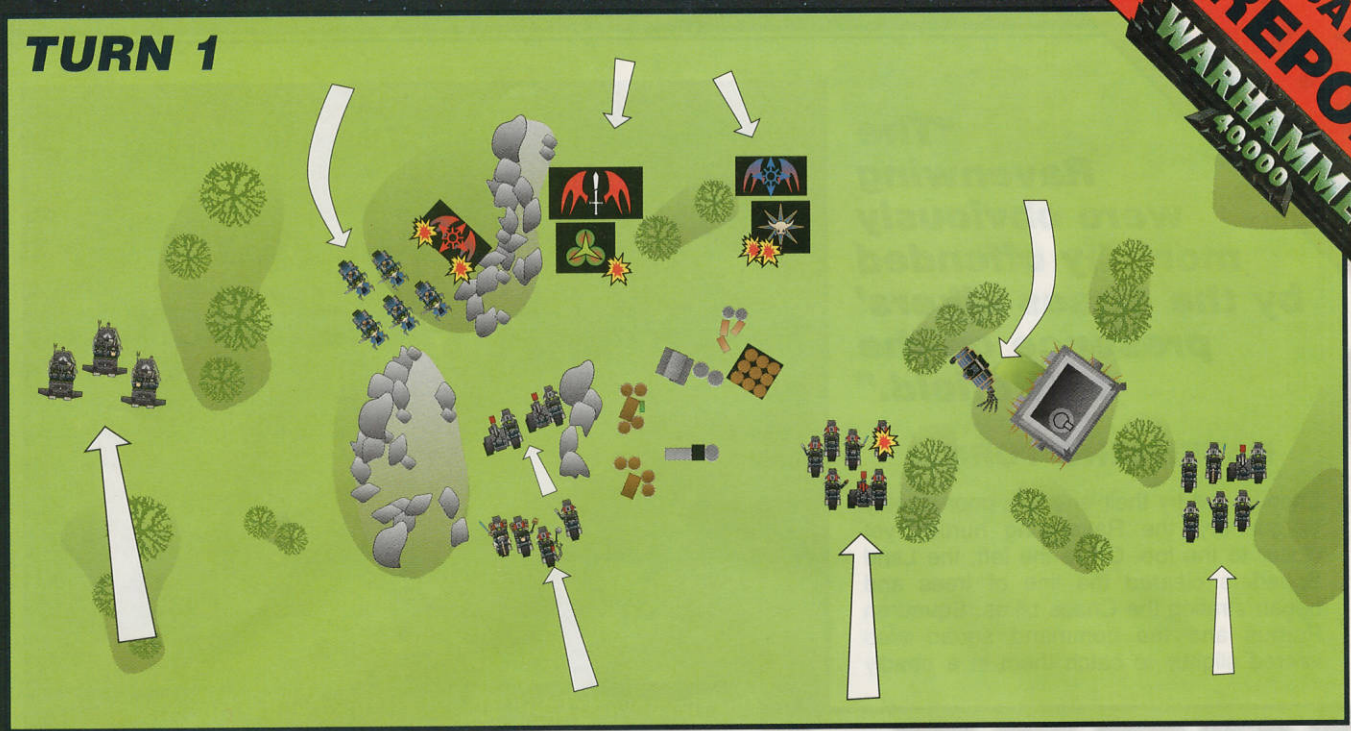

RAVENWING TURN 1

The deep growl of engines rumbled across the plain as the Ravenwing began their charge. The Land Speeder squadron streaked across the table to cover the left flank while Squadron Secundus roared across to take the other flank. The rest of the army surged forwards to deliver a hammer blow to the centre of the Traitor lines. There was no time for fancy manoeuvring, this was an all-out charge!

In the shooting phase, Squadron Primus, ahead of the rest of the army, fired upon the Plague Marines. Despite both the multi-meltas and the twin-linked bolters of the attack bikes blazing away at close range, only one of the vile traitors fell. On the right, Squadron Tertius opened fire upon the lumbering forms of the Chaos Terminators. One fell to the attack bike's multi-melta and Graham was unlucky to lose another to the hail of bolter fire from the rest of the squad. Finally, the Grand Master and the Interrogator Chaplain led by example, shooting dead a Renegade apiece from the squad on top of the hill.

Graham's losses hadn't been particularly severe, but the range was closing fast, next turn he could expect to fare a lot worse.

CHAOS TURN 1

Sensing that the Ravenwing were keen to get to grips, Cypher decided not to disappoint them. As one, practically the whole Chaos army strode forwards to meet the foe. Only the squad of Chaos Space Marines on the hill stayed in position, to give supporting fire with their autocannon. Unfortunately, a combination of Chaos bloodlust and the high speed of the enemy made for appalling marksmanship as, despite the storm of fire that erupted around the enemy, the only casualty was a bike from Squadron Tertius, vapourised by the Chaos Dreadnought's plasma cannon. Everywhere else, shots either went completely wide or pattered harmlessly off the sinister, black armour of the Ravenwing. Dishonourable mention must go to the Chaos Terminators who managed to miss every single one of their shots, even with re-rolls!



The Ravenwing speed across the plains, directly towards the Chaos army.

“The Ravenwing were obviously mortally offended by the Chaos bikers’ presence on the battlefield.”

RAVENWING TURN 2

Encouraged by their enemy’s poor display of gunnery, the Ravenwing hurtled yet closer to the foe. Off to the left, the Land Speeders cleared the line of trees and began strafing the Chaos bikes. Squadron Primus and the command squad also veered slightly to catch them in a deadly



The Ravenwing Land Speeders strike at the Renegades.



TURN 2

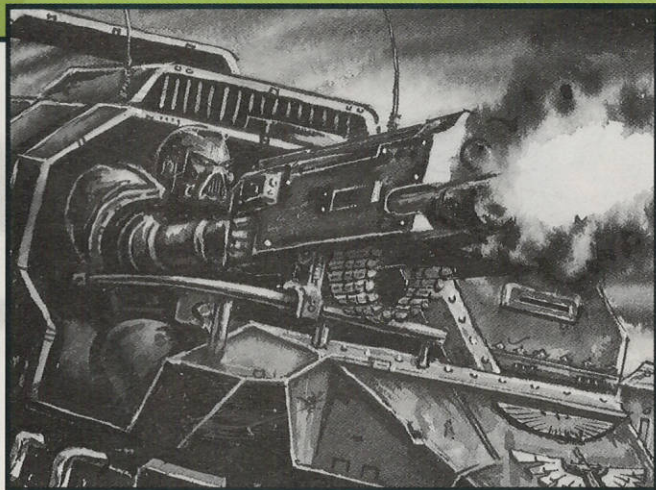

crossfire. The hail of shells from the Land Speeders’ three assault cannons accounted for one, two more were fused to slag by the attack bikes of Squadron Primus, leaving the last two Chaos bikes to be picked off by the command squad. The Ravenwing were obviously mortally offended by the Chaos bikers’ presence on the battlefield. If there were going to be bikes then they were going to be black! Meanwhile Squadron Tertius was having a bad time against the Chaos Dreadnought. Although the multi-melta managed to completely destroy its close combat weapon, the rest of the squad’s fire, including the meltagun, had absolutely no effect. Graham breathed a sigh of relief and Mark prepared to receive the enraged machine’s charge.

CHAOS TURN 2

The gap between the two armies was narrowing all the time. With a sinking heart, Mark realised that not only would the Dreadnought be able to assault Squadron Tertius but the Chaos Terminators would as well! In addition to this, the Plague Marines would easily be able to reach Squadron Primus and the command squadron. Things looked bleak for Mark, his lightning-fast army was about to get bogged down in a close combat where Graham had all the advantages.

Before that however, Graham had all his shooting to do. The Dreadnought and the squad of Night Lords just behind it killed another two bikers from Squadron Tertius. The Terminators chose not to fire upon the bikes but instead swung round to bring their weapons to bear upon the Land Speeders. Only the autocannon was in range but the ancient Marine redeemed his squad's previous poor show by destroying the assault cannon on one and inflicting a crew shaken result on a

second. The Chaos Space Marines on the hill also fired upon the Land Speeders, but despite unleashing everything they had at them, could only cause a second crew shaken result.

In the centre of the battlefield, the remainder of the Chaos army poured fire into the command squadron and Squadron Primus, in an attempt to soften them up before the assault. But a lucky series of 'jink' rolls and armour saves saw only one of the Ravenwing fall – shot down by Cypher himself!

Now came the assault. As expected, the Terminators charged into Squadron Tertius. However the Dreadnought didn't join in, as Graham felt that, without its combat weapon, it was more use out of combat. The Ravenwing Veteran Sergeant valiantly cut down one of the massive warriors but in return the Terminators smashed apart the other bike and the attack bike. Realising that the situation was lost, the

Sergeant fell back (we were using the optional rule allowing Mark to voluntarily fail his test, quite sensibly realising that there could only be one outcome in a fight between the Sergeant and four Terminators). Before the Plague Marines rushed in, the Sorcerer unleashed his vile *Stream of Corruption* over both the attack bikes of Squadron Primus. This horrifying attack would have killed one, but the rider frantically slewed his machine round, the Ravenwing jink saving him from an extremely unpleasant fate. In the combat, the Grand Master killed two of the Plague Marines who managed in return to kill the crew from an attack bike. Though they had lost, the Plague Marines' Fearless rule meant that they would not retreat. With Cypher and his retinue coming in fast, it looked bleak for the Ravenwing.



Chaos Terminators charge at the speeding bikes.



After being vomitted on, the attack bikes are then assaulted by the Plague Marines.

TURN 3

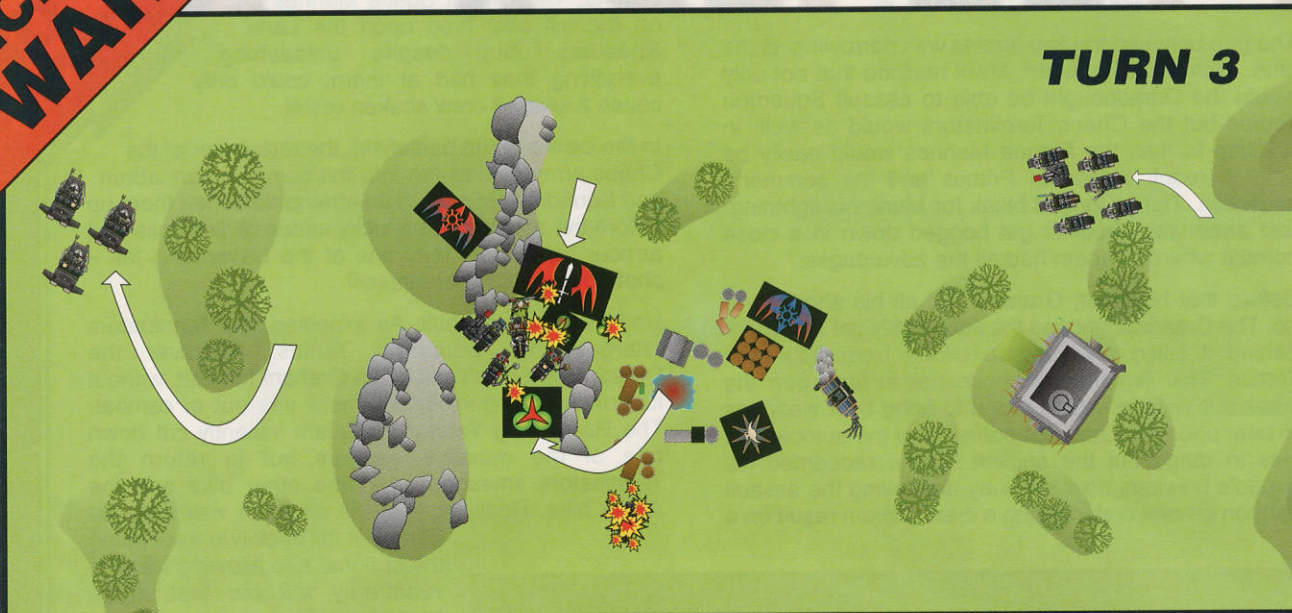

RAVENWING TURN 3

After the pounding that they had suffered in the previous turn, the Land Speeders retreated back over the trees to regroup. On the right flank, Squadron Secundus rounded the woods and entered into the fray, opening fire upon the nearest squad of Night Lords. However they found that the range was too great for accurate shooting and all of their shots either went wide or failed to wound. The only other shooting was the Veteran Sergeant of Squadron Tertius (now all on his own), who spotted the Chaos Sorcerer, isolated from the Plague Marines, and shot him dead from extreme range. The rest of the Ravenwing was still locked in mortal combat with the Plague Marines.

The Grand Master killed two more Plague Marines as did the Chaplain. The Techmarine crushed a fifth with his servo-arm, while the Plague Marines failed to damage any of the bikes. Still the Ravenwing were trapped in the combat and there was little that Mark could do about it.



Flanking bikers speed through the clearing.

CHAOS TURN 3

The lone Veteran Sergeant was the only target in range of the Chaos army's guns. As one, all the Chaos squads that weren't in combat brought their weapons to bear upon him. He simply vanished under the hail of fire, the plasma cannon of the Dreadnought dealing the fatal blow.

The main event this turn was the assault phase. Cypher and his men would be able to reach the Ravenwing command squad – the key fight of the battle was shaping up. First though, Graham managed to summon his Plaguebearers. These appeared near to the Terminators and were just in range to join in the assault on the command squadron and Squadron Primus. Cypher must have been completely overcome at finally getting his hands on his old comrades because he missed every single one of his attacks! The Dark Angels Grand Master however, driven by his righteous fury at Cypher's treachery, struck him hard, reducing the Fallen Angel to only one wound. The rest of the Renegades followed their leader's example and all missed or failed to wound as well. The only other casualty was the Techmarine, who fell to a Plaguebearer.

"The Veteran Sergeant simply vanished under the hail of fire."



Doomed!



Outnumbered five to one, the command squad fight on, determined to kill Cypher.

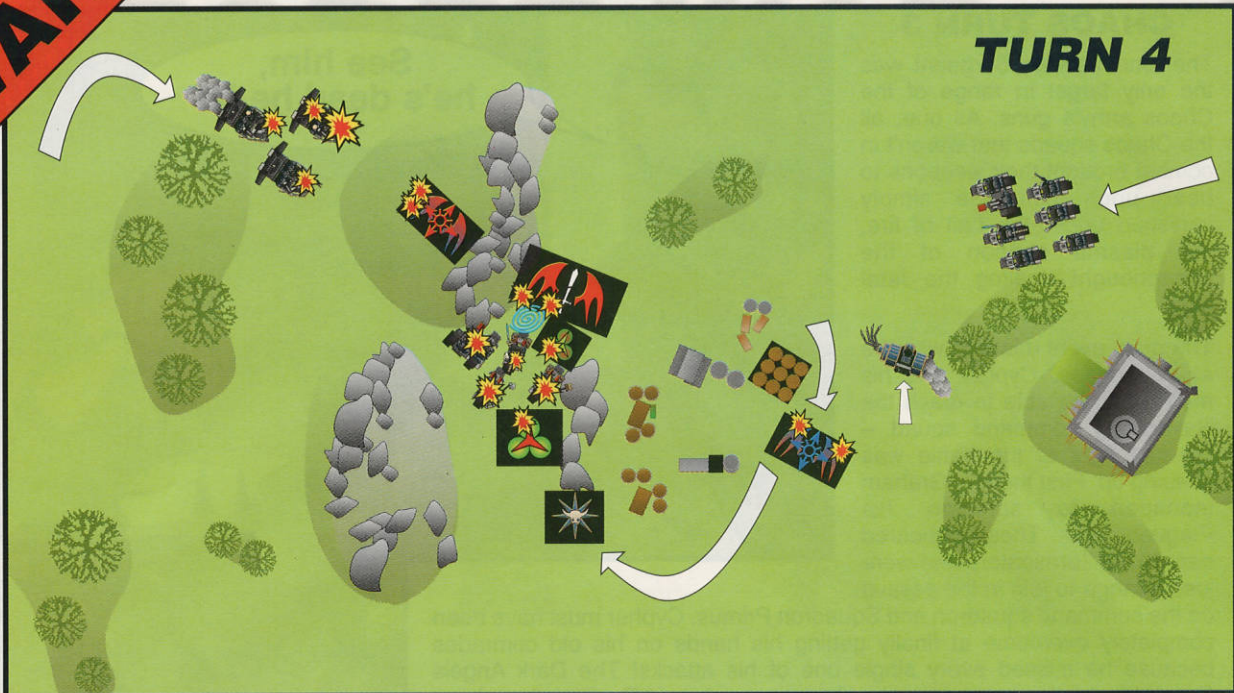

RAVENWING TURN 4

Once again the Land Speeders zoomed over the trees to shoot up the Night Lords squad that had battered them before. This time two more of the traitors died but their resolve held firm and the Chaos Space Marines prepared to return fire in their own turn. Squadron Secundus fired again at the squad of Renegades that had escaped their wrath in the previous turn. Their aim was better this time but even so, only two Renegades were slain by the hail of fire from the bikes.

The decisive combat was still in full swing in the centre of the table. This time Cypher recovered himself and inflicted two wounds on the Grand Master, who in return

swung a mighty blow that would have carved the traitor in two. But to the Dark Angels' disgust, the fickle powers of Chaos whisked the Fallen Angel away before the blow could connect, depriving the Grand Master of perhaps the greatest possible prize for his Chapter.

This cataclysmic struggle cast such a shadow over the rest of the combat that nobody else managed to kill their foes.

CHAOS TURN 4

This time the Land Speeders were easily the best target for the Chaos army. A veritable blizzard of fire engulfed them until two of the machines had crashed, littering the edge of the wood with burning wreckage. The third was hardly in better shape, the assault cannon had been reduced to fused and twisted metal, and the crew were fighting to regain control.

With Cypher gone, the Grand Master was able to concentrate his attacks upon the Chaos troops, with devastating effect. Four fell to the ancient Sword of Secrets. But the followers of Chaos recovered well from the disappearance of their leader. Between them they managed to kill the attack bike and the Chaplain, leaving the Grand Master alone to fight the remaining Night Lords, the last two Plague Marines and the Plaguebearers.



Chaos Terminators approach, ready to join the already one sided fight.

RAVENWING TURN 5

Deciding that things were definitely too hot for the moment, the crew of the sole surviving Land Speeder once again retreated behind the safety of the trees. Squadron Secundus, on the other flank, moved into danger, deciding to unload all their weaponry into the Dreadnought, at point blank range. They were more successful than the ill-fated Squadron Tertius had been, and the ancient machine toppled to the ground, scorched and blackened almost beyond recognition. Battling alone, the heroic Grand Master managed to kill the Night Lords Champion but no more. In return the forces of Chaos failed to wound him. The combat would drag on yet longer!



The damaged Land Speeder ducks behind cover.

“They were more successful than the ill-fated Squadron Tertius had been, and the ancient machine toppled to the ground...”



Squad Secundus arrive, ready to take on the Dreadnought.

RAVENWING TURN 5





“The Terminators and the nearest squad of Renegades unleashed everything they had at the Landspeeder...”

CHAOS TURN 5

The Land Speeder was out of sight, the Grand Master was in combat and everything else was dead except for Squadron Secundus. So the Chaos army fired at that. The Terminators all proved to be terrible shots – yet again! The autocannon on the hill failed to penetrate the Space Marine armour and all the bolters were out of range. Squadron Secundus roared onward through the maelstrom, unscathed. The close combat was bloody and at last decisive. The Grand Master cut down another Plague Marine and two more of the Renegades but was himself killed by the last Plague Marine. Free to manoeuvre at last, the surviving Night Lords, the solitary Plague Marine and the more or less intact Plaguebearer pack made a sweeping advance towards Squadron Secundus.

RAVENWING TURN 6

With only one squad and a Land Speeder left, the Ravenwing turn was over very quickly. The multi-melta of Squadron Secundus incinerated another Terminator, crucially taking the squad down below half strength, while the Land Speeder took a chance and moved into Graham’s deployment zone hoping that it would survive long enough (in the Recon mission, bonus victory points are earned for squads or vehicles in the enemy’s deployment zone at the end of the battle). Its heavy bolter fired again at the Renegades on the hill, but despite all three shots hitting and wounding, only one Chaos Marine fell.

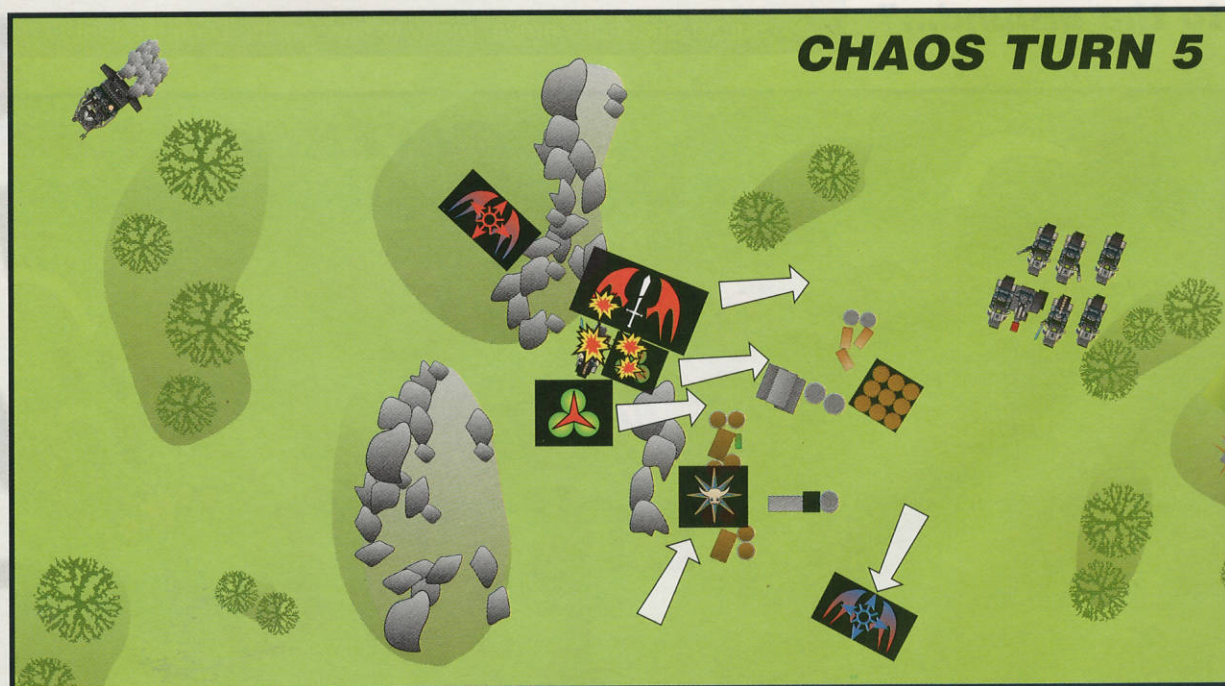

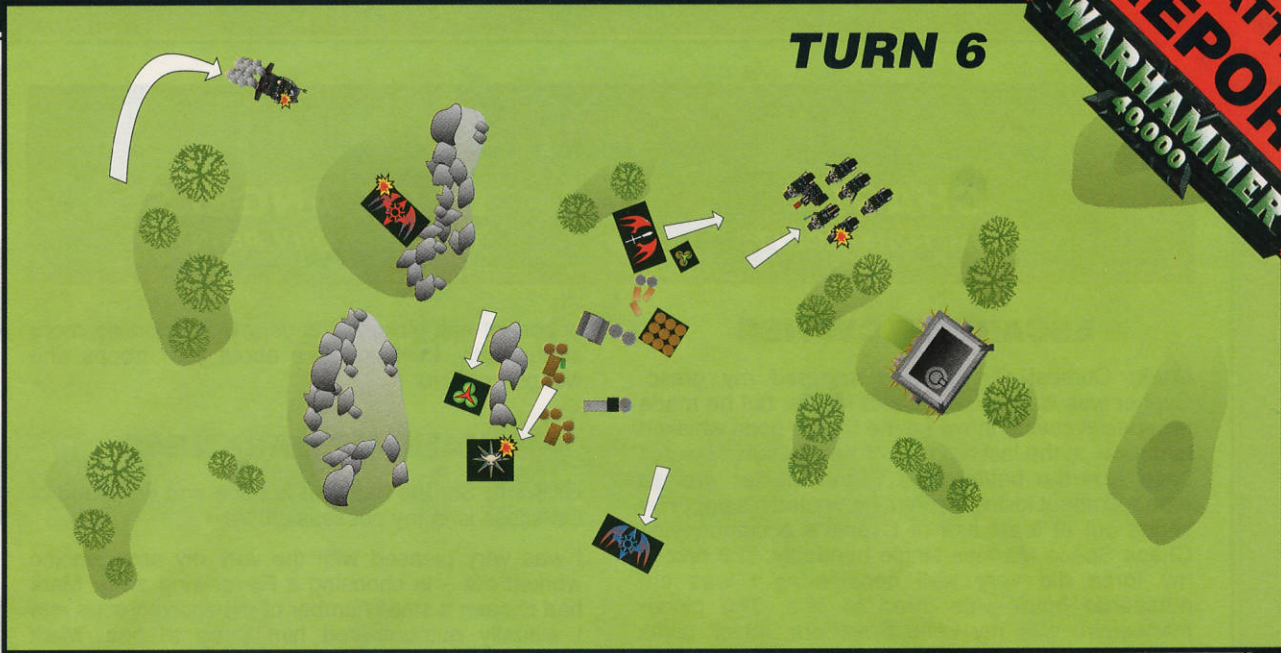

CHAOS TURN 6

While one squad of Night Lords ran for the Ravenwing deployment zone, the rest of the army tried to wreck what was left of the Ravenwing. The Terminators and the nearest squad of Renegades unleashed everything they had at the Land Speeder, but couldn't bring the agile machine down, merely wrecking the heavy bolter. The other squad of Renegades opened up on Squadron Secundus, but only the plasma gun managed to overcome the armour of the black-clad bikers, leaving the squad still above half strength.

The game itself was great to watch. Mark went straight forwards into the Chaos lines, which made for a marvellous spectacle – a brave, if not foolhardy move. The thing that everybody wanted to see – a fight between the Grand Master of the Ravenwing and Cypher – happened, and what a fight it was. For two turns they both whacked the hell out of each other, the Sword of Secrets and the Grand Master's Toughness 5 just giving him the edge.

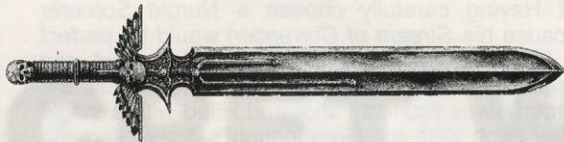

CONCLUSION

With that, the battle was over. As the din of bolter fire slowly receded we added up the victory points, fully expecting Graham to have scored a convincing victory. In the event it was very close. Chaos had scored 1,028 victory points plus a bonus 200 for getting a squad above half strength into the Ravenwing deployment zone, for a total of 1,228. The Ravenwing had scored 828 points plus a bonus 300 for a squad above half strength and a damaged vehicle in the Chaos deployment zone, making a grand total of 1128. Only a hundred points in it at the death. If Cypher had failed his special save (admittedly not very likely) or if the last Plague Marine had been killed in the close combat then Mark would actually have scraped a narrow win! Having said that, Graham's victory, on the table at least, was secure. There were only five Ravenwing models left on the battlefield – one of them without any weapons at all – and plenty of Chaos followers to mop them up with.

It was a brave move by Mark to take an entire army of Ravenwing. At 40+ points each, he knew that Graham would have the advantage of numbers and was relying on manoeuvrability and Toughness 5 to get him out of trouble. Unfortunately, getting swamped by the Chaos army cost him his speed advantage and from there it all went downhill. The Ravenwing will be a very difficult army to use effectively but devastating in the right circumstances.

Graham is a veteran Chaos commander and knows exactly how to use his army to best advantage. Even with consistently awful shooting phases, he still managed to practically annihilate the Ravenwing.

All this considered, the close result was a bit of a surprise but a welcome one nonetheless. Mark has been seen buying worrying numbers of Space Marine bikes and Land Speeders from Mail Order. A Ravenwing army from him cannot be far away now, and when it's finished, we'll show it to you. Graham had never used Cypher before and his experience in this battle has made him think again. Cypher is a very useful character with a lot of advantages, especially when fighting a Dark Angels army (the Deathwing have to move towards him, so a clever Chaos commander can use this to his advantage).

Now that Cypher and the vile forces of Chaos have the Hand of Darkness, no one is safe!

RESULTS

CHAOS

1228 VICTORY POINTS

DARK ANGELS

1128 VICTORY POINTS

ESCAPE OF CYPHER

Mark: Curses! Cypher has escaped my grasp. Cypher was slain by my Grand Master but he made his special saving throw so the Chaos gods whisked him away at the last moment (if he had failed I would have won the battle!). My Grand Master was so enraged about losing Cypher, he vented his anger by taking out at least half of Cypher's accompanying Chaos Space Marines single handedly. The rest of my force did very well considering I was outnumbered figure-wise three to one. The pincer manoeuvre with my Land Speeders, attack bikes and HQ went very well against the Chaos bikers (they were wiped out before they could get off a shot). Using Land Speeders in a hit and run way is the best tactic for them – trying to slug it out with Chaos Space Marines doesn't really work. Destroy a target then run for cover (you stay alive longer). Jink is also a useful rule for Ravenwing and so it proved in the battle (once when Cypher took a shot at my bikes and the other when the Chaos Sorcerer used *Stream of Corruption* against my attack bikes).

The lone Veteran Sergeant biker who voluntarily withdrew from combat with the Terminators, only to turn his bike and gun down the Sorcerer, did put a smile on my face (n.b. a *stubborn* Deathwing Sergeant would not have been allowed to withdraw). It was short lived though, as he was promptly shot down by fire from over half the Chaos army.

On the whole my force did well, but they were finally whittled away by the weight of enemy numbers.

The few shall be honoured amongst the Chapter's hall of heroes. I thought the idea of the secret scenario worked well. Not knowing what your

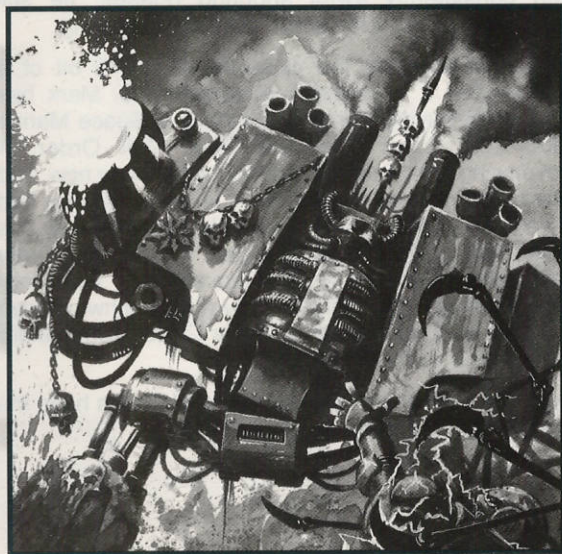

opponent has picked gets your brain working more strategically, thinking more about your troops and weapon options.

HAND OF DARKNESS

Graham: So, the battlefield is mine and the Hand of Darkness is in my possession!

I was very pleased with the way my army choice worked out – in choosing a Ravenwing army, Mark had chosen a small number of expensive troops and I actually outnumbered him three to one. Mark fielded an alarming number of melta weapons, which worried me at first, but my large force just soaked up the shooting casualties without causing any major problems. Even when my Bike squad was mown down in a nasty Ravenwing pincer move, it was only a loss of 5 models out of 60. However, when the Dark Angels lost their first Bike squad, not long afterwards, it was 5 models out of 20 – an entire quarter of the army! Of course, not caring about casualties amongst his troops particularly suits Cypher's cynical motives, whereas it is only right that the Ravenwing Master should feel deeply the loss of every one of his men.

But this was not an easy battle by any means. With their Toughness 5, power armour and very irritating 'jink', the Ravenwing bikers were extremely hard to kill! Having carefully chosen a Nurgle Sorcerer because his *Stream of Corruption* would be perfect for killing bikers, the one he wounded went and jinked out of the way! And to add further insult, the Sorcerer was promptly shot and killed with a single bolter shot! With the Dreadnought's power scourge being blown off early in the game, only my Terminators could reliably tear apart the bikers without getting stuck in a long, drawn out combat. The Ravenwing command squad held out for ages, even though they were up against three entire Chaos squads. Before they succumbed, they took down all but one of the Plague Marines, half the close combat squad and Cypher himself (though he made his special save and disappeared to safety).

In the end, the victory point totals were quite close (although I lost a few bonus points because my troops got carried away charging after Mark's last squad and forgot that their mission objective was to get into the enemy deployment zone!). It was an exciting game, especially because of the scenario and the player briefings. And I love the way the story ties in with the Battlefleet Gothic background. Two things have really stuck in my mind from this battle: how effective taking lots of troops was, and secondly, what are Cypher's real motivations? Does he have a noble goal or is he merely a pawn in some twisted plot of the Chaos god Tzeentch? Whatever the truth, he will go to any lengths to get what he wants...

GAMES WORKSHOP®

MAIL ORDER

- **MUSTER THE FLEETS!**
Eldar ships warp in for Battlefleet Gothic
- **CHAOS SPIKY BITZ!**
- **GRAND MASTERS!**
Characters of the Dark Angels Chapter
- **RAVENWING ATTACK...**
Great army deal!
- **LAUNCH FIGHTERS!**
Battlefleet Gothic attack craft
- **BOLOGS!**
You've seen the Giants of Albion!
Now check out the other Regiments of Renown!
- **DIE-DIE, MAN-THING!**
Skavenslaves and the new Skaven shield sprue



ANYTHING AT ALL - GIVE US A CALL

☎ **0115 91 40000** ☎

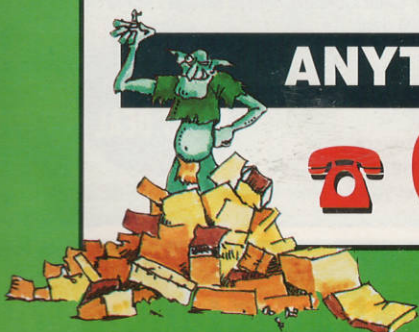

BATTLEFLEET GOTHIC

Battlefleet Gothic, the game of spaceship battles, is set during the Gothic War in the 41st Millennium; a grim time when the Imperium of Man battles for survival in a hostile galaxy. Battlefleet Gothic lets you command fleets of warships in deadly conflict among the stars, though whether as Mankind's saviour or its destroyer is up to you!

In this box is all you need to fight exciting space battles:

Battlefleet Gothic rulebook with campaign rules, 4 Imperial Cruisers (multi-part kits), 4 Chaos Cruisers (multi-part kits), 12 assorted dice, Fleet Registry roster pad, 2 plastic range rulers, over 100 game counters, 2 reference sheets, Getting Started guide with exclusive comic strip.



**BATTLEFLEET
GOTHIC
BOXED GAME
£40**

**£8
EACH**

**SHADOW
CLASS
ELDAR
CRUISER**

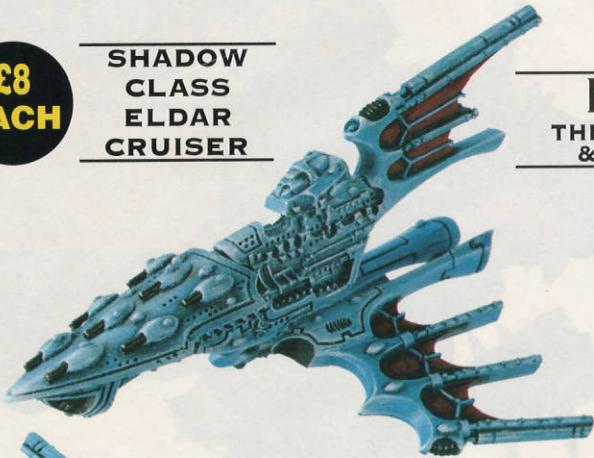

ELDAR FLEET

THE ELDAR ARE THE MOST GRACEFUL & DEADLY RAIDERS IN THE GALAXY

Eldar Fleet designed by Tim Adcock.

Eldar cruisers shown at approximately 90% actual size.

NEW

**£5
FOR 2
OR £2.50
EACH**

**HELLEBORE CLASS
ELDAR FRIGATES**



**£5
FOR 3
OR £1.75
EACH**

**HEMLOCK CLASS
ELDAR DESTROYER**



**ECLIPSE
CLASS
ELDAR
CRUISER**

**£8
EACH**

**£5
FOR 3
OR £1.75
EACH**

**ACONITE CLASS
ELDAR FRIGATES**



**NIGHTSHADE
CLASS
ELDAR DESTROYER**

**£5
FOR 3
OR £1.75
EACH**



ELDAR CORSAIRS FLEET



The Gothic Sector is exposed! Now is the time to plunder this sector and to teach these inferiors that they were fools to think they had mastered the galaxy! To help you gather an Eldar Corsairs fleet to ravage Gothic Sector, we have come up with this special deal:

- Eclipse class cruiser
- Shadow class cruiser
- 2 Hellebore class frigates
- 3 Aconite class frigates
- 3 Nightshade class destroyers
- 3 Hemlock class destroyers

**£36
FLEET DEAL**

All for £36, and we'll also send you 2 Fighter & 2 Bomber wings FREE!

IMPERIAL NAVY

THE MIGHTY IMPERIAL NAVY PROTECTS & ENFORCES THE PAX IMPERIALIS

Imperial Fleet designed by Dave Andrews. Battleships shown at approximately 90% actual size.

£5
FOR 4
OR **£1.25**
EACH

**COBRA CLASS
IMPERIAL DESTROYER**

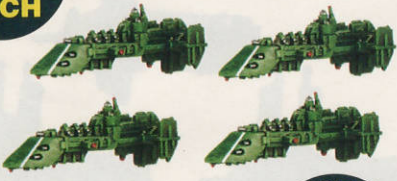

£12
BOXED
SET

**RETRIBUTION CLASS
IMPERIAL BATTLESHIP**

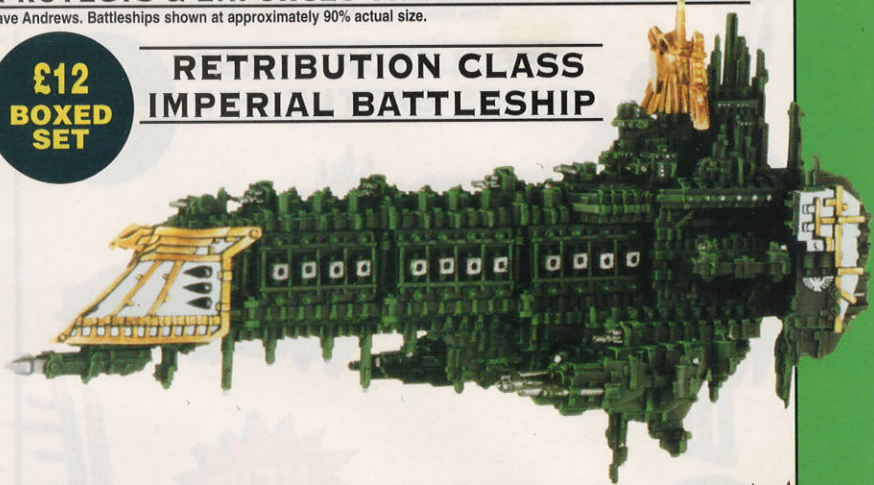

**SWORD CLASS
IMPERIAL FRIGATES**

£5
FOR 3
OR **£1.75**
EACH

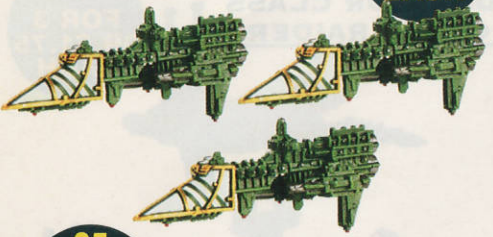

£12
BOXED
SET

**EMPEROR CLASS
IMPERIAL
BATTLESHIP**

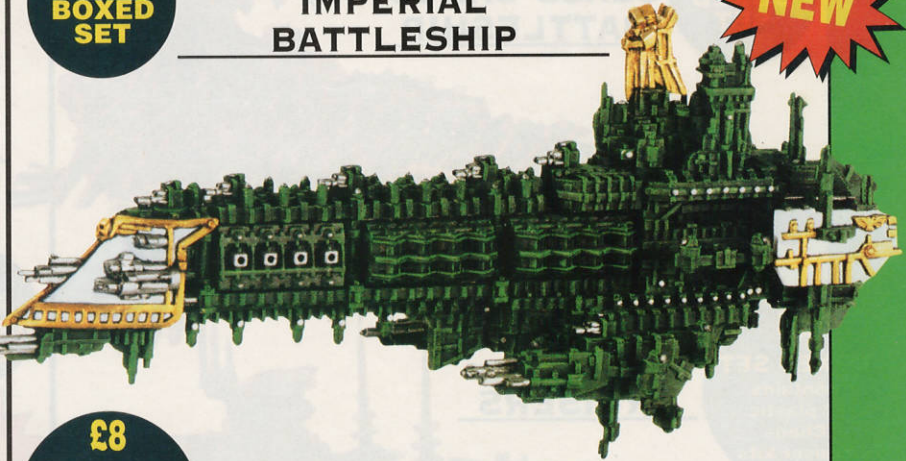

£5
FOR 3
OR **£1.75**
EACH

**FIRESTORM CLASS
IMPERIAL FRIGATES**



£8
BOXED SET
contains
2 plastic
Imperial
Cruiser kits

IMPERIAL CRUISERS

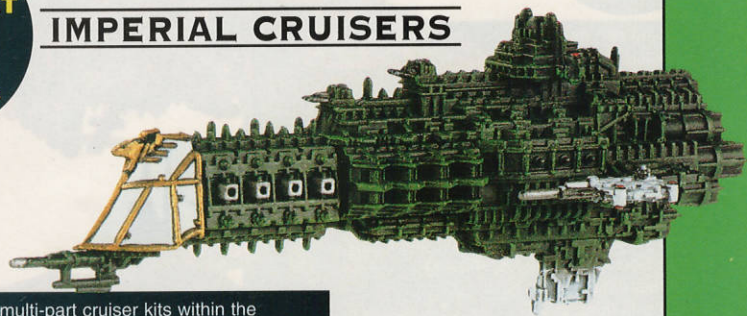
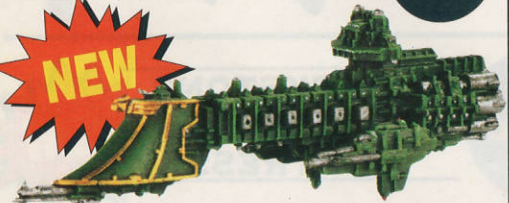

**DAUNTLESS CLASS
IMPERIAL LIGHT CRUISER**

£5
EACH

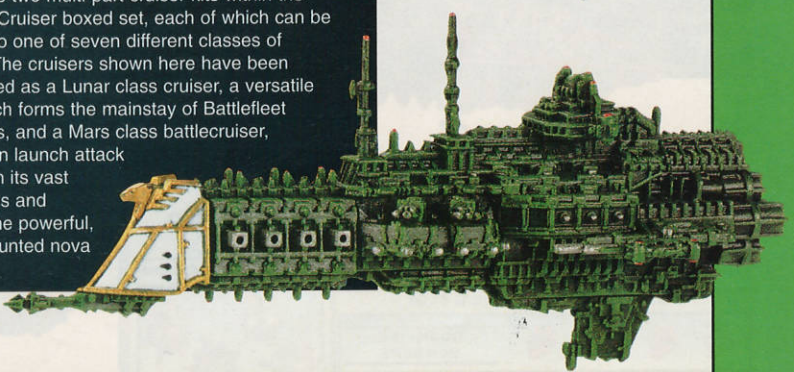

There are two multi-part cruiser kits within the Imperial Cruiser boxed set, each of which can be made into one of seven different classes of cruiser. The cruisers shown here have been assembled as a Lunar class cruiser, a versatile ship which forms the mainstay of Battlefleet Obscurus, and a Mars class battlecruiser, which can launch attack craft from its vast flight bays and carries the powerful, prow-mounted nova cannon.



IMPERIAL ATTACK CRAFT	
Designed by Dave Andrews	
	FURY INTERCEPTORS
FURY INTERCEPTOR WING £1.00	
	STARHAWK BOMBERS
STARHAWK BOMBER WING £1.00	
	SHARK ASSAULT BOATS
SHARK ASSAULT BOAT WING £1.00	

CHAOS WARFLEETS

THE CHAOS WARFLEETS HAVE COME TO BRING DEATH TO A THOUSAND WORLDS

Chaos Fleet designed by Tim Adcock. Battleships and Blackstone Fortress shown at approximately 90% actual size.

DESOLATOR CLASS CHAOS BATTLESHIP

£12
BOXED
SET



INFIDEL CLASS CHAOS RAIDER

£5
FOR 3
OR £1.75
EACH



IDOLATOR CLASS CHAOS RAIDER

£5
FOR 3
OR £1.75
EACH



£12
BOXED
SET

DESPOILER CLASS CHAOS BATTLESHIP



£5
FOR 3
OR £1.75
EACH

ICONOCLAST CLASS CHAOS DESTROYER



£8
BOXED SET
contains
2 plastic
Chaos
cruiser kits

CHAOS CRUISERS

There are two multi-part cruiser kits within the Chaos Cruiser boxed set, each of which can be made into one out of seven different classes of Chaos cruiser. The cruisers shown here have been assembled as a Murder class cruiser, which was the most numerous Chaos vessel during the invasion of the Gothic Sector, and the fast moving Slaughter class, which is armed with lances and heavy batteries.

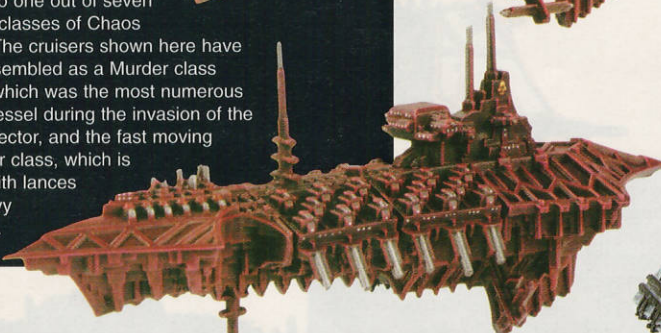

£12
BOXED
SET

BLACKSTONE SPACE FORTRESS

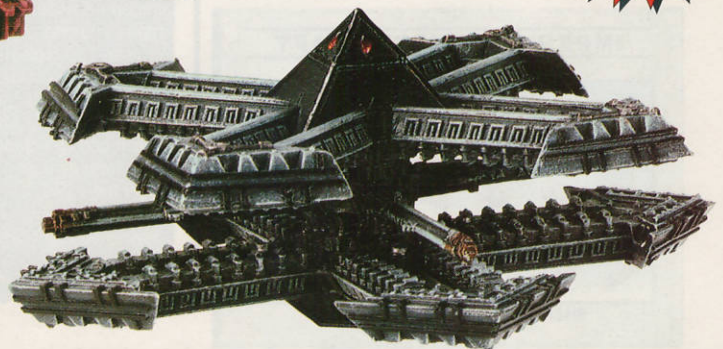

CHAOS ATTACK CRAFT

Designed by Tim Adcock



SWIFTDEATH
FIGHTERS

SWIFTDEATH FIGHTER WING £1.00



DOOMFIRE
BOMBERS

DOOMFIRE BOMBER WING £1.00

MINE CLUSTER

£1.00

Designed by Dave Andrews



CODEX™

DARK ELДАР®

£8
BOOK

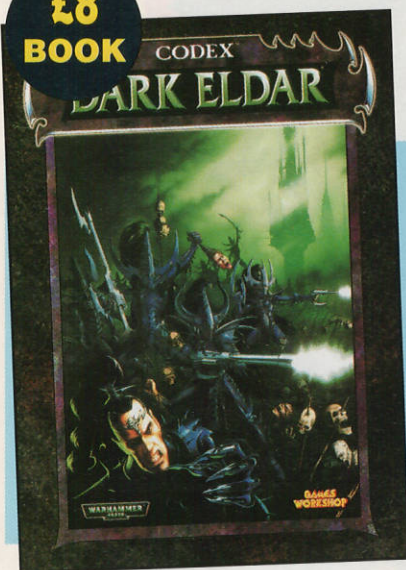

CODEX DARK ELДАР

This 48 page Codex contains the army list, background and rules for one of the most evil races in the Warhammer 40,000 universe.

For more tips on how to fight or defend against the Dark Eldar, check out 'Watch the Shadows' in this White Dwarf.

£6



DRAZHAR
MASTER OF BLADES

Designed by Chris FitzPatrick

NEW

£6



DARK ELДАР LORD

Designed by Gary Morley

NEW

DARK ELДАР WARRIORS

Designed by Gary Morley



£10
Plastic
boxed set

DARK ELДАР RAIDER

Designed by Tim Adcock
& Gary Morley



£12
Plastic
boxed set

£18
Boxed
set

REAVER JETBIKE SQUAD

Designed by
Chris FitzPatrick &
Dave Andrews



DARK ELДАР MANDRAKES

Designed by Gary Morley

For full size pictures and tips on how to use or guard against these nightmare infiltrators, check out 'Watch the Shadows' in this White Dwarf!

£5
FOR 3
OR £1.75
EACH

NEW



MANDRAKE 1



MANDRAKE 2



MANDRAKE 3



MANDRAKE 4

£15
Boxed
set

DARK ELДАР TALOS

Designed by Mark Bedford

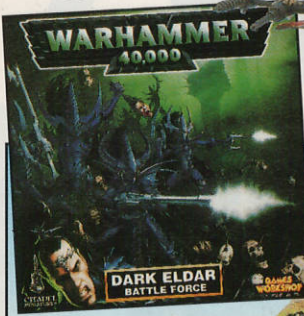

DARK ELДАР BATTLE FORCE

£40 BOXED SET

Dark Eldar Battle force contains: 20 plastic Dark Eldar Warriors, 1 Dark Eldar Raider, 5 Reaver jetbikes & Warhammer 40,000 tree sprue (enough components to make 4 Jungle trees).

Designed by Gary Morley, Tim Adcock & Dave Andrews



CODEX™ DARK ANGELS®

**£4
BOOK**

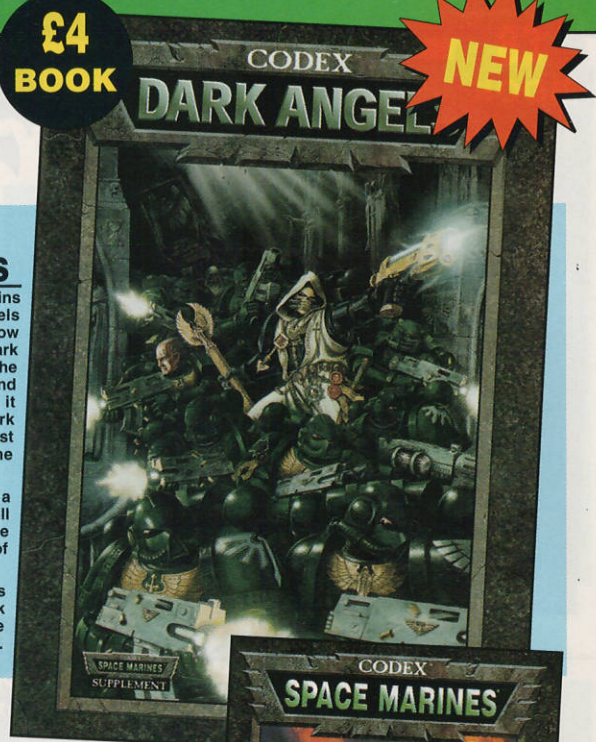

NEW

£6



Designed by Jes Goodwin

SPACE MARINE COMMANDER
IN TERMINATOR ARMOUR

CODEX DARK ANGELS

This 24 page Codex contains the unique Dark Angels organisation and the full low down on all the special Dark Angels rules, troops (like the deadly, fast Ravenwing) and awesome wargear. Plus it reveals some of the dark secrets of one of the most mysterious Space Marine Chapters in the Imperium.

Codex Dark Angels is not a stand alone Codex. You will need a copy of Codex Space Marines to make full use of the Dark Angels army list.

Check out this month's battle report as the Dark Angels Ravenwing battle against the forces of Chaos.

**£5
EACH**

DEATHWING TERMINATORS

Designed by Jes Goodwin



DARK ANGELS RAVENWING COMMAND SQUAD

Designed by Jes Goodwin & Mike McVey

**£20
Boxed
set**



NEW

**£8
BOOK**

CODEX SPACE MARINES

This 48 page Codex contains the army list, background, and rules for the Space Marines, the most powerful and feared of all the Emperor's warriors.



SPACE MARINE LANDSPEEDER TORNADO

Designed by Jes Goodwin

**£17
Boxed
set**



DARK ANGELS SPECIAL CHARACTERS

Designed by Jes Goodwin

£7

SUPREME GRAND MASTER AZRAEL
& WATCHER IN THE DARK

£6

GRAND MASTER
LIBRARIAN EZEKIEL

£6

INTERROGATOR
CHAPLAIN ASMODAI

£4

DARK ANGELS
STANDARD BEARER

£4

DARK ANGELS
SERGEANT

RAVENWING ASSAULT FORCE

**£89
ARMY
DEAL**



The Ravenwing are a vital tool in the Dark Angels' unrelenting hunt of the Fallen. To make it easier to marshal the Ravenwing for an assault we have put together this special Mail Order army deal.

- **RAVENWING COMMAND SQUAD**
- **5 SPACE MARINE BIKES**
- **2 LANDSPEEDER TORNADOS**
- **SPACE MARINE ATTACK BIKE**

All for £89 with **FREE!** Advance Order postage.

Plus we will also send you 6 **FREE!** Ravenwing torsos and 8 **FREE!** Ravenwing shoulder pads.

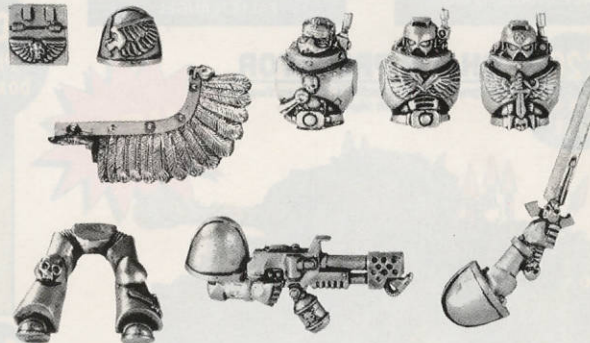

The Ravenwing torsos, shoulder pads, arms, legs, wings and pannier box are available separately from Mail Order. Give us a ring for details.



SPACE MARINE COMMAND SQUAD
£15 boxed set

Space Marine Command Squad contains: Commander, Standard Bearer, Apothecary, Techmarine & Veteran Sergeant

Designed by Jes Goodwin



SPACE MARINE TACTICAL SQUAD
£10 boxed set

Space Marine Tactical Squad contains: enough parts to make a 10-man Tactical squad with Sergeant, Marine with missile launcher & Marine with flamer

Designed by Jes Goodwin



SPACE MARINE ASSAULT SQUAD

£10 boxed set

Space Marine Assault Squad contains: enough parts to make a 5-man squad with assault weapons and jump packs

Designed by Jes Goodwin

SPACE MARINE DEVASTATOR SQUAD
£15 boxed set

Space Marine Devastator Squad contains: Sergeant, Marine with missile launcher, Marine with lascannon, Marine with heavy plasma gun & Marine with heavy bolter (or give Mail Order a ring and choose any heavy weapon combination you wish)

Designed by Jes Goodwin



SPACE MARINE BATTLE FORCE

£40 Boxed set

This boxed set contains:
1 Tactical squad,
1 Terminator squad,
1 Landspeeder,
3 Space Marine bikers and
1 Gothic Ruins sprue

Designed by Jes Goodwin

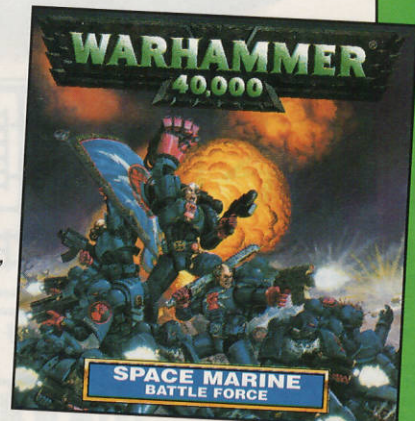

CODEX™ CHAOS SPACE MARINES

**£8
BOOK**

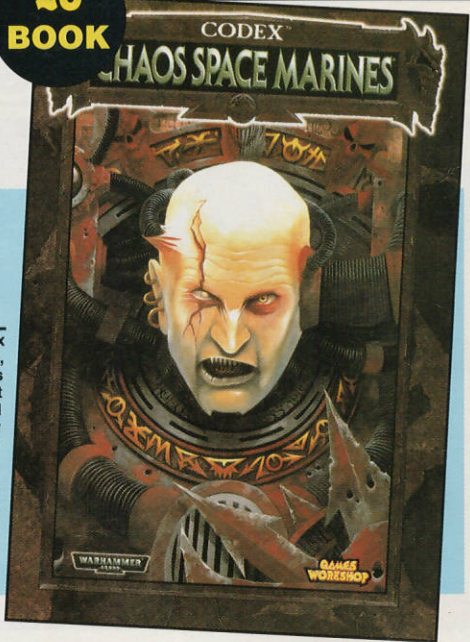

£6

Designed by Jes Goodwin

CHAOS SPACE MARINE LORD

£6

Designed by Dave Andrews

**CYPHER,
FALLEN ANGEL**

**CODEX
CHAOS
SPACE
MARINES**

This 48 page Codex contains the army list, background and rules for one of the most feared and hated fighting forces ever to threaten the Imperium.

Check out this month's battle report as the forces of Chaos battle against the Ravenwing of the Dark Angels.

**£20
Boxed set**

CHAOS PREDATOR

Designed by Mark Bedford, Norman Swales & Trish Morrison



**£10
Plastic boxed set**

KHORNE BERZERKERS

Designed by Dave Andrews



**£15
Boxed set**

CHAOS SPACE MARINE RAPTORS

Designed by Mark Bedford



**£15
Boxed set**

FABIUS BILE & BODYGUARD

Designed by Jes Goodwin & Shane Hoyle



**£5
EACH**

OBLITERATORS

Designed by Dave Andrews



**£10
Plastic boxed set**

**CHAOS
RHINO**



**CHAOS SPIKY
BITZ SPRUE**

The Chaos Spiky bitz sprues are now available separately from Mail Order. Check out 'Seriously Spiky' in this White Dwarf to see what else you can use them for...

**£2.50
EACH**

Designed by Mark Bedford
Sprues shown at approx. 30% actual size.

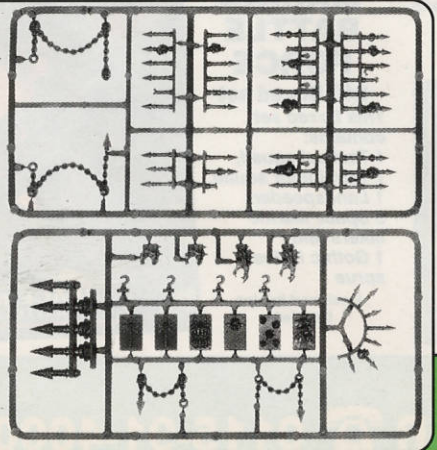

Phone 0115-91-40000 and any of these models to your collection

ADVANCE ORDER
WARHAMMER ARMIES
VAMPIRE COUNTS
RING FOR DETAILS

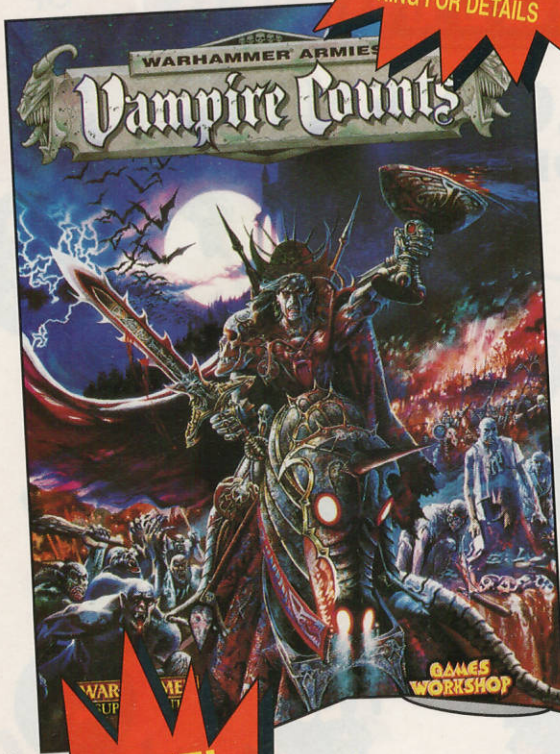

ADVANCE ORDER

Did you know...

that you can place an Advance Order for all new games and miniatures, then have them delivered to your door by First Class post, sent on the day of release!

For more details give us a call!

ADVANCE ORDER
ORK
PIRATE
SHIPS
RING FOR DETAILS



FREE!

**UNDEAD
T-SHIRT**

FOR THE FIRST 200 TO
ADVANCE ORDER
VAMPIRE COUNTS
RING FOR DETAILS



ADVANCE ORDER
DARK ELДАР
RAVAGER
RING FOR DETAILS



Designed by Tim Adcock & Gary Morley

MAIL ORDER ☎ 0115-91-40000 MAIL ORDER ☎ 0115-91-40000

£15
BOOK



DOGS OF WAR

This 96 page Armies book contains the background and rules for fifteen of the most famous mercenary Regiments of Renown in the Warhammer world.

Check out this White Dwarf for the rules for two new Regiments of Renown, the Giants of Albion and the Witch Hunters Johann van Hal & Wilhelm Hasburg, Priest of Sigmar.

WARHAMMER
REGIMENTS OF RENOWN

DOGS OF WAR
FOR HIRE

£15
Boxed set or
£3 each

£13
Boxed set or
£1.25 each



Lumpin Croop's Fighting Cocks
Full rules in WD230. Designed by Colin Dixon.



Oglab Khan's Wolfboyz
Full rules in WD231. Designed by Michael Perry.

£20
Boxed set or
£4 each



Tichi-Huichi's Cold One Raiders
Full rules in WD232. Designed by Alan Perry & Trish Morrison.

£6



Ghazak Khan
Full rules in WD231. Designed by Michael Perry.

£3



Wilhelm Hasburg

Full rules in this White Dwarf. Designed by Paul Muller.

£3



Johann van Hal

NEW



Hengus the Druid & the Giants of Albion
Full rules in this White Dwarf. Designed by Trish Morrison.

£25
Boxed set

REGIMENTS OF RENOWN!

- Pikemen of the Alcatani Fellowship**
£1.75 each, £5 for 3 or £20 boxed set of 12 pikemen including standard, musician & Captain Rodrigo.
- Marksmen of Miragliano**
£1.75 each, £5 for 3 or £10 boxed set of 6 marksmen including standard, musician & Captain Maximilian.
- Pikemen of the Leopard Company**
£1.75 each, £5 for 3 or £20 boxed set of 12 pikemen including standard, musician & Captain Leopoldo.
- Pikemen of the Republican Guard**
£1.75 each, £5 for 3 or £20 boxed set of 12 pikemen including standard, musician & Captain Ricco.
- Pirazzo's Lost Legion**
£1.75 each, £5 for 3 or £20 boxed set of 12 Legion troopers including standard, musician & Captain Pirazzo.
- Braganza's Bestegers**
£1.75 each, £5 for 3 or £10 boxed set of 6 Bestegers including standard, musician & Captain Luka Braganza.
- Bronzino's Battery of Galloper Guns**
Galloper Gun & 3 crew for £10 or £13 boxed set of 1 Galloper Gun with 3 crew & Captain Bronzino.
- The Bearmen of Urslo**
£1.75 each, £5 for 3 or £13 boxed set of 8 Bearmen including standard, musician & Beorg Bearstruck.
- Long Drong's Slayer Pirates**
£1.75 each, £5 for 3 or £13 boxed set of 8 Slayer Pirates & Captain Long Drong.
- The Birdmen of Catrazza**
£4 each or £20 boxed set of 5 Birdmen including Captain Daddallo.
- Golgfags Ogres**
£7 each or £28 boxed set of 5 Ogres including standard, musician & Golgfag.
- Voland's Venators**
£4 each, or £20 boxed set of 5 Venators including standard, musician & Captain Voland.
- Al Muktar's Desert Dogs**
£4 each, or £20 boxed set of 5 Desert Dogs including standard, musician & Captain Al Muktar.
- Asarnil the Dragonlord**
£22 boxed set includes Asarnil & Deathfang the Dragon.

ORDER ☎ 0115-91-40000 M

ORDER ☎ 0115-91-40000 M



£1.25 EACH



£1.25 EACH



£1.25 EACH

Skavenslaves Designed by Colin Dixon



£4 EACH

Skaven Warlock
Designed by Colin Dixon



£6 EACH

Skaven Warlord
Designed by Colin Dixon



£20 Boxed set

Skaven Doombeel
Designed by Jes Goodwin & Norman Swales



£20 Boxed set

Skaven Screaming Bell
Designed by Jes Goodwin & Norman Swales

SKAVEN

This 96 page Armies book contains the background and rules for the Skaven, a seething horde of vicious rat-men that lie waiting to bring the final apocalypse and overcome the Old World.

In this month's battle report, the Skaven horde of Warlord Gareth Hamilton takes on the proud and stubborn Dwarf army of Mike Walker.

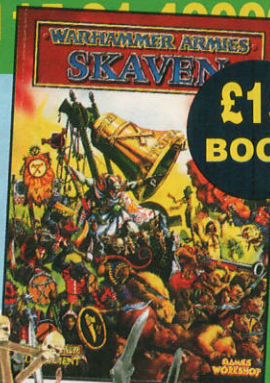

£15 BOOK



£10 Plastic boxed set

Skaven Clanrats Warhammer Regiment

Designed by Colin Dixon, Trish Morrison & Aly Morrison.

This box set contains 20 plastic, multi-part Skaven Clanrats, plus metal parts to make a champion, musician and standard bearer.

These plastic Clanrats are part of Gareth Hamilton's massive Skaven army and have had their plastic shields swapped for the NEW metal Skaven shields.



Clanrat with NEW metal shield



METAL SKAVEN SHIELDS
75p for 3



Skaven Warfire Thrower Team

Designed by Colin Dixon

£6 EACH

Skaven Jezzail Team
Designed by Colin Dixon



£6 EACH

TROLL 18

MAIL ORDER DWARF LEGENDS



Steve Weaver

Check out Steve Weaver's (he's a Mail Order Phone Troll) Dwarf Goblobber below. This great model and the rest of his Dwarf army, which includes many more Dwarf Legends, is featured in this month's Troll.

The Dwarf Goblobber is just one example of the Dwarf range that is available from Mail Order. Call now to find out more.



£20

Dwarf Goblobber - Big Stone Thrower
Designed by Michael & Alan Perry.

This month's issue of Troll, Mail Order's own magazine, is full to the brim with deals and crazy ideas, including...

- Dark Angels battle report special!
- Steve Weaver's Dwarf Legends army
- Sneaky Skaven bitz!
- Out of the Crypt! Vampire Counts advance order
- and much more...



To find out how to get your hands on a copy of Troll, give Mail Order a call.

MAIL ORDER ☎ 0115-91-40000 MAIL ORDER ☎ 0115-91-40000

GAMES WORKSHOP® MAIL ORDER FACTS

- Did you know that Mail Order can supply any back catalogue Citadel Miniatures that you could possibly want?
- Did you know, if you order miniatures we don't currently have in stock, we'll cast them up for you?
- Did you know that post and packing in the U.K. is set at £4.00 for first class and £3.00 for second class, no matter how many miniatures you order?



ANYTHING AT ALL - GIVE US A CALL

0115 91 40000 ☎

Lines are open from 7am to Midnight seven days a week, including bank holidays.

Fax: 0115 916 8002
Post: Games Workshop Mail Order,
Willow Road, Lenton,
Nottingham, NG7 2WS

**USING MAIL ORDER IS AS EASY
AS FALLING OFF A LOG!**

If you have access to a credit/debit card (either Access, Mastercard, Visa or Switch) then you can place your order by phone... Just ring the number above and the Troll on the other end will be only too happy to help you out. If you don't have access to one of the above cards, don't despair. Simply write out your order on the Order form and send it with a cheque or postal order made out to Games Workshop Ltd, to the address on the left. Still stumped? Well then, pick up the phone and give the Mail Order Trollz a call. We're never too busy to help!



Deutsch/Holland Mail Order



DIESE LEITUNG IST MONTAG BIS FREITAG VON
12 BIS 20 UHR OFFEN (Mez)
0044 115 916 8256

GEOPEND VAN MAANDAG TOT VRIJDAG VAN
12:00 TOT 20.00 UUR Nederlandse tijd
0044 115 916 8255



SUBSCRIPTIONS

Games Workshop's action comic, featuring stories about all your favourite Warhammer armies.

Subscribe to Warhammer Monthly now and not only do you get 12 issues for £22 plus P&P but you also get to choose three free gifts from the list below. That could get you goodies worth £36, absolutely **FREE!**

- IDOL OF GORK WHFB CAMPAIGN PACK
- CITADEL PAINT GRAB BAG (at least 6 assorted old style pots)
- BATTLES IN THE UNDERHIVE FOR NECROMUNDA
- 4 PACKS OF AWESOME COMBAT CARDS
- MONSTROUS FULL COLOUR POSTER
- 4 BACK ISSUES OF WHITE DWARF (our choice)

Please note: if stocks of any of the above run out, we reserve the right to substitute a gift of similar value.

	12 Issues	
UK		£22
USA		\$80
EUROPE		£33
ROW		£33



SUBSCRIPTIONS

Games Workshop's indispensable fanzine, featuring gaming ideas for gamers by gamers.

With a one year subscription to the Citadel Journal you can get a £5 boxed set or the 1999 Annual free!

	6 Issues	
UK		£24
USA		\$70
AUS		\$90
GERMANY		DM 90
FRANCE		FF 330
SPAIN		8,000pts
EUROPE		£36
ROW		£36

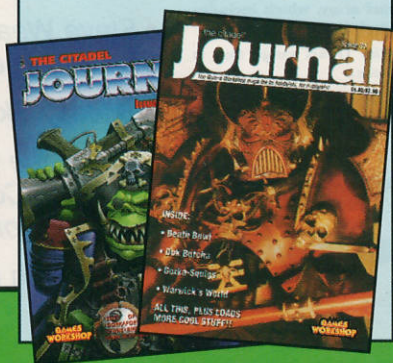

SUBSCRIPTIONS

Subscribe to Inferno!
for just £25

HERE'S THE DEAL:

- Six issues delivered direct to your door
- Two FREE back issues
- FREE UK post & packaging
- You'll save more money
- You won't miss an issue!





SUBSCRIBE

SUBSCRIBE TO *INFERNO!* FOR JUST £25 UK only

INSIDE THE LATEST INFERNO!



The latest issue of *INFERNO!* kicks off with an incredible cover from Martin Hanford. Martin has excelled himself with this film poster-style picture for *Obvious Tactics*, the long running, all-action comic strip.

Speaking of which, there's another blood-soaked episode. Our three heroes have managed to escape from the planet on board a Thunderhawk Gunship. Does this mean our intrepid heroes have made it to safety or will Antenor's rusty flying skills land them in further trouble?

I am sure all fans of Bill King will rejoice when they hear that there's another cracking Gotrek and Felix story in this *INFERNO!*

Lost for millennia in the warp, the Imperial Ship *Celestion* appears like a phantom and spells doom to any who encounter it. Find out all about this damned ship in our awesome Inquisitor's report, over eight pages of splendid illustrations from Ralph Horsley.

All this, plus more stories from Alex Hammond, Matt Farrer and Rani Kellock, and artwork from Mike Perkins, Wayne England and many more.

SUBSCRIPTION FORM

Name: Age:

Address:

.....

Postcode: Telephone no:

Please tick one

UK £25

Rest of World £38

Please choose your method of payment:

1. Cheque (payable to Games Workshop Ltd)

2. Visa Mastercard

3. Switch Issue No/Valid Date:

Card no: Expires:

Signature: Date:

Choose your two FREE back issues of *INFERNO!*

Tick two boxes only

INFERNO! Issue 4

INFERNO! Issue 5

INFERNO! Issue 6

INFERNO! Issue 7

INFERNO! Issue 8

Back issues offer is subject to availability, if your chosen issue is out of stock, we will supply another *INFERNO!* picked at random.

Return this coupon to:

Games Workshop Mail Order, Willow Road,
Lenton, Nottingham, NG7 2WS.

Or pop into your local Games Workshop store and ask about subscribing to *INFERNO!*

PLEASE TICK HERE IF YOU DO NOT WISH TO RECEIVE INFORMATION ON OTHER OFFERS.

HERE'S THE DEAL:

- Six issues delivered direct to your door
- Two FREE back issues
- FREE UK post & packaging
- You'll save more money
- You won't miss an issue!

POST THIS CARD OR CALL THE MAIL ORDER TROLLZ ON:

☎ 0115 91 40000 ☎

SHORT STORIES • ILLUSTRATIONS • COMICS AND MUCH MORE

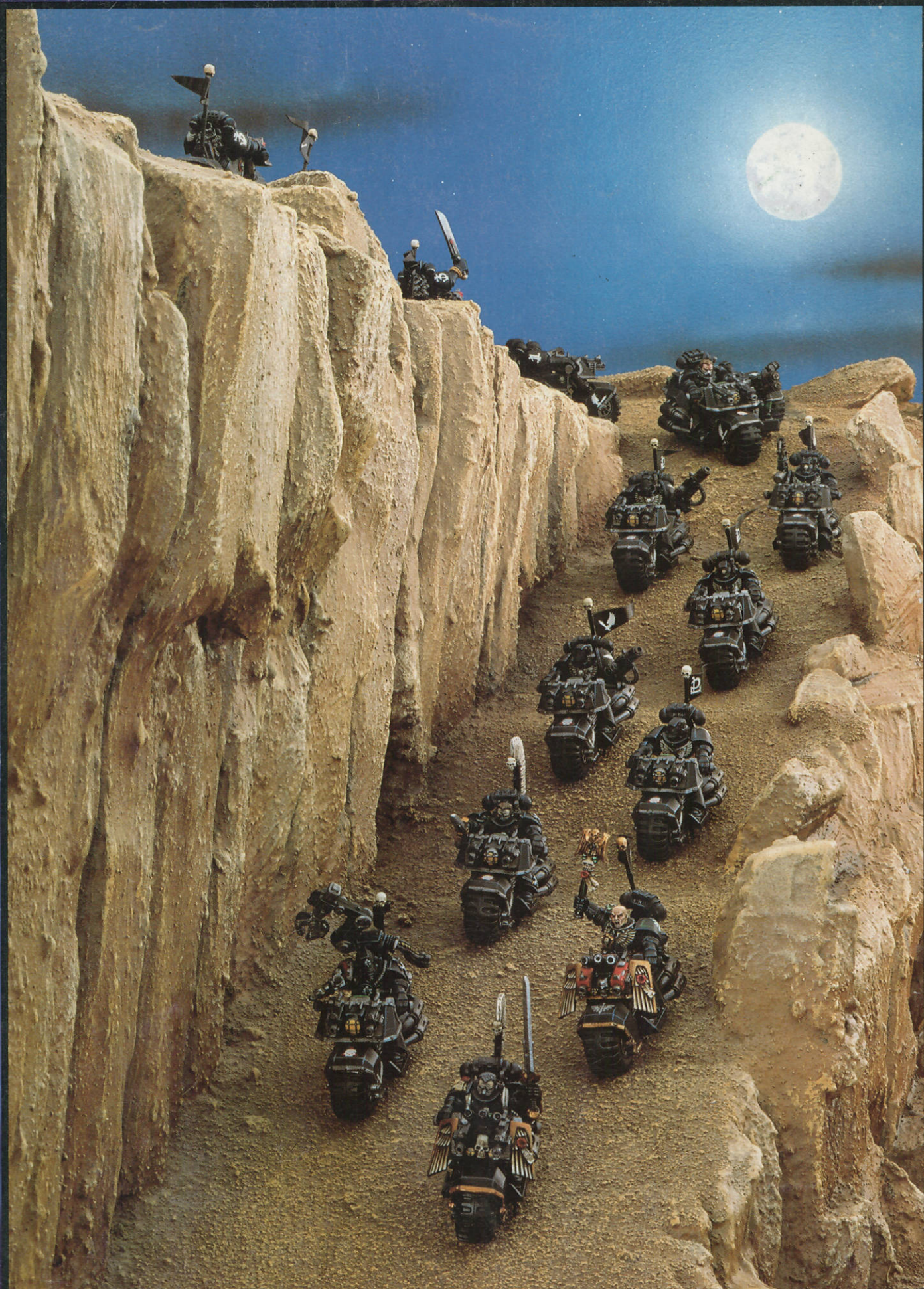

The Dark Angels Ravenwing use the cover of darkness to launch their next attack.