

GAMES WORKSHOP[®]

PRESENT THEIR MONTHLY GAMES MAGAZINE



CITADEL
MINIATURES

143
£1.95
\$3.95

WHITE DWARF





When the High Lords of the Elves first came to Ulthuan, they found that the island was already inhabited by a race even more ancient than theirs – the Dragons. In time, Elves and Dragons learned to live together, and the noblest and bravest Elves rode the Dragons into war – the Dragon Riders of legend.

Dragon Masters recreates the excitement of the struggle between the Elven Princes. Players must explore the land, raise armies and amass gold. To help them, they have a host of dragons, secretly hatched and hoarded to strike at the enemy when he least expects.

**GAMES
WORKSHOP**

Dragon Masters contains: Full-colour game board, depicting a part of the Elven Kingdoms. Plastic models representing 36 armies, 24 villages, 24 dragons, 4 cities, 4 castles, and 4 ships. Sticky-backed banner to identify each players' pieces, 64 playing cards, 54 Exploration counters. An easy-to-follow 8-page rulebook, Plus 1 six-sided die and a hoard of 64 gold pieces.



Product Code: 0958
 Ref. No: 009579
 ISSN: 0265 - 8712

Editor: Robin Dews
 Published by Games Workshop Ltd
 Printed by Artisan Press Ltd, Leicester, UK.

CORRESPONDENCE

All correspondence except subscriptions and Mail Order should be addressed to *The Editor, White Dwarf, Games Workshop, Howard House, 16 Castle Boulevard, Nottingham NG7 1FL*. Clearly mark your envelope with the name of the game you're writing to us about.

SUBSCRIPTIONS

UK and Rest of World: Please send to *White Dwarf Subscriptions, Games Workshop, Chewton Street, Hillsop, Eastwood, Nottingham NG16 3HY*. For Visa, Access and Mastercard orders, telephone our Mail Order Hotline on 0773 719213 or 0773 760462. A years subscription (12 issues) is just £20 for UK residents and £40 for the rest of the world. Postage is included in the price. Please make all payments in Pounds Sterling - make your cheque payable to *Games Workshop*.

US and CANADA: Please send to *White Dwarf Subscriptions, Games Workshop, 3431 Benson Avenue, Baltimore, Maryland 21227*. For Visa and Mastercard orders, telephone our Mail Order Hotline on (301) 644 5999. A year's subscription (12 issues) is \$35 for US residents (Maryland residents add 5% sales tax) or \$45 for Canadian residents. Postage is included in the price. Please make cheques and money orders payable to *Games Workshop*.

When you want to inform us of a change of address or subscription renewal, or if you have a query, please write to the appropriate subscription address. Make sure you tell us your name and present address (and your old address if you're moving). When you subscribe, please tell us if you're renewing an old subscription or starting a new one.

ADVERTISING

For details of advertising rates and copy dates, contact *White Dwarf Advertising, Games Workshop, Howard House, 16 Castle Boulevard, Nottingham NG7 1FL*.

The publishers of *White Dwarf* regret that they cannot accept responsibility for financial transactions between readers and advertisers. *White Dwarf* reserves the right to amend or reject any material submitted for publication as an advertisement.

GAME SUBMISSIONS

We're pleased to consider any previously unpublished articles for *White Dwarf*. All submissions should be typed, double-spaced with 30mm margins on one side of A4 paper, and should be accompanied by an explanatory covering letter and a stamped self-addressed envelope large enough to return the submission. Hand-written submissions will not be considered. Please clearly state on the envelope which game the submission is for - send to the Editor at the *White Dwarf* address.

ARTWORK SUBMISSIONS

We're happy to look at samples of black and white artwork but, in order to deal efficiently with such material, we require that all artwork be submitted as photocopies together with a stamped self-addressed envelope for us to reply and return to work. Please send all artwork submission to the Art Editor at the Design Studio address.

ALL SUBMISSIONS

Always send a copy of your submission and keep the original - *White Dwarf* cannot take any responsibility for the safety of your submissions and regretably submissions can and do get lost or damaged. Submissions not accompanied by an SASE will not be returned. Please allow at least 6-8 weeks for a reply.

RENEWABLE RESOURCES

White Dwarf is printed on paper from the Mylykoski Paper Mill, Finland. For every tree cut down, the mill plants two more. These are farmed trees grown specifically for paper so their use doesn't diminish the natural stock.

All Games Workshop's boxes, cards and counters are printed using 95% recycled paper.

All subject matter in *White Dwarf* is copyright © 1991 Games Workshop Ltd. All rights reserved.

All artwork in all Games Workshop products and the images contained therein have been produced either in house or as work for hire. The exclusive copyright on the artwork and the images it depicts is the property of Games Workshop Ltd.

Blood Bowl, Chivalry, Citadel and the *Citadel Castle, Confrontation, Dark Future, Epic, Games Workshop* and the *Games Workshop* logo, *Realm of Chaos, Taranor, White Dwarf* and the *White Dwarf* figure and *Warhammer* are registered trademarks of Games Workshop Ltd. *Adaptus Transcend, Deathwing, Dungeonsquest, Games Day, Games Workshop, Genesis, Golden Demon Awards, Kharuch, Mighty Empires, Mighty Warriors, Skatobase, Space Fleet, Space Hulk, Space Marine, 30 Roleplay Hobby Game, Titans and Ultramarine* are trademarks of Games Workshop Ltd. *Flame* is a trademark of Flame Ltd. *GW Books* is a trademark of GW Books Ltd. *Marauder* is a registered trademark of Marauder Miniatures Ltd. *Flame, GW Books* and *Marauder* are used with permission.



ISSUE 143 NOVEMBER 1991

AUDITED AT 73,134 COPIES PER MONTH

WHITE DWARF[®]

CONTENTS

COVER: BLOOD ANGEL SPACE MARINES - Dave Gallagher

GAMES WORKSHOP STORES

At your local Games Workshop Store there are always events for you to join in, whether you're a complete beginner or an old hand. Here's where to find your local Games Workshop Store in the UK, US and Canada together with a full list of store addresses and phone numbers. **2**

GAMES DAY 1991

We take a look back at the premier gaming event of the year, the finals of the National Gaming League Championships. **4**

GAMES WORKSHOP READERS POLL

Here's your chance to let us know what you think of Games Workshop and *White Dwarf* - and there are two awesome prizes for the winners of the Readers Poll Prize Draw. **6**

GAMES WORKSHOP AND CITADEL MINIATURES NEWS

Advance details about the forthcoming *Armies of the Imperium* supplement for *Space Marine* plus news from several Games Workshop stores. **11**

EPIC STOMPERS - Rick Priestley

New *Space Marine* Rules covering all the models in the new *Epic Stompers* plastic box set. **12**

'EAVY METAL 1 - Mike McVey

A selection of the latest miniatures that we've painted for our existing studio armies, including a *Blood Angels Land Speeder* and a *Squad of Striking Scorpions Eldar Aspect Warriors*. **22**

MODELLING WORKSHOP - COACHING INN AND STABLES - Rob Hooper

Complete instructions and templates for constructing a coaching inn and stables for your *Warhammer Fantasy Battle* games. **24**

MAN OF WAR - John Blanche

Exciting new concept drawings by John Blanche for Games Workshop's *Warhammer Naval Battle* game currently under development. **38**

SPACE MARINE BATTLE REPORT - Andy Chambers and Jervis Johnson

Following the release of the new, updated *Space Marine* game, the forces of the *Alaitoc Eldar Craftworld* and the *Blood Angels Space Marines* clash in *Epic* scale for a fight to the finish. Andy and Jervis have prepared a full report on this mammoth battle, including useful tactical notes and tips for *Epic* gamers. **41**

'EAVY METAL 2 - Tim Prow

More painted *Citadel* Miniatures including an *Eldar Phantom Titan*, an *Epic* scale *Eldar Avatar* and three new *Epic* scale *Eldar* attack vehicles. **60**

IMPERIAL GUARD COLOUR SCHEMES - Rick Priestley

A selection of background, rules and colour schemes for *Epic* *Imperial Guard*. **63**

BACK COVER: BRETONNIAN KNIGHTS BATTLE A HORDE OF UNDEAD

| ADVERTS | |
|--------------------------------------|--------------|
| Dragon Masters..... | Inside Front |
| D - Rok..... | 9 |
| Marauder Miniatures..... | 10 |
| Terror in the Dark..... | 21 |
| Sheffield Warhammer Day..... | 37 |
| Games Workshop Gift Vouchers..... | 37 |
| Retail Staff..... | 40 |
| Games Workshop Norwich now open..... | 40 |
| Games Workshop Towson now open..... | 62 |
| Citadel Catalogue..... | 75 |



Rick Priestley Andy Chambers Jervis Johnson Tim Prow Rob Hooper

IS
ES

GAMES WORKSHOP[®]

STORES

Games Workshop Stores are much more than just places where you buy games – they are the centre of hobby gaming in your area. There are regular special events including workshops and demonstrations of all kinds that everyone is welcome to come along to and join in with. Our friendly staff are more than happy to help you with any questions or queries you have about the Games Workshop world of hobby gaming. Drop in to or call your local Games Workshop Store for more details, plus up-to-the-minute news of any other special events.

BEGINNERS' MINIATURE PAINTING

Every Games Workshop store has an area set aside for you to learn the basic techniques for painting units of Citadel and Marauder Miniatures. We supply the paints and brushes – all you need to bring along are some miniatures to paint. If you've never painted miniatures before or you've only just started, we're happy to show you how it's done. There's always a member of the staff or a local expert painter on hand to show you what you need to know and give you useful tips and advice.

BEGINNERS' GAMING SESSIONS

Newcomers to the Games Workshop hobby are more than welcome to come along to any Games Workshop store and join in with the beginners gaming sessions. Our friendly staff will be happy to give you advice on the best way to build up your own army, explain the rules and answer any questions you might have about the Games Workshop hobby. All you have to do is drop in at your local Games Workshop store and talk to a member of staff about which games you'd like to play.



USA & CANADA RETAIL STORES



CALIFORNIA
313 SANTA MONICA BLVD
SANTA MONICA, CA 90404
MON 11.00-7.00 TUES: CLOSED
WED TO SUN 11.00-7.00
CLUB NIGHT: WED TO SUN
CONTACT: DAVE
TEL: (313) 395 6711

COLLEGE PARK
UNIVERSITY OF MARYLAND
LEHIGH ROAD
COLLEGE PARK,
MD 20740
THURS TO SAT 11.00-7.00
SUNDAY 12.00-6.00
CLUB NIGHT: FRI TO SUN
TEL: (301) 864 5668

FAIRFAX
FAIR CITY MALL
9600G MAIN STREET
FAIRFAX, VA 22031
MON TO SAT 11.00-9.00
SUNDAY: 12.00-5.00
CLUB NIGHT: EVERY NIGHT
CONTACT: OWEN
TEL: (703) 503 9284

LAUREL
LAUREL CENTER MALL, 14858
BALTIMORE-WASHINGTON BLVD
LAUREL, MD 20707
MON - SAT 10.00-9.30
SUNDAY 12.00-6.00
CLUB NIGHT: EVERY NIGHT
CONTACT: FRANK
TEL: (301) 490 8853

PHILADELPHIA
424 SOUTH STREET
PHILADELPHIA, PA 19147
MON/WED/THURS 11.00-8.00
TUESDAY: CLOSED
FRI/SAT 11.00-9.00
CLUB NIGHT: WED TO SUN
CONTACT: JEREMY
TEL: (215) 839 0554

TORONTO
331 QUEEN STREET WEST
TORONTO, ONTARIO M5V 2A4
MON TO SAT 10.00-7.00
SUNDAY: CLOSED
CLUB NIGHT: EVERY NIGHT
CONTACT: LOGAN
TEL: (416) 595-1159

VANCOUVER
205 CARRALL STREET
VANCOUVER
BRITISH COLUMBIA V6B 2J2
MON - SAT 11.00-7.00
SUNDAY 12.00-6.00
TUESDAY: CLOSED
CLUB NIGHT: EVERY NIGHT
CONTACT: GEOFF
TEL: (604) 685 8823

LONDON

BECKENHAM
292-294 HIGH ST, BECKENHAM,
KENT, BR3 1DY
CLUB NIGHT: THURS TILL 8.00
CONTACT: TONY,
TEL: 081 658 8102

CENTRAL LONDON
UNIT F10,
THE PLAZA,
116-128 OXFORD ST,
LONDON, W1R 1PA
OPEN 10.00-7.00 MON TO FRI
10.00-7.00 SAT
CLUB NIGHTS: MON TO SAT
CONTACT: LANCE,
TEL: 071 436 8839

CROYDON
UNIT35, DRUMMOND CENTRE,
KEELEY ROAD, CROYDON
CLUB NIGHT: THURS TILL 8.00
CONTACT: ED, TEL: 081 680 4600

HAMMERSMITH
1 DALLING RD, HAMMERSMITH,
LONDON, W6 6JD
CLUB NIGHT: THURS TILL 8.00
CONTACT: JOE
TEL: 081 741 3445

HARROW
296 STATION RD, HARROW,
MIDDLESEX, HA1 2DX
CLUB NIGHT: MON TILL 8.00
CONTACT: JAMIE
TEL: 081 861 2350





All UK Games Workshop stores are open from 10.00am until 6.00pm Monday to Friday and from 9.30am until 5.30pm on Saturdays unless otherwise stated.



SCOTLAND

EDINBURGH
136 HIGH ST,
EDINBURGH, EH1 1QS
OPEN SUNDAY 11.00 - 5.00
CLUB NIGHT:
THURS TILL 8.00
CONTACT: ANDY
TEL: 031 220 6540

GLASGOW
66 QUEEN ST,
GLASGOW, G1 3DS
CLUB NIGHT:
THURS TILL 8.00
CONTACT: ALISEDAIR
TEL: 041 226 3762

THE NORTH

HULL
30 PARAGON STREET, HULL
CLUB NIGHT: THURS TILL 8.00
CONTACT: ALAN
TEL: 0482 589576

LEEDS
12-16 CENTRAL RD,
LEEDS, LS1 6DE
CLUB NIGHT: WED TILL 8.00
CONTACT: TIM
TEL: 0532 420834

LIVERPOOL
47 LORD ST,
LIVERPOOL, L1 4DJ
CLUB NIGHT: THURS TILL 8.00
CONTACT: ROGER
TEL: 051 258 1404

MANCHESTER
UNIT 1, 3 BROWN ST,
MANCHESTER, M4 3AB
CLUB NIGHT: THURS TILL 8.00
CONTACT: KARL
TEL: 061 832 6663

MIDDLESBROUGH
39 DUNDAS STREET,
MIDDLESBROUGH
CLUB NIGHT: THURS TILL 8.00
CONTACT: MARK
TEL: 0642 264091

NEWCASTLE
63 CLAYTON ST,
NEWCASTLE-UPON-TYNE
CLUB NIGHT: THURS TILL 8.00
CONTACT: IAN
TEL: 091 232 2418

PRESTON
15 MILLER ARCADE,
PRESTON, PR1 2QA
CLUB NIGHT: THURS TILL 8.00
CONTACT: SPENCER
TEL: 0772 821855

SHEFFIELD
16 FITZWILLIAM GATE,
SHEFFIELD
CLUB NIGHT: THURS TILL 8.00
CONTACT: DAVE
TEL: 0742 750114

YORK
26 GOODRAMGATE,
YORK, YO1 2LG
CLUB NIGHT: FRI TILL 8.00
CONTACT: EVAN
TEL: 0904 653575

MIDLANDS

BIRMINGHAM
519 BRIDGELINK,
BULL RING CENTRE, BIRMINGHAM
OPEN 8.30-5.30 MON TO SAT
CONTACT: TED TEL: 021 632 4804

CAMBRIDGE
4 QUAYSIDE, (OFF BRIDGE STREET)
CAMBRIDGE
CLUB NIGHT: THURS TILL 8.00
CONTACT: CHRIS TEL: 0223 818350

COVENTRY
14 CITY ARCADE, COVENTRY
CLUB NIGHT: THURS TILL 8.00
CONTACT: SIUART, TEL: 0203 227311

DERBY
42 SADLER GATE, DERBY, DE1 3NL
CLUB NIGHT: THURS TILL 8.00
CONTACT: MARK TEL: 0332 371657

DUDLEY
KIOSK U, UPPER LEVEL, MERRY HILL CENTRE,
BRIERLEY HILL, DUDLEY
CLUB NIGHT: THURS TILL 8.00
OPEN 10.00 TILL 8.00 MON TO FRI
9.00 TILL 7.00 SAT
CONTACT: SIMON TEL: 0364 481818

NOTTINGHAM
34A FRIAR LANE, NOTTINGHAM, NG1 3DU
CLUB NIGHT: THURS TILL 8.00
CONTACT: CHRIS TEL: 0602 490651

THE SOUTH

BRIGHTON
7 NILE PAVILIONS, NILE ST,
BRIGHTON,
BN1 1HW
CLUB NIGHT: FRI TILL 8.00
CONTACT: CHRIS
TEL: 0273 203333

BRISTOL
13 BROAD WEIR,
BRISTOL
CLUB NIGHT: THURS TILL 8.00
CONTACT: SHANE
TEL: 0272 251533

LUTON
12 PARK ST,
LUTON, LU1 3EP
CLUB NIGHT: THURS TILL 8.00
CONTACT: JOHN
TEL: 0682 417474

MAIDSTONE
UNIT 6, 1-9 PUDDING LANE
MAIDSTONE
CLUB NIGHT: THURS TILL 8.00
CONTACT: GUY
TEL: 0822 677435

OXFORD
1A HUSH HOUSE,
NEW INN HALL STREET,
OXFORD
CLUB NIGHT: THURS TILL 8.00
CONTACT: ANDREW
TEL: 0665 242182

READING
UNIT 3, CHEAPSIDE, READING
CLUB NIGHTS: WED AND
THURS TILL 8.00
CONTACT: BOB
TEL: 0734 586693

SOUTHAMPTON
23 EAST ST,
SOUTHAMPTON, SO1 1HG
CLUB NIGHT: THURS TILL 8.00
CONTACT: REES
TEL: 0703 331962

TORQUAY
12 MARKET ST,
TORQUAY, TQ 1AQ
CLUB NIGHT:
THURS TILL 8.00
CONTACT: BOB
TEL: 0803 201036

GAMES™ '91 DAY

On Saturday 21st September the Assembly Rooms in Derby played host to the most spectacular Games Workshop gaming convention ever – The National Gaming League Finals for Warhammer Fantasy Battle, Warhammer 40,000, Space Marine, Space Hulk and Blood Bowl. From 10am the halls were packed with thousands of enthusiastic gamers, all enjoying the various Games Day events.

In the main halls the armies of the best gamers in the country battled each other across the superb specially constructed terrain to decide this year's National champions of Warhammer Fantasy Battle, Warhammer 40,000, Space Marine, Space Hulk and Blood Bowl. Heroic armies of Space Marines battled to the death on distant planets, Titans and Land Raiders crashed through futuristic cities and vast armies of Undead, Dwarfs and Elves advanced relentlessly under the watchful eye of their Generals.



Games Day 1991 – The main hall

In addition to the Gaming League Championships, Games Day was the venue for a host of tournament games, participation games, speed painting competitions and special events. It also offered gamers the opportunity to talk to all the Games Workshop writers, miniature designers, miniature painters and artists.

On the gaming tables, Andy McCormack led gullible adventurers up dark passageways in his splendid three-dimensional Advanced Heroquest dungeon. On the fringes of the galaxy budding Admirals manoeuvred vast fleets of ships, as the Imperium clashed with the Eldar in the Space Fleet tournament. All over the Assembly Rooms, hundreds of enthusiastic gamers, experts and novices alike, joined in

participation games of Warhammer Fantasy Battle, Warhammer 40,000, Space Marine, Space Hulk, Blood Bowl, Advanced Space Crusade, Mighty Empires and the forthcoming Warhammer Naval Game.

All the Games Workshop Design Studio staff were at hand to answer questions on Games Workshop products, explain rules, offer tips on painting miniatures and generally chat about the Games Workshop hobby. The Games Workshop, Citadel Miniatures and Marauder retail stands were busy all day with gamers eager to see all the latest releases.

As the day drew to a close the victorious Champions received their trophies in the packed main hall and everyone reflected on what had surely been the most spectacular gaming event of the year.

1991 LEAGUE CHAMPIONS

Warhammer Fantasy Battle

National Champion – Tony Evans: Middlesborough

Warhammer 40,000

National Champion – Lee Sinclair: Glasgow

Space Marine

National Champion – Stephen Gregory: Middlesborough

Space Hulk

National Champion – Paul Kieman: Coventry

Blood Bowl

National Champion – Steve Cunningham: Luton



Warhammer Fantasy Battle – League Finals

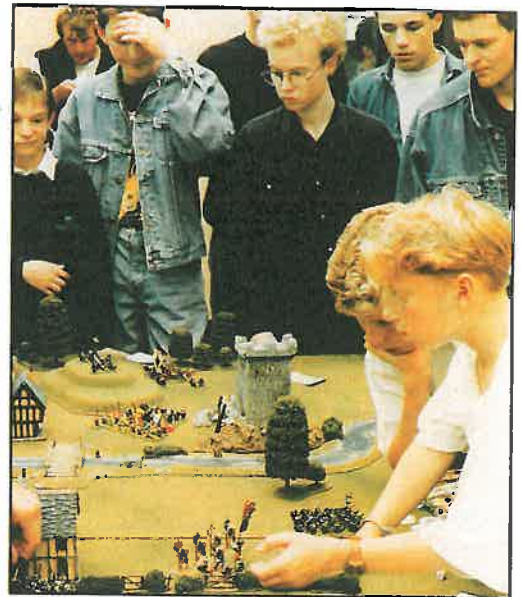

Warhammer Fantasy Battle – Participation Game



Warhammer Fantasy Battle – League Finals



Warhammer 40,000 – League Finals



Warhammer 40,000 – League Finals

GOLDEN DEMON 1992

If you missed Games Day - fear not! Games Workshop's next gaming convention, the Golden Demon Miniature Painting Championships, will be held in April next year at the Birmingham NEC! We can promise you that this will be far bigger and better than anything you've ever seen before. Watch out for more details in future editions of White Dwarf.



Space Marine – League Finals

WHITE DWARF®

READERS' SURVEY • MEGA PRIZE DRAW •

ONE OF EVERY
GAMES WORKSHOP
GAME AND BOOK
PLUS ONE OF EVERY
CITADEL MINIATURES
BOXED SET
CURRENTLY IN STOCK

PRIZE DRAW

We're offering two collections of every current Games Workshop boxed game, rulebook, game supplement, novel and artbook that we've got in stock, plus every boxed set of Citadel Miniatures currently in production – there's one prize for UK entries and one for US. We don't know exactly what will be in stock, but it'll be a huge prize!

This is our biggest competition ever, so make sure you return your completed Readers' Survey straight away for a chance to win the prize of a lifetime.

ENTERING THE MEGA PRIZE DRAW

To enter the Readers' Survey Prize Draw, all you have to do is return your completed questionnaire to the UK or US address on the reverse of the sheet – the postage is prepaid, so you don't even have to use a stamp!

All the questionnaires that we receive by the closing date will automatically be entered into the Mega Prize Draw.

CLOSING DATES

| | |
|---------------|--------------------|
| UK entries | 30th November 1991 |
| US entries | 31st December 1991 |
| Rest of World | 31st December 1991 |

Only one entry per person, please.

Here's your chance to let us know what you think of our games and White Dwarf. This will enable us to find out more about you, the people involved in our hobby, and help to make sure that we're giving you exactly the games and miniatures you want.

COMPLETING THE QUESTIONNAIRE

Filling in the Readers' Survey is simplicity itself. In most cases you just have to tick one or more boxes – for each question, it'll say whether you should tick only one box or as many as apply.

Where we ask you to write something in (eg your name and address), please write clearly in **BLOCK CAPITALS**.

Remember, there are no right or wrong answers to the Survey – just answer as accurately as you can.

RETURNING THE QUESTIONNAIRE

To return the Survey, remove the page from the magazine and fold it into three with either the UK or the US address on the outside. Then glue along the flaps as directed. If you're in the UK or US, you can send it back to us completely post free – outside the UK or US, you'll have to affix stamps as usual.

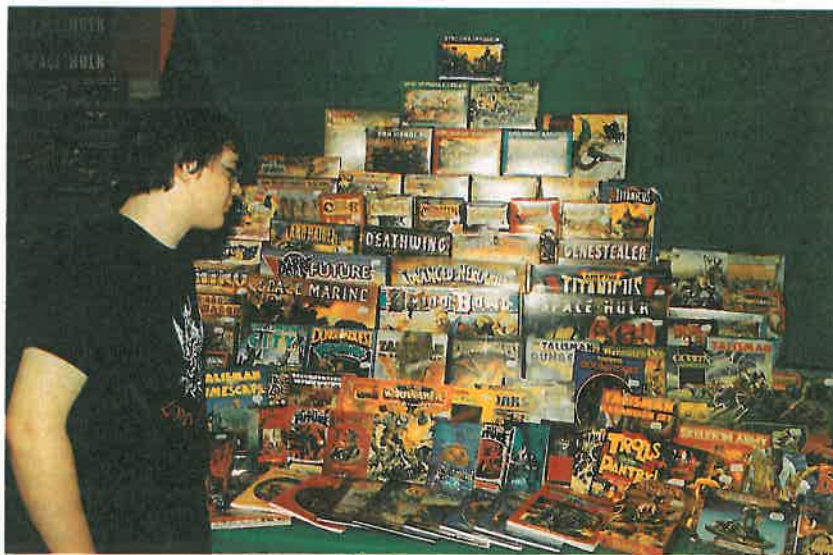

An awestruck gamer drools over the Readers' Survey Mega Prize – and this is only what we could fit onto the table!

WDE

Prize offer limited to games, books and miniature sets currently available. This competition is not open to employees of Games Workshop or their relatives. The decision of the judges is final – no correspondence will be entered into.

Please write your answers clearly in space after the question, or tick the box provided. Fill in your name and address, then remove this page from the magazine, fold as instructed on the rear, and post to the UK or US address. If you return your questionnaire before the closing date, you'll be automatically entered for the Mega Prize Draw!

Please fill in your name and address in **BLOCK CAPITALS**

NAME:

ADDRESS:

.....

..... POSTCODE/ZIP:

1. How old are you?

2. What year did you first buy Warhammer 40,000 and/or Warhammer Fantasy Battle?

3. Which of the following games do you play regularly and also collect armies for?

Warhammer Fantasy Battle

Warhammer 40,000

Space Marine (Epic)

4. How many copies of White Dwarf do you own?

5. How many other people read your copy of White Dwarf?

6. Did you respond to the last White Dwarf survey?
 YES NO

7. How often do you buy White Dwarf?
 Every issue Sometimes
 Never

8. Where do you buy most of your games and miniatures?

GW Store

GW Mail Order

Other hobby store

9. How often do you play games?

Several times a week

Several times a month

Once a month or less

10. Which of the following games do you own?

Warhammer 40,000

Epic (Space Marine)

Space Hulk

Spacefleet

Warhammer Fantasy Battle

Mighty Empires

WFRP

Blood Bowl

Heroquest

Advanced Heroquest

Space Crusade

Advanced Space Crusade

Talisman

Dungeonquest

11. Would you like to see less, about the same amount, or more of the following White Dwarf features? (Please tick only one box for each feature).

| | Less | Same | More |
|--------------------------|--------------------------|--------------------------|--------------------------|
| 'Eavy Metal | <input type="checkbox"/> | <input type="checkbox"/> | <input type="checkbox"/> |
| Army Lists | <input type="checkbox"/> | <input type="checkbox"/> | <input type="checkbox"/> |
| New game rules | <input type="checkbox"/> | <input type="checkbox"/> | <input type="checkbox"/> |
| Scenarios/missions | <input type="checkbox"/> | <input type="checkbox"/> | <input type="checkbox"/> |
| Painting guides | <input type="checkbox"/> | <input type="checkbox"/> | <input type="checkbox"/> |
| Citadel Catalogue sheets | <input type="checkbox"/> | <input type="checkbox"/> | <input type="checkbox"/> |
| Colour schemes | <input type="checkbox"/> | <input type="checkbox"/> | <input type="checkbox"/> |
| Modelling Workshop | <input type="checkbox"/> | <input type="checkbox"/> | <input type="checkbox"/> |
| Battle reports | <input type="checkbox"/> | <input type="checkbox"/> | <input type="checkbox"/> |
| Sample armies | <input type="checkbox"/> | <input type="checkbox"/> | <input type="checkbox"/> |

Postage will
be paid by
Licensee

Do not affix Postage Stamps if posted
in Gt Britain, Channel Islands, N Ireland
or the Isle of Man

BUSINESS REPLY SERVICE

License no: NW3673

READERS' SURVEY

**GAMES WORKSHOP LTD
CHEWTON STREET
HILLTOP
EASTWOOD
NOTTS NG16 3HY
ENGLAND**

2

INSTRUCTIONS

1. Remove page from magazine.
2. Trim round outer black lines, leaving flaps 1 and 2 intact.
3. Fold into three along inner black lines, leaving UK or USA address visible on the outside of the envelope.
4. Stick down Tab 1 (UK) or Tab 2 (US) to form the envelope. Please use glue or sticky tape to secure envelope. Do not use staples, as stapled envelopes will not go through our automatic opening machine.
5. If posting within the UK or US, send post free. If posting outside the UK or US, you can still participate in our survey, but you must pay the postage, so please fix a stamp to the required value before posting.



**NO POSTAGE
NECESSARY
IF MAILED
IN THE
UNITED STATES**

BUSINESS REPLY MAIL

FIRST CLASS PERMIT NO 333 BALTIMORE MD 21277

POSTAGE PAID BY THE ADDRESSEE

READERS' SURVEY

**GAMES WORKSHOP INC
3431-C BENSON AVENUE
BALTIMORE MD 21227 - 1072
USA**



D-ROK

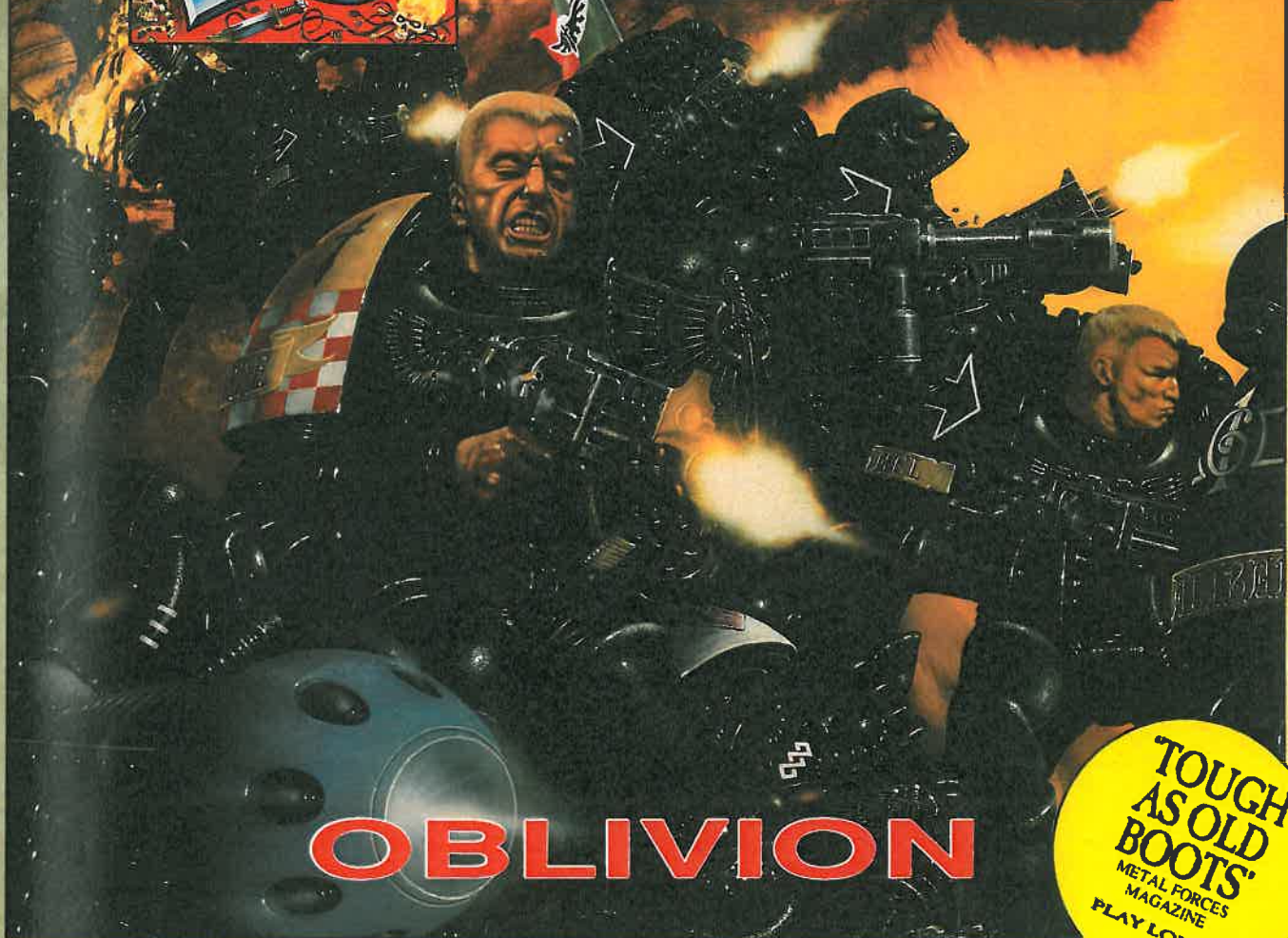

**TOUGH
AS OLD
BOOTS'**
METAL FORCES
MAGAZINE
PLAY LOUD!

D-ROK



GET OUT OF MY WAY



OBLIVION - The Album

OBLIVION is the first album on the **WARHAMMER** record label - driving, aggressive British Rock featuring Si from the Batfish Boys and The March Violets in his new band **D-ROK**.

"It's a hard hitting, strict and precise Metal/Rock album with a distinctive British Sound. With the current mixing of styles, basic Metal is becoming harder and harder to find; if you feel you've been starved, then this should fill you right up" - **METAL HAMMER**

GET OUT OF MY WAY - The Single

"Listen to the Leaden Power of **GET OUT OF MY WAY**" - **METAL FORCES**

OBLIVION is available from the end of October on all formats, and the single **GET OUT OF MY WAY** is available on 12" vinyl and CD formats.

OUT NOW!

MM16 DWARF HAMMERERS



A

B

C

D



MM16
DWARF
HAMMERERS

£3.99
FOR ANY 4

MB14
TREEMAN
£7.99 EACH



MB14 TREEMAN

ACTUAL SIZE

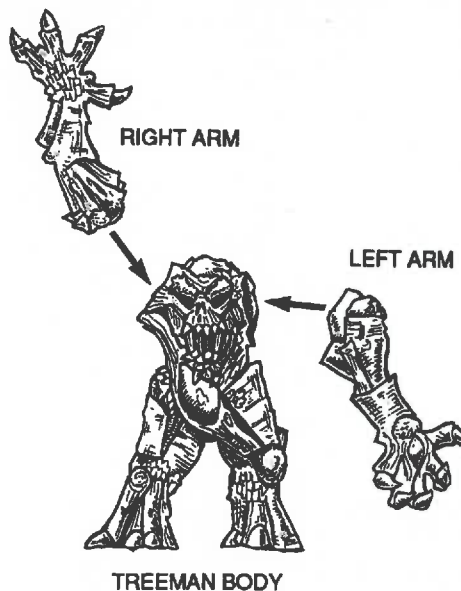

RIGHT ARM

LEFT ARM

TREEMAN BODY

Separate pieces of the Marauder Treeman are available from Mail Order. Prices are as follows:

Bodies £5.00 each
Arms £1.75 each

HOW TO PURCHASE YOUR MARAUDER MINIATURES

Marauder Miniatures are available from all Games Workshop stores, where you can choose your models from the wide selection in stock. Miniatures are also available from the Marauder Mail Order Service.

METHODS OF PAYMENT

You can mail order by credit card (Access or Visa), international money order or cheque drawn on a British bank. For foreign orders, please send all payments in pounds sterling. Cheques should be payable to Marauder Miniatures Limited. UK customers please do not send cash.

POSTAGE AND PACKING

The minimum mail order is for £5 with a standard charge of £1 for postage and packaging. Mail orders in the UK over £20 are post and packing free.

You should normally receive your order within 10 days but please allow up to 28 days for delivery.

TELEPHONE ORDERS

You can telephone an Access or Visa order on 0602 790200 between

9am and 5pm weekdays. Please have the cardholder present to authorise the transaction.

If you have any problems please contact us on the above number.

OVERSEAS ORDERS

The minimum mail order is £10. Please include 40% for post and packaging. We will send your order by the fastest route that the post paid allows. Please do not send currency as payment.

POST YOUR MAIL ORDERS TO

Marauder Miniatures
The Foundry
Mount Street, New Basford,
Nottingham NG7 7HX

GAMES[®] WORKSHOP[®] AND CITADEL[®] NEWS

ARMIES OF THE IMPERIUM

The first Space Marine supplement is currently being worked on at the studio, so look out for it hitting the shops soon. There will be more news and selected extracts in the next White Dwarf.

Armies of the Imperium covers Space Marine and Imperial Guard armies with new rules for all the vehicles and troop types available to these forces, plus army list cards to allow you to build combined armies.

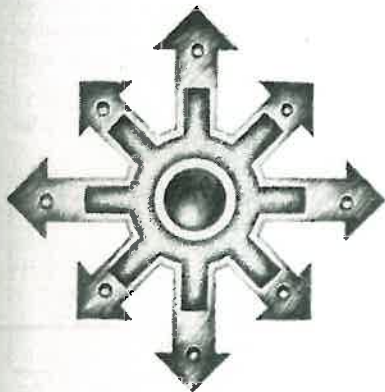

GAMES WORKSHOP OXFORD 24 HOUR BATTLE

From 4pm on Friday 2nd August right through until 4pm on Saturday 3rd August, Games Workshop Oxford ran a huge Warhammer Fantasy Battle game in aid of charity. The aim was to raise as much money as possible for the John Radcliffe Childrens Ward outside play area.

The Battle was played on a table 16ft by 4ft, contained no less than 30,000 points of troops and 800 miniatures! The huge battle was covered by the local radio station and newspaper and so far £1000 has been raised. Sponsor money continues to pour in – thanks go to everyone who was involved and made it so much fun.



A small section of the 'Storm over Voltarius' game

GAMES WORKSHOP US

Games Workshop made a major splash at two of the US's biggest games conventions this summer – Origins held in Baltimore Maryland and GenCon held in Milwaukee Wisconsin. The full range of Games Workshop games and Citadel Miniatures were on display at both events and all of the Games Workshop US staff were at hand to talk to the participants and to answer any questions about the hobby.

The showpiece of both events was an amazing Warhammer 40,000 participation game called 'Storm over Voltarius' created by Chris Alvord of our Baltimore staff. Chris had modelled the ruins of the Luminous City and the underground research laboratories became a battlefield where armies from across the galaxy fought to claim the ancient artifacts hidden in the ruins.

There was a great deal of carnage and everyone had a wonderful time. The turnout for the scenario games was tremendous and our apologies must go to all of you who couldn't get into one. The scenario winners at Origins were:

Charles Morris – Space Marines
Heath Culp – Space Marines
William Van Ripper III – Black Legion
Best Painted Army:
Mike Naylor – (Squats)

At GenCon the games were won by:

George Murdaugh – Space Marines
Matt Petaskey – Space Marines
Steve Fransom – Eldar Harlequins
Todd Stucky – Terminator Marines
Best Painted Army:
Jon Logan – (Space Orks)

GAMES WORKSHOP MINIATURE PAINTERS

There are vacancies for miniature painters here at the studio. We're looking for enthusiastic Warhammer 40,000, Warhammer Fantasy Battle or Space Marine gamers with an eye for miniature painting.

If you're interested, all you've got to do is take along some of your painted miniatures to your local Games Workshop Store and have a chat with the manager.

LAST CHANCE TO MAIL ORDER

As you might expect, it's very difficult for our Mail Order staff to respond quickly to the huge number of orders we receive around the Christmas period. This yuletide rush, coupled with the inevitable Post Office delays makes it impossible for us to keep up.

So, Mail Order customers please remember, you must send in your order before the end of November, or we can't guarantee you'll receive it before Christmas.

T – SHIRT DAY

Don't forget that on the 9th of November, an amazing 10% discount will be given to anyone who turns up at any of our Stores wearing a Games Workshop T – Shirt. If you don't yet own one of these amazing T – Shirts, then now's the time to buy one!

This special offer is open to customers in the US as well as in the UK and the discount applies to any Games Workshop or Citadel Product!

SPACE MARINE™

STOMPERS!

by Rick Priestley

With the release of the new Stompers epic plastic boxed set we thought this would be the ideal opportunity to publish Space Marine rules to cover all the models in the new set. We've also included new rules for a few extra models too, such as the Wraithguard from the Eldar War Host set, Grey Knights and Terminators.

STOMPERS

When the Orks are in the throes of a mighty Waaagh-Ork all the Mekboyz band together and work like crazy to build Gargants. Some Mekboyz manage to construct huge Great Gargants, others proudly build the smaller Slasher Gargant, but many can't find the labour or materials for such large projects and have to be content with a Stompa. Stompas don't really count as Gargants because they're too small, but they embody all the virtues of a Great Gargant in miniature. Whereas a Gargant's crew might number several dozen Orks and Gretchin (plus innumerable Snotlings) a Stompa has a small crew consisting of a few brave Orks and enthusiastic Gretchin.

Because of their small size Stompas are more like vehicles than Titans, and the game rules for them reflect this. They are treated as vehicles for purposes of travelling over different sorts of terrain and they have vehicle type game data rather than Titan data sheets.

Stompas operate in Stompa Mobs and usually accompany a Warboss – one who hasn't quite managed to get his Mekboyz to build bigger Gargants. Sometimes Stompas will be built in addition to Gargants, and the lucky Warboss can include both types in his Waaa!

As Stompa Mobs embody the spirit of the Waaa-Ork, they do not have to take morale checks and cannot be routed.

| Troop Type | Move | Saving Throw | CAF | Weapons | Range | Attack Dice | Roll to Hit | Target's Save Mod. | Notes |
|------------|------|--------------|-----|------------------------|--------------|-------------|-------------|--------------------|-----------------------------------|
| Ork Stompa | 10cm | 1+ | +8 | Batlecannon Bolters | 50cm 15cm | 1 4 | 3+ 6+ | -4 0 | Stompa Mobs ignore morale checks. |



DAVE GALLAGHER

ORK DREADNOUGHTS

Orks know a good idea when they see one and the sight and sound of Space Marine Dreadnoughts striding across the battlefield with guns blazing created a lasting impression on the Ork mind. Inspired by the success of Space Marine Dreadnoughts, Ork Mekboyz set to work making their own. Though the Orks have captured the resemblance of the human Dreadnoughts, the mechanics of their machines are typically Orky.

The Ork Dreadnought is piloted by a Gretchin which has been surgically implanted into the machine by the combined efforts of a Painboy and Mekboy. Ork and Gretchin bodies are fortunately very resilient so the Gretchin usually survives the operation and wakes up to find himself with a huge metal body that's even more Orky than Orks! This is very cheering to the Gretchin who has suffered years of being beaten around the head by his superiors. Not surprisingly his new-found power tends to go to his head, so Ork Dreadnoughts are often very hard to control.

Dreadnoughts are mobile troops and move through terrain like infantry stands. See the Terrain Chart in the Space Marine rules summary sheet for details.

Unfortunately, Ork Dreadnoughts don't always do what they're told. The Gretchin inside often gets carried away with excitement or goes crazy with power, sometimes even to the extent of bossing the Orks about. To represent this, Ork Dreadnoughts are subject to the normal Ork Command Rule

which says they have to remain within 10cm of a command unit in order to receive orders. If they receive no orders then they behave erratically. Roll a D6 for the Dreadnought unit in the orders phase: on a 1-2 it has first fire orders, on a 3-4 it has advance orders, and on a 5-6 it has charge orders.



Stompers and Ork Dreadnoughts engage Androids and Chaos Dreadnoughts

| Troop Type | Move | Saving Throw | CAF | Weapons | Range | Attack Dice | Roll to Hit | Target's Save Mod. | Notes |
|-----------------|------|--------------|-----|------------|-------|-------------|-------------|--------------------|-------|
| Ork Dreadnought | 10cm | 6+ | +3 | Autocannon | 50cm | 2 | 5+ | 0 | |

CHAOS ANDROIDS

The Chaos Android is a shining skeleton of hardened plasteel. Its cunning construction is a secret known only to certain tainted Squat fabricators working in league with Chaos Renegades. Each android contains a tiny bound daemon, an animating spirit imprisoned within its plasteel shell by the conjurations of a Chaos Sorcerer. The contained daemon hates being trapped in this way and will do anything to escape, but it is bound to obey any direct order it is given. The daemon will always try to interpret any command in as perverse a way as possible in order to avoid doing what it is supposed to.

Chaos Androids are just as much daemons as robots and are therefore considered to be daemons for rules purposes, for example if attacked by a Librarian's *destroy daemon* ability. They fight as troop stands, five models to a stand, in units of four stands. To represent their determination to deliberately misinterpret orders wherever possible order counters are placed in a slightly unusual way. Once all other order

counters have been placed, including Eldar orders from a Warlock, both players roll a D6 for each Chaos Android unit on the table. The player with the highest score may place whatever order counter he wishes, so the Chaos Androids are still moved and fight under the control of their own side but must do so with the orders they have been given. This means that sometimes their orders will be inappropriate because the bound daemons have perverted the command they would normally have been given.

Daemons are horrific creatures for mortals to behold and are therefore difficult to fight in close combat. Any living enemy fighting against Chaos Androids suffers a -1 CAF penalty. This penalty does apply to vehicles whose crews are affected, but not to robots, Eldar Wraithguard and Dreadnoughts, or other daemon troops. It does apply to Space Marine Dreadnoughts whose occupants are technically alive, if only just. Note that Grey Knights are not affected by this rule as they are resistant to daemon influence.

| Troop Type | Move | Saving Throw | CAF | Weapons | Range | Attack Dice | Roll to Hit | Target's Save Mod. | Notes |
|---------------|------|--------------|-----|---------|-------|-------------|-------------|--------------------|--------------------------------------------|
| Chaos Android | 10cm | None | +4 | Lasgun | 50cm | 1 | 5+ | 0 | Roll off to place orders. Enemy -1 CAF. |

ELDAR WRAITHGUARD

To the Eldar the prospect of death represents a final horror unthinkable to a human and unimaginable to an Ork. When an Eldar dies his consciousness passes into the warp where The Enemy, Slaanesh the Bane of the Eldar and Great Power of Chaos, awaits to consume it. Every Eldar wears around his neck a small gem called a waystone, the purpose of which is to absorb its owner's consciousness should he be killed, thereby cheating Slaanesh of his quarry and saving the Eldar from a fate that is literally worse than death. Waystones are implanted into the Wraithbone skeleton of the Eldar Craftworlds, releasing the spirit of the dead Eldar into the fabric of the Eldar Craftworld itself. Waystones can also be implanted into machines, and the consciousness they contain becomes the controlling element of the machine, allowing the Eldar to live again in a new form.

The Wraithguard are robotic bodies with Eldar waystones implanted inside them. They can move and act much like living creatures, motivated by consciousness of the dead Eldar they contain. This consciousness is not quite the same as that of a living person, but more like a dream-state, perceiving things around about in a shadowy and

disconnected way. When the Eldar go to war they are frequently accompanied by the dead in the form of Wraithguards and Eldar Dreadnoughts.

Wraithguard units perceive the world in a shadowy, insubstantial way, absorbing the emotions of living Eldar around them as much as anything else. To represent this an Eldar Wraithguard unit will always remain within 10cm of a living Eldar unit where possible to do so. If they find themselves beyond this range at the start of the movement phase, perhaps because casualties or some other unforeseen event has caused them to become separated, they automatically receive charge orders and move towards the nearest living Eldar until they are within 10cm. This will prevent the Wraithguard firing that turn, and they can only enter close combat if the Eldar unit they are moving towards is engaged in close combat. Assuming the Wraithguard begin their turn within 10cm of living Eldar they automatically receive the same orders as the closest living Eldar unit. If the closest unit is a Warlock any order can be placed. This represents the Wraithguard responding to the psychic needs of the living.

| Troop Type | Move | Saving Throw | CAF | Weapons | Range | Attack Dice | Roll to Hit | Target's Save Mod. | Notes |
|-------------------|------|--------------|-----|--------------|-------|-------------|-------------|--------------------|----------------------------------|
| Eldar Wraithguard | 10cm | 6+ | +4 | Wraithcannon | 50cm | 1 | 5+ | -1 | Takes orders from nearest Eldar. |

ELDAR DREADNOUGHT

The Eldar Dreadnought is really a larger and more powerful form of Wraithguard, and is controlled by a waystone in the same way. Like the smaller Wraithguard the Dreadnought perceives its surroundings in a shadowy and disconnected way, responding to the emotional emanations of living Eldar about it. To represent this an Eldar Dreadnought unit will always stay within 10cm of a living Eldar unit where possible to do so. If they find themselves beyond this range at the start of the movement phase, perhaps because casualties or some other unforeseen event has caused them to become separated, they automatically receive charge orders and move towards the nearest living Eldar until they are within 10cm. This will prevent the Dreadnoughts firing that turn, and they can only enter close combat if the Eldar unit they are moving towards is itself engaged in close combat.

Assuming the Dreadnoughts begin their turn within 10cm of living Eldar they automatically receive the same orders as the closest living Eldar unit. If the closest unit is a Warlock, any order can be placed. This represents the Dreadnoughts responding to the psychic needs of the living.

Eldar Dreadnoughts are mobile machines and so obey the same movement restrictions and penalties as infantry. See the

Terrain Chart on the Space Marine summary sheet for details of these restrictions. Eldar Dreadnoughts can be armed with a variety of weapons but usually carry lascannons and a power fist, a combination which gives them good close combat abilities and excellent long range firepower.



Eldar forces including Wraithguard and Eldar Dreadnoughts

| Troop Type | Move | Saving Throw | CAF | Weapons | Range | Attack Dice | Roll to Hit | Target's Save Mod. | Notes |
|-------------------|------|--------------|-----|-----------|-------|-------------|-------------|--------------------|----------------------------------|
| Eldar Dreadnought | 10cm | 5+ | +2 | Lascannon | 75cm | 1 | 5+ | -2 | Takes orders from nearest Eldar. |

SHOKK ATTACK GUN

The Shokk Attack Gun is a marvellous Orky invention. Its exact workings remain a mystery even to the Mekboyz who build them, but it works none-the-less and in a particularly effective and spectacular manner. The whirling warp-spheres at the front spin round churning up the bit of space in front of the gun to create a sort of warp tunnel. The exit to the tunnel depends on where the Ork points the Shokk Attack Gun - it might be in the middle of an enemy unit, inside a tank, deep within a building, or even inside some unfortunate Terminator's armour!

You can't really be sure where the tunnel comes out until you send something down it, which is where the infamous Snotling Attack teams come in. Snotlings, the smallest and most docile of the Ork-Gretchin race, are specially trained to jump into dark holes in return for food. Their ultimate fate is to be sent enthusiastically into a warp tunnel generated by the Shokk Attack Gun, reappearing over or even inside the target.

Though Snotlings are not aggressive by nature, the journey through the warp tunnel turns them into gibbering maniacs. Half-mad with terror they suddenly appear at their target clawing and biting everything within reach, defecating uncontrollably, and screaming like frightened alley cats. This is quite disconcerting for the poor victim, especially if the deranged Snotlings suddenly appear inside an enclosed vehicle like a tank or (worst of all) down the left leg of your Terminator suit! A vehicle attacked in this way may be rendered useless while the crew disentangle themselves from frantic Snotlings, or the engines and weapons might be clogged by Snotlings caught up in the works. Exposed troops may be clawed to death, and a Terminator can suffer a terrible fate as several explosively flatulent creatures materialise inside his helmet.

The Shokk Attack Gun takes a while to generate its warp tunnel so it can only be fired if the stand has first fire orders. The weapon has an unlimited range and can be used against any target in sight. Nominate your target and roll the scatter dice and 2D6 to determine distance scattered just like a barrage.

If you roll a direct hit on the scatter dice and a double on the 2D6 then the Snotlings have not only landed on their target but many have materialised inside it as well. If this happens the target is destroyed automatically without an armour saving throw. Titans and other large fighting machines which use the Titan-style to hit diagrams and damage charts are hit once in a randomly determined location. Work out the effect by rolling on the appropriate damage chart as normal. Shields are bypassed automatically and no armour save is allowed for Titans which have been invaded by Snotlings in this way.

If you roll a direct hit on the scatter dice and any number other than a double on the 2D6 then you have hit the target area. Snotlings pop out of the air and surround the target, clinging to arms and legs, scratching, clawing and lashing out at everything close by. The number of Snotlings that make it through the warp tunnel is somewhat uncertain, and many of those who do are reduced to a helpless catatonic state. This means their effectiveness varies a great deal - from all out frenzied attack to mere inconvenience.



PAUL BONNER

The effect of the attack is worked out as a round of close combat fought immediately against the target. The 2D6 roll already rolled stands for the Snotlings' close combat score. Because doubles count as immediate destruction as described above, this score varies from 3 to 11. The target makes its normal close combat roll (2D6 + its CAF). As with all close combat, void and power shields are ineffective and armour saving throws are ignored. If the target survives the Snotling attack it cannot shoot for the remainder of that combat phase and if engaged in close combat by other enemy it counts as having fought one round already. This means that any other close combat opponent rolls an extra D6 as described in the close combat rules. If attacked by more than one Shokk Attack Gun then each subsequent Snotling attack adds +1D6 exactly like any other close combat attack.

If you roll an arrow on the scatter dice the shot has scattered in the direction shown by the distance indicated by the 2D6 roll. The Snotlings will automatically materialise around the closest target within 5cm of the indicated point and attack it as described above. The new target may be friend or foe - the Snotlings are too terrified to tell the difference any more! If there are no potential targets within 5cm then the Snotlings have nothing to attack, and take the opportunity to scurry away, crawling off to hide under rocks or in the undergrowth.

Whatever the result, Snotlings only attack for one turn and then lapse into petrified silence, run off, hide, or otherwise make themselves scarce.

| Troop Type | Move | Saving Throw | CAF | Weapons | Range | Attack Dice | Roll to Hit | Target's Save Mod. | Notes |
|------------------|------|--------------|-----|------------------|-------|-------------|-------------|--------------------|---------------|
| Shokk Attack Gun | 10cm | None | 0 | Shokk Attack Gun | | | | | Special Rules |

MOLE MORTAR

The Mole Mortar was developed by the Squats whose homeworlds are rocky and barren and where most habitations are built underground. It has a crew of two operators who can also dismantle and move the weapon if needed. The Mole Mortar fires a burrowing subterranean shell called a tunnel torpedo. This travels rapidly underground before burrowing to the surface and exploding underneath its target. This causes the ground to collapse beneath the target engulfing infantry or tanks, and sometimes trapping large heavy tanks or Titans.

Mole Mortars fire barrages, although these are underground barrages rather than conventional air-borne barrages from artillery pieces. Work out hits exactly like a normal barrage. If the target is a super-heavy tank or a Titan work out damage as normal and then (assuming the target survives) roll a further D6 to see if the target falls into the resulting crater. If you roll a 6 the target falls into the crater and is trapped. A super-heavy tank or Titan cannot move while trapped but it is able to shoot normally. It is possible to climb out of the crater by using a charge order and then rolling a 3 or more on a D6 - the tank or Titan is then free but does not move that turn. If

you wish craters can be represented using plastiscene or some other suitable modelling material.

Mole Mortars can easily be moved from place to place, and they count as infantry stands for moving over difficult terrain. They may be moved into buildings and even fired from inside if required.



Orks advance upon buildings held by Imperial forces including Mole Mortars

| Troop Type | Move | Saving Throw | CAF | Weapons | Range | Attack Dice | Roll to Hit | Target's Save Mod. | Notes |
|-------------|------|--------------|-----|-------------|-------|-----------------|-------------|--------------------|----------------|
| Mole Mortar | 5cm | None | -3 | Mole Mortar | 150cm | 1 Barrage Point | | 0 | Fires barrage. |

SPACE MARINE DREADNOUGHTS

Dreadnoughts are huge fighting machines almost three times the height of a man. Although they could be mistaken for robots or even extra-ordinarily large armoured fighting suits in fact they are quite unique. The Dreadnought's operator is not an ordinary Space Marine but one of the Old Ones - a Space Marine mortally wounded in battle many years ago. Rather than being allowed to die he has been implanted inside the Dreadnought, his nervous system connected to the machine itself. The Space Marine survives only as a tightly curled and shrivelled organic component deep inside the Dreadnought which is at once his reborn body and his tomb. Once installed, the Space Marine can never leave the Dreadnought. He loses all sensation from his body and relies completely upon the artificial senses of the machine.

Dreadnoughts are often very ancient, sometimes many thousands of years old, with memories which stretch back to the early days of the Chapter's history. They are revered by the other Space Marines not just as potent warriors but also as ageless forebears and as the living embodiments of battles fought long ago. Dreadnoughts are difficult to build and many of the secrets of their construction were lost after the Horus Heresy. There are therefore relatively few of them in each Chapter and those that survive are carefully maintained and repaired when necessary. If a Dreadnought's occupant is killed in action then the Dreadnought is refurbished and prepared for another Space Marine.

Dreadnoughts are mobile troops and move through terrain like infantry stands. See the Terrain Chart in the Space Marine rules summary sheet for details. Dreadnoughts can be armed with a variety of weapons such as auto-cannons, chainsaws, heavy bolters, and many more. They are especially powerful hand-to-hand fighters.



Space Marine Dreadnoughts and Grey Knights spearhead the attack

| Troop Type | Move | Saving Throw | CAF | Weapons | Range | Attack Dice | Roll to Hit | Target's Save Mod. | Notes |
|-------------|------|--------------|-----|------------|-------|-------------|-------------|--------------------|-------|
| Dreadnought | 10cm | 5+ | +2 | Autocannon | 75cm | 1 | 5+ | 0 | |

GREY KNIGHTS

The Grey Knights are the most extraordinary Space Marine Chapter of all. Their secret headquarters is believed to be situated on an outer planet of the solar system, possibly Titan, but only the Inquisition knows its whereabouts for certain. The Grey Knights are daemon-hunters, recruited because of their latent psychic talents or extreme psychic resistance, and their role is to provide the Inquisition with a potent fighting arm anywhere in the galaxy.

The very existence of daemons and the Chaos Powers is not widely acknowledged outside the Inquisition, as to do so could cause universal fear and terror that would serve the purposes of Chaos only too well. Combat troops are generally kept away from daemonic forces, as few men who encounter these horrors face-to-face survive with their sanity intact. Ordinary Space Marines are too valuable to expose to such horror, although for those unfortunate enough to do so there is the prospect of selective memory removing surgery to ease the pain. Grey Knights are made of tougher stuff; men whose natural resistance protects them from daemonic presence or whose own psychic powers enable them to fight back.

Grey Knights are only deployed against daemonic forces as they are too valuable to throw away against conventional foes. They wear Terminator armour and carry a variety of close combat and distance weapons including psychic weapons such as force swords and the nemesis weapon. The Grey Knights have a fleet of fast warp ships and the best astro-navigators that the Inquisition can supply. When they arrive at the battle zone they use teleporters to transport down onto the surface or into the heart of enemy spacecraft.

A Grey Knight stand consists of five Terminators, and four stands make up a detachment. A Grey Knight detachment may be deployed as normal at the start of the battle or it can be teleported down during any subsequent movement phase. To teleport the detachment nominate a landing point and roll

the scatter dice. If the dice shows the teleporter is on target place one stand on the nominated point and the remaining three stands within 6cm of it. If the scatter dice indicates a scatter move the landing point 2D6cm in the direction shown and position the first stand in the place indicated, then place the remaining three stands within 6cm as before.

Grey Knights are not affected by the normal morale roll taken when daemons attack, though they are affected by other morale rolls as normal.

Grey Knights do not suffer close combat penalties for fighting against daemons. If attacked by a psychic power, such as an Eldar Warlock's psychic attack, a Weirdboy psychic bolt, or a spell from a Greater Daemon, then a Grey Knight stand has a psychic saving throw to represent its psychic resilience. Roll a D6, and on the score of a 4, 5 or 6 the stand is unaffected.

Grey Knights wear Terminator armour which is incredibly thick as well as affording a reasonable degree of mobility. This combines the two advantages of infantry and vehicles, and makes Terminators relatively difficult targets. At long range they are quite small and easily concealed behind localised cover or folds in the ground, while at short range their thick armour protects them from all but the more powerful weapons. To represent this Terminators have an armour saving throw of 6 on a D6 - almost all other infantry stands have no saving throw. Furthermore, because part of their save represents their small size and ability to move quickly, the save never drops below 6 - even if hit by a Volcano Cannon, Tempest Laser or other powerful weapon.

| Troop Type | Move | Saving Throw | CAF | Weapons | Range | Attack Dice | Roll to Hit | Target's Save Mod. | Notes |
|-------------|------|--------------|-----|---------|-------|-------------|-------------|--------------------|---------------------|
| Grey Knight | 10cm | 6+ | +6 | Various | 35cm | 2 | 4+ | -1 | Psychic save of 4+. |

CHAOS DREADNOUGHTS

A great Chaos Space Marine Champion may be fortunate enough to find himself implanted into a Dreadnought rather than die of his wounds. Just as Space Marine Dreadnoughts combine the barely alive remnants of a Space Marine with a complex metal fighting machine, so the Chaos Dreadnought uses sophisticated technology to prolong the lives of Chaos Champions in machine form.

The Chaos Dreadnoughts derive from the ancient time before the Horus Heresy, but since then have been rebuilt, often to mimic the form of some daemonic creature. Relatively few

survive and they are carefully maintained and repaired when necessary. If a Dreadnought's occupant is killed in action then the Dreadnought is refurbished and prepared for another occupant.

Chaos Dreadnoughts are mobile machines and have the same movement restrictions and penalties as infantry stands. See the Terrain Chart on the Space Marine summary sheet for details of these restrictions. Dreadnoughts can be armed with a variety of heavy weapons such as auto-cannons, chainsaws, heavy bolters, and many more.

| Troop Type | Move | Saving Throw | CAF | Weapons | Range | Attack Dice | Roll to Hit | Target's Save Mod. | Notes |
|-------------------|------|--------------|-----|---------|-------|-------------|-------------|--------------------|-------|
| Chaos Dreadnought | 10cm | 5+ | +1 | Various | 50cm | 2 | 5+ | 0 | |

SPACE MARINE DATA CARDS

To accompany the new rules for the Stompers we've designed the following Epic Army cards. They are based on the ones we are using in our own games, but we haven't finalised all the details yet, so why not try them and see how they work out. All comments are welcome: do you find the points values too high or too low, are the units too powerful or too weak? Why not write to us and tell us what you think. Although we can't reply to your letters individually, we do read and appreciate them none the less.

SPECIAL CARD

ORK WARBOSS AND STOMPERS

The Ork Warboss is a mighty leader of the Clans – a Boss Ork commanding many warriors and machines. The Warboss and his bodyguard are represented by a single unit consisting of a Warboss and 5 Nobz with 2 Battlewagons. The Warboss also has three Stompers to prove his might and dismay his enemies.

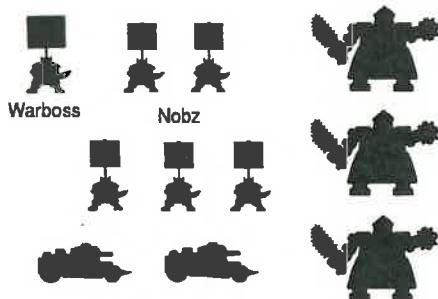

POINTS VALUE 500

ORK WARBOSS AND STOMPERS

The Warboss and his Nobz form a single command unit and never check morale if broken. Ork units can only be given orders if there is a command unit within 10cm. The Warboss is therefore an especially valuable unit as he can move where he is needed to shout orders to the troops. The Stompers form a separate Mob of 3 models. They do not require morale tests and cannot be routed. The Stomper Mob is not a command unit.

BREAK POINT 6: The Warboss and Stompers are broken once they have lost 6 models, either the Warboss, Nobz, Battlewagons or Stompers. As a command unit the Warboss does not take a morale check.



VICTORY POINTS 5

Your opponent gains 5 VP when the Warboss is broken.

ORK DREADNOUGHT MOB

The Ork Dreadnought Mob consists of four Ork Dreadnoughts.



POINTS VALUE 100

ORK DREADNOUGHT MOB

The Dreadnought Mob fights as a separate Mob within an Ork Clan in a similar way to the Snakebite Boarboyz. It can be added to any Clan to increase its fighting strength. You may add up to 2 Mobs into a Bad Moon Clan but only 1 into any other Clan. For each Dreadnought Mob added the Clan's break point goes up by +2 and the VP awarded to your opponent for breaking the Clan goes up by +1.

VICTORY POINTS ADDS +1

To make up your data cards, first photocopy the cards on this page. Fold each card along the dotted line and glue the two halves together on the inside. You can then use these cards as normal in your Space Marine games.

CHAOS ANDROID SQUAD

A Chaos Android Squad consists of four Chaos Android stands.



POINTS VALUE 100

CHAOS ANDROID SQUAD

BREAK POINT 2: The Squad is broken once it has lost 2 models. When it is broken, it must take a morale check.

MORALE VALUE 2: Chaos Androids must roll 2 or more on a D6 to pass their morale check.

VICTORY POINTS 1

Your opponent gains 1 VP when the Squad is broken.

ELDAR WRAITHGUARD HOST

An Eldar Wraithguard Host consists of four Wraithguard stands.



POINTS VALUE 100

ELDAR WRAITHGUARD HOST

Wraithguard cannot be broken and don't need to take morale checks. Victory points are awarded when the Host is destroyed.

VICTORY POINTS 1

Your opponent gains 1 VP when the Host is destroyed.

ELDAR DREADNOUGHT HOST

An Eldar Dreadnought Host consists of four Eldar Dreadnoughts.



POINTS VALUE 150

ELDAR DREADNOUGHT HOST

Eldar Dreadnoughts cannot be broken and don't need to take a morale check. Victory points are awarded when the Host is destroyed.

VICTORY POINTS 2

Your opponent gains 2 VPs when the Host is destroyed.

ORK SHOKK ATTACK GUN TEAM

An Ork Shokk Attack Gun Team consists of four Ork Shokk Attack Guns.



POINTS VALUE 100

ORK SHOKK ATTACK GUN TEAM

The plan is to fit these in as support cards, for the "coming soon" Mekboy models. Meanwhile, we suggest you add them as new units to your Clans.

BREAK POINT +2: Adds 2 to the Clan's Break Point.

VICTORY POINTS +1: Adds 1 to VP when the Clan is broken.

VICTORY POINTS ADDS +1

MOLE MORTAR BATTERY

An Imperial Guard Mole Mortar Battery consists of three Mole Mortars.



POINTS VALUE 100

MOLE MORTAR BATTERY

BREAK POINT 2: The Battery is broken once it has lost 2 models. Once broken, it must take a morale check.

MORALE VALUE 4: Imperial Guard must roll 4 or more on a D6 to pass their morale check.

VICTORY POINTS 1

Your opponent gains 1 VP when the Battery is broken.

SPACE MARINE DREADNOUGHT SQUADRON

A Space Marine Dreadnought Squadron consists of four Dreadnoughts.



POINTS VALUE 150

SPACE MARINE DREADNOUGHT SQUADRON

BREAK POINT 2: The Squadron is broken once it has lost 2 models. Once broken, it must take a morale check.

MORALE VALUE 1: Space Marine Dreadnoughts must roll 1 or more on a D6 to pass their morale check.

VICTORY POINTS 2

Your opponent gains 2 VPs when the Squadron is broken.

SPACE MARINE GREY KNIGHT DETACHMENT

A Space Marine Grey Knight Detachment consists of four Grey Knight stands.



POINTS VALUE 400

SPACE MARINE GREY KNIGHT DETACHMENT

BREAK POINT 2: The detachment is broken once it has lost 2 models. Once broken, it must take a morale check.

MORALE VALUE 1: Grey Knights must roll 1 or more on a D6 to pass their morale check.

VICTORY POINTS 4

Your opponent gains 4 VPs when this detachment is broken.

CHAOS DREADNOUGHT SQUADRON

A Chaos Dreadnought Squadron consists of four Chaos Dreadnoughts.



POINTS VALUE 150

CHAOS DREADNOUGHT SQUADRON

BREAK POINT 2: The squadron is broken once it has lost 2 models. Once broken, it must take a morale check.

MORALE VALUE 2: Chaos Dreadnoughts must roll 2 or more on a D6 to pass their morale check.

VICTORY POINTS 2

Your opponent gains 2 VPs when the squadron is broken.

ADVANCED HEROQUEST

TERROR IN THE DARK



Terror in the Dark is the first adventure supplement for *Advanced Heroquest*. Inside the box you'll find a host of new treasures, spells and magic items as well as rules for four new types of henchmen for your heroes. For the Games Master player, there are a whole set of new and terrifying monsters, with which to ambush the heroes and drive them from your lair. In addition, the new Quest Generation System allows you to create scores of exciting adventures for both Game Masters and players alike,

while the special Lichemaster Quest provides the hardest challenge any player of *Advanced Heroquest* will have yet had to face. The Quest for the Lichemaster involves the players in a series of linked adventures to recover four ancient weapons and comes complete with six sheets of new card floorplans, player handouts and a host of new hazard counters.

**GAMES[®]
WORKSHOP**



Blood Angels Land Speeder

EASY METAL

STUDIO ARMIES

Over the last few months, we've been adding lots of new models to the Studio armies. Now that we've finished painting the rank and file (at least for the moment!) we've decided to add some special character models and equipment. Here you can see the Medic, Librarian, Chaplain and Land Speeder for our Blood Angels army shown in White Dwarf 139 plus a Striking Scorpion Eldar Aspect Warrior squad for our Alaitoc army (of issue 138)

As you can see, a great deal of time and attention to detail has been put into these special miniatures. As a starting point, the new character models for our Blood Angels Army were all painted in basic colour schemes so we could use them straight away in our battles at the Studio. When we had a little more time, we added fully detailed shading, highlighting and banners to make these Characters really stand out.



Blood Angels Librarian



Blood Angels Medic



Blood Angels Chaplain



Striking Scorpions Eldar Aspect Warriors

Land Speeder with Techmarine and Space Marine Lieutenant

The Space Marine Lieutenant's rank is shown by his yellow shoulder pads. The Techmarine displays his symbol on his right shoulder pad as well as yellow and black stripes on his leg (out of shot). The Land Speeder itself has a blue campaign badge on the near side and a white blood drop on the opposite side to show that it is from the Third Company.

Blood Angels Medic

The Medic has been painted in a combination of Skull White and Blood Angel Orange. The white armour was shaded by mixing in a tiny amount of Chaos Black and blending it into the recessed areas. We wanted to put a black keyline around a red blood drop on the medics leg to make it really stand out against the white background. To do this, we first painted a solid black blood drop. The centre of this was then painted Skull White, leaving a thin black line around the outside and finally, the white was painted over with Blood Red. The coat of Skull White makes the Blood Red much brighter than if it had been painted straight onto Chaos Black.

Blood Angels Marine Librarian

Blue is strongly associated with Marine Librarians, so we painted the top half of the miniature Moody Blue, highlighted with Enchanted blue and repeated this colour scheme on the banner. We wanted to add parchment scrolls to the purity seals on the leg. These were made of thin strips of paper and glued into place, before being painted Orc brown.

Blood Angels Chaplain

The Chaplains armour was first painted Chaos Black and then highlighted by mixing together Skull White to Chaos Black and applying this carefully to the edges of the armour plates. The piping details around the edge of the armour were first

painted Skull White and then given a coat of Blood Red. All of the bone areas on the Chaplain were given a base coat of Bleached Bone and were then highlighted with Skull White. The skull on the top of the standard is plastic, taken from the Skeleton Army box set.

The winged blood drop on the top of the Librarian and Medic banner poles were converted using the Imperial Eagle Standard (from the Space Marine backpack sprue) by cutting off the heads and tails and painting the centre section red.

Striking Scorpions

The squad of Striking Scorpions is the most recent addition to our Eldar Alaitoc Craftworld army, first shown in White Dwarf 138. These all have a relatively simple paint scheme but look outstanding as a squad because of the banner each one has been given. A mix of Yellow Ink and Sunburst Yellow was applied fairly thinly over the entire surface of the banner so that the aspect rune shows through.

Bretonnian Knights

On the back cover, you'll see our latest unit of Bretonnian Mounted Spearmen, painted by Neil McIntosh from Games Workshop Liverpool and Matthew Fletcher from Games Workshop Nottingham on their visits to the Studio. The horses were all painted different colours, but the techniques for the shading and highlighting were the same. After the base coat was dry, the highlights were gently drybrushed on in lighter shades of the base colour. To smooth out any roughness in the highlights, a thin wash of ink was applied before the reins were painted in Chaos Black. When the black was dry the reins were painted Skull White, leaving a thin line of black on the edges of the reins to make them stand out against the horse, using the same technique as we did with the Librarians blood drop. Finally, the white coat was painted over with Blood Red.



Blood Angels Librarian



Blood Angels Chaplain



Striking Scorpions



Blood Angels Medic

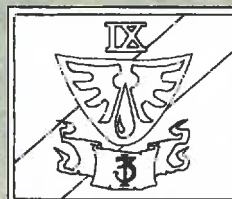

Blood Angels Land Speeder

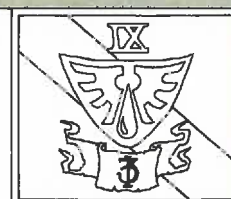

MODELLING WORKSHOP

BUILDING A COACHING INN AND STABLES FOR WARHAMMER FANTASY BATTLE

By Rob Hooper

Over the past months we've shown you how to make a variety of scenery and buildings for your Warhammer Fantasy Battle and Warhammer 40,000 games. Judging by the positive response we've had many of you have discovered how easy and rewarding modelling is.

Rob Hooper is the Manager at Games Workshop Torquay and a keen Warhammer Fantasy Battle gamer and model maker. In this article Rob takes us step-by-step through the construction of his impressive Coaching Inn and Stables. At first glance the building may appear complex, just work through the instructions and you'll find the model straightforward and rewarding to make.

If you want to have a go at adapting this model or designing your own, you can find lots of ideas for buildings together with illustrations, plans and elevations in the Warhammer Fantasy Roleplay rulebook.



EQUIPMENT AND MATERIALS

The main parts of the buildings are made from 5mm foam card, and the timber effect is achieved with various thicknesses of balsa wood: 1mm for the planks and 3mm for the timber supports. Roof tiles and other details are made from thin card, such as cereal packets, and the chimneys on the inn and the forge are made from self hardening modelling clay. The whole building is assembled with white PVA glue.

Foam card is available from most art shops or graphic suppliers and is not expensive. If you cannot obtain foam card, you can use thick card such as artist's board or even the corrugated card from cardboard boxes. However if you do use card you will need to put some reinforcement strips inside the building to make it stronger. Balsa wood is very cheap and can be found at any good model shop. If you have problems finding any of these items contact your nearest Games Workshop who will be happy to help you.

To construct the buildings you will need a sharp modelling knife, a steel ruler, some ordinary pins and a couple of cocktail sticks or sharpened matches and an area to work on. Remember to protect your working surface with a cutting mat or piece of hardboard.

CONSTRUCTING THE INN

The inn complex is designed to fit within an area 30cm square and is easiest to build in two separate sections. The first section is the inn itself and the second is the courtyard with the stable and forge.

For the base of first section, the inn, cut a rectangular piece of thick card or hardboard 11cm x 30cm. If you use thick card you may find it warps slightly when you put the paint and the glue onto it. This isn't a real problem as it can be gently bent back into the correct shape. Hardboard will not warp but is more difficult to cut in the first place. I used card for my buildings but you can use whatever you find most convenient.

Mark one long edge of the base as the front as it will become important later when trying to match the two sections together. At the same time cut a second rectangle of card or hardboard 18cm x 30cm and put this to one side to use later for the base of the courtyard

If you look at the templates for the inn you will see that there are two high end walls, two high side walls, two low end walls and two low side walls. The shape of the inn is such that the high walls make one section of the building and the low walls another. There are then two other low walls which make the middle section. The building itself is made from these three sections.

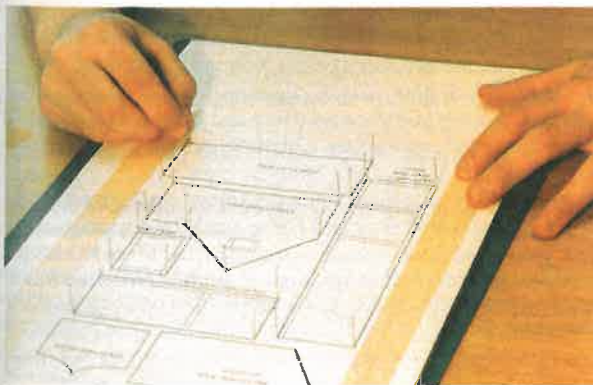

Using pins and the template to transfer the building shapes to the foam card.

TOOLS AND MATERIALS

We used the following tools and materials to make our buildings. They're all easy to buy and fairly cheap. If you have a problem finding any of these items, ask the staff at your Games Workshop store for the best place to find them locally.

Card. We used foam card for the walls. This is a foam sandwich with thin card on the outside. It's available in different thicknesses but we find that the 5mm (1/4") is the most useful and works well in almost all modelling situations. Foam card is available from art shops or graphic suppliers at around £6.00 for a sheet that's approximately 800mm x 1000mm – enough to make several buildings.

In place of foam card, you can use any stiff thickish cardboard. Thin card, like cereal packet card, is a bit too flimsy for a building like this, but if it's all you've got you could try gluing two sheets of card together to make a stiffer, thicker card.

Mounting board or thick card for the base can be bought at most art shops for around £1.50.

Balsa wood is readily available from most model shops. We used strips of approximately 1.5mm (1/16") thick balsa wood for the planking on the barn.

All-purpose glue suitable for card, plastic, balsa wood, etc.

Modelling knife with replaceable blades (remember to always work with new sharp blades, because they're much safer than blunt blades).

Packs of modelling clay can be bought in most art suppliers. Make sure you get the self-hardening variety which sets without being heated.

Steel ruler (a plastic or wooden ruler would be ruined very quickly).

Sand or flocking is easily available from DIY stores or model shops for texturing the base.

PVA glue. This is the white glue used for woodworking, available from DIY stores and hardware shops.

Masking tape or sellotape.

Emery board, fine grade sandpaper or a nail file.

Scrap pieces of balsa wood, cardboard and wheels and crates etc from your bits box.

SAFETY FIRST

It's worth reminding you that modelling tools can be dangerous if they're carelessly used. Remember that they're very sharp and they cut – and it's so much easier to make this model if you've still got fingers.

The most important safety rule is to make all cuts away from your fingers. It's much safer to cut through a sheet of card with several light strokes than with one heavy stroke. You're far more likely to slip when pressing too hard so you'll find that you actually get a much straighter cut with light strokes.

Always use a new blade. Sharp blades are a lot less dangerous than old blunt ones which you have to press very hard to cut through anything.

If you're unsure of what you're doing, then ask for some help, especially if you're a young modeller.

All Games Workshop stores are involved with terrain building, so if you need some advice or information on where to get materials, don't hesitate to drop in or give them a call – they'll be only too pleased to help.

You now need to transfer these template designs to the foam card in preparation for cutting out. Photocopy the templates and stick them onto the foam card with masking tape or small pieces of sticky tape. Take a pin and make a series of holes through the corners and angles of the templates into the foam card beneath. When you've marked all the angles, carefully remove the template to reveal a dot-to-dot copy of the building parts on the foam card beneath.

Using a pen or pencil and ruler join the dots to make an exact copy of the templates. You may find it helpful to refer back to the templates to make sure you've joined the right dots, or not accidentally missed any out! If you are not using foam card and the card you are using is thinner than 5mm, then your building will end up very slightly smaller. This is not a problem and you do not need to change the templates.



Now you can cut out the shapes using the steel ruler to make sure you get a straight line. It is important not to use a wooden or plastic ruler because you will cut into it and the cut won't be straight. Always make all cuts away from yourself. It is easier and safer to make two or three gentle cuts rather than trying to cut right through the card in one go.

Having cut the wall sections out you are now ready to start building the basic shape of the inn.

THE WALLS OF THE INN

Take the two tall side walls and the two tall end walls and glue them together using PVA glue, remembering to join them so that the side walls fit inside the end walls. Then take the two low end walls and the two low side walls and glue them together, again making sure the side walls fit inside the end walls. When this is done you will have two small buildings.

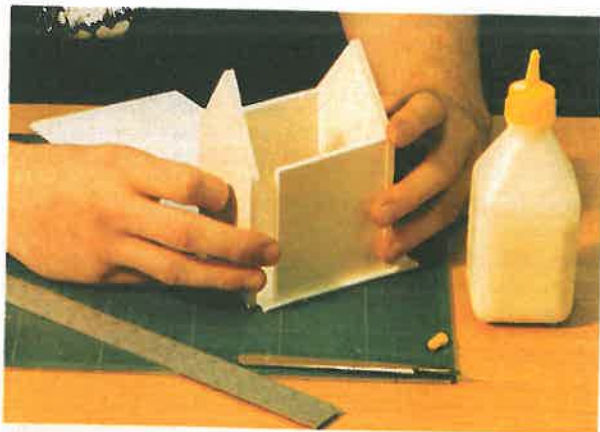

Gluing the sides of the inn together.

Take the shorter of these two buildings and glue it to the base so that it is about 5 or 6mm from the front and the same distance from the left edge. This is why you needed to know which was the front of the base. Note that the roof of this section runs from the front to the back of the building. When this has dried take the two extra low walls and glue them onto the base so that one of them lines up with the back wall of the small building and the other one joins onto the side of the small building about 30mm from its front edge. You may find it useful to refer to the plan drawing of the inn to make sure everything's in the right place.

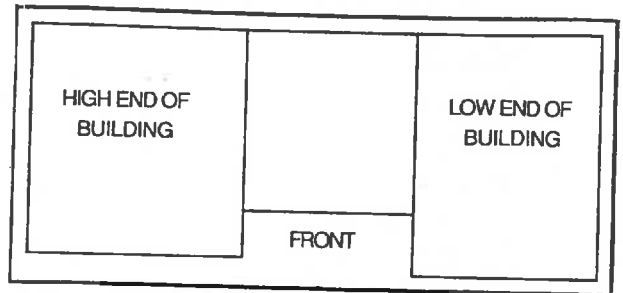

Finally, when these are dry, glue the tall building onto the base so that it joins up against the two walls. Make sure that the back wall of this building lines up with the other back walls. Note that the roof for this building runs from side to side rather than from front to back as with the other section. The basic shape of the inn is now complete.

TIMBERING THE INN

The timber effect on the building is made by gluing strips of balsa wood onto the model. Balsa is by far the best thing to use for this and you should try to get some if at all possible. It is possible to use card but because it has no grain the end result will not be as effective. When cutting balsa wood to make the various timber supports and planks you will need for these buildings it is important to remember to cut along the grain of the wood, not across it, or the wood may split and break up.

The templates for the basic wall shapes have all the positions of the timbers marked onto them for you to refer to. The first timber to fix is the 3mm square strip which runs around the entire building at ground level, allowing a gap for the large double doors to the coach house. Then fix the upper 3mm square strip which also runs around the entire building and forms the divide between the plaster and the timber areas of the building. It is a good idea to let these two strips dry thoroughly before continuing as this will make fitting the vertical timbers much easier.

The best way to fix the vertical timbers is to start at the back wall then do the two sides before attempting the front, which is the most complex part of the building. The back is the simplest because there are no doors and only one window. It consists of two end timbers with eight others evenly spaced between them. Leave the window bars and the diagonal timbers for now and move on to the side of the high building. This wall has a side door and one ground floor window on it and is formed from two end timbers with three others in between them. Note that the gap to the left of the door-frame is narrower than the one to the right. Again, leave out the door and window frame for the moment. Move now to the opposite end of the building which has the two end timbers and three others evenly spaced between them.

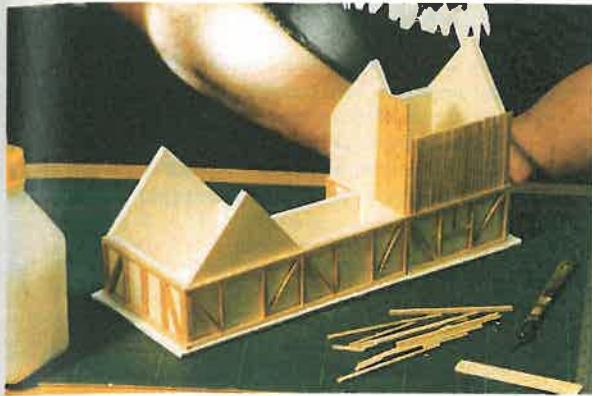

Applying the half timbering.

The front of the inn is the most complex to timber because of the doors and the shape of the front wall. First fix the vertical timbers on the front of the high building – two end timbers with two others spaced evenly between them. Then do the front of the low building which has two end timbers with three others evenly spaced between them. Leave the door and window frame for the moment.

Next fix the vertical timbers which mark the inside corners of the central section and the frames of the large double doors. When the vertical timbers have all been glued on you can go back over the building, and fix in all the diagonal support timbers and the horizontal timbers which form the bottom of the window frames, the supports for the double doors to the coach house, and the tops of the door-frames for the two small doors.

The window frames can also be fixed in now by trimming the 3mm thick balsa to about half its thickness and vertically dividing the front window into three sections and the side and rear windows into two sections.

All the doors for the building are made from thin strips of 1mm balsa cut and stuck on in a slightly haphazard way. This is more appropriate to the style of building than having them all completely straight. The diagonal support strips on the double doors are added after the other strips are completed.

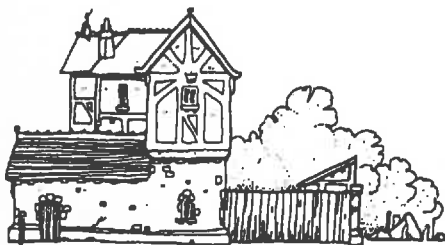

The timbering on the upper stories of the building is made in the same manner as the doors, again cutting the planks slightly haphazardly rather than all the exact same width. When timbering the end walls which form the points it is easiest to stick all the planks on first and then trim them to match the slope when they have dried.

You will notice that the front wall of the low side of the building and the side wall of the tall building both have windows. These are very simple to make by leaving a gap of the correct size in the timbering as you stick it on. When you have finished this you will have completed the walls of the inn and can begin working on the three roof sections.

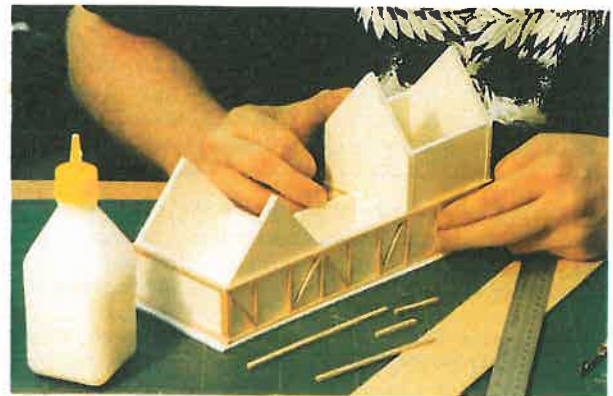

Doing the planking.

THE INN ROOF

Like the building itself, the inn roof is made in three sections, two of which join together and the other is separate. Before you begin construction it is important to decide if you want the roof of the building to lift off or not. I always construct buildings so that the roofs can be taken off, which allows me to put models inside to show the defenders. You do not have to do this but the extra effort is well worthwhile.

The roof sections are very easy to build. Mark the templates onto thick card using pins and draw the shapes in with pen and ruler. Cut them out; again remembering to cut away from your fingers! When you cut out the roof section for the low part of the building mark the lines which show where the middle section of the roof joins onto it.

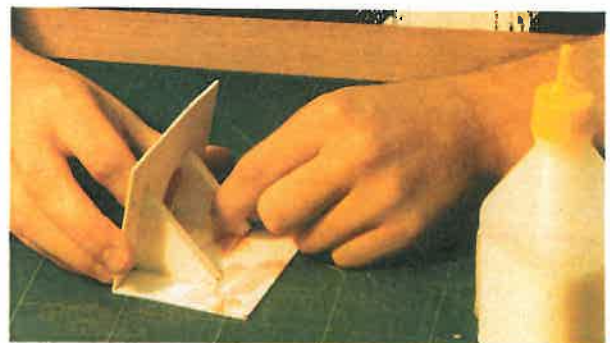

Fixing in the roof supports.

Glue the two parts of the roof for the tall section of the building together and after checking they fit properly onto the walls put them to one side. You will find it helpful to stick two brackets inside the roof to hold it together while the glue dries. This also helps make the roof stronger and ensures a better fit when it is all finished. You can make these very simply out of scraps of the foam card by copying the top 2 or 3cm of the template for the end walls. Position these brackets about 3cm from the edges. Next make the roof for the low section of the building, again putting brackets inside to strengthen it. Then make up the middle part of the roof and glue it to the position marked on the low section roof.

To finish the roof you need to stick on all the roof tiles. This is a long and time consuming task but when completed looks superb. You have to cut out individual roof tiles about 8mm x 10mm and stick them onto the roof individually. The simplest

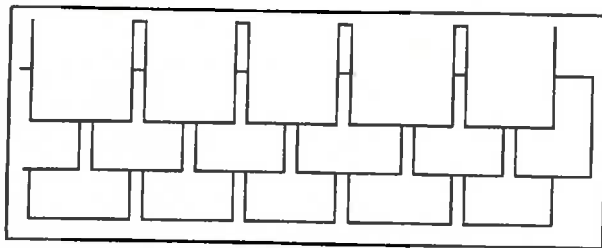

Overlapping the roof tiles.

way to make the tiles is to slice thin card into strips about 7 or 8mm wide and then chop these into 10mm or so lengths. The exact size is not too important as some variation actually suits the building better than if all the tiles were exactly the same size. Stick the tiles on starting at the bottom and working up to the ridge of the roof overlapping the tiles slightly as you work upwards. The bottom of the 2nd row of tiles should overlap the top of the 1st row, the bottom of the 3rd row should overlap the top of the 2nd row and so on up to the top of the roof.

The same procedure is used for all the roofs, though it is a little more complicated where the middle section joins the other roof as here you will need a few tiles cut into a triangle shape to match the join.

When all the tiles have been stuck on a long ridge tile can be fixed over the area where the tiles on both sides of the roofs meet so that the join is covered. Now you can check the final fit of the roof to make sure that the vertical timbering on the walls doesn't get in the way. If it does, it is easy to trim these a little so the roof sits on top neatly. If you want to glue the roof on this is the time to do it. The building is now ready for the final details prior to painting.

FINAL DETAILS

The chimney is made by cutting out and gluing together the two chimney templates. When they are dry they can be stuck onto the roof of the lower section of the building. Roll out a 1mm-thick sheet of modelling clay and wrap it around the chimney so that it is totally covered. Try not to get too much clay onto the roof if you can help it. If you find the clay does not stick a little PVA glue will help.

For the chimney pot make a small cylinder of clay about the thickness of a pencil. When the clay is nearly dry you can carve a stone pattern into it by using a cocktail stick or a sharpened match. When it is totally dry cut a length of about 6 or 7mm and glue it to the top of the chimney.

To complete the walls paint a thin coat of Tetrion or Polyfilla onto the panels to give a textured finish which can be used to hide any slight errors you may have made and to disguise where the ends of foam card shows through. This textured finish is very similar to that found on old plaster which is what we are trying to copy. Use an old size 3 or 4 brush and try not to get too much filler onto the timbers. Then texture the edges of the base by painting PVA glue around the edge of the building and while it is still wet sprinkle fine sand onto it. This will eventually be painted to represent grass or the interior of the courtyard. When this is dry the building is ready for painting.

You can now go straight onto building the courtyard if you want, or you can paint the inn so that you can use it straight away. One of the main reasons for building the model in two sections is so they can be used together or apart as you wish.



PAINTING THE INN

The inn building has a lot of wood on it which I wanted to paint in a natural brown finish, so that it looked like old weatherbeaten oak. Because of this I decided to undercoat the model in black which I think makes the shading easier. You could use slightly thinned Citadel Chaos or Salamander Black paint for this and apply it with a large brush, but it is quicker to use a black car primer spray such as you can buy from a car accessory shop. If you do use a spray remember to use it out of doors, ideally in the garden, and on a sheet of newspaper to catch any overspray. However you decide to paint the undercoat it is important to allow it to dry completely before continuing the painting.

I started by painting all the timberwork with a technique called drybrushing. This involves taking a fairly large brush, about size 3 or 4, and dipping it into the chosen paint colour so that the bottom half of the brush head picks up some paint. This is then wiped off on a tissue until the brush is nearly dry, hence the term drybrushing. Gently flick the paintbrush across the timbering so the trace of paint on the brush picks out and highlights the details of the wood grain. It is necessary to repeat this process several times using progressively lighter shades of colour until you achieve the desired effect.

I drybrushed Bestial Brown over the black undercoat to give me a brown base for the timber, which left the black showing through as the darkest grain pattern. When the brown had dried I mixed half and half Bestial Brown and Bronzed Flesh and repeated the drybrushing to give me more highlights. When this was dry I used Bronzed Flesh straight from the pot and drybrushed with that before finishing with a mix of half and half Bronzed Flesh and Skull White. When dried this gave me the old weatherbeaten colour I was looking for.

The next thing to paint is the panels on the walls themselves. It's best to drybrush the timbers first, in case you accidentally get paint on the panels. I chose a white finish for my inn although it would have looked just as good in grey or cream. To paint the panels I gave them a coat of Elf Grey first as the darkest shade. I then stippled over this with Skull White, putting more paint in the centre of the panel and fading away towards the edge to give an impression of shade.

To stipple you need a fat brush with very short hairs. Take an old size 3 or 4 brush and cut the hairs so that they are only about 6 or 7mm long. Dip the brush into the paint so that the hairs are covered and wipe off the excess paint, though it shouldn't be as dry as when drybrushing. Dab the brush against the surface so the hairs spread out around in a circle. To shade with this technique use more stipples in the centre of the panel than towards the outside edges. It is a good idea to practice this first on a scrap of card until you get the correct finish.

When the stippling is finished the basic walls of the inn are completed. Add details with a small paintbrush, repaint the inside window areas black and then draw on fine white cross lines to simulate the lead strips seen in old windows. On my inn I decided to paint in a small poster next to the door. After painting this directly on the wall I realised it would have been much easier to have drawn it on a scrap of paper, then glued it on the wall. It would also look much more like a real poster.

The roof tiles are painted a red/orange colour which is also drybrushed over a black base coat. I began by drybrushing the whole roof area with Terracotta. To save time it is best to use a very large brush, a 1/2" or 3/4" is ideal. These brushes can be bought from any decorators or DIY shop, Games Workshop shops also sell terrain painting brushes which are very good

for this. If you drybrush upwards from the bottom of the roof towards the top you will get an excellent weathered effect. After the Terracotta the next drybrushing is with Blood Angel Orange and finally with a mix of Blood Angel Orange and a little Skull White.

The chimney is touched up with black if needed before being drybrushed with a mix of Chaos Black and Skull White to make a dark grey, then finished off with a drybrush of Elf Grey. The chimney pot is painted in exactly the same way as the roof sections.

The textured areas on the edges of the base can now be painted with Woodland Green paint and drybrushed with a mix of Goblin Green and Sunburst Yellow. This applies to the rear of the inn and both sides. The front will be part of the courtyard so it should be painted with a mixture of Bestial Brown and Brown Ink and drybrushed with a mixture of Snakebite Leather and Sunburst Yellow.

The inn can now be used on your games table just as it is, however I included a few extra details to my model to really finish it off. If you look at the photograph of the finished inn you will notice that I have added an inn sign above the front door and some ivy plants growing up the walls alongside the large double doors.



The inn sign is very simple to make: cut a rectangle of paper about 15mm x 30mm and fold it in half to form a square. Glue the blunt end of a sharpened match into the fold of the paper so that it forms a sign. This can then be painted any colours or design you choose. I decided to use Sunburst Yellow with a Red Gore stripe to make a bright coloured detail. The black eagle could have been painted on but I chose to use one of the new Warhammer transfers which are ideal for this sort of detail. You get around 200 individual transfers in many different designs and colours in each pack.

The climbing ivy is made from long rolls of modelling clay which is pressed onto the walls, particularly around the corners and along the cross timbers where it would grow naturally. Be careful when sticking the clay on that you do not make it difficult to get the roof on and off. Just before the clay is dry you can then jab it with a cocktail stick or sharp match to make it look like vegetation. When it has dried paint it with Woodland Green and carefully drybrush over this with Goblin Green and a little Sunburst Yellow.

THE COURTYARD AND STABLE BLOCK

The second part of this modelling workshop deals with building the enclosed courtyard to complement and complete the coaching inn. There are two buildings within the courtyard: a stable block and a small open sided forge/smithy, both of which are straightforward to build.

CONSTRUCTING THE BUILDINGS

The courtyard is built on the 18cm x 30cm card or hardboard base which was cut out and put to one side when we began building the inn. Take this base and place it up against the front of the base of your inn so that the long edges match up. Mark an area about 8cm x 7cm in the front right corner of the base, which is where the forge will fit. Then mark a rectangle about 9cm x 14cm back from the front left corner of the base to show the position of the stables building. If you look at the photograph of the finished courtyard you will see the remaining areas are plain courtyard within a surrounding wall. The back of the base is not walled off because this is where the inn will be placed.

As with the inn building the first step in the construction is to mark the template plans for the courtyard walls and the stable building onto foam card and cut them out. Using PVA glue stick the outside end of the stable building to the base so that it is about 1 or 2mm back from the front edge and 1 or 2mm in from the left side – the extension wall has to point towards the area where the forge will be located. Next glue the outside wall on the stable so that it fits inside the end wall already stuck on. Followed this by the stable end wall and the inside wall, again making sure that the side wall fits inside the end wall.

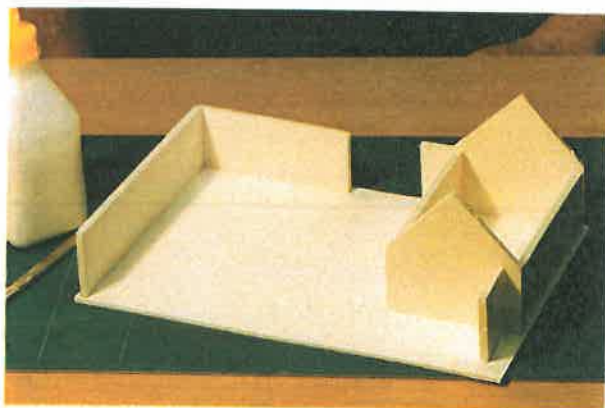

Assembling the courtyard.

When the stable building has dried place the courtyard base in position in front of the inn and mark the position of the walls onto the courtyard base. They have to be positioned so they match up to the end walls of the inn. This sounds complicated but you can see from the photograph of the completed model where they fit. The small gap behind the stable has a little gate fixed into it.

The small wall can now be glued to the back of the stable block so that it joins up with the line showing the position of the inn wall. Glue the two walls which make the forge building onto the base. The side wall must line up with the position of the inn wall and the front wall must line up with the front wall of the stable. This will then give you the

completed shape of the courtyard. The gap between the two sections of the front wall is where the main gates will be. When the walls are dry cut out small squares and rectangles of thin card and stick them to the outside of the walls in a random fashion. This represents the owner of the inn attempting to strengthen the wall against possible attack.



Bricking the sides of the courtyard.

TIMBERING THE COURTYARD AND BUILDINGS

The forge building is constructed as a simple framework which stands in the front corner of the courtyard. It is made from three uprights and four cross beams all cut from 5mm balsa wood strip. Templates are provided for these so it is easiest to hold the strip against the template and cut off the required length. PVA glue is sufficient to stick these together but I also carefully pushed pins through each joint to make them really strong so that there is no chance of them breaking in the heat of battle.

With the frame and the basic stable now completed you can begin to put the timber supports onto the walls. The positions are marked as a guide which you can alter if you wish but note that the timbering is on the inside of the walls only; the outside of the walls are bricked over to increase their strength. The long strips of 5mm square balsa which are shown running along the tops of the walls are there to allow you to fix the capping tiles to the walls later on.

As with the inn itself the timber supports are cut from 3mm thick balsa wood and the doors from strips of 1mm thick balsa and you should fix the strips at the top and bottom of the walls

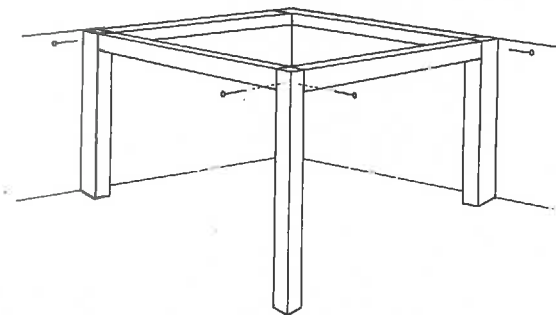

Pinning the forge framework.

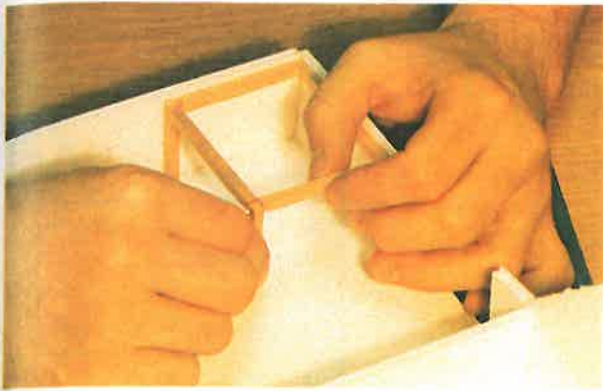

Assembling the forge

before starting the vertical pieces. You will notice from the photographs of the finished courtyard that I put small strips of balsa around the base of the vertical posts of the forge frame. This is something you can do if you have some spare scraps of balsa but which is not really important and can just as well be left off. Also at this stage I cut out four small lengths of 3mm thick balsa wood and stuck them onto the upper level of the front wall of the stable to form the window.

THE STABLE AND FORGE ROOFS

The stable roof is a straightforward construction similar to the tall section of the inn roof, though the roof of the forge is slightly more difficult due to its four-sided shape. The best way to build this is to use sticky tape to hold the four sections together while the glue dries. Make sure that you stick the four sections of the roof together so that the two narrower pieces fit over the ends of the others.

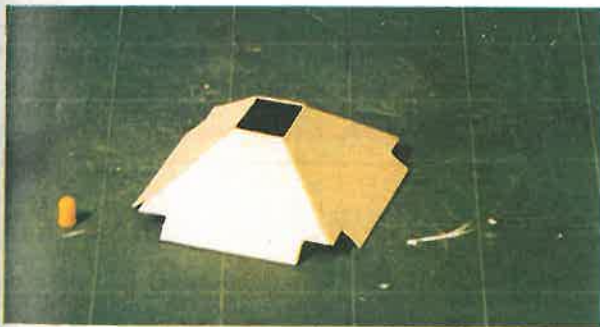

The forge roof.

The hole in the centre is where the chimney will be positioned. While these two roofs are drying check they fit on the buildings and trim the timbers on the walls if necessary. While you are checking the fit of the forge roof mark the position where the roof meets the balsa strip running along the top of the wall. This marks the point where the capping tiles need to be placed.

As before, the roof tiles are cut out of thin card about 8mm x 10mm and stuck on individually starting at the bottom of the roof and working upwards so that each row overlaps the top of the row below it. The wall capping tiles are cut from the same card and are the same size as those used for the roofs. When fixing these on it is easiest to trim the balsa strip running along the top of the wall so that it comes to a point at the top, and the tiles can then be stuck on just as if it were the top of a roof.

THE FORGE FIREPLACE, CHIMNEY AND MAIN DOORS

The fireplace is made in the same way as the chimney of the inn: a base of foam card covered with modelling clay and the brick pattern carved in with a cocktail stick. The fire in the centre is also made from clay into which a cocktail stick or sharpened match has been repeatedly jabbed so that a result similar to hot coals has been produced. When the completed fireplace has dried it can be glued to the base in the centre of the forge using PVA glue.

The chimney is also made from modelling clay which has been shaped into small blocks about 6mm x 3mm x 3mm which are then arranged like a small wall leaving the centre hollow. You get the best result if you can build the chimney while the clay is still wet, but if you find this too fiddly you can leave all the individual blocks to dry and glue them together afterwards. However you build the chimney you should end up with a hollow square about 1cm high. When this has dried it can be glued to the forge roof over the hole.

The double doors into the courtyard are made from two thicknesses of the 3mm balsa wood stuck together. The extra thickness makes the doors look heavier and stronger. Templates for these shapes are provided although you could just as well make the doors flat across the top. I built the doors on my model so that they swing open and closed. This is purely optional although it is rewarding to do it. If you do not want the doors to open simply make the door as per the templates and glue it into the gap in the front wall.

If you do want to build the doors so that they open you will need to do a little preparation work. Glue the two thicknesses of balsa together and leave to dry. Then trim about 2mm off both outside edges of the door and cut down the centre of the door so that you have two halves. Take two pieces of 15 amp fuse wire or other wire of similar thickness 5cm long then, using pliers, carefully bend the top 10mm of each over to a right angle to make the door hangers. Then take four pieces of 10 amp fuse wire about 5cm long and using pliers form a small loop at one end to make the hinges. The loop must be large enough to allow the 15 amp fuse wire to slide through. When you have got the four loops the correct size trim off the spare 10 amp fuse wire so that each loop has a shaft about 1cm coming off it. Two of these loops are then glued into the sides of the doors which will be nearest the frame, one near the top of the door and one near the bottom. The loop must remain clear of the door so that the door will open smoothly. The wire hanger then slides through the two loops so that the bent over section is at the top. This bent over section is then carefully glued into the foam card at the top of the wall and the bottom end is carefully glued to the base card. When the glue has dried you will be able to open and close the doors.

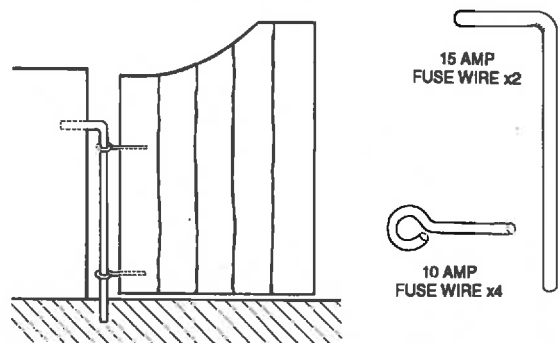

Attaching the doors to the walls

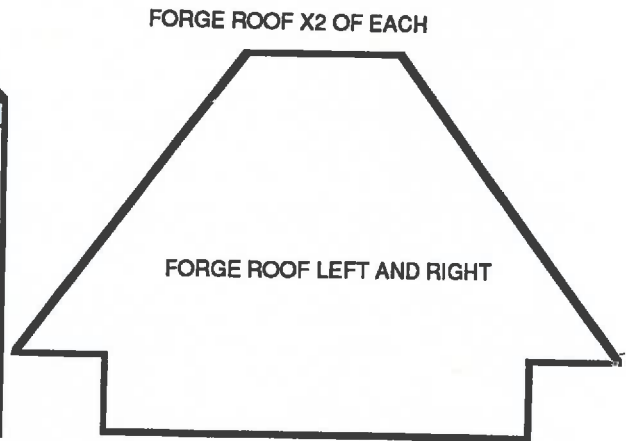
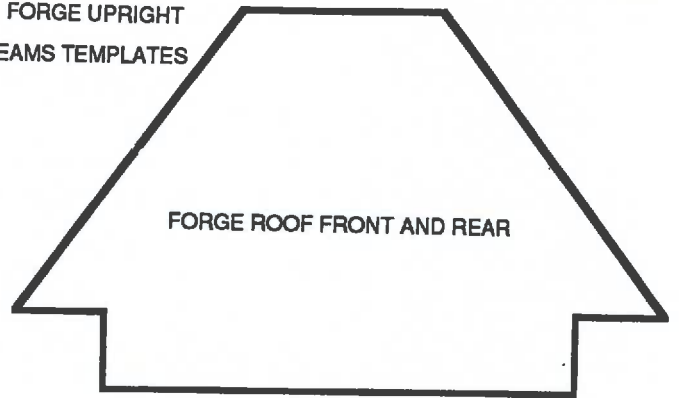
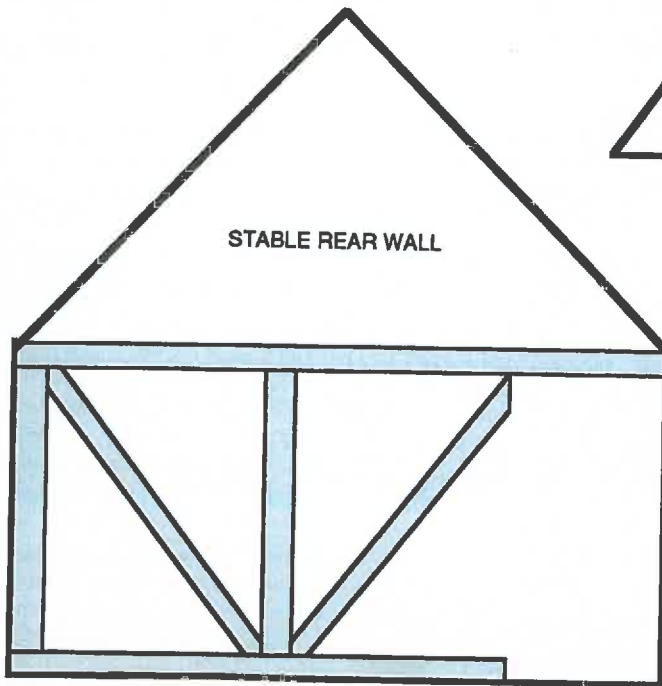
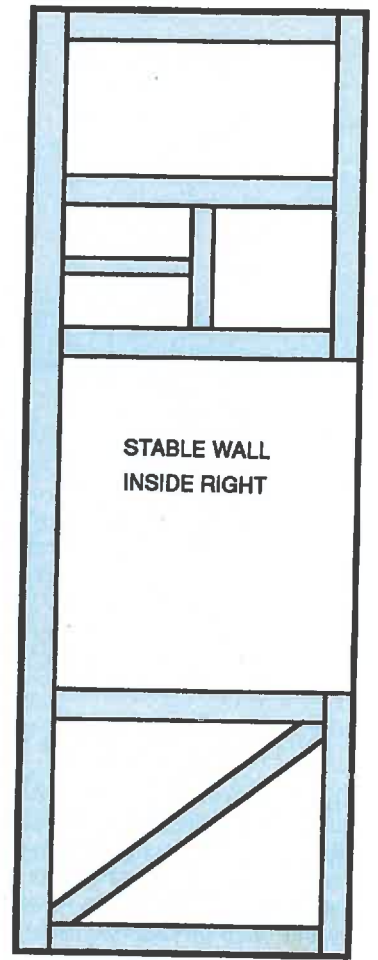
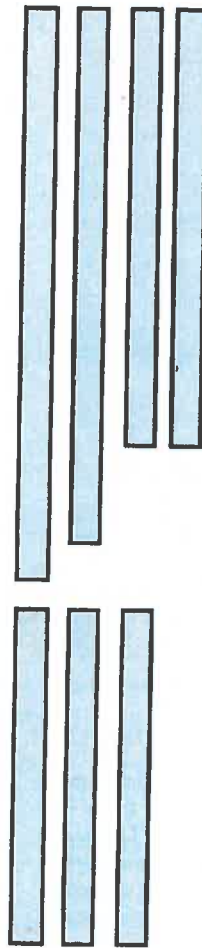
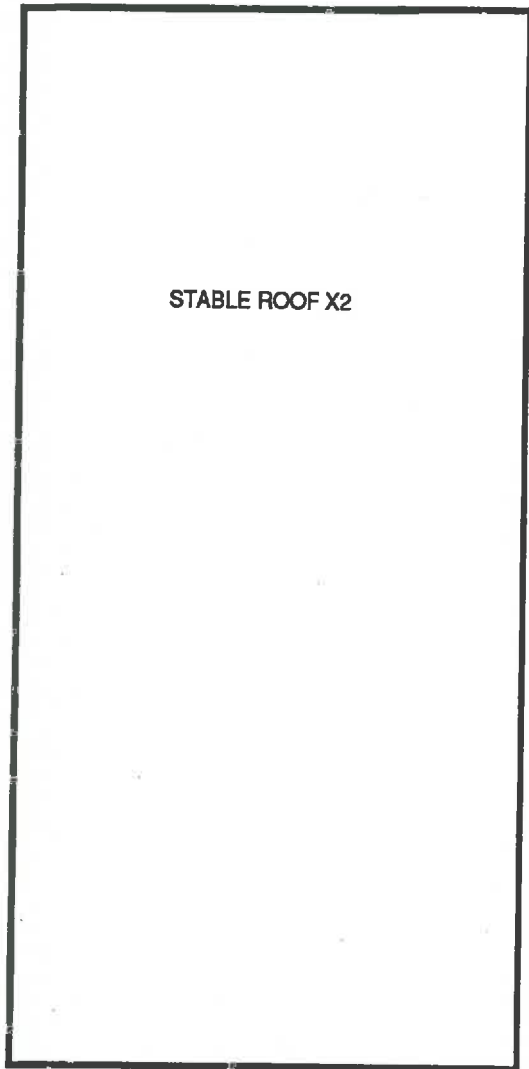

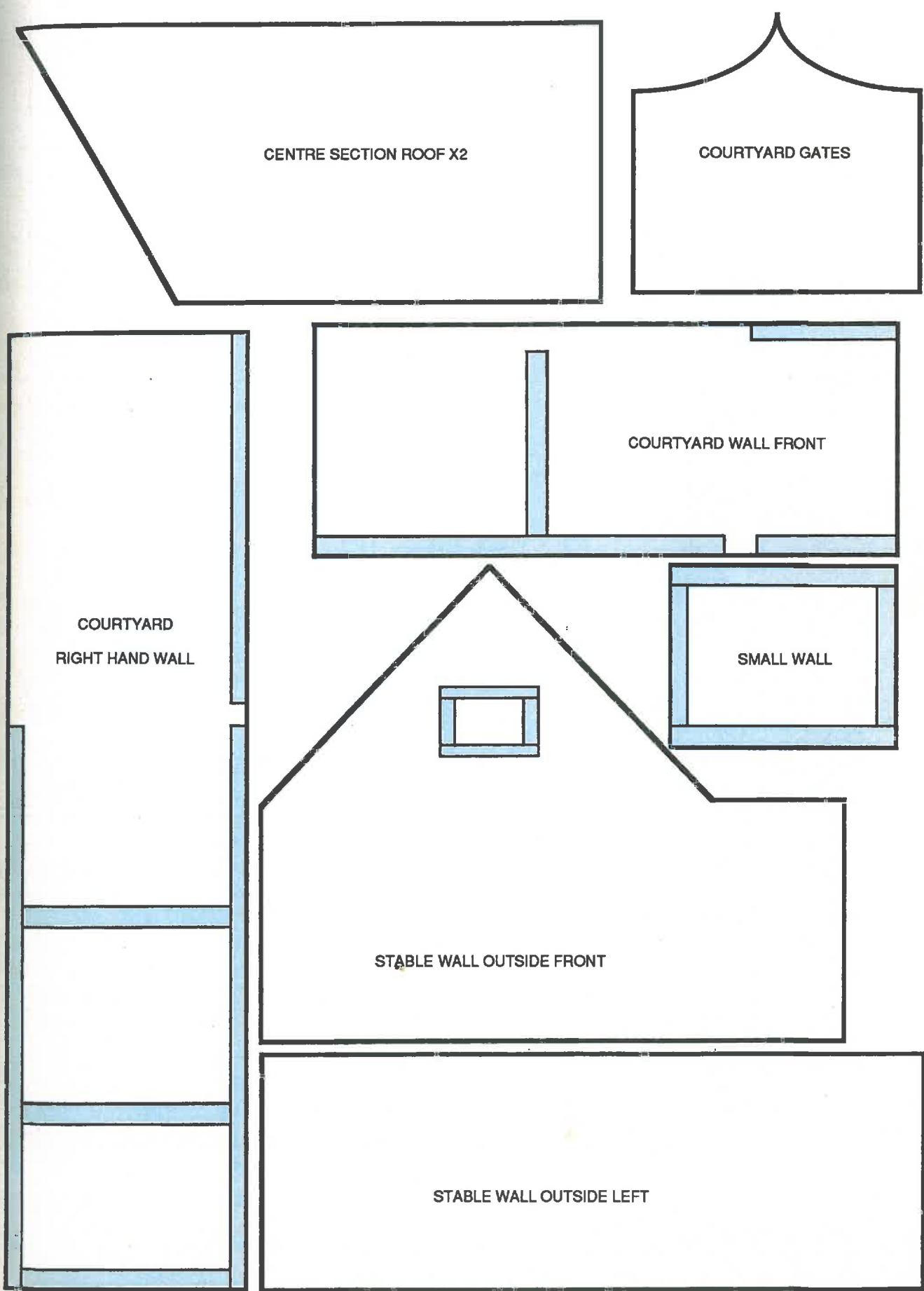

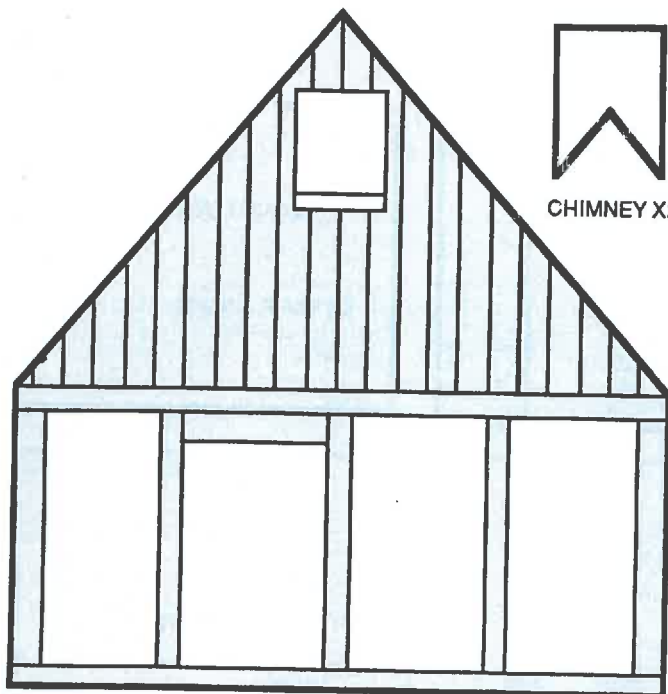

SINGLE STOREY FRONT END WALL



CHIMNEY X2

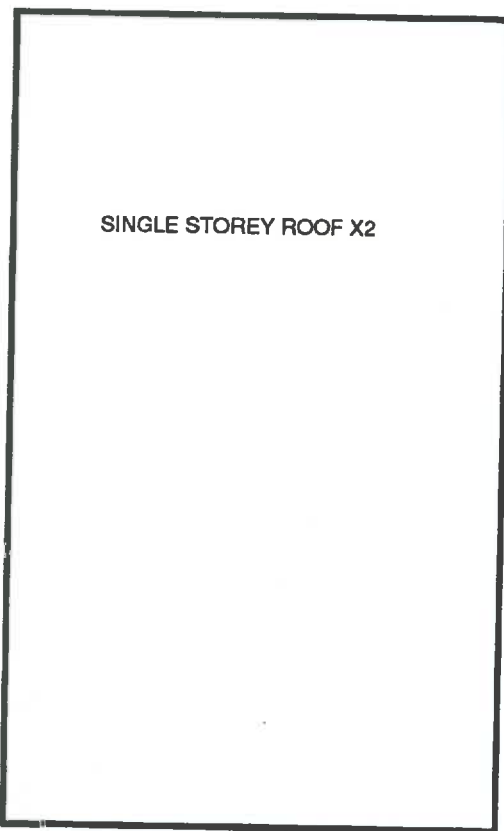

SINGLE STOREY ROOF X2

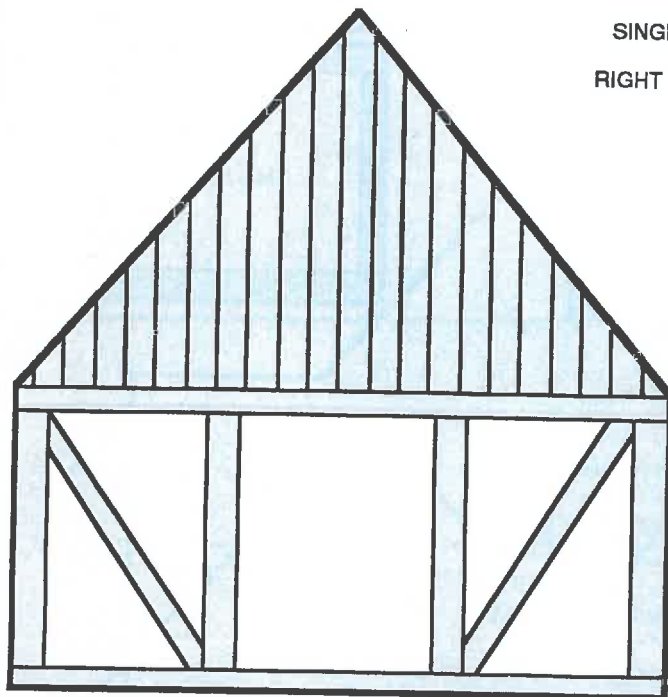

SINGLE STOREY REAR END WALL

SINGLE STOREY
RIGHT SIDE WALL

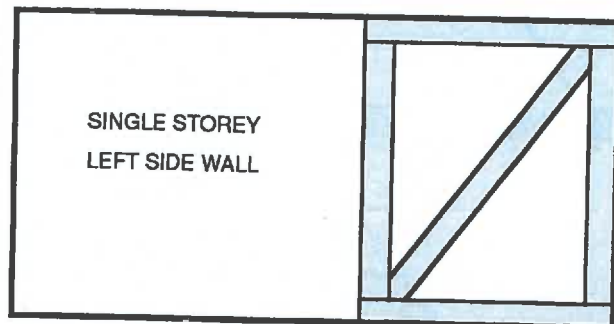
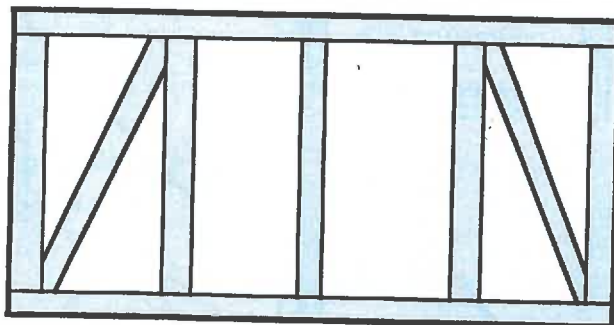

SINGLE STOREY
LEFT SIDE WALL

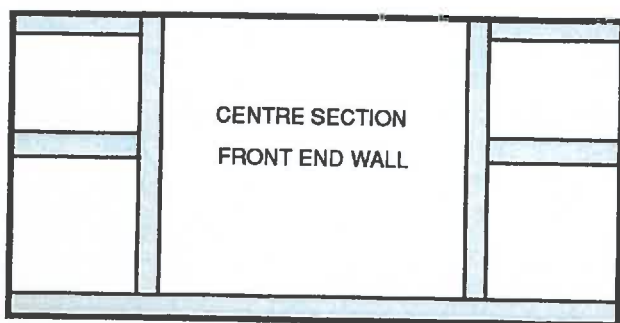

CENTRE SECTION
FRONT END WALL

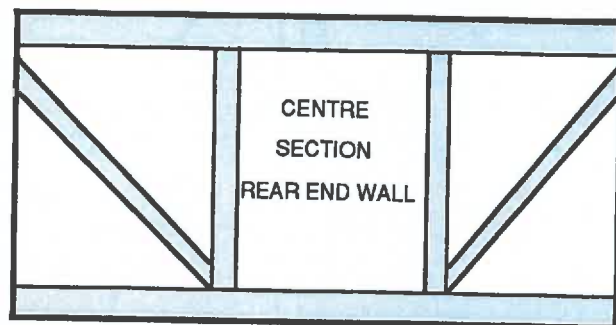

CENTRE
SECTION
REAR END WALL

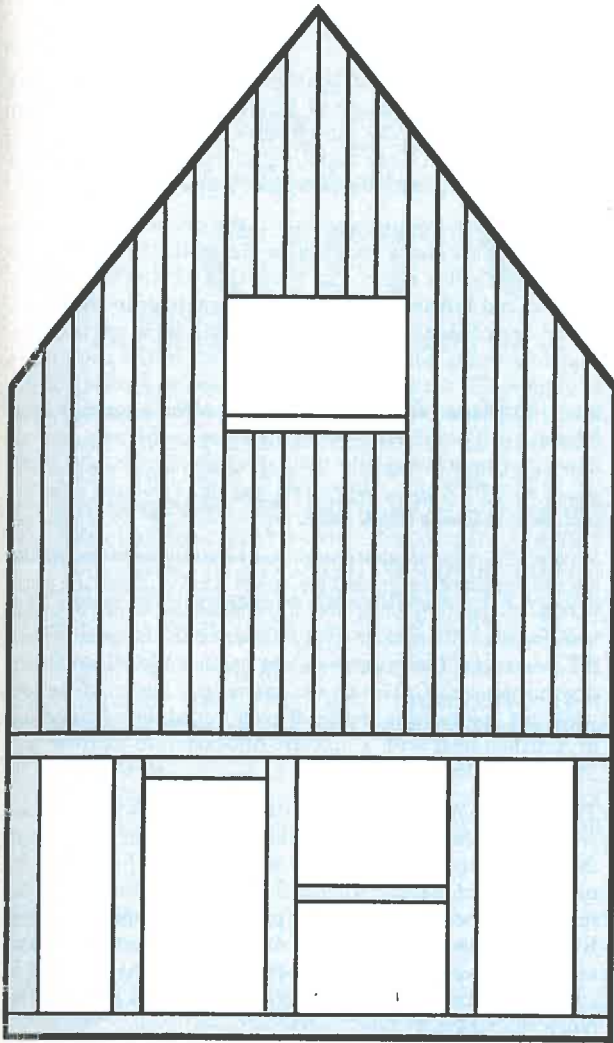

TWO STOREY LEFT END WALL

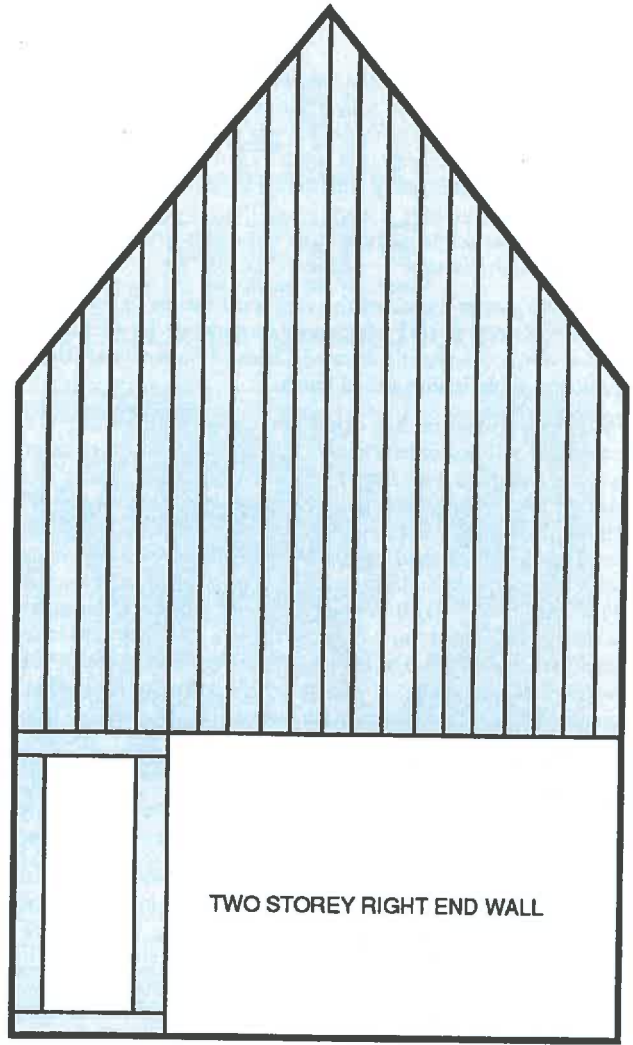

TWO STOREY RIGHT END WALL

TWO STOREY FRONT AND REAR SIDE WALL X2

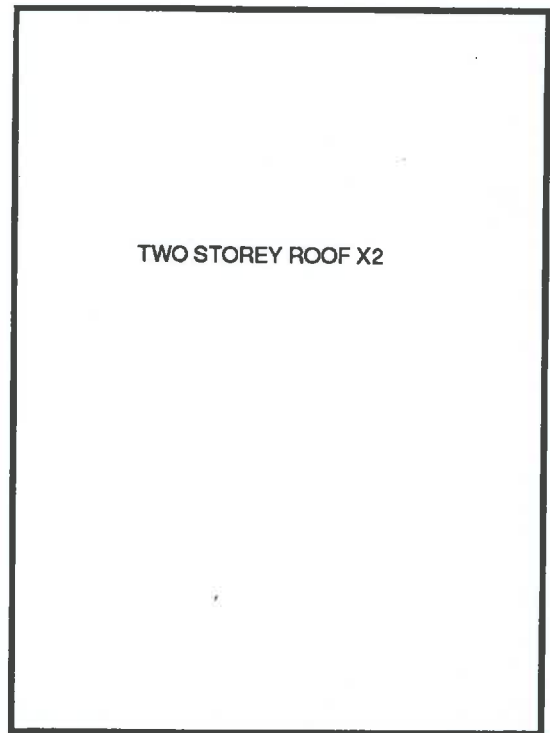
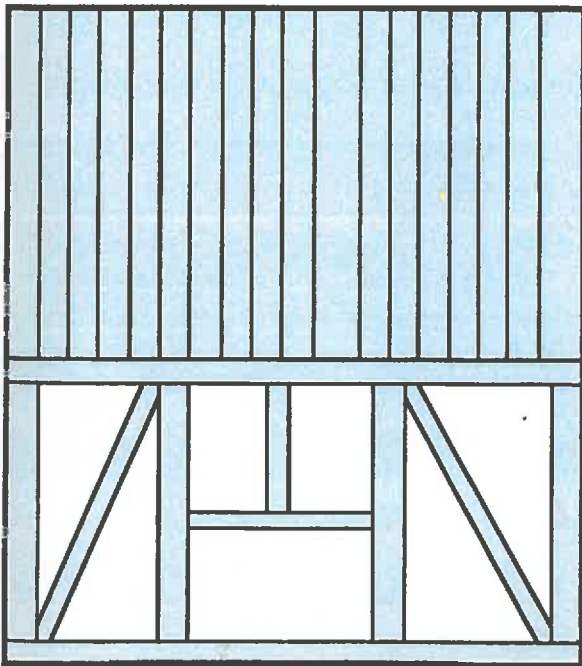

TWO STOREY ROOF X2

PAINTING THE COURTYARD

Like the walls of the inn, the courtyard walls should be given a thin coat of Tetrior or Polyfilla to create a plaster effect. I mixed some fine sand with the Tetrior to give the impression of much thicker and tougher walls. To do this make up the Tetrior so that it is fairly thin then add enough fine sand to make the mixture into a thick soup. Paint this mix onto the walls with an old paintbrush, and when it is dry it will look like old rough plaster.

When the plaster has dried the courtyard can be undercoated in black. I used a black car primer spray paint but you could just as easily use slightly thinned Chaos or Salamander Black paint and apply it with an old brush.

When the undercoat has dried you can begin painting the courtyard. All the timbers except the outside of the large main gates are painted with the same drybrush technique used for the inn. The inside of the gates can be painted like the rest of the timberwork. First drybrush with Bestial Brown paint leaving the black shading showing through, then drybrush with successively lighter coats of Bestial Brown, Bronzed Flesh and finally Skull White paint until you have the same weathered colour as the timbers of the inn. The walls are then painted to match those of the main building: Elf Grey stippled over with Skull White. If you chose to paint your inn grey or cream then paint the courtyard the same colours.

Because the outside of the walls was a much larger area than the small panels it's better to paint it with a drybrush technique rather than by stippling. This will save time and give a better looking finish, particularly if you chose to mix some sand in with your plaster.

The roofs of the forge and stables are painted in exactly the same way as those of the inn building. Starting with a black undercoat, build up layers of drybrushing starting with Terracotta working through successively lighter shades of Blood Angel Orange and a mix of orange and Skull White. Remember to drybrush from the bottom of the roof towards the top until you have a finish which matches the inn.

The chimney and the fireplace are drybrushed with a dark grey colour and then lightly drybrushed again with Elf Grey to

give the final highlights. When you have done this it is a good idea to repaint the inside of the forge chimney black to represent the soot which gathers there. The fire in the pit can be painted in Red Gore and highlighted with Blood Angel Orange and Sunburst Yellow to show the hot burning coals.

The only thing left to paint now is the outside of the main gates, which I chose to paint to match the inn sign. The Sunburst Yellow doors and the stripe of Red Gore were painted and left to dry. Painting the eagle onto the doors would be possible but I decided to cheat a little and used the transfers again. There were no transfers in the pack large enough to fill the two doors as I wanted so I enlarged the transfer I used for the inn sign on a photocopier. I then carefully cut out the design with a sharp craft knife and cut down the centre to make the two halves, then stuck them to the doors with PVA glue. When this was dry I painted over the picture with Chaos Black paint.

With all the painting now completed you only need texture the base to represent the ground inside the courtyard and the grass outside it. Carefully paint over the whole base with PVA glue and sprinkle the fine sand over it. Leave this to dry and shake off the excess. The grass areas are painted Woodland Green drybrushed with Goblin Green and a little Sunburst Yellow while the courtyard is Bestial Brown mixed with Brown Ink drybrushed over with a mixture of Snakebite Leather and Sunburst Yellow.

The whole complex can now be detailed as you wish with cart wheels, ladders, tools and such like. Try not to put too much in the main courtyard area as this would make it difficult to move models around. I added some cracks to the plasterwork of the inn and the courtyard walls by painting thin lines of Chaos Black from the corners of some of the panels and on areas of the outside wall. Don't overdo this effect as the building is supposed to be realistically weathered, not just about to fall down around the landlord's ears!

The model is now finished and I am sure it will become the centre-piece of many hard fought games of Warhammer Fantasy Battle.

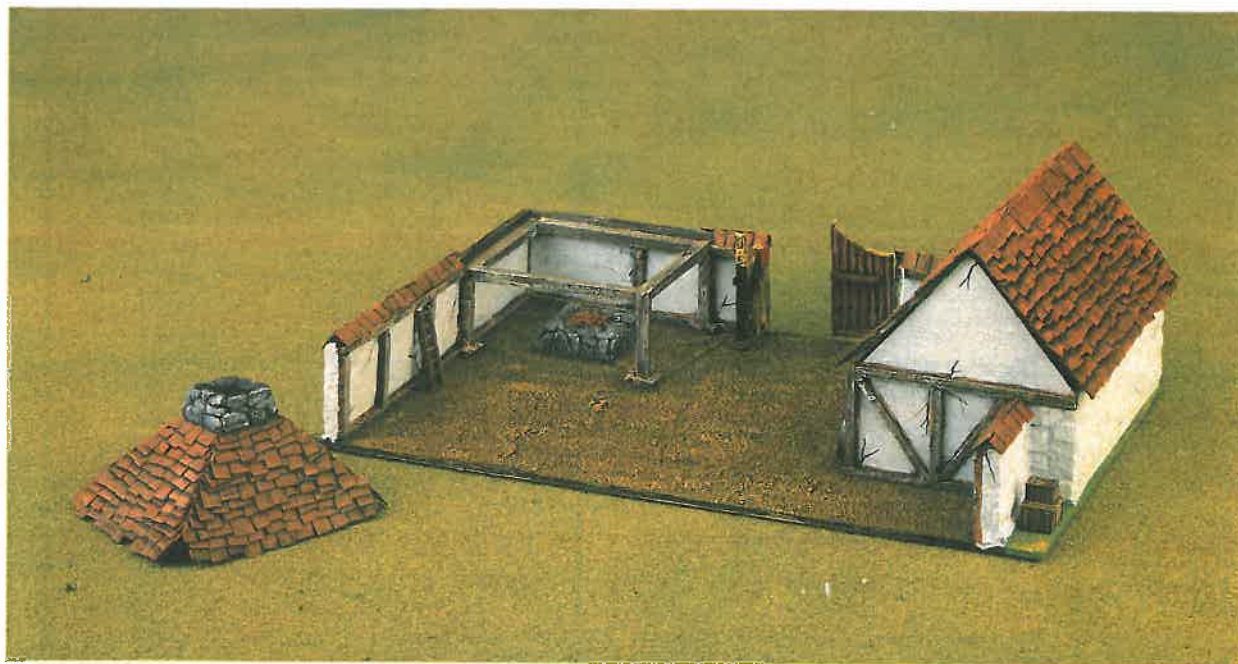

GAMES WORKSHOP®

GIFT VOUCHERS

The perfect answer to all those terrible Christmas present dilemmas!

Games Workshop Gift Vouchers are available in denominations of £5 and £10 (\$20 and \$50 in the USA). They can be exchanged for any items sold by any Games Workshop store or through Games Workshop Mail Order. No longer do you have to struggle to describe exactly which Citadel Miniatures you want for Christmas - just ask for a Games Workshop Gift Voucher and you can choose your own Games Workshop or Citadel Miniatures product.

Games Workshop Gift Vouchers are available now in all Games Workshop stores, or from Games Workshop Mail Order.

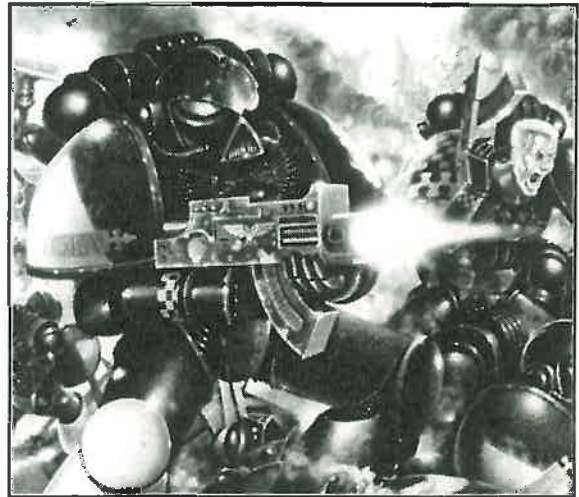

GAMES WORKSHOP®

SHEFFIELD

WARHAMMER DAY

Saturday 23rd November

Games Workshops' Mike McVey and Wayne England will be appearing at the Sheffield shop on Saturday 23rd November 1991.

Mike McVey will be giving painting demonstrations, so if you want to know how to get the best results on those personality models or your basic troop types, don't miss Mike and his brilliantly painted Wood Elf army.

Wayne England will be fielding his superbly painted Dwarven army in the valiant defence of a small village on the edge of the Grey Mountains. Can he withstand the savage horde of malevolent evil that surrounds the entire village?

If you have never played Warhammer Fantasy Battle before, now is your chance to learn by taking part. So bring down your own painted unit of 'evil' or 'chaotic' troops to attack the village. Everyone is welcome.

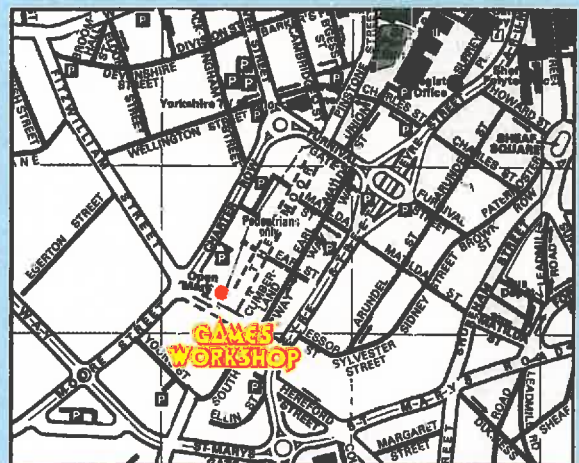

Games Workshop Sheffield
16 Fitzwilliam Gate, Sheffield.
Tel. (0742) 750114



catapult → ballista → Steam → Cannon
 hydraulic rams, screws, scythes etc → floating rams → ironclad → cannon → fighting on higher platforms etc

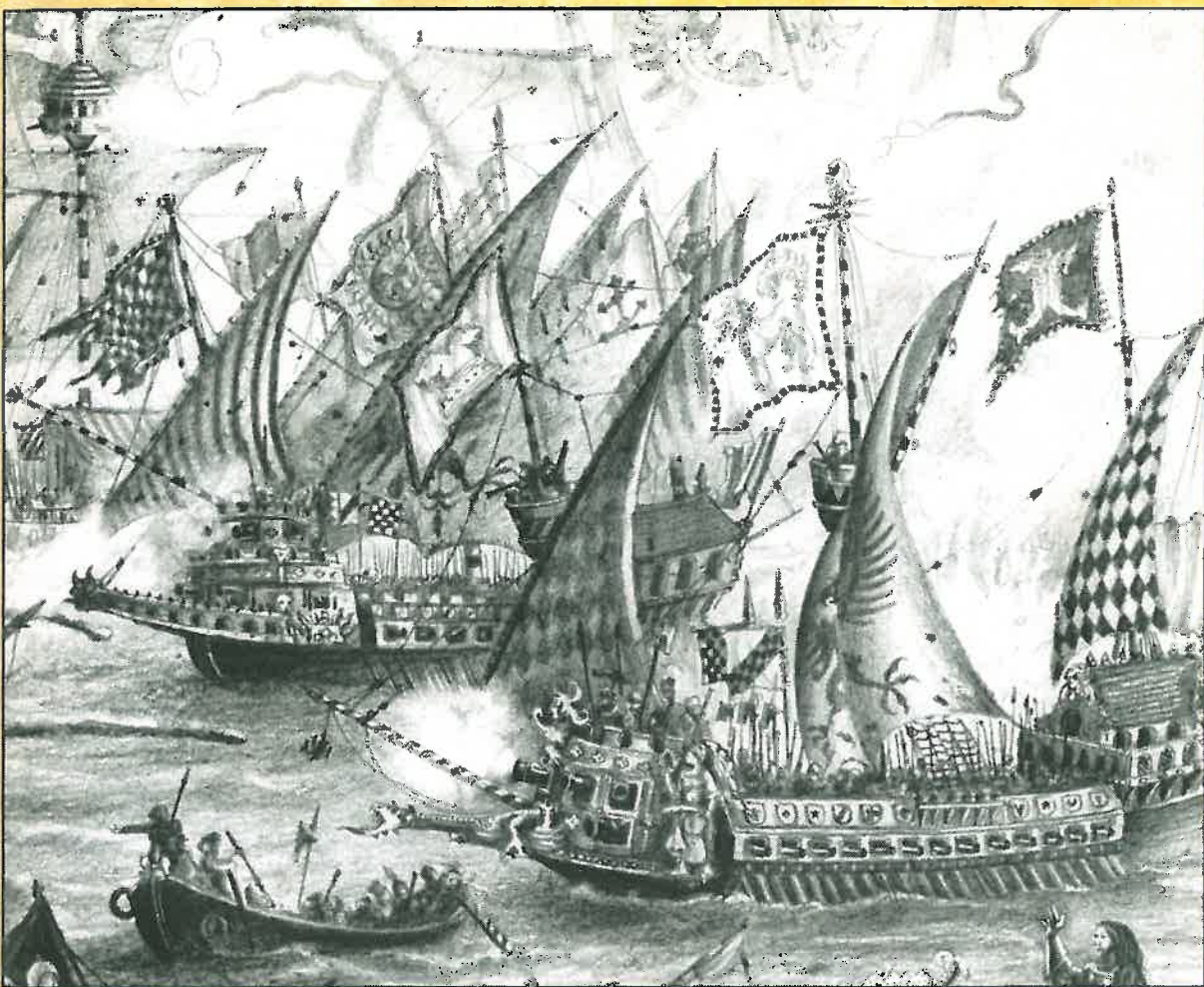

JOHN BLANCHE

GAMES WORKSHOP®

RETAIL STAFF

Do you dread getting up in the morning to go to a job you find about as challenging and interesting as watching paint dry? Wouldn't you rather be spending your time involved in your favourite hobby?

My name is Chris Bone, and I'm a Retail Area Manager for Games Workshop, responsible for the smooth running of the eleven stores in the Midlands.

Games Workshop Retail are always on the look out for energetic, enthusiastic and experienced Warhammer gamers to work in our stores. We need staff who know and understand what our customers want, because they're in the same hobby themselves. Staff who can show new gamers how to play Games Workshop games, teach them how to paint miniatures, and help them choose and collect their very first army.

We're looking for friendly, knowledgeable staff – a sort of cross between a Blue Peter presenter and a professional salesman. The kind of person who has caught the Games Workshop bug and can pass their infectious enthusiasm for the hobby onto others.

It really is a rewarding experience to see a newcomer's face light up as you reveal a whole new world of hobby gaming for his enjoyment.

We are opening more Games Workshop stores all the time, so career prospects are excellent. If you're good at your job, you could soon be managing your own shop!

If you'd like to work for Games Workshop, and think you're the sort of person we're looking for to work in our stores, why not apply?

For a job application form, either see your local Games Workshop store manager or ring the chaps in the Retail Office on 0773 769731.



GAMES WORKSHOP®

NORWICH

OPENING SOON

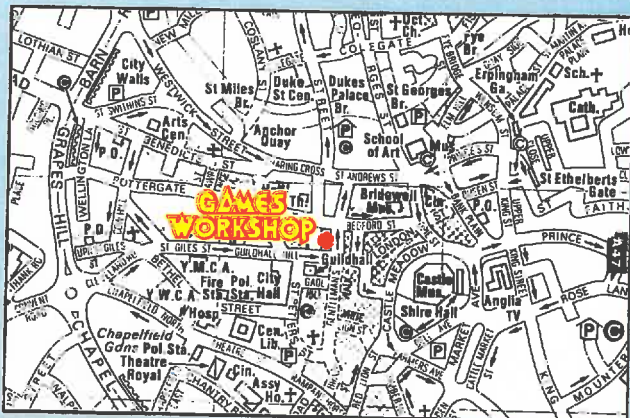

**12-14 EXCHANGE
STREET
NORWICH
NR2 1AU**
Tel: 0603 767656

OPENING TIMES:
10am - 6pm Mon to Fri
9.30 - 5.30 Sat
CLUB NIGHT: THURS UNTIL 8.00 pm

SPACE MARINE

ALAITOC CRAFTWORLD VS THE BLOOD ANGELS

AN EPIC BATTLE REPORT
BY ANDY CHAMBERS & JERVIS JOHNSON

When Jervis and I started putting together armies for Space Marine, it seemed a natural progression to take the forces we'd already painted in 28mm and create Epic armies using the same colour schemes. These armies would also provide the opportunity for us to continue our bitter battles between the forces of the Alaitoc Craftworld and the Blood Angels Space Marines. For those of you who missed it, our last battle report in WD 141 detailed the narrow defeat of Jervis' Alaitoc forces by the Blood Angels under my command.

With the arrival of the new, improved Space Marine rules, Jervis and I both jumped at the chance to escalate our struggles on the Warhammer 40,000 battlefield up to the maximum mayhem quotient of Epic scale!



We wanted to make this a truly apocalyptic struggle so we decided to play the game with 6000 points a side. This comprised the entirety of Jervis' Alaitoc force and almost all of the Blood Angels. Under the new rules, Space Marine games are played until one player gains a preset number of points and achieves victory. Points are awarded for controlling objectives and breaking enemy units. In this game we would be playing to 55 victory points.

Once again we played the game here at the studio on one of our 8' x 4' tables, setting up the terrain using the random system included in Space Marine. The game itself took a full day to play to its conclusion and was a challenging one for both us, if only because of the mammoth forces we had to control.

In the battle Jervis used several of the new and exciting models that have been developed for the Eldar. Over the last few weeks, we've both been feverishly working on rules for these and we were eager to try them out. These new models consisted of an Eldar Avatar, the living embodiment of the shattered Eldar war god Kaela Mensha Khaine; two Warp Hunters, large grav-tanks built around huge distortion cannon and able to tear a gaping hole in the fabric of reality; a pair of Wave Serpents, special Eldar assault carriers which create a rippling bow-wave of energy that can be used both for

protection or as a weapon and finally two Prism Cannon, which concentrate and intensify the power of several smaller units such as lascannon into a single, devastating blast.

As in previous battle reports, we used a polaroid camera to take pictures throughout the game and kept notes on the moves and casualties for later reference. I then used these to re-shoot the photos for this article with proper lighting and cameras. Unlike previous battle reports, we've written up the events of the battle from a neutral standpoint, confining our own commentaries to the sections on planning, deployment and our post-battle conclusions.



WAYNE ENGLAND

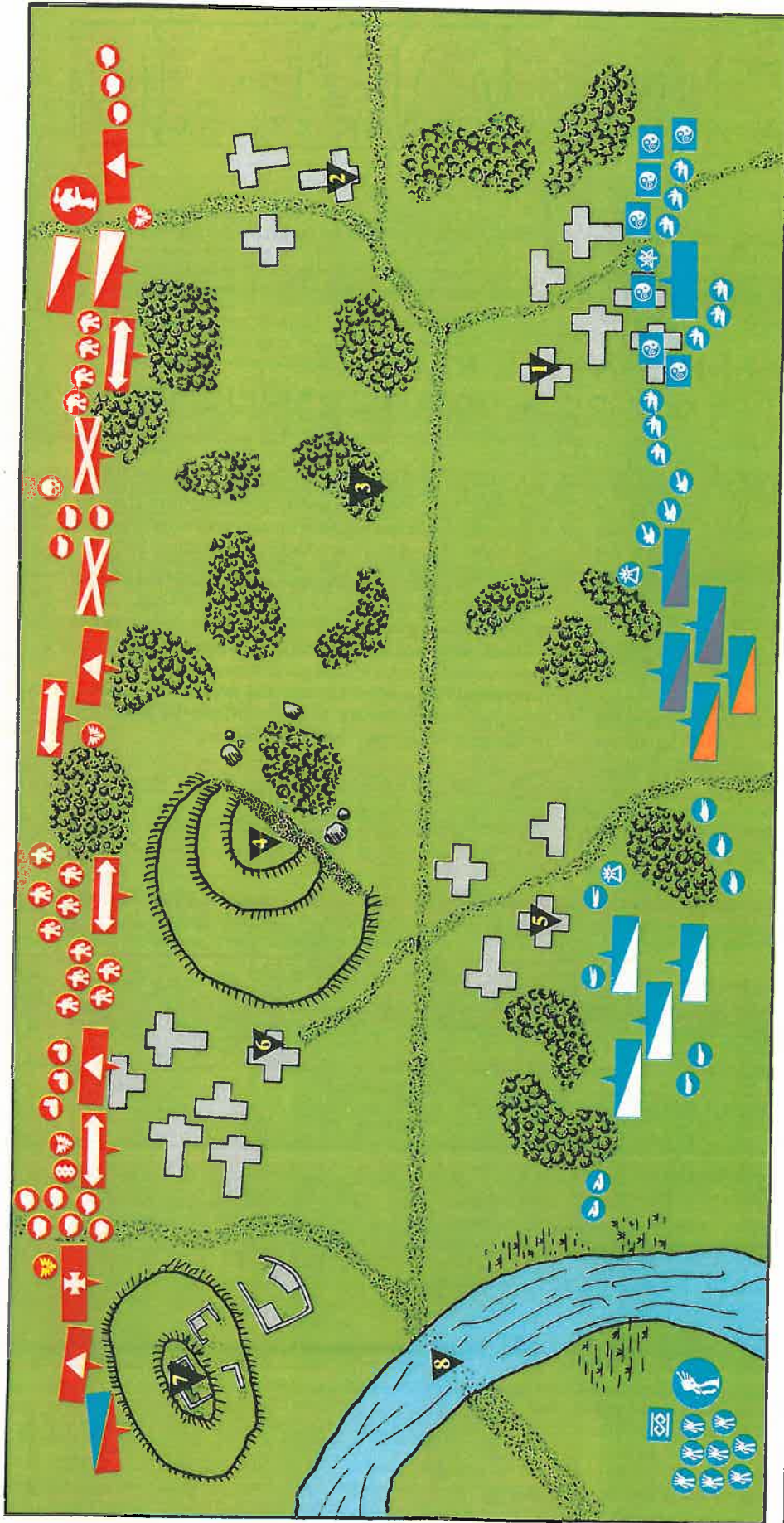

WD42

ELDAR ALAITOC CRAFTWORLD

- | | | |
|-----------------|------------------------|-----------------|
| | | |
| Avatar | Wraithguard | Vyper Jet Bikes |
| | | |
| Warlock | Dreadnoughts | Jet Bikes |
| | | |
| Aspect Warriors | Lascannon | Guardians |
| | | |
| Tempests | Prism Cannon | Phantom Titan |
| | | |
| Warp Hunters | Vibro-cannon | |
| | | |
| Wave Serpents | Guardian Shieldbearers | |

BLOOD ANGELS SPACE MARINES

- | | | |
|----------------|----------------|----------------|
| | | |
| Chaplain | Tactical Det | Land Raiders |
| | | |
| Medic | Devastator Det | Land Speeders |
| | | |
| HQ Land Raider | Dreadnoughts | Bike Squadrons |
| | | |
| HQ Units | Robots | Warlord Titan |
| | | |
| Terminators | Vindicators | |
| | | |
| Assault Det | Whirlwinds | |

THE ELДАР PLAN

(JERVIS JOHNSON)

As we were playing a 6,000 point game my choice of which units to take was simple – I've only got a 6,000 point Eldar army so I took the lot! Now all I had to do was come up with my master plan...

After winning the deployment dice roll, I was presented with my first tactical decision: which table edge should I choose for my set-up? The most obvious edge to take was the top one. This half of the table contained five objectives and had plenty of cover. However, a large proportion of my force (the Jet Bikes, Vypers and Aspect Warriors) are at their best in close combat. My favourite tactic for these troops is to move them into dense terrain in the opponent's half of the table, from where they can employ their 'hit and run' close combat attacks without being gunned down as they move about.

With this in mind, I wanted to try and move them into the top-right quarter of the table, where the thick woods and large buildings would provide them with excellent cover. This would also block off most of Andy's lines of sight, cutting down the amount of incoming fire they would take. Therefore I plumped for the bottom edge of the table as my set-up zone.

For the reasons described above, I planned to use the Jet Bikes and Aspect Warriors on the right flank while the rest of my army would go in on my left where the more open terrain would suit their style of fighting.

When formulating your plan, it is vitally important to pick out which objectives you want to try and capture. Doing this in advance makes it easier to decide how best use your forces to achieve your ends. In order to win the game you really need to capture at least five objectives and probably six. Don't go for all eight – you'll just stretch yourself too thin and get gunned down early in the game. I usually pick five 'primary' objectives that I'll attempt to capture and hold at all costs, plus one or two 'secondary' objectives that I'll have go at if the circumstances are right.

I decided to place the Phantom and Wraithguard on the extreme left, where they could advance and capture objective 8. The War Host would capture objective 5 and then dismount to occupy the nearby buildings and woods. These forces would be supported by the bulk of my other 'long range' specialists – Tempests, Prism Cannon Guardians and Warp Hunters – plus the Harlequins, mounted in the new Wave Serpents. Most of these troops would be used to enter a firefight with whatever forces Andy had in the area, hopefully blowing enough of them away so that my Harlequins would easily capture objective 6 once they reached it.

I placed my Vypers towards the centre of my line. From here they could charge quickly into the woods on Andy's side of the table (capturing objective 3 in the process), or be redirected to my right or left flanks if needed. I also placed a Warlock and some Lascannon here, to provide a bit of long range firepower in the centre of the table.

The Aspect Warriors were placed behind the buildings on the right, along with all my Vibro-cannon and a small group of dismounted Guardians. The Guardians would be used to hold objective 1, while the Vibro-cannon would provide supporting fire and make Andy think twice about occupying any of the buildings around objective 2. I then planned to use the Aspect Warriors to work their way forwards through the woods and capture objective 2. Once this was safely in my hands, the

Aspect Warriors would swing left and try to capture objective 3 if the Jet Bikes had not already done so.

My plan was now complete. I had five 'primary' objectives (counters 8, 6, 5, 1, 2) and one secondary objective (counter 3). I would quickly seize the objectives on my half of the table, use the Harlequins to capture objective 6 supported by the bulk of my Guardians. The Aspect Warriors were set to capture objective 2 and the Jet Bikes, if the circumstances were right, to take objective 3. I hoped that this the plan would also allow me to use each troop type to their best advantage, emphasising their strong points and minimising their weaknesses.

ARMY STRENGTHS & WEAKNESSES

It's important in Space Marine to keep in mind the strengths and weaknesses of *all* the units in your army. The Eldar are particularly interesting in this regard because each type of unit is quite specialised. However, it is possible to split the units into three broad categories; 'fast attack' units (Jet Bikes and Vypers), Aspect Warriors (including the Avatar, Exarchs and Harlequins) and Guardians (War Hosts, Tempests, Phantom Titans, Vibro-Cannon and other supporting units).

The Jet Bikes and Vypers make excellent 'fast attack' units. They are highly mobile and can be on top of your opponent before he knows what's hit him. Their close assault factor of +3 also makes them extremely good in close combat. On the other hand, they are very vulnerable to enemy fire and next to useless sent against infantry that are in woods or buildings.

The Aspect Warriors are awesome close assault troops, a match for even the dreaded Terminators. However, they are also very vulnerable to enemy fire and because they are not as fast as the Jet Bikes you must take care to move them up under cover. This means that they are very poor at fighting in open terrain.

The rest of the Eldar units are just about the opposite of the Jet Bikes, Vypers and Aspect Warriors. They excel in long range fire-fights, but suffer badly if the enemy manages to close in. For this reason you should get them into a good firing position as early as possible and then stick them on first fire orders so that they can blast away at the enemy to best effect.



STEPHEN TAPPIN

SPACE MARINE PLAN

(ANDY CHAMBERS)

Having six thousand points meant I would be able to field nearly the entire Blood Angels army. I therefore set about picking my force safe in the knowledge that for once I wouldn't have to compromise my choices due to lack of points.

I started by selecting my company cards. I always prefer to field as many full companies as possible. The higher break point of these larger formations means they can survive casualties for much longer before having to check morale or give away any precious victory points to the opposition.

Of course when a company breaks, all of its detachments have to check their morale (not all of its stands like it says on the playsheet) and your opponent gets a whole bunch of victory points, something which could swing a whole battle. But the principle is that by the time your own companies are close to breaking, your opponent's formations should already be in little pieces on the floor.

The first two companies I chose were a Space Marine Tactical company and a Battle company. The Tactical company is reasonably cheap and supplies plenty of excellent Space Marine Tactical squads. The Battle company's mix of Tactical, Assault and Devastator Space Marines makes it an ideal formation for all occasions.

As I would be up against Eldar and their plethora of skimmers, I wanted plenty of Devastator stands to threaten the Falcon Grav-tanks when they started to make pop-up attacks. (Skimmers on first fire orders can make a special pop-up attack, rising up from behind cover to shoot in the first fire phase and then dropping out of sight again before the advance fire phase.) Hence the third company I selected was a Devastator company. Although expensive, the firepower of eighteen Devastator squads is quite phenomenal.



JES GOODWIN



The fourth and final company I chose was a Land Raider company. Though the Land Raider company is rather brittle, with a break point of only five, Land Raiders are actually very tough tanks, with good firepower, armour and speed. These attributes, combined with the fact that they are relatively cheap at 600 points for a company of ten, makes them a very good buy. I knew that the Eldar would be using a Titan and the Land Raiders would be one of the few things in my army that could hope to penetrate a Phantom Titan's tough armour.

I now turned my attention to the support cards. Each full company in my force entitled me to use five support cards, so with four companies I could potentially purchase up to twenty cards! Obviously I didn't have anywhere near enough points to obtain all of these, but I could try and cover some types of units I didn't have at company strength.

First of all I wanted some Whirlwinds. The indirect barrage support they can provide would come in very handy wherever I deployed them. Vindicators are a personal favourite of mine, so I took a squadron of them for old times' sake, though their monstrously potent gun demands the respect of any opponent. I also took an extra detachment of Space Marine Assault troops as their high close assault factor and jet-packs make them extremely good at storming objectives. Naturally, I couldn't fight such a major battle without taking some elements of the veteran no. 1 company along so I also bought a Terminator detachment.

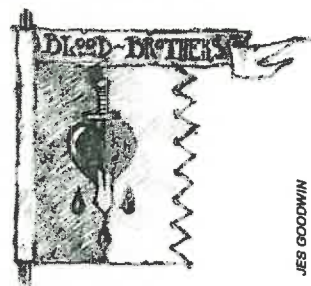

JES GOODWIN

In an attempt to stop some of the inevitably numerous Eldar Jet Bikes swarming all over me, I took a single squadron of Land Speeders. In a similar vein I also took two squadrons of Bikes, slightly less mobile than Land Speeders but cheaper. It is incredibly easy to get both Bikes and Land Speeders killed quickly by charging rashly into the heart of the enemy. On the other hand, if used well, they can be devastating. In another of my recent battles, a squadron of five Land Speeders single-handedly destroyed a Reaver Titan by just outmanoeuvring the Titan and hitting it repeatedly with their potent Multi-Meltas. Two rounds of combat and the Reaver was a bubbling pool of plasma!

Another personal favourite of mine are Dreadnoughts and robots. I find them really handy for close support of infantry both in attack and defence. Though walkers aren't as tough as tanks, they are cheap, fairly numerous and tough enough to bolster up infantry. Although their limited programming can be frustrating, robots also have the advantage of only breaking once they've been completely wiped out. I therefore took a single Dreadnought detachment and two detachments of robots.

The total points value of my company and support cards so far was five thousand points, leaving me one thousand points to spend on up to four special cards (one per company). I already knew exactly what I wanted from the special cards: a Warlord Titan plus the Blood Angels' Chaplain and Medic. Total cost exactly one thousand points!

There's no way I would fight a battle this large without taking at least one Titan. All that yummy firepower, concentrated in one place and protected by void shields and hefty armour is just too useful to ignore. The Chaplain and Medic are relatively cheap and supplement the troops they accompany with a handy +1 close assault factor or 5+ saving throw respectively. So, with my forces all selected it was time to come up with a plan.

After examining the terrain and the positions of the objectives my initial thought was to mass my forces exclusively in the more open terrain on my right flank. The thing that made me

uncomfortable about the centre and left was the relatively close terrain. The assortment of highly potent Eldar assault troops in Jervis' army – Striking Scorpions, Howling Banshees, Harlequins and Exarchs – are all virtually untouchable in close combat and would have plenty of cover to advance through. On top of this, his Jet Bikes would doubtless be dogging my every move and making the woods in the centre a very dangerous place to be.

Massing on my right would prevent me having to play hide-and-seek with Jet Bikes and Vypers amongst the woods in the centre and probably give me enough forces to overrun objectives 4, 5, 6, 7 and 8 relatively easily. The problem with this plan was that it would leave my left flank open to attack from whatever Eldar forces were left unchallenged on the rest of the table. I could leave a portion of my forces to guard the left, but that would reduce the amount of troops I had to attack objectives 5 and 8, potentially pushing my casualties up to an unacceptable level. The other problem with massing my forces exclusively on the right was the simple fact that it would be physically hard just to deploy them all efficiently in such a limited area.

So, after scrapping my first idea I decided to try a slightly more conservative deployment which stretched across the whole table, but still massed a significant portion of my forces on the right. The idea was to try and 'pin' the Eldar to prevent them redeploying forces against my main attack up the right flank. I would launch this attack as soon as I had weakened the Eldar defenders enough to move forward without taking horrendous casualties as I crossed the open ground.

It was still important for me to place a strong force on the right as three objectives lay easily within my reach and a fourth, objective 8, would be a relatively easy acquisition. Even if I decided not to attack objective 5 it would be essential to keep a strong grip on the area and deny these objectives to the Eldar.

The holding forces in the centre and left would advance and grab objectives 2 and 3 and then push forward to grab objective 1 if resistance turned out to be weak. If the holding forces came under too much pressure they would withdraw and try to inflict maximum casualties and slow the Eldar down while I put in a counterattack elsewhere.

The main advantage of this plan was that if the Eldar deployment proved to be completely incompatible with my fiendish plans I would be able to redeploy troops fairly easily. This would allow me to exploit weaknesses and cover gaps, instead of tying my fate inextricably to the action on the right flank.

You can see my overall position on the deployment map and a few points are worth noting. First of these is the placement of the robots in the centre. These robots were programmed with capture orders so they would advance up the hill and then go onto first fire orders and guard the objective. In this way, they would form a strong 'hinge' for my advance on the right and protect the objective at the same time.

The second is the placement of the assault troops in the centre. This was done for two reasons: to have them in a position to move and reinforce either flank and to make use of their jump packs to overcome the difficulties of moving through the heavily wooded area. Finally, I tried to place my devastators in areas where they could not only get into cover in the first turn, but also have reasonable fields of fire, thus allowing them to stay on first fire orders throughout the rest of the game.



ARMY STRENGTHS & WEAKNESSES

The Space Marine army definitely benefits from having quality infantry. Even tactical squads have a close assault factor of +2 and a morale value good enough to turn opponents green with envy. In addition, these splendid troops come complete with Rhinos, whose high speed makes them invaluable for advancing forces onto objectives early in the game. Excellent specialised types of infantry also abound, with Assault troops, Devastators, Veterans and the much-feared Terminators available to fulfil any required task. The Space Marines have some excellent battle tanks in the Land Raider and Vindicator, both of which have a reasonable speed, solid armour and good firepower.

The Space Marines also have some good light equipment. Land Speeders and bikes are useful for their high speed and close combat ability, though they can be a little fragile. Barrage support is furnished by Whirlwinds, Mole Mortars and Thudd Guns.

Nonetheless the Space Marines' biggest strength is its infantry and consequently they are best used in terrain which affords plenty of cover.

The greatest failings of the Space Marines are their lack of heavy artillery and powerful, super heavy tanks, such as those used by the Imperial Guard. The nature of the Space Marines as a rapid deployment force makes it impossible for them to lug such hefty pieces of kit around the galaxy. Inevitably they can sometimes run into heavily armoured opponents, like Titans, which they have great difficulty dealing with. Hence it's always wise to include a Titan or two with a Space Marine force to handle the big stuff.

ALAITOC ELДАР CRAFTWORLD ARMY



- | | | | |
|-------------------------------------------------------------------------------------|-----------------------------------------------------------------|-------------------------------------------------------------------------------------|-----------------------------------------------------------------------------------------|
|  | 1 Avatar |  | 1 Wraithguard detachment (4 Wraithguard stands) |
|  | 1 Harlequin Troupe (4 Harlequin stands) |  | 2 Dreadnought detachments (each with 4 Dreadnoughts) |
|  | 2 Warlocks (each with 1 Warlock & 1 Falcon Grav-Tank) |  | 1 Anti-Grav Lascannon Battery (3 Lascannon stands) |
|  | 1 Striking Scorpion Aspect Warriors (4 stands) |  | 2 Prism Cannon Batteries (each with 1 Prism Cannon and 3 Lascannon stands) |
|  | 1 Dark Reaper Aspect Warriors (4 stands) |  | 3 Vibro-Cannon Batteries (each with 3 Vibro-Cannon stands) |
|  | 1 Howling Banshee Aspect Warriors (4 stands) |  | 1 Guardian Shieldbearer detachment 6 Guardian stands) |
|  | 1 Swooping Hawk Aspect Warriors (4 stands) |  | 2 Vyper Jet Bike Squadrons (each with 6 Vyper 5 stands) |
|  | 1 Dire Avenger Aspect Warriors (4 stands) |  | 3 Jetbike Squadrons (each with 5 Jet Bike stands) |
|  | 1 Fire Dragon Aspect Warriors (4 stands) |  | 4 Guardian detachments (each with 6 Guardian stands and 3 Falcons Grav-Tanks) |
|  | 1 Tempest Squadron (3 Tempests) |  | 1 Eldar Phantom Titan |
|  | 1 Warp Hunter Squadron (2 Warp Hunters) | | |
|  | 1 Wave Serpent Squadron (2 Wave Serpents) | | |

Total Points: 5950

BLOOD ANGELS SPACE MARINE ARMY



1 Chaplain
(1 Chaplain stand and 1 Rhino)



1 Medic
(1 Medic stand and 1 Rhino)



1 HQ Land Raider



3 HQ Units
(each with 1 Command stand and 1 Rhino)



1 Terminator detachment
(4 Terminator stands and 2 Land Raiders)



2 Assault detachments
(each with 6 Assault stands and 3 Rhinos)



4 Tactical detachments
(each with 6 Tactical stands and 3 Rhinos)



4 Devastator detachments
(each with 6 Devastator stands and 3 Rhinos)



1 Dreadnought detachment
(4 Dreadnoughts)



2 Robot Detachments
(each with 5 Robots)



1 Vindicator Squadron
(3 Vindicators)



1 Whirlwind Squadron
(3 Whirlwinds)



3 Land Raider Squadrons
(each with 3 Land Raiders)

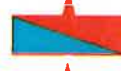

1 Land Speeder Squadron
(5 Land Speeder stands)



2 Bike Squadrons
(each with 5 Bike stands)



1 Warlord class Titan

Total Points: 6000



TURN ONE

The Eldar won the initiative and forced the Space Marines to move first. The Blood Angels rumbled into the buildings and ruins on their left and advanced into firing positions according to plan. The forces in the woods and the buildings on the right deployed poorly, some impeded by the need to manoeuvre around the dense terrain and some slowed to a crawl by only having advance orders.

The Eldar moved decisively against the Blood Angels weakly deployed forces. On the right Exarchs pounced on the Space Marine bikes while Vyper Jet Bikes swept into the woods to attack the Space Marine Vindicators and Rhinos. On the left and right Eldar Guardians moved forward to occupy both towns. The Wraithguard with the Eldar Phantom in their midst strode forward along the left bank of the river towards the ford and objective 8.



The only exception to this confusion was the Blood Angels Assault troops who quickly negotiated the woods with the aid of their jump packs and seized objective 3. The Devastators on the right advanced to objective 2 but only managed to deploy two squads onto the objective, the rest dismounting into the building behind. The Space Marine Bike squadrons wheeled away further to the right, deviating from their intended route to avoid the massed Eldar firepower ahead of them.

During the combat phase a sharp exchange of fire on the left resulted in the destruction of one of the Terminators' Land Raiders by an Eldar Tempest and the demise of three Eldar Dreadnoughts, smashed by the Devastators' missile launchers. On the right the Exarchs demonstrated their crushing superiority in close combat and easily swept away four of the Space Marine bike squads. They then exhibited the one failing of such superlative troops by losing one of their squads to fire from the Land Raiders which had advanced behind the bikes, waiting for just such an opportunity.

The Space Marines' Titan and Devastators rained fire upon the approaching Eldar, wrecking three Vibro-cannon and killing a squad of Dark Reapers. One of the Devastator squads on objective 2 was destroyed by return fire. Close assaults by the two squadrons of Eldar Vypers in the woods destroyed the entire Vindicator squadron without a casualty as well as two of the Assault troops' Rhinos for the cost of one Vyper.



ELDAR ALAITOC CRAFTWORLD

- | | | | |
|--|-----------------|--|-----------------|
| | Avatar | | Lascannon |
| | Harlequins | | Prism Cannon |
| | Warlock | | Vibro-cannon |
| | Aspect Warriors | | Guardian |
| | Tempests | | Shieldbearers |
| | Warp Hunters | | Vyper Jet Bikes |
| | Wave Serpents | | Jet Bikes |
| | Wraithguard | | Guardians |
| | Dreadnoughts | | Phantom Titan |

BLOOD ANGELS SPACE MARINES

- | | | | |
|--|----------------|--|----------------|
| | Chaplain | | Dreadnoughts |
| | Medic | | Robots |
| | HQ Land Raider | | Vindicators |
| | HQ Units | | Whirlwinds |
| | Terminators | | Land Raiders |
| | Assault Det | | Land Speeders |
| | Tactical Det | | Bike Squadrons |
| | Devastator Det | | Warlord Titan |



The opposing forces advance to seize their turn one objectives on the right flank

TURN 1 TACTICAL NOTES

CLOSE COMBAT

The Space Marines lost quite a lot of squads and vehicles in close combat on the first turn. This is because close combat in Space Marine is particularly deadly. Close combat occurs when squads or vehicles on charge orders end their movement in contact with enemy units. Both players roll dice and add their unit's close assault factor to the roll. The player with the lowest total loses the combat and is destroyed – no saving throw! As you can see, assault troops with jet packs, Bikes, Jet Bikes and Rough Riders - which all have high close assault factors and move fast, can be tremendously effective if they're used in the right way.

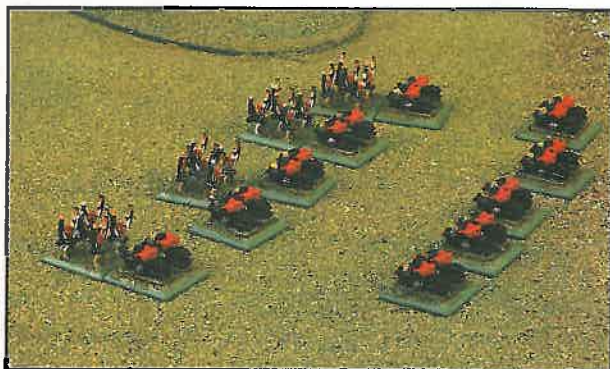

Eldar Exarchs ambush the Space Marine Bike Squadron

Many people throw their specialist close combat troops into a fight without much thought about the consequences. This usually results in the troops being gunned down by enemy fire in a number of ways. Vehicles or squads on first fire can shoot at close combat opponents before the combat is resolved and this can account for a lot of would-be attackers. If they manage to survive this fire and the subsequent close combat, they can still be attacked. Nearby enemy units on advance orders (or units which have first fire orders but have waited until the advance segment) can fire on enemy close combat troops after they've killed their opponents and should always do so unless they want to be next!

One way to avoid having your close combat troops shot at in this way is to use them to 'ambush' enemy units. This means that you pick out and attack small groups of enemy troops who are on their own, unsupported by other forces and preferably on advance or charge orders so they can't shoot back! The attack by the Eldar Vyper squadron on the Space Marines' Vindicators in turn one is an excellent example of a close combat 'ambush' attack.

TURN 1 VICTORY POINT TOTALS

Alaitoc Craftworld: 15 VP

Blood Angels : 26 VP

TURN TWO

The Space Marines won the initiative and forced the Eldar to move first. On the left the Wraithguard continued to advance and started to cross the ford. Meanwhile the Wave Serpents pushed forward along the right-hand bank, their distortion fields rippling like a bow-wave before them. On the right two squadrons of Jet Bikes which had transferred across from the Eldar centre engaged the surviving Space Marine Bikes while the Exarchs pushed on to attack the Land Raiders. The Swooping Hawks charged the handful of Devastators holding objective 2, but in the heat of battle Jervis forgot to give orders to the Vypers deployed in the woods, so they were unable to move and wouldn't be able to fire until the advance segment!

Taking advantage of this oversight, vengeful Space Marine Assault troops, led by the Chaplain, leapt on the milling Vypers and engaged them in close combat. Further to the right, Blood Angel reinforcements advanced to support the beleaguered Devastators while the Titan and the Dreadnoughts manoeuvred through the woods to the left of the contested buildings and the Battle company's HQ charged into the combat at objective 2. On the left the Space Marine forces halted to engage the Eldar on first fire, with the exception of two detachments of Land Raiders which advanced out of the town and onto the hill on the extreme left in an attempt to engage the approaching Wraithguard and avoid the oncoming Wave Serpents.

In the combat phase a ferocious firefight broke out on the left. The Space Marine Land Raiders fired on the Eldar Phantom

but were defeated by its holo fields, only a single strand of the criss-cross web of lascannon fire struck home to damage one of the Phantom's wing-mounted weapons. Eldar Falcons and Tempests executed their special 'pop-up' attacks, rising above cover to lash at the Space Marines' Land Raiders, almost wiping out one squadron and badly damaging another.

The Blood Angels' Devastators replied by downing a squadron of Falcons, a Warp Hunter and two of the Tempests before the remainder sank out of sight again. The Terminators mowed down four squads of Spirit Warriors as they splashed through the ford and the Eldar Guardian squads around objective 5 punished a Space Marine Tactical detachment for remaining positioned on the hill without cover.

In a roiling melee in the centre the Vypers were almost wiped out, though not without cost to the Assault squads attacking them. On the right the Exarchs lost another stand to the Land Raider's fire before they ripped one of the Land Raiders to pieces in close combat. At objective 2 the combined fire of the Devastator squad and the Company HQ succeeded in killing only a single Swooping Hawk squad and the Blood Angels were destroyed in the subsequent close combat, leaving the objective firmly in Eldar hands. The Eldar Warlock on the right succeeded in paralysing the Space Marines' Titan with a Psychic Lock and the remaining Eldar troops started pouring fire into the helpless Titan, downing most of its void shields.

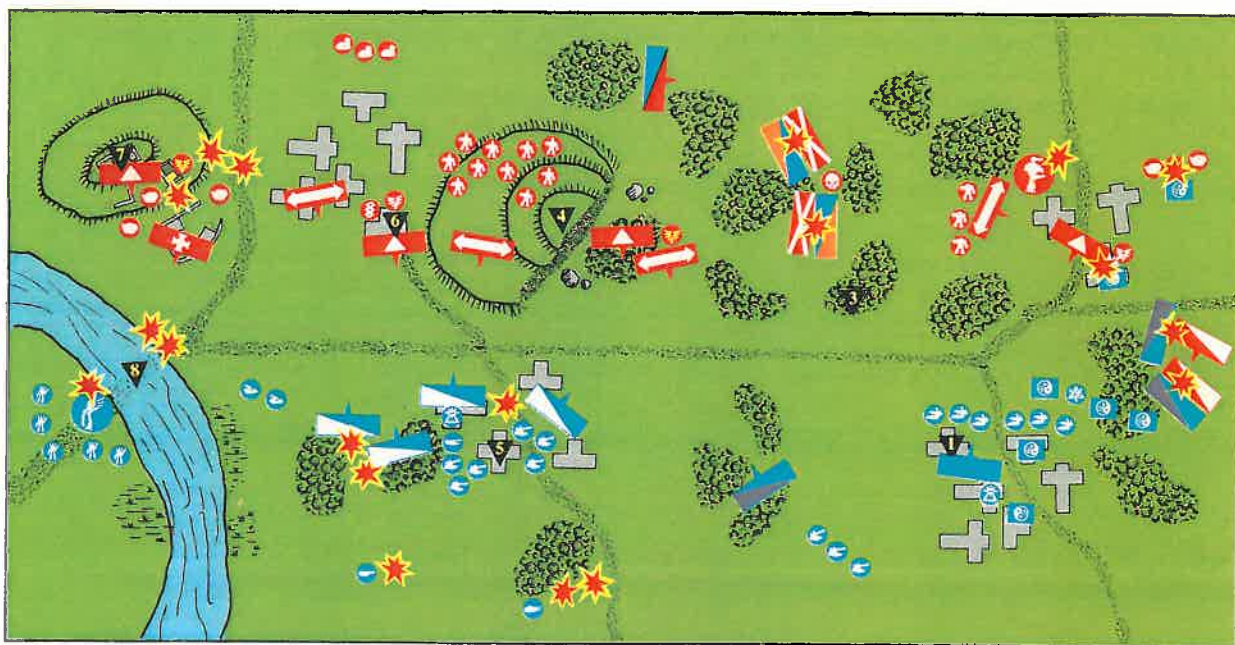

ELDAR ALAITOC CRAFTWORLD

| | | | |
|--|-----------------|--|-----------------|
| | Avatar | | Lascannon |
| | Harlequins | | Prism Cannon |
| | Warlock | | Vibro-cannon |
| | Aspect Warriors | | Guardian |
| | Tempests | | Shieldbearers |
| | Warp Hunters | | Vyper Jet Bikes |
| | Wave Serpents | | Jet Bikes |
| | Wraithguard | | Guardians |
| | Dreadnoughts | | Phantom Titan |

BLOOD ANGELS SPACE MARINES

| | | | |
|--|----------------|--|----------------|
| | Chaplain | | Dreadnoughts |
| | Medic | | Robots |
| | HQ Land Raider | | Vindicators |
| | HQ Units | | Whirlwinds |
| | Terminators | | Land Raiders |
| | Assault Det | | Land Speeders |
| | Tactical Det | | Bike Squadrons |
| | Devastator Det | | Warlord Titan |



Eldar Wraithguard storm across the river into the teeth of Blood Angels' fire – and die!



WAYNE ENGLAND

TURN 2 TACTICAL NOTES

FIGHTING IN BUILDINGS

Fighting close combats in buildings poses special problems. A clever opponent will move into the building to use its 'to hit' modifier to minimise the effects of defensive first fire. The easiest way to avoid this is to space the defending stands throughout the building to prevent attackers moving inside.

In the attack by the Swooping Hawks on objective 2 the Devastator squad and the HQ stands only killed one of the Swooping Hawk squads in spite of rolling a total of four attack dice (the HQ stand could also shoot in the first fire segment because it didn't move at more than its normal rate of 10cm). This was because Jervis sensibly moved inside the building increasing the score the Blood Angels needed from a 5 or 6 to a 7 (a roll of 6 rerolled and scoring 4, 5 or 6).

TURN 2 VICTORY POINTS TOTAL

Alaitoc Craftworld: 29 VP

Blood Angels : 29 VP

TURN THREE

The Eldar won the initiative and forced the Blood Angels to move first. The Space Marine Devastators on the right withdrew from the buildings into the woods, abandoning objective 2 completely. One detachment of Assault troops moved up to support the weakened Blood Angel right flank and a squadron of Land Speeders also arrived having transferred from the left. The remaining Space Marine Assault troops moved in to tackle the two surviving Vypers. On the left a Space Marine Tactical company launched an attack against the Eldar Guardians in the buildings, supported by the Devastators and the robots, which had finally reached the crest of the hill and objective 4.

The Eldar Jet Bike squadrons on the right swooped on to attack the Land Raider squadron while the Exarchs moved in to secure objective 2. The Striking Scorpions then charged in to finish off the handful of surviving Marine Bikes. A third squadron of Jet Bikes careened in to extricate the beleaguered Vypers and grab objective 3, left unattended by the Space Marine Assault troops. The surviving Eldar Prism Cannon swept out of the firefight on the left and moved across to try and reach the Space Marines' now vulnerable Warlord. On the right, the Eldar Phantom Titan waded to the midpoint of the ford establishing tight control of objective 8.

On the right, the Jet Bikes attacking the Land Raiders suffered sufficient casualties from the Land Raiders' first fire to finally break the entire company. They then failed their morale check

and were subsequently hammered by the Land Raiders in close combat. In the centre only one of the Vyper units broke, and although the remaining Jet Bikes and Vypers were badly battered by the Blood Angels' Assault troops, they inflicted sufficient casualties to break the Space Marine's Battle company. Fortunately for the Blood Angels only the Assault detachment failed its morale check.

On the left the Guardians switched their attention to picking off the Tactical squads which were storming towards them, but with only limited success. The Devastators surrounding objective 6 supplied some lethal supporting fire to their tactical brethren, downing four more Falcons and another Warp Hunter. A Land Raider was destroyed by the surviving Falcons, breaking the Land Raider company and causing the Land Raiders on the extreme right to go onto fall back orders when they failed their morale check.

Both the Phantom and the Warlord Titans fared badly on this turn. The Space Marine Warlord had its shields knocked down again and the Avatar hurled his Suin Daele damaging the Warlord's mind impulse unit. The Titan was then caught in a hail of fire as numerous shots from the Dark Reapers and Guardians gathered around objective 1, splattered off its heavy armour. The Phantom tried to dodge and weave through the combined fire of Terminators, Devastators and Land Raiders, but the pattern was too complex and inevitably the Phantom was hit. The Terminators struck first and damaged



ELDAR ALAITOC CRAFTWORLD

- | | | | |
|--|-----------------|--|-----------------|
| | Avatar | | Lascannon |
| | Harlequins | | Prism Cannon |
| | Warlock | | Vibro-cannon |
| | Aspect Warriors | | Guardian |
| | Tempests | | Shieldbearers |
| | Warp Hunters | | Vyper Jet Bikes |
| | Wave Serpents | | Jet Bikes |
| | Wraithguard | | Guardians |
| | Dreadnoughts | | Phantom Titan |

BLOOD ANGELS SPACE MARINES

- | | | | |
|--|----------------|--|----------------|
| | Chaplain | | Dreadnoughts |
| | Medic | | Robots |
| | HQ Land Raider | | Vindicators |
| | HQ Units | | Whirlwinds |
| | Terminators | | Land Raiders |
| | Assault Det | | Land Speeders |
| | Tactical Det | | Bike Squadrons |
| | Devastator Det | | Warlord Titan |



Blood Angels No 6 Tactical Company push forward to assault the town

the Phantom's holofields allowing the other Space Marine units to attack it more easily. The Phantom then suffered a crippling leg hit and its Power Fist was blown off in a gout of flame.

In the end phase the Space Marine Titan succeeded in repairing its damaged mind impulse unit but was still unable to shake off the Warlock's psychic lock.

TURN 3 TACTICAL NOTES

DESIGNATING TARGETS

When rolling attack dice you're supposed to designate the targets for all your dice before you measure range or roll. In particularly big games things can bog down with endless pondering about how to split up attack dice. To save time Jervis and I usually just indicate one or more target detachments and assume that each dice is being rolled against a separate target. In cases where there are more dice than targets, we specify where the extra dice are going to attack before we roll. When the Devastators fired on the Falcons in turn three, I picked the Falcons and the Warp Hunter as targets and specified two dice against each. I was lucky enough to score at least one hit on each and Jervis was good enough to have his usual misfortune and fail all his saving throws, destroying all four Falcons and the Warp Hunter!

CONCENTRATION OF FORCE

Concentration of force means exactly what it says - concentrate your troops so that you can apply the maximum amount of firepower against only a part of the enemy line. Lets take a hypothetical example. Two players have 10 Space Marines each. One spreads out in a long line right across the table. The other concentrates his men on one flank. Only 3 of the opponent's Marines are in range and can fire causing, say, 1 casualty. All 10 of the second player's Marines can shoot, and they cause 3 casualties, wiping out their opponents. By concentrating his force the second player has overwhelmed part of the enemy line and caused a 3-1 kill ratio!

Of course, concentration of force will be affected by other factors.

Sticking your troops shoulder to shoulder can be dangerous if your opponent has area effect weapons, for example, or you may have to spread out in order to capture widely separated objectives. However, you should aim to concentrate your force as much as you possibly can.

TURN 3 VICTORY POINTS TOTAL

Alaitoc Craftworld: 49 VP

Blood Angels : 32 VP

TURN FOUR

The Space Marines won the initiative and made the Eldar move first. To the Blood Angels' horror the hitherto-ignored Wave Serpents lunged forward and disgorged four troupes of brightly patterned Harlequins, who leapt forward to attack objective 6. The Devastator detachment was caught badly off balance, unable to defend itself, as it had been preparing to advance in support of the Space Marines' own attack.

In the centre the remaining Eldar Jet Bikes pulled back to surround objective 3 in an attempt to hold it for another turn, while the Swooping Hawks leapt across to aid the Jet Bikes by engaging part of the surviving Blood Angels Assault detachment. On the right the Howling Banshees and Striking Scorpions followed the Exarchs through the cover of the buildings towards the woods. The Fire Dragons also moved up into the buildings, trying to work their way round the immobilised Warlord Titan.

The Blood Angels pressed on with their attack against objective 5 on the left, storming in and engaging some of the defenders in close combat. On the right the Devastators provided covering fire as the Tactical detachment withdrew deeper into the woods. The Land Speeder squadron which had been moving across to reinforce the faltering right, was diverted to strafe the Eldar Jet Bikes surrounding objective 3. The Blood Angels also threw in the Chaplain and the single Assault squad which could extricate itself from the Hawks to engage the Jet Bikes in close combat.

The Eldar Guardians and Dark Reapers lashed the Warlord with fire again, scoring several hits. Although all the shots were aimed at the Titan's plasma reactor most were deflected by the reactor's armoured housing or flew wide, smashing into the Warlord's arms and destroying both its Gatling Blaster and Power Fist. A flashback from the Gatling Blaster then caused a temporary reactor shutdown to the Warlord and to add insult to injury the wreckage of the Power Fist span off and landed squarely on one of the Dreadnoughts nearby.

The Space Marines slackened their fire against the crippled Phantom as they lent more supporting fire to the attack on the town. Even so, the Phantom had its Pulse Laser blown off by the Terminators, who had narrowly avoided being fried by it on the two previous turns. The Blood Angels assaulting the town got off with remarkably light casualties, although the Tactical company's HQ was gunned down by Eldar first fire as it close assaulted a building. On the right the Devastators picked off some of the Aspect Warriors gathering in the buildings, but the Eldar still refused to be distracted and concentrated most of their fire on the hapless Warlord. The Space Marines retook objective 3 with a combination of Assault troops and the Land Speeders' lethal melta fire, wiping out the Jet Bikes and most of the Swooping Hawks in the process. But, in their moment of success, a distant battery of Eldar grav-mount lascannon blasted the surviving assault squads and killed the Chaplain.

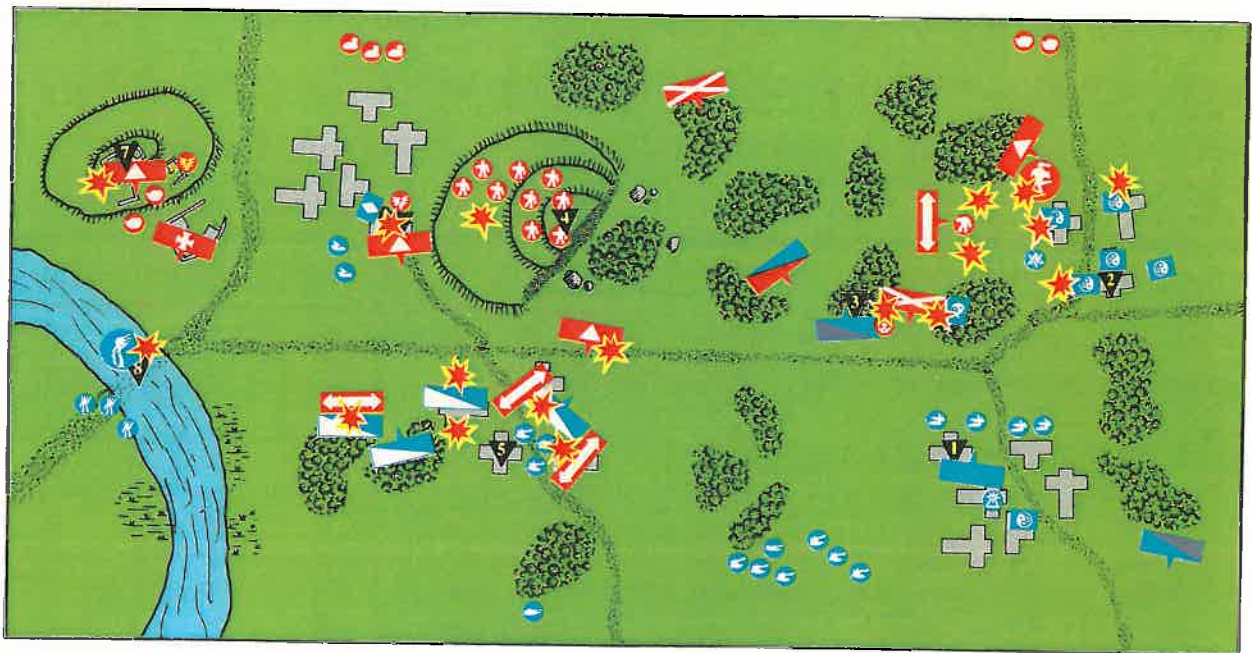

ELDAR ALAITOC CRAFTWORLD

- | | | | |
|--|-----------------|--|-----------------|
| | Avatar | | Lascannon |
| | Harlequins | | Prism Cannon |
| | Warlock | | Vibro-cannon |
| | Aspect Warriors | | Guardian |
| | Tempests | | Shieldbearers |
| | Warp Hunters | | Vyper Jet Bikes |
| | Wave Serpents | | Jet Bikes |
| | Wraithguard | | Guardians |
| | Dreadnoughts | | Phantom Titan |

BLOOD ANGELS SPACE MARINES

- | | | | |
|--|----------------|--|----------------|
| | Chaplain | | Dreadnoughts |
| | Medic | | Robots |
| | HQ Land Raider | | Vindicators |
| | HQ Units | | Whirlwinds |
| | Terminators | | Land Raiders |
| | Assault Det | | Land Speeders |
| | Tactical Det | | Bike Squadrons |
| | Devastator Det | | Warlord Titan |



A Blood Angels' Devastator Detachment from No 9 Company moves up in support of No 6 Tactical Company

On the left the Harlequins easily took objective 6 and killed the Medic and Devastator company HQ, though two Harlequin troupes were subsequently killed by fire from the remaining Devastators. The robots' autocannon finally found their mark and killed the Eldar Warlock who was rather foolishly standing closest in the building opposite. The Space Marines assaulting the town around objective 5 broke one detachment of Eldar Guardians and captured two of the buildings. The Space Marines Rhinos also overran a battery of lascannon in the streets and destroyed it.



In the end phase the Warlord finally shook off the psychic lock which had stopped it moving or firing for the past three turns. Unfortunately it failed to repair its reactor damage and remained helpless!

TURN 4 TACTICAL NOTES

MOVING INTO CLOSE COMBAT

When the Blood Angels made their desperate counter-attack against objective 3 the Assault squad could theoretically have simply jumped past the Jet Bikes and got closer to the objective. Why didn't they?

Close combat is one of the most complicated things you will do in a game of Space Marine, and it calls for a certain amount of common sense on your part when you interpret the rules.

Returning to our example, we say that when you enter close combat you should move straight into close combat by the shortest route. After all, this is only logical. The only exceptions to this are when your prospective opponent has already been engaged by another model or when you attack squads in a building. We also rule that models have to be able to actually physically touch their opponent - stacking models on top of each other is not allowed!

TURN 4 VICTORY POINTS TOTAL

Alaitoc Craftworld: 54 VP

Blood Angels : 41 VP

TURN FIVE

The Eldar player won the initiative and opted to move first. On the right the Aspect Warriors held back and stayed amongst the buildings until the Warlord had been safely dealt with. On the left flank, part of the Guardian War Host charged back to defend objective 5, the remaining Guardians going onto first fire. The handful of remaining Eldar Dreadnoughts crossed the river.

The Blood Angels threw all they could muster into the town, with the handful of surviving tactical squads charging objective 5. The Land Speeders sped up the centre, the Devastators which had advanced out of the woods on the previous turn, charged into the town and even the Whirlwinds moved onto the hill to give direct barrage support. On the right the Tactical detachment moved into the woods surrounding objective 3, with the Devastators once again covering their retreat.

The combat phase opened with the Eldar Dark Reapers hammering at the Warlord again. Their missiles scored four hits, three of which struck the reactor. The Warlord's battered armour finally collapsed under this weight of fire, the reactor split open and the mighty Titan was vapourised in an all-consuming plasma meltdown. To everyone's horror the ball of white fire expanded to engulf a massive area; scouring clean the nearby buildings and woods of both Eldar Aspect Warriors and Blood Angels Devastators!

The Terminators cut down the last of the Eldar Dreadnoughts on the river bank. The Space Marine Land Speeders ran across the surviving Eldar Tempest and two of them were blown apart by its lasers. The Robots turned on the Harlequins and sprayed them with autocannon fire but to no effect. The Devastators ignored the Harlequins and gave deadly accurate supporting fire to the assault on the town. One of the few surviving Land Raiders succeeded in punching a shot into the Phantom's reactor housing, but only caused it to temporarily shut down.



The Space Marine Tactical squads attacking objective 5 did all they could and killed everything they could reach. However, a single Eldar Guardian squad eluded their grasp and by denying them the objective made the final victory point total for this turn – Alaitoc Craftworld: 71, Blood Angels Space Marines: 61.

In the event of both players exceeding the required number of victory points in the same turn the game is a draw, with both sides armies considered too shattered to continue the battle.

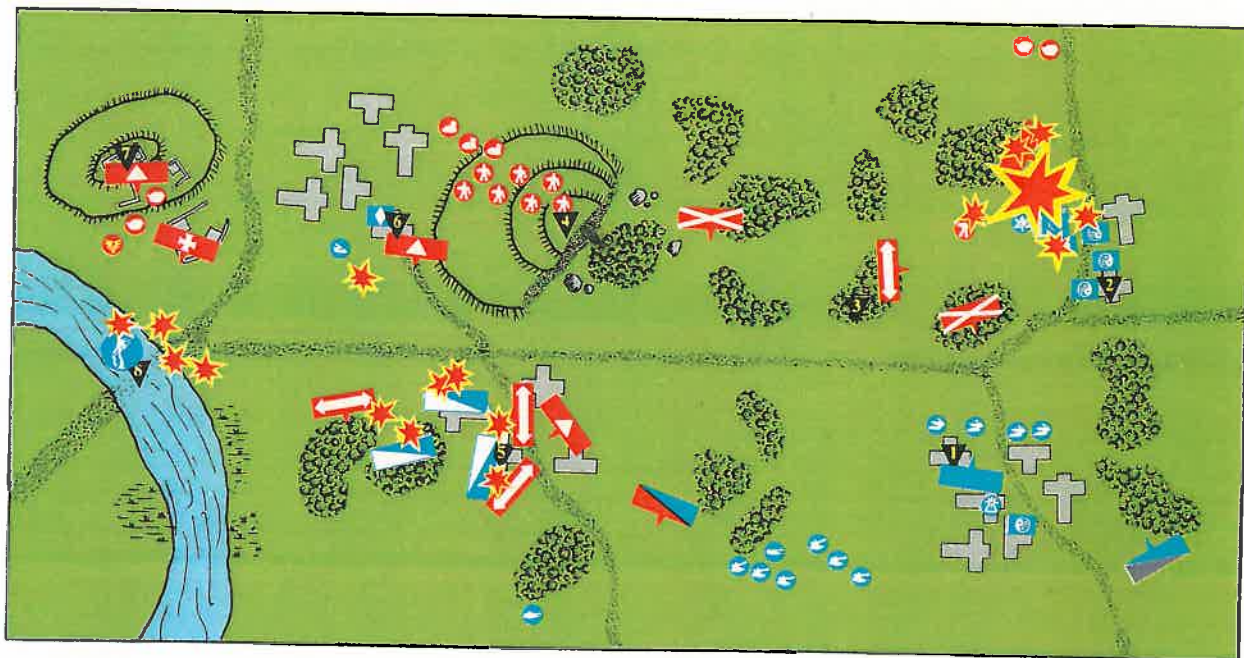

ELDAR ALAITOC CRAFTWORLD

- | | | | |
|--|-----------------|--|------------------------|
| | Avatar | | Lascannon |
| | Harlequins | | Prism Cannon |
| | Warlock | | Vibro-cannon |
| | Aspect Warriors | | Guardian Shieldbearers |
| | Tempests | | Vyper Jet Bikes |
| | Warp Hunters | | Jet Bikes |
| | Wave Serpents | | Guardians |
| | Wraithguard | | Phantom Titan |
| | Dreadnoughts | | |

BLOOD ANGELS SPACE MARINES

- | | | | |
|--|----------------|--|----------------|
| | Chaplain | | Dreadnoughts |
| | Medic | | Robots |
| | HQ Land Raider | | Vindicators |
| | HQ Units | | Whirlwinds |
| | Terminators | | Land Raiders |
| | Assault Det | | Land Speeders |
| | Tactical Det | | Bike Squadrons |
| | Devastator Det | | Warlord Titan |



The Space Marines' Warlord Titan is destroyed in a spectacular reactor meltdown

TURN 5 TACTICAL NOTES

SUPPORTED ATTACKS

As we mentioned earlier, close assaults can often be costly unless you resort to 'ambushing' lone enemy units. But often you have to conduct close assaults in the middle of the enemy lines in order to capture objectives. So how do you do it?

By using supporting units on first fire to shoot up any enemy units near the close combat, you can try to destroy enough of the enemy to cut down your casualties. Even if you fail, you might annoy your opponent enough to force him to fire back. A further refinement is the use of a second wave of advancing troops to mop up survivors of the close combat and give support fire. The Space Marines assault on objective 5 is an example of a supported attack (just not a very successful one).

MAINTENANCE OF AIM

So why did the Space Marines continue their attack on objective 5 right to the end of the game? The answer is maintenance of aim. Maintenance of aim means 'make a plan and then stick to it'. If you are going to win any games at all you must have a plan. Keep it simple, and make sure that you have it clear in your mind before the game starts. Then, barring an absolute major disaster, stick to your plan through thick and thin. If you don't you'll find yourself simply reacting to your opponent's moves, which means that you have started playing for a draw rather than going for a win!

THE RIGHT TOOLS FOR THE JOB

In Space Marine, certain kinds of troops are usually good at one kind of job, but almost useless at another. To win battles, one of the most important skills you must learn is how to deploy the right units, in the right place, at the right time, in order to accomplish the task in hand. In other words – make sure that you have the right tools for the job.

An example of how important this is, can be seen in Jervis's poor use of his Prism Cannons. The Prism Cannon is the Eldar equivalent of the Imperial Volcano Cannon – one hit can destroy almost anything, even a Titan. At the start of the game Jervis had his Prism Cannons positioned on his left flank. What he *should* have done, was transfer them straight away to the right where they could have joined in the attack on the Warlord. His failure to do so, meant that the Titan survived for five turns under a hail of fire, when a single hit from a Prism Cannon could have finished it off. Destroying the Warlord on turn four would have won the game for the Eldar, and so this proved to be a very costly mistake indeed.

TURN 5 VICTORY POINTS TOTAL

Alaitoc Craftworld: 71 VP

Blood Angels : 61 VP

CONCLUSION

So a draw, with laurels going to Alaitoc for being furthest past the finishing line. We'd wanted an apocalyptic battle and we certainly got one. Losses on both sides were horrendous and each of us had only a handful of unbroken forces left by the end of the game. When it was all over, Jervis and I both sat down, and prepared a commentary on our performances, with the lessons learned and future plans.



BLOOD ANGELS DEBRIEFING (ANDY CHAMBERS)

Hmmm. So, where did I go wrong? I've spent a long time in the Reclusiam chastising my unworthy self and contemplating the reasons for my lack of success. So that you can learn by my follies, I've summarised my reasoning for each one and the lesson it taught me.

Given Jervis' actual deployment on the day I think I would have been better off with the plan that involved piling everyone up my right flank. This would have left all those Aspect Warriors plodding down the table to try come to grips with me, while I concentrated my entire force on wiping out the Wraithguard and the Guardians. Of course, I would have been 'bounced' by the Jet Bikes from the centre, but it seems to me that Jet Bikes are pretty fragile and get used up quite quickly, so I think they would have caused limited damage. So much for what might have been, what about what was?

Given a lack of hindsight for a moment I think dismissing the idea of going up one flank exclusively was wise. My huge mistake was not thinking about the deployment of my units enough. For example the Terminators ended up pinned down by the Wraithguard in a small settlement on an extreme flank position – they should have been centrally placed either to lead the attack on objective 5 or to plug gaps and bolster up the line. Their short ranged lethality and high close assault factor should have been put to good use in close terrain not stuck out in the most open area of the table!

The Vindicators which were 'ambushed' by Jet Bikes before they got anywhere should have headed into the Terminators' position, ready to blast away at objective 5 and not been left stuck in the middle of a wood!

Things like these are minor details of course, but a plan is only ever as good as it's execution. Throughout the game I continually found myself struggling to redeploy troops into different areas to fend off the Eldar and stabilise my line. This forced me into a position where I was meeting the Eldar on their terms and responding to threats as they occurred instead of moving decisively and making ground. Its worth noting that I didn't capture any objectives after the first turn, I only just managed to recapture objective 3 and prevent myself losing entirely on turn 4.

So what did I learn?

1] Not thinking at the start of the game and randomly stuffing your troops into battle in a big long line is not a good idea.

In the early stages of the game I made the mistake of only moving up at advance rate on a few occasions. The few extra shots I actually got for this didn't really pay off: I would have been better off using charge orders to get my troops into the right positions from the word go. This tendency to use advance orders too much also delayed my attack on objective 5, a delay which increased casualties and caused the attack to run out of time on the very threshold of success.

2] Decisive action, even if it isn't the right action, is preferable to inaction. Bimbling around too much is not a good idea.

Another thing I did was fail to use the Space Marine Rhinos. I always stick to a golden rule of never, never keeping troops inside Rhinos after the first turn's movement, because any opponent that's awake will snap at a chance of wiping out a Rhino and two infantry squads with one shot. But in this game I think the risks would have paid off, several units spent quite some time tramping towards the enemy when I could have safely kept them mounted in Rhinos for a much swifter deployment. The devastator and tactical detachments in the woods in the centre would definitely have been better off charging forward in their Rhinos for a couple of turns before leaping out.

3] Though it's good to use guidelines about good tactics every game is different and should be viewed as such, not as an exercise followed through by rote. Mindlessly sticking to 'Golden Rules' is not a good idea.

I felt overall that I fought reasonably well but my poor deployment led to me constantly fighting an uphill battle against Jervis' better positioned Eldar. I was surprised just how far the ragtag assortment of tactical squads I threw in to attack objective 5 got, though I must say I was lucky. My Titan? Well I think the less said about him the better, though I do think that even if he had escaped the Warlock's tricks earlier he probably would have copped it from something else – it was just one of those days. Still, I'll be back.



ALAITOC DEBRIEFING (JERVIS JOHNSON)

Curses! Victory was in my grasp, but I let it slip away. If I had just paid a little bit more attention to what I was doing I could well have pulled off a win on turn 4.

So where did I go wrong?

Well, I still think that my plan was sound and I wouldn't change that at all. My deployment was perfectly acceptable, though knowing what I do now I would have placed the Eldar's very long range weapons (such as the Tempests and new Prism Cannon) closer to the centre of the table where they could have covered both flanks rather than just one.

One point that was driven home to me was the need to keep Windriders operating as a large group which can overwhelm an isolated part of the enemy line and then move on. In this game I once again succumbed to the temptation to scatter them all over the battlefield, with the result that they were wiped out in penny packets. The one and only game in which I remembered to use them 'en masse' they charged across the table, caught a Space Marine detachment and some Vindicators in the process of deploying, wiped them out in close combat, all on the first turn, and then proceeded to rampage around my opponent's rear areas causing panic and destruction wherever they went. Now that's the way to use Windriders.

However, my real failure was allowing my concentration to slip about half way through the game. It's easy to do this, especially in a large game, especially if you are doing well. The most notable examples of this lapse was my failure to give orders to the Vypers on turn 2 and the Harlequins (Wave Serpents) on turn 3. This spelt the doom of the Vypers as it allowed Andy's Assault detachment to catch them, and it also meant that I ended up diverting my reserve Jet Bikes to the centre rather than the flanks where they might have been of more use. In the case of the Harlequins it slowed down their assault on objective 6 which in turn allowed the Space Marines around that objective an extra turn's fire against my Falcons, with suitably devastating results (no pun intended). Other foolish mistakes that could have been avoided were moving my Phantom Titan too close to Andy's Terminators so they were able to shoot it up, and failing to get my Prism Cannon and lascannon into a position where they could attack Andy's Titan.

On a more positive note I learnt valuable lessons about the new Eldar Wave Serpent, Prism Cannon and Warp Hunter.

The Wave Serpent is an excellent assault vehicle, and this is what you should use it for. It is easy to get side-tracked into thinking of interesting ways of firing off its distortion fields; try to remember that their primary function is to protect the Wave Serpent, not kill the enemy! The Prism Cannon fills the niche occupied by the Shadow Sword in the Imperial army: it is an awesome anti-Titan weapon. If you include any in your army you should manoeuvre them so that you can use them to blow away enemy Titans first, use them against enemy vehicles second, and enemy infantry last of all. The Warp Hunter has to be used against large concentrations of targets due to its inherent inaccuracy but it is not affected by the targets cover, which makes it an excellent choice for winking out infantry massed in buildings or woods. I can't wait to try out the Warp Hunter against an Imperial Guard or Ork army!

Turning my attention to the other side of the table, I was surprised at how cautious Andy's moves were. On the whole I got the impression that he was reacting to my plan rather than following one of his own, and he certainly seemed to act very defensively throughout the game, which is not like Andy at all. The only exception was his sudden charge towards my War Host and objective 5 which I must admit caught me completely by surprise, but which I doubt would have made much difference even if he had captured the objective as it occurred too late in the game. Where Andy excelled, as ever, was in his concentration and attention to detail, the area where I really blew it. This probably doesn't show up all that well in the broad sweep of a battle report, but I've been on the receiving end enough times now to know that Andy very, very rarely makes foolish mistakes like forgetting to give a unit its orders for the turn! In this game, as in so many others, Andy's thoroughness made all the difference between victory and defeat.

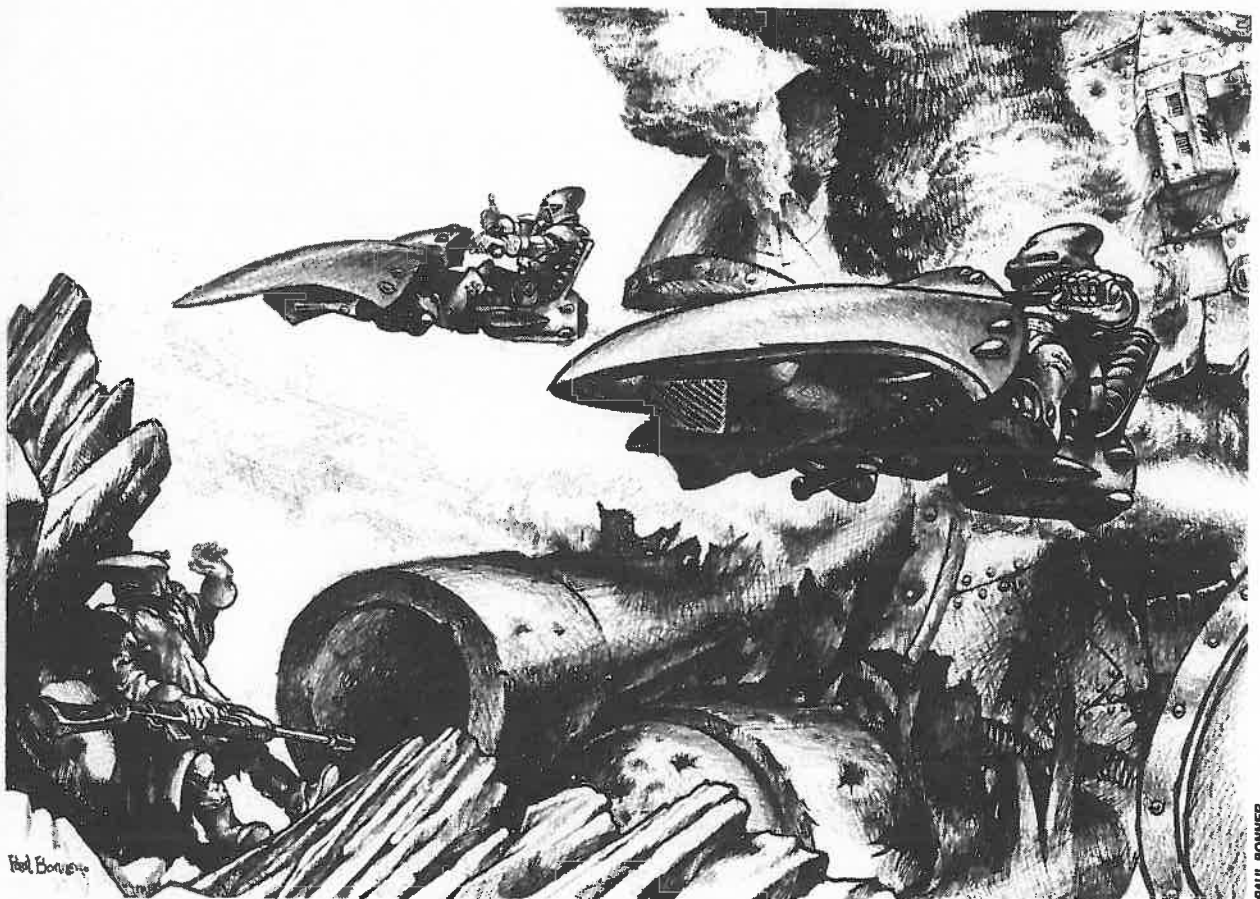



EAVY METAL

In the Space Marine battle report featured elsewhere in this issue, several new Eldar vehicles and weapons are used in battle for the first time. Tim Prow explains the techniques he used to achieve the brilliant results seen in the photographs below.

The Wave Serpent, Prism Cannon and Warp Hunter are all specialised Eldar attack vehicles which make deadly additions to an Eldar force.

The main bodies were first painted with a mix of Sunburst Yellow and Blood Angel Orange, then highlighted with Sunburst Yellow and Skull White. To draw even more attention to these specialist vehicles, I concentrated most of my efforts on the focal point of each model.

THE WARP HUNTERS

In the case of the Warp Hunter, the most important part is the cannon, so I gave this a base coat of Chainmail and then highlighted it with Mithril Silver to produce a bright, shining metallic effect.

THE PRISM CANNON

The rear part of the Prism Cannon was painted to represent blue crystal. To begin with I painted on a base coat of

Enchanted Blue and then highlighted by adding a mix of Skull White and Enchanted Blue. The edges were given a thin highlight of pure Skull White to make them really shine.

THE WAVE SERPENTS

The Wave Serpent was given a base coat of Moody Blue mixed with Chaos Black and then highlighted by brushing with Skull White added to Moody Blue. The focal point of this model is definitely the prow, so I painted a wave design onto this area to emphasise it. The stylised waves fitted perfectly and were very easy to produce. Using a fine brush and some Skull White (thinned down slightly with a drop of water), I painted a line of wave shapes down the side of the prow to form the crests of the waves. If you look at the painted models you'll see that the waves get smaller in size towards the rear of the vehicle, leaving the crests the same distance from the top edge of the prow. Varying the size of the waves in this way gives an effect of movement. The rest of the wave is then filled in with Skull White and finally, a touch of Electric Blue is added at the base of the waves.



ELDAR WARP HUNTERS



ELDAR PRISM CANNON



ELDAR WAVE SERPENTS



The new Eldar decals are perfect for adding decoration and symbols to all parts of your Epic army. Each pack contains several different sizes of decals for each Craftworld symbol, so you'll be able to fit them onto any of your vehicles. They also come in several different colours, so you'll always be able to find one that shows up well against the main colour.

To show which Craftworld they belonged to, I added an Alaitoc rune to the Wave Serpent and the Prism Cannon. First I carefully cut round the rune, making sure to leave a few millimetres clear around the edges. It was then soaked in water for a couple of minutes until the decal moved freely on the backing paper. To apply the transfer onto the model I held the backing paper next to the area where I wanted the design to go and carefully slid it off using the tip of a brush. It's a good idea to make sure that the area that's receiving the transfer is slightly wet as this allows for re-positioning. When it's in the correct place, carefully remove any excess water with a piece of tissue.



THE ELDAR AVATAR

THE AVATAR

The Avatar model allows you to have the Eldar God of War, Kaela Merisha Khaine, leading your forces into battle.



The Avatar's smouldering, molten armour is represented by painting it a bright, fiery red. I first gave the model a base coat of thinned down Blood Angel Orange, followed by a wash of Red Ink, and highlighted with Sunburst Yellow.

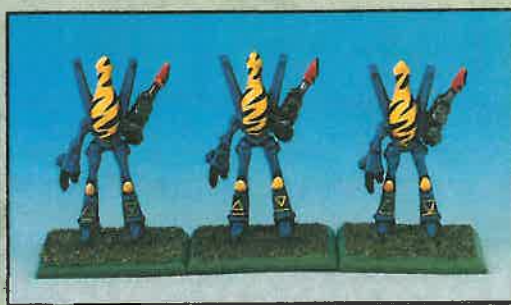

ELDAR DREADNOUGHTS

THE ELDAR DREADNOUGHTS

I then painted the inside of the cloak a deep purple colour so that the body would really stand out. For this I used a mix of Fire Dragon Crimson and Chaos Black.

The Eldar Dreadnoughts are from the new Epic Stompers plastic box set. I painted the bodies in Enchanted Blue highlighted with Skull White and finally yellow runes were added to the legs. Then I painted the heads Sunburst Yellow and the tiger stripes were painted in Chaos Black, using a fine brush.



AN ELDAR PHANTOM TITAN

MIKE McVEY'S ELDAR TITAN

The new transfers were also used on the Eldar Titan. Mike painted a white circle onto the back of the Power Fist before the yin-yang decal was applied. This makes the clear half of the transfer appear white. The Titan infinity rune was applied to the forehead and the Alaitoc horned sword was added to the leg. Mike then shaded and highlighted the transfers to give them a little more depth.

The whole of the Titan was given a base coat of Bleached Bone, mixed with a little Snakebite Leather to deepen the colour. When this was painted over a clean white undercoat, the resulting colour becomes deep bone, so all you have to do is add the highlights. These were created with a mix of Bleached Bone and Skull White. More Skull White is added to the mix as the final highlights are applied so that the very last highlights are pure white. All of the edging round the bone areas were first painted Chaos Black and then the raised surfaces were painted white. This gives the bone colour a black surround to make it stand out. When the white was dry it was given a coat of Go Fasta Red and highlighted with Blood Angel Orange mixed with Skull White.

All of the metallic areas on the Titan were painted with some paint samples that Mike is trying out at the moment, and if we like them we could be bringing out a Metallic Paint Set in the near future. From the few models that Mike has painted with them so far, they seem to be really good and should prove to be an invaluable addition to any pallet.



Permission to photocopy for personal use.
Copyright © 1991 Games Workshop Ltd.
All rights reserved.

GAMES WORKSHOP®

NEW STORE

GAMES WORKSHOP - BALTIMORE
714 YORK RD
TOWSON, MD 21204

HOW TO GET THERE.

From the Baltimore beltway (I - 695) take York Road South (exit 26). The store is on the right-side of the road, approx 1 mile from I-695, just past McDonald's

OPEN NOW!

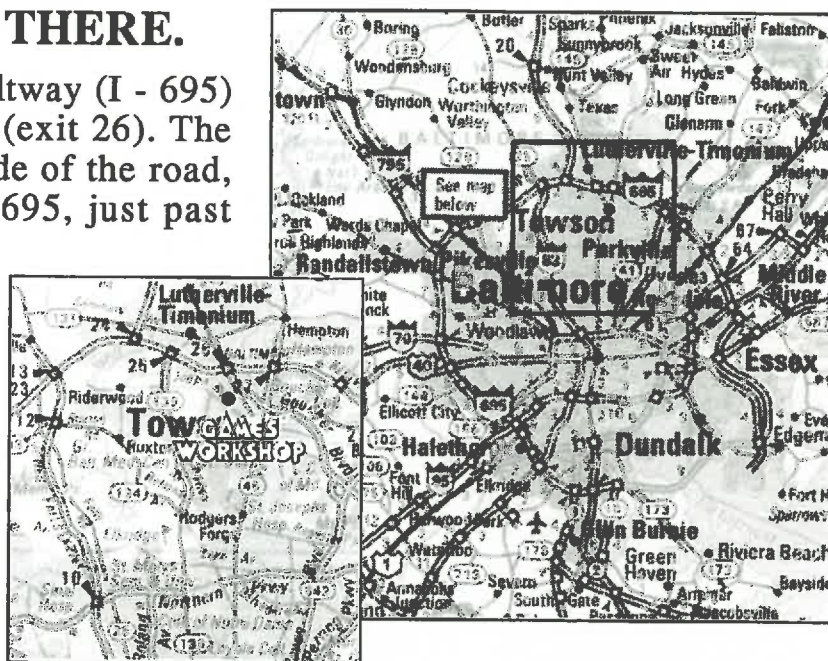

ARMIES OF THE IMPERIUM

IMPERIAL GUARD COLOUR SCHEMES

Following the dark days of the Horus Heresy, when Space Marines fought fellow Space Marines and the whole Imperium was torn apart by conflict, the victorious commanders of the Emperor sat down together to draw up a new galactic order, laying the foundations upon which the Imperium of the 41st millennium is built. In particular, and after a great deal of discussion, they produced the great tome of ancient military wisdom known as the Codex Astartes.

THE CODEX ASTARTES

Many of the most brilliant minds of the age contributed to the Codex Astartes. It describes not only methods of fighting wars, but also deals with such diverse elements as organising troops, establishing supply lines, clothing and feeding troops, subterfuge and espionage, and of course, countless tactics and ploys to confound the opposing commander. With such brilliant minds as the Space Marine Primarchs Leman Russ and El' Jonsen offering sagely advice, as well as the practical wisdom of the great Imperial Guard commander General Tybour, the Codex Astartes has always been regarded as an essential part of every young officer's education. Every Imperial officer is familiar with its contents, and its many precepts and ideas form the basis for much lively debate. Because it is presented as a series of discussions and ideas by the most advanced military thinkers of its day, not as a strict code of practice soon to become out of date, the book remains

fresh and valid ten thousand years after it was written. Much of its content is contradictory or inconclusive, representing different aspects of military practice, and this is what makes the volume an eternal source of inspiration to military commanders whatever their personal inclinations.



The Imperial Guard is a vast fighting force, and its leaders vary in ability from the most talented genius to the dullest functionary. The teachings of the Codex Astartes provide a minimum standard, enabling the least able to command in an effective, if uninspired way. Of course, an able commander may rise above this level, and the best commander knows exactly when to apply the ancient wisdom of the Codex and when to literally throw the book away. Such commanders are rare, but over such a vast span of time there have been many names to brighten the annals of Imperial history: Foch, Born Tahal, Castrokali, and many other heroes of the Imperium.

The Codex Astartes has much to say on the subjects of troop organisation, uniforms, colour schemes, and camouflage. Such things are important because only a well ordered and enthusiastic force can fight at its best. Naturally there are practical details to consider, such as the best type of camouflage to provide the best chance of avoiding enemy fire, unit markings to enable commanders to see where troops are, and banners for leaders so that troops under their command can identify their officers.

The following sections illustrate organisational and other markings used by the Imperial Guard and are taken from examples described in the Codex Astartes. The colour schemes and camouflage details provide sufficient combinations of colour and pattern to afford protection in almost any fighting environment. Although these are the most common colours and schemes, they are not the only ones by any means, as it is up to the commander to decide on the overall schemes for the force.

In practice of course, troops often have to make do with vehicles hastily painted, or even equipment transferred from another warzone and already painted a certain way. Some Guard regiments have traditional, famous and immediately recognisable schemes of their own which are completely different to those shown. This variety enables the ambitious painter free rein to invent new schemes, just as confident battlefield commanders do.

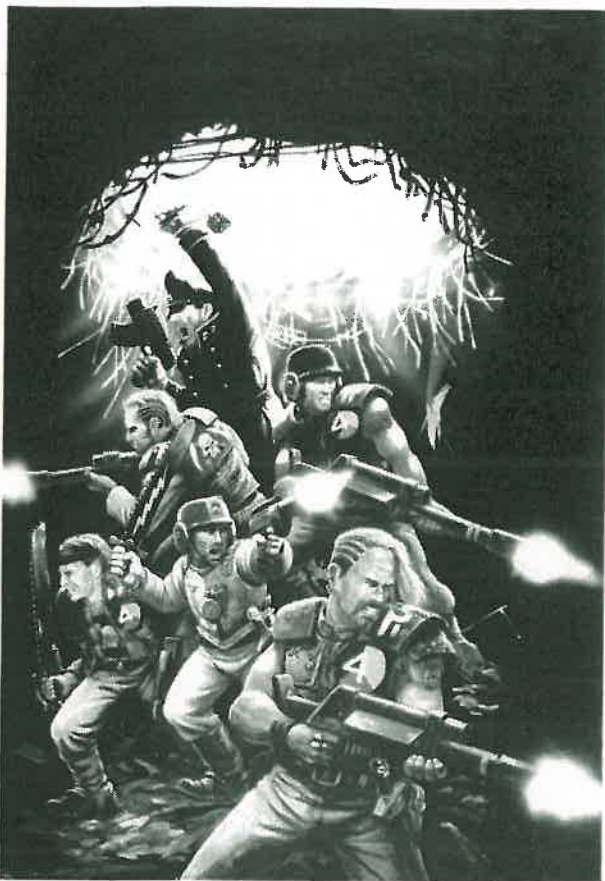

DAVE GALLAGHER

THE REGIMENT

The regiment is the largest formation in the Imperial Guard. It consists of a number of companies, and as a rule the entire regiment is recruited from one world. The following pages illustrate some of the colour schemes and markings used by tank and artillery companies.

PAINTING DETAILS

All of the tanks and vehicles shown were painted using the same technique. After undercoating, the models were given a base coat of the chosen colour, making sure that this covered properly without any patchiness. Once properly dry they were lightly drybrushed with either a mixture of Skull White and the base colour, or a special colour as explained in the description below. All of the tracks and guns were painted Chaos Black and then drybrushed with Boltgun Metal and Mithril Silver.



CODEX COLOURS

The 12 colours shown over the next page were all mixed from Citadel paints and the chart below describes how we achieved the final results. The exact shades do vary as you might expect in a warzone, with paint applied over different surfaces and allowed to fade or dull to various degrees before repainting.

BATTLE GREEN: This neutral green colour makes ideal camouflage in rural zones with temperate climates where the light is soft and the terrain either wooded or consists of pasture or prairie. Battle Green is mixed from Ghoulish Grey, Goblin Green and Chaos Black.

FORGE BRONZE: This is a highly reflective finish designed to protect the vehicle against excessive solar radiation or other harmful atmospheric effects. It is a common finish amongst Titan Legion ground forces, hence it is named after the Forge Worlds of the Adeptus Mechanicus. To make it mix Shining Gold, Bolt Gun Metal and Brown Ink. Highlight with Shining Gold.

FIRE ORANGE: Fire Orange is excellent camouflage on desert worlds which have a strong orange mineral oxide base. It is quite a bright colour but blends in well in hot, sunny, fiery coloured terrain. Use Blood Angel Orange with a touch of Red Gore – a spot is enough. Highlight with Sunburst Yellow.

ASH WASTE: The light grey/green colour blends well against drifts of mineral waste found in ash deserts as well as other light-saturated desert environments. To make Ash Waste mix Rotting Flesh and Skull White.

NIGHTWORLD: This is a favoured colour in poorly lit worlds as it reflects little light and blends well against caverns and rocks. To make Nightworld Blue mix Moody Blue and Chaos Black. Highlight with Enchanted Blue.

JUNGLE GREEN: As its name implies this is a colour designed to blend in with lush jungle scenery, although it also merges into darker forests too. It is also used on desert worlds with a strong green copper oxide sand. Mix the colour from Woodland Green and Chaos Black. Highlight with Goblin Green.

CODEX GREY: This colour is suitable for most environments and is especially effective in urban ruins, rubble and dust. We've used Codex Grey for our Leman Russ Company. To make Codex Grey use Elf Grey and mix in a little Chaos Black.

SULPHUR DESERT: This dark yellow colour provides excellent camouflage against sand, yellow oxide, and sulphurous terrain. To make it, add a spot of Orc Brown to Sunburst Yellow.

APOCALYPSE RED: Red is a very strong colour, but it works well on worlds with dark red iron oxide soils, red skies, and spectacular volcanic features which bathe the terrain with ruddy light. To make Apocalypse Red, mix Blood Red and Blood Angel Orange. Highlight with Bad Moon Yellow.

POLAR WHITE: This is a scheme designed to blend into frozen wastes such as ice and snow. It can also be used on some very light coloured mineral deserts, especially salt flats. Make Polar White by mixing Elf Grey and Skull White. Highlight with Skull White.

STRIKE GREEN: This is a light shade of yellow/green which is favoured on sun-drenched worlds with open vegetation. It is also the colour used for most artillery pieces. Strike Green is mixed from Striking Scorpion Green and Snakebite Leather.

HORIZON BLUE: This is a pale blue-grey colour which reflects the background colour of the sky and is therefore known as Horizon Blue. It is surprising how effectively this works across open territory. Mix this colour from Space Wolf Grey and Enchanted Blue. Highlight with Space Wolf Grey.

CAMOUFLAGE

The Codex Astartes discusses the effects of different patterns and how stripes or patches of various contrasting colours can be used to break up the shape of a vehicle and effectively disguise it. Not only does this make a vehicle harder to see at a distance, but even at short range it means the vehicle becomes a harder target to hit because it is difficult to judge its distance and the direction it is moving in. Although the Codex illustrates some specific patterns, it is the principle of using shapes to disguise the underlying vehicle which is important.

The examples shown over the page are particularly favoured patterns. They have been reproduced in a combination of two or more colours, but you can combine any colours to produce a suitable effect - it is the pattern itself which is important not the colours. The patterns can also be varied. For example you can twist any of the patterns round to fit the vehicle's shape, and you can add more stripes or patches if the vehicle is larger or longer. Another variation is to add edging colours to the stripes and patches. These edging colours can form complete borders along one or both sides of a stripe, or they can be broken, as shown on the jagged example overleaf.

Even though each of the patterns shown is different, the technique for painting them is basically the same. The underlying light colour is applied first to the whole tank and then the overlying colour is applied in the chosen pattern. It is important to paint the pattern so that it looks attractive and that the areas are visually balanced. If the basic scheme is a striped camouflage, the first stripe is painted on from one of the vehicle's rear corners to the opposite front corner, then the other stripes are applied evenly spaced to either side of this so that they look balanced. Don't try and paint on too many stripes or the shape of the tank will be too well hidden and the model will look less attractive. The schemes shown in the examples use two or at the most three colours. You can add more, but on the whole it is best to avoid this as the result often looks messy and confused.

MARKINGS

The painted examples have company, squadron and other markings painted on. This requires considerable patience, especially for the more complex shapes. Of course you don't have to include all these markings if you prefer not to - they are often obliterated from vehicles in the field, so there is no reason why you should feel obliged to include them. Citadel will shortly be producing a new transfer sheet based on these designs. On the larger tanks there is plenty of room to apply transfers, but on some of the smaller vehicles it may be necessary to file a small area flat to accommodate the design. We found this helped when painting some of the markings too, and doesn't detract from the appearance of the model at all

FLAGS AND CONVERSIONS

The flags were made from paper with the designs painted on. The completed flags were wrapped around a flag pole made from wire (we used a pin, but any rigid wire will do fine). To fix the flags in place we used superglue to fasten the poles to a suitable anchorage point. In some cases we drilled a hole to fasten the pins more securely.

Attaching a flag is simplest conversion there is, but there is no need to stop there if you feel confident enough to try something more ambitious. Opening hatches and putting in commanders is an obvious and attractive conversion. We used a fine saw to slice off the turret hatch on our Lemman Russ Company HQ tank. If you're careful, the same hatch can be re-glued in an open position - otherwise use a circle of card or plastic. The model is simply an Imperial Guard model cut at the waist and glued into position. You don't have to do this to your HQ tanks, but it does help to make them that bit more special.



JOHN BLANCHE

COLOURS

The 12 core vehicle colours recommended by the Codex Astartes are shown below on Leman Russ battletanks. Commanders in the field often devise their own schemes, but the ancient wisdom of the Codex Astartes is highly respected and most commanders rely heavily upon the sound words of its authors.



BATTLE GREEN



FORGE BRONZE



FIRE ORANGE



ASH WASTE



NIGHTWORLD



JUNGLE GREEN



CODEX GREY



SULPHUR DESERT



APOCALYPSE RED



POLAR WHITE



STRIKE GREEN



HORIZON BLUE

CAMOUFLAGE

The Codex Astartes contains a whole section devoted to the art of camouflage and illustrates many vehicle camouflage patterns of which the 8 most effective are shown below. The camouflage schemes are patterns only, the colours may vary.

ZIG-ZAG



Y-STRIPES



PATCHES



STRIPES



WAVY STRIPES



BANDS



JAGGED STRIPES



JAGGED STRIPES WITH INSETS

The vehicles illustrated are examples of camouflage patterns applied over various standard colours. In practice the combinations of colours differ and the patterns themselves inevitably vary as they are applied. The patterns may be twisted round so that stripes run the opposite way for example, and the number of stripes or patches are sometimes varied to suit the local terrain or the shape of the vehicle. It has been known for commanders or crews to superimpose two camouflage schemes together, or to add smaller patches, stripes, or other features.

COMPANY MARKINGS

Each Imperial Guard Regiment is made up of many individual companies. Tank and mobile artillery companies are distinguished by coloured bands consisting of a light broad band with darker inner band as shown on the examples below. This identifying banding is painted in a convenient position to aid recognition in combat. The side armour is often treated in this way and the design may also be repeated on the turret and frontal plate.

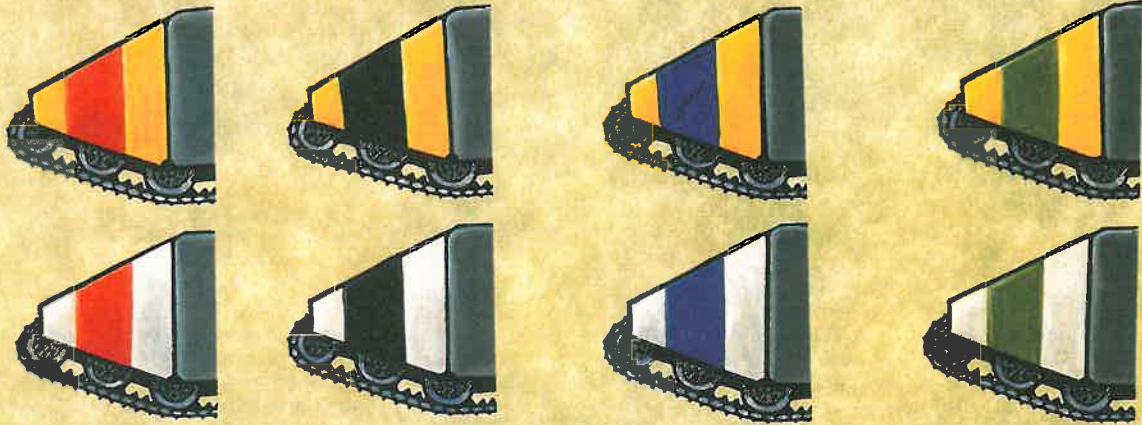

SQUADRON MARKINGS

Every company has its own distinctive badge which is carried by every tank in the company. Every tank squadron - usually three tanks - carries its company badge but in a distinctive colour - for example red for the first squadron, blue for the second, yellow for the third. The actual colours are up to the individual company leaders and are likely to be changed if a new colour scheme is adopted for a fresh campaign. The important thing is that the colours show up well enabling the squadrons to be identified by the company commander. Company commanders have their own tank which is always readily recognisable by one or more means. It is usual to paint the turret red and also to carry a flag displaying the banded companies marking on one side and the badge on the reverse.



I II III IV V VI VII VIII IX X XI XII 1 2 3 4 5 6 7 8 9 10

A selection of Imperial Guard squadron markings plus identification numbers sometimes used to identify individual vehicles in a company.

LEMAN RUSS COMPANY

This company consists of three squadrons plus a commander and demonstrates the use of the colour schemes and various company markings. The tanks are codex grey with red over white company markings producing a distinctive banding along the side armour.

The company badge is a star over a square patch and in this case the star colour changes to indicate the three different squadrons. Within each squadron every tank has distinctive barrel markings - this enables the squadron HQ tank to be recognised from the other two tanks. Another method of distinguishing the squadron HQ is to add numbers to the tanks, or to affix a pennant. There is no mandatory system for identifying individual tanks, but 1, 2 and 3 barrel stripes is practical and effective.

The Company Commander is a special conversion. Apart from the red turret and flag, we decided to add an open hatch and commander using the top half of one of the Imperial Guard models. The reverse of the flag has the company banding.

COMPANY HQ TANK



SQUADRON 1



SQUADRON 2



SQUADRON 3



CAMPAIGN BADGES

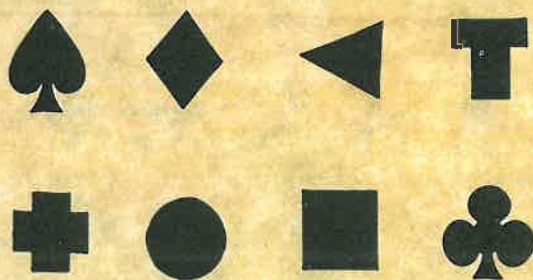

When the armies of the Imperium go to fight in a new campaign it is usual to adopt a symbol or insignia to be worn by all the troops and marked on all the vehicles. This campaign badge is worn on the uniform of every trooper, it is painted onto the armour of every Space Marine, and naturally it appears on tanks, artillery pieces, and other vehicles and equipment too. Campaign badges always take the form of simple geometric shapes or icons that can be easily painted or stencilled onto flat surfaces. In this way an entire force can be identified by one marking even though it includes Imperial Guard Regiments, Titan Legions, Space Marines from different Chapters and maybe even Squat allies. Some typical examples are shown here. The campaign badge is always chosen by the Imperial Commander in charge of all the forces, and it is used only for the duration of the campaign. Once the campaign is over the forces are dispersed and campaign markings painted over or replaced with new ones. Various examples of these campaign badges can be seen on the fully painted Baneblade models shown below.



BANEBLADES SHOWING A SELECTION OF MARKINGS



SHADOWSWORDS AND A STORMHAMMER COMPANY HQ TANK

SUPER HEAVY BATTLETANKS

Super heavy battletanks are organised into smaller companies than most tanks - a company consisting of 3 vehicles rather than 3 squadrons as in a normal company. In effect

each vehicle is equivalent to a squadron of smaller tanks. The examples shown above and on the previous page demonstrate how the colour schemes, camouflage patterns, company markings, and campaign badges may be brought together. In the case of these especially large tanks each tank in the company can carry a flag if desired. The examples show only one flag, but it is not uncommon for flamboyant commanders to use two or more, sometimes putting the company banded badge on one flag and the company emblem on the other. The HQ tank in each company can be distinguished in any way which makes the vehicle easily identifiable. A red turret or red guns, as in the Storm Hammer shown above, is one method. Another variation is to stripe the barrels with 1, 2 or 3 stripes to indicate each vehicle, or to add numbers to conspicuous areas of armour. In the case of these large vehicles it is easier to apply numbers as the areas are larger. You can, of course, combine any or all of these distinguishing features; there are no formal rules and the idea is to make the HQ tanks easy to recognise on the battlefield.

Notice how the different markings have been applied on the examples above. There is no formal position for any of the markings except the company banding, and even this is only a convenience that happens to suit these tanks very well. Different campaign markings have been used to demonstrate variety, but every force will have its own. A player with Space Marines and Imperial Guard troops will want to apply the same marking throughout, for example. The company badge is positioned wherever it readily fits - which in some cases is the side and in others the front track guards. On many tanks the turrets also have suitable areas for insignia or numbers.

ARTILLERY

The term artillery covers not only large self-propelled guns which fire explosive shells but also missile launchers and other weapons designed to launch barrages against massed enemy troops or buildings. The Imperium employs a great variety of these weapons including the Manticore missile launcher and Basilisk self-propelled gun, shown below. It is a common convention in the Imperial Guard to paint artillery in the colour known as Artillery Green although this colour is used for other vehicles too. This is not a strict rule, but it is felt that these weapons are generally placed behind the front lines in areas where they are unlikely to meet enemy face to face, and that the concept of camouflage is therefore less important than with other tanks. Using a standard colour therefore saves repainting the weapons when they are moved from warzone to warzone. In practice it is often necessary to adopt a different colour depending on the battlefield, in which case a suitable colour from the Codex Astartes is likely to be used, unless the commander feels a totally different scheme is called for.

Artillery company badges usually consist of a coloured square with a contrasting coloured circle painted on top - the colour indicating separate batteries.



Artillery Companies generally have three batteries each of three vehicles. As with tank squadrons it is necessary to mark the Battery HQ vehicle in some way to identify it easily, and this can be done either with a number, barrel stripes, by painting the weaponry in a distinctive colour, or adding a pennant. In the examples shown here the individual markings are on the other side of the vehicle although the company badge can be seen on the front plates of the Basilisks. On the whole a small pennant is the most effective method as this enables the piece to be identified most easily.



MANTICORE BATTERY



BASILISK BATTERY

SHADOW SWORD SUPER-HEAVY BATTLE TANK

The Shadow Sword super-heavy battle tank is a massive fighting machine which looks more like a mobile fortress than a tank. It carries a crew of 12 men to operate its fearsome battery of armaments, control its mighty engines and direct its ponderous movements. The Shadow Sword is enormous: as big as a building, and weighing upwards of a thousand tons.

It takes a long time to move Shadow Swords from one warzone to another and position them at the battlefield. They are hardly fast – it is rather difficult to move something that weighs a thousand tons and which is wider than most streets!

Once the Shadow Swords have reached the fighting zone they are used to provide anchor points in the battle lines – mobile fortresses which break the force of enemy attack. Shadow Swords also play an essential role in the attack, slowly rolling forward to present an irresistible force which few foes can withstand. They are used by the super-heavy tank formations of the Imperial Guard.

The Shadow Sword is so huge and heavy that its speed is inevitably very slow – 10cm. If your force contains Shadow Swords their speed will determine the rate of your advance. Because of this, it is vital to get them into a good position very early in the battle or you may find the action over before they have fired a shot!

Because of its extra-ordinary armour the Shadow Sword has an armour saving throw of 1 or more on a D6. This means that hits automatically bounce off harmlessly unless the weapon has a save modifier of at least -1. For example, if hit by a weapon with a -2 modifier the Shadow Sword would still save on a D6 roll of 3 or more (as 3 - 2 is still 1, which is sufficient to save). The Shadow Sword is

therefore immune to bolter fire from most vehicles, Ork Boyz stands, and other troops without a save modifier.

The super-heavy Shadow Sword is almost unstoppable in close combat, crushing infantry and lighter vehicles as it advances! To represent this the Shadow Sword can't be brought to a halt by lighter troops who engage it in close combat, it can only be pinned by Titans or by another super-heavy tank. If infantry or lighter tanks engage the Shadow Sword in close combat it can simply move past them in the next movement phase, scattering them out of the way as it does so.

The Shadow Sword is festooned with bolters to gun down infantry who come too near. Each individual bolter has only a limited arc of fire and a restricted range, but in combination the weapons are ideal for fighting off troops in close combat. The close assault factor of 6 reflects this, and also represents the super-heavy tank running down its opponents and crushing them beneath its broad tracks.

The Shadow Sword's main armament is a huge laser cannon called the Volcano Cannon, a weapon so powerful that others like it are used to defend planets against attack from space, firing through the atmosphere against drop ships and low-orbiting space ships. If the Volcano Cannon hits a Titan the player adds +3 to the damage roll to determine the effect.

The Shadow Sword also carries two lascannons in its auxiliary turrets, and many bolters which fire from restricted fire slits. The bolters are only intended as a last minute defence against infantry opponents at short range. Ideally the Shadow Sword will be protected by friendly infantry, as it is far too valuable to lose to a surprise attack by fast moving opponents.

| Troop Type | Move | Saving Throw | CAF | Weapons | Range | Attack Dice | Roll to Hit | Target's Save Mod. | Notes |
|-------------------------------|------|--------------|-----|----------------|-------|-------------|-------------|--------------------|---------------------------------------------------|
| Shadow Sword Super Heavy Tank | 10cm | 1+ | +6 | Volcano cannon | 100cm | 1 | 3+ | -4 | Volcano cannon adds +3 to damage rolls vs Titans. |
| | | | | Lascannon | 75cm | 2 | 5+ | -1 | |
| | | | | Bolters | 15cm | 6 | 6+ | 0 | |

BANEBLADE SUPER HEAVY TANK

The Baneblade is based on the same huge building-sized armoured body shell as the Shadow Sword with various modifications incorporating further hull armament and a separate turret. The Baneblade super-heavy tank does not carry any weapon as powerful as the Shadow Sword's Volcano Cannon, but it does carry more weapons and is better able to take on hordes of opponents thanks to its varied armament and many bolter positions.

The Baneblade is just as slow and ponderous as the Shadow Sword, and has the same thick armour and saving roll. The same special close combat rules apply as described for the Shadow Sword – it can only be pinned by Titans or other super-heavy tanks. The Baneblade is armed with a battlecannon which fires powerful explosive shells and a lascannon which shoots blasts of energy. It is also mounted with many bolt guns to protect the vehicle from infantry and other short range attack.

| Troop Type | Move | Saving Throw | CAF | Weapons | Range | Attack Dice | Roll to Hit | Target's Save Mod. | Notes |
|----------------------------|------|--------------|-----|--------------|-------|-------------|-------------|--------------------|-------|
| Baneblade Super Heavy Tank | 10cm | 1+ | +8 | Battlecannon | 75cm | 2 | 4+ | -2 | |
| | | | | Lascannon | 75cm | 2 | 5+ | -1 | |
| | | | | Bolters | 15cm | 10 | 6+ | 0 | |

STORM HAMMER SUPER HEAVY TANK

The Storm Hammer is one of the three types of Imperial super heavy tank and is just as well armoured as the Shadow Sword and the Baneblade. It is built for a close assault role and carries mostly short ranged weaponry. The Storm Hammer has two main turrets each carrying deadly cannons and four smaller turrets equipped with lighter bolters.

The Storm Hammer is designed to bring its armament to bear all round – as a close assault super heavy tank it would otherwise be vulnerable to attack from the sides and rear. As it is the Storm Hammer can wade in amongst enemy troops without suddenly finding itself unable to attack opponents who have closed in behind or round the sides. To further protect it against attack it has specially thickened side and rear armour.

To represent its wide arc of fire and many rotating turrets the Storm Hammer can shoot all round, not just to its front like most vehicles. Because of its extra thick side and rear armour its saving throw is *not* reduced for shots to the side and is only reduced by -1 for shots to the rear – most other vehicle saves are reduced by -1 and -2 for side and rear

armour of course. The same close combat rules apply as described for the Shadow Sword and Baneblade; it can only be pinned by other super heavy tanks.

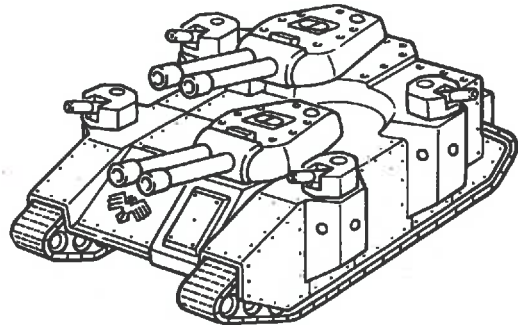

| Troop Type | Move | Saving Throw | CAF | Weapons | Range | Attack Dice | Roll to Hit | Target's Save Mod. | Notes |
|--------------|------|--------------|-----|-------------------|-------|-------------|-------------|--------------------|-------|
| Storm Hammer | 10cm | 1+ | +10 | Cannon Bolters | 50cm | 4 | 4+ | -2 | |
| | | | | | 15cm | 14 | 6+ | 0 | |

GORGON CLOSE ASSAULT VEHICLE

The Gorgon is a large, slab-sided vehicle with thick armour and monstrous tracks. It is used to carry infantry under heavy fire, such as in a siege or when attacking an enemy defence line. In many ways it is like a mechanical version of a heavily protected medieval siege tower full of combat troops and bristling with weapons!

In front the Gorgon has a very substantial bulldozer blade which it can use to push its way through obstructing terrain, and therefore ignores all penalties normally applied to vehicles for moving through some terrain. As a Gorgon moves through woods or over rocky ground it leaves a corridor behind it which is passable to other tanks. You can represent this by removing scenery as the Gorgon passes over it.

The bulldozer blade also forms a further layer of armour, so the Gorgon is allowed two saving throws for its armour if shot at from the front. Make your normal saving throw and if this fails roll again: the Gorgon is unharmed if either save is successful.

The Gorgon's high sides protect the infantry inside. The player can release the infantry in any turn, the Gorgon's

blade is raised and the infantry pour out of the vehicle. The Gorgon can carry up to 5 stands (25 men) and they disembark in the same way as troops leaving any other vehicle. The Gorgon is armed with short ranged mine launchers which lob large barrel-shaped charges a short distance ahead of its advance to clear out enemy troops.

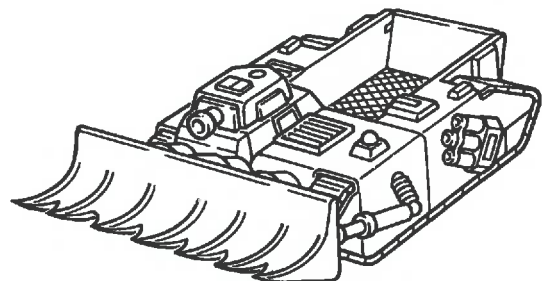

| Troop Type | Move | Saving Throw | CAF | Weapons | Range | Attack Dice | Roll to Hit | Target's Save Mod. | Notes |
|------------------------------------------|------|--------------|-----|-------------------------|-------|-------------|-------------|--------------------|------------------------------|
| Gorgon Super Heavy Assault Carrier | 10cm | 1+ | +4 | Bolters Mine Thrower | 15cm | 4 | 6+ | 0 | May carry 5 troop stands. |
| | | | | | 15cm | 1 | 4+ | -3 | |

GORGON ASSAULT COMPANY

An Imperial Guard Gorgon Assault Company consists of 1 company HQ unit plus 3 assault platoons, each with a Gorgon assault carrier. The Gorgon carries up to 5 stands.

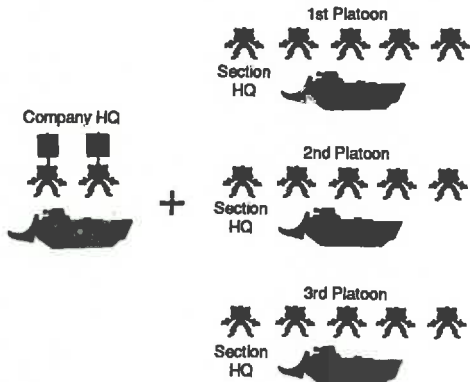

POINTS VALUE 500



GORGON ASSAULT COMPANY

BREAK POINT 11: The unit is broken once it has lost 11 models, either troop stands or Gorgons. Once the company is broken, each platoon must take a morale test.

MORALE VALUE 4: Imperial Guard have a morale value of 4, and must roll 4 or more on a D6 to pass their morale check.

For a platoon to receive orders its section HQ stand must be within 25cm of the company HQ at the start of the orders phase. The same also applies to any support units allocated to the company. If troops are unable to receive orders they cannot move but may fire in the advancing fire segment of the combat phase in the same way as other troops with no orders.

The company HQ unit is a command unit. It does not therefore need orders and there is no need for the unit to check morale.

VICTORY POINTS 5

Your opponent gains 5 VPs when this company is broken.

IMPERIAL GUARD SHADOW SWORD COMPANY

An Imperial Guard Shadow Sword Company consists of 3 Shadow Swords. No. 1 Shadow Sword is also the company HQ tank.

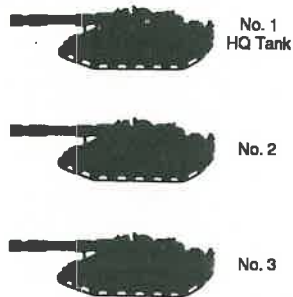

POINTS VALUE 500

IMPERIAL GUARD SHADOW SWORD COMPANY

BREAK POINT 2: The company is broken once it has lost 2 models. When the company is broken, the remaining Shadow Sword must take a morale check.

MORALE VALUE 4: Imperial Guard have a morale value of 4, and must roll 4 or more on a D6 to pass their morale check.

No. 1 Shadow Sword is the company HQ and so does not need orders and does not need to test morale. Shadow Swords no's 2 & 3 are each treated as if they were individual platoons and so must remain within 25cm of the no. 1 Shadow Sword to receive orders. If tanks are unable to receive orders they cannot move but may fire in the advancing fire segment of the combat phase in the same way as other troops with no orders.

The company HQ Shadow Sword is a command unit. It does not therefore need orders and there is no need for it to check morale. If additional support units are added to the company then their section or squadron HQs must remain within 25cm of the company HQ to receive orders.

VICTORY POINTS 5

Your opponent gains 5 VPs when this company is broken.

To make up your data cards, first photocopy the cards on this page. Fold each card along the dotted line and glue the two halves together on the inside. You can then use these cards as normal in your Space Marine games.

IMPERIAL GUARD STORM HAMMER COMPANY

An Imperial Guard Storm Hammer Company consists of 3 Storm Hammers. No. 1 Storm Hammer is also the company HQ tank.



No. 1
HQ Tank



No. 2



No. 3

POINTS VALUE 500

IMPERIAL GUARD STORM HAMMER COMPANY

BREAK POINT 2: The company is broken once it has lost 2 models. When the company is broken, the remaining Storm Hammer must take a morale check.

MORALE VALUE 4: Imperial Guard have a morale value of 4, and must roll 4 or more on a D6 to pass their morale check.

No. 1 Storm Hammer is the company HQ and so does not need orders and does not need to test morale. Storm Hammers no's 2 & 3 are each treated as if they were individual squadrons and so must remain within 25cm of the no. 1 Storm Hammer to receive orders. If tanks are unable to receive orders they cannot move but may fire in the advancing fire segment of the combat phase in the same way as other troops with no orders.

The company HQ Storm Hammer is a command unit. It does not therefore need orders and there is no need for it to check morale. If additional support units are added to the company then their section or squadron HQs must remain within 25cm of the company HQ to receive orders.

VICTORY POINTS 5

Your opponent gains 5 VPs when this company is broken.

IMPERIAL GUARD BANEBLADE COMPANY

An Imperial Guard Baneblade Company consists of 3 Baneblades. No. 1 Baneblade is also the company HQ tank.



No. 1
HQ Tank



No. 2



No. 3

POINTS VALUE 500

IMPERIAL GUARD BANEBLADE COMPANY

BREAK POINT 2: The company is broken once it has lost 2 models. When the company is broken the remaining Baneblade must take a morale check.

MORALE VALUE 4: Imperial Guard have a morale value of 4, and must roll 4 or more on a D6 to pass their morale check.

No. 1 Baneblade is the company HQ and so does not need orders nor to test morale. Baneblades no's. 2 & 3 are each treated as if they were individual platoons and so must be within 25cm of no. 1 Baneblade to receive orders. If tanks are unable to receive orders they cannot move but may fire in the advancing fire segment of the combat phase in the same way as other troops with no orders.

The company HQ Baneblade is a command unit. It does not therefore need orders and there is no need for it to check morale. If additional support units are added to the company then their section or squadron HQs must remain within 25cm of the company HQ to receive orders.

VICTORY POINTS 5

Your opponent gains 5 VPs when this company is broken.

GORGON ASSAULT SQUADRON

A Gorgon Assault Squadron consists of 1 Gorgon plus 1 assault platoon. An assault platoon is comprised of 5 Imperial Guard assault stands.



POINTS VALUE 150

The section HQ stand must remain within 25cm of its company HQ unit to receive orders. Place this card with its company HQ card to show its chain of command.

BREAK POINT 3: The squadron is broken once it has lost 3 models (stands or Gorgon). Once broken the squadron must take a morale check.

MORALE VALUE 4: Imperial Guard must roll 4 or more on a D6 to pass their morale check.

VICTORY POINTS 2

Your opponent gains 2 VPs when the squadron is broken.

SHADOW SWORD

This consists of one Shadow Sword



POINTS VALUE 200

The Shadow Sword must remain within 25cm of its company HQ unit to receive orders. Place this card with its company HQ card to show its chain of command.

BREAK POINT: As a single vehicle the Shadow Sword has no break point. Victory points are only awarded once the vehicle is destroyed.

MORALE VALUE 4: Imperial Guard must roll 4 or more on a D6 to pass their morale check.

VICTORY POINTS 2

Your opponent gains 2 VPs when the vehicle is destroyed.

BANEBLADE

This consists of one Baneblade.



POINTS VALUE 200

The Baneblade must remain within 25cm of its company HQ unit to receive orders. Place this card with its company HQ card to show its chain of command.

BREAK POINT: As a single vehicle the Baneblade has no break point. Victory points are only awarded once the vehicle is destroyed.

MORALE VALUE 4: Imperial Guard must roll 4 or more on a D6 to pass their morale check.

VICTORY POINTS 2

Your opponent gains 2 VPs when the vehicle is destroyed.

STORM HAMMER

This consists of one Storm Hammer.



POINTS VALUE 200

The Storm Hammer must remain within 25cm of its company HQ unit to receive orders. Place this card with its company HQ card to show its chain of command.

BREAK POINT: As a single vehicle the Storm Hammer has no break point. Victory points are only awarded once the vehicle is destroyed.

MORALE VALUE 4: Imperial Guard must roll 4 or more on a D6 to pass their morale check.

VICTORY POINTS 2

Your opponent gains 2 VPs when the vehicle is destroyed.

LAND SPEEDER

THE COMPLETE LAND SPEEDER CONSISTS OF:

- 1 x CHASSIS
 - 1 x ENGINE MOUNT
 - 1 x BANNER POLE
 - 1 x DRIVER
 - 1 x HEAVY BOLTER MOUNTING
 - 1 x SWIVEL MOUNTED WEAPON
 - 2 x SEATS
 - 2 x ENGINES
 - 1 x HEAVY BOLTER
 - 1 x RIDER
- PLEASE STATE WHICH ITEMS YOU REQUIRE WHEN ORDERING**



THIS IS AN EXAMPLE OF A COMPLETED LAND SPEEDER WITH SPACE MARINE RIDERS

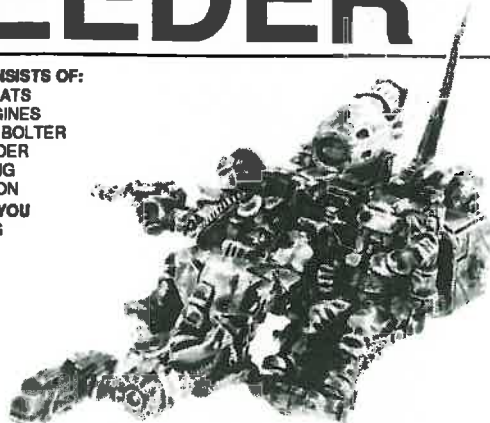

THIS IS AN EXAMPLE OF A COMPLETED LAND SPEEDER WITH IMPERIAL GUARD RIDERS



**CHASSIS
RTB3/F**



**MARINE RIDER
RTB3/A**



**MARINE DRIVER
RTB3/B**



**SEAT
RTB3/H**



**ENGINE MOUNT
RTB3/C**



**IMPERIAL GUARD RIDER
072156/1**



**IMPERIAL GUARD DRIVER
072156/2**



**ENGINE
RTB3/G**



**HEAVY BOLTER MOUNTING
072155/5**



**HEAVY BOLTER
072155/4**



**SWIVEL MOUNTED
MULTI MELTA
RTB3/E**



**SWIVEL MOUNTED
HEAVY PLASMA GUN
072155/3**



**BANNER POLE
RTB3/D**

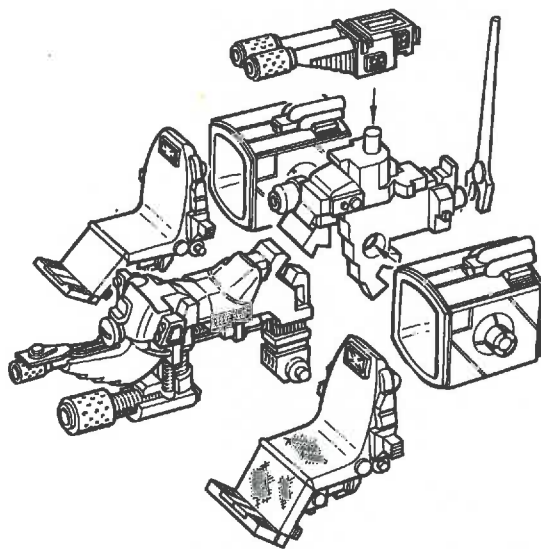

© Copyright Games Workshop Ltd. All rights reserved.



Designed by Michael Perry

SPACE MARINES



CHAPLAIN WITH
POWER SWORD
070133/60

CHAPLAIN WITH CHOZIUS
AND BOLTER
070133/58

CHAPLAIN WITH
CROZIUS
070133/61

CHAPLAIN WITH
CHAINSWORD
070133/57



CHAPLAIN WITH
PLASMA PISTOL
070133/62

CHAPLAIN WITH
COMBI-WEAPON
070133/58

TECH MARINE
WITH TOOL BOX
070133/74

TECH MARINE WITH
POWERDRIVER
070133/73



TECH MARINE WITH
BOLT PISTOL
070133/70

TECH MARINE WITH
BLOW TORCH
070133/69

TECH MARINE
WITH WRENCH
070133/72

TECH MARINE WITH
ADJUSTABLE WRENCH
070133/71



MEDIC WITH
BOLT PISTOL
070133/65

MEDIC WITH
HAND FLAMER
070133/67

MEDIC WITH
BOLTER 1
070133/84

MEDIC WITH
PLASMA PISTOL
070133/66

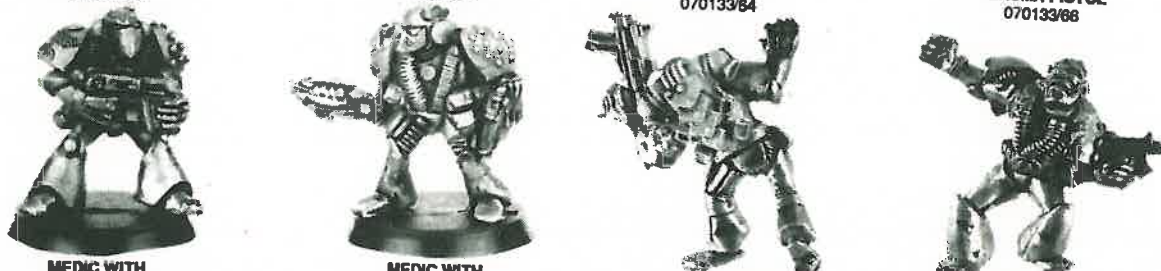

MEDIC WITH
BOLTER 2
070133/63

MEDIC WITH
CARNIFEX
070133/68

WOUNDED 1
070106/12A

WOUNDED 2
070106/12B

ALL OF THE ABOVE MODELS ARE SUPPLIED WITH A SPACE MARINE
BACK PACK AND BANNER SPRUE AS STANDARD

Designed by the Citadel Design Team

© Copyright Games Workshop Ltd. All rights reserved.



SPACE MARINES



**POWER GLOVE
AND BOLTER**
070145/3



PLASMA GUN 1
070145/18

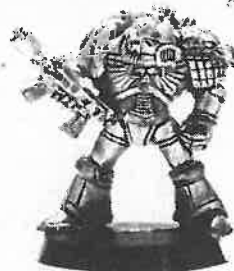

BOLTER 1
070145/14



**HOODED TABARD
AND POWER SWORD**
070145/17



**TERMINATOR HONOURS
AND BOLTER 1**
070145/6



**TERMINATOR HONOURS
AND POWER GLOVE**
070145/4



**TERMINATOR HONOURS
AND BOLTER 2**
070145/5



CHAIN SWORD 1
070119/22



LIBRARIAN AND TOME
070145/8



LIBRARIAN AND SCROLL
070145/7



**LIBRARIAN AND 2 HANDED
FORCE SWORD**
070145/9



**BIONIC EYE
AND BOLT PISTOL**
070119/25



CAPTAIN
070145/10



LIEUTENANT COMMANDER
070145/11



LIEUTENANT
070145/12



FLAMER
070119/24



**POWER SWORD
AND BOLT PISTOL**
070119/23



POWER SWORD
070119/26

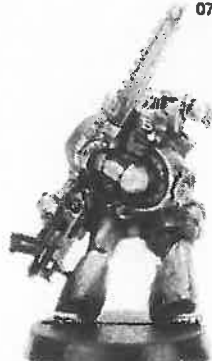

**CHAIN SWORD
AND BOLTER**
070119/29

Designed by the Citadel Design Team with Aly Morrison

ALL OF THE ABOVE MODELS ARE SUPPLIED WITH A SPACE MARINE
BACK PACK AND BANNER SPRUE AS STANDARD

Attention: supplied unpainted. WARNING: This product contains lead which may be harmful if chewed or swallowed. Citadel Miniatures are not recommended for children under 14 years of age.
 © Copyright Games Workshop Ltd. All rights reserved.



**CITADEL
MINIATURES**

IMPERIAL TANKS & WAR MACHINES

THE COMPLETE BANEBLADE CONSISTS OF:
 1 x BANE BLADE CHASSIS
 1 x BANEBLADE TURRET
 1 x SPONSON TURRETS 1



**BANEBLADE
 SUPER HEAVY BATTLETANK**

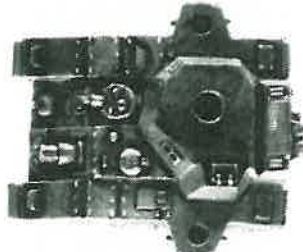

**BANEBLADE CHASSIS
 076054/1**



**BANEBLADE TURRET
 076054/3**



**SPONSON
 TURRETS 1
 076054/2**

THE COMPLETE SHADOWSWORD CONSISTS OF:
 1 x SHADOWSWORD CHASSIS
 1 x VOLCANO CANNON
 1 x SPONSON TURRETS 2



**SHADOWSWORD
 SUPER HEAVY TANK DESTROYER**

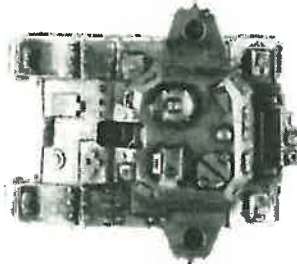

**SHADOWSWORD CHASSIS
 076054/4**



**VOLCANO CANNON
 076054/5**



**SPONSON TURRETS 2
 076054/6**

THE COMPLETE LEMAN RUSS CONSISTS OF:
 1 x LEMAN RUSS CHASSIS
 1 x LEMAN RUSS TURRET



**LEMAN RUSS
 BATTLE TANK**

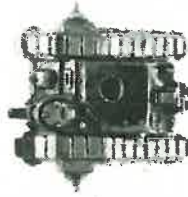

**LEMAN RUSS CHASSIS
 076041/7**



**LEMAN RUSS TURRET
 076015/6**

THE COMPLETE PREDATOR CONSISTS OF:
 1 x PREDATOR CHASSIS
 1 x PREDATOR TURRET
 1 x LAS-CANNON SPONSONS
 1 x PREDATOR LEFT SIDE
 1 x PREDATOR RIGHT SIDE



PREDATOR

**PREDATOR TURRET
 076041/4**



**PREDATOR
 LEFT SIDE
 076041/2**



**PREDATOR CHASSIS
 076041/1**



**LAS-CANNON
 SPONSON'S
 076041/5**



**PREDATOR
 RIGHT SIDE
 076041/3**

THE COMPLETE WHIRLWIND CONSISTS OF:
 1 x WHIRLWIND CHASSIS
 1 x WHIRLWIND MULTI LAUNCHER
 1 x WHIRLWIND SIDES



WHIRLWIND



**WHIRLWIND CHASSIS
 076066/9**



**WHIRLWIND
 MULTI LAUNCHER
 076066/10**



**WHIRLWIND
 SIDES
 076066/8**



© Copyright Games Workshop Ltd. All rights reserved.



CITADEL
 MINIATURES

Designed by the Citadel Design Team with Colin Dixon

IMPERIAL TANKS & WAR MACHINES

**THE COMPLETE STORM HAMMER
CONSISTS OF:**
1 x STORM HAMMER CHASSIS
2 x STORM HAMMER TURRETS
2 x SPONSON TURRETS 2



STORM HAMMER



STORM HAMMER CHASSIS
076054/7



STORM HAMMER TURRET
076054/8



SPONSON TURRETS 2
076054/6



MANTICORE TYPE 2

**THE COMPLETE MANTICORE TYPE 2
CONSISTS OF:**
1 x MANTICORE / BASILISK CHASSIS
1 x MANTICORE MULTI-LAUNCHER TYPE 2



**MANTICORE MULTI-LAUNCHER
TYPE 2**
076066/7

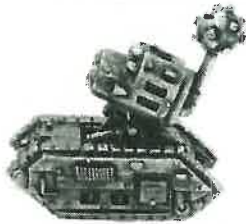

MANTICORE TYPE 1

THE COMPLETE MANTICORE CONSISTS OF:
1 x MANTICORE / BASILISK CHASSIS
1 x MANTICORE MULTI-LAUNCHER TYPE 1



**MANTICORE MULTI-LAUNCHER
TYPE 1**
076066/6



**MANTICORE / BASILISK
CHASSIS**
076066/3



BASILISK TYPE 1

THE COMPLETE BASILISK CONSISTS OF:
1 x MANTICORE / BASILISK CHASSIS
1 x BASILISK CANNON TYPE 1



**BASILISK CANNON
TYPE 1**
076066/4



BASILISK TYPE 2

**THE COMPLETE BASILISK TYPE 2
CONSISTS OF:**
1 x MANTICORE / BASILISK CHASSIS
1 x BASILISK CANNON TYPE 2



BASILISK CANNON TYPE 2
076066/5



VINDICATOR Mark 2
076041/10



GORGON Mark 1
076041/11



GORGON Mark 2
076041/12

Manufactures supplied unpainted. WARNING: This product contains lead which may be harmful if chewed or swallowed. Citadel Miniatures are not recommended for children under 14 years of age. © Copyright Games Workshop Ltd. All rights reserved. © Citadel Games Workshop Ltd. All rights reserved.



Designed by the Citadel Design Team

| DESCRIPTION | UK PRICE | DESCRIPTION | UK PRICE |
|--------------------------------------|-----------------|---------------------------------|----------------|
| SPACE MARINE | £24.99 GAME | SHADOWSWORD | £3.99 COMPLETE |
| EPIC STOMPERS | £9.99 BOX SET | SHADOWSWORD CHASSIS | £3.00 EACH |
| TERROR IN THE DARK | Phone for price | VOLCANO CANNON | £0.75 EACH |
| DRAGON MASTERS | Phone for price | SPONSON TURRET 2 | £0.30 FOR 2 |
| D-ROK "GET OUT OF MY WAY" 12" SINGLE | Phone for price | LEMAM RUSS BATTLE TANK | £3.99 FOR 3 |
| D-ROK "GET OUT OF MY WAY" CD SINGLE | Phone for price | LEMAM RUSS CHASSIS | £1.00 EACH |
| D-ROK "OBLIVION" ALBUM | Phone for price | LEMAM RUSS TURRET | £0.50 EACH |
| D-ROK "OBLIVION" TAPE | Phone for price | PREDATOR | £3.99 FOR 3 |
| D-ROK "OBLIVION" CD | Phone for price | PREDATOR CHASSIS | £0.50 EACH |
| | | PREDATOR TURRET | £0.30 EACH |
| | | LAS-CANNON SPONSONS | £0.30 FOR 2 |
| | | PREDATOR SIDES | £0.60 FOR 2 |
| WARHAMMER 40,000 LAND SPEEDER | £6.99 COMPLETE | WHIRLWIND | £3.99 FOR 3 |
| CHASSIS | £1.50 EACH | WHIRLWIND CHASSIS | £0.50 EACH |
| SEAT | £0.75 EACH | WHIRLWIND MULTI-LAUNCHER | £0.50 EACH |
| ENGINE MOUNT | £0.75 EACH | WHIRLWIND SIDES | £0.60 FOR 2 |
| ENGINE | £1.00 EACH | STORM HAMMER | £3.99 COMPLETE |
| HEAVY BOLTER MOUNTING | £0.30 EACH | STORM HAMMER CHASSIS | £3.00 EACH |
| HEAVY BOLTER | £0.65 EACH | STORM HAMMER TURRET | £0.50 EACH |
| SWIVEL MOUNTED MULTI MELTA | £0.65 EACH | SPONSON TURRETS 2 | £0.30 EACH |
| SWIVEL MOUNTED PLASMA GUN | £0.65 EACH | MANTICORE | £3.99 FOR 2 |
| BANNER POLE | £0.30 EACH | MANTICORE / BASILISK CHASSIS | £1.00 EACH |
| RIDERS | £1.35 EACH | MANTICORE MULTI-LAUNCHER TYPE 1 | £1.00 EACH |
| | | MANTICORE MULTI-LAUNCHER TYPE 2 | £1.00 EACH |
| EPIC IMPERIAL TANKS & WAR MACHINES | | BASILISK | £3.99 FOR 2 |
| BANEBLADE | £3.99 COMPLETE | BASILISK CANNON TYPE 1 | £1.00 EACH |
| BANEBLADE CHASSIS | £3.00 EACH | BASILISK CANNON TYPE 2 | £1.00 EACH |
| BANEBLADE TURRET | £0.75 EACH | VINDICATOR MARK 2 | £3.99 FOR 3 |
| SPONSON TURRET 1 | £0.30 FOR 2 | GORGON MARK 1 | £3.99 FOR 2 |
| | | GORGON MARK 2 | £3.99 FOR 2 |

ALL MODELS SUBJECT TO AVAILABILITY

| ORDER FORM | | |
|--------------------------------|-------------------------------|----------------------------------------|
| CODE / DESCRIPTION | QTY | TOTAL PRICE |
| | | |
| | | |
| | | |
| | | |
| | | |
| | | |
| | | |
| | | |
| TOTAL: | POSTAGE & PACKING: | GRAND TOTAL (TOTAL + P&P) = |
| NAME AND ADDRESS: | | |
| | | |

HOW TO ORDER CITADEL MINIATURES

We strongly recommend that you phone in your orders. You'll be talking directly to the Mail Order specialist who'll actually be packing and dispatching your order. He'll be able to tell you exactly what is and isn't available, and suggest alternatives in the case of any problems. He will also be able to tell you about any new models that have become available since last issue, and any special offers we may be running on old, discontinued or overstocked items.

If it's simply not possible for you to order by phone then it doesn't matter too much. All you have to do is tell us the name (if available) and code. Be as explicit as you can when writing out your descriptions of the models you want. This is particularly important if you want to order a particular combination of parts for a multi-part kit. We recommend using block capitals to avoid confusion!

ALTERNATIVES

You should always let us have a list of alternatives when ordering by post. Even if you make an order by phone. It is wise to give a few alternatives. The only reason we won't be able to supply you with a model is if it has been discontinued and the mould is no longer available on the factory floor. Normally speaking we manage to supply 95% of all orders. Our staff will be happy to suggest viable alternatives for any models which are out-of-stock or no longer produced.

DESPATCH AND DELIVERY

We always try to despatch your orders within 2 days of receipt, quite often we get them out the same day. Remember that parcels take longer than letters, but you should, in general, get your order back within 10 days. We do occasionally get behind, but this usually only happens when we hold a large sale with lots of irresistible offers, and at Christmas.

FOREIGN ORDERS

We are very happy indeed to supply foreign orders through our UK Mail Order Department.

POSTAGE & PACKING

Total up your order and add the following postage & packaging costs.

UK & BFPO: add £2.50

Overseas (including Eire): add 40%. If you pay by credit card, P&P will be charged at cost.

METHODS OF PAYMENT

You can pay by cheque or postal order. Alternatively, we take Access and Visa cards - write with your order, and include the card number, the cardholder's name and signature, the card expiry date, and your name and address. Better still, phone our Mail Order Helpline to place an immediate order - make sure you have your Access or Visa card with you when you phone.

UK MAIL ORDER

Our UK Mail Order Helpline are open for your orders from 9.00am to 6.30pm on weekdays. The numbers to ring are (0773) 760462 or (0773) 713213

If you're writing in with your order, send it to:

GAMES WORKSHOP MAIL ORDER SERVICE,
CHEWTON STREET, HILLTOP,
EASTWOOD,
NOTTINGHAM NG16 3HY

Or you can fax the order through on
(0773) 530155



US MAIL ORDER

For US telephone orders (Visa and Master Card only) ring (301) 644 5699, Monday through Friday between 9.00am and 5.00pm EST. Or you can post orders to:

GAMES WORKSHOP MAIL ORDER SERVICE,
3431 G BENSON AVENUE,
BALTIMORE, MARYLAND 21227-1072

Please add \$3.00 postage and handling. Maryland residents add 5% sales tax, residents in Virginia add 4.5% sales tax, residents in California add 8.25% sales tax and residents in Pennsylvania add 6% sales tax. Write for free catalogue.

Cash, COD, and Canadian Postal Money orders are not accepted. Minimum order is \$20.00 and postage will be free if your order is over \$120.00.

You can also fax Access and Visa miniature orders direct to the US on (301) 242-1839. Please remember to include the card number, the cardholder's name and signature, the card expiry date and your name and address. Handling will be charged at 40% or cost, whichever is cheaper.

CANADIAN MAIL ORDER

For Canadian telephone credit card orders (Visa and Mastercard only), ring (416) 595 1159, Monday to Saturday between 11.00am and 8.00 pm EST.

Postage and handling will be charged at cost. Please note that we are taking telephone credit card orders only. For postal orders, please contact our US Mail Order Service.

SPACE MARINE™

EPIC STOMPERS

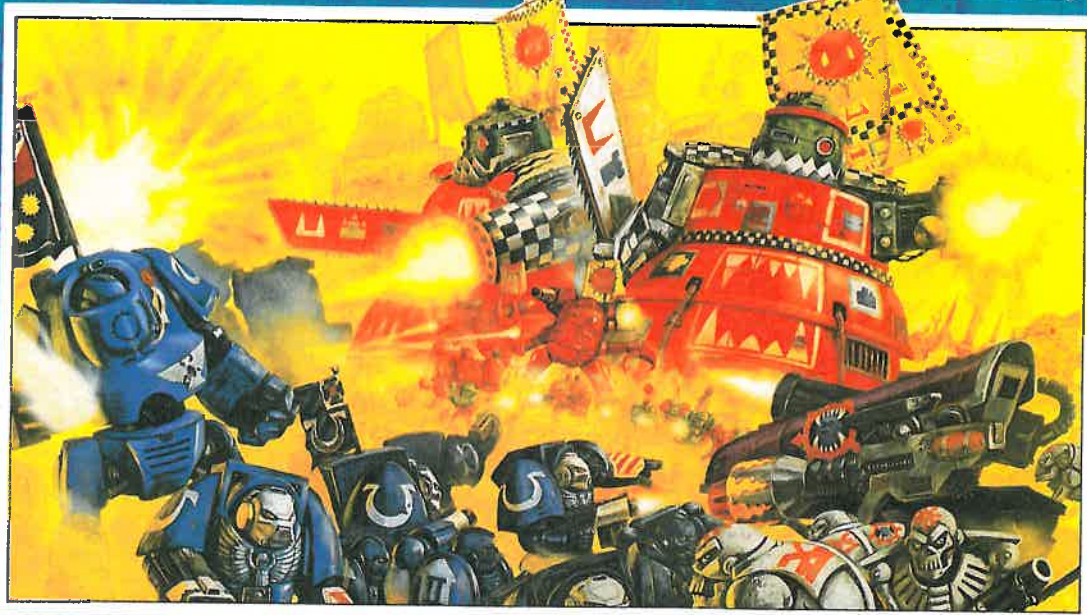

SPACE
MARINE™

ELDAR, ORK, MARINE AND CHAOS DREADNOUGHTS FOR USE WITH SPACE MARINE

WARHAMMER
40,000™
GWS

EPIC STOMPERS SPRUE 101557

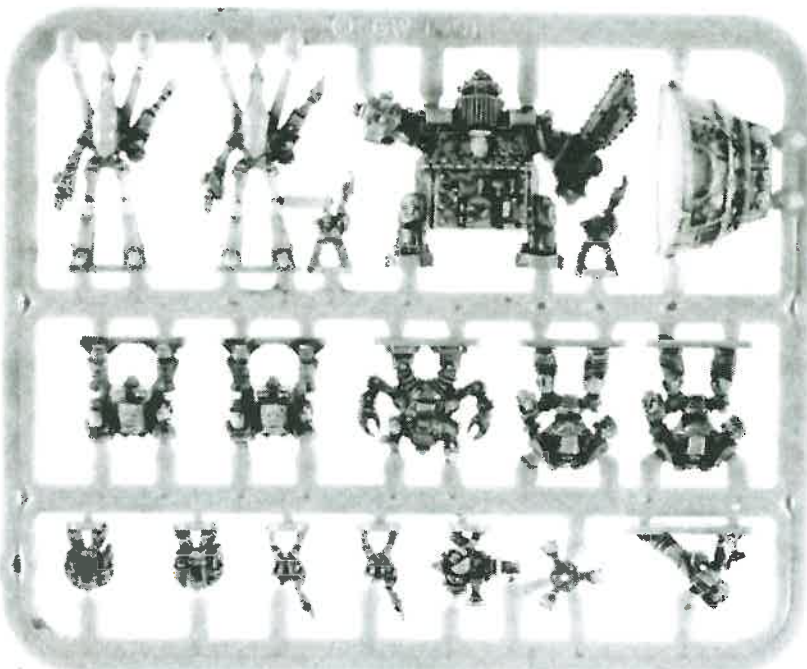

The Epic Stompers box set contains 6 sprues of highly detailed plastic miniatures for the Space Marine game.

Each box contains:

- 6 Ork Stompers
- 12 Eldar Dreadnoughts
- 6 Ork Dreadnoughts
- 24 Chaos Androids
- 12 Marine Dreadnoughts
- 6 Ork Shokk Attack Guns
- 12 Chaos Dreadnoughts
- 12 Marines in Terminator Armour
- 6 Mole Mortars

GAMES
WORKSHOP



BRETONNIAN KNIGHTS IN BATTLE AGAINST AN UNDEAD HORDE