

Druchii.net Quarterly

Part 2

The Call of Khaine _____ 52

Imdat Tauble's army is far from complete. Join him on his quest of Asurbashing as he attempts to have an army ready for the Storm of Chaos

Druchii Weapons: From Relation to Reality _____ 59

A new series, focusing on how different weapons are based on historical fact, and how they worked and were used. This quarter, Iyagd sheds some light on the Repeater Crossbow.

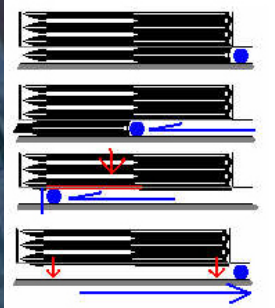

The Aspects of Khaine _____ 64

Another new series, where each quarter the Cult of Pleasure will bring you information on some of the Aspects of Khaine. This quarter you will see no less than 4 of these masterpieces

The Druchii Language Guide _____ 69

Sorely missed in the last Quarterly, the Druchii Language Guide has everything you need to know about the Dark Elf Language from how to count to complex sigil creation. Includes a 5-page English-to-Drukh-Eltharin dictionary, so naming your army general is now a breeze!



Famous Black Arks _____ 86



Yet another new series from the Cult of Pleasure, this time focusing on the famous Black Arks of Naggaroth. This quarter, the tale of two such Arks are told...

Imdat Tauble _____ 92

Follow Imdat Tauble on an autobiographical frenzy as he tells the story of one of his more zany characters.



RPG Hero Building _____ 98

For those who are wanting to join the RPG, or who are perhaps more experienced who want some tips, this article concentrates upon the character building aspect of the Druchii RPG.

Just to recap...

This issue of the quarterly is so large that we have had to split it into 3 distinct sections, each with a separate contents page. This is the second of these sections.

f
o
n
t
e
n
t
s

Introduction:

With the Storm of Chaos campaign approaching, I decided that it was finally time for me to get my army going so that I may have the chance to participate. I am planning to build what measly army I have into a fully-fledged 2000 point army, something I have been trying to do for years. However, there are problems, the most pertinent being that of school and exams (being in my final year, time is extremely hard to come by!) closely followed by the problem of me being a below-average painter. Finishing my army requires me to pick up a paintbrush, something that I have dreaded since starting the army (I have wielded the evil instrument before, and there were few survivors). The first step is, of course, the one thing I have done over the last few years - getting the fluff together.

Part 1: Gathering Fluff

When I first picked up my Dark Elf book all those years ago, the first thing I noticed was the Executioners and the Assassins. The ideas behind these two units inspired me to create an assassination army - one that could cut down enemy characters with ease (and did, for a price). The first thing I did was to create the fluff for one of the assassins, Delthazor. It was posted on a very old version of the site, made absolutely no sense at all (when you have people dying and then coming back after tricking Khaine into letting him go, it seems a bit of, usually) and contained too many grammatical mistakes to count. Eventually, I plan to remake it, in conjunction with a more believable storyline.

The main idea behind him is that he was in Har Garneth with a unit of Executioners. At one point he is given a magic dagger which controls his mind, making him kill certain people. Eventually he breaks the spell, but not before he's wanted dead by Malekith himself. So he rebels, and joins an assassination army, lead by the next character I will describe, Ryani Vermkin.

Now Ryani was the son of a Black Ark Captain, but during an Empire raid, he was separated from his parents and was brought up by a warrior family. True to his blood, he decides to become a Corsair, and rises up the ranks. Eventually he finds his parents, who are killed shortly later by a competitor for their rank. He has a few problems with the new captain (for obvious reasons), gets really pissed off and decides to go and create an assassination army, bringing corsairs from the ship who were loyal to his parents as a starting force.

My next two characters, Imtura Valtriel and Khaitani Indemor, start off as witch elves. I won't reveal anything more (other than that Imtura becomes a sorceress) for now, as I am currently writing their story in the History of the Druchii forum. One thing I will say, however, is that they are a part of the force from the start.

The
K
h
a
i
n
e
f
l
u
f

My last character, Imdat Tauble, is a complete wildcard. The first four parts of his story are in this issue - look out for more in quarterly's to come.

So now I have my characters, they're all together, ready to kick some character butt, but what about the army as a whole?

I've decided that my army could only have certain units in it as others would be against the fluff. The first, and most obvious, is Corsairs - they come straight from Ryani's mob. My second unit is my Dark Riders, an essential part of any assassination army, as they come to harass and distract the enemy while I go for their characters. The next is, of course, the Executioners. The ones that are not actual executioners are trained by Delthazor in the art of assassination, giving them their amazing skill with the blade. The next are the shades, again, to harass and annoy the enemy, as well as going for the lone mages. For characters, my options are rather obvious, with Ryani being either a Noble or a Highborn and the rest of them simply following their fluff.

Part 2: The forces gather... sometime... maybe... after Christmas...



Before I made my theme, I actually bought my first box of warriors and made some of them Repeater Crossbow armed. These are the most amusing models I currently have, as apart from being the only unit I have completely painted (and no, the painting isn't pretty), half of them have their hands and rxbs upside down! Now I use them for bits, whenever I find the need for it.

About this time, I found Druchii.net, so you may appreciate how long ago that was (if you can figure it out, please tell me - I seriously don't know myself). But then I figured out my theme and began to collect proper models, however slowly.

The first thing that you will notice about my models (if you ignore the fact that half of them are broken due to bad gluing etc.) is that they are made from warrior box parts, but aren't actually warriors! Both of my executioners and my corsairs are made in this way, and I'll quickly run through the process:

1. Make the legs, torso and head as per a normal warrior.
2. Glue on the arms with the appropriate weapons. For Corsairs, I just used my imagination - you can pretty much do anything from nail boards to weird spiny things (see my painted Corsair). With the Executioners, I used a spear arm and cut the spear back so it looked for like a sword. Then I added in a second arm and used enough green stuff on the shoulder so that the arm would join the end of the new sword. Remember to let Green Stuff dry at least 10-20 minutes before using - for most of them I didn't, and it really wasn't very good. Also, make sure you glue stuff on as well as using Green Stuff - I have countless swords that have fallen off due to using Green Stuff alone and no glue.
3. For the corsairs, make the cloak. This involves getting some Green Stuff, and simply making a thin square out of it. Then you need to place it onto the corsair's neck, bending and squashing the top of the square to fit it around. This usually creates a very realistic look. My corsairs do not actually have Sea Dragon cloaks as such as they have no bumps - if you want to make these, you need to get little spheres of Green Stuff and press them onto the cloak.



The second thing that you will probably notice about my models is that a hell lot of them aren't actually glued to the bases - some have actually been cut from theirs. This is part of an insane plan of mine to have a more terrain-based base, using movement trays only. I pretty much pin the feet to the terrain movement tray (pictured right), but leave the bottom of the pins unglued so that they can be taken on and off.

Other substitute models I have used include mounted Ringwraiths for Imdat Tauble and my Dark Riders (they just looked too cool to pass up). Note especially Imdat himself (the only painted Ringwraith) - I am especially proud of the conversion I worked with the dead(ish) Snotling riding shotgun.

Of my fully painted and complete models, there are currently 6, 1 of which was scratch-built (although hardly - it looked really bad so I whacked a cloak over the whole thing). Realise that I painted all of these on the same night, just before a skirmish campaign I recently played in (see further on). By the time I got to the shade, I really didn't care. I believe I have two options here - to redo it, or to show a similar style to the rest of my models. Right now, I'm leaning towards the second.



Models to come include whole units of scratch-built units (lots of cloaks as you might imagine) and some spearmen, as well as some of the real executioner models which I just can't resist. However, I'll follow that up in the army list section.

Part 3: A massacre, a massacre, a massacre, and wait - a minor loss!!!

Well it's about time that I tell you about my battles so far, which has been few and far between. All I can remember of my first battle is Dwarves, hill, organ gun killing full units at time and me losing rather miserably. I can remember getting into combat at one stage and having my very small exe unit getting kicked by the stubborn dwarves. And obviously, I lost. However, that was a while ago - since I have gone and learnt some 'tactics'. For example, do not try to kill an organ gun with just 1 unit of Dark Riders - their charge range is the same as the organ guns, so by the time they arrive, they will be slightly dead. Also, multiple charges against Dwarves usually help. So does heavy armour for my Executioners.

Anyway, I learned from that loss and got back into the swing. I believe I may have lost a couple of other games, but I do not wish to depress the reader too much. Next two games were against a friend of mine who had never played fantasy before, but was familiar enough with 40k. He also played Dark Elves (proxing, as he was just trying it out). The first game involved a map with a small pass in the middle and cliffs to the side (represented by a doorframe). I think he was supposed to get past it and failed (the



doorframe obviously wasn't big enough). However, I have more documentation of the second game, which was later dubbed "The sword in the Snotling". I lost this game by so little, but a loss is a loss, and I learnt one thing - if your objective is to grab an item and it could be held by any character and only 1 has a 1+ save, go for him first. Trying to put everything into him in the last turn doesn't always work as well as it does when killing Dark Riders.

More recently, I have played half a game with both the same friend (also known as Twiddle - i believe he actually has an account here on Druchii.net) and Sneaky. This time, Sneaky and I played Dark Elves (naturally) and Twiddle played Tomb Kings. We didn't finish the game, but I was (naturally) in a good position, and thus would be able to wipe them from the map very shortly afterwards (except for the fact that my plan required them to have the IQ of a rock). I believe I played better tactically in this game than others, although in a 3-way battle alliances are always fickle and there are always unexpected surprises.

In September, however, I played my first Warhammer-related tabletop game with fully-painted miniatures. It was a Warhammer Skirmish campaign, and it involved me, Sneaky (as GM), Twiddle (with Lahmian VC's, an army he's likely to continue) and another friend, who took up the call of Chaos Khorne. With 3 evil armies at the ready, we just knew that blood would be spilt. Soon enough, it was, with Sneaky immediately bringing in some of his own guys (Dark Riders) to try and kill us all. With alliances changing every turn, it was definitely interesting, and a campaign which we wish to conclude at some point (we only had 1 day to play, not nearly enough for the weirdness that was unfolding).

Since then, the battlefield has remained quiet.

Part 4: Plans, and an Army List.

So what am I to do now? I have 6 months to create this army, and I believe I can do it. If I assembled everything that I can make right now, I would have a total of 1325 pts of the 2000 I am aiming for, which means that buying the rest may not be so much of a problem. However, taking the time to make it will. I plan to use quite a bit of the time in the Summer Holidays (Late December-End of January here in Oz) to make models, although that probably won't be enough. Pretty much, I'll just have to wing it and see how I go.

My army list, annotated with Tactics, fluff and some Painting & Modelling ideas, is as follows:

The Characters

Noble, General, HA, Sea Dragon Cloak, Crimson Death – 115 pts

This is Ryani, and he belongs in a unit of executioners. The idea here is to have him able to boost combat resolution and leadership at the same time.

Sorceress, level 2, Lore of Dark Arts, Dispel Scroll, Darkstar Cloak, Dark Steed – 187 pts



Meet Imdat. His job is to go around and cause havoc everywhere. The model I'm using is my one painted Ringwraith model.

Sorceress, level 2, Shadow Lore, Seal of Ghroind, Web of Shadows – 180 pts
 This is Imtura, and for now, I'll use the sorceress on foot model as I don't have the cash or energy to convert something special (this may change though). She uses shadow magic to launch herself (hence the Web of Shadows) and the assassin into the right area (i.e. kill lone mages, War Machines etc.). She will hopefully get a half-decent second spell too, and use that to cause more havoc. She goes in a unit, most probably one of the executioner ones as then she can hang back a bit and see the assassin easily.

Assassin, 2nd Weapon, Rune of Khaine, Manbane - 179 pts
 This is Delthazor. He goes in a unit (often in a Corsair/Spearman unit near Shadow Sorceress or in Shades) and either causes havoc there or goes war machine hunting/flying. I will be using my Assassin model.

Core Units

Warrior Blocks

The two blocks following are my two big blocks. I will be using them as an anvil, with enemies charging these before being flanked by others.
 16 warriors, full command – 137 pts
 These guys are a part of Ryani's retinue. They will be made from warrior parts - pretty simple really.



16 warriors, full command – 137 pts

These warriors will be scratch built, and will be from Imdat's followers. They will simply be guys with big swords, the first rank of which will be kneeling to show how the second line is able to fight over them.

Corsair blocks

These units will be small flanking units. Needless to say, one will probably have an assassin in it.

10 corsairs, champion and musician – 115 pts

10 corsairs, champion and musician – 115 pts

Both of these units will be made from warrior parts and are from Ryani. However, I may decide to make some subtle differences between them, although what these would be I don't know.

The Dark Riders

These three units will do what Dark Riders usually do - piss other people off. Why else would I take them?

5 Dark Riders, repeating crossbows, musician - 127 pts

The first unit will be made with my remaining ring wraiths and are a part of Imdat's bunch.

5 Dark Riders, repeating crossbows, musician - 127 pts

The second unit will be proper Dark Rider models, courtesy of Ryani

5 Dark Riders, repeating crossbows, musician - 127 pts

This third unit will be scratch built and are the most ambitious modelling project I wish to undertake. Right now I am thinking that they are Imdat's people who were originally on foot before finding random mounts (which may just be other horses), but I have a

couple of other ideas. We'll see what happens.

The Special Units

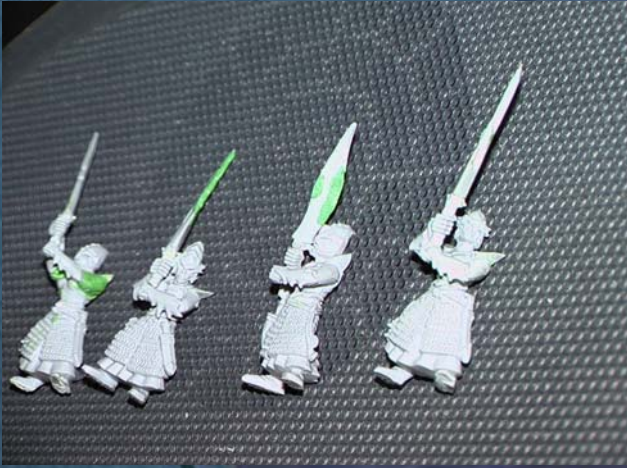

Executioners

These guys are around simply to flank and cause trouble to the opposition. Oh, and to kill them too.

10 Executioners, champion, musician - 128 pts
This first unit is from Ryani, and will be built from warrior models. See the ones I already made for reference.

10 Executioners, champion, musician - 128 pts
This unit will be actual executioner models (shock! horror!). I just couldn't resist them.

They will be a retinue that Delthazor brought along

10 Executioners, champion, musician - 128 pts

Yet another scratch-built unit from Imdat. These guys will (if I can manage it) have nice long scythes to cut people open with. Failing that, I'll go for the big swords

Shades

These guys hunt war machines and wizards. A redundancy for all the other war machine/wizard hunters I have.

5 shades - 70 pts

These guys will be normal shade models, pretty simple stuff really.

Total: 2000

Casting Pool: 7

Dispel Pool: 5

Models in Army: 106

So that's my army list, all finished and accounted for. So what do I still need to buy? Following is a list:

5 Dark Steeds

1 box of 10 Executioners

1 blister of Shades

Lots and lots of Green Stuff

I believe I can acquire all of this over in one or two purchases. How and when I get the time to make and paint them is a slightly different story.

So to sum up, I've got a lot of models to make up and paint and not much time (considering work etc.) to do it. Plus, I have to pick up a paintbrush! Will I be ready to go and destroy the Asur when the time comes? Only time will tell.

Imdat.



From the Druchii Weapons Department

Part 1: Repeating crossbow.

Excuse me, are those your bolts in my chest?

Repeating Crossbow. Uraithen, Deathrain. A Weapon used almost exclusively by Druchii warriors, combining a high rate of fire with the natural skill of the Elves. The background and game mechanics are well known to all of you, and thus, this article will neither describe it's role on the battlefield nor its place in Druchii weaponry, but instead will concentrate on it's possible design and construction, while also commenting on how it could be used and maintained in reality.

The Crossbow.

All of you, as fantasy wargaming and RPG enthusiasts, know what a crossbow is, how it works and how it is constructed. To sum this up, the crossbow is a ranged weapon, shooting bolts thanks to the power of its short, massive bow and thick bowstring. The triggering mechanism is very simple, but the main problem for eons has been the same – reloading. For the centuries in which it was used, many methods for cocking the mighty string were invented – hooks, winders, cranks and various lever mechanisms. Yet in the 14th century it was almost impossible to reload it with bare hands. In effect the missiles were loosed with growing force, able to penetrate the thickest armour. Constructed with modern materials, nowadays it is used for either sport, hunting or military applications.

The first evidence of crossbows comes from China, while in Europe it was used from the times of the Romans. It was a very dangerous weapon, which although slower than the bow, packed a lot more punch. Even the village idiot was able to shoot the mightiest Knights from their saddles. The crossbows were made redundant by black powder weapons, which changed battlefields forever.

The Repeating Crossbow

But, what is the Repeating Crossbow then, you may ask.

Firstly, note the word "repeating". Not "self-repeating", but "repeating". Without going into the subject in great detail, the phrase implies that the Crossbow needs some outside force to cock and reload it, in same way as the 19th-20th century rifles, the so-called lever-action rifles.

It is believed that the Repeating Crossbow was invented in China around 100-150 AD, but there are written sources mentioning its existence as far back as 200BC! The first pictorial evidence of it comes from the times of Ming Dynasty, and photographic evidence comes from the late 19th century when they were used during the Boxer Rebellion. As the name suggests, the Repeating Crossbow is capable of loosing an enormous number of bolts in very short time period. The main problem is, as with the crossbow, reloading and cocking – a lot

of force is needed to cock the bowstring in a short time if it is to be operated by one shooter without the need of outside mechanisms. In addition to this, it needed to be relatively light, had to allow targeting and must be easy to operate with one hand. If you are thinking about volleys of bolts loosed with one pull of the trigger, you're wrong. That is impossible, unless multiple strings or bows are used, in which case the weight and size of such a crossbow, or rather bolt thrower, would be too great for use by one warrior. Not mentioning that the cocking and repeating mechanism of such a weapon would be very complicated and therefore prone to breakage.

Possible Construction

In this section, I am assuming that all crossbows mentioned have bows made from high quality steel or hard wood of even composite. The crossbow's stock should be made from relatively light materials with finely crafted metal parts in the vital sections. I'm bearing in mind technology level in given era, which would be approximately equivalent to that of the Renaissance. But note also that Druchii had millennia to improve the construction of the Uraithen.

The first design is based on the Chinese Repeating Crossbow, the Chu Ko Nu [Figure 1]. The original construction came without a triggering mechanism. The shooter handled the crossbow with one hand while other hand reloaded, achieving a speed of one shot loosed per second. The bolts had no fletches and the magazine capacity was around 10 bolts. The bolts had sufficient power at a range of up to 60-70 m. The magazine section is separate and movable [Figure 1a]. It has long notch in the bottom section. The missile lies in the groove, and the springs powering it stop at the end of shaft. Then the joint lever moves the magazine forward and slightly down, as shown by the blue lines in Figure 1. The lever may not be joined but straight, acting with same effect [Figure 1a]. The string stays in the notch and anchors into the recess at the back part of the section [Figure 1b]. Then, due to a large amount of leverage, the shooting section is pulled into loosing position. The string comes up from the recess and drives the next missile. After locking the magazine section in the rear position, the bowstring is not released but lies in latch, the so called nut [Figure 1c]. The simplest way of reloading bolts is where bolts are lying on top of one another, and once the string moves out from under the next bolt, it simply falls down [figure 1d].

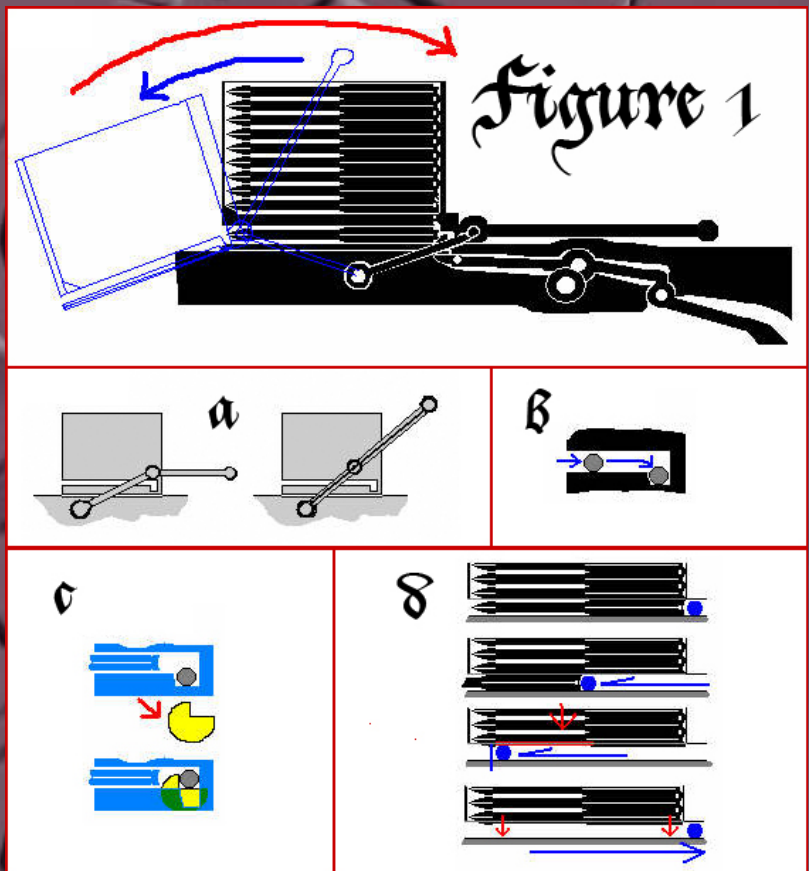

The second method of construction is a combination of the above construction with a powerful underlying spring, which powers the backing device [Figure 2] and gives a

necessary mechanical advantage. This allows for easy, quick bowstring cocking. The spring is made from a very flexible metal and is very tightly curled. It stores enough power to enforce the cocking mechanism. After firing a suitable amount of bolts inside the spring must be tightened up with some kind of crank. The magazine section is movable, able to move forward to the nose and back to the latch on well greased slides. After the bolt is fired, the operator moves the lever forward, cranking the section along. The spring doesn't resist yet. When the section reaches its forward position, it locks. Then the moving lever further unleashes the power of the spring, forcing the lever back. The string is inserted into the recess and the whole section slides back with the string into the rear position.

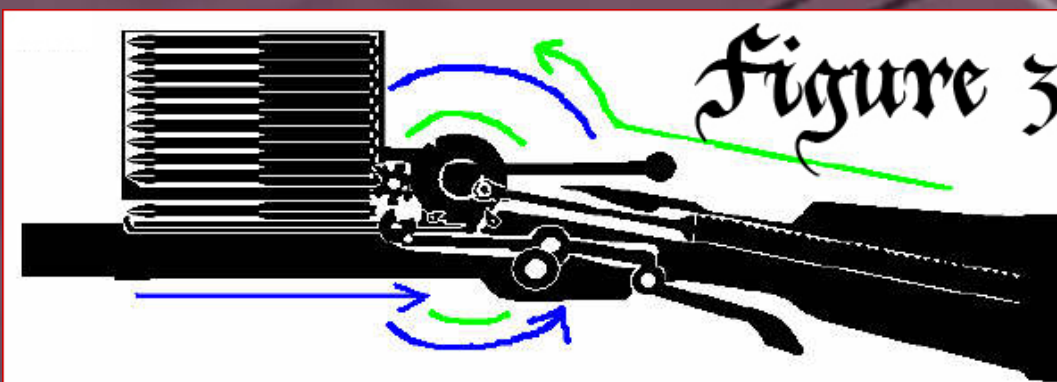
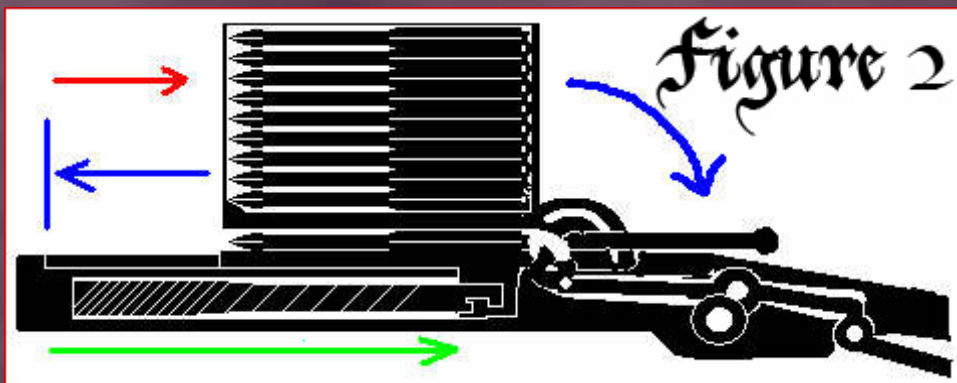

The third design is based on springs too, enforcing the turning of the cocking mechanism [Figure 3]. The powering device is based on several gins, gears and wheels on which one or two strong cords are curled. They are placed in two small grooves on both sides of the main track [Figure 3a]. After firing, the cords, which end with hooks, catch the string. Then the crank is turned, pulling the cords, which are thus coiled onto two gins, thus drawing the bowstring back. Then the string is placed on the latch

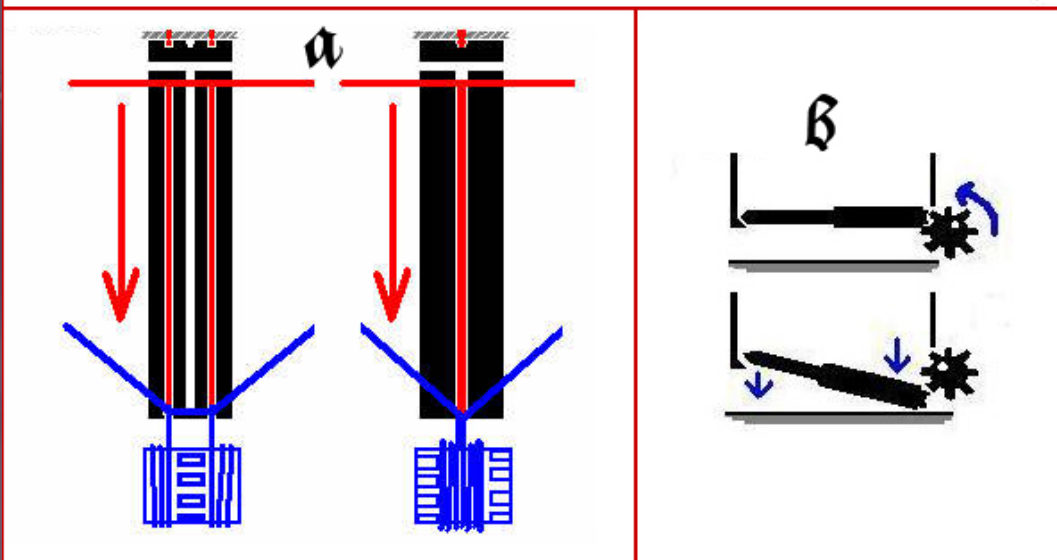

and the crossbow is ready to shoot. Of course there may be only one cord used, however, using two creates a smoother cocking motion. Turning the crank also turns a small gear-wheel which allows next bolt to fall down into main groove [Figure 3b]. When the string is locked, further movement of the crank releases the gins free, so that the cords do not resist.

The fourth and final design is variation of the third, and is the most probable to be the Druchii design in my opinion. Construction is similar to version no 3, but the enforcing spring is placed inside the gin [Figure 4]. This makes the cocking device is more solid and compact, meaning that cocking is simpler and turning the lever is enforced with the spring, resulting in lower power loss than in the other designs presented. It is also strongly based on the existing model range (especially Dark Riders).

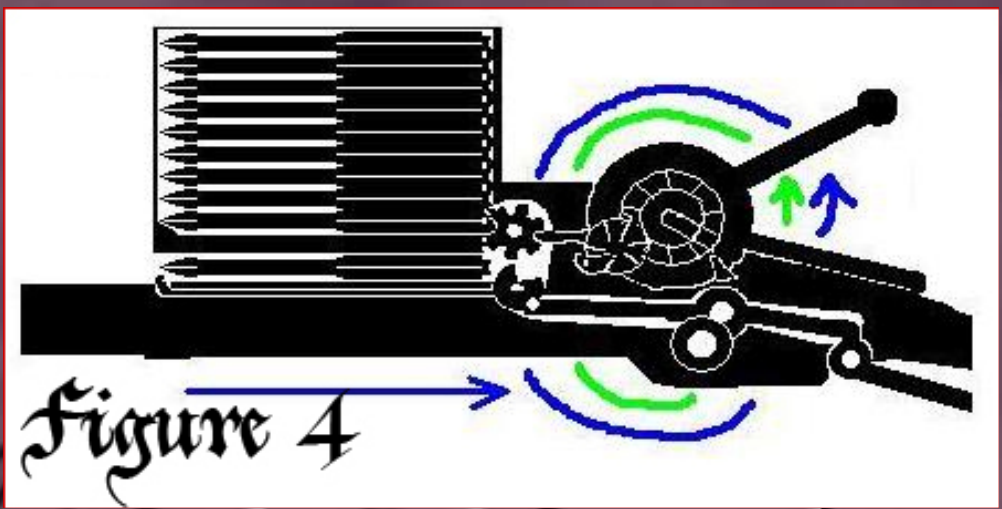

Materials

All of the designs above are possibly Druchii in my opinion. Note that all of them demand a skillful manufacturer and high quality materials. Enforcing strings must be made from flexible, high quality steel. They must be strongly tightened up during the manufacturing process to store a suitable amount of mechanical power. The repeating device, including the system of gins, levers and gear-wheels closely resembles the mechanism of a clock. Being both very subtle and sophisticated, the weapon must be carefully crafted and precisely assembled. All the moving parts should be made from hard steel or another similar material. The bows are probably made from steel, horn, hard wood or some kind of composite material. The handle may be made from hard wood, horn or even bones. The suitably tough bowstring along with gins and gear-wheels is the part that will wear the fastest in the crossbow, as although it is very durable, high stresses means that it loses many of its characteristics over time, so it must be changed very often, otherwise dull shots will occur frequently. Also, the ripping of bowstrings is an obvious problem.

Maintenance

Sophisticated construction of the repeating crossbow determines the manner in which it should be maintained. To assure the highest combat performance, it must be exceptionally well maintained. All of the cocking device's moving parts must be perfectly and regularly cleaned and greased. The shooter must carry his crossbow in special holster to secure the complicated and fragile mechanism from dirt and mechanical damage. As gear-wheels, gins and bowstring are easy to tear away, he must carry also spare parts and at least few spare bowstrings. In his tool set, he must have some kind of crane, assuring enough mechanical advantage for tightening the spring when needed.

Overall Stats

The repeating crossbow is able to fire around 1 bolt per 1-2 seconds at top speed. The amount of bolts fired also depends on the bolt's magazines. The accuracy of the repeating crossbow when shooting at a high rate is very poor. Relating it to modern times, it is similar to firing a machine gun with a high amount of recoil. For better accuracy, the shooter may shoot while targeting with crossbow butt on shoulder in a classical rifleman

position, but for higher rate he must shoot with the handle held underarm. The second way is more plausible, as such crossbows are designed to fire clouds of bolts rather than being used for sharp shooting. The effect of such salvo is devastating, despite small power of missiles. The maximal range is around 100-120 m, but effectiveness of bolts on this range is problematical, as it may not shot through the cap on a head. Maximum effective range of the first design discussed is around 20-30 m. Other, spring powered designs may have a slightly longer effective range, but no more than 50 m. Knowing that, one possible way to use the crossbow on the battlefield is firing in more or less regular salvos, loosing clouds of bolts at high rates without targeting. Realize that 100 crossbowmen can fire around 3000 bolts in a minute, taking into account the time needed for changing magazines! Of course, the shooter must carry the necessary number of magazines, and thus achieving such results as those stated above is extremely difficult due to sheer weight of them.

Figure 5

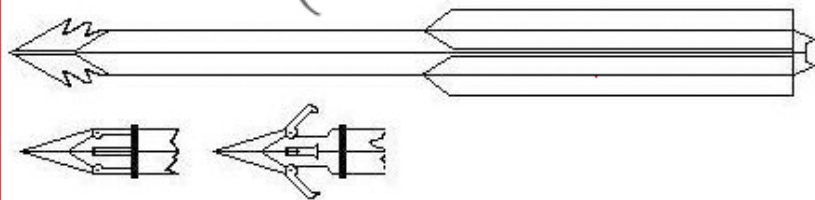

Bolts

The bolts used should be relatively short and lighter than normal crossbow bolts, with long fletches laid along the bolt [Figure 5]. Sometimes there is no accuracy demand, so the bolts come with no fletches at all (same as the original Chinese bolts). There may be various bolt designs, including barbed and poisoned ones.

So, that's my view of the repeater crossbow. I'm not an engineer or constructor, so it may be incorrect, but chances are that I am on the right track. Opinions, comments and feedback would be much appreciated.

Next time we take a closer look at Druchii hand weapons...

- Iyagd

You know you have played too much warhammer if...

A joke by Kaazmodan

11. You wonder if there's a way to shrink historic buildings to use as terrain.
12. You model furniture for your model houses.
13. You tear up your forbidden rod card, burn it and scatter the ashes.
14. You start to ask for Bugman's at the local pub.
15. You consider a Chaos Dwarf hat fashion.
16. You spend sleepless night's worrying about the helm of many eyes/Double Handed weapon issue.
17. You tell your fiancee that her engagement ring is the ring of corin.
18. You wonder if you can deadlock your neighbour's lawnmower at five o'clock in the morning.
19. You buy a pet rat and name it Queek.
20. You consider buying a chariot for your next car.

Look out for more of these throughout the issue!

The
K
e
p
e
c
t
e
f
e
f

K
h
a
i
n
e

Introduction

Khaela Mensha Khaine is the dark power to whom almost the entire Druchii race gives worship. The Bloody-Handed God, unlike the brutal warrior deities venerated by humans and other lesser creatures, is a being of infinite complexity whose sophistication is as absolute as His cruelty and malice. As there are many hundreds of methods of killing known to the Druchii, so Khaine has many hundreds of names and faces. Each form taken by the god represents a different aspect of murder, from the stealthy and relentless Stalker of the Void to the sudden onslaught of the Winged Predator. These aspects are often viewed as a pantheon of distinct yet complementary powers by Khaine's followers. The true adepts of Khaine, the assassins, each take on a specific aspect of the god, dedicating themselves utterly to the mastery of its particular tools and methods of killing. This quarter, the Cult of Pleasure takes a look at four of Khaine's aspects.

The Deathbringer



The Deathbringer, the aspect of Khaine as the Merciless Slayer, is rightly one of the most terrifying faces of the great deity. Khaine takes on this horrifying aspect in times of war and pillage when the dread hosts of the Druchii fall upon the unwary peoples of the lands across the ocean. The raiders delight their watching god as they callously butcher their helpless victims, killing children before their parents' horrified eyes, hacking down fleeing villagers and massacring entire communities merely for the few moments of pleasure that such bloodshed brings. But Druchii too may feel the touch of the Deathbringer, for He appears on Death Night when slaves and Druchii alike are slaughtered without any thought of mercy or restraint, their blood filling the streets of the cities of Naggaroth.

The aspect of the Deathbringer is most properly worshipped during the lavish six-day festival known as the Harvest of Souls, when the Druchii noble houses give many of their slaves in sacrifice to the temples, to die bloodily upon the dark god's altars. These gifts may be rewarded on Death Night, should the sacrifice be great enough to merit such an exemption, but those families who do not placate the hags and their dark master can expect to know only agony and death when the witch elves next rampage through the city streets.

To write the rune of Khaine in his aspect as the Merciless Slayer is close to blasphemy, as it is one of His most holy aspects, its sign guarded

closely by the hag queens and assassins of the temples. It inspires fear in all those who look upon it for even those not of Druchii blood recognize it for what it signifies: horror, pain and indiscriminate slaughter.

The assassin who wishes to follow the path of the Deathbringer must endure many tests. First, he must overcome his own fears - fear of Khaine, fear that the aspect will turn against him. Once his fear is mastered, he must show what it means to be a merciless slayer. Some try to prove their worth by finding their original families and taking their sharp blades to their throats. Others cross the oceans with the corsair raiding parties and journey long in the lands of the humans, slaying all living things they come across, whether they be men, women, children or animals. The Deathbringer is one of the most dangerous aspects to follow, and many who try die in the attempt. Those that survive, however, become some of the most potent assassins to ever live.

"During the time known as the Age of Hateful Peace, as we rebuilt our forces and planned the next great offensive against the depraved elves of Ulthuan, a young maibd from the Temple of Clar Karond took it upon herself to create for the Witch King's armies a great weapon - one that would inspire terror in the hearts of even the bravest of the corrupt warriors of Ulthuan. Taking a piece of ancient yew wood blackened by the sacrificial pyres of her temple, she began to carve into its smooth, dark surface a face that had haunted her dreams for many years. I know not how long she laboured upon her great work, but upon the final day of the festival of the Harvest of Souls, she immersed her creation in one of the last remaining True Cauldrons. Caressing the mask's harsh features, the warm blood imparted some of its magical energy to the old, dark wood, imbuing it with the distilled terror and despair of countless slaughtered innocents. After a time, the young witch lifted the mask from the cauldron and smiled at the face of her god, the Deathbringer. Over the centuries, the mask has been sheathed in gold to preserve its power, but its sacred features have never been altered and it remains one of the most holy relics of the cult of Khaine to this day."

- excerpted from Volume IX of the Books Of Blood, by Lord Furion of Clar Karond

The Iron Panther

Jonas rounded another corner as fast as he could. His boots slipped for an instant on the rain-slicked cobbles and the sword flew from his sweaty hand, clattering away into the darkness of the alley. He had to get to the guardhouse as soon as possible, to warn them of the dangers that waited in the night, of the monster that stalked him relentlessly through the midnight streets of Altdorf - the same terror that had struck down all the rest of his company in no more than a heartbeat.

The nightmare thing had been waiting for them in the shadows. The first of the fine soldiers of the Emperor, Malric, had made no sound as the deadly blade ran through his armour and into his heart. Dernem and Gunther had died before Malric's corpse had touched the cobbles. Jonas did not want to remember the rest that had chosen to stand their ground and fight. Nor did he wish to recall the fates of those who had fled with him and had been cut down one by one at the leisure of the dark warrior.

He was almost there, the guardhouse only a hundred paces ahead. He did not dare turn to look behind him.

This was one of the more prosperous sections of the city, the houses in this street belonging to rich merchants and petty nobles who liked to display their wealth openly. The overabundance of gargoyles was familiar to Jonas and, as he ran, he did not notice the presence of one dark, crouching shape that was not made of stone. Only once Jonas had passed by beneath its perch did the creature move, spreading its black cloak like wings.

Jonas made no sound as the deadly blade ran through his armour and into his heart. There was only a rustle of silk as the assassin vanished back into the shadows of the city streets.



The aspect of the Iron Panther, the Stalker of the Void, is one of the more common depictions of Khaine to be found among the holy places of Naggaroth. It is in this aspect that Khaine protects His loyal children, lurking in the shadows of the Void to devour those who dare come close enough to feel His power. Dreadful is the strength of His mighty claws as they tear His victim's soul asunder before tossing the ravaged remnant into the nether reaches of the Emphyrean, where its scream fades into the silence of eternity. It is in this aspect that Khaine has the most control over the winds of magic and therefore

it is one prayed to fervently by both sorceress and hag alike as their sects vie for power in the Land of Chill.

Veneration of the Stalker of the Void is most properly observed in silence, in an effort to surround oneself with the Void in which He resides, to surround oneself with His divine protection. This aspect is never witnessed at any of the many festivals and holy days observed in Naggaroth, for all objects bearing the likeness of the Iron Panther are put away until such time as any festivities have ended. They are shrouded in many layers of dark velvet to separate them from the world of the living, to make them as much a part of the Void as possible and thereby ensure the protection of the great deity when it is needed.

Any adept of Khaine who wishes to follow this one of the thousand aspects of his glorious God must learn above all else the art of patience. The total control of one's own emotions and the knowledge of when and where to most efficiently employ the arts of death are a form of worship in themselves. In this aspect, Khaine values the patient, cunning and relentless stalker above the rash and thoughtless slayer. In following this aspect, the assassin keeps to the shadows, silently watching his prey from the darkness, tormenting them with terror of the unknown and slowly driving them towards oblivion. It is said that assassins devoted to the aspect of the Iron Panther will go so far as to mimic the actual stance of their God and become as statues, waiting in silence and shadow until such a time as their chosen victim comes near enough to be pounced upon by a living incarnation of Death itself.

The Serpent Lord

In His aspect as the Serpent Lord of Divine Agony, Khaine is known by the name Chroesh, the sound of a venomous snake striking. Today, few among the Druchii offer devotion to the god in this form. Not only do the Serpent Lord's rituals of worship necessitate a great deal of pain for the worshipper, but also the name of this particular aspect-cult has been blackened by association with the Cult of Pleasure and with the forbidden veneration of Slaanesh.

The aspect-cult of Chroesh is even older than the Dark Elf race, birthed as it was in the shadowy lands of Nagarythe in the time

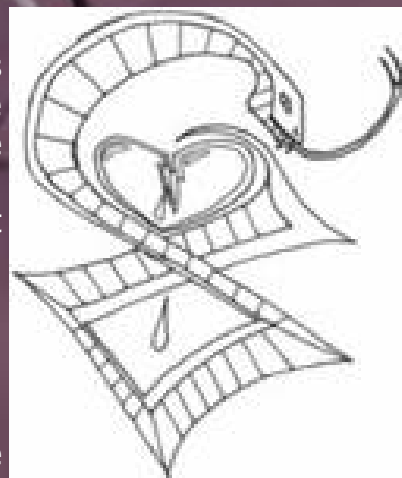

of Aenarion. Morathi, the Phoenix King's beautiful but sinister wife, patronised several obscure and esoteric cults in the days of peace following the first scouring of Chaos from the land of Ulthuan. The most well-known of these was the Cult of Pleasure, ostensibly a group of the most skilled poets, sculptors and other artists from Nagarythe and the other kingdoms of Ulthuan, but in reality a cabal devoted to the worship of Slaanesh. Many of the other cabals, covens and cults the sorceress favoured were dedicated to Khaine. The Bloody-Handed God was held in high regard all across Ulthuan in those days and Aenarion, the first to unite all the elven kingdoms, was seen as the god's mortal incarnation. It was, then, only fitting that his wife should worship Khaine in all his many aspects.

Among these many aspect-cults was the little-known cult of the Serpent Lord. It numbered perhaps only a dozen members when Morathi first learned of it. Her firstborn son, Malekith, had not yet seen his first summer and, devoted as she was to him, the daily monotony of caring for the infant had begun to bore the sorceress.

The cult's emphasis on the pleasurable and purifying qualities of physical pain awoke long-buried memories in Morathi's twisted mind. Before Aenarion had rescued her, she had been a slave in the torture pits of Slaanesh. Although she had never admitted it to her husband, she had not been a mere victim of her captors but an enthusiastic collaborator. The concept of deriving pleasure from inflicting and receiving pain had always appealed to the darker side of her soul and now the cult of the Serpent Lord gave her the opportunity to indulge her desires with a mask of respectability.

With Morathi's patronage, the aspect-cult flourished, but its teachings were subtly altered. Its prayers became more ambiguous. The idea of pain purifying the body and soul was largely ignored in favour of pursuing more and more extreme physical sensations. In time, it became almost indistinguishable from certain sections of the Cult of Pleasure. Wherever the Serpent Lord cult was active, young elves would disappear. Occasionally, their flayed and mutilated corpses would be found, their faces frozen in expressions of unspeakable agony.

By the time such atrocities had become evident, the events that would lead to the Sundering had begun. The Serpent cult fled to the icy land of Naggaroth, where most of its adherents settled in the city of Clar Karond. Morathi eventually lost interest in the cult, her attentions diverted by her struggle with Hellebron for the leadership of the main cult of Khaine and the loyalty of the witch elves. Its long association with the Cult of Pleasure led to the Serpent cult's members being persecuted by the other aspect-cults so that it never regained its former status.

Few assassins devote themselves to Khaine in his aspect as the Serpent Lord and those who do are often despised and distrusted by their fellow adepts. The worship of Chroesh involves many rituals of self-scarification and the rank and devotion of each adherent is measured by the runes carved into his flesh. As the serpent is a poisonous beast, so the adepts of the Serpent Lord are experts in the distillation and application of many potent venoms. Decades or even centuries of imbibing small quantities of these deadly substances as part of the Serpent Lord's rituals of worship means that his adepts are almost totally immune to their effects themselves.

The Devourer

"To defeat your foe, you must not merely slay him. You must erase him totally from history, obliterating all trace and memory of his existence. His name must be forgotten and all those who carry his blood in their veins must likewise be culled. Your foe must not only cease to exist. He must never have existed."

- The Black Tome, chapter LVII, verse 16

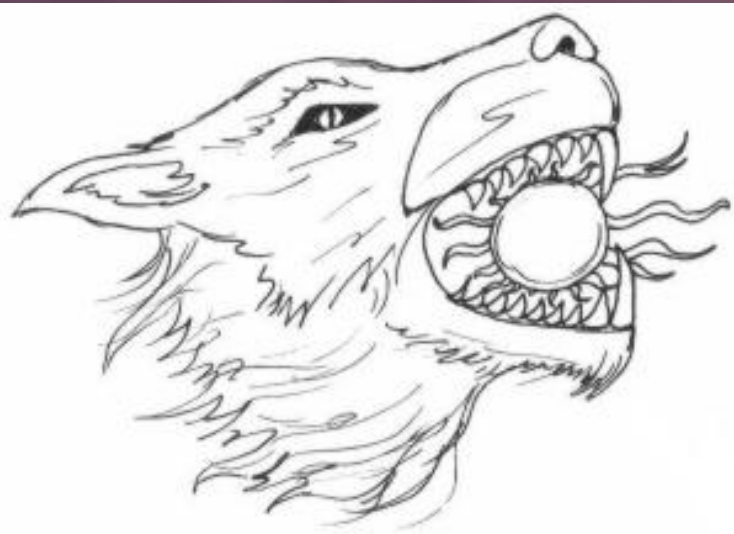

Such are the guiding principles of those assassins who follow Khaine in His aspect as the Wolf Who Devours The Sun, also known as the Dragon Of The Void or the Bringer Of Night. The Devourer sect is one of the most secretive of Khaine's aspect-cults. Assassins who devote themselves to this aspect take a vow of silence so that none can ever learn of their deeds or the names of those they have slain. They themselves have no names, for they are no longer individuals, but merely faceless agents of Khaine's implacable vengeance. If they are spoken of at all, even by the

witch elves and their hags, they are referred to in hushed whispers only as the Devourers.

Yet there are some scholars, among both the Druchii and the other races, who say that references to the Devourer can be found amid the very oldest of myths and legends. Glyph-tablets of immeasurable antiquity from Lustria speak of great beasts that consumed the very stars themselves to sate their terrible hunger. A single crumbling scroll kept in a locked room at the heart of the White Tower of Hoeth carries the last known transcript of a tale in which star-eating giants known as the Yngir fought against the gods in aeons past before they were lulled to sleep by the songs of Lileath.

On the very rare occasions when a large number of the Witch King's subjects are conspiring against him, it is usually an adept of the Devourer that he sends to wreak his vengeance. All those who are even suspected of complicity simply disappear, along with their families and all those who were close to them. No bodies are ever found. Those who displease the Witch King simply cease to be - their names are erased from all records and no loyal Druchii will ever speak of them again. There are no traitors among the Druchii. Traitors do not exist. They have never existed.

No-one knows what ultimately happens to those the adepts of the Devourer steal away but, wherever there is uncertainty, rumour creeps in. Those Druchii brave or foolish enough to speak of such things say that the Devourer's victims suffer the most hellish of torments before death as the assassins devour their victims alive, making literal their aspect's sinister name. Some say that the adepts of the Devourer have even mastered a secret ritual which allows them to consume the souls of their victims, thus denying them any continued existence even in the Emyrean. That these horrors are visited upon not only the assassin's specified target, but upon all those who knew him as well, only adds to the dread in which these agents of the Witch King's vengeance are held.

Drukh-Eltharin – The Dark Elf Language

The Dark Elf language is in essence very similar to the Eltharin tongue of their High Elf foes. It is based upon the dialect spoken in Nagarythe at the time of Aenarion, but has been altered subtly over the millennia to better suit the dark character of the Druchii and the chill desolation of their homeland.

The written form of Drukh-Eltharin is also rooted in the Eltharin language of Ulthuan. However, shortly after the Sundering, Malekith made the decision to radically revise the system of writing used by his subjects. Along with Hotek, Morathi and Furion, he created a new system of writing, using similar rune-forms to the original Eltharin language, but combining them together into complex sigils rather than arranging them in lines to form words and phrases. This method makes written Drukh-Eltharin more suitable for use in sorcery, as a whole spell can be encoded in a single symbol. The complicated rules of sigil-construction also render it almost impossible for anyone unfamiliar with the language to decipher a message of any significant length written in Drukh-Eltharin. Even among the loremasters of the Tower of Hoeth in Ulthuan, there are no more than a handful capable of understanding Drukh-Eltharin sigils containing more than a dozen or so word-forms. Mere human scholars find it difficult to accurately determine the meanings of even the most elementary phrases of this twisted language.

Like other elvish languages, Drukh-Eltharin makes great use of metaphor and symbolism. For example, orieur, the word for blood, also represents the colour crimson, as well as embodying concepts of birth and death: the beginning and ending of life. Drukh, the root from which the Dark Elves take their own name for their race, means harsh or merciless, but can also represent steel or a sharp blade. Druchii can be taken to mean 'the merciless ones' or 'the steel blades', among countless other phrases.

ways. This is generally viewed as an advantage over the crude languages of the lesser races. It is not uncommon for rival nobles to send each other letters which can be read in one way as beautiful poems and in another as dire and bloody threats. The Druchii are a subtle and cunning race, but they are not without honour. They consider oaths to be binding and even a noble would be hesitant to break the letter (if not the spirit) of a promise. But the Druchii language gives plenty of scope for loose interpretation of such oaths, especially in the written form. For the Dark Elves, there is no dishonour in circumventing a promise or a law through careful wording. Such cleverness is highly valued by the Witch King, for it makes his subjects' minds sharper and their hearts more cold and untrusting.

At the core of Drukh-Eltharin are the khydhani, runes which embody major concepts such as life, death, hatred and loyalty. Most Druchii family names are derived from one, two or three of these runes. For example, Cynthariour (meaning, roughly, 'Crimsondeath') is formed from the runes kynth and orieur. The names of the cities of Naggaroth are likewise formed in this manner. Har Ganeth means both 'city of executioners' and

S
r
u
c
h
i
i
i
i
i
a
n
g
u
a
g
e

'place of sacrifice', alluding both to the feared troops for which that city is famous and to its devotion to Khaine. A harganth is an altar dedicated to the Bloody-Handed God, where sacrifices are offered up by the witch elves.

The khydhani are supplemented and extended by a series of phonetic runes known as the harthani. These are used to spell out words and syllables that are not derived from the major concepts of the khydhani (or which are derived from those concepts but in a significantly altered form). For example, Moriyah Cynthariour would write her name using the harthani mu, okh, ru, dhy and akh for her first name and the khydhani kynth and oriour for her second name. She could form these into one or two sigils, with the placing of each element depending upon both context and personal taste.

It should be noted that runes are not always combined together into sigils. Drukh-Eltharin can also be written in lines of distinct runes as is the usual manner with the language of Ulthuan. However, this is generally regarded as juvenile and lacking in artistry. Dark Elf children learn to write their language using this method, but quickly progress onto forming proper sigils. The exception to this is the use of decorative flesh-hooks, which are usually in the form of single runes rather than sigils.

When pronouncing Drukh-Eltharin words, stress is usually on the first syllable for words of two syllables and on the second syllable for longer words, but this can sometimes vary depending on context. Proper names in particular can have unusual stress points due to their archaic origins (e.g. Naggarond and Malekith are both three-syllable words which are stressed on their first syllable, due to their original derivation from two-syllable words). Unusual stress patterns can be made more obvious in English representations of Drukh-Eltharin words by the use of apostrophes or hyphens, or even by splitting words up (such as in Har Ganeth or Klar Karond, to show the stress on both the first and second syllables of these very ancient city names).



The Khydhani - Major Concept Runes

Runeform	Name	Meanings
	Arha	darkness, night, shadow, stealth, grey
	Daro	memory, written records, stone, blue
	Drukh	merciless, harsh, steel

Runeform	Name	Meanings
	Elthrai	doom, hopelessness
	Elu	ending, denial
	Ganth	execution, sacrifice, dedication
	Har	place, abode, city
	Harath	youth, energy, jealousy, ambition
	Kar	despair, numbing cold
	Khadath	power over life and death, immense potency, the stars, change
	Khae	murder, slaughter, brass, bronze
	Khaladh	dragon, nobility, flame, yellow, orange



Runeform	Name	Meanings
	Kheyl	judgement, iron rule, punishment
	Khlar	eternal damnation, slavery
	Kuyl	sorrow, cowardice
	Kynth	cold, death, silence, wilderness, loss, black
	Kython	knowledge, serpent, potential danger, the ecstasy of pain
	Lakh	glory, infamy, victory over death
	Lath	anger, strife, storm, sleep
	Menlu	water, life, rain, green
	Minaith	skill, artifice

Runeform	Name	Meanings
	Nagh	chill, ice, pale
	Oriour	blood, birth, crimson
	Sarath	defiance, unyielding hatred, duty to one's superiors
	Sariour	sorcery, fortune/misfortune, cataclysm, the moon, silver, white
	Saro	eternity, infinity, intensity
	Senlu	speed, accuracy
	Senth	loyalty, strength in numbers
	Sheth	flight, wind, screaming, distance
	Thalu	hatred, vengeance

Runeform	Name	Meanings
	Than	hidden power, subtlety, feigned weakness
	Urith	destruction, conquest, warfare
	Yenlu	Chaos, opposing forces, similarity









The Harthani – Phonetic Runes









Note that some double-vowel elements are pronounced as diphthongs and some are not. Any double-vowel element not represented by a single runeform should be pronounced as two distinct sounds. In the case of three or more consecutive vowels, the first vowel pair that can be represented as a single runeform should be pronounced as such, while the remaining vowels should be pronounced as distinct sounds. For example, the name 'Uraeioth' would be represented by the harthani *ur, ru, dae, ith, okh, thar* and would be pronounced as something akin to "oo-REY-ee-awth" rather than, for example, "oo-RA-eiyee-awth".

Runeform	Name	Pronunciation	Representation
	Agh	to 'g' as 'kh' is to 'k'	gh
	Aibh	a very soft 'v' sound as in Irish medb	bh / bd / bt / db
	Ail	an 'aiyee' sound	ai

Runeform	Name	Pronunciation	Representation
	Akh	'a' as in cat	a
	Beth	somewhere between a 'b' and a 'p'	b / p
	Dae	'é' as in Spanish olé	ae
	Dar	somewhere between a 'd' and a 't'	d / t
	Dhar	'th' as in that	dh
	Dhy	'ie' as in die	y
	Eam	an 'eiyah' sound	ea
	Edh	'e' as in send	e
	Eil	an 'eiye' sound	ei

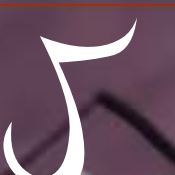
Runeform	Name	Pronunciation	Representation
	Eyl	'ai' as in nail	ey
	Fei	'f' as in feather	f / ph
	Gor	'g' as in gate	g
	Han	'h' as in hat	h
	Ian	an 'eeyah' sound	ia / ja
	Ikh	'i' as in kill	i
	Ith	'ee' as in tree	i / ii
	Khou	like 'ch' in Scottish loch, but harsher	kh / ch
	Ku	'c' as in cat	k / c / q

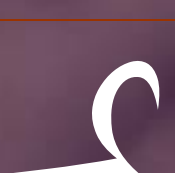
Runeform	Name	Pronunciation	Representation
	Loi	an 'oiyee' sound	oi
	Lu	'l' as in laughter	l
	Mu	'm' as in man	m
	Nu	'n' as in no	n
	Nui	like French 'oui'	ui
	Odh	'o' as in go	o
	Oer	'oa' as in oar	oe
	Okh	'o' as in not	o
	Our	'eu' as in French beurre	ou

Runeform	Name	Pronunciation	Representation
	Ru	a rolled 'r'	r
	Sham	'sh' as in ship	sh
	Sin	's' as in serpent	s
	Thar	'th' as in thorn	th
	Ur	'ou' as in tour	u
	Uyl	'ui' as in quill	uy
	Vekh	'v' as in victory	v
	Yeth	'y' as in yellow	y
	Zhul	like 'ge' in French rouge	z / zh

English – Drukh-Eltharin Mini-Dictionary

<u>English</u>	<u>Drukh-Eltharin</u>	<u>Runes</u>
“Death to the High Elves!” (a common Druchii battlecry)	kynthuithalkein	ᚵ ᚷ ᚷ ᚷ ᚷ ᚷ
1	kha	ᚵ ᚵ
10	eta	ᚵ ᚵ ᚵ
2	es	ᚵ ᚵ
20	ester	ᚵ ᚵ ᚵ ᚵ
3	tir	ᚵ ᚵ
30	tirter	ᚵ ᚵ ᚵ ᚵ
4	kan	ᚵ ᚵ ᚵ
5	deh	ᚵ ᚵ
6	sun	ᚵ ᚵ ᚵ
7	ut	ᚵ ᚵ
8	rou	ᚵ ᚵ ᚵ
9	daras	ᚵ ᚵ ᚵ ᚵ
altar	harganth	ᚵ ᚵ
and	na	ᚵ ᚵ
animal / creature	ead	ᚵ ᚵ
arm	drath	ᚵ ᚵ ᚵ
assassin (lit. ‘adept of Khaine’)	fiannakhain / menkhain (the former usually refers to an assassin within his temple, the latter to one pursuing a specific mission)	ᚵ ᚵ ᚵ ᚵ ᚵ ᚵ ᚵ ᚵ ᚵ ᚵ ᚵ ᚵ ᚵ ᚵ ᚵ ᚵ ᚵ ᚵ ᚵ ᚵ
axe	olthos	ᚵ ᚵ ᚵ ᚵ ᚵ ᚵ
beast / monster	kuron	ᚵ ᚵ ᚵ ᚵ ᚵ ᚵ
beastmaster (lit. ‘pursuer of beasts’)	eadukhar / kuroukhar / klathukhar (the first usually refers to slavemasters or junior beastmasters; the second only to those who specialise in the training of large and dangerous beasts; the third is a derogatory term)	ᚵ ᚵ

<u>English</u>	<u>Drukh-Eltharin</u>	<u>Runes</u>
before	uom	Ƶ ƶ ʌ
behind / following / pursuing	ukhan	Ƶ Ƶ ʌ ʌ
bell	kallu	ʌ ʌ ʌ Ƶ
belt	gilath	ʌ ʌ ʌ ʌ ʌ
bird / flying	nobh	ʌ ʌ ʌ
bird of prey	falkhu	ʌ ʌ ʌ ʌ ʌ
black ark (lit. 'sea-haven of black stone')	mourkhuylkyndar	ʌ ʌ ʌ ʌ ʌ ʌ ʌ ʌ
black dragon	khalakhynch	ʌ ʌ ʌ
black guard	aenarkynth	ʌ ʌ ʌ ʌ ʌ
blood / evil / sin	khael	ʌ ʌ
bow / archer	zhabat	ʌ ʌ ʌ ʌ
break / shatter	sainth	ʌ ʌ ʌ ʌ
Brides of Khaine	maibdethkhain	ʌ ʌ ʌ ʌ ʌ ʌ ʌ ʌ
bright / shining	las	ʌ ʌ ʌ
but / however	sib	ʌ ʌ ʌ
cauldron (of blood)	khaleos	ʌ ʌ ʌ ʌ ʌ ʌ
chainmail hauberk (lit. 'strength against death')	dalakoi	ʌ ʌ ʌ ʌ
chariot	kor	ʌ ʌ ʌ
circle / surrounding	hysh	ʌ ʌ ʌ
city of executioners	har ganeth	ʌ ʌ
civilian (a Druchii who is not currently armed or who is temporarily incapable of fighting; the term translates literally as 'cripple')	gharbhin	ʌ ʌ ʌ ʌ ʌ ʌ
cold one	kynead	ʌ ʌ ʌ
cold one knight	feinukynead	ʌ ʌ ʌ ʌ ʌ ʌ ʌ ʌ
corsair (lit. 'sea-raider')	mouraeth	ʌ ʌ ʌ ʌ ʌ
coven / convent of sorceresses	shobhian	ʌ ʌ ʌ ʌ ʌ
crag / rockface /cliffs	hag	ʌ ʌ ʌ
cuirass (breast and back-plate)	gaiedrugh	ʌ ʌ ʌ ʌ ʌ
Cult Of Pleasure (lit. 'seekers of pleasure')	khyrkanashaith	ʌ ʌ ʌ ʌ ʌ ʌ ʌ ʌ ʌ ʌ
dance	suith	ʌ ʌ ʌ

<u>English</u>	<u>Drukh-Eltharin</u>	<u>Runes</u>
dark crag	hag graef	1∞9570
Dark magic / the Dark Art (lit. 'knowledge of the sorceresses')	shobhuikyadhan	?2~79
dark pegasus	arshaith	∞5?I2
dark rider (lit. shadow-herald')	arhakhilir	†5∞↓T5
demon	kuyash	15∞?
door / gate	deash	-↓?
east (lit. 'sunrise')	oriyirah	∞5T5T5∞
eat / devour	tan	-∞2
erratic / unreliable / stupid	kyndul	1T2-5↓
executioner	ganthai	#I
eye	yir	5T5
face	aith	I2
female	babh	3∞~
frenzy / bloodlust / witchbrew	sarokhael	6Δ↓
Furion of Clar Karond	furionaiclarkarundu	055T∞2IF25∞2-5
greatsword	draich	-5I5
guard / wait	anarin	∞2∞542
guardian / defender	aenarion	72∞5T∞2
halberd	anarth	∞2∞5?
hand / agent	men	AN2
he / she / it	kal	1∞↓
heart	lir	↓T5
helmet	khandrugh	5∞245
herald	khalir	5∞↓T5
High Elves (lit. 'hated kin')	thalken	∞1N2
high rank / noble	fein	072
high sorceress	shobhein	?2~72
highborn / noble blood	oribhein	†~72
huge	koer	1∞5
hunting	karan	1∞5∞2

<u>English</u>	<u>Drukh-Eltharin</u>	<u>Runes</u>
sword	iarstil	ᚗᚋᚋᚋᚋᚋᚋ
Temple of Khaine (can refer to either a particular temple or to the cult as a whole)	hargankhain	ᚋᚋᚋᚋᚋᚋᚋᚋ
thinking	elehor	ᚋᚋᚋᚋᚋᚋᚋᚋ
tower of damnation	clar karond	ᚋᚋᚋᚋᚋᚋᚋᚋᚋ
tower of despair	karond kar	ᚋᚋᚋᚋᚋᚋᚋᚋᚋ
vambrace (forearm armour)	kuysakh	ᚋᚋᚋᚋᚋᚋᚋᚋ
warrior (a Druchii who is trained and ready for war at the present time)	urithan	ᚋᚋᚋᚋᚋᚋᚋᚋ
watching	yirraḥ	ᚋᚋᚋᚋᚋᚋᚋᚋ
west (lit. 'sunset')	elthyrah	ᚋᚋᚋᚋᚋᚋᚋᚋᚋ
witch elf (lit. 'bride')	maibd	ᚋᚋᚋᚋᚋᚋᚋᚋ
witch elf / priestess of Khaine (a very archaic term dating back to before the Sundering)	tulluch	ᚋᚋᚋᚋᚋᚋᚋᚋ

Sigil Construction

To demonstrate how Drukh-Eltharin sigils can be constructed, we shall return to the name of Moriyah Cynthariour. Born in the city of Har Ganeth into the noble House Crimsondeath, Moriyah was raised to prize the draich above all other weapons. Utterly devoted in body and soul to the Witch King and to Khaine, Moriyah has risen swiftly through the ranks of the Naggarothi nobility and now commands the Ghroind city garrison. The most proficient warriors of the city are tutored personally by her in the art of the draich and it is said that the Crimson Guard of Ghroind will soon be as famous as the Executioner regiments of Har Ganeth. Moriyah is proud of her achievements and would allude to them in the way she writes her name.

Let us first consider the elements that make up the name *Moriyah Cynthariour*:

ᚋᚋᚋᚋᚋᚋᚋᚋ ᚋᚋᚋᚋᚋᚋᚋᚋᚋ

Not only is *Cynthariour* Moriyah's family name (and therefore an unmistakeable sign of her noble birth), it also represents her skill in the arts of war. The second part of the name can also allude to the Crimson Guard, the elite regiment Moriyah is training in the use of the draich. When constructing a sigil to represent Moriyah's name, it therefore makes sense to start with the *kynth* and *our* runes, giving them a prominent position. These two runes are actually quite tricky to combine in a way that both looks good and is easily recognisable as representing *Cynthariour*. When combining complex runes like these, simple is best.



Now, we can turn our attention to Moriyah's first name. While her family ties are certainly important to her, Moriyah is aware that her skill and achievements are her own. Her first name will therefore be placed next to her family name, rather than below it (which would imply that her lineage was more important than her individual accomplishments) or above it (which would imply that she was ranked above the rest of her house).

It is usual when constructing sigils entirely from phonetic runes to begin with the most distinctive or prominent elements, which are usually the consonants, fitting the less prominent elements (generally vowels) around them. In the name *Moriyah*, the *m* and *r* elements are the most phonetically prominent. The runes *mu* and *ru* are therefore rendered larger than the other runes and are formed into a frame on which the other runes can be hung. The other prominent part of the name is the *iyah* sound at the end, not a common construction in the Drukh-Eltharin language. The runes that make up this part of the name, *dhy* and *akh*, are superimposed and used as a single element joined to the lower hook of



Putting the two parts of the name together gives:



- Shadowspite

Many and varied are the great floating fortresses known as black arks, the core of the Witch King's dark fleet, yet all of them are bywords for pain and misery to the lesser races of the world. The names of the greatest are known and feared from the Kasbahs of Araby to the Hinterlands of Khuresh. This quarter, we have uncovered the shared history of two of the greatest black arks ever to haunt the oceans.

Citadel Of Oblivion And Jade Palace Of Pain



In the history of the Druchii race, no other two black arks have had a more intertwined fate. Birthed together in the Sundering, these two vessels made their journey north together. For twelve centuries, they raided and made war together. But fate is not a kind mistress and, although the two ships were sisters, they were destined to be separated in the end.

Citadel of Oblivion and Jade Palace of Pain once faced each other across the same river. They were mighty fortresses that guarded the great Bridge of Shadows across the Shade River, a vital strategic point in the defence of Nagarythe. With these twin citadels straddling the raging torrent, none could cross into Nagarythe from the east without first assaulting them. And to defeat one fortress, the other would also need to be taken, for they were cunningly built so as to be able to support each other with bow-fire or by sending reinforcements across the fortified bridge that linked them.

As is common for two citadels in such close proximity, the lordly families that ruled them began to intermarry. Within a few generations, only one family controlled both of the defensive positions. House Khaithan ruled with an iron fist and a ruthless vigour that was so common amongst the proud people of northern Ulthuan at the time.

The two fortresses stood for many hundreds of years before the Sundering shattered the lands. As the great wave swept inwards from the coast, the sorcerers and sorceresses cast their magics and the two great castles were torn free from the bedrock. The Bridge of Shadows was smashed into pieces as the gigantic wall of water pounded into it and the two castles were buoyed upwards upon the churning waves. The twin Black Arks were born.

The Khaithan family settled soon afterwards in the new city that became

Black
Arks

known as Clar Karond, many of its members eventually becoming famous reavers and corsairs. House Khaithan soon gained a reputation as a fine naval family with a great tradition of loyal service to the Witch King.

For many years afterwards the Twins were seen in seas and oceans around the world. Every sighting heralded the destruction of a port town or village and the raiders made sure that at least a few survived to tell the horrifying story of the raid to generations to come. As the centuries passed, the two arks began to return to the familiar feel of family that had characterized the twin fortresses when they had stood upon land. Unusually for elven families, it was common for Khaithan women to give birth to twins. The first-born twins of each generation were given command of the two black arks upon their reaching an age of 200 years. The previous captains would then retire from the navy and live out the rest of their lives politicking in Malekith's court, attempting to raise the status of the family in his eyes. The new captains would continue their noble family traditions of naval combat and slave raids.

Just over eleven centuries after the Sundering, House Khaithan came under the careful scrutiny of Malekith and his historian, Furion of Clar Karond. The scholar-noble, jealous of the Khaithan family's growing power in his city, was looking for a way to be rid of the troublesome house. Intentionally or not, they challenged Furion's control of Clar Karond and threatened to reduce his influence at court.

Malekith was well aware of the Khaithan family's growing power and recognised the jealousy of Furion. He was also beginning to plan a new invasion of Ulthuan, but he needed a base of operations in Nagarythe to strike from and a new palace to rule from. He needed as well to keep the Khaithan family more closely under his watchful gaze so that their power could not grow unchecked.

So he summoned the captains of the black arks Citadel of Oblivion and Jade Palace of Pain, Failia and Korithan Khaithan, to his court in Naggarond.

Korithan, captain of the Jade Palace, was an accomplished corsair and had much experience in battle, both at sea and on land. He was tall, even for an elf, with sandy brown hair, a wind chapped face and piercing ice-blue eyes. A single thin scar ran down the right side of his face – the result of a harpy's malice many years before. He was well known as a calm and logical commander in battle and it was commonly believed that he would sacrifice his entire crew in order to gain advantage on the

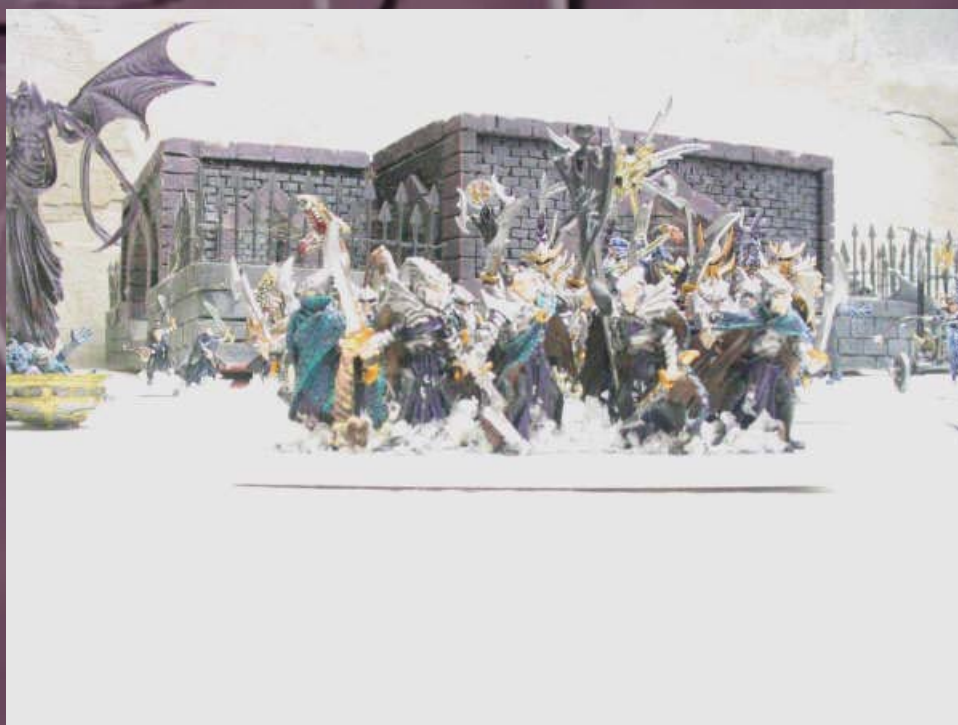

battlefield.

Failia Khaithan shared her twin brother's looks. However, in mind and spirit the two siblings were as different as night and day. Failia had the look of ambition and greed in her ice-blue eyes. Full of haughty pride, she would fly into a terrible rage at the slightest provocation, meting out cruel and bloody vengeance for any implied or even imagined insult. Her skill with sorcery was great and, under her command, the Citadel was extremely manoeuvrable in battle, supplementing the Jade Palace's bulk with faster-moving support.



Malekith decreed that a new age was beginning. He would lead the Dark Elves back to Ulthuan and reclaim his rightful throne. But he needed a base of operations. He would use the two black arks Citadel of Oblivion and Jade Palace of Pain to form the core of the rebuilt Nagarythi capital of Tor Anlec. Both captains would be honoured as wardens of the new city. They would move their entire house with them to Nagarythe and would have the honour of being among the first Druchii to set foot on their ancestral lands in the Great Reclamation. The court erupted into applause at the Witch King's words and Korithan and Failia were honoured at a special feast held that night.

Within a year, the invasion had begun. The Druchii armies pushed relentlessly inland from the ancient site of Tor Anlec, annihilating any Asur force that dared oppose them and reducing every settlement they found to carrion and ash. The Asur fell before them, unable to defend their lands with their armies already engaged in fighting the Dwarves on the other side of the Sea of Chaos.

Citadel of Oblivion was beached first, with Jade Palace of Pain directly to its seaward side. Each black ark was placed so as to make best use of its own unique features. Jade Palace of Pain had extensive holds and monster pens. Smaller vessels could easily berth inside her vast belly. Citadel of Oblivion, with its immense fortifications, was placed to landward so that she could act as a defensive position against any Asur counterattack. The Jade Palace would supply reinforcements to her twin and, if need be, take in supplies by sea.

Within two years, the Witch King himself presided over the ceremony to reopen the Bridge of Shadows, now joining the two black arks across a narrow inlet of the sea. Thousands of Asur were sacrificed so that the rebuilt bridge could be anointed with blood. Now the city of Tor Anlec was whole again. There were outer curtain walls of

great strength, set with battery upon battery of reaper bolt throwers. The Bridge of Shadows was completely enclosed and fortified with watchtowers and massive iron gates.

The rebuilding of Tor Anlec was a great achievement for the Dark Elf race. It heralded a new era. The Cult of Pleasure flourished and created great statues and other works of art for the enjoyment of the Druchii; the Temple of Khaine grew strong with the constant flow of sacrifices from the battlefields of Ulthuan; and Malekith once again ruled his ancestral lands.

But it was not to last. The warhosts of the Asur had at last given up all hope of reclaiming the Old World from the dwarfs; and Tethlis, the sixth Phoenix King, had reforged their shattered remnants into an effective fighting force. He vowed that no Dark Elf would live to pollute his land with their foul presence as long as he was king. Five-hundred years after the rebuilding of Tor Anlec, Tethlis launched a full scale attack upon lands of Nagarythe.

The hordes of the Asur were numberless and they attacked relentlessly, fighting with the cold determination of warriors that had seen too much bloodshed already in the war against the dwarfs and had returned to find their homes destroyed and their loved ones slaughtered by their dark kin. The Druchii fought back with all their natural skill and ferocity, but they were terribly outnumbered now that all the Asur had returned from the lands east of the ocean. Slowly but surely, the Druchii were driven back.

As Tethlis drove towards Tor Anlec, the city's wardens debated their options. Failia wanted to meet the enemy on the field backed by the power of her citadel and the magic she had developed over the long years. Korithan, always the calm and logical one, argued for staying inside the walls and facing the inevitable siege. Tor Anlec, he reasoned, could survive forever as long as her lanes to the sea were not cut off. In the end, Korithan prevailed and the twins began to make preparations to hold the fortress.

With the bulk of the Witch King's forces engaged far to the east, Tethlis sent a huge force of Asur against the city of Tor Anlec. Bolts and arrows turned the sky black as the Druchii based in Citadel of Oblivion fought ferociously against the tide of Asur that streamed up to the wall. Unnatural energy crackled through the air as mage and sorceress fought a death struggle for control of the winds of magic. The first wave of High Elves smashed itself against the walls of the city and fell back. Four times the Asur came on and four times they were thrown back. After the fourth and final assault, the Asur settled into siege lines and began to bombard the city with magic and siege weapons.

Cut off by land, Jade Palace of Pain began to take in supplies and fresh troops from the sea. Other Druchii were forced to take to the sea upon ships and sea monsters when the Asur began to raid the settlements around Tor Anlec. They quickly found a place in the defences of the city and were often used to send messages and gather supplies. As the siege wore on, Failia began to grow impatient. She saw that the Asur were stronger each day, while her defences weakened by the hour. Her brother believed that the Witch King would soon reinforce them, or at the very least lead an army to relieve them, but Failia could not wait and developed a plan of her own without her brother's knowledge.



She approached the bravest slave galley captains and enlisted their crew for a daring raid into the line of the Asur to destroy their siege machines. This would be the main thrust of her attack. Meanwhile, she would open the gates of the city and ride out with her knights and chariots to assail the High Elves with a brutal frontal assault. When the Asur redeployed to strike at the knights, then she would signal the corsairs to fall upon them from the rear, destroying their siege machines and then quickly trapping the High Elves between the two forces.

At midnight, the Druchii ships slipped out into the Sea of Chaos...

Dawn broke with the usual sniping between the siege lines and the walls of Tor Anlec. But then something happened that the Asur did not expect. The gates of the city slowly opened and the nobility of Tor Anlec rode forth: two-hundred black-armoured knights, carrying cruel lances and mounted upon great snarling reptilian beasts. Amethyst flame spewed from the outstretched hands of Failia Khaithan as her knights tore into the High Elves' front lines and the plain before the city gates turned red with Asur blood.

A great cry of horror ran through the High Elf ranks as the first black sail rounded the rocky promontory to the south of their position and hove into view. Behind it came another Druchii vessel, then another. The rear lines of the Asur host hurriedly readied themselves for the coming assault, knowing that they could not possibly hope to stand before the horde of Dark Elf corsairs that the black fleet must hold. Before the gates of Tor Anlec, Failia Khaithan let out a shriek of triumph, knowing her plan was about to unfold.

But the attack did not fall upon the High Elf army. Behind the black sails came a line of white ones emblazoned with the sign of the phoenix. The Asur navy, commanded by Tethlis himself, had ambushed the Druchii ships during the night and had captured almost every one of them. Her plan now in ruins, Failia turned her mount back towards the gate. But it was too late. Korithan, seeing that all was lost, knew that his first duty was to safeguard the Witch King's city. His sister's death was of no consequence to him now, especially as she had brought it upon herself by her impatience and lack of caution.

Cut off and outnumbered by hundreds to one, the Druchii knights fought like demons but were eventually overcome. Several noble houses were utterly extinguished, but it is still a source of pride among the Druchii that not one of the knights offered to surrender. Failia was the last to fall, cursing her twin brother's soul to damnation with her dying breath.

Even with the gates shut and barred, Tor Anlec was doomed. The ships that had kept it supplied for so many months were now in the hands of the enemy and the newly arrived Asur fleet could ensure that no other Dark Elf vessels could reach the besieged city. Again and again, Korithan had the city's sorceresses send telepathic messages to the Witch King, begging for aid. But Malekith could not spare a single warrior to the de-

fence of Tor Anlec. Korithan must hold the city with the forces already at his command, or die in the attempt.

Four months passed. Even with the most careful rationing, the city's food stores were almost exhausted. Korithan knew that he could not hold the city any longer, no matter what the Witch King commanded. His only choice now was between death and flight. There were no galleys upon which he could flee, but he still had one more vessel under his command: the black ark Jade Palace of Pain itself.

Korithan and his sorceresses withdrew to the innermost chambers of the black ark and sealed the portals behind themselves. Some of the city's inhabitants were fortunate enough to be within the walls of the Jade Palace, but the majority were manning the defensive walls of Citadel of Oblivion or elsewhere within Tor Anlec. Korithan abandoned them to the mercy of the Asur without a second's thought. The sorceresses groaned and wailed as they invoked the raw power of Chaos and the masonry of the colossal fortress began to shudder.

With a loud roar, the Bridge of Shadows broke apart and fell into the sea. Large sections of the city wall collapsed, burying hundreds of Druchii warriors beneath tons of shattered rock. The Asur, hearts filled with thoughts of vengeance, swarmed into the city. Whether out of cruelty and malice or simply a wish to end the war swiftly, Tethlis ordered his troops to leave no Druchii alive. Not even the children were spared and, from that day on, Tethlis was known as 'Khaelu' - 'The Slayer'. Perhaps overcome by shame at what had been done, the mages that accompanied the Phoenix King's army called down a tempest of white-hot flame upon the ruins, scouring the land of Ulthuan of any trace of Tor Anlec. Even the stones were obliterated.

Jade Palace of Pain escaped the destruction, carrying with it those pitifully few Dark Elves that had survived the fall of Tor Anlec. Its twin, Citadel of Oblivion, was no more. Korithan disappeared one night and was never seen again. Whether he fled the Witch King's vengeance, or whether it was the Witch King's vengeance that caused his disappearance, none can say. Jade Palace of Pain remained in the hands of the Khaithan family and went on to distinguish itself at the Battle of the Waves three years later, commanded by Ierkhan, cousin of Korithan and Failia.



Since the destruction of Citadel of Oblivion, the women of House Khaithan no longer bear twins.

Imdat's A u b l e

Imdat sighed, looking at the parchment with the inferiorly crafted scribbles on it. There were times when he cursed the stupidity of those beasts from the place they called the Empire. 'The Empire!' he scoffed at the name. How could they call that... that patch of land an *empire*. The chaos wastes he could understand – it actually described the destination: The chaos lived there and it was a waste of time to go there – even if you did survive you often came back with a nasty headache, an extra leg and a stump where your original one was cut off. Which would be all right if the new leg didn't appear in random directions. Trying to walk with a leg coming out of your stomach was mildly annoying at times.

Imdat's thoughts wandered to his home, Naggarothe – the land of the chill. It had been a long time since he had felt truly at home here, among the backstabbing and cunning of the rest of the Druchii. For that matter, it had been a long time since he had truly felt like a Dark Elf – save the pointy ears and a pre-occupation for torture, he had lost most, if not all, of the traits of those around him...

"Imdat? Hows that parchment coming along?" Imdat flinched at his superior's voice. But then again, everyone was his superior these days.

"Just fine... Really... just fine... Really... really... fine... just..."

But the elf had gone. They always went.

He didn't blame them. He didn't blame anyone anymore. Except for one person, and if he saw the pitiful excuse for a Druchii ever again, he'd probably forego the training of the Witch Elves, fly into a frenzy, and charge at him all fingers pushing. The dark elf's name was Dipskull Cryphmash.

When Imdat was young, he was in the same training group as Dipskull, who had gained his name through a rather strange incident during his naming ceremony involving a large bowl of green putty-like substance which his mother somehow mistook for dip. Consequently, Imdat and his fellow trainees would often tease the young Dipskull, dipping his head in the latrines a few times in harmless fun. It was not meant to offend – it was assumed that Dipskull would then go and take it out on his parents, as abusing your parents for your problems was the in thing at the time.

But Dipskull did not succumb to peer pressure, and he instead took to bodybuilding. On the day of the training group's graduation, Dipskull kidnapped Imdat and his fellow warriors, brought them to the foulest swamp in the land (also known as the Sewerage Treatment Plant) and dipped all of their heads in it, as payback. He was promoted immediately.

Imdat went to therapy for three years, which only served to worsen the problem. This was due to the fact that Naggarothe has no therapists as the rest of the world knows them: the closest thing to a therapist is a torturer

in a Druchii dungeon. Being chained to the wall in the worst Druchii dungeon and tortured once a week does not repair fears of being kidnapped and tortured, and Imdat is living testament of this. Only afterwards was the benefits of taking all of your problems out on your parents recognised, but by then the trend had faded and thus many druchii children were seen in the Torture rooms in the years following. These children were hardened by the treatment, able to take the greatest of blows, but were also demented for life and therefore many became the riders of the Cold Ones.

Imdat was by then a broken shell of a Druchii, but for some reason, unlike the rest of the torturees, his 'therapy' had improved his intelligence tenfold, but had also left him next to useless as a soldier, both his physical prowess and any semblance of cunning he may have possessed completely drained from his form.

At the same time, an opening for a job had opened inside the Druchii military. Ransom notes were being handed out to various races all the time, and of course, the responses were being recieved. Seeing as all of the 'beasts' in the Warhammer world would never be able to understand the Druchii language, someone had to do the translating. And only the most deprived, yet intelligent warrior in Naggaroth would do this. And therefore the task fell on the young warrior who was now not a warrior, and was quite intelligent and yet terribly disturbed and hated anyone whose name was Dipskull. And for anyone who hasn't caught on yet, his name started with an I.

Imdat Tauble stared at the parchment, took his quill, and started to translate.



His black cloak billowing in the wind, the figure rushed forward, using the night to cover his approach. The stone walls almost gleamed in the moonlight, but he could already smell the putrid stench of evil that emanated from there, contaminating the walls. As he scurried nearer, he felt a rising sensation in his stomach, the contents of his last meal about to reveal his locations to the alert druchii guards above. But he managed to hold his stomach down, and continued forward, his desperation and thoughts of revenge halting it's progress up his throat and slamming it back down to where it belonged. A flicker, and a black dagger came from the darkness, the figure readying the obsidian blade he had obtained especially for this.

He reached the wall of the watchtower, on the opposite side to the gate where the majority of the guards would be stationed, and began to creep around the circular wall. Edging along, he caught sight of the foul creatures of the night. The Druchii, as they called themselves. Three of them, around the gate. The figure continued to move forward, his heart beating in anticipation of what could be his final fight. He was out-matched in this mission, but he had to try. He had to regain at least some of the honour he had lost, even if it killed him to do so. He stomped his foot on the ground, just at the right strength to make the noise barely audible to the guards beyond. He edged back around the watchtower. And prayed. If more than one of those warriors came for him, he would raise the alarm and it would be over.

He listened for a sound, any sound other than his heart beating in his chest like a drum and his shallow breaths shouting at him like a pipe organ. *Buh-boom, Buh -boom, Buh -boom, whoosh, Buh -boom, whoosh, Buh -boom, tap...*

A footstep. And then another. After the third, he knew. Only one of the dark elves had come, thank Sigmar. He slowly peeked around the wall again, crouching to disguise his shadowy figure. The warrior was coming towards him, sword in hand, but his heart wasn't in it – there had probably been half a dozen other false alarms that night, and it was only when a black figure emerged from under him, a black knife piercing his heart as it tore through armour, cloth, blood and sinew, that he knew otherwise. The body fell to the ground, and like a tree in a deserted forest, nobody noticed.

The figure waited. Five minutes later, a second guard came. It was to be expected. Heart racing as he did so, the attacker sliced the throat of the second guard, moving in from the depths of the darkness and attacking from the side. He then moved forward towards the gate, spotting the last remaining druchii guard stationed right in the centre of it. The figure decided to put his training at ballistics to use, throwing his dagger and hitting the guard square in the head, the helm cut through as if it were a piece of parchment.

Corio Cartidae of Altdorf opened the gate and slid into the watchtower. He could feel his heart beating faster and faster, on the verge of exploding.

The scribe would pay.



The Empire text was written very poorly, even badly by Empire standards. As Imdat translated, he mused on his terrible days in the torture chamber and his lifelong hatred of Dipskull Cryphmash. He dwelt on the finer craft of a perfectly amicable torture, an art that he had learnt through experience in the chambers as a child, and which ones that he should use on Dipskull should he ever find him and capture him. He had been thinking through the sequence for over ten years, and was close to perfecting it. But he only needed to figure out one small part in the procedure which didn't seem right no matter which way he put it – should he be using a hook or the *Kar'sariour*, a small curved knife? Both were known for their pain-enhancing effects, but a hook would provide more pain for a shorter amount of time... or was that the knife – he couldn't quite remember...

While Imdat thought over this, he didn't think about what he was translating:

To Imdat,

I have found Dipskull for you, as agreed. However, he is in a rather high position and if it was found out that you or I were looking for him, we would probably both be disposed of quickly. Destroy this letter as soon as you read it, and make sure that no one else ever sees it. Meet me at the usual spot.

S.B.F.

Imdat finished translating it, folded the letter, put it in a nice new cream-coloured envelope (dark blue or black was preferred but due to the great Ink-maker's massacre a

year ago, ink was now too expensive for even the witch-king himself), sealed it with his translator's seal and dropped it down the chute that would carry it to his superior.

What occurred in the next few seconds is rather confusing, and for the most part, completely impossible to explain. As he let go of the envelope, he realised what he had done, and grabbed at it, but the envelope was too far down the chute to be caught. While his hand was there, however, his family ring expanded due to the heat in the chute just enough to fall off his finger, falling down the chute to the room below. It fell out of the chute and onto the floor, and since the room temperature was lower than that of the chute, the ring contracted again, bounced off the floor peculiarly and planted itself firmly in Imdat's superior's head, killing him instantly.

Meanwhile, Imdat ran down the stairs to see if he could get his envelope and ring back. He arrived there, and upon seeing the fruits of his ring's labour, he took the ring and the letter. He ran up the stairs to burn the letter in the fireplace. He ran downstairs to get some firewood. He ran up the stairs to burn the letter. He ran down the stairs to get some fire-making implements. He ran up the stairs to burn the letter. He ran down the corridor to find a room with a fireplace. He ran back to his room to get the letter. He ran to the other room to burn the letter. He then realised that nothing would burn in the room due to a magical ward that prevented it from burns, so instead he tore it up into little pieces, stamped on it a little, and then burnt the remains in the fireplace downstairs.

Imdat ran up the stairs so he could get his things before leaving – there was no place for him here once he had killed a superior officer. He started walking down to leave, but as he did, he heard some shouts from below and the patter of footsteps coming up the stairs. They had found the body. 'Damn' he cursed under his breath, knowing what was to follow – death.

With no way to go but up, Imdat continued up to the top level, where the head of the whole tower resided, although Imdat had never been told who this was due to his low rank. He reached the only room on the top level, and slowly opened the door. He then quickly closed it behind him, bolting it shut behind him. He turned around slowly, and saw the worst thing possible.

Dipskull Cryphmash.

"You!", they both said at once, both with equally sinister tones. Imdat felt the rage build up inside him, building to anger so intense that you could see it in his belly button if you looked. Suddenly, smoke started pouring out of Imdat's ears, and he cast his arms out towards Dipskull, huge bolts of dark magic tearing the other druchii apart. Imdat looked at the remaining mess of flesh and blood, the biggest body part he could see being a toe. The shock of the situation slowly registered. He was a sorcerer. He wielded magic.

"Hello?", He heard himself say, interrupting his train of thought.

"Huh? What is this. Why am I saying things I don't mean?" he replied to himself.

"You didn't say anything – this is Dipskull, you know, the guy you hate... why the hell are my arms so thin?"

"No that was me – I just said that, but I didn't mean to say it – I definitely didn't."

"Oh crap."

Suddenly, The door started shaking. The guards were forcing the door open.



Corio moved into the watchtower, drawing his weapon of choice – his broadsword. Pulling himself onto the wall, he inched towards the corner, and looked around. The corridor was empty. Something wasn't right – there should be another set guards in here, but they had disappeared. He inched down the corridor, his mind racing ahead of the situation – it had to be a trap. He reached the end of the corridor, and brought himself against the wall on his right, again inching along it. A great spiral staircase loomed in front of him. Up those stairs was his target. He longed to charge up them, but held himself back. He would not die through stupidity. He would destroy that translator, and only afterwards would he worry about the honour involved in the method.

Corio suddenly heard voices behind him, footsteps moving towards him from around the corner. The rhythm of their footsteps told Corio that they were running, shouting unfamiliar words in an unfamiliar tongue. But out of the exited tones and voices, he made out one word he had heard before and knew the meaning of: *Kynth*. Death. They had discovered the bodies outside. The trap had been set – there were probably a dozen other guards outside waiting for him to try and get out. Corio could feel the adrenalin rushing through his body, could feel himself ready for a fight. He gripped his weapon grimly, his fingers moulding to the coarse handle. He knew this feeling, he knew what he was about to do. So far, he had thrown away his honour, sneaking among the shadows, straining himself not to be seen or heard. Now he would fight.

Corio left the cold stone wall, the warmth reaching his legs as they pumped forward, the blood rushing through his veins. "FOR SIGMAR!!!" he yelled as he sprinted out towards the dreaded elves, but as he did so, he realised his mistake. Perhaps death through stupidity had been ordered after all. Corio just wanted to find the damned waiter and change it.

The four warriors that were 'headed his way' had already passed Corio, going towards the staircase as they went – it would seem that there was a problem upstairs – the assassination of higher officers was certainly not unheard of in the Dark Elf military. Corio's charge had come at exactly the right time for the passing warriors to turn around a spot him as a human (the mention of Sigmar had probably not helped either). Corio stopped dead in his tracks, as did the warriors, the surprise shocking both into an awkward silence.

Well, he thought, You wanted a fight, and a fight was what you've got.

The rest of his war cry died on his throat and all that came out was a polite cough.

And then he charged. At precisely the same time, the warriors ran forward, the sound of the twisted Druchii swords screeching out of their scabbards blending with Corio's yells into a hollow roar inside the watchtower. Corio moved off to the left at the last moment before confrontation, letting three of the warrior's swords swing wide as he smashed his

broadsword into the fourth, sending the weak elf's arm flying as his sword directed him, allowing Corio to serve the struggling elf an elbow in the face. The cold black eyeballs of the warrior receded into the back of his skull as the sword clattered on the ground, the elf's head following suit shortly after. *One down, about a hundred to go.*

Recovering from his missed attack, the next elf thrust his sword at the human's stomach. Corio jumped, the sword missing him completely as he came down on it hard, putting the warrior off-balance and allowing Corio to sweep the broadsword through his neck, blood flowing out and hitting the floor like red wine on a tablecloth.

The last two Druchii flanked him from the right, their swords ready to sweep into his flesh. Pushing the body of the headless warrior into the first, Corio blocked the overhead strike of the second before thrusting the sword uncontested through his stomach.

The last warrior had, by this time, managed to free himself of the corpse and came up behind Corio, thrusting his sword at the human's undefended back. The human suddenly jumped, performing a backflip in the air and landing to the side of the warrior. A second later, the final warrior was dead, a gaping hole in his heart as his crimson blood trickled out of the wound...

Corio listened for the other 96 warriors to come from upstairs, but they never arrived.

That was quick service. I'll have to give that waiter a tip.

Corio started to walk ever so slowly up the stairs, sword in hand and ready to stop at a moment's notice. It was not until he reached the penultimate level that he heard the voices from above. He continued to creep forward, wanting to get a better idea of the situation at hand. A rhythmic *boom* began to emerge, the source of which was unknown. Corio reached the last level, his heart breaking any speed barriers it had ever encountered before. He looked.

At least 50 Druchii were near the door, some using a log as a battering ram to break it down in front of them. Understanding dawned on Corio – someone was in there, probably with a knife at the throat of the commander. But such a thing was almost unheard of for the Dark Elves – why do it when you could just assassinate him in the middle of the night? The situation reeked of another intruder, and Corio didn't like it.

But then, he heard a word that he knew. And suddenly, he heard it so many times, that he knew what it meant. *Imdat*. His target. It had to be him in that room, with the knife to the commander. Which made Corio's life very difficult. And most probably, very short. Corio's confidence lifted as he thought of how he would die – honourably and courageously. He would never succeed his mission, but he would die where he belonged – in battle.

The door finally gave way to the guards, splintered wood falling to the ground and immediately flattened by the horde of elves flying in. Corio lifted his sword to the ready position, ready to spill blood for the emperor for the final time.

- Imdat

RPG Heroes Building

Characters are a vital part of any Roleplaying Game (RPG for short), and the RPG here on Druchii.net is no exception. In this article I hope to assist any new player, and perhaps some veteran players, in the creation of their RPG character.

There are, I think, two major ways to play an RPG. One way is to have a character that exists for the sake of gaining items and becoming powerful. I think that, while this is all well and good, it misses out on something that is, to me, the most enjoyable aspect of an RPG (particularly the Druchii.net RPG). That aspect is the creation of a memorable character with a distinctive personality. With respect to the Druchii.net RPG, this means creating an interesting member of the Dark Elf race.

In doing this, there are many things to consider. First things first, before you even put pen to paper or, more accurately, fingers to keyboard, you should think for a while about your character. Who is he/she? Where did he/she come from? What does he/she look like? Just mull over the character for a while, and try to understand this elf you have just created. It's best to go into the creation of a character with a good idea of who he/she is. It makes it easier for you to 'get into character' and track the character's adventures.

Now it's time to put pen to paper (fingers to keyboard). The first thing to do here is to write an account of the character's appearance. Let's take a look at an example:

"Durieth is short for one of his race, but no less slim and agile. He looks quite fragile, though graceful and subtle. He has no distinguishing face features, plain coloured and shaped. His eyes are as his hair, raven black. He will usually seem charming and open to the ones he meet, playing on his savage Druchii beauty."

This is the description of a old character from the RPG Group 3. Notice how the description is good and vivid, providing the reader with a mental picture of the elf. Just by reading this, the reader can develop a mental picture of a graceful but short elf, who has a habit of being charming and using his looks as a tool. The character is memorable. Imagine how forgettable the character might have been if the appearance were written as:

"Durieth is slim and agile, although he is shorter than other elves. He has black hair and black eyes."

Were the description written like this, the reader will not form as good a mental image of the character. The character becomes very forgettable.

Let us next look at the character's history. Like the appearance, the history should be good and interesting. It doesn't need to be dramatic and extraordinary (although this can help), but it should allow the reader to become interested in the character. It should allow YOU to become interested in the

character. Let's take a look at Durieth's history:

"Durieth is a lowly son of a noble of the House Ysiri. He is decadent in the extreme (even for a Dark Elf), always appearing relaxed and careless. He has a wicked tongue, able to manipulate others to achieve his desires, but does ultimately not care for anybody but himself. His unquenchable appetite for fine wine and women to relieve him from his daily imprisonment of boredom has led him into great debt and scorn in his family. He once slayed a hundred unarmed slaves of the family in a single night in the attempt to add flavour to his existence. Years of meaningless activities has numbed his lust and sense of living, causing him to be more and more dangerous to his surroundings. He will stop at nothing to get his blood pumping.

These ethics of living, combined by the need for gold to pay for his highly luxurious life has led him to become a Druchii mercenary, lending his dubious loyalty to the highest bidder. He casually takes on any task, no matter how dire and perilous it may be."

Notice that this account gives some information about the character himself as well as his background. It allows the reader to get a real feel for what it would be like to meet this guy in a bar, and the sorts of things he might tell you over a mug. Notice that the history itself isn't particularly note-worthy. It's pretty average, in fact. But it still seems interesting. Of course, you can have a less normal character as well. Here's the history of another character from Group 3, Sheen Blackblade.

"Sheen was originally a High Elf, trained in the ways of a Swordmaster. What seems like ages past, he felt a dark calling, and abandoned what he knew for what he desired. The way of the Dark Elf was his way. The transition was an easy one, and as yet, no one knows of his past, and Sheen wants to keep it that way. He hates the High Elves as much as any Druchii now, and prejudices would just get in the way. He was always tall, lithe and athletic with broad shoulders, and his training as a swordmaster built on these qualities. Although it has been a long time since he has wielded a weapon of the refinement of the swordmaster blades, and his skills have become.. rusty. He signed up as a warrior just recently, and his previously learned skills are returning to him. Old habits die hard though, and he never likes using a shield, preferring to wield his weapon in two hands, and use his skill with the blade and high agility along with his natural speed to evade and deflect attacks. With a blade in his hand, Sheen feels invincible, and he wields his swords with a gracefull, but deadly beauty."

We have a very interesting history behind the character. It also tells a bit about the character himself, and gives more of an idea of what he's like. But note also that it's not a supremely detailed history. That's fine: you don't need to write your character's entire history out in full, just give the reader an idea of who he or she is dealing with.

I hope that covers all the essentials of creating your RPG character. Don't be discouraged if this seems difficult: it's can be much easier than it looks. Remember that the point of the RPG is to have FUN. Creating an interesting and realistic character can enhance the experience and make it a more enjoyable experience. I look forward to seeing you in the RPG and the world of Warhammer in general! Stay tuned for other RPG articles in future.

- Sneaky



Sruchii .net Quarterly

End of Part 2