

ISSUE 46 \* MAY/JUN 1987  
ISSN 0889-2164

# Different Worlds

*JOURNAL OF ADVENTURE GAMING*

\$3.00

AUSTRALIA \$4.95

U.K. £2.50

SCIENCE FICTION SPECIAL

elli's 85©



YOUR NEXT MISSION...



# Desert Sun

Israeli intelligence reports that Khaddafi is building his own A-bomb at a secret lab in the Libyan desert. A Delta Force Team (with help available from the Sayaret Matkal, Israel's counter-terrorist force) must defuse this potentially catastrophic terrorist weapon before its completion, and they must do it without giving Khaddafi a propaganda weapon in the process.

*Delta Force: Desert Sun* also includes suggestions for additional missions into Khaddafi's Lybia and variants of the main mission. Other features include: details on handling and defusing nuclear weapons, desert survival training, templates for Libyan military forces, a dossier on Muommar Khaddafi, information on Libyan involvement in international terrorism, and descriptions of new equipment.



# The Hole Delver's Catalog



Are you tired of going into a shop and finding a sword, a shield, a pack, a tent, or an-other generic piece of equipment? Wouldn't it be nice to get hold of something *special* for a change?

Then, ladies and gentlemen, you need the handy *Hole-Delver's Catalog!* It's chock full of notions you've never seen before and never ever knew you needed...until now, that is! An almost unbounded supply of unique and utilitarian items — some of them useful! Your satisfaction guaranteed or...or... or else!



*Silas T. Hackster*

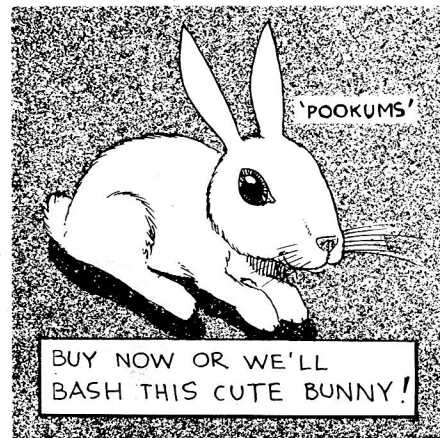

Not Just A Catalog...  
It's An Adventure!



TASK FORCE GAMES / 1110 N. Fillmore / Amarillo, TX 79107



# Editorial

The Adventurer

## STATUS REPORT

*THE LAST* time I gave you a status report was back in early 1986 (see DW41). It's time I gave another one.

**MERCENARIES, SPIES & PRIVATE EYES:** New boxed edition now available. *Stormhaven*, its first module, is also available thru Sleuth. We are now soliciting submissions for solo adventures and other materials.

**IDENT-A-KIT 1: FINGER-PRINTS:** A new concept in role-playing accessories. This boxed set contains a detailed history of fingerprinting and methods of classification, hundreds of "peel & stick" fingerprints, and a 3x magnifying glass. Designed to be used with *MSPE* and other contemporary role-playing games. Due out this month. Kit 2 will be *Mugshots*, featuring dozens of hair styles, eyes, noses, mouths, and jaws to create thousands of faces of men and women.

**EMPIRE OF THE PETAL THRONE:** For once one of Gigi's prognostications is correct: The contract has been signed and Professor M.A.R. Barker's *Tekumel*

role-playing system will appear from us. We plan to first publish the original *Empire of the Petal Throne* in the next month or two and then the *Tekumel Sourcebook* later this year.

**THIEVES' GUILD:** New binder edition is scheduled for release late this year.

**GASLIGHT:** The next *Consulting Detective* supplement is still in the works but is expected to be released sometime in the next few months.

**OTHER PROJECTS:** *Legendes*, an English-language edition of a Celtic role-playing game from France; *Danger Island*, an adventure-mystery boardgame for the whole family; *Sorcerer's Cave*, adventure game featuring a geomorphic board; *The East End Adventures*, supplement for *Consulting Detective*; *Chinatown*, supplement for *Gumshoe*; and a *MSPE* gangster module set in the thirties.

*Half of the above is leftover from last year, but then we were being deliberately optimistic. We expect to be this year also.*

Happy gaming,

*Tadashi Ebara*

This issue dedicated to:  
**ANDY WARHOL**  
(1930?-1986)

**PUBLISHER'S STATEMENT:** Different Worlds Magazine is published bimonthly by Sleuth Publications, Ltd., 689 Florida Street, San Francisco CA 94110. Contents copyright © 1987 by Sleuth Publications Ltd. All rights reserved. Reproduction in whole or in part is forbidden without prior written consent from the publisher. Address all correspondences to Different Worlds, 2814-19th Street, San Francisco CA 94110. Advertising rates and trade information available upon request. Basic black & white ad rate is \$200/page. Different Worlds and Sleuth Publications, Ltd., assume no responsibility for its advertisers. Submissions for publication are accepted and encouraged. Articles should be double-spaced with 1" margins all around. Artwork should be accompanied by a self-addressed stamped envelope for their return. All submissions become the property of Sleuth Publications, Ltd., rights revert to author/artist upon publication or rejection. Remuneration for articles is 1¢/word of published matter. Artwork is paid at a \$20/printed-page rate (i.e., ¼-page is paid \$5). Color covers are paid \$75.

**SUBSCRIPTION INFO:** A one-year (six-issue) sub in the U.S. is \$15. Foreign subs are \$22 by surface mail, \$33 by air. The number next to your name on the mailing envelope is the last issue of your sub. For address changes send at least thirty days in advance your new address, old address, and the day new address is in effect.

**OVERSEAS AGENTS:** AUSTRALIA: Ventura International, 193 Clarence St., Sydney 2000. JAPAN: Post Hobby Co., Ltd., 26-5, 5-chome, Sendagaya, Shibuya-ku, Tokyo. UNITED KINGDOM: Sleuth UK, 89 Victoria St., Liverpool L16 DG.

**EDITORIAL STAFF:** Tadashi Ebara, editor. Gary Grady, Suzanne Goldberg, Dave Arneson, associate editors. John T. Sapienza, Jr., Gigi D'Arn, contributing editors. Denise Osborne, proofreader.

PRINTED IN THE U.S.A.



# Contents

Issue 46  
May/Jun 1987

## SCIENCE FICTION SPECIAL

Cover Illo:

# THE SCOUT

By  
Kevin C. Ellis

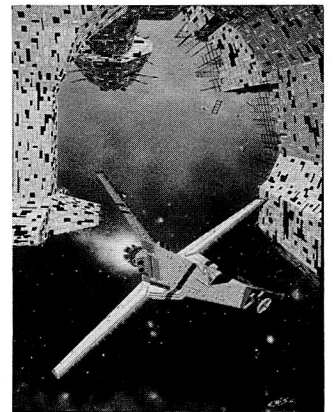

Page

Star Trek Games by Thomas A. Grant . . . . .	6
<i>Or how to get yourself into the Final Frontier</i>	
COPS! by Terry McInnes . . . . .	10
<i>A Traveller Police Character Generation System</i>	
Adventuring in the World of The Morrow Project By Joseph Benedetto, Jr. . . . .	16
Maps & Character Stats for Using the Solo Jade Jaguar as a Gamemastered Adventure by David L. Arneson. . . . .	22
<i>For Gamemasters Only</i>	
Disease In Glorantha by Oliver Dickinson. . . . .	36
<i>A RuneQuest Causerie</i>	

**JAMES BOND 007**

**THE SOUNDS OF DANGER**

By  
**Robert Rosenthal**  
Module between  
pages 24 and 25

## REGULAR FEATURES

- 3 Editorial
- 9 Conventions
- 26 Game Reviews
- 42 New Games In Print
- 44 Book Reviews
- 46 A Letter from Gigi

## CARTOONISTS

- James L. Shipman 3
- Richard A. Tomasic 34
- Lori Walls 9



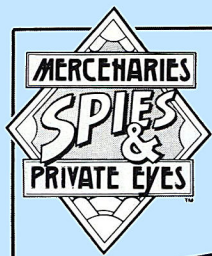

THE FIRST  
MSPE  
MODULE



**THUNDER SHATTERS** the stillness of the night while hulking monsters walk Savage Island . . . well-paid mercenaries stalk the renegade Tigers in a race to prevent the theft of confidential industrial secrets . . . a KGB officer is found dead of a strange disease, clutching a note that suggests a unsuspected spy lurks inside Stormhaven. . .

**STORMHAVEN** is the setting for contemporary role-playing game adventures. Set on Savage Island in Lake Champlain, Stormhaven is the fine mansion owned by Kenneth Allard, president of Allard Technologies. Life at Stormhaven is lived in a grand style, and the secret work that goes on in the laboratory beneath the mansion is innovative. Many interesting guests (most of them with more than one reason to visit) can be found in Stormhaven.

**STORMHAVEN** contains two books: one of descriptions of buildings, people, procedures, and adventures, the other of maps and floorplans. Stats for *MSPE* are included. As an added bonus, enclosed are 23 *Cardboard Heroes* for the main characters and security teams, created exclusively for this adventure!

SL-3301 Stormhaven . . . . . \$10.00

Available thru *Sleuth*. Use order form on page 39. Dealer inquiries welcome.

# SUMMER SPECIALS LIMITED TIME OFFER

Prices good only until 8/31/87

Use order form on page 39.

## Summer Special 1: THE COMPLETE THIEVES' GUILD

*Thieves' Guild Boxed Set  
TG2-10*

544pp of material including:  
64 major encounter descriptions and  
15 major scenarios

A \$75.75 value for

**Only \$44.95**

*Special discount postage & handling  
rate: \$4.50. See ad on page 21 for description of entire line.*

## Summer Special 2: THE COMPLETE THIEVES' GUILD MODULES

*TG2-10*

436pp of material

A \$60.75 value for

**Only \$36.95**

*Special discount postage & handling  
rate: \$3.50. See ad on page 21 for description of entire line.*

## Summer Special 4: COMPLETE GAMELORDS' TRAVELLER MODULES

*The Undersea Environment  
The Drenslaar Quest  
The Mountain Environment  
Ascent To Anekthor  
The Desert Environment  
Duneraiders  
The Drexilthar Subsector  
Wanted: Adventurers  
Startown Liberty  
Lee's Guide: Volume 1*

528pp of material

A \$62.50 value for

**Only \$37.95**

*Special discount postage & handling  
rate: \$3.50. See ad on page 46 for description of entire line.*

## Summer Special 3: COMPLETE JUDGES GUILD CAMPAIGN HEXAGON SUB-SYSTEM

*Village Book I  
Village Book II  
Castle Book I  
Castle Book II  
Island Book I  
Caves And Caverns*

384pp of material

A \$18.23 value for

**Only \$15.00**

*Special discount postage & handling  
rate: \$2.50.*

Just when you thought it was safe to go back into  
The Dungeon-----

**SECOND DAWN** arrives!

Now live the **THULIAN** adventure!

**The First FRPG designed for MATURE audiences!!!  
With over 800 New Spells, 40+ Player Characters,  
Many NPC's, and Monsters and Artifacts galore!!  
Adaptable to MANY other game systems, too!!  
Follow the Path to New Worlds of ADVENTURE!  
A GAME THAT PROVES ROLE-PLAYING CAN  
CHALLENGE & EXCITE YOU!!!**

**The First of a New Series of Thrilling Games!**

Order Now, only \$11.95, (plus \$2.00 Postage/Hand'ng)

N.Y. Residents, PLEASE add applicable sales tax!

**rba ENTERPRISES**

**P.O. Box 7**

**Ridgewood, N. Y. 11386-0007**

# Have you switched yet to the #1 role-playing system?

That's right . . . **RuneQuest** was voted "best role-playing system" at Games Day 5, Great Britain's version of ORIGINS! And that was even before the new modules were available! Think of how much fun you can have playing **RuneQuest** NOW.



We are committed to supporting this tremendously enjoyable role-playing system. By the time you read this message, we'll have even more modules and supplements for you. It's growing rapidly into the #1 system *all over the world*. Spending an evening in, say Bangkok, without knowing how to play *RuneQuest* could be embarrassing (not to mention boring).

## BRAND NEW!

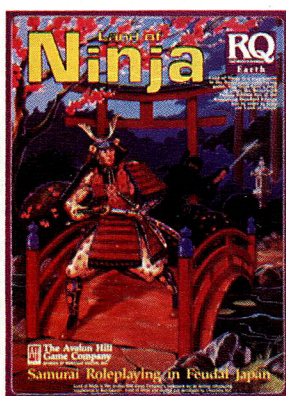

Here's what's in the complete **RuneQuest** system to date:

- **Deluxe RuneQuest**—the complete game with 3 magic systems, new skills, new spells, and new combat rules . . . **\$38**
- **Monster Coliseum**—arena combat and chariot racing of the early Roman era . . . **\$16**
- **Human Adventurer**—not a game, but a playing-aid supplement for scorekeeping . . . **\$10**
- **Nonhuman Adventurer**—includes scoresheets for 16 of the most imaginatively unique characters possible . . . **\$10**
- **Vikings**—the gods, giants and monsters from viking legend; a fascinating blend of history and myth . . . **\$21**
- **Gods of Glorantha**—introducing hundreds of new skills, spells and sorcery in this gloranthan supplement . . . **\$18**
- **Griffin Island**—includes brand new map, and devices freeing the gamemaster to join in the play himself . . . **\$16**
- **Land of Ninja**—Samurai role-playing in feudal Japan . . . **\$16**

Available at your favorite game store, or direct from:

For quick credit card purchasing call **TOLL FREE** 800-638-9292



## The Avalon Hill Game Company

DIVISION OF MONARCH AVALON, INC.  
4517 Harford Road ★ Baltimore, MD 21214

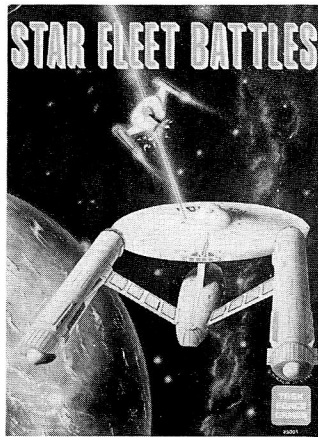

COMPARING STAR Trek games is difficult, since they span the range of gaming possibilities, from computer gaming to boardgaming to role-playing. There is a single standard of judgment, however, which works for them all: How effective is any given game at capturing the appeal of Star Trek, that undefined "something" which keeps us watching the show, even in endless reruns?

## STAR TREK GAMES

### Or how to get yourself into the Final Frontier

By Thomas A. Grant

**M**uch of what I say will be based on what I personally find appealing about Star Trek, but I'm sure that many of you will share my feelings. In sum, if I can't seek out new life and new civilizations and boldly go where no man has gone before, then something important is missing from a Star Trek game.

#### THE BOARDGAMES

As with the vast majority of boardgames, the Star Trek boardgames (and there are many) are mostly simulations of military conflicts. The runaway bestseller of all Star Trek boardgames is Task Force Games' *Star Fleet Battles*, a complex simulation of everything about starship combat, including Orion suicide ships (remember that from "Journey To Babel"?), cloaking devices, and clever maneuvers only the noblest of Federation commander can pull off. If you always wanted to captain a Federation heavy cruiser in combat against a Klingon battlecruiser, then this is the game for you. Task Force has gone a few steps further by introducing starships and alien species never before seen by Star Trek fans.

Unfortunately, I have problems with much of this. First, I always feel disoriented when playing *Star Fleet Battles*, since there are many unfamiliar ships. Certainly Star Fleet needs more than the *Enterprise*-like exploration cruisers, but futuristic versions of aircraft carriers? Federation ships firing missiles? And new generations of super-dreadnoughts which make the *Enterprise* look like the Caspar Milquetoast of the galaxy? And who the hell are the Lyrans, Hydrans, and Andromedans?

*Star Fleet Battles* is even more disorienting for the same philosophical difference I have with all the purely militaristic Star Trek games: the message of the Star Trek TV show was that brute force was a simple-minded, uncivilized, and inhumane solution

to problems. Force was used only as a last resort, as was the case in the episode "Balance Of Terror," in which Captain Kirk played a lethal cat & mouse game with a Romulan warship. If the *Enterprise* had lost the battle, the Romulan ship would have reported that Federation defenses were weak, and the Romulans would have started a new war against the peaceful, civilized citizens of the Federation. A game based purely on starship combat—a rare occurrence in itself and always something of an aberration—loses something important about Star Trek in the translation.

Still, *Star Fleet Battles* and its kin, Gamescience's *Star Fleet Battle Manual* and FASA's Starship Duel series, can be a lot of fun—if you enjoy the nail-biting suspense of starship combat. *Star Fleet Battles* presents many fascinating tactical problems to those with a wargamer's heart, but I suggest that, due to the extreme complexity of the game, you begin with the excellent *Introduction to Star Fleet Battles*, a much simpler game which takes you step-by-step through the basics of the larger, more complex game. It has a fun format, too, in which you begin as a Star Fleet cadet and work your way through the scenarios to "graduation." Each new scenario introduces you to another set of rules, and after several games you will have mastered the complexity as well as the tactics needed to be a good player.

If you enjoy something simpler, get one of the Starship Duel games from FASA, which will allow you to wage fast and very dirty fights between two ships. The combat system is simple, and you'll want to play another quick game as soon as you've finished one. FASA has manufactured two sets, each with two ships, and with a little modification you can

play with other classes of starships, too.

Gamescience's *Star Fleet Battle Manual* is a simpler version of *Star Fleet Battles*, but since you're more likely to find players for the latter, I suggest you invest in *Star Fleet Battles*. There's more material published for *Star Fleet Battles* too, from new scenarios to new ship classes (if that intrigues you).

Of all the boardgames, by far the best at duplicating the spirit of Star Trek are West End's three entries into the field, *The Enterprise Encounter*, *Star Trek: The Adventure Game*, and *Star Trek III: Exploring New Worlds*. Both *The Enterprise Encounter* and *The Adventure Game* walk the players through the plots of the Star Trek shows—with changes, of course. In *The Enterprise Encounter*, two to four players attempt to save the *Enterprise* and her crew of 430 from the deranged Trelayne, self-styled Squire of Gothos (remember him?), by making many life & death decisions. In my favorite of the two, *The Adventure Game*, you can play the captain of a Federation or Klingon exploration mission in uncharted space. In both games, when faced with familiar situations, expect the unexpected. What would happen if the crew of the *Enterprise* told Trelayne to buzz off and leave them alone? And how would the Klingons have handled Charlie X?

*Star Trek III* offers three games in one. First, you can try to bring a fellow starship captain to justice for breaking the Prime Directive and setting himself up as the satrap of a planet in the equivalent of the Dark Ages. In this very easy to learn but hard to win game, you must don the garb of the Merry Men to bring peace to this troubled planet. The idea is fairly corny, but the game has enough fun and suspense to sus-

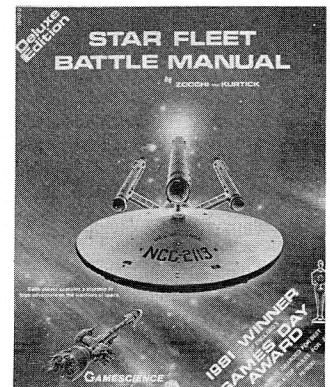

tain interest. The second mini-game, "Free Enterprise," pits the crew of the *Enterprise* against their Klingon counterparts in a trade war. Can Kirk and his gallant crew beat the Klingons in the ruthless game of buying and selling thrint whistles and gleebers? I would suggest this game only to those with Mammon's heart and a lot of patience. The whims of the market are capricious and it is difficult to beat the Klingons at ruthless dealing and double-dealing, especially when they have pirates patrolling the space lanes.

The best game in *Star Trek III* is the Kobayashi Maru simulation from the second Star Trek movie, in which you must journey into Klingon space to save the crew of a wrecked freighter. This game is challenging, exciting, and a real knuckle-buster. You'll play this again and again, if only to get close to winning.

#### COMPUTER GAMES

The very first computer game was based on Star Trek, in which you piloted the *Enterprise* through different quadrants of space to stop a Klingon invasion. Although this relatively simple program seems primitive in comparison with the computer games of today, there is still some charm about the old Star Trek game in its many incarnations. By far the best version of this game was *Super Stellar Trek*, in which not only did you warp through space and fire phasers and photon torpedoes at hapless Klingon ships, but you could also explore planets for dilithium crystals, fly around (and, if you were very courageous, through) black holes, and test the Federation's new death ray if you got into a particularly difficult pinch.

Unfortunately, there have been almost no Star Trek computer games since then. A version of the arcade Star Trek game is available for home computer, but like all shoot 'em ups, the arcade game loses its appeal quickly. Two games, *Star Fleet* and *Cosmic Encounter*, look suspiciously like Star Trek simulations, but the

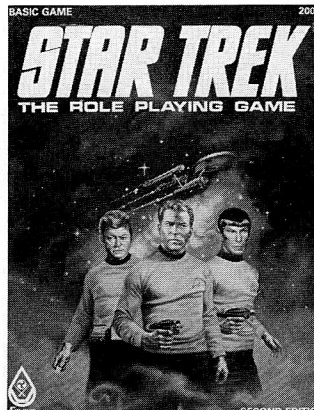

names are changed to protect the manufacturers from paying beautiful royalties.

Fortunately, there is one excellent Star Trek "adventure game," *The Kobayashi Alternative*. As in all "adventure" or "interactive fiction" games, you type in commands and the computer tells you the result. In *The Kobayashi Alternative*, you play all of the *Enterprise* crew as you investigate several inhabited planets in search of a lost Federation exploration ship. There's a lot of intrigue and many puzzles to solve, and best of all, it actually feels like a Star Trek episode! You can even take a walk around the *Enterprise* to get the feel of the vessel you're commanding as Admiral Kirk (alias, you).

With all the amazing talent in the software field, I've always been surprised that no one has really taken on the challenge of making a superior Star Trek game. *The Kobayashi Alternative* is the first, but I'm sure that the people responsible for such programming marvels as *Ultima*, *Wizardry*, *The Bard's Tale*, *Sundog*, and the like, might be tempted to write a game in which, in full color and with sound effects and music, you can seek out new life forms, etc. I'm sure that the biggest obstacle to this is not the combined Romulan-Klingon menace, but something even more insidious, copy-right problems. Still, a superior Star Trek game might be an enormous money-maker. . . .

#### ROLE-PLAYING GAMES

Role-playing games have greatly matured since the first *Dungeons & Dragons* rules, and for practically every field of fantasy, science fiction, mystery, horror, or adventure novel or film, there's a role-playing game. The only Star Trek role-playing game, made by FASA, does an excellent job of simulating the show and the movies, while capturing that special Star Trek appeal I discussed in the beginning of this article.

As in all role-playing games, you need a referee (who plots the scenario, creates gamemaster char-

acters, and tells the other players the consequences of their actions) and several players. Having more than one or two players is important, since it's hard to play an entire starship crew or even a landing party yourself. (It's hard enough to switch between Scottish and Russian accents when playing the standard *Enterprise* crew!) For maximum enjoyment, you need several players, for added brainpower as well as characterization. After all, we grew to love Star Trek for the characters, so if you choose the role-playing game, you will get the greatest enjoyment by strengthening the characterization of the imaginary people whose persona you will borrow for a few hours.

FASA's basic *Star Trek* role-playing set is easy to learn, though it may be a bit menacing for beginners. Don't panic: role-playing is easier than it looks. There are lots of rules, but you don't need to memorize all of them. Your most important job is to run your player-character. If you understand that in each skill area (such as Navigation or Vulcan Nerve Pinch) you have a certain percentage chance of success (such as 45% each time you try a nerve pinch), then you will do just fine. After all, the play's the thing.

If you still have problems, FASA provides a good introduction to the game for beginners, and walks the player through the creation of a sample character, Lee Sterling. When you create a character, you make their career decisions as they advance through the Star Fleet Academy, determining whether they will become an absent-minded science officer or a lantern-jawed starship captain. If you want to play the crew of the *Enterprise*, then their character descriptions are all available in the basic set. If you have perverse tastes, FASA even has produced supplements which tell players how they can create and run Romulan and Klingon player-characters!

FASA has also done us all a ser-

vice by providing comprehensive and well-organized background material on the Star Trek universe. Although I've been a fan for years, I can't always remember the names of some of the medical thingamajigs in McCoy's medical pouch, or all the extraordinary abilities of Vulcans. There is also an excellent section explaining what is expected of starship crews—when to fire on suspicious alien vessels, in what cases the Prime Directive applies, etc. The manuals are well-organized, and it's usually a simple task to find some rule or fact which you can't remember.

FASA also produces a cornucopia of pre-written scenarios, minimizing the work for already-exhausted referees. One of the worst problems for me is finding the time to write a scenario (which takes at least several hours to do well), so pre-made scenarios are a godsend. Most of FASA's Star Trek scenarios are good, and some are excellent. Most have a level of intrigue, a mystery to unravel, and a chance for real adventure in the final frontier. A good example is *The Vanished*, which pits the *Enterprise* crew against a difficult puzzle: where did the scientists in a deep-space research station go when they suddenly disappeared? And what are those strange, slug-like aliens slithering around the abandoned research facility?

In some of the scenarios, FASA picks up plot lines from the TV show: for example, the Gorn commander in *A Matter Of Honor* is the same unlikable reptile which Captain Kirk fought in the TV episode "Duel." Similarly, in *A Doomsday Like Any Other*, the players must defeat another planet-killer like the one defeated by the *Enterprise* in the episode "The Doomsday Weapon," while at the same time fending off a task force of meddling Romulan ships.

As is the case with all role-playing games, the key to enjoying *Star Trek: The Role Playing Game* is finding a good group

with which to play. Since characterization, plot, and the creation of a "sense of wonder" are integral to the Star Trek experience, you need imaginative, good-natured, and intelligent players to fully enjoy this game. You also need a good referee, someone to design and run the scenarios as well as maintain order and continuity from one gaming session to another. Before investing in the game, I suggest you find some other players; experience in Star Trek or other role-playing games is not required.

#### RECOMMENDATIONS

If you're looking for the best simulation of Star Trek, look into FASA's role-playing game. It has everything, from characterization to exploration to confrontation. If you buy the deluxe edition of *Star Trek: The RPG*, you will also receive FASA's starship combat game, which links the role-playing game to the slam-bang action of ship-to-ship combat in the Star Trek universe. The starship combats in this system are faster and bloodier than in *Star Fleet Battles* and each player on the bridge crew (science officer, navigator, engineer, etc.) has his or her own console to man, under the overall direction of the starship captain. With *Star Trek: The RPG*, you and a few other people can enter completely the exciting world of Star Trek.

If you don't have many friends interested in Star Trek gaming but you do own a home computer, buy *The Kobayashi Alternative*. It's a lot of fun, a real challenge, and best of all, it's the first of a series of Star Trek computer games. If you don't have other players or a computer, get *Star Trek III* or *Star Trek: The Adventure Game*, both of which can be played solitaire.

Finally, if you're primarily interested in starship combat, your best purchase is *Introduction to Star Fleet Battles*. After you have mastered this game, you can move on to *Star Fleet Battles*, which captures all the complexities of starship battles. It spans the gamut of possibilities from a duel between two starships to major fleet actions.

The best thing about the market of Star Trek games is that there is something to appeal to everyone's tastes. There are even Star Trek miniatures, lead models of the ships from the series and the movies as well as the new ships introduced in *Star Fleet Battles* and *Star Trek: The RPG*.

In other words, there's a large universe out there for you and your friends to explore. And there's more to Star Trek games than a double fizzbin. □

# MERCENARIES

# SPIES &

# PRIVATE EYES

a contemporary role-playing adventure game for solitaire or group play

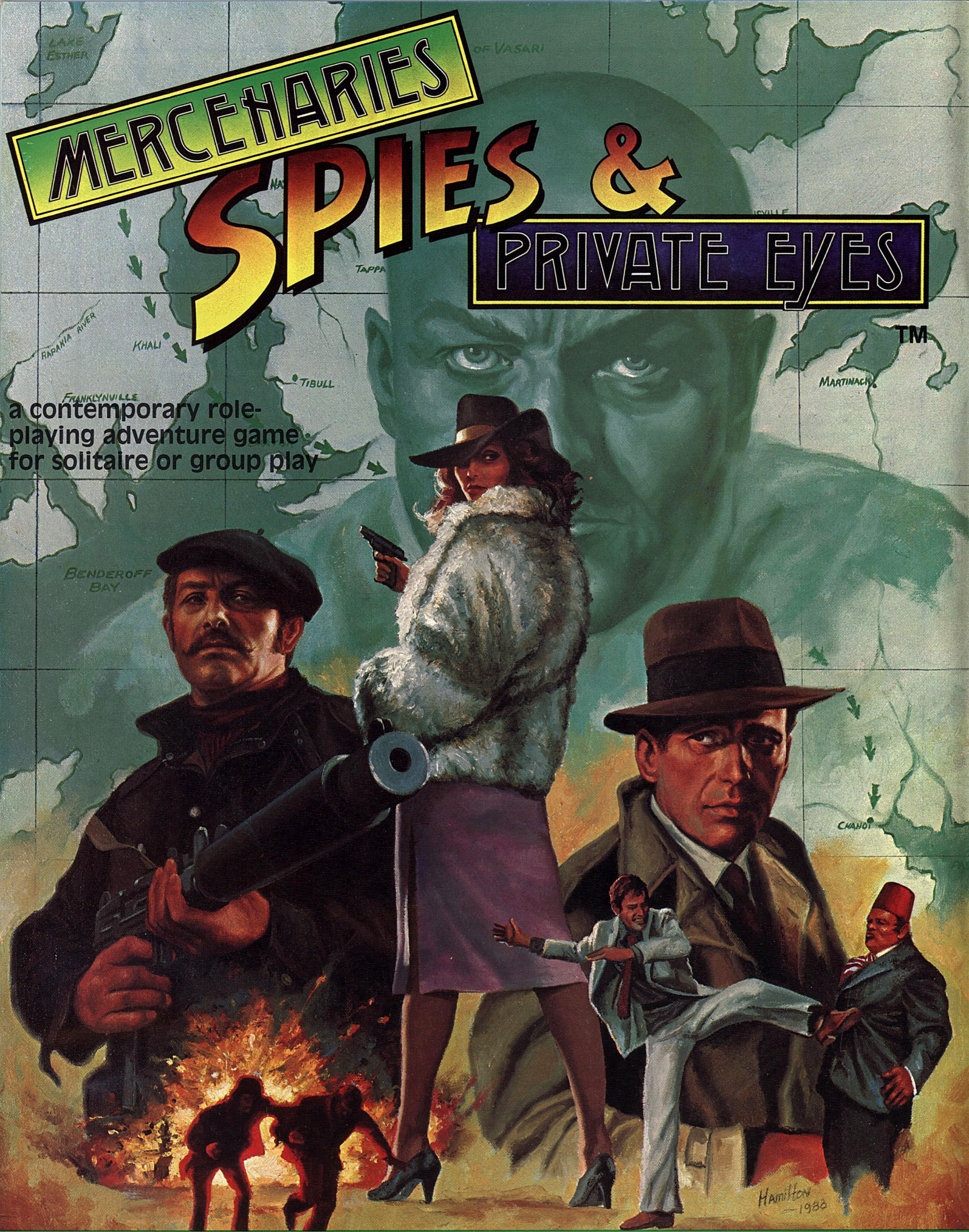

**NOW AVAILABLE FROM SLEUTH !**

USE ORDER FORM ON PAGE 39  
(SL-7000 BOXED \$20.00)



# Conventions

Conventions are the best places to meet new gamers. Organizers should send details of their convention at least six months prior to the event for announcement in this column.

*If you wish to see your convention listed in Different Worlds, send us the name of the event, dates, location, who to contact, the number of attendees expected, and the number of attendees you had last year. There is no charge for this service.*

## Neo-Vention VI June 5-7, 1987

At the Student Union, Kent State Univ, Kent OH. Gaming. Contact: NEO-GS, PO Box 412, Cuyahoga Fls OH 44222-0412.

## POLYCON

### June 19-21, 1987

At Cal Poly State Univ, San Luis Obispo CA. Gaming. Contact: POLYCON, c/o Saga, Box 168, Julian A. McPhee Univ Union, Cal Poly State Univ, San Luis Obispo CA 93407.

## ORIGINS '87

### July 2-5, 1987

At the Baltimore Convention Ctr and the Hyatt Regency Baltimore, Baltimore MD. Gaming. Contact: ORIGINS '87, PO Box 15405, Baltimore MD 21220.

## KINGCON III

### July 25, 1987

At the Lewis Building, City Park, Mt Vernon IL. Gaming. Contact (send SASE): KINGCON III, Rt 1 Box 202, Kell IL 62853.

## GEN CON 20

### August 20-23, 1987

At MECCA Auditorium & Convention Hall, Milwaukee WI. Gaming. Contact: GEN CON, PO Box 756, Lk Geneva WI 53147, (414) 248-8050.

## GATEWAY 1987

### September 4-7, 1987

At the Los Angeles Airport Hyatt Hotel, Los Angeles CA. Gaming. Contact: GATEWAY 1987, DTI, PO Box 8399, Long Bch CA 90808, (213) 420-3675.

## Pacificon '87

### September 4-7, 1987

At the Dunfey Hotel, San Mateo CA. Gaming. Contact: PACIFICON, PO Box 2625, Fremont CA 94536.

## WinGames VIII

### September 4-7, 1987

At the Univ Ctr, Univ of Manitoba, Winnipeg, Manitoba, Canada. Gaming. Contact: WinGames VIII, PO Box 80, Univ Ctr, Univ of Manitoba, Winnipeg, Manitoba, Canada R3T 2N2.

## DRAGON CON '87

### October 2-4, 1987

At the Pierremont Plaza Hotel, Atlanta GA. Science fiction/fantasy/gaming. Contact (send SASE): DRAGON CON '87, PO Box 148, Clarkston GA 30021, (800) 554-1162 or in GA (404) 441-3045.

## Rudicon 3

### October 16-18, 1987

At the Rochester Institute of Technology, Rochester NY.

Gaming. Contact: Steve Ritzau-Rudicon/RWAG, c/o Student Directorate, One Lomb Memorial Dr, Rochester NY 14623.

## Dragonmeet Baltimore November 27-29, 1987

At the Marriott Inner Harbor, Baltimore MD. Gaming. Contact: Timothy D. Olsen, Games Workshop, 231 Park Ave, Baltimore MD 21201, (301) 752-1493.

*For further information contact the convention organizers directly.*

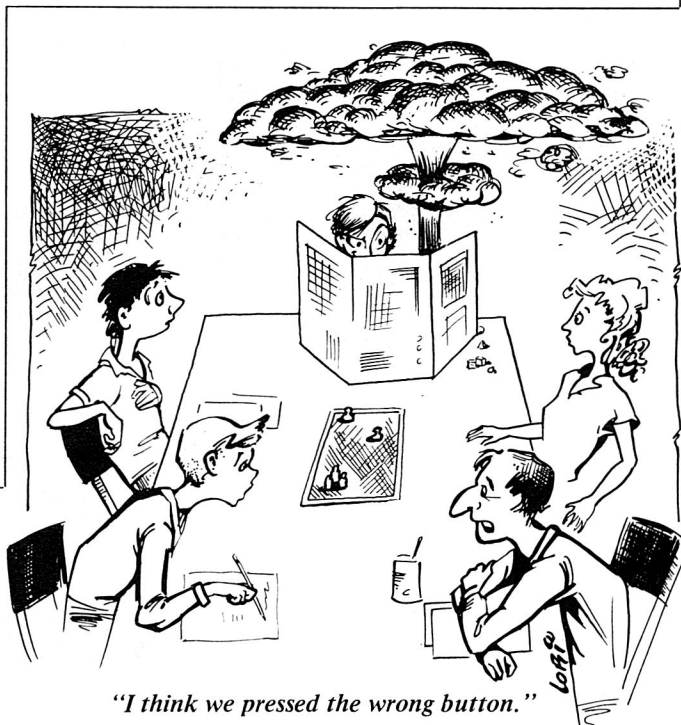

## White Dragon presents DragonAids™

DragonAids is a line of computer software designed to make the life of the GM easier.

### Macintosh

Familiar: Generates character sheets, treasures, magic items, scrolls, and much more, all in an integrated environment.

\$29.95 US

Modules: Five modules designed for use with AD&D, but could be easily converted to other formats.

\$14.95 US

Dungeons: A disk full of random dungeons to be used with any fantasy game.

\$14.95 US

### Apple & IBM

Dungeon Master's Companion: Similar to Familiar, but also allows drawing of dungeon maps. Apple version allows drawing of outdoor maps as well.

\$29.95 US

Send Check or M.O. to:

White Dragon,  
2412 Marlene Dr.,  
Victoria B.C. Canada V9B 4L5  
Allow 4 weeks for delivery

Coming soon for the Atari ST & CoCo 3  
AD&D is a trademark of TSR Hobbies.

5 FOR \$3.00      25 FOR \$10.00

## HYDROGEN BOMBS

MINIATURE NUCLEAR EXPLOSIONS

FOR USE WITH SUPREMACY,™  
NUCLEAR ARMAGEDDON,™  
"NUCLEAR" AXIS & ALLIES,™  
"NUCLEAR" RISK,™ & OTHER WAR GAMES

WRITE TO: NUCLEAR ARMAGEDDON  
Box 666  
Worcester, PA. 19390

# A TRAVELLER Police Character Generation System

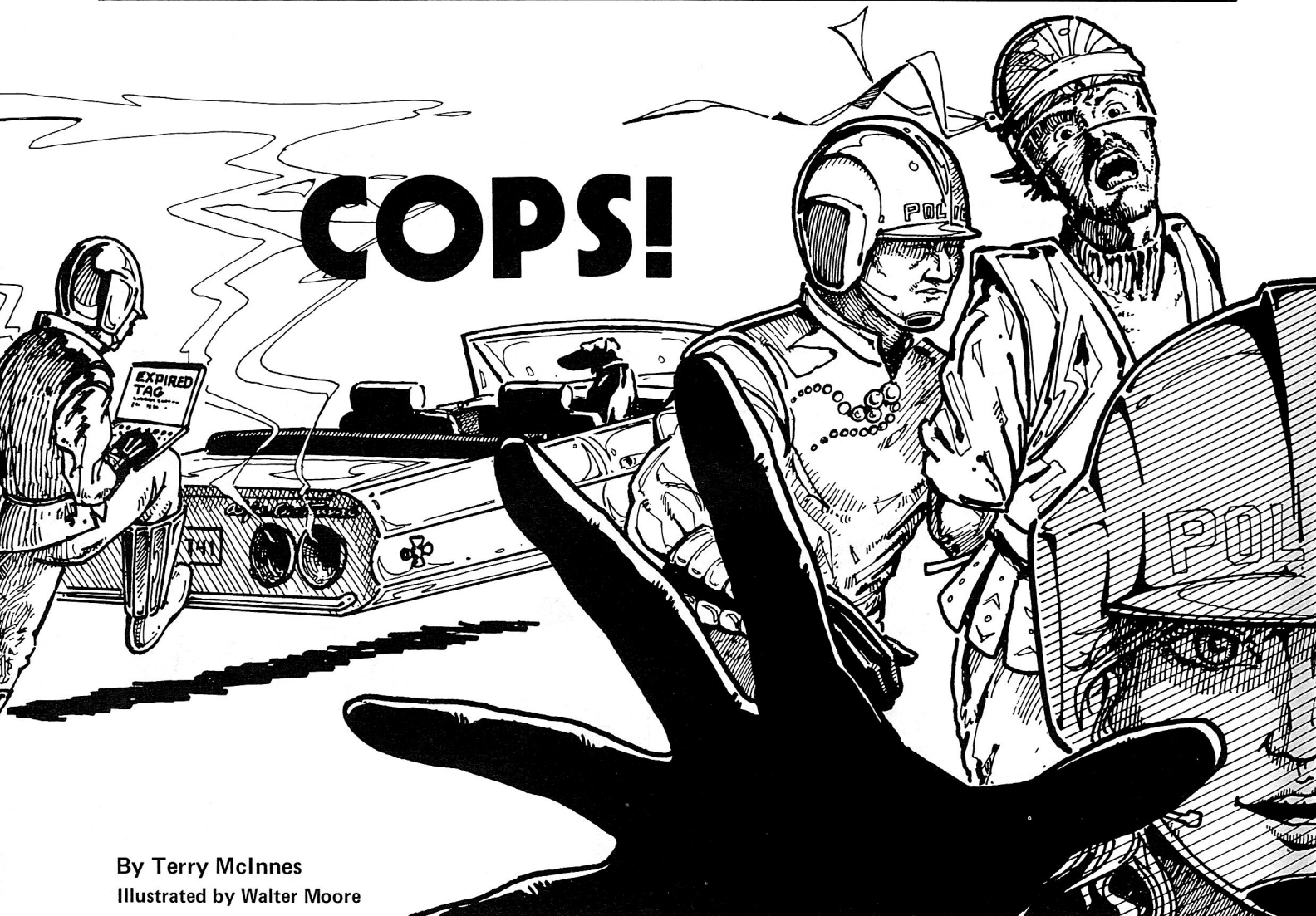

By Terry McInnes  
Illustrated by Walter Moore

HE WALKED down the hot, dusty street with one hand on the butt of his laser pistol. He paused a moment outside the corrugated aluminum saloon, then pushed open the doors and strode inside. The tired, dusty miners turned as he entered, a mixture of fear and respect on their faces.

One of the miners stared hard; first at his face, then at the badge on his shirt, finally at the holstered laser.

"Jensen," said the man with the badge. "Your time is up. Come quietly or draw."

He prayed Jensen would come quietly. He was the only deputy marshal within two-hundred kilometers—it would take nearly two hours for help to reach him by air raft.

Jensen turned slowly, a smirk on his face as his hand moved toward his holster. . . .

## THE POLICE

The police are one of the major forces citizens encounter in modern life.

They are around us every day, and they have the power of life and death over every citizen. At the beginning of this article, you have read just one small example of how police can interact with characters in the *Traveller* universe. On many worlds of the future they are even a greater factor in citizens' lives than they are today. (For a detailed treatment of police as found in the *Traveller* universe, see Loren Wiseman's article "Police Forces in *Traveller*" in issue 14 of *The Journal*.)

Although police are frequently encountered in *Traveller* adventures, they are seldom played as being more than one-dimensional. To give players a chance to encounter a police officer

with a background of service and experience; or to give players a chance to develop an experienced police character they could role-play in their own campaigns, here is a police character generation system designed to create a character with law enforcement skills that would be useful in many campaign situations.

Players can also use this system—which is similar to the Mercenary and High Guard systems with new skills added—so their characters can take on law-enforcement or investigation jobs during an adventure. This might include working as a private eye for hire, a frontier marshal on a backwater planet, or organizing and running a small police force for justice or profit.

## THE POLICE ACADEMY

The police officer begins his or her career at the police academy where he or she receives intensive physical, aca-

## THE POLICE DIVISIONS

There are five basic divisions in a police department.

**The Patrol Division:** The basic patrol and law enforcement division of a police department that is the primary contact with citizens and criminals in urban and suburban areas. Officers in this division patrol their assigned areas (beats) on foot or in vehicles. Their job is to be on the lookout for suspicious characters and criminal activities, to make arrests in crime situations, to conduct minor investigations, to aid citizens in distress, and to maintain civil order. Patrol division officers may also serve as plain-clothes undercover agents from time to time on stakeouts or to infiltrate criminal organizations.

**The Traffic Division:** The traffic division is responsible for patrolling the major roads, highways, and airways of the police department's area of jurisdiction and to apprehend violators of traffic laws. It also aids the victims of traffic accidents, and investigates accidents and vehicle thefts. In addition, division members are often called upon to assist other officers in the apprehension of criminals, and the suppression of civil disorder.

**The Constabulary:** The constabulary is the branch of a police force that specializes in patrol, law enforcement, and search and rescue duties in rural areas. In the case of a planet with a relatively low population level and one government, the constabulary would be part of the planetary police force. On a world where there are numerous police organizations, the constabulary would be a separate force. For game purposes, however, treat the constabulary as a branch of the planetary police. Separate constabulary forces would require a job candidate to have at least one year of police experience before they would accept a candidate into their organization, a fact that is reflected abstractly in this generation system.

**The Investigative Division:** The investigative division is the elite division on the force. Instead of performing mundane patrol duties, this division of plain-clothes officers spends its time inspecting the scenes of crimes for physical evidence, interrogating wit-

nesses, tracking down leads to criminals provided by a network of informants (also known as "snitches"), staking out the probable location of criminals, and identifying them and arresting them when sufficient evidence has been accumulated. Officers of the investigative division also cooperate closely with the prosecuting attorney's office and testify in court against criminal suspects.

**The Administrative Division:** The administrative division provides command and control over the police force and works closely with the local prosecuting attorney's office to prepare cases against criminals. Policies for personnel, training, and police methods are also set by this division, although the policies are actually executed by the field divisions. The officer must be at least a sergeant before he or she can be considered for duty in the administrative division. All police officers with the rank of captain or above are automatically transferred from field duties to the administrative division.

### POLICE SPECIFIC ASSIGNMENTS TABLE

	<i>Patrol</i>	<i>Traffic</i>	<i>Investigative</i>	<i>Constab</i>	<i>Admin</i>
2	Undercover	Undercover	Undercover	Rescue	Undercover
3	Undercover	Desk	Undercover	Rescue	SWAT
4	Desk	Desk	Undercover	Beat	Legal
5	Beat	Beat	Detective	Beat	Legal
6	Beat	Beat	Detective	Beat	Desk
7	Beat	Beat	Detective	Beat	Desk
8	Desk	Desk	Admin	Barracks	Desk
9	Beat	Desk	Admin	Barracks	Desk
10	Training	Training	Training	Training	Training
11	SWAT	SWAT	Undercover	SWAT	Training
12	Special	Special	Special	Special	Special

### SPECIAL ASSIGNMENTS TABLE

- 1 Riot Training
  - 2 SWAT Training
  - 3 Constabulary Training
  - 4 Air Patrol
  - 5 Legal Course
  - 6 Investigative Training
  - 7 Advanced Administrative Training
- DM +1 if intelligence 8+.

demic, and practical training in police skills. All police characters must be admitted to and graduate from the local police academy. In the *Traveller* universe, the police academy takes up the first year of the character's career. After graduation, he or she begins serving a short three-year term in the patrol division of the police force the character has joined.

The police candidate must pass the academy entrance exam with a roll of

7+ on 2D. Die roll modifiers include +1 if the candidate's strength is 9+, and +2 if the candidate's intelligence is 8+.

The new police cadet will succeed at the academy if he or she rolls 5+ on 2D with the following modifiers: +2 if intelligence is 8+; +1 if endurance is 9+. The cadet will graduate with honors if he or she rolls 9+ with a DM of +1 if intelligence is 8+. Honors graduates can choose to immediately enter

the investigative division of the police force.

Cadets earn the following skills at the police academy with a roll of 5+ for each on one die: 1D-3 additional strength points, Admin, Legal, Brawling, Shotgun, Tactics.

All cadets automatically earn Handgun-1 and Cudgel-1 at the academy.

### POLICE ASSIGNMENTS

Except for honors graduates from the

## SPECIAL ASSIGNMENTS

Police officers may be assigned to a variety of special assignments during their careers.

**Riot Training:** The character is assigned to learn how to control mobs and suppress civil disorder. He or she receives the following skills on a 1D roll of 5+ for each skill: +2 Shotgun, +2 Cudgel, Tactics, Gas Weapons, Brawling.

**SWAT Training:** The character is assigned to Special Weapons and Tactics School where he or she learns how to use the high-powered weapons and infantry tactics needed to deal with snipers and barricaded criminals. Skills received on a 1D roll of 5+ for each skill include Rifle, Shotgun, Gas Weapons, Auto Rifle, Tactics, Leader. Characters who have completed SWAT training also receive a +1 DM on their survival roll when serving on a SWAT assignment.

**Constabulary Training:** The character receives training in wilderness patrol and search and rescue tactics. The character may transfer to the constabulary after training is completed. Skills received on a 5+ 1D roll for each skill include Recon, Survival, Small Watercraft, Rifle, Medic, Commo, ATV.

**Air Patrol:** The character is assigned to flight training and then to police patrol aircraft. These aircraft would include light fixed-wing aircraft, helicopters, or grav vehicles depending on tech level. The character receives 1D-3 (at least one) Aircraft skill.

**Legal Training:** The character is sent to an intensive study course at law school and receives 1D-3 Legal skill.

**Investigative Training:** The character receives training as a criminal investiga-

tor. After this training is completed (whether or not skills are received via die rolls), he or she is eligible to transfer to the investigative division. This is the only way a character can enter the investigative division unless he or she is a police academy honors graduate. Skills awarded on a 1D roll of 5+ for each skill include Forensics, Liason, Legal, Streetwise, Interrogation, Computer.

**Advanced Administration:** This officer has been singled out as having high career potential and has been selected for advanced administration and leadership training. He or she is promoted one rank after completing training and is awarded the following skills on a 1D roll of 5+ for each skill: Admin, Tactics, Leader, Legal, Computer.

academy who enter the investigative division, all police officers are assigned to the patrol division after they complete their first year. Here, they will undergo additional training under senior officers and begin to serve in a variety of specific assignments. At the end of the second year of their first term, they may elect to transfer for one time only to the traffic division or

the constabulary division of their local police force. Officers may also transfer to the constabulary if they roll "Constabulary Training" on the Special Assignments Table at any time during their careers. Members of the investigative division are drawn either from honors graduates from the academy or from those who have undergone investigative training on special assignment.

## DUTY ASSIGNMENTS

Duty assignments are made and resolved annually during a four-year term. The specific assignment should be rolled on the Police Specific Assignments Table with 2D. If a special assignment is rolled, it should be determined with an additional 1D roll on the Special Assignments Table.

## BRANCH ASSIGNMENT RESOLUTION TABLES

<b>Patrol, Traffic:</b>	<b>Constabulary:</b>																																																												
<table style="width: 100%; border-collapse: collapse;"> <thead> <tr> <th></th> <th><i>Training</i></th> <th><i>Beat</i></th> <th><i>Undercover</i></th> <th><i>SWAT</i></th> <th><i>Desk</i></th> </tr> </thead> <tbody> <tr> <td>Survival</td> <td>auto</td> <td>3+</td> <td>6+</td> <td>5+</td> <td>auto</td> </tr> <tr> <td>Decoration</td> <td>none</td> <td>12+</td> <td>6+</td> <td>7+</td> <td>none</td> </tr> <tr> <td>Promotion</td> <td>none</td> <td>11+</td> <td>7+</td> <td>8+</td> <td>12+</td> </tr> <tr> <td>Skills</td> <td>7+</td> <td>9+</td> <td>5+</td> <td>7+</td> <td>none</td> </tr> </tbody> </table> <p style="margin-top: 5px;">DMs: +1 for survival if police skills at level 2 or greater; +1 on SWAT assignment if officer has had SWAT training. +1 for promotion if education 9+.</p>		<i>Training</i>	<i>Beat</i>	<i>Undercover</i>	<i>SWAT</i>	<i>Desk</i>	Survival	auto	3+	6+	5+	auto	Decoration	none	12+	6+	7+	none	Promotion	none	11+	7+	8+	12+	Skills	7+	9+	5+	7+	none	<table style="width: 100%; border-collapse: collapse;"> <thead> <tr> <th></th> <th><i>Training</i></th> <th><i>Beat</i></th> <th><i>Rescue</i></th> <th><i>SWAT</i></th> <th><i>Barracks</i></th> </tr> </thead> <tbody> <tr> <td>Survival</td> <td>auto</td> <td>4+</td> <td>6+</td> <td>5+</td> <td>auto</td> </tr> <tr> <td>Decoration</td> <td>none</td> <td>10+</td> <td>6+</td> <td>7+</td> <td>none</td> </tr> <tr> <td>Promotion</td> <td>none</td> <td>11+</td> <td>8+</td> <td>8+</td> <td>12+</td> </tr> <tr> <td>Skills</td> <td>6+</td> <td>8+</td> <td>5+</td> <td>7+</td> <td>none</td> </tr> </tbody> </table> <p style="margin-top: 5px;">DMs: +2 for survival if police skill level is 2 or greater. +1 for survival if endurance 10+. +1 for promotion if intelligence 8+.</p>		<i>Training</i>	<i>Beat</i>	<i>Rescue</i>	<i>SWAT</i>	<i>Barracks</i>	Survival	auto	4+	6+	5+	auto	Decoration	none	10+	6+	7+	none	Promotion	none	11+	8+	8+	12+	Skills	6+	8+	5+	7+	none
	<i>Training</i>	<i>Beat</i>	<i>Undercover</i>	<i>SWAT</i>	<i>Desk</i>																																																								
Survival	auto	3+	6+	5+	auto																																																								
Decoration	none	12+	6+	7+	none																																																								
Promotion	none	11+	7+	8+	12+																																																								
Skills	7+	9+	5+	7+	none																																																								
	<i>Training</i>	<i>Beat</i>	<i>Rescue</i>	<i>SWAT</i>	<i>Barracks</i>																																																								
Survival	auto	4+	6+	5+	auto																																																								
Decoration	none	10+	6+	7+	none																																																								
Promotion	none	11+	8+	8+	12+																																																								
Skills	6+	8+	5+	7+	none																																																								
<p style="margin-top: 10px;"><b>Investigative:</b></p> <table style="width: 100%; border-collapse: collapse;"> <thead> <tr> <th></th> <th><i>Training</i></th> <th><i>Detec</i></th> <th><i>Under</i></th> <th><i>Admin</i></th> </tr> </thead> <tbody> <tr> <td>Survival</td> <td>auto</td> <td>5+</td> <td>6+</td> <td>auto</td> </tr> <tr> <td>Decoration</td> <td>none</td> <td>9+</td> <td>6+</td> <td>none</td> </tr> <tr> <td>Promotion</td> <td>none</td> <td>10+</td> <td>7+</td> <td>11+</td> </tr> <tr> <td>Skills</td> <td>6+</td> <td>8+</td> <td>5+</td> <td>12+</td> </tr> </tbody> </table> <p style="margin-top: 5px;">DMs: +1 for survival if police skills at level -2 or greater. +1 for promotion if intelligence 8+.</p>		<i>Training</i>	<i>Detec</i>	<i>Under</i>	<i>Admin</i>	Survival	auto	5+	6+	auto	Decoration	none	9+	6+	none	Promotion	none	10+	7+	11+	Skills	6+	8+	5+	12+	<p style="margin-top: 10px;"><b>Administration:</b></p> <table style="width: 100%; border-collapse: collapse;"> <thead> <tr> <th></th> <th><i>Training</i></th> <th><i>Legal</i></th> <th><i>Desk</i></th> <th><i>Under</i></th> <th><i>SWAT</i></th> </tr> </thead> <tbody> <tr> <td>Survival</td> <td>auto</td> <td>auto</td> <td>auto</td> <td>6+</td> <td>5+</td> </tr> <tr> <td>Decoration</td> <td>none</td> <td>none</td> <td>none</td> <td>6+</td> <td>7+</td> </tr> <tr> <td>Promotion</td> <td>none</td> <td>12+</td> <td>12+</td> <td>10+</td> <td>8+</td> </tr> <tr> <td>Skills</td> <td>7+</td> <td>10+</td> <td>none</td> <td>5+</td> <td>7+</td> </tr> </tbody> </table> <p style="margin-top: 5px;">DMs: Promotion +1 if intelligence 10+.</p>		<i>Training</i>	<i>Legal</i>	<i>Desk</i>	<i>Under</i>	<i>SWAT</i>	Survival	auto	auto	auto	6+	5+	Decoration	none	none	none	6+	7+	Promotion	none	12+	12+	10+	8+	Skills	7+	10+	none	5+	7+					
	<i>Training</i>	<i>Detec</i>	<i>Under</i>	<i>Admin</i>																																																									
Survival	auto	5+	6+	auto																																																									
Decoration	none	9+	6+	none																																																									
Promotion	none	10+	7+	11+																																																									
Skills	6+	8+	5+	12+																																																									
	<i>Training</i>	<i>Legal</i>	<i>Desk</i>	<i>Under</i>	<i>SWAT</i>																																																								
Survival	auto	auto	auto	6+	5+																																																								
Decoration	none	none	none	6+	7+																																																								
Promotion	none	12+	12+	10+	8+																																																								
Skills	7+	10+	none	5+	7+																																																								

Other assignments should be resolved on the appropriate Branch Assignment Resolution Table with 2D rolls for Survival, Decorations, Promotions, and Skills that must meet or exceed the indicated number. Note and apply the DMs listed beneath each table.

If the listed number is rolled exactly on the survival throw, the character has been wounded, is automatically retired, and receives full monthly pay for the rest of his or her life. If the survival number is not met or exceeded, the character has been killed on duty. The nearest surviving family member receives a CR 100,000 life insurance death benefit.

## POLICE DIVISION SKILLS TABLE

	<i>Patrol</i>	<i>Traffic</i>	<i>Investigative</i>	<i>Constabulary</i>	<i>Admin*</i>
1	Liason	Gun Combat	Streetwise	Gun Combat	Legal
2	Interrogation	Vehicle	Surveillance	ATV	Legal
3	Streetwise	Vehicle	Interrogation	Survival	Admin
4	Surveillance	Streetwise	Legal	Recon	Admin
5	Vehicle	Liason	Forensics	Liason	Liason
6	Gun Combat	Air Raft	Computer	Vehicle	Commo
7	Computer	Computer	Computer	Computer	Computer

DM: +1 if world TL 9+.

Gun Combat: Choose Handgun, Shotgun, or SMG.

\*Character must have Sgt. or higher to enter Admin Division. All with rank of Lieutenant must throw 6+ to avoid posting to Admin Division. Captains and above automatically posted to Admin Division.

## POLICE SKILLS

Here is a set of new skills earned by police characters as well as some additional abilities given to them by skills previously described in other *Traveller* material. Other skills earned through the police character generation system are identical to those described in Book 1, Book 4, Book 5, and Supplement 4.

**Forensics:** This skill is the ability to find and examine physical evidence, and determine the identity of a suspect from this evidence. This skill would be used to locate and "lift" fingerprints, examine footprints, tire tracks, and other physical evidence at the crime scene, and to analyze tissue samples, hair samples, and other biological evidence at the scene and in the police crime lab. Forensics also includes the ability to examine weapons and spent ammunition from slug throwers to help determine the identity of a suspect. The referee should throw 10+ for the character to successfully determine the identity of a criminal from the evidence he or she has examined. DMs: +2 for each level of Forensics skill.

**Gas Weapons:** This skill reflects the knowledge and ability of the character to effectively use riot control gas weapons and to use protective gas masks. These weapons include tear and nausea gas grenades, gas projectile launchers, and gas projectors such as "pepper foggers." Throw 8+ for the character to effectively use a riot-control weapon to disperse a hostile mob or to incapacitate and capture a suspect. DMs: +1 for each Gas Weapon skill level. Characters using riot-control gases without experience may disable themselves on a throw of 7+.

**Handgun:** This includes skill in the use of a variety of handguns employed by

police officers as a positive DM on the "To Hit" die roll. Depending on the tech level of the officer's world, handgun skill could be applied to a revolver, automatic pistol, gauss pistol, or laser pistol. The latter two weapons are described in *Striker!*: Book 3. The gauss pistol is fully discussed in issue 13 of *The Journal*, page 43. Body pistol skill is not included as part of Handgun skill; rather, it is a separately acquired skill.

**Interrogation:** Similar to the skill described in Book 4, this skill enables the character to extract truthful information from suspects in custody and from referee-characters encountered during police investigations. Police characters should throw 8+ to receive a truthful answer from someone they are questioning. DMs: +2 for each level of Interrogation skill.

**Legal:** This skill demonstrates the character's education in law and the effectiveness of his or her testimony in court. This skill level can be added to that of the prosecuting attorney when the officer is testifying in a criminal case. The total attorney/officer Admin/Legal skill level is then used as a negative modifier in the acquittal throw as described in the article "High Justice" in issue 14 of *The Journal*. If the officer has a Legal skill level of 3+, this indicates he or she has passed the local bar association examination and is a qualified attorney. This gives the

character the option of quitting the police force and setting up his or her private criminal law practice.

**Streetwise:** This skill is identical to the skill described in Book 1 with one added feature: it enables a police character to determine if he or she is being given truthful and valuable information about a crime or suspect under investigation from his or her "snitch." Informants are often keys to the identity and/or the location of a criminal. A police officer will determine if information from a snitch is reliable on a roll of 8+ with a +1 DM for each level of Streetwise skill.

**Surveillance:** This skill demonstrates the character's ability to detect suspicious activity by observation, either on patrol or undercover "stakeout." Suspicious activity will be detected on a roll of 7+ with each Surveillance skill level applied as a positive die roll modification.

**Vehicle:** This skill applies to wheeled vehicles or grav vehicles depending on the tech level of the character's world. It also includes skill in operating two-wheeled cycles or grav cycles in addition to wheeled ground cars and air rafts. Wheeled and grav cycle design is described in the article "Civilian Striker! Vehicles" beginning on page 31 of issue 14 of *The Journal*, along with design procedures for ground cars.

If the decoration throw is met, the character has performed meritoriously, and receives a Chief's Meritorious Conduct Citation. If the decoration throw is exceeded by three, the character has been awarded the Commissioner's Medal for Gallantry. If the decoration roll is a 12, the character receives the Mayor's Medal for Bravery.

The character is promoted one rank if the promotion number is met or exceeded. The character may only be promoted one rank per term.

If the character meets or exceeds the skill roll, he or she then may roll once for a skill either on the Police Division Skills Table in their current division column, or on the Skills Table. All characters may roll on the Police Life column. Only officers serving on undercover, SWAT, or desk assignments may roll on those columns. The character must have the rank of Sergeant or higher to roll on the command column.

### RE-ENLISTMENT AND MUSTERING OUT

Characters must throw 5+ on 2D in order to re-enlist on the police force. Transfers between divisions may only occur after the completion of special training assignments, or upon promotion into the administrative division.

At the conclusion of the character's last term of service, he or she is eligible for mustering-out benefits. These should be determined by rolling on the Cash and Material Benefits Tables. One roll is allowed for each term of service. A DM of +1 is allowed if the character musters out with a rank of captain or higher. No more than three rolls are allowed on the Cash Benefits Table. Characters mustering out after five or more terms are eligible for retirement pay: see the Retirement Pay Table in Book 1, p. 21, for the annual amount. Aging is also conducted in accordance with Book 1. □

### SKILLS TABLE

	<i>Police Life</i>	<i>Undercover</i>	<i>SWAT</i>	<i>Desk</i>	<i>Command*</i>
1	Brawling	Brawling	Brawling	Commo	Leader
2	+1 Strength	Gambling	+1 Strength	Admin	Tactics
3	+1 Handgun	Carousing	+1 Endurance	Admin	Commo
4	+1 Shotgun	+1 SMG	+1 SMG	Computer	Admin
5	Liasion	+1 Body Pistol	+1 Rifle	Liasion	Legal
6	+1 Endurance	-1 Social	Tactics	-1 Strength	Computer
7					+1 Social

DM: Command +1 if Captain or higher.

\*Sergeant or higher.

### RANKS

	<i>Patrol/Traffic/Admin</i>	<i>Investigation</i>	<i>Constabulary</i>	<i>Monthly Pay</i>
	Patrol/Traffic Officer	Detective	Trooper	CR500
	Sr. Patrol/Traffic Off.	Inspector	Corporal	CR700
1	Sergeant	Detective Sgt.	Sergeant	CR1000
2	Lieutenant	Detective Lt.	Lieutenant	CR1200
3	Captain	—	Captain	CR1500
4	Deputy Chief	—	Deputy Marshal	CR2000
5	Chief	—	Marshal	CR3000
6	Commissioner	—	Interior Minister	CR4000

### CASH BENEFITS TABLE

1	CR2000
2	CR5000
3	CR5000
4	CR10000
5	CR20000
6	CR20000
7	CR50000

DM: +1 if Rank 5 or 6 or if the character has gambling skill.

NOTE: No more than three rolls may be made on this table.

### MATERIAL BENEFITS TABLE

1	Low Passage
2	+1 Intelligence
3	+1 Education
4	Handgun*
5	Body Pistol
6	High Passage
7	+1 Social

DM: +1 if Rank 5 or 6.

\*Can be auto pistol, revolver, gauss pistol, or laser pistol, depending on the tech level of the character's home world. The handgun benefit must be declared immediately; additional handgun benefits may be an additional handgun type or an increase in skill level of a previously chosen weapon.

### Designing a Game? Want to get it published? Game Designers' Guild

The GDG isn't a union, broker, or an agent - but it can help you avoid problems in getting published. Full or Associate Memberships available. Write for more information to: Guild President, Greg Costikyan, c/o West End Games, 251 W. 30th St., NY, NY 1001.

### WHAT PRICE GLORY? The Game Collector's Guild knows...

Classics, turkies, rarities, hard-to-finds, out-of-prints; *we know what they're worth!*

For more information write:  
The Game Collector's Guild  
P.O. Box 5239  
Laurel, MD 20707

### Origins '87

July 2nd-5th, 1987 at the Baltimore Convention Center and Hyatt Regency Inner Harbor.

For more information write:

**Atlanticon**  
Dept. C.A.  
P.O. Box 15405  
Baltimore, MD 21220

or call

(301) 298-3135

Sponsored by **GAMA**, the Game Manufacturer's Association.

# ANYWHEN

Worlds of adventure and excitement in the role-playing system of the future.

Even before the night had fallen, they came back; hordes of mutated creatures, demons and ghosts, armed with rifles and grenades by their master, the insane sorcerer Black Wolf. Teinquerion watched his friend ready another arrow and take aim at the closest mutant. For nearly two days now, they had fought back attack after attack on this lonely crag of rock, and the elf still did not show any signs of fatigue. Teinquerion, human by birth and fighter by trade, thought back on all the fiends he had vanquished in his life. He remembered the giants that had raided his homeland, smashing entire houses with their bare hands, the wars between the Free States, the soldiers who fought with steel and the merchants who fought with gold, the witch-king he had defeated in single combat, and so many others. He had fought all his life, against swords and against spells . . . and now against machines. An elf screamed to his left, flung off the crag by machine gun fire, dead before he hit the ground. Hideous creatures threw themselves on him, swinging blood-encrusted axes and maces; Teinquerion blocked the first one's blow, and riposted with his longsword, slashing deep in the mutated flesh. The creature howled, falling on his comrades who were still scaling up the crag. As the elves fought on and the mutants fell back, Teinquerion began to hope that he might live to see another day, in the grim world of **Fireland** . . .

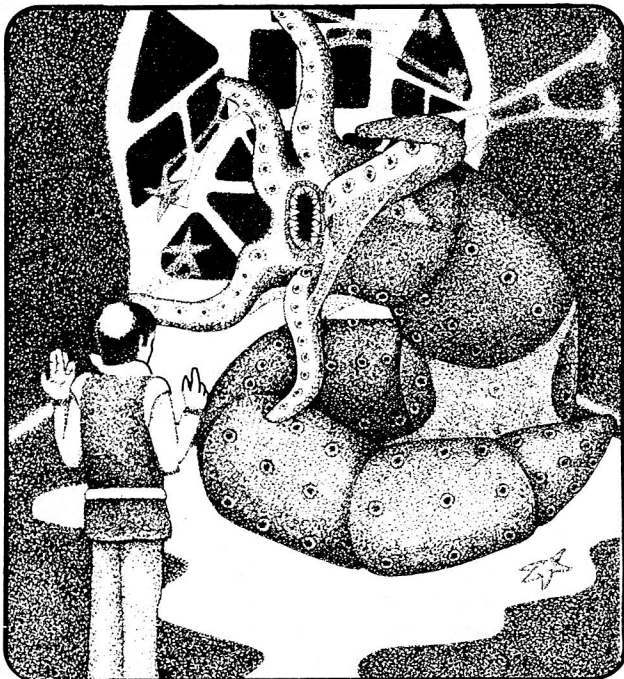

The gigantic worm-shaped creature drunkenly slithered forward, dripping toxic slime as it reared its tentacled head towards Father Vicente. A deep throbbing sound came from it, followed by the translator's metallic voice: "Explain to me again exactly what it is you mean by immaculate conception, priest-human." Father Vicente stepped back, trying to avoid the noxious ammonia vapours the thing was releasing; he had been given poor assignments by the New Vatican cardinals, but never quite so bad. Nevertheless, alliance with these creatures would give the Holy Empire enough power to defeat the imperial cities of earth and free thousands of star systems. He somehow had to convince this alien monster that Pope Catherine represents God in the universe, and siding with her would mean glory not only in this world but in heaven. Father Vicente struggled to find the right words. "It is something like that, the Holy Spirit is . . ." Father Vicente never finished his sentence, as the salvo of nuclear missiles hit his ship vaporizing him and the Outworlder ambassador. Thousands of miles away, aboard a strike cruiser of the imperial city of Tucson, an officer grinned as the censors reported a direct hit. There would be no negotiations this time; New Vatican would have to fight alone against the might of **IMPERIAL EARTH**...

**K** ANYWHEN... Dare to adventure in thousands of perilous worlds across time and space. Whether you prefer science fiction, fantasy, horror, or any other environment, **ANYWHEN** will give you the worlds if you have the imagination and courage. **Fireland** and **IMPERIAL EARTH**, the first two game-worlds of the **ANYWHEN** universal role-playing system, are available at your local hobby or game shop. For additional information write to . . .

K Society, Games Division, P.O. Box 702554, Tulsa, OK 74170, or call (918) 663-4854.



# Adventuring in the World of **THE MORROW PROJECT**

By Joseph Benedetto, Jr.  
Illustrated by H.N. Voss

THE YEAR was 1962. Seeing that a Third World War would someday engulf the Earth in nuclear war, millionaire-industrialist Bruce Morrow created the Council of Tomorrow, a group of the country's best thinkers and industrialists. Together they created a plan that would ensure the survival of civilization: The Morrow Project.

In the years that followed 1962, the Project grew and developed and refined itself. The idea behind the Project was simple: take people, train them to do their jobs, then arm and equip them; take them to specially-constructed bunkers (called Boltholes) scattered around the country, and freeze them in suspended-animation until after the war. Provide major facilities for them—power stations, re-supply points, hospitals, etc.—and give them the materials needed for the reconstruction.

A central HQ (Prime Base) would wait out the conflict and then, when things were judged safe (perhaps months or even two or three years after the bombs fell), Prime Base would send coded radio signals to the Boltholes to awaken the teams. RECON teams would come out and scout out the terrain in their area, and then report the situation(s) back to Prime Base. Prime Base could then raise Science teams or specialty groups or MARS units (Mobile Assault, Res-

cue, and Strike teams . . . the strong arm of the Project) to handle the local problems that the Recon teams could not handle. All of these teams would eventually link up, and, acting as the eyes and ears of Prime Base, help the survivors to rebuild.

At least that's the way it worked out on paper. . . .

## THE BEGINNING OF THE END

World War III broke out on Thursday, November 18, 1989, when the United States launched a first strike attack against the Soviet Union. The strike was launched in response to an apparent attack from the Soviets; it was later discovered that the attack was only a programmed simulation accidentally fed into the NORAD computers. However, because of this first strike, the US was able to knock out a large portion of the Soviet arsenal. Of course, retaliation came, and the United States was badly devastated. Every major city was a target, and

most were plastered by nuclear blasts; others were poisoned by bio-war agents. The destruction was incredible.

The outbreak of another world war released years of hatred around the globe and most of the planet was swept up into the One-Day-War as the smaller countries began attacking each other. Within hours, the major nations had ceased to exist as cohesive entities; within days, as the bodies of the dead and dying piled up, most forms of technology destroyed, and the cold of late fall/early winter setting in (in the Northern Hemisphere, anyway), "civilization" collapsed. Without his technological tools, scientific man was left defenseless: no electricity to run his many gadgets, and no knowledge of how to return to a simpler way of life; those who survived the bombings were to die from their lack of knowledge in survival-related skills. For some, it could be how to plant and farm; for others, something as simple as opening a can without a can opener. By the spring of 1990, some 95% of the world's population was dead of various causes. Those few who remained were reduced to a pitiful level, scraping out a meager existence off of the poisoned land. They became quick, cunning,



## R-001 LIBERATION AT RIVERTON

By H.N. Voss

The first of the Timeline modules introduces a new, comprehensive combat damage system for armored vehicles—the players' vehicle in particular! This combat system, using hit locations, penetration chances, and percentage of internal damage, allows for a much more realistic system than the earlier "You're hit: two dead, one injured, car stops" system found in the rulebook. The new system lists various items in the vehicle in the way of the blast, as well as chances for crew injuries ("The blast deafens you momentarily, and the car rocks on its shock absorbers. Bill is picking the battered remains of the radio out of his lap, and when Dave shifts gears, all you hear is a sick, crunching sound.")

*Riverton* deals with a Recon team that awakes into chaos, without orders or contact from Prime Base, apparently cut-off and on their own, with the locals in trouble from the "imps." The module contains detailed interior views of the players' vehicle, a Cadillac-Gage Commando V-150 Armored Car with a 20mm, turret-mounted autocannon; the aforementioned combat system, with charts for the V-150 20mm and the M60 Main Battle Tank; information on new weapons not covered in the Game Book, a floorplan of a typical Bolthole, and background details on the Project and the players' gear. The various plans and charts are a very good aid to playing the game; this is a very good module for beginners, and is extremely high in "shoot-'em-up" potential.

## R-002 DAMOCLES

By H.N. Voss

The second module is rated "for the experienced to expert player," mainly because, although it has a high potential for being a shoot-'em-up, it is actually a "let's think this one through" game. Set in Michigan's Upper Peninsula, this module sets a Recon team into a frigid, harsh land where the locals tell strange tales and unusual things are happening. The players must investigate, in a situation that calls more for diplomacy and talk rather than heroics and gunplay.

The module contains an extensive section on computers, blueprints, combat tables, and illustrations of the New Commando Scout Armored Car and the XR311 "jeep," plus the Morrow Project Cold Weather Kit, and extensive background information on the situation. A very fun module, it is more suited for experienced players, and those

TIMELINE HAS so far produced only seven modules for their *Morrow Project* game, but these all tend to be well done, and each lends itself well to campaign play. The modules are also easily linked together for a running campaign of adventures, even though each one starts out assuming the players to be a local team just waking up to the new world of the 22nd century.

# Morrow Project MODULES

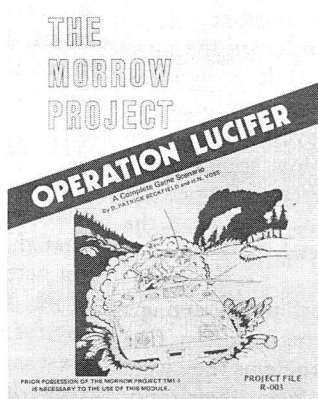

who realize that it is often better to talk than to shoot. It is also designed to be linked with modules R-003 and/or R-004 if desired.

## R-003 OPERATION LUCIFER

By D. Patrick Backfield  
and H.N. Voss

Setting yet another Recon team into action, this module takes place in Wisconsin, putting the players into a race to find an unexploded nuclear bomb. Strange radio messages from an unknown unit order the team into action, but no one appears to know just where exactly the bomb is; the team has over 20,000 square miles to cover! To make matters worse, there is the threat of a Krell invasion, so the players must scramble to find, recover, and disarm the bomb before the bloodthirsty Krell can get it. Strange dangers and wonders, from unusual places and creatures to the return of Zorro plague the players' footsteps.

This module contains charts and interior views for the V-150 APC (armored personnel carrier), more new weapons, the Morrow Project Contact Pack, and a listing of the typical items to be found in a standard Recon team cache. Full of excellent details, this is a good module for beginners although it can become a wild-goose chase if the players aren't kept on course. Definitely not a shoot-'em up (except perhaps at the end).

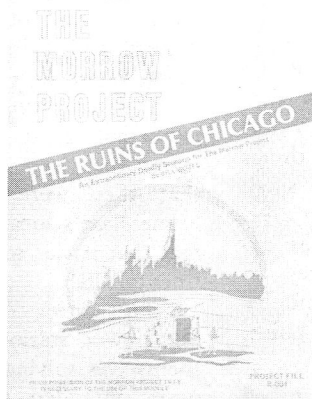

## R-004 RUINS OF CHICAGO

By Bill Worzel

A team awakes and is ordered into the ruins of the city of Chicago by an unknown radio unit operating on scrambled MP frequencies; the team must Recon a local university and survey the possibility of resurrecting a computer center and setting up an advance base. On the way, the players must deal with the local inhabitants, strange creatures, the "City Machine," and the big surprise, "Fort Morrow"! Players have to be fast on their feet if they hope to accomplish this mission!

Contains interiors and combat charts for the Commando Ranger Armored Car, plus new weapons and gear. It is extremely dangerous, though, and fully merits the warning on its cover: "An Extraordinarily Deadly Scenario for the Morrow Project." Definitely not for beginners!

## R-005 THE STARNAMAN INCIDENT

By C. Starnaman and  
H.N. Voss

Set in Kentucky, the players (a Recon team assigned to a MARS group) awake into a place where they are feared and hated, for no apparent good reason; twisted legends and confusing evidence only worsen the situation. Most important of all, this lone team has to locate and secure Delta Base, a nearby MP facility.

Contains the usual new weapons and gear, plus information and charts on two new MP vehicles: the V-150 81mm mortar carrier, and the V-150 ARV (armored recovery vehicle). Also, there are detailed maps of Delta Base, a MP re-supply facility full of goodies needed by the Project to rebuild civilization. The module is good for beginners, and is generic enough to be set in almost any campaign with little difficulty. A "let's think" module rather than a shoot-'em up.

## R-006 LONESTAR

By H.N. Voss

Set in Texas, a special group, Combined Team 13 (half MARS/half Science) has been given a mission: recover the Johnson Space Center. Not an easy task when an army of brutal savages is sweeping in from the south, maiming everyone in sight. With the earmarks of an out-and-out war, this is not a simple, quiet scenario!

It introduces three all-new MP vehicles of the ACV class (air-cushioned vehicles, or hovercraft, if you prefer): the Albatross Scout, the Flying Dutchman MARS vehicle, and the Quequod Science vehicle. New weapons and data are included as usual. Good for beginners and experts alike, this is most definitely a shoot-'em up.

## R-007 DESERT SEARCH

By Joseph Benedetto, Jr.  
and H.N. Voss

A Recon team assigned to Group N (a collection of MARS, Recon, and Science/Support teams) is in the middle of the Southern Nevada Desert with the mission to guard a MP power station. Ensuing events soon leave the players alone, without aid, and in trouble as they fight a ruthless enemy while trying to find the missing power station before it can fall into unfriendly hands.

*Desert Search* introduces two more MP vehicles: the V-150 TOW carrier the FAV (fast attack vehicle, a dune buggy-like jeep), but, sadly, does not include any damage tables for these new vehicles! However, information is included on new MP weapons and gear, the MP Desert Terrain Kit, and a complete layout and description of the MP power station. Good for both beginners and expert players, it lends itself to be either a shoot-'em up, or a let's think module. (This module is also the lead-in for the upcoming *Prime Base* module.)

## R-008 PRIME BASE

This module, not yet released, will deal with the missing Prime Base facility.

selfish, and often cruel; that was how they managed to survive.

The world they inherited was a shambles. The dread “nuclear winter” did not materialize, but its ghost was felt by way of shorter summers and longer winters (every season is now colder than its pre-war counterpart). The land lay in ruins: radioactive fallout, bioweapons, the blasted ruins of the cities, crazed survivors at every turn—those who were left alive and sane had little with which to work.

And the Project? Well, of course things didn’t work out just right. True, the vast majority of the Project had survived the bombings intact; the only point was, they were still asleep. Prime Base was the only MP facility that stayed awake through the Third World War. It survived, and, after things quieted down, sent out a few small teams to scout the surrounding area. Things were as good as could be expected under the circumstances, so Prime Base set up a small community and started to rebuild. At that point, everything went wrong.

A madman named Krell destroyed the colony with a nuclear device, and then used biological sabotage to destroy Prime Base. The destruction of the key in the MP plan was so swift that there was not enough time to send off radio signals to any of the buried teams or to the back-up Prime Base (a facility similar to Prime Base in all respects except for the fact that the entire complement of personnel were in cold-sleep). Thus, Prime Base was knocked out of action before the major portion of the plan could be implemented.

The result was that the frozen teams never came out of cold-sleep. The radio signals were never sent; the Bolt-hole computers waited patiently, keeping their sleeping charges alive and well. Years went by; still the teams slept on. Occasionally, someone would stumble onto a team’s cache of supplies, or even across one of the Bolt-holes, but, by and large, the members of the Project slept on undisturbed and unaware of the passing of time.

In 2139, a damaged computer began to function again, and started sending the wake-up signal to various teams scattered around the US. These teams, awakening and gearing themselves up for the “brave new world” found that although someone had sent the coded wake-up signal, there was no one to be contacted—Prime Base did not respond to radio calls, nor did any of the other MP facilities.

The players soon find out that they are alone in a world that has changed far more than could be possible in just a few months or even a few years after a nuclear war. In effect, these people, who remember their TV and frozen pizzas as if it were yesterday, have become unwilling time-travelers thrown 150 years into their own future, with no way back.

Equipped with the pack, gear, and weapons on their backs, and (usually) at least one fusion-powered armored vehicle to carry them, they are out on their own, trying to help the locals, trying to find other members of the Project, and trying to locate the now-silent Prime Base. (As it is in every good organization, security was all-important—most players belong to teams that were so low security-wise that they were never informed of Prime Base’s location, other than the fact that it was somewhere in the continental US.)

From fighting “imps” to protecting a MP power station, teams often find themselves solving problems they were never intended to face; their only standing orders are: Help the people in any way possible, link up with the rest of the Project as soon as possible. This means the players must be imaginative, creative, diplomatic, and must work together. However, unlike other post-holocaust role-playing games, players in *The Morrow Project* usually have enough gear and goodies to swamp a landing barge; this serves, though, to create problems of another nature: given so much in the way of guns, ammunition, and technological playthings, players end up worrying more about bandit raids on their camp during the night (“Did ya see all them guns and stuff them strangers had, Ace?”) than they do about running out of ammunition and supplies (“Here they come again, Linda! How much ammo do we have left?” “Oh, about three or four cases. . .”). Of course, recovering an entire supply cache can mean problems too (“Six weapons, a plow, seed corn, twenty cases of ammo and grenades, and twelve boxes of gear. Where are we supposed to put all this stuff?!?”). In the end, it still means the same thing: does Might make Right? (or more simply, Do I shoot and hope for the best, or should I try talking this out?).

But there are always problems of one sort or another. The *Morrow Project* world is certainly not the same world found in *Rogue 417*, *Invasion US*, *Gamma World*, *Aftermath!*, *Twilight*:

*2000*, or *Price Of Freedom*; it has its own unique trials and dangers for the unwary. The unbelievably radioactive “blue undead,” gigantic bears, a world populated by peoples believing strange legends passed down and twisted by more than a century of retelling . . . all combine to form a world that is dangerous, intriguing, and fascinating. Given the right circumstances, the team (and the players themselves) can decide how to help the people, and how to reconstruct the civilization that died out in 1989. This means that the players could become the new law-givers, the new Washingtons and Lincolns. It also means that they could become the new Napoleons and Hitlers. . . .

## THE PEOPLE

Survivors began to band together wherever it was possible; they found that the places they could go to, were no better than where they had started from. Many simply stayed put, fighting for survival in a place that they at least recognized.

The land lay empty. Without man’s intervention, the Great Forest, a mass of trees that once stretched from the Atlantic coastline, far out into the Midwest, was returning. Secondary succession of plant growth reclaimed the land, and man’s monuments to himself were lost to nature. Animals returned; cities, even those untouched by the war, lay uninhabited, without water or power or people, until age took its toll and they fell into ruin. The land was left empty and abandoned except for a few small pockets where people still lived.

Morals and ideals changed from those held before the war: a famous country singer might be allowed to starve so that an unknown farmer could survive and practice his trade. A little-known writer who had researched survival skills and knew how to build log cabins would be protected so that he could pass on his knowledge; a writer of famous porn books would be left to the wolves. And so it was: those who were valuable were kept alive by others; those who couldn’t (or would not) contribute to the group survival were left to fend for themselves. It was a cruel world; it had to be.

Technology was lost in the shuffle to survive. What good is it to know how to run a computer or fix a TV set if you haven’t any food to eat? So, technology fell by the wayside and died out, save in a few small enclaves where it was kept alive, jealously guarded,

and preserved by the few who could use it. By and large, however, the ways of the past were lost; they became nothing more than legends and odd memories. The ways of the "Old Ones" were lost, forgotten, or attributed to "magic." (Although few people "today" attribute the old legends to actual magical powers—anyone trying the "See my great magical powers" routine usually gets laughed at.)

## THE WORLD OF 2139

This is 2139, in the 22nd century, into which the MP teams are thrust. Technology is still very low: most people use muskets and early-design rifles (if they even have any firearms at all!), while others have little more than clubs and bows. Few (if any) places have a tech level worth mentioning; what few modern guns remain are old, worn, and very low on usable ammunition.

The immense amount of radiation released during the war, often combined with strange and mutated bio-war agents, created strange creatures that now inhabit the earth. However, these creatures are much less deadly and far less strange than most science-fiction writers would have had us believing were coming; most things that mutated were strange and often hideous, that's true, but were also almost always sterile. There were no giant landsharks, no dog-people, no huge birds shooting radiation from their eyes.

But there were other creatures that did mutate and survive: creatures whose mutations helped (or at least did not hinder) survival. Thus, the average man of the 22nd century thinks it common to see gigantic skunks, two-story-tall grizzly bears, a moose that stands three-feet tall when fully grown, and a black fly whose size is measured in feet, not millimeters. The cities spawned their own radiation-induced monsters: strange little humanoid things that live in sewers and tunnels, coming out at night to kill and to eat (people, of course); people who were affected by a mutated virus and are now able to only digest fresh blood—modern vampires; the hideous "blue undead," a creature, apparently once human, that is now nothing more than a man-shaped mass of glowing blue matter that is incredibly radioactive, and nearly indestructible; monsters that can kill a person dead real quick (and, just as it is in real life, there is no "resur-

rection spell" to bring a character back to life).

The remaining ruins of the 20th century have become a home for men and animals alike; places of curiosity, havens of shelter, spots of local taboos, or goldmines waiting to be searched and rummaged-through for tradeable goods. With all this, it is little wonder that so little remains from before the time of the war. The 21st century, with its emphasis on survival, left little time to salvage much from the ruins. The 22nd century, with its relative stability, had found little to rebuild.

The survivors have become set along various paths, usually at low tech levels reminiscent of the America of the late 1700s and early 1800s. They have recovered what they can, and through trial and error, and by rediscovery, are returning to higher tech levels. Because of what the war did, much of the population is uncivilized, or just barely so. Those who are civilized need help just to survive, let alone prosper through these dark years. The Project is often aptly suited to some of the needs of the new population, but just as often is ill-equipped to handle the situation: what good are a hundred geiger counters to a community that needs rifles or seed corn?

The United States is not alone in these problems, although no one alive today has any real knowledge of what is going on in other parts of the globe. The Morrow Project had more than enough trouble preparing to survive a nuclear holocaust in the United States; yet, they planned to help the other countries of the world as well. A plan was devised, a plan to help the other nations of the planet rebuild to a time of peace and safety: The Atlantis Project. For its part, however, the Morrow Project deals with the United States; later modules will deal with other locales on the globe.

## THE WORLD AS IT IS TODAY

The world is in as sad a shape as it has ever been. The Great Forest covers much of the continent, save in places where trees do not naturally grow, or man has cleared the land. The forest has swallowed up and covered entire cities, erasing much of the lost civilization; it is a dark and foreboding place of moving shadows and lonely narrow wagon paths, and one never knows what may life around the next bend in the road ("Did you hear that?").

To the far north, a new Ice Age has begun, expanding the Polar Ice caps

and lowering sea level. All seasons have noticeably cooler; short summers and long winters are the norm now. Mutant wolves—throwbacks to the dire wolves of the last Ice Age—are stalking the land; the cold winters have driven the animals as far south as Kentucky, where these smart, semi-intelligent animals are threatening the local population.

New wars are being fought: Krell, who survived the 20th century by going into cold sleep and having himself revived every few years to lead his armies, is again awake and leading an army of killers on a great push along the Mississippi in an attempt to capture and kill as many MP personnel as he can.

In the south, the Republic of Texas, probably the largest and most civilized spot left in North America, is under attack from savages from the South, the descendants of survivalists who took refuge in southern Texas prior to the war. These people are moving northward, bringing terror and destruction with them.

In the east, the Rich Five—20th-century industrialists who had themselves and parts of their empires frozen before the war, have come out of cold-sleep and are constructing a slave-holding culture along the eastern seaboard, from Vermont to Georgia and as far west as Kentucky. They are even building an honest-to-goodness city in the Kentucky Highlands. What threat these people pose to the Project has yet to be determined.

In the west, a new civilization is taking root in the region around Lake Tahoe in Nevada. Strange groups populate the few inhabited towns, and Amerinds control the desert regions. Morrow Project facilities in Lower Nevada have already been threatened by these people. The barren wilderness is once again an uninhabited land.

Around the country, various groups—from flying 'balloon cities' to technology-destroying Razers to witches and warlocks to 20th-century Green Berets and Canadian Commandos, who were put into cold-sleep to find out what the "Morrow Project" was—all move across the land, all live and work in this world, and all pose potential threats to the Project.

Enter the Project. Scattered few and far between, various teams that are otherwise cut-off have tried to help, to survive, to make contact with each other, and to pool their resources to help improve the lot of their fellow man. It is an uphill battle all the way. □

# HORROR & THE SUPERNATURAL

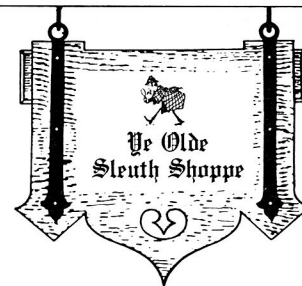

Use order form on page 39.

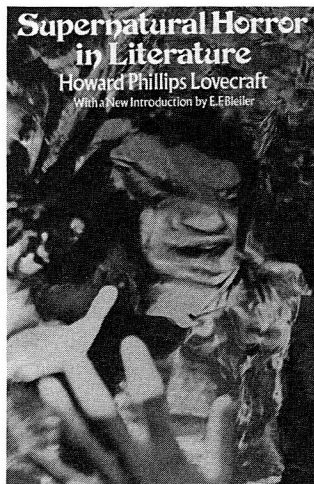

**Supernatural Horror in Literature** by H.P. Lovecraft. The greatest American supernaturalist of this century brilliantly surveys the genre into the 1920's with discussions and evaluations of scores of books and such authors as Poe, M.R. James, Bierce, Lord Dunsany, and Arthur Machen. By charting so completely the background of his own concepts of horror and literary techniques, Lovecraft throws light on his own fiction as well as on the horror-literature which has followed in his influential wake. For this reason this book will be especially intriguing to those who have read and enjoyed Lovecraft's fiction as an isolated phenomenon. Those and other readers, searching for a guide through the inadequately marked regions of literary horror, need search no longer. (DO-20105-8 softcover 111pp \$2.95)

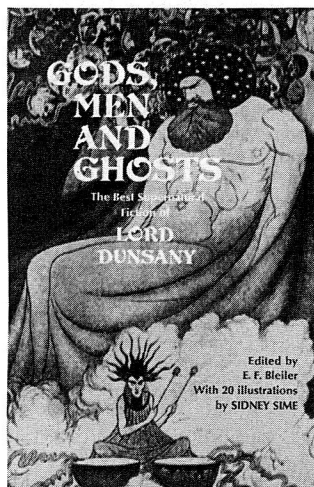

**Gods, Men and Ghosts** by Lord Dunsany. Among the great masters of supernatural and science fiction of the 20th century is the Irish writer Edward J.M.D. Plunkett, 18th Baron

Dunsany. An outstanding dramatist whose supernatural plays anticipated the theatre of the absurd, a virtuoso writer of short stories and essays, he was one of the most original talents in English literature. In addition to being one of the great formative influences in the development of the supernatural genre, he was also the author of many of the best fantastic tales in the language. Here are the finest of Lord Dunsany's works gathered from sources long out of print—"Three Sailors' Gambit," the remarkable trilogy about Nuth and the Gnoles, "The Gods Of Pagana," and other masterpieces. (DO-22808-8 softcover 260pp illustrated \$4.95)

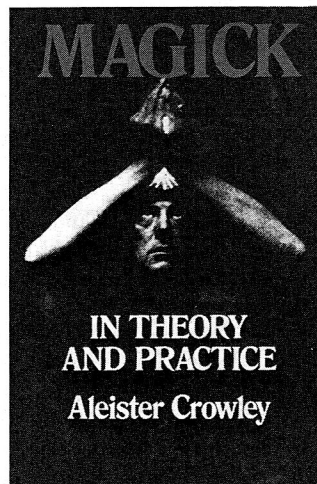

**Magick: In Theory and Practice** by Aleister Crowley. This is the foremost book on ceremonial magic written in the 20th century, the summation of the thought and life practice of the century's most famous necromancer and one of its most infamous figures. It was prepared by Aleister Crowley (1875-1947) specially for neophytes. Written at the height of his involvement, it is probably Crowley's best book. The magical theory of the universe, ritual, elemental weapons, the Holy Graal, Abrahamadabra, the gestures, Our Lady Babalon and The Beast, bloody sacrifice, purifications, the oath, charge to the spirit, clairvoyance, divination, dramatic rituals, black magic, and alchemy are among the many topics covered. An extensive system of appendices provides many rituals, consecrations, correspondences, readings, and other accessory material. Crowley's graphs and charts illustrate the text. (DO-23295-6 softcover 436pp \$6.50)

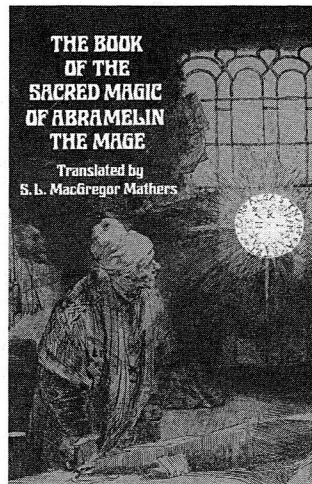

**The Book of the Sacred Magic of Abramelin the Mage** translated by S.L. MacGregor Mathers. Around the turn of the century, when Aleister Crowley was working out his system of Magick, the source that he turned to for basics was the system of Abramelin of Egypt. Abramelin, whose system is based mostly on Hellenistic theurgy of the lamblichian sort, but with Jewish increments from the Cabala, explains the qualifications needed to become a magician, purifications and asceticisms to be practiced month by month, studies and activities permitted during this period, selection of place and time for working magic, equipment needed, prayers and formulas, evocation of good and evil spirits, commanding spirits to do one's will, overcoming rebellious spirits, and similar material. Specific instructions are offered to develop such powers as clairvoyance, divining metals and treasures, warding off evil magic, healing illness, levitation, transportation, rendering oneself invisible, creating illusions and glamour, reading minds, placing compulsions, working black magic, and a host of other abilities. (DO-23211-5 softcover 268pp \$5.00)

**La-Bas (Down There)** by J.K. Huysmans. At the novel's center is Durtal, a writer obsessed with the life of one of the blackest figures in history, Gilles de Rais—child murderer, sadist, necrophile, and practitioner of all the black arts. The book's authentic, extraordinarily detailed descriptions of the Black Mass have never been surpassed. (DO-22837-1 softcover 287pp \$4.95)

**Against The Grain (A Rebouris)** by J.K. Huysmans. Because of his extreme sensitivity to the absurd and grotesque in human affairs,

the protagonist of this masterpiece of decadence has estranged himself from society and savors the most bizarre aspects of human existence in his quest for novelty. This landmark novel is filled with weird images and biting wit. (DO-22190-3 softcover 206pp \$3.95)

**Tales of Terror and the Supernatural** by Wilkie Collins. Collins's ventures into the realm of the half-dead, explorations of strange psyches and uncanny turn of chance have been compared with the works of LeFanu and Poe. These 12 eerie tales will not easily be forgotten. (DO-20307-7 softcover 294pp \$4.95)

**Little Novels** by Wilkie Collins. Fourteen stories from Collins's later period include ghost, mystery, and problem stories characterized by deftly drawn characters and ingeniously complicated plots. Collins admirers and lovers of short fiction will welcome these hard-to-find tales. (DO-23506-8 softcover 244pp \$5.95)

**The First Book of Ghost Stories: Widdershins** by Oliver Onions. Oliver Onions (1873-1961) was one of the few truly great ghost writers. Here are eight superb tales of terror and the supernatural, including "The Beckoning Fair One," considered the best single ghost story in English. (DO-23608-0 softcover 206pp \$4.50)

**Five Victorian Ghost Novels** edited by E.F. Bleiler. Reprinted here are five great classics of the supernatural genre: *The Uninhabited House*, Mrs. Riddell; *The Amber Witch*, J. Meinhold; *Monsieur Maurice*, Amelia Edwards; *A Phantom Lover*, Vernon Lee; and *The Ghost of Guir House*, Charles W. Beale. (DO-22558-5 softcover 421pp illustrated \$6.50)

**Ghost and Horror Stories of Ambrose Bierce.** Reminiscent of Poe, the Gothic novel, and the Romantic short story, but having an unmistakable individuality all their own, these 23 tales are vividly imagined, strangely prophetic, and decades ahead of their time in technical skill. (DO-20767-6 softcover 199pp \$3.95)

**The Best Supernatural Tales of Arthur Conan Doyle.** Fifteen masterfully-plotted stories. (DO-23725-7 softcover 256pp \$4.95)

# Thieves' Guild

COMPLETE RULES  
AND SCENARIOS  
FOR ROGUISH  
ADVENTURING!

BECAUSE  
SOMETIMES IT'S  
MORE FUN TO PLAY  
THE BAD GUYS!

A COMPLETE fantasy role-playing system that allows the player to assume the role of a daring thief. Simulates the dangers and rewards of a life of crime as the characters seek to outwit locks, traps, and the forces of law and order that stand between them and the treasures of the wealthy.

**Thieves' Guild.** Comes complete with rules for combat and a wide variety of thievish pursuits such as lockpicking, locating traps, using disguises, ransoming prisoners, even the fencing of stolen goods and the simulating of a medieval justice system. Also included are three well-detailed scenarios for immediate play. (GL-3901 boxed \$15.00)

**TG2: The Tombs of Shale-Chuun.** Additional rules and guidelines on using hirelings and magic, and an expanded combat system. The scenario section challenges players to brave the deadly Tombs of Shale-Chuun—two complete tombs and a ruined temple are included. (GL-1902 64pp \$7.95)

**TG3: The Duke's Dress Ball.** Players infiltrate the Duke's Ball to mingle with the aris-

toocracy, with detailed descriptions of over fifty personalities and a variety of subplots, or attempt the burglary of a mage's tower. New rules look at pickpocketing and lockpicking, and the effects of drunkenness. (GL-1903 64pp \$7.95)

**TG4: Rogues' Roost.** Three scenarios challenge players as the Thieves' Guild and its notorious rival, the Black Hand, battle for supremacy in Haven's underworld. New rules include discussion of two new character abilities, dealing with informants, and tailing. (GL-1904 48pp \$6.50)

**TG5: The Radisha Must Die!** New rules for the use of armor and shields in combat. Players may explore the recently discovered tomb of an ancient master of illusion, or try to infiltrate orc territory in an attempt to assassinate the *Radisha*, the promised messiah of the orc tribes. (GL-1905 48pp \$6.50)

**TG6: Scourge of the Seaways.** Rules on designing and sailing ships, sea chases, boarding actions, and determining cargo values. A region of the world and its trade

are provided as a setting for piracy adventures, as well as thirty complete ship descriptions. (GL-1906 64pp \$7.50)

**TG7: The Claw Of Frithnath.** Rules on inborn characteristics and a detailed discussion of locks and lockpicking. Players can attempt to penetrate the underground forge of a mighty dwarven enchanter, or attempt to find the carrier of a magical artifact among the passengers and employees of a caravan. (GL-1907 48pp \$6.50)

**TG8: The Secret of the Crystal Mountains.** Ten new highwaymen encounters, and rules for bows and other missile weapons. Players can follow the nomads of the Golden Plateau to the legendary Crystal Valley, or they can try to penetrate the lair of a clan of trolls to rescue maidens held captive. (GL-1908 32pp \$5.95)

**TG9: Escape from the Ashwood Mines.** Players engineer a daring jailbreak from the notorious penal mines of Ashwood to rescue a Guild lieutenant. Also, the conclusion to "The Secret of the Crystal Mountains"—now that the players have found the crystals, will they be able to find a way out? (GL-1909 32pp \$5.95)

**TG10: Bandit Gangs and Caravans.** Rules for setting up bandit gangs to prey on the wealthy merchant caravans, and for designing cargo and passengers to plunder. Players can teach a lesson to a defiant merchant who has refused to make his "protection" payments to the Thieves' Guild. (GL-1910 36pp \$5.95)

Available thru Sleuth. Use order form on page 39. Dealer inquiries welcome.

# The Free City HAVEN

Available thru Sleuth.  
Use order form on page 39.  
Dealer inquiries welcome.



## THE MOST EXTENSIVE URBAN ADVENTURE CAMPAIGN EVER CREATED

WELCOME TO Haven, where opportunities for adventure await in every tavern and on every street corner! Whether your players lust after political power, seek a place to spend the loot from their last expedition, or simply want a change of pace from the same-old-dungeon-doldrums, Haven can provide an exciting spark of life to your campaign that neither you nor your players will want to miss!

### HAVEN: THE FREE CITY

Presents 124 shop descriptions, 77 major personalities, 16 major families, 9 major & minor religions, 25 scenarios, 60 random encounters, 10 neighborhood maps, and a poster-sized color map of the whole city. (GL-3930 boxed \$20.00)

Coming: HAVEN 3 (Summer/Fall 1987)

### HAVEN 2: SECRETS OF THE LABYRINTH

Provides 4 Black Hand guild descriptions, 8 ships, 58 major personalities, 78 shops, 14 scenarios, 15 Thieves' Market vendors, 30 random encounters, 10 neighborhood maps, and a description of the Thieves' Guild. (GL-1931 80pp \$12.95)

## CONTINUE YOUR ADVENTURES WITH THE WORLD OF HAVEN CAMPAIGN MODULES

### CITY OF THE SACRED FLAME

Presents the historical background of the city of Zal' Akhen, and describes its political structure and its major figures, the Cult of the god-king Zat'ak and its major members, the Arena and its gladiatorial combat, the Bazaar and its denizens, the city's merchants and points of interest, the Gauntlet and its indigents, two scenarios, and ten random encounters. (GL-1934 48pp \$6.95)

### WITHIN THE TYRANT'S DEMESNE

Describes the fortress city of dhar Ankhes and the land of Samil; the three groups of its power elite—the Tyrant and his household, the Darknight Brigade, and the Sovereign Society; eight points of interest—the Plaza of Samil, Wizard's Walk, the Wood Market, Merchant's Row, Trader's Market, the New Market/Highwater Street, the Riverfront, and Glazier Street; and ten city encounters. (GL-1935 48pp \$6.95)

### LAIR OF THE FREEBOOTERS

Describes the notorious pirates' lair of Sharlit's Hole on Brown's Island in the Bircean Sea, and how to get there. Describes seven ships and their corsair captains, Trade Town and its personalities and places of interest, the Web and its personalities and gambling dens, Morghan's Watch and its ships and places of interest, three scenarios, and 18 random encounters. (GL-1938 48pp \$6.95)

# FOR GAMEMASTERS ONLY

## Maps & Character Stats for Using the Solo *JADE JAGUAR* as a Gamemastered Adventure



By  
David L. Arneson

Maps rendered by  
Helen Doward

Illustrated by  
Michael Adams

### REBEL'S CAMP

#### JUAN HERNANDEZ

ST 14 IQ 10 LK 14 CON 12 DEX 14  
CHR 13 SPD 10 H/M adds: 6/0

SKILLS: Jungle Survival 1; Explosive  
Devices 1; Pugilism 3.

WEAPONS: Razor 1; Obsidian  
Dagger (2D6).

#### JUAN HERNANDEZ as a ZOMBIE

ST 18 IQ 10 LK 14 CON Infinite  
DEX 10 CHR 3 SPD 7 H/M adds: 6/0

SKILLS: Explosive Devices (Removing  
Fuse).

WEAPON: None.

#### JUAN HERNANDEZ as ITZPAPLOTL

ST 18 IQ 15 LK 14 CON 12 DEX 14  
CHR 6 SPD 18 (Flying) H/M adds: 6/0

SKILLS: None.

WEAPON: Claw (4D6).

NOTES: If she takes 50+ points of damage  
in one round, she is neutralized for one full  
movement round.

#### GUARDS

(All in green jump suits and berets)

#### NATIVE GUARDS

ST 10 IQ 9 LK 9 CON 15 DEX 10  
CHR 10 SPD 10 H/M adds: 8/0

SKILLS: Jungle Survival 1; Pugilism 2.

WEAPONS: Uzi 1; Native Blowgun 2.

#### FINSTER'S GUARDS

ST 10 IQ 9 LK 9 CON 10 DEX 12  
SPD 10 H/M adds: 3/0

SKILLS: Jungle Survival 1.

WEAPON: .357 Magnum 1.

#### SACRIFICE GUARDS

ST 10 IQ 9 LK 9 CON 16 DEX 10  
SPD 10 H/M adds: 3/0

SKILLS: Jungle Survival 1.

WEAPON: Uzi 1.

### NATIVE VILLAGE

#### NATIVES

ST 10 IQ 10 LK 10 CON 10  
DEX 10 SPD 10

H/M adds: 0/1 (bow)

SKILLS: Jungle Survival 2;  
Ambush 1.

WEAPONS: Native Bow (2D6) 1;  
Dagger (1D6) 1.

#### NATIVES as JAGUARS

ST 10 DEX 10 SPD 20  
H/M adds: 6/0

SKILLS: None.

WEAPON: Claws (4D6).

### THE EXPEDITION

#### PROFESSOR JACKSON

ST 10 IQ 14 LK 9 CON 12 DEX 10  
CHR 10 SPD 10 H/M adds: None

SKILLS: Jungle Survival 2; PhD in Anthro-  
pology (Meso-American Cultures).

WEAPONS: None.

NOTES: Considered to be "friend" by the  
local native tribe.

#### HERMAN FINSTER

ST 9 IQ 12 LK 8 CON 9 DEX 10  
CHR 11 SPD 9 H/M adds: None

SKILLS: Desert Survival 1 (+1 to CON in  
arid areas); Masters Degree in Anthropology.

WEAPONS: None.

#### OTHERS

ST 10 IQ 10 LK 10 CON 10 DEX 10  
CHR 10 SPD 10 H/M adds: None

SKILLS: Jungle Survival 1; various Anthro-  
pological and Archaeological skills.

WEAPONS: None.

## 16A: Rebel's Camp

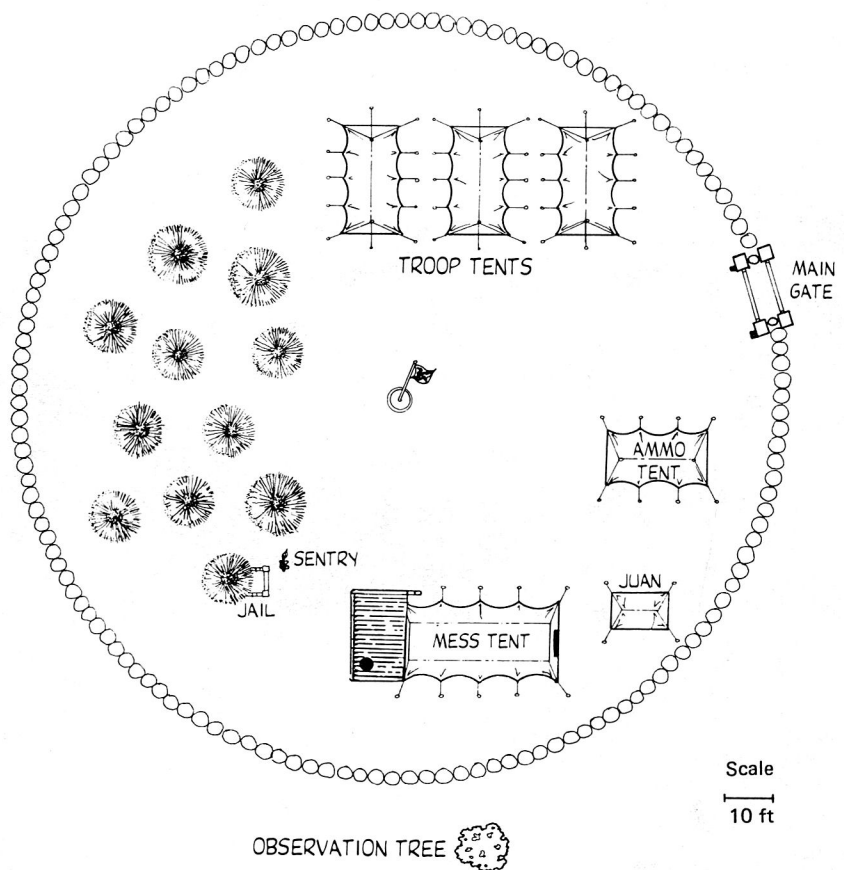

# 16F: Temple Ruins

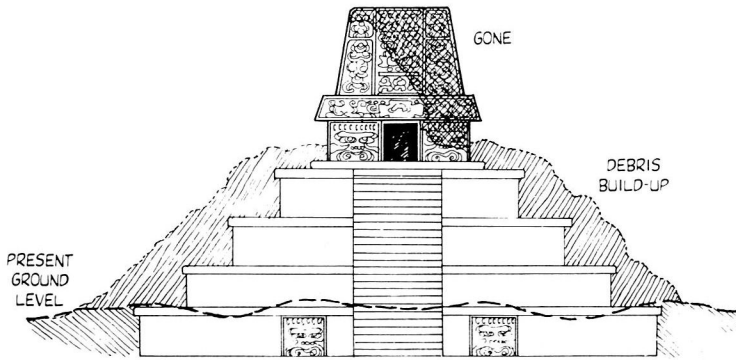

VISIBLE PORTIONS OF RUINS OF JADE JAGUAR

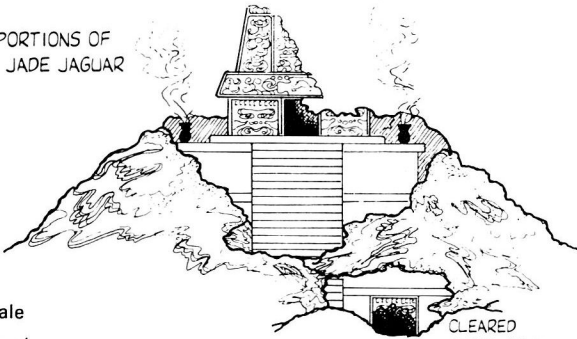

Scale  
10 ft

OVERHEAD VIEW

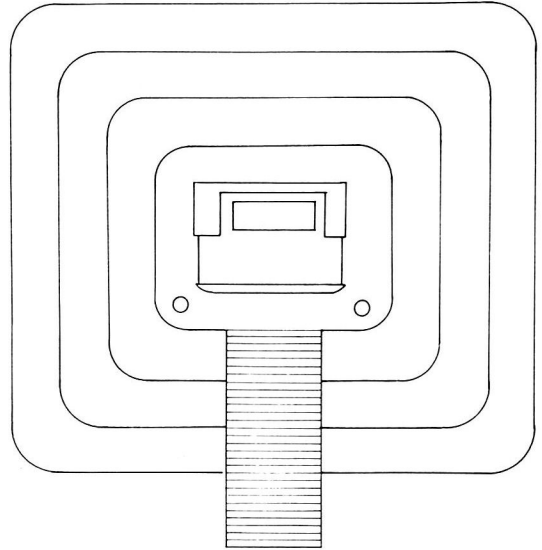

EDGE OF JUNGLE

# 12D: Native Village

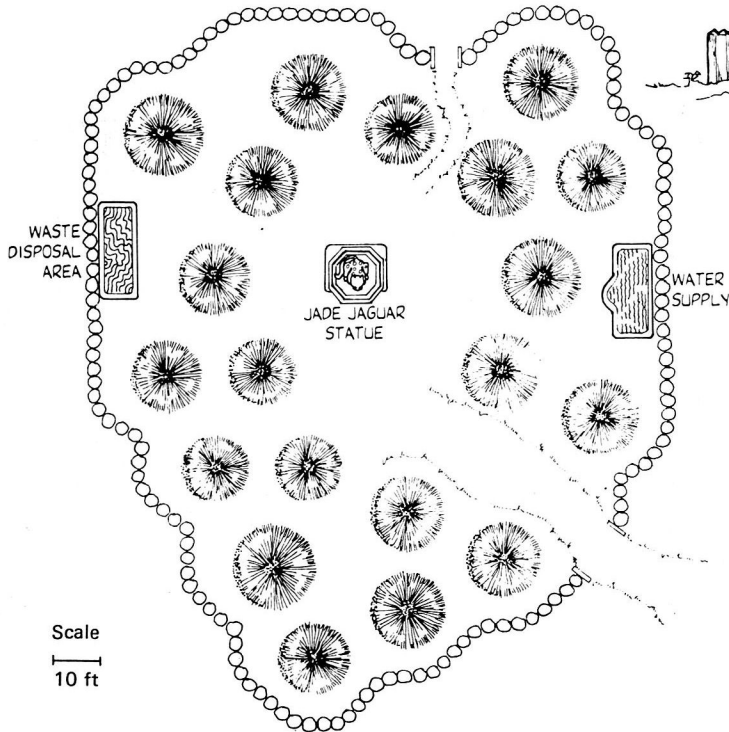

Scale  
10 ft

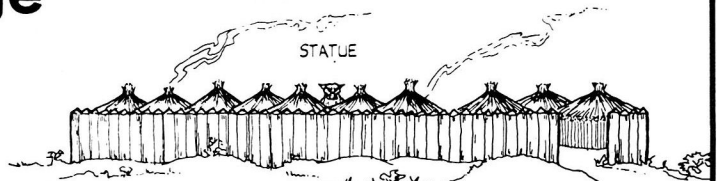

NATIVE VILLAGE (SIDE VIEW)

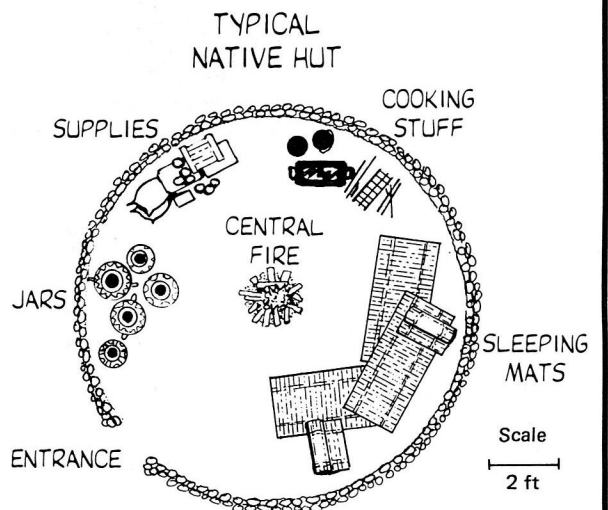

Scale  
2 ft

# FOR GMs ONLY

## LATIN AMERICAN ARMY CAMP

### CAPTAIN K. ORTEGA

ST 10 IQ 11 LK 10 CON 15 DEX 10 CHR 11 SPD 9  
H/M adds: None.

SKILLS: Cards 2; Leadership 1.

WEAPONS: .357 Magnum 1.

### CORPORAL I. GONZALES

ST 10 IQ 10 LK 12 CON 12 DEX 13 CHR 12 SPD 10  
H/M adds: None.

SKILLS: Jungle Survival 3; Pugilism 2 (3 adds for HTH);  
Driving 3.

WEAPONS: Native Bow 2; Native Blowgun 2; Knife 1; M16 1.

### GUARDS

ST 9 IQ 9 LK 9 CON 10 DEX 10 CHR 9 SPD 10  
H/M adds: None.

SKILLS: Cards 1.

WEAPONS: M16 1; Bayonet 1.

### [1] GIANT ANACONDA

ST 15 CON 18 DEX 15  
SPD 3 H/M adds: 3/0

WEAPON: Bite (1D6).



### THE JADE JAGUAR

ST 24 IQ 17 LK 14 CON 50  
SPD 26 H/M adds: 5/0

SKILLS: Jungle Survival 10.

WEAPON: Claws (8D6).

NOTE: Missile fire has no effect  
on the Jaguar.



# Latin American Army Camp

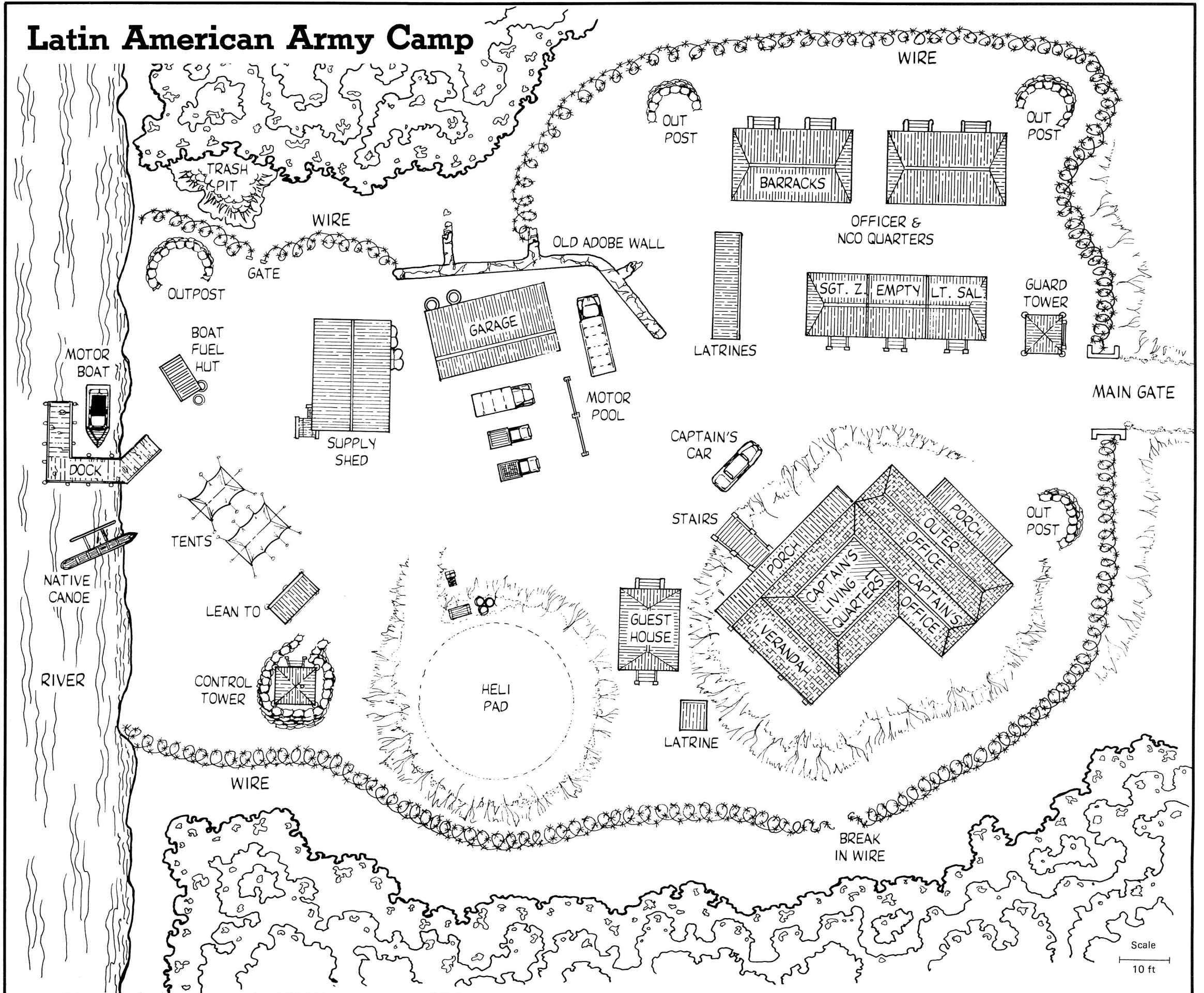



Special DIFFERENT WORLDS Module for

# JAMES BOND 007

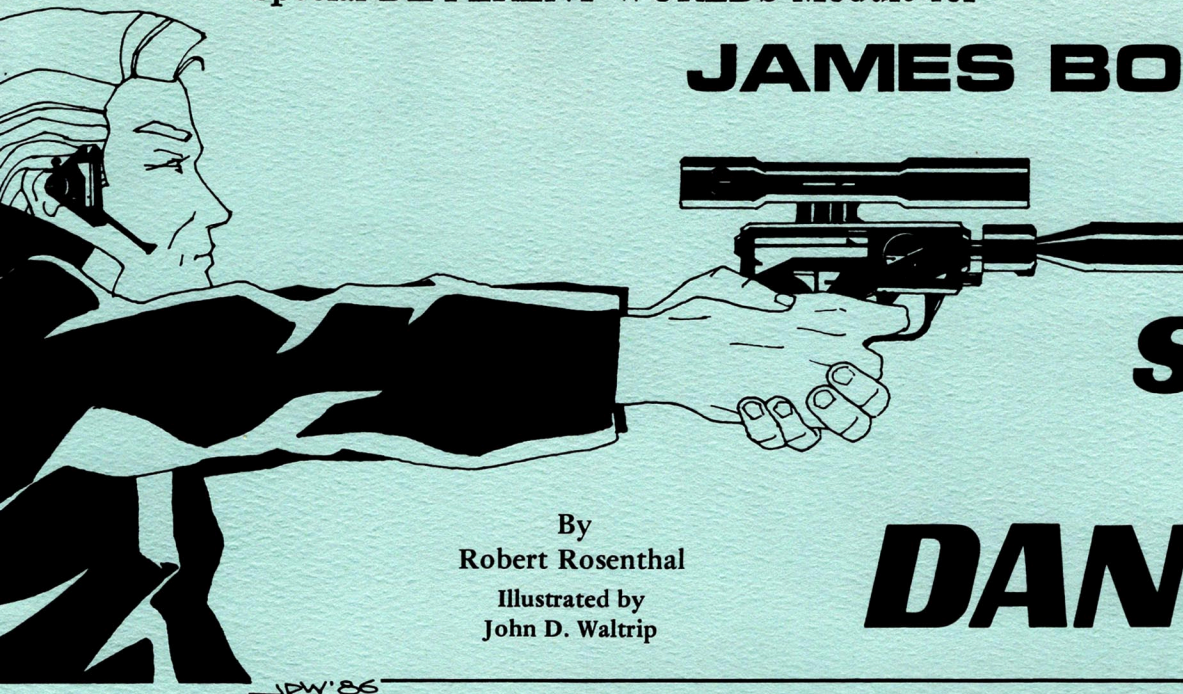

## THE SOUNDS OF DANGER

By  
Robert Rosenthal

Illustrated by  
John D. Waltrip

### M.I.6 HEADQUARTERS

IT IS Thursday the 7th of June. The agents arrive at M's office at 8pm. Miss Money Penny shows them in. The briefing is a set of nine points:

- [1] Professor Feodor Ikonovych contacted our man in Leningrad last week indicating his desire to defect. He is the Soviet's leading scientist on experimental energy.
- [2] He has promised to make whatever arrangements necessary to aid in his escape.
- [3] The Professor will be in East Berlin at the Stadt Berlin Interhotel for an energy conference of the Eastern Bloc countries for one week.
- [4] You are to contact him and effect his escape without bloodshed.
- [5] Your contact in East Berlin is Doug Bremer. He is the

proprietor of a tavern called Mutters.

- [6] You will make arrangements with the Professor to get him out of East Berlin. You will identify yourselves as wine dealers from Universal Import/Export. He will respond by offering you a glass of pre-war Rhine wine.
- [7] Once the Professor is in West Berlin you are to see he makes it safely to our consulate. Then you are to go to your hotel and wait.
- [8] After the Professor announces his defection publicly, you will be assigned by the embassy to bring him safely back to London.
- [9] See Q Branch for any equipment you might need. Miss Money Penny has a file for you on the Professor and will make your travel arrangements.

#### BRIEFING FOR THE GAMEMASTER

The adventure would be quite easy if it were not for the powerful criminal organization known as TAROT (Technological Accession, Revenge & Organized Terrorism). They will learn of the plan to rescue the Professor from Opal Isopyra, an agent they have coerced into betraying her comrades by holding her daughter hostage. She is Doug Bremer's bar maid and right-hand confidant.

The play of the game will depend much on what the agents choose to do and when. There is a certain flow that should be maintained whenever possible. The agents should meet their contact in East Berlin before attempting to see the Professor. They should then contact the Professor. After contacting the Professor, they may find they are being kept under surveillance by Soviet security. After the Professor disappears, the Soviet security team should always be one step behind the agents. The Soviet security team should be used to unwittingly aid in destroying the TAROT base.

#### Q BRANCH EQUIPMENT

Q will be found working late as usual on a jet platform with Dr. Powell. As the agents enter they will overhear Dr. Powell remark that he wished they had one of the TAROT models to study. The agents should be allowed any equipment on the standard-issue list on page 79 of the Basic Game book and one of the attaché cases for no experience cost. They will also be outfitted with some new equipment ready for field testing. A small easily concealed lockpick will be placed against their wrist. It is held there by a flesh-colored synthetic wrist wrap. By flexing the wrist all the way forward, it will force the lockpick to drop into the palm of the agent. It provides a -4 Ease Factor concealment value. There is a -3 Ease Factor to pick handcuffs behind one's back. While any other equipment may be wheeled out of Q, the agents should not load themselves down this early in the adventure. Remind them that they are going into East Berlin and will be subject to a very thorough search upon entering the country.



## BERLIN

TO ENTER East Berlin a visa is required. A visa will be issued at the border for agents with confirmed reservations. A transit visa will be issued for people just traveling through the German Democratic Republic for 72 hours. For further information on Berlin see *For Your Information*, pp 58-59, or a good travel book.

The Stadt Berlin Interhotel is 37 stories tall and has 955 rooms. It has meeting facilities for 500 that will be filled to capacity for the conference. The most notable difference while the conference is going on is the guards at the intersection to all the meeting rooms. The Professor and the energy conference are being held at the Stadt Berlin Interhotel. A Hero Point will allow an agent a persuasion roll to procure an empty room. A Quality Rating of one or two is required to be successful.

### MUTTERS TAVERN

The contact and proprietor of the tavern is Doug Bremer. He has three rookie operatives to aid him: Pitor Viley, Stephan Shymanik, and Opal Isopyra who is a double agent for TAROT. All spy business is conducted in the wine cellar. Doug can arrange papers, weapons, whatever is needed, usually within 12 to 24 hours. Pitor and Stephan are used for strongarm; at the tavern they are waiters. Opal is the bar maid and tends bar whenever Doug has business in the wine cellar.

When the agents first arrive at the tavern, Opal will be serving the clientele and Doug will be tending bar. After the agents identify themselves as wine dealers from Universal Imports, Doug will invite them to sample a bottle of prewar wine he has stored down in the cellar. He will tell Opal to watch the bar and to have Pitor and Stephan come out of the kitchen to wait on the customers. Once downstairs, Doug will pour them a fine Rhine wine. He will then explain what he needs to get the Professor out of East Germany. When the agents have the Professor, they are to bring him back to the tavern. The Professor will then be disguised as an American tourist and slipped aboard a midnight tour bus from West Berlin. One of the agents will accompany him while the rest follow in a rent-

ed car. It departs at 1am from the Marx-Engels Square.

When the agents come back upstairs, Opal will attempt to seduce the most attractive male agent to find out their plans. She will use this knowledge to form an ambush, probably at the tavern. However, the final decision will be dictated by the agents' actions.

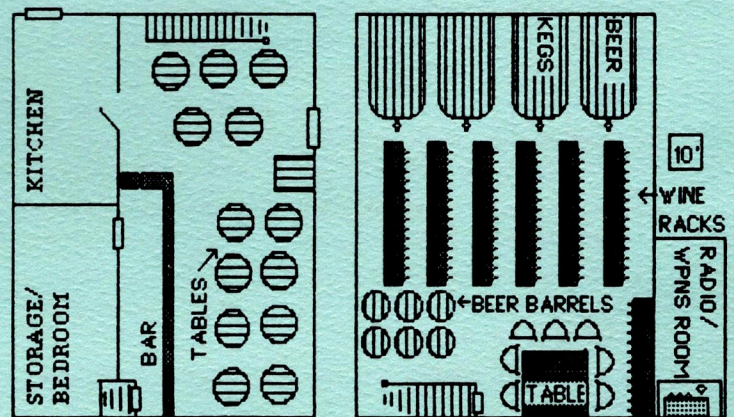

MAIN FLOOR

CELLAR

Secret room behind sliding wine rack.

### CONTACTING THE PROFESSOR

Anything the players can think of to contact the Professor should be given a fair chance of working. If they cannot figure out something, allow Doug Bremer or Opal Isopyra to give them an idea. Doug will advise the agents to sneak a member into the conference disguised as a scientist. If this option is used, they should enter during the Professor's speech. . . .

### PROFESSOR IVONOVYCH'S SPEECH

"... Before I show the film on my work, I think it best to explain how isomerismic energy works. Isomerismic energy uses sound waves with the identical atomic weight and mass as the compound it displaces. Please run the film and I will narrate the scenes you are about to see."

The light go out and the film starts up with only the Professor's voice being heard over the projector.

"Since sound waves can move through any substance and are nonpolluting, they can be the perfect form of

energy for mass transportation. Here is an example of a toy car being moved solely by the sound waves from a tuning fork. Under similar conditions and a larger scale, the arm of this crane is being slowly moved by sound waves. As a final demonstration of the power of isomeric energy, I will allow the film to speak for itself."

A picture of a bowling ball is shown resting on a table. It slowly begins to vibrate increasingly more violently until after a half a minute or so when it crumbles into dust. The lights come on and the Professor stands up on the platform.

"Like the bowling ball a tumor might be removed without the need for internal surgery. Only time, money, and hard work is needed to make this the energy of the future."

## CONVERSATION WITH THE PROFESSOR

The Professor has already figured out the perfect spot for the agents to free him from his Soviet guards. "On Sunday, I will be taken to an illegal gambling house owned by the state. It is for the pleasure of important German and Soviet officials. While the conference is going on, it will be opened to members of the KGB, a select group of scientists, and their guards. I've been there once before. The guards at the exit make sure that we leave with the guards we entered with. I should arrive there at 2100 but it doesn't get crowded until 2300 or so. After that I should no longer be under the scrutiny of my guards. You need only find a way of getting in and getting me out without arousing suspicion."

The Professor will offer whatever other aid he can but the agents will have very little time with him as he is under constant surveillance.

## THE ABDUCTION

The most convenient place for the agents to abduct the Professor is at the gambling house. Doug Bremer should know as much as needed to aid the agents in any questions they may have about the gambling house. If they have their own ideas, then use them and have them suffer the consequences. Doug will suggest they go as KGB agents and take the Professor out of there with forged papers. He will have the papers ready just in time for the agents to get to the gambling house by 11pm.

There are two guards at the door of the gambling house checking everyone's documents as they enter and leave. The place is packed with leading Eastern scientists, guards,

KGB agents, and . . . Red Grant. The Professor will be at the bacarat table. Red Grant will notice the agents leaving with the Professor but will take no action unless he recognizes them from a previous encounter. At the door the guards will ask to see their orders. The Professor will make a show of being reluctant to leave, but all will go according to plan. From here the most likely place for the agents to go is the tavern.

When the agents arrive, Opal will be tending the bar. She will hurry them downstairs. Pitor and Stephan are tied and gagged upstairs in their rooms. There are four TAROT operatives hiding downstairs with M10s, and one in the kitchen who will keep watch on anyone staying upstairs; otherwise he will follow the agents down. Doug is drugged and tied to the chair. A gun battle will most certainly result in the agents' deaths and should be avoided at any cost.

The TAROT agents will tie up everyone but the Professor. Opal will come to say goodbye, leaving a clue for the agents. "Sorry it had to end like this, Doug, but as the rock star Bob Seeger once said, 'gotta get out of here, that's what I'm gonna do.'"

As they leave, they will set the tavern afire. The agents have ten rounds to escape from the inferno. They must make an Ease Factor 2 dexterity roll to untie themselves, and Ease Factor 6 to untie someone else. The Quality Rating of their roll is the number of rounds it will take to become untied. Doug is drugged and unable to untie himself, although he will mumble something about Stephan and Pitor upstairs.

The Professor's disappearance won't be noticed until the next morning. If the agents were seen with him, they will be wanted for interrogation. The agents could find where the Professor was taken by checking what flight he boarded with Doug's forged passport. This will take a couple of days. An easier method is to ask Doug about the remark Opal said prior to leaving. He will explain it's from a song about going to Kathmandu by some rock star she used to listen to.

The TAROT agents drive to West Berlin with the Professor, taking the first flight out, connecting in New Delhi for Kathmandu. If the agents call in they will be instructed to get the Professor back. If additional agents are desired they will meet them in Kathmandu. Red Grant and his colleagues will be one day behind the agents in getting to Nepal. If they know who the agents are, then they will spot them at the airport in Berlin and attempt to follow them to the Professor.

## GAMEMASTER CHARACTERS

**DOUG BREMER:** STR 10, DEX 7, WIL 7, PER 11, INT 12. Age: 58. Appearance: Attractive. Skills: Fire Combat 12; Disguise (Forgery) 15; Hand-to-Hand Combat 15.

**OPAL ISOPYRA:** STR 6, DEX 7, WIL 7, PER 7, INT 8. Age 32. Appearance: Sensational. Skills: Fire Combat 10; Piloting 10; Boating 9; Hand-to-Hand Combat 8; Evasion 10; Seduction 10.

**PITOR/STEPHAN:** STR 9, DEX 8, WIL 6, PER 8, INT 7. Age 27. Appearance: Attractive. Skills: Fire Combat 12; Hand-to-Hand Combat 12.

**PROFESSOR FEODOR IVONOVYCH:** STR 6, DEX 6, WIL 5, PER 8, INT 14. Age 68. Appearance: Plain. Skills: Science 21; Electronics 18.

**RED GRANT\*:** STR 13, DEX 12, WIL 10, PER 10, INT 9. Age 33. Appearance: Good Looking. Skills: Fire Combat 25; Hand-to-Hand Combat 26; Torture 21; Interrogation 19; Disguise 18.

**MAJOR NICHOLAS BURKE\*:** STR 13, DEX 10, WIL 13, PER 11, INT 12. Age 42. Appearance: Normal. Skills: Fire Combat 23; Hand-to-Hand Combat 25; Piloting 19; Interrogation 21; Boating 20.

**BULAWAYO/SAGAR:** STR 13, DEX 10, WIL 10, PER 8, INT 6. Age 32. Appearance: Normal. Skills: Fire Combat 16; Hand-to-Hand Combat 17; Torture 16; Piloting 14; Boating 13.

**RUSSIAN/TAROT GUARDS:** STR 7, DEX 7, WIL 5, PER 7, INT 5. Age 19-39 (add +3 for Security Team). Skills: Fire Combat 11; Hand-to-Hand Combat 10; Evasion 9; Boating/Piloting 8.

\*For additional information see the Basic Game book.

*As each adventure will be played slightly different, only the most basic skills are given above. The gamemaster should flesh out the characters to suit his campaign.*

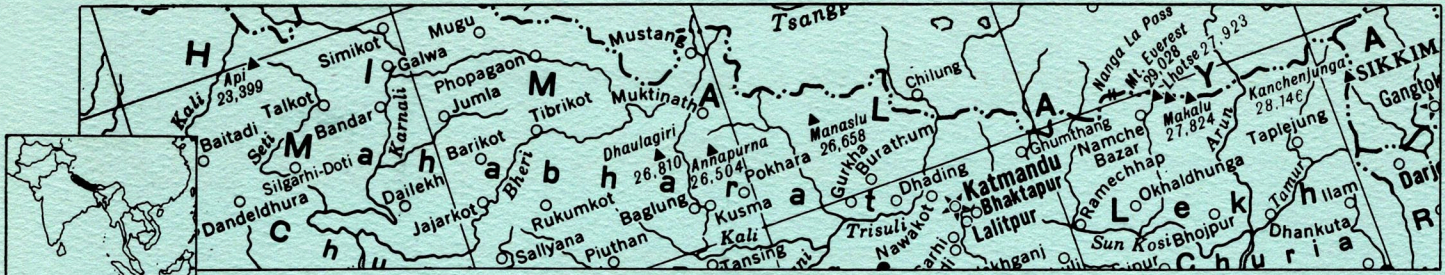

# KATMANDU

TO FIND the professor, the agents will need to ask around at the airport. One of the cabbies will tell them: "A helicopter from the Nepali Corps of Engineers came and picked up six men and a lady, probably to work on the dam at Trisuli Bazaar."

To go up to Trisuli Bazaar, or to pass there, requires a trekking permit, which takes 48 hours or more to obtain. Relations with Nepal are edgy at best, so London will not be able to speed up this process, whereas a bribe might. The reason for poor relations is because TAROT has a

power hold over the king of Nepal. All visas go through TAROT personnel. A trekking visa obtained with a bribe would negate TAROT seeing it, but would not reveal TAROT's hold on the royal family.

TAROT has a neutron bomb hidden in the old palace of Kathmandu. They will explode it unless King Birendri does exactly as TAROT demands. Their plans are to explode the bomb while a foreign dignitary is visiting. They hope to gain total control of this small mountain kingdom and further their aim of causing unrest throughout the world. The Vice President of the United States will make an unscheduled stop on his Asian tour while the agents are at the TAROT complex.

## TRISULI BAZAAR

There are two ways up to Trisuli Bazaar: helicopter or automobile. To drive up to Trisuli, they can take a taxi or a four hour crowded bus ride up the winding roads. Either way should prove to be an uneventful trip. There is only one charter helicopter service available to the agents if they wish to fly up to Trisuli Bazaar. It is Bobji's Flying Rhino, and is operated by a member of TAROT. The pilot will fly them up past Langtang, on the Tibetan border. He will ask the agents to fetch him some water from a nearby stream or some other diversionary tactic. Once they are far enough away, he will take off, firing a couple of shots to alert any nearby Chinese patrols. If the agents manage

to avoid the patrols, they will reach Langtang. In Langtang, if an agent asks about the Nepali Corps of Engineers, he will be told they are working by the Gosainkund lakes. The pilot has also hired thugs (see "The Bridge") to stop the agents from reaching Gosainkund. He will tell TAROT he has killed the agents.

If the agents reach Trisuli Bazaar, they will find nothing except the hydroelectric plant and the Nepali Corps of Engineers. If they ask around they will find out that, for the past three or four years, work on the water runoff problem is being done by a special branch of the Corps up at Gosainkund. Once or twice a month, a helicopter lands here on its way there.

## THE TREK TO GOSAINKUND

The trek to Gosainkund is a strenuous walk along mountain pathways from one village to the next, where food and shelter may be found. The map shows the name of each village where the agents will find food and shelter. The numbers correspond to the number of days hike it is from Trisuli Bazaar. As the agents make their way up through the Himalayas, they will notice the great beauty and grandeur around them, not to mention the strain of climbing through the mountains. A -1 Ease Factor on all rolls for the first three days should be used to illustrate the strain the agents are having due to the elevation. Any book on trekking or photographs of the Himalayas will prove very helpful to add realism to the agents' hike up.

[1] TRISULI BAZAAR.

[1A] BETRAWATI: A small village two hours from Trisuli up a long stair case carved into the natural landscape.

[2] RAMCHE: A small village where food and lodging can be found.

[2A] THE BRIDGE: See next section.

[3] DHUNCHE: A village with a hand-woven clothing factory.

[4] SYARBRUBENSI: This village has a hot spring nearby and Tibetan refugees.

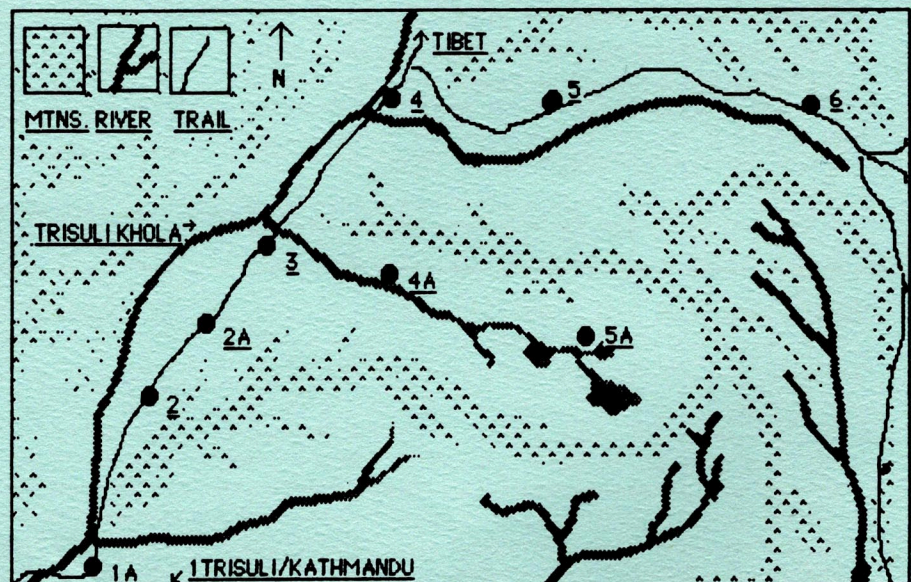

[4A] HUTS: Vacant huts for trekkers on the way to Gosainkund.

[5] SYARPRA: A picturesque village where the yaks can first be seen grazing in the fall and winter months.

[5A] GOSAINKUND: The lakes and TAROT's complex are here.

[6] LANGTANG: There is a cheese dairy here and a small inn for trekkers. From here the agents are only three miles to the border of China. If they go any farther north, they will run into 2-20 Chinese border guards. They are identical to the Soviet guards and carry number 4 rifles.

## THE BRIDGE

From Ramche, on the way to the Dhunche, the agents will have to cross one of a multitude of small bridges, only this one is a trap. It's a rope bridge spanning 20 feet across a 2000-foot drop to the river below. There is sufficient cover around for a small army to hide. On an Ease Factor 5 sixth sense roll, the agent will know someone is hiding in the rocks on the other side. There are four Tamang natives hidden on the opposite side of the bridge. They

have cut a part of the rope on the bridge so it will hold no more than 150 lbs. Anyone on the bridge will have to make an Ease Factor 2 dexterity roll to grab on to the bridge when it falls. The Tamangs will wait until the first person is across and the others are crossing to attack. Once the bridge is down, an Ease Factor 3 mountaineering roll is needed to climb along the rock face to get to the other side of the chasm.

The Tamangs have Gurka blades (+2 Damage Class). Their stats are as follows: Mountaineering 9; Evasion 7; Hand-to-Hand Combat 8 (Damage Class A).

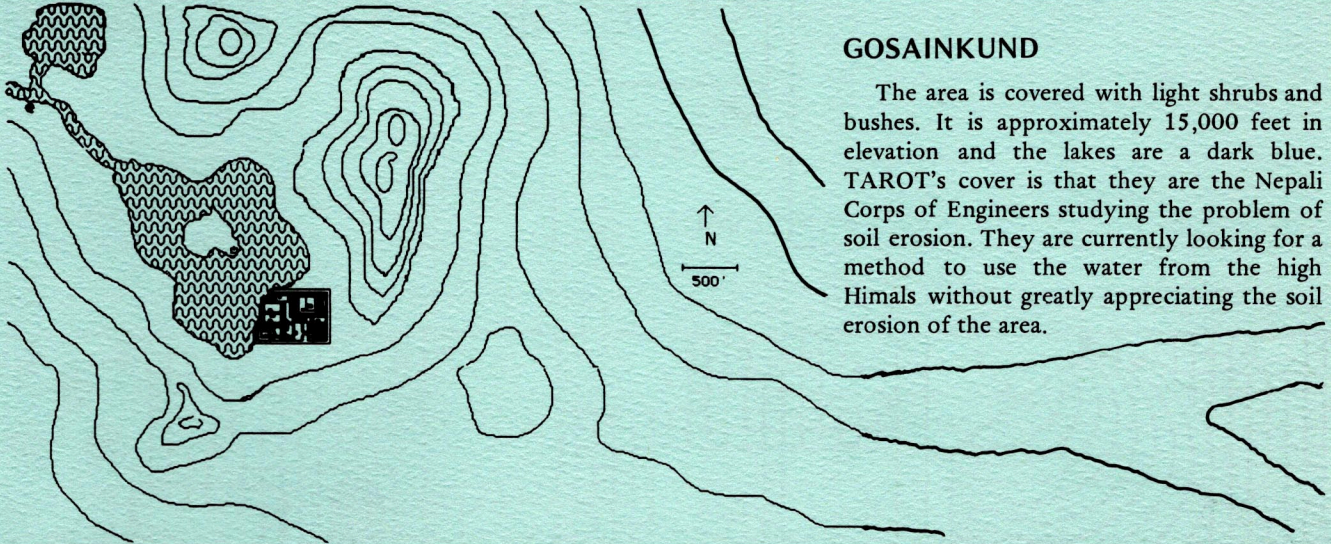

## GOSAINKUND

The area is covered with light shrubs and bushes. It is approximately 15,000 feet in elevation and the lakes are a dark blue. TAROT's cover is that they are the Nepali Corps of Engineers studying the problem of soil erosion. They are currently looking for a method to use the water from the high Himalas without greatly appreciating the soil erosion of the area.

## THE COMPOUND

The Compound is surrounded by two 12 foot-high wire fences 10 feet apart from each other. In front of the compound are several excavation holes. All of the building in the compound are made of corrugated steel except for buildings 5, 6, and 11, which are made of concrete blocks.

- [1] FENCE AND GATE: The gate is manned by two guards 24 hours a day. The fences have seismic detectors that register in building 11, the main office.
- [1A] GUEST HOUSE AND GUARDS QUARTERS: If anyone bluffs their way in to visit, they will be put up for the night here. The building houses the six guards from the gates and has two extra rooms.
- [2] GATE HOUSE.
- [3] GUN TOWERS: One guard in each tower with an M-2.50 calibre Browning machine gun hidden under a tarp. A rope ladder leads up to the towers.
- [4] BARRACKS: Quonset-hut style.
- [5] OFFICIAL VISITING QUARTERS: A two-story barracks for TAROT operatives visiting.
- [6] TRAM STATION: On the outside, this building appears identical to building 5. The windows are shuttered and the door has a -2 Ease Factor lock on it. Inside the building is a second building with a five-foot walkway between the two buildings. The door to the second building and the door to building 5 has a key-board lock on it. The code is "0001." Inside are four pairs of scuba gear and two underwater trams leading to the Island. One carries personnel, the other

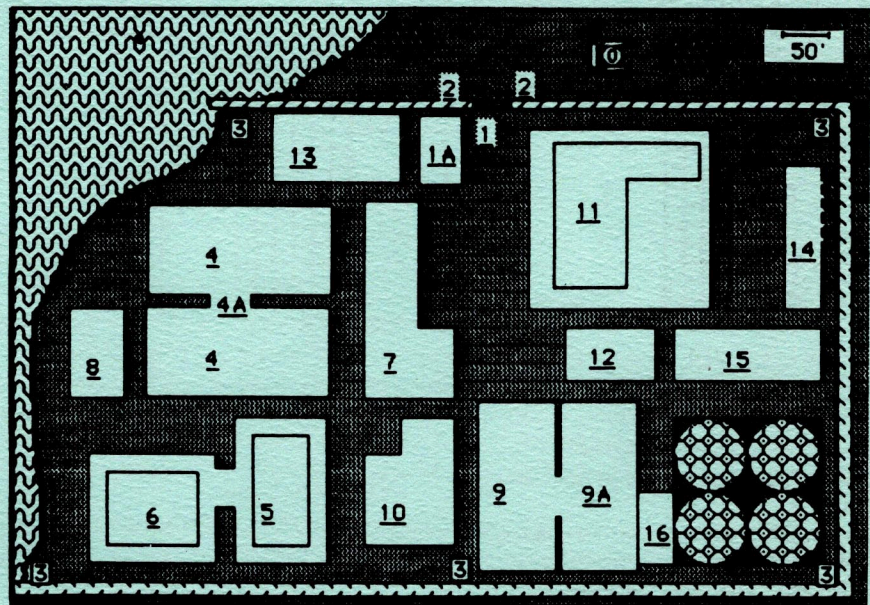

- carries cargo. The personnel tram has room to carry thirty people comfortably and has a wet bar.
- [7] MESS AND KITCHEN.
- [8] GENERATOR.
- [9] STORAGE AND SUPPLY SHEDS. Clothing, cleaning equipment, etc.
- [9A] Same as 9 but contains mostly weapons and ammunition.
- [10] KITCHEN SUPPLIES: Cooking utensils and fuel.
- [11] H.Q. OFFICE: A two-story brick building that is the headquarters for the compound.
- [12] GUARDS' RECREATION QUARTERS.
- [13] OFFICERS' RECREATION QUARTERS.
- [14] STABLES: Houses horses and two yaks.
- [15] SMALL VEHICLE STORAGE: Auto scooter and sleds for moving equipment around are stored here.
- [16] HELIOPAD AND OFFICE: A large tent can be extended from the office to cover the heliopad. If the agents decide to wage an all out attack, give TAROT an Apache helicopter under the tent.

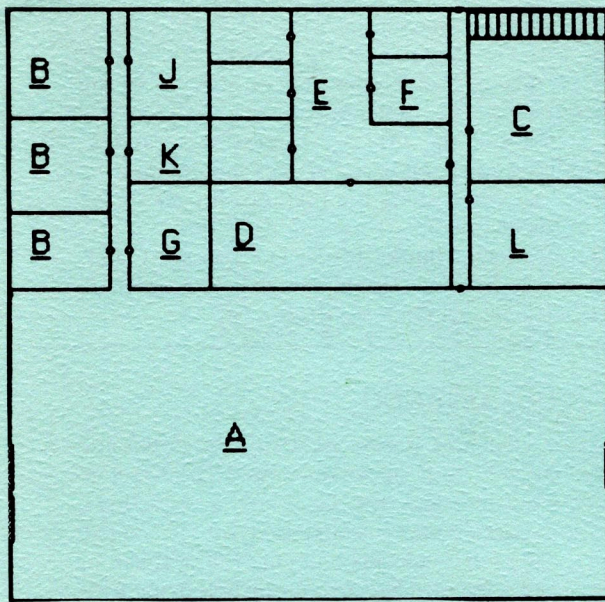

**BLDG 11: H.Q. OFFICE**

- [A] OPEN AREA: For briefings. There are two tractors here currently.
- [B] OFFICES.
- [C] MAJOR BURKE'S OFFICE.
- [D] GUARD ROOM: For cell area.
- [E] CELLS.
- [F] Previously captured OO agent (optional).
- [G] BEDROOM: Empty.
- [H] SUPPLY CLOSET: Linen, towels, etc.
- [I] MAP ROOM: The map of the whole TAROT base and Island is on the wall, but may be copied.
- [J] SUPPLY CLOSET: Cleaning equipment and supplies.

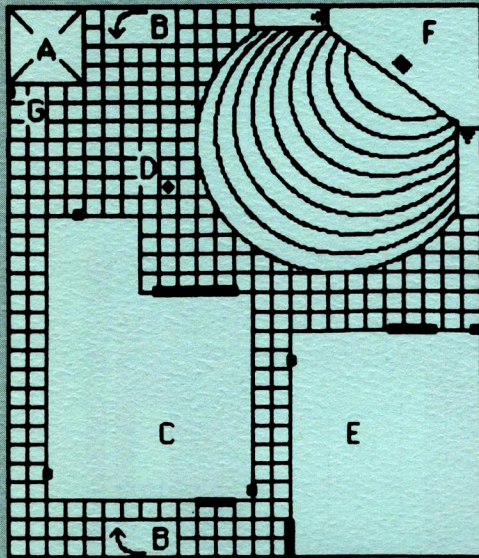

**LEVEL 1**

**LEVEL 1**

- [A] ELEVATOR: From surface to level 4.
- [B] RAMP: Golf carts are used to go from level 1 to level 5.
- [C] STORAGE: This building contains building materials, machinery, etc.
- [D] STATUE OF SKORPIOS AND GREYHOUND: A camera and microphone are in the statue.
- [E] STORAGE: This building has a -1 Ease Factor lock and contains transportational storage. Inside are three 14-man river rafts, eight jet platforms, two skorpions, two rocket belts, and four Dynafoil Mark 1's.
- [F] AUDITORIUM WITH SMALL STAGE: For briefings and entertainment.
- [G] IRON RUNG LADDER: To hut on surface.

**LEVEL 2**

- [A] ELEVATOR: From surface to level 4.
- [AA] ELEVATOR: Operates from level 4 through level 6.

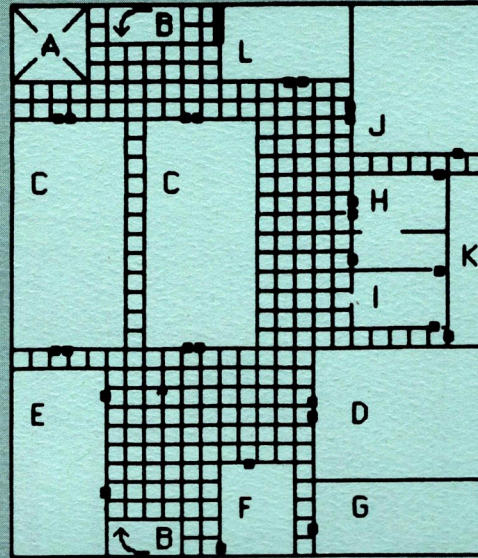

**LEVEL 2**

**LEVEL 2**

- [B] RAMP: Golf carts are used to go from level 1 to level 5.
- [C] GUARDS BARRACKS: Barracks and showers for twelve guards.
- [D] TECHNICIANS BARRACKS: Barracks and showers for ten technicians.
- [E] SCIENTISTS BARRACKS: Barracks and showers for eight resident scientists.
- [F] BOXING ARENA AND WORKOUT AREA.
- [G] MARTIAL ARTS WORKOUT AND TRAINING ROOM.
- [H] CLASSROOMS.
- [I] WEIGHTROOM.
- [J] KITCHEN/MESS HALL.
- [K] FIRING RANGE.
- [L] GOLF CART STORAGE.

**LEVEL 3**

- [A] ELEVATOR: From surface to level 4.
- [B] RAMP: Golf carts are used to go from level 1 to level 5.

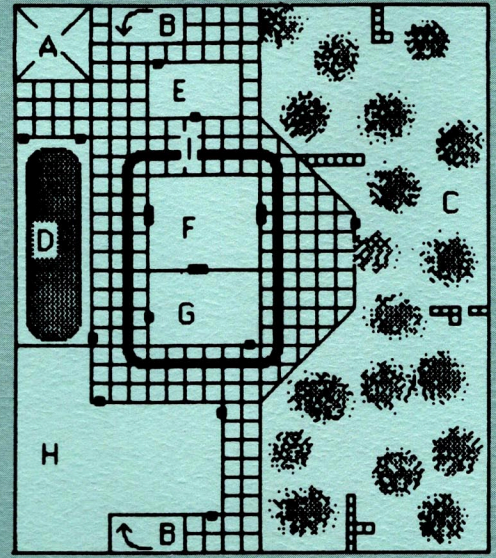

**LEVEL 3**

- [C] THE GARDEN: New agents gain field experience in this garden where trees, bushes, and walls provide natural cover. A captured agent will be brought here to be killed by new recruits of TAROT. The agents will be placed in here one at a time with five guards hidden in the surrounding cover, each with a different non-firearm weapon. The guards are dressed in black ninja gear. The agents will be given red ninja outfits. It is possible for the agents to kill one of the guards and switch clothing. This process will be repeated for each agent with the guards being sent back in and any additional guards to bring the total back up to five to one. See "Island Tour" section.
- [D] SWIMMING POOL.
- [E] INFIRMARY.
- [F] GYMNASTICS.
- [G] FENCING.
- [H] GENERAL OFFICE/LAUNDRY/COPIERS/ADDITIONAL CLASSROOMS.

**Scale: 1 square = 5'**

[K] WEAPONS ROOM: -2 Ease Factor lock.

[L] RADIO ROOM: Manned 24 hours a day. A TAROT code book is on the desk.

[M] LATRINE AND SHOWERS.

[N] MAJOR BURKE'S ROOM: Inside a -1 Ease Factor locked

closet is a jet platform. A lever on the inside of the closet will blow off a portion of the roof allowing for the Major to escape on the jet platform.

[O] BULAWAYO'S ROOM: Major Burke's bodyguard.

[P] SAGAR'S ROOM: Head of security on the Island.



The agents will either be taken to the Island, if captured, or will find their own way there. If the agents are having trouble, point out that the island does not show on their map, or have them overhear two guards talking about taking the last of the equipment over to the Island tonight. From shore, the island appears to be nothing more than a jutting peak with a makeshift wooden hovel and a small row boat.

The island is solid rock and supports no plant life. Anyone on the island with mountaineering or science skills

## ENCOUNTERING MAJOR BURKE

If anyone is caught snooping around the camp, one of two actions will be taken. If there is sufficient cause to believe the agents are nothing more than curious trekkers, they will put the agents up in the visitors' shack under light guard. The next day they will have a helicopter take

will get an 8 Ease Factor roll to determine that it is man-made. The wooden hut is 30'x40' and has no windows. Inside the hut is a table, chairs and a small pantry with a sack of rice. On a 3 Ease Factor, or upon close examination, a 6 Ease Factor perception roll, an agent will notice that the whole east wall is removable. Behind it is a ball-bearing ramp that lowers into the lake outside. In the same area the agents will notice a 20'x20' area on the floor that forms the roof of the elevator to the levels below. On one side, the floorboards are removable, revealing a 5'x5' hatch with a ladder leading down.

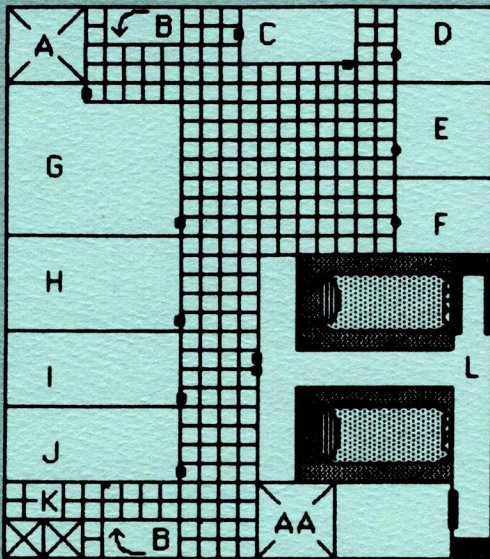

LEVEL 4

### LEVEL 4

- [A] ELEVATOR: From surface to level 4.
- [AA] ELEVATOR: Operates from level 4 through level 6. It is operated from the level 6 control center to carry necessary cargo down.
- [B] RAMP: Golf carts are used to go from level 1 to level 5.
- [C] SCIENCE LABS STORAGE.
- [D] CLASSROOM.
- [E] THINK TANK: For scientists to discuss ideas and for use as briefing room.
- [F] CHEMISTRY LAB.
- [G] VEHICLE REPAIR: With two hydraulic lifts.
- [H] WEAPONS LAB.
- [I] COMPUTERS LAB.
- [J] MICROCIRCUITRY REPAIR AND MANUFACTURING.
- [K] ELEVATOR: Operates from level 4 to level 6 only.

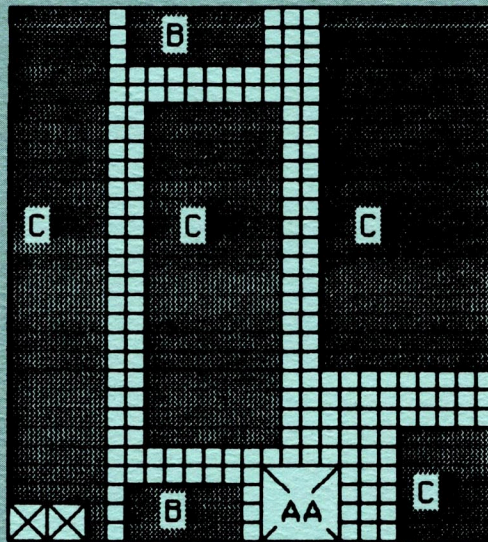

LEVEL 5

### LEVEL 5

- [L] TRAM DEPOT: Keyboard lock on all doors leading into and out of the trams, each with different combinations. There is usually one tram here at a time. Along the back wall are full override controls and an unloading dock for the elevator.
- [AA] ELEVATOR: Operates from level 4 level 6. It is operated from the level 6 control center to carry necessary cargo down.
- [B] RAMP: The ramp ends here with two heavily padlocked steel doors.
- [C] ENERGY HOUSING AND CONTROLS: For the Island complex.

### LEVEL 6

- [A] VISUAL CONTROL CENTER WITH ALL OTHER TAROT BASES AND OPERATIONS: The controls to the nuclear bomb are in this room.
- [AA] ELEVATOR: Operates from level 4 through level 6. It is operated from the level 6 control center to carry necessary cargo down.

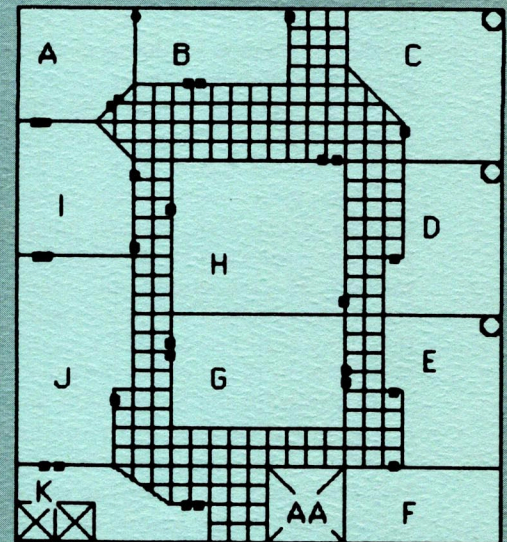

LEVEL 6

- [B] SECURITY ROOM: There are always two guards on duty here.
- [C] MAJOR BURKE'S ROOM: In the corner of the room is a small closet that contains a jet platform that is launched in an emergency escape pod that breaks apart once it breaks the surface of the water. Major Burke is not usually here and will not use the pod due to his claustrophobia.
- [D] DR. ISA NAKAHARA'S ROOM: See the Major's room for escape plan.
- [E] OPAL'S ROOM: See Major's room for escape plan.
- [F] PROFESSOR IVONOVYCH'S ROOM.
- [G] SECURITY GUARDS ROOM: Eight Ghurkan guards maintain order on the base.
- [H] THE PROFESSOR'S LABORATORY.
- [I] COMPUTER BANKS AND MONITORS.
- [J] LIBRARY.
- [K] ELEVATOR: Operates from level 4 to level 6 only. There is also a small reception area with one guard at a desk to check security for all personnel entering this level.

the agents to Trisuli Bazaar or Langtang. Everything will be done to convince the agents that the compound is nothing more than an ideal location for the Nepali Corps of Engineers to perform their tests on the soil. Major Nicholas Burke will be interested in talking to the agents to find out more about them over dinner. He will tell the agents he was originally with the Peace Corps; hence the title Major. If the Major has reason to be suspicious of the agents, he will arrange an accident similar to the helicopter ride up to Langtang. If his suspicions are confirmed, he will lock the agents up in the H.Q. cells for interrogation. After a few hours of interrogation the Major will order the agents killed unless they have made a reference of interest to TAROT, i.e., the Island, Professor, etc. Once the Major's interest is piqued, he will offer them a personal tour of the island in hopes of convincing the agents to work for TAROT.

## THE ISLAND TOUR

The Major, along with two guards per agent, will tram to the Island. They will take the elevator to level 1, giving the agents a full tour down to level 3. He will then show one of the agents into the garden, soundly closing the door behind them. The Major's voice booms over a loud speaker explaining to the agent the test they are to undergo to prove their worthiness to TAROT.

"You have ten minutes to orient yourself. You will find a red ninja outfit in front of you. I suggest you put it on as I speak. It will allow you greater stealth, shielding you from your enemy. At the end of the ten minutes I am sending in five men in black ninja outfits to try and kill you. They will each be armed with a different non-firearm weapon. If you should kill them, then you are truly worthy of TAROT's employment. If they should win, then they shall move up to a place of honor as one of the Island's security team. Let the games begin!"

This process will be repeated one at a time for each of the agents. If an agent is victorious, he will be kept with the Major where a careful watch will be maintained. The Major will have the victorious agents taken to the guards' barracks to change before meeting with him for dinner and a brief orientation. They will be accompanied by one more guard than there are agents. If the agents refuse to join TAROT, the Major will offer them time to reconsider over dinner, keeping them under heavy guard at all times. After dinner, they will be handcuffed and taken to see the bomb detonated.

If they are disguised as one of the guards upon coming out of the garden, they will be told "Report to Sagar on level 6. You will be issued new uniforms and weapons there. From now on you're a member of TAROT security on this island." Sagar is the chief of security and will assign the new guards to the visual control center on level 6 after they have rested.

## DINNER WITH THE MAJOR

After the agents are refreshed, they will be shown to the Major's room where he and Opal Isopyra are already seated before a well prepared meal. He will ask them to sit down and to help themselves to whatever they like. On a 4 Ease Factor perception roll, the agents will notice that Opal is terribly uncomfortable around the Major. As the meal progresses, the Major will begin to brief them on the Island and TAROT's immediate plan at hand.

"You have an opportunity to switch sides at a most fortuitous time. With one bold move TAROT will destroy

the working relations between the Soviet Union, the U.S.A., and China. In exactly 2 hours, the Vice President of the United States will begin a tour of the old palace of Nepal conducted by none other than the reigning King. We have had the foresight to plant a small nuclear device there; which we have previously used to get the King to let us operate unhampered. You will have the privilege of watching us detonate it. Our own people have already infiltrated into the Nepali government and will take power upon the King's death. They will also turn over papers to the various governments that will incriminate both the Soviets and Chinese in the conspiracy. Our friends in the crime syndicate have prepared for some damaging evidence to leak out showing that it was the CIA that had placed the bomb. And with the seeds of dissension planted, the cold war will heat up; TAROT's strength will increase and men such as ourselves will become of great value." Opal will say very little during the whole meal, but she will apologize for trying to kill the agents, explaining that she had to do then what was necessary. When she makes this apology she will look imploringly into the agent's eyes that she had played up to before. On a successful sixth sense, the agent will realize that TAROT has some hold over her. After all the conversation is finished, the Major will say "Let us finish our drinks and then to the control room."

## THE VISUAL CONTROL CENTER

The agents should either be disguised as guards or handcuffed guests of the Major. This is an excellent time to use their lockpicks if they still have them. There will be two more guards than captured agents. Bulawayo will already be waiting in the control room with the Professor when they arrive. He will whisper something to the Major who will then excuse himself to take care of more pressing matters. The Major will hand Bulawayo a red key as he leaves. Bulawayo has just informed the Major that a Soviet assault team is heading towards the base.

The Professor will tell the agents how the bomb is to be detonated. "The neutron bomb is armed with a safety device to prevent detonation. A sound wave generated at the correct pitch will destroy that device causing the bomb's immediate detonation. A high-pitched squeal will be their only sound of danger. The red key is a tuning fork designed to generate that perfect pitch. Thirty seconds after the key is inserted, the power will build up to a sufficient level to reach Kathmandu. Only a total power shutdown can stop it."

As soon as the first agent is free, Bulawayo will insert the key. If the fight starts to go against them, Opal will come to their aid. The quickest way to stop detonation is to actually pull out the key; otherwise the gamemaster should, at his or her discretion, decide how to achieve a complete power shutdown.

Opal will lead the agents to her room where her 7-year-old daughter is. She will show the agents the jet platforms and how to use them. Once the agents reach the surface, they will find themselves in the midst of a firefight. They should be chased by any and all forms of transportation available to TAROT; jet platforms, skorptions, dynafoils, etc. If they manage to live through the ensuing firefight, they will find out that they have to turn over the Professor to the Soviets. He'll be happy to go back. Things were much quieter in the Soviet Union, and he can work without the threat of death over his head. The kingdom of Nepal will be forever indebted to the agents. □



# Game Reviews

Middle-Earth Role Playing/The Revised Recon/Elfquest/The Elfquest Companion/Sea Elves/Countdown To Armageddon/Four Horsemen of Apokolips/Free City of Krakow/Coriolis Effect/Cthulhu By Gaslight/After The Bomb/Adventures!/High Seas/Lee's Guide to Interstellar Adventure Volume 1/Book of Treasure Maps/The Breeder Bombs



## MIDDLE-EARTH ROLE PLAYING

By S. Coleman Charlton  
(ICE \$10)

Reviewed by Jonathan Tweet

*MIDDLE-EARTH Role Playing* brings participants to the most fascinating modern fantasy world, Tolkien's Middle-Earth, much of which the people at ICE successfully represent. The game rules, derived from ICE's popular *Rolemaster* series, are well thought out and detailed. Unfortunately, the setting and the game rules mesh poorly, facing players with a choice between faithfulness to Tolkien's genius and fully using the game mechanics.

*MERP* nicely brings Middle-Earth to role-playing. Here is a game with authentic, despicable Orcs, conservative Hobbits, and a variety of wondrous Elves. Don't settle for the pale imitations that populate too many fantasy games; *MERP* offers the real thing. And the monsters are rightfully horrible, including the fearsome Wights, dread Nazgul, and the terrible Balrog, which is capable of tearing an enemy in two. As is to be expected, Middle-Earth makes a fantastic game setting. Though the rulesbook mentions little about the political or physical geography of Middle-Earth, ICE sells campaign and adventure books that provide such information.

The rules are generally detailed and appealing. Players can have characters from a wide variety of well-described races, sub-races, and ethnic groups. The six attributes are determined on percentile dice. Each character has a class: warrior, scout, ranger, bard, mage, or animist. Though abilities are guided by the character's class, the player retains much control in determining specifics and in altering character development when wished, both when generating and when advancing the character.

The combat rules are thorough, with different types of weapons

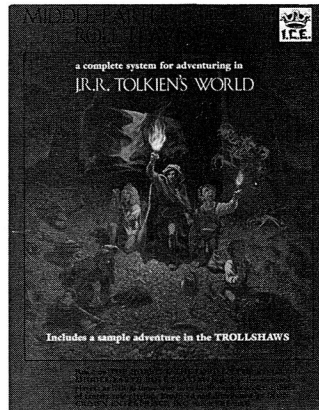

having different effects and different relative usefulness versus the various types of armor, regulated by the use of many percentile charts. The critical and fumble tables allow for a great range of colorful results, from stumbles to shattered skulls, adding detail and sometimes grim humor. Charts are inherently limiting and cannot encompass all possibilities, so the results sometimes oppose common sense, but these charts generally function well.

The experience system is also detailed, with good points and bad. Experience points are awarded for a healthy variety of activities, including travel and disarming traps, all modified by how new or routine the action is, but perhaps the experience system is too detailed and comprehensive. Characters get experience for each critical wound they deliver, for each mile traveled, and for just about any action that requires some roll, even clearing rubble from a treasure chest.

The magic system is intriguing. Characters learn lists of related spells from which they can cast spells of their level or below, with a daily limitation based on innate magical ability. Animists and mages learn lots of magic, rangers and bards learn from their own lists, and even fighters and scouts can pick up a few spells. Attack spells have their own charts much like the weapons charts and are resolved in similar fashion to armed combat.

To attempt a non-combat, non-spell action, a player rolls percentile dice, adds skill and attribute bonuses, and applies a modifier for the action's difficulty. The result and the appropriate chart determine how successful the attempt is. This system is flexible, but relies heavily on the game-

master's judgment of each action's difficulty.

What keeps *MERP* from being a four-star game is that the beautiful setting and intricate game rules do not match. Fantasy games have been heavily influenced by the example of *Dungeons & Dragons*. Typically, an adventuring group comprising several races and classes wanders around a fantasy world blasting monsters with big spells and winning lots of magic items, and when someone gets killed they dish out some money and get the character back to life. *MERP* was designed to be played this way.

As a gamemaster, one would have to be willing to rise above the designer's expectations to capture the true flavor of Middle-Earth. Monster-trashing and dungeon-looting are available in any home-made world, but Middle-Earth should inspire players to causes more noble than self-aggrandizement.

What is worse than the implied style of play are the rules that are positively against a faithful rendering of Middle-Earth. "Ranger" becomes a generic profession, not the ethnic group to which Ara-

gorn belonged. More ill-fitting is the prevalence of magic. The idea of spells being as common-place as the game would have it is a sad concession to role-playing tradition and it cheapens Middle-Earth. The rules throw up a scanty facade of rationalization to explain this mismatch and limit magic use, but the example adventure and my personal experience clearly show that magic gets used like it does in any other fantasy setting. An ambitious and skilled gamemaster could remove magic from the system, but not without putting much work into rebalancing the game.

But most gamers are not purists like me. *MERP* can be played as is if you do not mind a compromise between Tolkien's genius and role-playing habits. It is a complete, workable system that can be expanded both with *MERP* game aids and the more complex *Rolemaster* rules. Whether you want to add your sword to the side of the Free Peoples in their desperate war with Sauron or just want to kill some honest-to-Tolkien Orcs for a change, this could be the game for you. □



## THE REVISED RECON

By Erick Wujcik, et al  
(Palladium \$14.95)

Reviewed by Scott Dollinger

*THE REVISED Recon* is Palladium's contribution to the growing number of action/adventure role-playing games set in contemporary times. *Recon* focuses primarily on the type of adventures that small-unit military teams, such as those that fought in Vietnam or modern-day mercenaries, would be engaged in. The original rules for the *Recon* miniatures combat system are also included as a bonus feature.

The authors of *The Revised Recon* have done an excellent job of reconciling the authenticity of the subject matter with the simplicity necessary to make the rules easy to learn and run. This was accomplished chiefly through excellent research of the subject matter. The designers knew what type of tactics, units, and ordinance were used during the Vietnam conflict and have incorporated enough information into the



design of the game to give it authenticity and left out enough superfluous detail to make it playable. A good example of this is the character generation system.

Each character finishes basic training and must then choose two Military Occupational Specialties (MOS) from a list of nine. The specialties were chosen to reflect the type of training that was common to units in Vietnam and is comprised of the following skills: demolitions, grenadier, heavy weapons, intelligence, medic, pigman (machine gunner),

## GAME RATINGS

- ☆☆☆☆ Superb
- ☆☆☆ Mighty Fine
- ☆☆ Good
- ☆ Flop

point, radiotelephone operator, and sniper. Each specialty is colorfully described and the function of each specialty within the unit is explained so as to give the player enough information to play the character authentically. An example of simplicity of the system is the character generation itself.

Percentile dice are rolled for each of the three—that's right only three—character stats: strength, alertness, and agility. All of the other usual character stats are combined in one of the three. For example, the constitution stat, which is so common in other games, is incorporated into the strength stat which is also used as a measure of how much damage a character can take before death

occurs.

One reason for keeping character stats to a minimum may be due to the fact that the heavy damage caused by modern weapons makes fatality very likely over the course of several adventures and it is simply faster to generate characters this way. In any event the system seems to work fine and one doesn't really miss all the other stats.

After the character picks his primary specialty, secondary skills in small arms, heavy arms, hand-to-hand, and non-weapon skills are also chosen. Once again there are more than enough skills available to produce a well-rounded, authentic-feeling character.

The designers also have included a great deal of information about

the military ordinance of the modern age. Our own ordinance as well as the enemies' are listed in great detail and all forms of weaponry from side arms to jets, tanks, and missiles are given.

The combat system as a whole is fairly straightforward and does not warrant undue commentary, however, *The Revised Recon* presents a rather unique attempt at universalizing hand-to-hand and hand-held weapon attacks into one coherent system. Six attack options are listed for both: slash, stab, parry, riposte, grapple, and evade. The system works fairly well although it takes some time to get used to the new nomenclature for hand-to-hand attacks.

Besides designing units for Vietnam type operations, *The Revised*

*Recon* also provides information on the way in which mercenary groups are run. Additional skills for mercenaries, pay rates, and methods of getting weapons and ordinance are provided as well as general guidelines for desinging and running mercenary adventures.

*The Revised Recon* also includes information on fictional countries in where suitable adventures may occur with appropriate information on climate, terrain, political systems, and the state of the military in these nations. There are also fourteen "Nam" adventures and two mercenary adventures provided in full detail making *The Revised Recon* a marvelous value.

□



## ELFQUEST THE OFFICIAL ROLEPLAYING GAME

By Steve Perrin, et al  
(Chaosium \$20)

## THE ELFQUEST COMPANION

By Richard Pini, et al  
(Chaosium \$6)

## THE SEA ELVES

By Elizabeth Cerritelli  
(Chaosium \$6)

Reviewed by Michael DeWolfe

*ELFQUEST*, THE comic series, is the creation of Wendy and Richard Pini (aka WaRP Graphics). The popular series features a band of elves, called Wolfriders, and their journey through the World of Two Moons following the quest of their young chieftain, Cutter. Over the twenty issues of the initial series (with a sequel series out now), the Wolfriders encountered the other known tribes of elves; met and battled trolls; and evaded and befriended humans, their ancient enemies. Over all this, they (and the readers) learned the tribe and all elf-kind were not standard fare. All elves originating from an ancient starfaring race that, through accident and treachery, became trapped on a brutal and primordial world; draining the magical powers that supported them in space for countless millenia. They became splintered as a race, losing power and knowledge, and degenerating into their individual and unique tribes. Such is the world of *Elfquest* and the basis of the Chaosium game and the two supplements reviewed herein.

There are two books, a map, a book of character sheets, and an

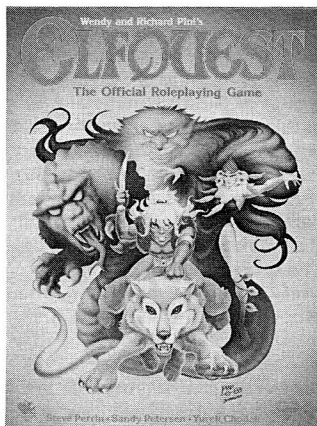

example of play provided for *Elfquest*. The Elfbook describes everything pertaining to players:

The game is based on the Chaosium system; it can be likened to a simplified version of *RuneQuest 3*. Characters have seven characteristics: Strength, Constitution, Size, Intelligence, Power, Dexterity, and Appearance. These are combined to form derived characteristics. Base chances for skills are defined by combining certain characteristics or multiples of these. Skills are percentile-based, their success or failure garnered by a D100 roll. Skills and characteristics can be increased through experience and forms of training. Because most elfin characters in *Elfquest* are practically immortal, age plays a role in Previous Experience, and increase characteristics and skills before play begins.

Combat is handled as in *RuneQuest*. Characters have one attack per round and one chance to dodge or parry. Attacks may be replaced by either of the latter, but not vice-versa. Each combat round is divided into a twelve-second period with ten Strike Ranks. The Strike Rank defines how soon one may attack; the sooner the better. A character's choice of weapon and his Dexter-

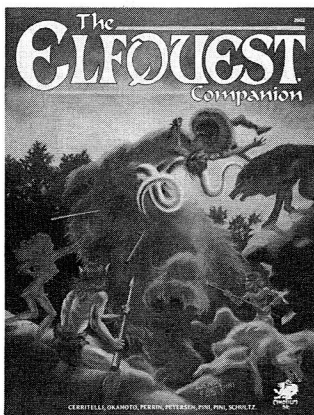

ity and Size define the Strike Rank. A dextrous and large character with a large weapon can attack much sooner than a character in an opposite case. Combat is deadly and elves are at the 'bottom of the ladder' as far as combat ability goes; trolls are at the top.

The formulae defined for generating base chances for skills, characteristics, and the magic powers received are based on what elf tribe characters choose to be born into. Each group is detailed and briefly described. Players may also choose to play humans, trolls, or preservers. Trolls and preservers are creatures that accompanied the elves on their voyages through space, taken from the elves' homeworld as reminders of how primitive they once were. Trolls are bombastic creatures, noted for cruelty, greed, excesses, and their skill with metalworking and technology—opposites of elves in almost all ways. Preservers are tiny sprite-like beings with shrill voices, colorful wings and knowledge of the elves' beginnings; knowing such, as they are ageless and almost impervious to damage.

Magic is a talent that elves alone possess. Unlike many other fan-

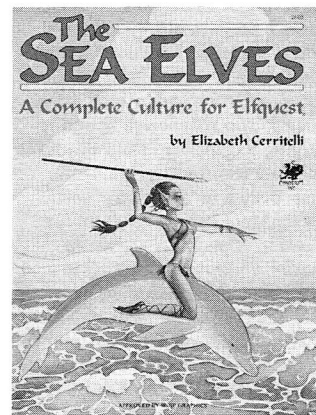

tasy games, characters do not possess, or hope to possess, a bevy of powerful spells. All elves can sense magic and most can 'Send.' Sending is a form of telepathy that allows two or more elves to convey ideas, images, and information. Sending is always voluntary—characters cannot probe minds for secrets without consent. Contact is limited to only those who can Send. Other magic powers are inherent to characters and their ancestors, usually skipping a generation to show up. Such powers are Healing, Rock-, Plant-, and Flesh-Shaping, Levitation, Hypnosis, and a half-dozen other obscure powers. The few inadequacies of this system are solved by the *Elfquest Companion's* errata section. The one problem I found with this system is that chance of success can be sacrificed for increased effects. In the comic, characters could be proficient but virtually powerless compared to one that was powerful but lacked proficiency: they couldn't mix and match chance with effects without excessive training.

The Worldbook describes rules important to the gamemaster: The book describes the effect of weather on play, falling damage,

asphyxiation, fire, heat, poison, and disease. That's about all that's needed to run a smooth game. The book goes on to detail the flora and fauna native to this moderately mundane world. Creatures are not illogical; most exist on Earth. The book completes its rules with three scenarios intended for introductory sessions of play. The first two are drawn from the comic, though full knowledge of them cannot help a player push his character to survival and success. The third scenario is original and somewhat interesting. All three are not groundbreaking and may not generate excitement and interest in the players. To find more interesting scenarios, a gamemaster has to look to the game's two supplements.

Overall, the entire game is well done. The only glitches I could find were a few mentions of the magic power Tapping which does not exist. A shortcoming I found was that no rules were found for playing a campaign set a thousand or a few thousand years in the past, only a 'present day' setting is considered. And no rules for creating High Ones are listed, though their magic powers are. A glitch also exists because of the way the resistance table works: a foot-high preserver technically has a 30% to 40% chance of lifting an average four-foot tall elf. But that is an isolated case. The maps look too sketchy and amateurish for an

otherwise outstanding example of game design.

The first supplement for *Elfquest* is *The Elfquest Companion*. The supplement features stats for 17 more characters of the *Elfquest* comic, adding to the 12 detailed in the Elfbook. Some are off-base, typoed, or lacking important stats. Treestump has a listed SIZ of 15, though Hit Points would tell his SIZ to be 5. He was repeatedly mentioned as being strong and powerful in the comic, though stat-wise he is equal to Cutter, an elf that looks physically smaller and weaker. More attention could have been paid to keeping the characters realistic in comparison to other characters and to the game system. Other features of the *Companion* include an errata for the game, but the additions only update and add rules. Two articles on elfin names and physical appearance are included. They are useful for gamemasters needing detailed characters without a lot of brainwork and for players with similar needs. They are well done and interesting. The two scenarios, "The Dying River" and "Fire Flight," are good and innovative. They work within the confines of the world and make interesting adventures; not an easy task for *Elfquest*, where much of the interest of the world relates only to what happened in the comic, with everything else seeming too mundane to be of interest.

Details on an alternative Wolfrider tribe are provided, partially as an example of how to create tribes. A piece on Wolf Ecology helps players role-play Wolfriders better. An introduction is included by Richard Pini. It boils down to saying that the world of the game does not necessarily have to be the world of the comic. An afterword by the game's designer, Steve Perrin, talks of how to bring members of tribes together and how such should be handled. *The Elfquest Companion* is almost as good as its parent game and complements it.

The second supplement, *The Sea Elves*, is a culture pack for the game. It covers tribes of elves that have taken to a string of islands far from dangerous humans. The setting is the creation of Elizabeth Cerritelli, based on her story in the fan collection of *Elfquest* stories, *Yearnings*. The tribes are groups of almost completely telepathic elves, living from the sea with their allies, the Wavedancers (read as dolphins). The book describes the islands and their natural hazards, new magic powers, and the animals native to the setting. The three scenarios dealing exclusively with sea elves, but are interesting and challenging. The first introduces elves to sea-going life. The second scenario is provided for elves that spend most of their time on the islands of the area. The third scenario involves a raid

on a small elfin island with a twist: elves can either be the raiders or the defenders of the island.

Unfortunately, this supplement is the most faulted of the three products. It looks rushed, with excessive glitches. One to point out is that a gamemaster-character, One-Arm, has both arms listed on the hit location table. Another fault is that the characters lack any specific skill for boating. What if an elf runs into a squall? He'll have to jump overboard and swim, I guess: no more is provided. However, the glitches don't ruin the supplement.

For the fans: all three products add to an *Elfquest* fan's knowledge of the characters and the world. The game and companion are filled with pieces of artwork from the comic. *The Sea Elves* and parts of the companion have original Wendy Pini artwork.

For the gamer: this is a change of pace from normal role-playing games. It doesn't focus on powerful sorcerers and multi-racial parties, nor does it involve towns and ancient castles. The setting is new but may become boring for not a few. A suggestion: don't worry about rewriting the comic with your exploits, just don't rewrite the setting or logic of the world. *Elfquest* is a good game in most facets and can be recommended.

□

## DC Heroes Modules

☆☆☆☆

### COUNTDOWN TO ARMAGEDDON

By Dan Greenberg  
(Mayfair \$7.00)

☆☆

### FOUR HORSEMEN OF APOKOLIPS

By Troy Denning  
(Mayfair \$7.00)

Reviewed by Thomas A. Grant

A LITTLE boosterism first: Mayfair's *DC Heroes* is my favorite superhero game. Without sacrificing any of the whiz-bang, rock-em, sock-em feeling of the comics, *DC Heroes* offers a simple yet elegant role-playing system which is also a lot of fun to play. From titanic battles between super-powered opponents to the mundane problems of the average hero in his secret identity, *DC Heroes* has it all. I'm therefore always eager to see what Mayfair has to offer in new supplements and scenarios for *DC Heroes*.



Concerning Mayfair's latest releases, the company is battling .500—one is very good, the other very bad. *Countdown To Armageddon* is an excellent Superman adventure, presenting a real challenge to the Man of Steel, who usually isn't bothered by anything short of Kryptonite meteor showers or the bizarre antics of Mr. Mxyzptlk. On the other hand, *Four Horsemen of Apokolips*, which pits members of the old Justice League against the avatars of War, Famine, Pestilence, and Death, has many problems,

including a set of supervillains and disasters which make the world's greatest heroes look as tough as the Hardy Boys. There's something wrong with that.

*Countdown To Armageddon* is well-written and intelligently plotted. What happens when Superman has to respond to four different disasters simultaneously? And what about the even bigger disaster waiting in the wings? Will Superman have the time to save the world from the evil plans of . . . no, I can't tell you who the villain is. Suffice it

to say that one of Superman's oldest and deadliest foes puts in an appearance. There are lives to be saved and a mystery to be solved, perfect fare for admirers of the Man of Tomorrow.

What's especially nice about *Countdown To Armageddon* are the little touches added by author Greenberg to give the scenario that extra something which enhances the role-playing experience. There are times when the world desperately needs Superman, and other times when he might jump the gun. It's both costly and undignified for Superman to race to the rescue every time a light bulb burns out or a car backfires, and *Countdown To Armageddon* forces the person playing Superman to judiciously allocate time and effort, to know when Superman is needed, and to stay in character in both of Ka-El's identities, Superman and Clark Kent. Remember, no matter what happens to Superman, anchorman Clark Kent still must make the 6pm news broadcast! *Countdown To Armageddon* even includes Clark Kent's business card, press pass, and appointment book. It's little touches like these

that make role-playing a satisfying experience.

As role-playing goes, however, *Four Horsemen of Apokolips* has little to offer. There's not much opportunity for the heroes to do a great deal more than rush off to nip the latest global crisis in the bud. Part of the problem is the number of characters involved: since you must play several super-heroes (author Troy Denning recommends using Batman, Wonder Woman, Green Lantern, Green Arrow, Hawkman, and the Martian Manhunter), it's difficult to give them equal time in their respective subplots. Wonder Woman has barely enough time to blow Steve Trevor a kiss before she dashes off to help prevent the latest dastardly machination of Darkseid, mega-villain and generally antisocial character.

Darkseid, ruler of the dirty and unpleasant planet Apokolips, has transformed four human beings into the Four Horsemen of the Apocalypse (or Apokolips, hyuk-hyuk) to act as his agents on Earth. Any one of these villains is a real match for the team of super-heroes, and it's not altogether clear why the Four Horsemen don't team up to mash the heroes into hamburger. I guess it wouldn't make much of a story, but I still don't get the logic of splitting up the supervillains.

Instead, the characters take on the Four Horsemen one at a time, at various locations across the globe. The avatar of War has manipulated world tensions and encouraged the kidnaping of all major world leaders. The heroes must save the President and the other dignitaries and then defeat War in the first part of the scenario. Next the super team must take on Pestilence, Famine, and Death, while simultaneously averting a world-wide plague and famine.

Why all this mayhem? I won't give any more of the plot away, but if you know something about Darkseid from the comics (like *The New Gods*), you can guess what he might be after. Worse, in addition to the abilities of his newly-created agents, the Four Horsemen, Darkseid himself has formidable powers, including the new super power, Continuum Control. This nifty new talent (essentially control over the basic fabric of reality) makes it possible for Darkseid to simultaneously use the powers of bio-energy blast, damage transference, matter manipulation, regathering (which resurrects characters annihilated by bio-energy blasts), regeneration, teleportation, time travel, and transformation (the power to shape organic matter into whatever form he desires). All at once!

And he will usually get initiative. And he has 60, count 'em, 60 APs worth of this talent. Why Darkseid even bothers with agents is beyond me. With this kind of power, he could strip the planet of its atmosphere, turn all super-heroes into frogs, or perform some other god-like acts with impunity.

Darkseid does appear in the adventure, and if the characters attempt to cross him, he transforms some of them into amorphous blobs of protoplasm, teleports some to Apokolips, sends a few into the future to witness the heat-death of our sun, and disperses the molecules of the rest throughout the cosmos. Then, because he's not an altogether bad villain, he reforms, regroups, and returns all the heroes, making

everything right again. He then mutters some warning about never interfering with his plans again.

If this was *Dungeons & Dragons*, we would call this the typical "El Grosso" campaign. Mega-monsters, mega-perils, and megadull. Faced with this kind of opposition, the heroes can only scamper around like frightened rabbits, hoping that the villain won't be totally nasty, or else they don't have a snowball's chance in a supernova. The situations faced by the heroes are challenging, and there's a lot of potential here for an interesting story. I would suggest that you take this at a leisurely pace, to give the characters some opportunity for role-playing. If you don't care about role-playing and you just

want to duke it out with some bad guys, then play *Four Horsemen of Apokolips* as it is. You might still tinker with some of the elements, if for no other reason than to make it more logical—eliminate Darkseid's Continuum Control powers, and invent some other rationale for the creation of the Four Horsemen, as well as a reason why they don't work together. If you make these adjustments, *Four Horsemen* will be more entertaining and certainly make more sense.

If you have just two players, yourself and someone else, I suggest you buy *Countdown To Armageddon* instead. *Countdown* is just what a *DC Heroes* scenario should be: exciting, dangerous, imaginative, and entertaining. □



## THE FREE CITY OF KRAKOW

*Twilight: 2000* Series Module

By William H. Keith, Jr.  
(GDW \$7.00)

Reviewed  
by Frederick Paul Kiesche III

*THE FREE City of Krakow* is the first independent adventure module for GDW's excellent role-playing game *Twilight: 2000*. (The original game box contained an adventure called "Escape From Kalisz" which was not so much an adventure as a detailed setting for the Polish campaign of the game.) As *Twilight: 2000* has proven to be a bestseller, I was very interested in seeing if GDW would be able to follow through with the initial excellent product. Not surprisingly, they have. *Krakow* is good.

The adventure is written by William H. Keith, Jr., and is a change for the better in his adventure plotting style. Keith has written many good adventures for other games, most notably for GDW's *Traveller*. One complaint that I always had with his adventures, however, was that they suffered from being too tightly plotted, i.e., on page 22, character no. 5 *had* to die. If no. 5 did not die, the referee would be involved in some fast footwork to keep the adventure from unraveling. Perhaps I exaggerate slightly, but many is the occasion when I felt that way!

*Krakow* transcends that method. Player-characters are (as they were in "Escape From Kalisz") American soldiers, survivors of the enemy overrun on the U.S. Fifth Division (Mechanized). They have been traveling, trying to live and link up with other survivors from their unit.

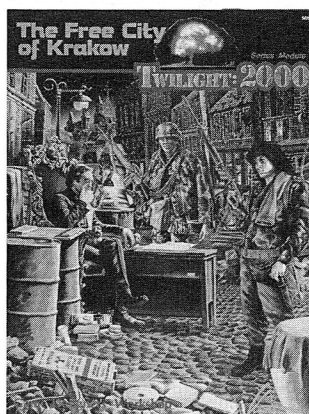

Rumors have been heard about Krakow—a city which has declared itself independent from the war, has the armed forces to enforce that declaration, and where even (it's rumored) electricity is being generated!

The characters travel toward Krakow and come across the remains of a small American military convoy. Each vehicle is riddled with bullets and stripped of valuables. The members of the convoy are all dead. The group is about to move on when they hear a moan off in the distance. . . .

From this initial situation (and several details that I won't reveal for fear of being strung up) grows the *Krakow* adventure. Instead of one tight adventure, you (the referee) are given a number of options to use. These options are mostly built from the initial situation, but many can be adopted and made into independent adventures. You need not work through the adventure once and toss away the book.

Tossing away the book would be silly indeed, because, as good as the adventure situation is, it is only peripheral to the real purpose of the book—to get you to Krakow and have adventures

there. As a "free city" (much the same as Lisbon or Casablanca during WWII), Krakow is outwardly free from the seething chaos around it. Below the surface you find plots and counterplots, agents from both U.S. governments, the KGB, the Israeli intelligence organization (the Shabak), and various independent groups. Krakow is also home to a fair amount of industry, a lot of stockpiled material and even a working helicopter!

Much of the book is taken up with detailed descriptions of the city and the people that inhabit it. Verbal descriptions of the town, various sub-sections and organizations present; encounter charts; maps and diagrams and tables describing the available military and police forces build the city up into a working social organism. Author Keith and GDW did not stop there. They also have included a map and descriptions of the various smaller towns surrounding Krakow so that player-characters can adventure around and the referee will not go insane trying to build up the local scenery and population on the spur of the moment.

Next we have a "who's who" section, describing the major personalities to be found in Krakow. Each is nicely illustrated with a small Liz Danforth sketch and contains not only a description of the person's background and personality, but tells you how that person might be best encountered. This is especially useful given the open-ended structure of the module's adventuring material.

The section on organizations, briefly mentioned above, is also crucial due to the adventure's structure—and is quite good. Each organization—the local police or militia, the town government, the

KGB, etc., is described verbally with special attention given to strengths, equipment, location, leaders, and how they might be met. Given the volatile nature of the town, it is not hard to meet most of these groups!

The section on helicopters is a welcome expansion both to the equipment available to player-characters and to the combat and skill rules. Several helicopters are described. An expansion upon the skill of "rotary wing pilot" is given to help "game" an attempt to fly. Combat details are given,

especially important aspects such as "nape of the earth flight," charts and tables needed and gaming characteristics for six helicopters and a number of weapons and ammunition for those weapons.

The book rounds off with a glossary of the important words, names and locations used in the adventure. It does not, however, contain a pronunciation guide. Considering that the game is set in Poland and I lost my ability to speak Polish several generations ago, I really would have liked to

see something like that included here!

I'd like to make note of the artwork in the module. Steve Venters's cover and interior drawings really bring the grim reality of the game out for me. The maps included, while not as detailed as those by some companies (Chaosium, for example), are more than adequate—especially when keyed to the excellent verbal descriptions. Liz Danforth's "thumbnail sketches" also help in bringing the various important gamemaster-characters to life. Artwork is

important to a game or adventure, and I'm glad to see that GDW hired some good people to fill the bill.

I recommend this module highly. If you run *Twilight: 2000*, the module is a must—careful use of the city's adventuring resources could bring hours of playing excitement. If you don't run *Twilight: 2000*, some work may be needed, but I think the adventure could be used in other post-holocaust games; certainly it can be used as an example of good plotting and thought. □



## Adventure For Champions

### THE CORIOLIS EFFECT

By Dennis Mallonee  
(Hero Games \$6)

Reviewed by Aaron Fichtelberg

*THE CORIOLIS Effect* is the fifth adventure for Hero Games's popular superhero role-playing game *Champions*. In this adventure, Doctor Clinton Avery, a well known and mysterious professor of parapsychology has been asked to study a mysterious scroll found in Turkey. A scroll with the ability to bind human beings to the elements. The scroll has attracted the attention of the evil Black Enchantress, who wants the scroll, but also knows the professor's guarded secret. There is much more to the adventure, but in order to keep the scenario fun, I will not reveal any of the adventure's secrets.

Although the adventure has an interesting plot, the adventure is so poorly laid out and written that it is very difficult to run. Often times, the writer fails to note what would happen if the heroes are able to do the unexpected. This leaves the poor gamemaster in a hole, forcing him to play it by ear as to what happens; not a sign of a well thought-out adventure.

The adventure is set up as a series of short adventures. Totaling from three to four, depending on the players' actions and what the gamemaster would like to run. The adventures were not built to be run in consecutive order, but to be run as a continuing sub plot, with each scenario leading into the next. This type of adventure can be interesting to run but could prove difficult in a non-campaigning setting.

In several places, the villains to be used are left completely to the gamemaster. This is fine, if the gamemaster has the time and ability to prepare the forces of evil. But to many gamemasters,



this may be a difficult and tiresome chore, limiting the chance of the adventure to be run on the spur of the moment. The writer should have provided a list of recommended villains.

Another problem with the adventure is its lack of balance and realism in the gamemaster-characters and villains. No characters in the adventure have damage resistance, not even the earth elementals that are included. This could turn the scenario into a

blood bath, causing almost every character with a killing attack to be overpowering and allow them to dominate the adventure. The second problem with the elemental characters is that all of them have Damage Reduction (see *Champions III*), an overeffective power in this instance, and may unbalance the scenario for a team that uses all normal attacks.

Many of the actual characters (not including the elementals), have Magic Power Pools (again, see *Champions III*), a power which is difficult to be used by a gamemaster because of its diversity and complexity. But, along with the power's complexity, its effectiveness can cause an innocent gamemaster to fall to the dread "kill 'em all" syndrome, which is no fun for anybody.

Along with the characters necessary for the adventure, several extra characters slightly related to the adventure are included. They are nice to have around just in case, but are hardly necessary for the adventure. I would rather have seen more detailing done on each of the scenarios filling up

this space rather than the characters which presently fill it.

The interior maps are a let down from the company's previous ones. Many of them are scaled using two meters per hex scale, but no hexes are shown on the maps—confusing. The writing on the maps is hand-written and in a few places hard to read. In some places, the writing is difficult to identify what it is indicating on the map.

All in all, this adventure is not worth buying unless the gamemaster is willing to spend a lot of time fixing it up, and is ready to fill in the many blank spaces in the adventure. I'd recommend you save your money for comic books rather than spend it on this let down.

One final note, one of the major secrets in the adventure is revealed in the *Champions* comic book (a 6-part mini series by Eclipse Comics). Why did Hero Games do this? Although the series isn't finished, I hope they come up with a good explanation for giving away the secret. □



## CTHULHU BY GASLIGHT

### Horror Roleplaying in 1890s England

By William A. Barton  
(Chaosium \$19.95)

Reviewed by Scott D. Aniolowski

SHERLOCK HOLMES vs. Cthulhu? Yes, now it is possible with Chaosium's *Cthulhu By Gaslight*. Now your investigators can meet such real-life and fictional characters as Sherlock Holmes, Moriarty, H.G. Wells, Aleister Crowley, Jack the Ripper, and Count Dracula; this supplement pack presents rules and additions to *Call Of Cthulhu* for use in the 1890s. Travel back to Victorian England with it's eerie fog and cobbled roads and explore the dark corners of

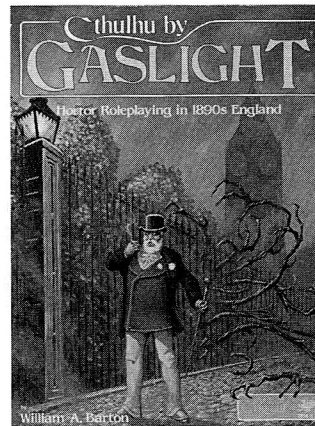

London at the turn of the century.

This supplement pack contains a 55-page Sourcebook for the 1890s, a lengthy scenario that pits the investigators against one of Sherlock Holmes's most dread nemesis and Mythos-related

machinations of insane cultists, a large map of London, and revised character sheets with appropriate new altered skills for the era.

The sourcebook gives new occupations, social classes, new/altered skills, weapons, a timeline of England from 1880 to 1901, several interesting biographies, locations in London, notes on travel, crime, government, royalty, the occult in the 1890s, prices and coins in use, and a ten-page section on various types of time travel and the consequences and uses thereof. Also included in this book is a Sherlock Holmes timeline and a few new monsters for the game taken from the inspirational works of H.G. Wells.

Most of the new occupations are basically derived from those in the *COC* Rulebook and Sourcebook from the 1920s and include such things as adventuress, clergyman, and consulting detective.

Altered skills include Pilot Aircraft, which, in this game is Pilot Balloon. The biographies consist of explorers, writers, politicians, and actors, most of which should be familiar to most players (Bram Stoker, Gilbert and Sullivan, Oscar Wilde, etc.).

The list of locations contain both familiar and not-so-familiar places and a quick glance through the list is sure to create many a devious scenario in the twisted mind of the Keeper. The map, which clearly marks railways and the underground, should prove an immense help to those of us in the colonies who are less than familiar with London.

The author has obviously spent a great deal of time in the research of this supplement—a

quick glance just at the list of coins in circulation and their worth will prove this. Just flipping through the pages of the sourcebook brings to mind cold gloomy nights, echoing footsteps on damp stone roads and the booming ring of Big Ben. Fans of Victorian England, gothic novels, and Sherlock Holmes should appreciate this one.

The lengthy section on time travel is most interesting and includes travel through gates, machines, and psionically. Many a world could be thrown asunder by careless acts of time-traveling investigators, and the author warns Keepers against allowing such free-spirited jaunts through time. This particular problem, however, brings to mind many

very interesting and devious scenario ideas involving time-meddling and history-changing and any good Keeper worth his salt should be able to take full advantage of such ideas.

The incursion of H.G. Wells's Morlocks and Martians (and those nifty War Machines) is a very nice touch and this Keeper wouldn't mind seeing more additions of different writers' monstrous creations into the Cthulhu Mythos so long as it does not become too watered-down and cluttered with junk, and as long as the critters fit well. Anyway, it is nice and investigators might be lucky enough to be a part of the Martian invasion as it happened in *War of the Worlds!*

*Cthulhu By Gaslight* is not a

necessity to players of *Call Of Cthulhu*, and the era seems a bit limited to this writer, however *Gaslight* does have many useful and entertaining things to offer and adventuring in Victorian London is a nice, fun change of pace from the 1920s. If you are a Sherlock Holmes fan, which the author most obviously is, this is a must for you.

One final thing—the cover of the box. The cover splendidly depicts a proper English gentleman complete with derby and walking stick being menaced by twisted, tentacle-like branches through the bars of a high fence, Big Ben off in the grey, gloomy background. Sanity roll for that poor bloke! □



## Teenage Mutant Ninja Turtles Supplements

### AFTER THE BOMB ADVENTURES!

Both by Erick Wujcik (Palladium \$6.95 each)

Reviewed by Scott Dollinger

IT IS the 21st century and the war that could never happen did, with a vengeance. Man unleashed a nuclear and chemical holocaust that was followed by a long nuclear winter. The result was an almost total destruction of civilization as we know it, but there were survivors. From out of the ashes of the past rise the founders of the future. . . . They're wierd . . . they're different . . . they're—funny animals? That's right, funny animals. Well, what did you expect from the first *Teenage Mutant Ninja Turtles* supplement entitled *After The Bomb*?

The overall stage for the adventures contained in *After The Bomb* is the now greatly changed northeast coast of the United States. The survivors of the holocaust, both human and non-human, have mutated from their exposure to radioactive and chemical agents and have subsequently gained new abilities.

In the human case, a very few of the survivors have gained psionics or other super-human powers the like of which can be found in the *Turtles's* compatible sister game, *Heroes Unlimited*.

The animal mutations have gained intelligence and a more humanoid body type as well as other powers straight out of *Teenage Mutant Ninja Turtles*. They also have the advantage of vastly outnumbering humans. This new dominance of sentient

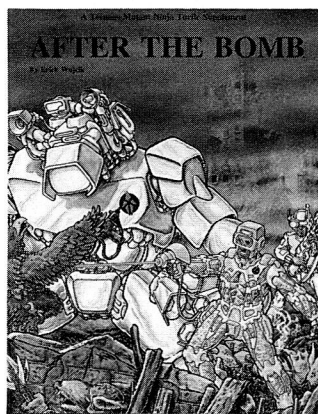

civilization by mutated animals has led to a somewhat polarized view concerning the proper inter-actonal relationships between humans and mutated animals. These differing views are represented politically in *After The Bomb* by the introduction of competing nations while representing each of the three dominant views.

The Empire is a technologically advanced human-based autocracy that holds, as its official position, that all mutated animals are an abomination and that they should be eradicated or enslaved by humans.

The Empire is surrounded by numerous loosely-led or anachronistic groups of mutant animals that are either run on the principle of everyone out for themselves or that humans are the source of all evil. Most of these smaller "nations" have little real power because they are not sufficiently organized to threaten the technological might of the Empire.

The Empire's biggest threat is from the egalitarian democracy of Cardania. Cardania is based upon the constitutional principles of the United States and in fact has

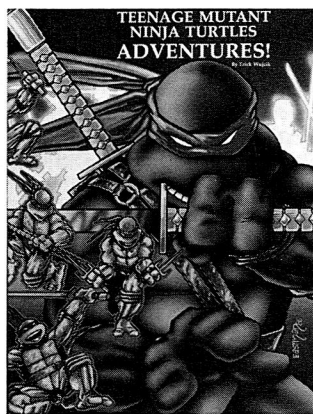

the same constitution. Cardania is comprised of both humans and mutant animals both of whom enjoy the right of full citizenship.

Cardania enjoys a technological superiority only slightly below that of the Empire and because of the value placed on universal education regardless of species, if given time Cardania will match and surpass the Empire. It is strongly implied that the only way for civilization to be truly reborn is to adopt the spirit of inter-species cooperation embraced by Cardania.

There are six pregenerated adventures in *After The Bomb*, five of which have the players working directly for the government of Cardania. The adventures are written to provide game-masters with the basic premise, a few planned encounters, and the stats on all important game-master-characters. They lack detailed maps and building plans and may require more advanced preparation for those game-masters who are not that adept at playing off the cuff. Do not be mistaken, however, all the really important information concerning the adventure is provided. The designer merely sacrificed unne-

cessary detail in order to fit more adventures into the supplement. The players benefit more from this in the long run. All the adventures in *After The Bomb* are particularly well balanced between action, problem solving, and light hearted fun and the post-apocalyptic world introduced serves as a great source for new adventure ideas.

The second *Turtles* supplement, *Adventures!*, has the same presentational format where basic premises, encounters, and character stats are presented and superfluous maps and details are omitted.

The setting and general tone of the scenarios are changed in *Adventures!* to be more in keeping with a superhero-type campaign. An additional difference is that the scenarios in *Adventures!* are designed primarily for use with the Teenage Mutant Ninja Turtles as characters. Other mutant animal ninjas or superheroes from *Heroes Unlimited* may also be played.

There are four independent scenarios in which players confront a group of terrorist bears bent on nuclear destruction, an inept cyborg, a troubled mutant youth, and a corporate takeover attempt by a mad scientist.

There is also a more complex fifth adventure where the characters engage an international ninja drug cartel in a contest to the death. The scenarios as a whole in *Adventures!* are much more dangerous than in *After The Bomb* and only somewhat experienced players should try the contest between the two ninja clans.

Both *After The Bomb* and *Adventures!* are well written, easily run, and humorous. Both feature original art by Eastman and Laird, and both are an exceptional value for the price. □



## HIGH SEAS

By Mark Pettigrew (FGU \$6)

Reviewed by Sean Holland

*HIGH SEAS* is an expansion for *Flashing Blades* (reviewed in *DW 43*) that allows for adventures in the New World and at sea.

The first part of the *High Seas* book contains rules for generating a New World character. The New World characters can have one of the following six backgrounds: colonial rogue, colonial gentleman, colonial soldier, marine, sailor, or pirate. It is possible to play Old Worlds characters, generated using *Flashing Blades*, as well. New skills, both martial and otherwise, are added and changes to the advantages and secret rules are made for the New World.

The personal combat section covers new weapons, rules for fighting on board ship, fighting in the rigging, swimming, and drowning are introduced. These rules are simple, yet they give the right feel for swashbuckling melees aboard ship.

The next section, ranks and position, starts with a short introduction to the French Colonies in the New World. The social order of the New World was slightly different from the Old and a list

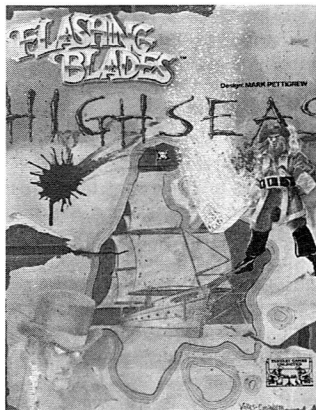

of new social ranks is included. This section of rules, like the section of the same name in *Flashing Blades*, is very flexible. It could be applied to other games as well, as it is one of the better systems of social ranks that I have seen.

The next rules section is about pirates and privateers. These rules cover pirate Articles (the laws of a pirate ship). Letters of Marque, pirate and privateer expeditions, and booty.

One of the most interesting and unique sections of the pirate rules is the Ruthlessness rating. Ruthlessness ranges from 1 to 20 and it is gained by capturing ships, plundering towns, and killing the

captains of enemy ships in single combat. As the captain's Ruthlessness rating climbs, it increases the morale of his crew, improves his chance of recruiting men, and he can even make merchantmen surrender without a fight by hoisting his Jolly Roger. Most pirate ships were run by a sort of democracy but when a captain's Ruthlessness rating climbs above 10 he can attempt to seize total control of the ship.

At a Ruthlessness rating of 10, a captain may indulge his vanity by adding a short title to his name (i.e., Albert the Awful, Raoul the Ruthless, Diego the Dreadful, etc.). With a Ruthlessness rating of 14 the captain may add a noble title to his name. This fanciful title will not be recognized outside pirate society.

The dangers of fame are evident since for every point of Ruthlessness, the character will have one warship out looking for him. Well, a pirate's life is not all parrots and plunder.

The pirates and privateer rules are well written and comprehensive. They could be useful for any game using pirates.

The last section of the rules covers ship building, trade, and combat. The ship building rules are complete and well written, allowing for a variety of ships,

cargo, and weapons. Trade and travel is simply covered along with a system for encounters at sea. The ship-to-ship combat system is quick and easy and it contains an equally quick system for resolving boarding actions.

Included in *High Seas* is a mini-campaign of four adventures. The first of these is "Scavenger's Daughter," where the characters are sent to the New World to deliver a message, but are instead captured by pirates and forced to join the crew. In the second adventure, "Pike's Trove," the characters attempt to find the buried treasure of the infamous pirate Red Pike. The third adventure, "Guede-Je-Rouge," revolves around the attempt to break a voodoo curse that has been placed on the daughter of the Colonial Governor of Tortuga. The last adventure is "Portobelo" in which the characters are sent into the Spanish city to ferret out the routes of the mule train carrying Spanish treasure.

I am quite impressed with *High Seas* as the author has managed to put so much useful information in such an inexpensive book. So if you play *Flashing Blades*, and you wish to expand your game, hoist the Jolly Roger and buy *High Seas*. □



Approved for use with Traveller

## LEE'S GUIDE TO INTERSTELLAR ADVENTURE VOLUME 1

By Gregory Lee (Gamelords \$5.95)

Reviewed by Tony Watson

IN THIS *Traveller* playaid from Gamelords, designer Gregory Lee has taken a new tact in the approach to scenarios for the popular science-fiction role-playing game. Rather than the thoroughly-scripted, detailed, and carefully-plotted situation players have become accustomed to from GDW's line of adventures, the *Guide* offers outlines and ideas to be fleshed out by the referee.

There seems to be a healthy respect for the imaginative powers of the *Traveller* referee, and that's a feature that all *Traveller* referees should be appreciative of.

*Lee's Guide to Interstellar Adventure* is organized to provide eleven different settings for adventure. Ten are planets, while the last is an outline for adventure along the Imperial x-boat routes. In each of the entries, a description of the world is given, follow-

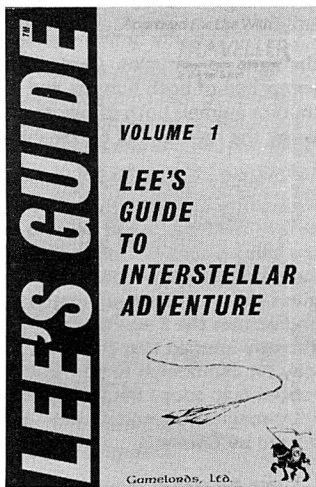

ed by some ideas for situations, outlines for action and suggestions for handling them.

A universal planetary profile is listed for each planet; Lee also lists a range of UPP-code ratings that will be acceptable for that planet should one not exactly corresponding to the given UPP exist on the referee's map. Campaigns set in GDW's Spinward Marches or Solomani Rim can easily take advantage of these adventures, since the designer has thoughtfully provided the names of worlds within these subsectors that are appropriate settings. This

will save referees who use these GDW-designed subsectors a considerable amount of time when deciding where to implement these scenarios.

An example of the approach taken in the *Guide* is scenario two, "Thirst," set on a non-industrial, desert planet. A couple of paragraphs explain the political and economic situation on the world. The megacorporation Hortalez et Cie has previously worked out an agreement with a confederation of the small trade towns that dot the planet; the corporation provided the capital to create large water processing plants that extract water from the ferrous-oxide soil of the planet. In exchange, the town turns over the by-product of the water collection process, iron. The megacorporation maintains a large presence on the planet, occupying Supreme Council seats and working closely with high-level local politicians to keep a lock on the high-tech expertise needed to run the plants.

The players can come into the scenario in several ways. A lure, in the form of a rumor of a new anagathic discovered by the world's nomadic tribesmen can be used to bring a character group that serves as a free-trader crew; military types might be sent to the planet

as Hortalez et Cie mercenaries; or, players skilled in bribery or administration may arrive as agents of a rival company. The scenario makes it relatively easy for characters of any type to be smoothly integrated into the action.

Upon arriving on the world, the players will be thrust into the middle of a crisis caused by damaging of the main water processing plant by an object falling from space at meteoric speeds. How the characters will fit in will depend on their skills. Those with technical skills may be pressed into service repairing the water plant or increasing production from the functioning plant. Players with military experience may be drafted for security or anti-riot duties, while ships' crews may be placed on patrol or utilized for water smuggling.

The outline concludes with some possible ideas for complications. Most important of these is who, if anyone, is behind the meteorite's fall: several possibilities and their implications are offered. These complications can lead to further phases in the adventure, depending on how the referee chooses to handle them.

The above scenario is lacking in many of the aspects that are common to the prepared adven-

tures offered for use with *Traveler*. There are no maps nor diagrams; listings of referee-characters and reaction tables are nowhere to be found, as are the often superfluous player-character stats and equipment lists. What's left is an interesting outline for adventure that can be molded to the needs of the referee and his playing group. The details are left up to the referee, making it easier to fit the situation into the flow of an ongoing campaign.

What's especially nice about the

*Guide* is the fact that there are eleven such scenarios. For example, scenario four, "After the Gold Rush," is set in a mined-out asteroid belt that has been renovated as a resort; possibilities for crime, smuggling, or security work present themselves against a backdrop of a terrorist attack or the discovery of a heretofore undetected lode. Scenario seven takes place on a penal planet, while nine, "Troubled Waters," is set on a water world, where a race of humanoid amphibians is

engaged in a guerilla war against human colonists. Options for the colonists are listed, and the scenario is set up in such a way as to give the players a chance to choose the side of the natives. Other situations in the book include a scavenger hunt on a planet used for Imperial military training, and being thrust into the middle of a war on a balkanized world of 20th-century technology. With few exceptions, the scenarios are interesting and imaginative.

I was pleased with volume 1 of *Lee's Guide to Interstellar Adventure*, and look forward to subsequent volumes, should Gamelords decide to produce them. The looser, less detailed and choreographed scenarios leave room for the referee's imagination to flesh out the details and mold the story to conform to an on-going campaign. *Lee's Guide* is so filled with good ideas for the referee that likes to handle the details himself, that it is good for many sessions of challenging role-playing. □



## THE BOOK OF TREASURE MAPS

By Paul Jaquays  
(Judges Guild \$3.95)

Reviewed by Jonathan Tweet

*THE BOOK of Treasure Maps* is a 50-page book with five adventures designed for the original *Dungeons & Dragons* rules and set in the Judges Guild world. This set-up poses a problem because few people still play the original *Dungeons & Dragons* and few gamemasters run the Judges Guild campaign. Nevertheless, an imaginative gamemaster can use the maps, settings, and ideas in the book for his or her own game and campaign.

The five scenarios vary in length and complexity, though all are short. They are designed for powerful parties, those capable of facing a vampire, a mummy, and demons, and whose bank accounts would not be overloaded by gems worth thousands of gold pieces each. What the adventures have in common is that characters are directed to the adventure sites by maps of some sort. Each adventure includes a facsimile of the map that the adventurers find. The gamemaster photocopies these maps and gives them to the players, increasing the realism of the adventure. In addition to the maps, each adventure provides ways for the characters to find information about the adventure sites before entering them, such as rumor-gathering and library research. The maps and the information prime the party for the adventure, making it more enjoyable.

The first adventure is a raid on an abandoned evil temple. If the party can handle the demon involved, they win an appropriately sizable treasure. The second adventure is looting the tomb of a lord whose dealings with undead have left an unhealthy legacy. Traps, undead, and strange family members abound. The third scenario is larger and more intricate, with a small, magical castle in-

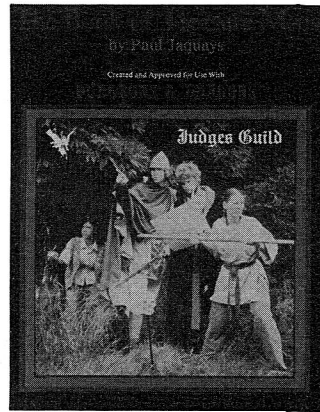

habited by an array of interesting, intelligent monsters. A lot happens in this adventure, and it should keep the players guessing. The fourth adventure is straightforward and high-powered. Players face a demon lord and can win treasure worth over a million gold pieces if they are lucky. The final adventure has a novel format. The adventurers explore underground catacombs that are crawling with undead. Eventually they can reach a slew of treasure, but a seemingly endless supply of undead is attracted to them. And the longer they stay underground, the more undead come their way.

While none of the adventures are fascinating, all are interesting and show imagination. Each contains a new monster or monsters from the author's imagination, and all present interesting visual images that one might expect from an artist, such as Paul Jaquays.

But even though the adventures are attractive, the question remains whether anyone would be able to use them, or at least anyone who doesn't run a Judges Guild, original *Dungeons & Dragons* campaign. I think the adventures are usable, though they may require some work. Before buying the game, a gamemaster must consider how much work it would take to adapt the adventures to his or her campaign and how much work he or she is willing to do.

Unfortunately, three of the

maps that make these adventures so interesting refer to other geographic areas than the adventure site themselves, locations that would not be found in most campaigns. A gamemaster cannot photocopy and use the maps without bringing some of the Judges Guild campaign into his or her own. Since most of the action, however, takes place at the sites themselves, and these really could be placed just about anywhere, most fantasy worlds would be able to incorporate these adventures.

If the adventures are used for *AD&D*, they will fit well into the rules system. The gamemaster might want to correct some of the stats to follow changes from the original rules to the advanced, such as revising hit dice of the monsters, but these changes are not necessary.

These adventures could even be used in any of several other fantasy games. The rumors, maps, and concepts generally fit most fantasy settings. Also, most gamers are familiar with the game rules used, and that makes conversion to another system easier. Gamemasters who know what armor class and hit points are in *Dungeons & Dragons* would be able to find equivalents in what-

ever systems they are using. The adventures also present generic enough monsters that they could be found in most other games. Vampires, animated skeletons, and wolves, whose *D&D* incarnations inhabit these adventures, are often found in other games as well. In this case, the adventures would provide descriptions and ideas, but the gamemaster would still need to do much work in determining details. This work, however, would assure the gamemaster that the adventures would fit his or her needs and the needs of the adventuring party, an advantage that a gamemaster using the adventures as they are would not have. By being based in a game system as well known as *Dungeons & Dragons*, these adventures almost become a universal playaid.

*The Book of Treasure Maps*, then, is an imaginative piece of work at a low price. The determinant of the book's value to a gamemaster is how well the adventures' settings and rules would fit into the gamemaster's own campaign and how much work he or she is willing to do in adapting what is provided. If you have a compatible campaign, imagination, and a little free time, I recommend this book. □



## Marvel Super Heroes Official Game Adventure THE BREEDER BOMBS

By Jeff Grubb (TSR \$6)

Reviewed by Larry DiTillio

*THE BREEDER Bombs* is TSR's first module for their *Marvel Super Heroes* game (not counting the one which comes with the game set). Its feature attraction is the X-Men, a group that has always proven solid gold for Marvel Comics. Judging by the overall quality of this product, it should provide some gold for TSR as well.

The X-Men of *The Breeder Bombs* are Colossus, Night-

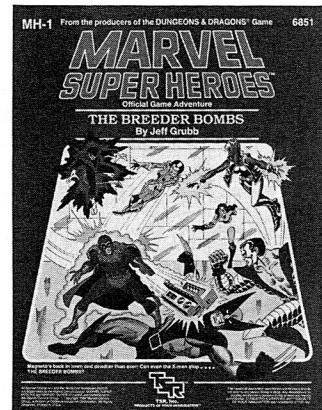

crawler, Rogue, Storm, Ariel, and Wolverine. The scenario is designed for all of them and if you can't come up with six players I'd still



suggest using all, either by having players use more than one hero or by running them as gamemaster-characters. *The Breeder Bombs* can be tough and less than a full contingent will find players at a distinct disadvantage in the later stages of the scenario.

The package consists of a 16-page scenario booklet, a colorful map (one side of which depicts the X-Men Mansion, the other side showing a wilderness area), and a light cardstock folder enclosing booklet and map and bearing the stats and descriptions of the X-Men, Lockheed (Kitty Pryde's pet dragon), and the X-Men's plane—the Lockheed RS 150 *Blackbird*. The fact that the X-Men stats are on the folder is somewhat annoying. A gamemaster will either have to photocopy it or cut it up to give the players their character cards. Wolverine is not stated as his card appears in the basic game set. The booklet itself contains the seven chapters of the scenario, stats for Magneto, Professor X, and the other villains of the piece, and a rather dull black & white map of Magneto's lair. This map constitutes yet another annoyance. It's supposed to be used when the X-Men enter Magneto's lair but since it appears on the last page of the booklet, the gamemaster must again either photocopy it or trash the booklet to use it. It would have made much more sense to simply put the map on a separate piece of paper. Fans who have the Marvel role-playing game set may be a little disappointed that the color-

ful and durable cards representing the heroes and the counters used for movement do not exist in the module, giving the game a graphic inconsistency that rankles.

*The Breeder Bombs* begins with a session in the famous X-Men Danger Room which may or may not escalate into something more than a mere test of abilities depending on what happens "off-stage." Each X-Man has a special device to battle, at the outset, but they need not stick to these. Needless to say, a villain does arrive in Chapter One to lead the X-Men onto greater things. This villain is the Fixer and he is there basically to be captured, something which should prove about as difficult as swatting a flea with an howitzer. The Fixer's capture brings the X-Men to an abandoned cannery to check out the supposed murder of the villain Mentallo by Wolverine. This is one of the nicest bits in the scenario and a good excuse for making sure that Wolverine is being played in the scenario (designer Jeff Grubb suggests that another X-Man may be put on the spot for the crime, but Marvel fans will appreciate that Wolverine alone might be considered guilty even by his own teammates).

Once the X-Men check out the cannery, they pop off for a brief interlude during which Professor X puts them on the trail of the real meat of the scenario—the Breeder Bombs. Breeder Bombs are not really bombs but open-air

nuclear reactors which spew radiation into the upper atmosphere. There are four of them altogether and if allowed to remain unmo-lestled they'll eventually kill millions. The apparent master-mind behind the plot is the X-Men's nemesis Magneto.

From this point on, *The Breeder Bombs* becomes a fast-moving race to save the world as Professor X locates each bomb and sends his X-Men off to deal with them. Along the way, they must face a variety of Marvel villains (I won't say who, I don't want to spoil anyone's surprise) and some very nicely-conceived plot twists that provide excellent opportunities for non-combat role-play. The climax is interesting and if played close-to-the-cuff should give the players a surprise or two.

On the whole *The Breeder Bombs* is a lot like playing out an X-Men Annual, jumping from spot to spot, fighting off sundry villains to save the world, and going through the mutant brand of interactive drama. There are minor trouble spots; the first two chapters are overly contrived to get the X-Men into action (is there any mighty Marvelite out there who believes that the Fixer would attack X-Men Mansion single-handedly just to avenge Mentallo?) and the clues presented in the Interlude in Chapter Three are a bit too subtle and arguable at that (they work on the character of Magneto, however there are other conclusions possible than those which the designer supplies for the evidence

seen). A definite no-prize glitch crops up in Chapter Two when the scenario tells us that Wolverine may recognize Mentallo's scent on something, shortly after we've been told that Wolverine has never met Mentallo (which would make it kind of tough for him to recognize his scent). Like I said, these are minor problems, but they're still annoying in an otherwise peachy scenario.

Possibly the best thing about *The Breeder Bombs* is the way it espouses and captures the X-Men flavor. There is opportunity for inter-team conflict, there is Professor X playing the omnipresent background general, there is lots of human paranoia toward our heroes, and even if they succeed in saving mankind, mankind won't give them an iota of credit for it (indeed they are more likely to be arrested in some country or another). In a game like *Marvel Super Heroes* where characters are so familiar, this type of flavor is essential and Jeff Grubb handles it well. An added plus to the scenario's value is the X-Men Mansion/Wilderness map which is eminently useful for gamemaster-created scenarios and nicely augments the basic game maps. By the way, art in *The Breeder Bombs* is by Marvel's own Sal Buscema and is tasty if not overwhelming. At its price *The Breeder Bombs* is a good buy and if you're into *Marvel Super Heroes* and like the X-Men (is there anyone who doesn't?) you should enjoy it. □

## BOOKS

Continued from page 45

threatening the independence of the amazon state. In the course of it he must grow to adulthood and wisdom, as must his counterpart in the enemy nomads, also driven into exile by treachery in his own people. Between them is the daughter of the queen of Sabazel, who must also find statehood in

the manner of the goddess and who learns to love both men. Over the years, she bears a child of each, one of whom is heir to Sabazel. It seems a safe bet that the third novel, *Shadow Dancers*, will be the story of that heir.

What makes these books instructive to gamers is the lessons they teach on the clash of cultures. We can learn how to give a character

a different view of life by watching how the children of these cultures rub against each other and end up going in directions very different from what would be the expected result in our own world.

As a literary question, what interested me the most was how the author handles the battle of

the sexes. Each of these novels is the story of young people learning their early lessons about the other sex, in the course of dealing with the chaos of war. What she has to say is well worth reading, and I'm looking forward to the next generation. □

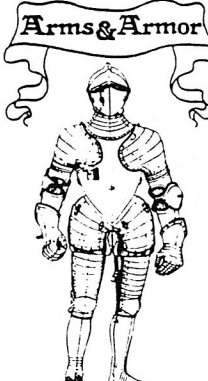

**Arms & Armor**

ARMS & ARMOR, Medieval & Renaissance replicas of museum quality. Stock items are well researched. We specialize in custom work done to order. Edged weapons & armor from 5000 B.C. to 1700 A.D.  
Send .50¢ for catalog.

Arms & Armor  
420 5th St. N.  
Minneapolis, MN  
55401

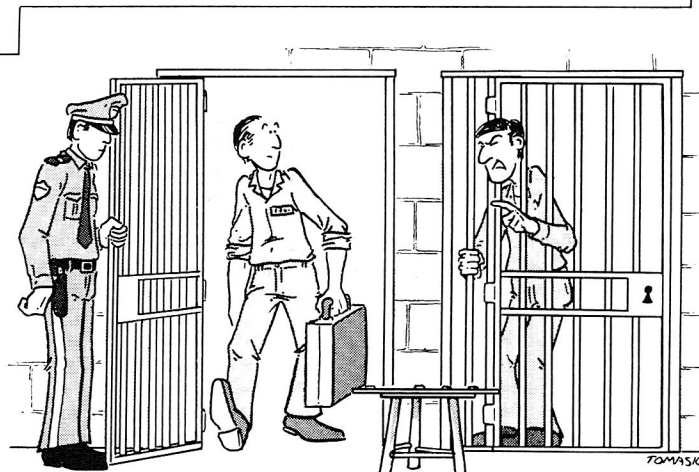

"PAROLE NOTHIN! YOU GET RIGHT BACK IN THERE TILL WE FINISH THIS GAME!!"

# SPACEGAMER

## FantasyGamer

# IS BACK



Space Gamer / Fantasy Gamer magazine is returning well in time for Christmas, and with so much to herald, we want to make sure you get the right gift! Space Gamer magazine has been published for eleven years, and has served Science-Fiction and Fantasy gaming fans faithfully through the years. It is a magazine with a long history, an outstanding reputation, and now it's having a glorious rebirth.

**The new Space Gamer / Fantasy Gamer** magazine will be appearing in stores and mailboxes throughout the land by December. Issue number 77 will mark a new era of creativity for one of the longest-published magazines in the hobby.

The new Editor is Anne Jaffe, formerly of Game News magazine. Anne is not only one of the industry's most qualified (and esteemed) editors, she is also energetic, organized, devoted, punctual, and has a great eye for the details that make all of the difference in a quality magazine product.

The new Art Director is Vince DeNardo, currently Art Director for both Fire & Movement and Computer Gaming World magazines. Vince is giving Space Gamer / Fantasy Gamer a new look, dynamically improved over previous issues, and an advance for all magazines of this genre.

**Even the publisher is giving you more with the new Space Gamer / Fantasy Gamer.** An increase in size from 48 to 64 pages (while still keeping the current cover price) is one heck of a fine gesture. They're not stopping there, however, because this notice also includes the following new subscriber deal:

**Bundles of FREE issues with your paid subscription!**

That's right, get a 3-issue trial subscription for only \$9.50 and pick out any bundle of back issues, or try a 6-issue one year subscription for only \$18.00 and pick out any **two** bundles of back issues, or get a full 12-issue two year subscription for only \$35.00 and pick out any **three** bundles of back issues.

Please include an additional \$3.50 for one, \$5.50 for two, or \$7.00 for three bundles of back issues to pay for shipping and handling; Canadian addresses please add an additional \$1.25 per bundle; overseas an additional \$2.00 per bundle.

Please specify which bundles of back issues you want. Each contains from five to thirteen issues of Space Gamer and Fantasy Gamer magazines grouped together by the common theme of the major articles in them. Bundles may also be purchased separately for only \$6.00 each (postage paid in the US, Canada add \$1.25 per bundle, overseas add \$2.00 per bundle).

BUNDLE A: AD&D/D&D #1  
BUNDLE B: AD&D/D&D #2  
BUNDLE C: Traveller #1  
BUNDLE D: Traveller #2  
BUNDLE E: Ogre/G.E.V. #1  
BUNDLE F: Ogre/G.E.V. #2  
BUNDLE G: Car Wars/Killer  
BUNDLE H: Play-by-Mail  
BUNDLE I: Complete games in every issue  
BUNDLE J: Everything else #1  
BUNDLE K: Everything else #2

**The best fantasy and science-fiction reading awaits you in issue after issue of Space Gamer / Fantasy Gamer magazine. Join the adventure today!**

All payments must be in US funds and drawn on a US bank. Make all checks payable to DTI, P.O. Box 8399, Long Beach, CA 90808.

ENCLOSED IS MY \$ \_\_\_\_\_. I AM SUBSCRIBING TO THE NEW SPACE GAMER / FANTASY GAMER FOR \_\_\_\_\_ ISSUES. PLEASE SEND ME THE BUNDLES OF BACK ISSUES I HAVE CIRCLED BELOW:

NAME \_\_\_\_\_

ADDRESS \_\_\_\_\_

CITY \_\_\_\_\_ STATE \_\_\_\_\_ ZIP \_\_\_\_\_

SEND  
BUNDLES    A    B    C    D    E    F    G    H    I    J    K

# DISEASE IN GLORANTHA

By Oliver Dickinson

IF YOU think about it, Gloranthan diseases are peculiar things (throughout, I shall be considering the diseases of *Cults Of Terror*, pp.30-32, as well as the five major diseases of *RuneQuest*; the *Terror* diseases are well worth keeping in *RQ3*, in my opinion). They simply do not behave the way our germ- and virus-spread diseases do. For a start, all so far reported are contagious (which means a disease passed on by contact, contrary to what is implied in *Big Rubble* Gamemaster's Guide, p. 26; infectious diseases are those carried by droplets in the air). Most of them have very serious effects, only reversible by magic or great skill in treatment; yet generally they can be brought to a halt simply by bed-rest, with reasonable luck and an average level of CON. Indeed, exceptional luck can cure them in unfavorable circumstances; the horse of a character of mine threw off serious Wasting Disease by a CONx1% roll while carrying her home. How nice it would be to be able to stop a cold or 'flu like that! But apart from Sniffles there are no diseases like these tediously recurrent but normally harmless afflictions of our world; there is not even an equivalent for the diarrhea which so often afflicts travelers, though there certainly ought to be in an ancient-style so probably very unhygienic culture.

But I do not intend to propose a new system of Gloranthan diseases. Let us simply accept that this is the Way Things Are, and consider some interesting (to me) points that arise and are not really covered in the rules.

[1] There is a potential anomaly in the rules governing rest as now presented (*RQ3* Player's Book, p. 82). If rest must be taken all the time to allow the next CON-roll attempt to throw off the disease to be a full CONx5%, this would require a full week's bed-rest for the mildest form, but much less for the more serious stages. In *RQ2*, p. 106, rest was not required to resist the mildest ("chronic") form at full strength, and I certainly think this would be more reasonable. But I would stipulate that serious wounds, or continued exertion in any form, should affect the chances of recovery even from mild disease; a character should take it easy, but not be required to retire to bed for a full week.

[2] How can the information that a character has caught one of the five

major diseases be conveyed realistically? (I know the character must make CON rolls; this still does not inform of the nature of the disease, and I am sure many gamemasters and players would like to role-play in this as in other areas.) *Terror's* "minor" diseases have detectable and continuous symptoms, but a sudden feeling of weakness, dullness, clumsiness, etc., though it might make one suspicious, could well be shrugged off, since few people want to believe that they are ill; and since disease can be caught from an infected source, it can strike when a character will not be alert to the possibility, as one would be in the neighborhood of broos, for instance. So what symptoms should the major diseases have? The names Shakes and Chills suggest the appropriate symptoms, a continuous headache might suit Brain Fever, and a continuous feeling of tiredness or weakness for Wasting Disease; but how to suggest Soul Waste? This brings up other fascinating questions, such as how Gloranthans know how much POW they have and how they can wield it in measurable amounts of Magic Points, but let's not get into that now (I suspect the God Learners come into the answer somewhere). I have no answer, unless one could feel one's spirit draining away; it could well be suggested that perceptions relating to POW are a sixth sense that we lack.

Further, how can a Healer detect the presence of disease in water or on inanimate objects? Identify Disease, a skill taught by Arroin and Malia, makes no appearance in *Gods Of Glorantha*, but there is a strong case for it. *Terror*, p. 27, suggests that a Healer will know the "signs" of Malia, whether by this skill or some other, and it could well be one of the Previous Experience skills of a Healer.

[3] How likely are diseases to spread? I decided that the rider of the horse with Wasting Disease caught it immediately from her mount, but was I right?

Weapons that strike broos should become infected in the striking area, but will this spread to the whole item? If you have successfully resisted a disease which you have contacted, do you nevertheless become a carrier? I feel that the answer to the last is no, if only to make life easier for the poor gamemaster, but this will be another strange property of Gloranthan diseases. Infection should probably not spread on an object, but continual handling must sooner or later bring the object's owner into contact with the infected area, if it is not cleansed; the gamemaster could make POW rolls for the character to see when this might happen. It is worth remembering that the infected area might well be large, if broo blood, sweat, or some other fluid has showered the weapon, and that a person can be exposed to disease in this way without actually touching the broo (as with the Chaotic Feature of Exploding, which may expose all in a 3-meter range to infection). To make matters worse, a shield or piece of armor struck by an infected broo weapon ought itself to become infected in the area struck. On the question of speed of spread of a disease, perhaps one should allow a certain amount of time, if only a few melee rounds, before a rider can catch disease from a mount, but this is not forced; Gloranthan diseases do seem to take hold very rapidly.

[4] Broos have such nasty habits that one ought to be exposed to something even if they are not carriers of a particular identified disease. In our world, contact with water infected with human wastes can cause anything up to hepatitis (jaundice), if it is ingested or let in through a scratch or cut; as I know from experience, this is a real bastard, putting you on your back for 6-8 weeks on a restricted diet, followed after recovery by no alcohol for a year. If we are kind and ignore this, at least it could be suggested that contact

with any otherwise uninfected brood or its blood, etc., or any of its possessions giving a 50% chance of catching the Screaming Squitters (alias Delhi Belly, Montezuma's Revenge, etc., in the world). CON rolls as usual, and game-masters can use their imaginations on symptoms; I would suggest that, in mild form, the urge should be at least temporarily controllable.

[5] Overall, the tendencies of this discussion are to suggest that chances of infection are very high, for a character's possessions if not person, when broods or similar disease-carrying creatures are encountered. If so, it seems only fair to provide a shorter and easier method of trying to cleanse items than that described in *Big Rubble* Gamemaster's Book, p. 26. Storm Bull cultists and Praxian nomads, two groups who are likely to encounter broods with some frequency, are not going to like being parted from their favorite weapons, shields, and items of armor longer than is absolutely necessary, and so should have developed methods which may not be one-hundred percent effect, but give a reasonable chance of success.

Diligent researches in the Lhankor Mhy archives in Pavis have produced an account of a ritual used in some

part of Prax and the Vulture Wastes, which involves calling on the power of the elements, water, earth, fire or light, and air or wind. This is a Ceremony ritual requiring 1 Magic Point from each participant, but taking 1 hour in its basic form, though shamans may know, and teach their apprentices and others, the more elaborate version which takes 4 hours, one for each element, and thus adds 3D6 to the chance of success, which is as for a Spirit Magic spell cast by the leader of the ritual, who should be the person with highest POW. Some portion of each element must be used; if no pure water is available or if there is no source of light (e.g., at night) or means of making fire, deduct a quarter of the time taken and of the chance of success.

In a variant form of this ritual, Storm Bull cultists will call on the power of their god alone, taking a maximum of 3 hours, and it is highly likely that other cults with an elemental link, such as Orlanth and Yelm/Yelmialio, will have a similar preference. Trolls might well call on darkness as one of their elements, certainly never on air/wind or, unless Zorak Zorani, on fire. In all such cases, the extra hours will each add 1D6 to the chance of success. It seems eminently likely that the

Chalana Arroy cult has developed its own version of this Ceremony in areas of high disease potential such as Prax, calling on their god's healing power rather than on that of an element.

A much simpler method of using the power of an element would be to wash an infected item in pure water, expose it to fire, or plunge it into the earth for a certain period, but these would have the risk of contaminating the earth or water, while fire might damage the item. Nevertheless, I suspect some might wish to try fire on well-forged weapons, which should not easily take damage. I feel that this should be considered a more chancy method, success to be governed by a Luck roll of at most POWx3%; game-masters might think POWx2% or even as a percentage more appropriate, depending on the degree of contamination.

[6] It remains to suggest that perhaps the gamemaster, rather than the player, should make CON rolls in the initial stage of determining whether a disease has been contracted, thus keeping the player in the dark; but this might be difficult to conceal. I am sure that the ingenious will find more to say on this topic, but these are the problems that I have experienced over the years. □

Your own **Full Figure CHARACTER**  
 Rendered by Professional Illustrators - 8 1/2 x 11  
 ROLE PLAYING SUPER HERO SCIENCE FICTION FANTASY  
**FREE** character description sheet (ENCLOSE 2 POSTAGE STAMPS)  
**ANVIL ENTERPRISES**  
 P.O. Box 4028  
 Indialantic, FL 32903

**ANVIL ART SERVICE**  
 Full color and black & white art for Games, Books, Individuals by **PROFESSIONAL ILLUSTRATORS**  
 Covers, role playing fantasy · super hero · science fiction characters, maps, diagrams, comics, manuscript layouts, company logos. Estimates available!!!  
 The Original **ANVIL ENTERPRISES** P.O. Box 4028 · Indialantic, Florida 32903

## NEW GAMES

Continued from page 43

**Airlords of the Ozarks** (GDW, 48pp, \$7) by William H. Keith, Jr. "The players must infiltrate and gather information on New America, a bizarre right-wing organization determined to build an empire from the ashes of the United States. Among the things they will discover will be Operation Eaglestrike, a plot involving salvaged cruise missiles."

### FOR WARHAMMER FANTASY ROLEPLAY

**The Enemy Within** (Games Workshop, folder, \$12) by Jim Bambray, et al. Contains a 23"x33" map, a 17"x12" map, a 56pp campaign and guidebook, and 8 pages of handouts. "... launches an epic campaign against the forces of Chaos. The pack concentrates attention on the mighty Empire and is a definitive guide to this part of the Warhammer Known World."

### FOR ANY SYSTEM

**Phoenix Command** (Leading Edge, boxed, \$18.95) by Barry Nakazono. Small arms combat system with data for over 140 modern weapons (all illustrated). Comes with a 48pp rulebook, a 26pp small arms weapon supplement, playaids, character sheets, and a 10-sided die.

**Halls Of Horror: Gothic Floor Plans** (Games Workshop, boxed, \$8). On 8"x11" cardstock: 12 sheets with 13 complete rooms, plus 2 sheets of furniture and accessories, including two cars, to set the scene in any period up to the present day. Compatible with Dungeon Floor Plans.

**Dungeon Rooms** (Games Workshop, boxed, \$8). Twelve 8"x11" cardstock sheets with 23 dungeon rooms (torture chamber, necromancer's study, armory, mausoleum, orc's den, etc.) and lengths of corridors.

**Beyond the Sacred Table** (Dragon Tree, 110pp booklet, \$9.95) by Chuck Montgomery, et al. In two parts: "The World of Delos" ("Visit the strange island cultures of Delos, learn secrets of Delian cosmology, meet the Sea Sprites of the Inverse Islands and match wits with the Mendacian.") and "Introduction to Live-Action Gaming."

**The Monsterous Civilizations of Delos** (Dragon Tree, 97pp booklet, \$9.95) by Ben & Mary Ezzell. "Visit the Ogre Nations of Delos, travel the Forests of Night to meet the Wampyr and Wool-O-The-Wisp and explore the legendary Broken Lands... you will learn the real perils of succubii, how to get a giant drunk and

(maybe) what has become of the fabled Gnoptic Chalice."

**The Hole Delver's Catalog** (Task Force, 68pp, \$10) edited by Mark O'Green. Humorous catalog of off-beat items for adventurers.

### SOURCEBOOKS

**The Complete Krynn Source Book: Leaves From the Inn of the Last Home** (TSR, 256pp, \$12.95) edited by Margaret Weis and Tracy Hickman. Based on the DragonLance series. "Compiled by Tika and Caramon Majere, Proprietors." Information on the timeline, artifacts, legends, maps, a war journal, numerology, herbalism, runes, songs, music, a cookbook, etc.

### MINIATURES

**Green Dragon** (Games Workshop, boxed, \$12). A *Dungeons & Dragons* miniature. Comes in 4 pieces.

**Regiments of Renown: Bugman's Dwarf Rangers** (Games Workshop, boxed, \$20). Contains Command, Standard Bearer, Musician, and Champion models plus 13 trooper models. Also includes 5 regimental multi-figure slottabases and 2 single-figure slottabases plus 16 plastic shields.

**Romulan Whitewind Cruiser** (FASA, blister pack, \$4.50). 1/3900 scale. For *Star Trek III: Starship Combat Role-Playing Game*. In several pieces including base.

### MAGAZINES

**The Canadian Wargames Journal 3** (Canadian Wargamers Group, 28pp digest, \$1.50) edited by Keith N. Martens. Articles on *A House Divided*, *World In Flames*, *Imperium*, *Supremacy*, *Fortress America*, and a historical look at armored warfare in North Africa '42.

**The Chronicles Of Chaos & Pandemonium 9** (Mike Jarrell, 44pp digest, \$3) edited by Mike Jarrell. Special one-time team-up issue. Articles on vampires, character generation for *Stormbringer*, *RuneQuest*, being a devilish game-master, game reviews, etc.

**Gateways: The Progressive Multi-Media Gaming Aid 3** (Gateways, 52pp, \$1.50) edited by Laura Antoniou. Articles on *Star Trek*, *Battletech*, comic books, dragons, etc.

### PLAY-BY-MAIL

**The Illuminated Handbook: A Practical Guide to World Conquest** (FBI, 32pp, \$7). Rulebook for *Illuminati PBM*, based on the card game by Steve Jackson.

### BOARDGAMES

**The ElfQuest Boardgame** (Mayfair, boxed, \$17) by Marc Acres,

et al. Authorized game based on the comicbook series. Includes rules for introductory (4pp) and basic (8pp) games, a 19"x19" game board surface sheet, 49 tiles, 4 pawns, 2 dice, 5 clue counters, a troll strength chart, 56 cards, 52 elf strength counters, and 12 counters for the troll player. For 2-5 players.

**The Warlock of Firetop Mountain** (Games Workshop, boxed, \$25) by Steve Jackson. "A Fighting Fantasy Boardgame." Components: rules (8pp), a 22"x23" map, 6 plastic playing pieces, 15 key challenge cards, 77 encounter pieces, 6 maze cards, a pad of 50 adventure sheets, a monster reference card, and 2 dice. For 2-6 players. Length: 2 hours.

**Blood Bowl: The Game of Fantasy Football** (Games Workshop, boxed, \$25) by Jervis Johnson. A parody of American football for players. Comes with the Rules (20pp—includes a history of the game), a 16"x32" board, 119 counters, a pad of 50 team roster sheets, 30 stands, and two dice.

**Wiz-War** (Jolly Games, boxed, \$10). Comes with rules, four 5"x5" boards, 120 cards, 34 counters, and an 8-sided die. "Cast spells and nab treasures! You can teleport, read minds, blast fireballs, build waterwalls, create and destroy stone walls, shoot deadly waterbolts, paralyze your opponent with fear,..." For 2-4 players. Length: 1 hour.

**Viceroy's: A Game of Exploration and Empires** (Task Force, boxed, \$35) by Mark G. McLaughlin. For 1-7 players. Comes with a 56pp rulebook, a 27"x20" map, 432 counters, 96 cards, playaids, and two dice. "Explore new lands, loot native empires, plunder treasure fleets, sink pirate ships, build an empire, win fame, fortune and glory." Length: 4+ hours.

**La Bataille d'Espagnol-Talavera** (Clash Of Arms, boxed, \$30) by Monte Mattson, et al. Regimental-level simulation of the culminating battle of Wellesley's 1809 counter-offensive in central Spain. Comes with a 32pp standard rules book, a 24pp special rules book, 720 counters, a 34"x44" map, playaids, and 2 dice. Ideal for solitaire study or team play.

### FOR BATTLETECH

**Gray Death Legion** (FASA, 56pp, \$8) by William H. Keith, Jr. Scenario set describing the major battles fought by the Gray Death Legion, as told in three of the Battletech novels. "You will follow the Legion's rise from a mere three 'Mechs to a full combined arms regiment feared and admired by both enemies and friends." Includes 15 scenarios.

**Mercenary's Handbook** (FASA, 104pp, \$12) by J. Andrew Keith. A "supplement describing the mercenary way of life. It details everything from troop capabilities to a mercenary unit's expenses, and from the ins and outs of contract negotiations to the nature of 31st century warfare."

### FOR ELLERY QUEEN'S MYSTERY MAGAZINE GAME

**From the Casebook of Nick Velvet** (Mayfair, 32pp + playaids, \$7) by Jody Lynn Nye. Four mysteries for 1-6 detectives: "The Theft of the Sugar Packet" (timed), "A Very Exclusive Club," "The Theft of the False Bottom," and "The Theft of the Train Game Rules" (timed).

### FOR FEDERATION AND EMPIRE

**Fleet Pack: More of What You Want to Conquer the Galaxy** (Task Force, folder, \$14.95) by the Amarillo Design Bureau. This pack of playaids includes 432 additional counters, 6 capital assault charts, 2 reduced scale maps, a combat record-keeping chart, a survey ship form, a base control chart, and a planet control chart.

### FOR STAR FLEET BATTLES

**Captain's Log 4** (Task Force, 56pp, \$5.95) by the Amarillo Design Bureau. Features the story "Where Wisdom Fails" and a mini-campaign based on it. Plus tactical suggestions, a consolidated rules addenda, a rules cross-index, 6 scenarios, and SSDs of the Tholian TK-5 Destroyer and the Orion OK-6 Battlecruiser.

**Commander's SSD Book 9** (Task Force, 48pp, \$6) by the Amarillo Design Bureau. Contains 45 Commander's SSD Sheets, covering ships from all of the races in the Star Fleet Universe including many new types.

### OTHER GAMES

**Lazer Tag: The Official Game Handbook** (TSR, 96pp, \$7.95) by James M. Ward. "Games for one player, games for hundreds of players, and games for any number in between, plus fun exercises for sharpening your Lazer Tag skills are all included in this book. . . Also featured is the system to rank Lazer Tag Players and to improve their rank and skills."

### GAMEBOOKS

**Doctor Who and the Vortex Crystal** (FASA, 371pp paperback, \$3.95) by William H. Keith, Jr. You as the Doctor "must . . . discover what power is eroding the barriers between Time and Space. . . As the puzzle comes together, The Doctor learns he still faces the greatest challenge, a confron-

tation with the dark lord of the enigmatic Vortex Crystal!"

**Doctor Who and the Rebel's Gamble** (FASA, 371pp paperback, \$3.95) by William H. Keith, Jr. "The Doctor and his Companions travel back to America at the time of the Civil War. There, they learn that a time-loose rebel soldier has discovered how the war turned out and is hard at work making certain that this time around, the South wins!"

**Endless Quest Book 35: Vision Of Doom** (TSR, 160pp paperback, \$2.25) by Mary Kirchoff. A *Dungeons & Dragons* adventure book. "You are certain that your nightmare vision of doom is a prophecy of the future. And if it is, soon the Vampire King will arise from his sleep of living death to roam the land, wreaking his awful revenge, unless you can somehow stop him. . . ."

**Advanced Dungeons & Dragons Adventure Gamebook 12: Curse of the Werewolf** (TSR, 191pp pocketbook, \$2.95) by Chris Martindale. "You arrive home to discover your land in the clutches of an evil sorcerer. You swear revenge, but first you must escape the terrible curse that threatens to turn you into a werewolf!"

**Car Wars Adventure Gamebook 3: Dueltrack** (TSR, 189pp paper-

back, \$2.95) by Scott Haring. "You're the hometown hero, back to challenge the best at the Atlanta Classic. And your sponsor, Simpson Electronics, has just unveiled the RB-4, a robot mechanic/gunner that promises to revolutionize autoduelling!"

**Time Traveler 2: The Legend Of Hiawatha** (Bantam, 80pp paperback, \$2.50) by Carol Gaskin. "More than four hundred years ago, the five tribes of the Iroquois Indians were at war. Only the great Indian leader Hiawatha was powerful enough to bring the tribes together to sign a peace treaty. . . . Join him and be there at the founding of the Iroquois nation."

**The Forgotten Paths of Dailin** (Dragon Tree, 67pp, \$6.95) by Chuck Montgomery. The book version of a Delian-Quest computer adventure. "Why would anyone want to steal a package of Lotus Petals? Unless he can find out, it's probably back to the farm for young Gavin of Moonlark, lowly Sorcerer's Apprentice . . . but finding out is no easy task. . . ."

### COMPUTER GAMES

**Battle Stations!** (Timeline, boxed, \$?) by M.L. Samford and W.P. Worzel. A computer version of

*Battleship* for the Macintosh. For 1-2 players.

### COMICBOOKS

**SnarfQuest: The Book** (TSR, 142pp, \$9.95) by Elmore. "A comic quest for wealth, power, and all that other good stuff. . . . The complete adventure of 'The Quest for the Crown' from *Dragon* magazine. Includes new full-color, never-before-published story!"

### NOVELS

#### FANTASY

**The Light Fantastic** (Colin Smythe, 218pp hardcover, \$17.95) by Terry Pratchett. Sequel to *The Colour Of Magic* in which the inept and cowardly wizard Rincewind was last seen falling off the edge of Discworld. In this, Discworld is moving towards a collision with a malevolent red star, and it has only one possible saviour: Rincewind.

**The Wizards & the Warriors** (Colin Smythe, 352pp hardcover, \$18.95) by Hugh Cook. First volume in the sword & sorcery series *Chronicles of an Age of Darkness* in which the Confederation of Wizards must join forces with their historical enemy, the inhabitants of Rovac, to turn back two perils: The Swarms, and a power

that turns living things to stone and brings rocks to life.

**Binbos of the Death Sun** (TSR, 219pp, \$2.95) by Sharyn McCrumb. "Even before the unscheduled murder of the world's most detestable cult author, Rubicon was destined to go down in fan history as the most outrageous fantasy convention ever. For one thing, there was that costume contest in which pulchritude beat out creativity. . . ."

**Once Upon a Murder** (TSR, 219pp, \$2.95) by Robert J. Randisi and Kevin D. Randle. "On a gray afternoon in Chicago in 1939, Miles Paladon, private detective, is gunned down in an alley. On a green afternoon, on a blood-strewn battlefield in Palandrum, Prince Paladon wakes up with an arrow in his chest, near-victim in a medieval mystery plot. When the detective wakes up—in Palandrum—he finds an arrow where the bullet should be."

#### SCIENCE FICTION

**Amazing Science Fiction Anthology: The Wonder Years 1926-1935** (TSR, 316pp pocketbook, \$3.95) edited by Martin H. Greenberg. The first ten years of *Amazing Stories*. Thirteen stories by H.P. Lovecraft and others. □

# Sleuth Order Form

Name . . . . .  
 Address . . . . .  
 City, State . . . . . zip  
 Telephone ( ) . . . . .

Send check or money order to:  
**SLEUTH PUBLICATIONS, LTD.**  
 2814-19th Street  
 San Francisco CA 94110

Check or money order payable to Sleuth Publications, Ltd., enclosed in the amount of \$ . . . . .  
 VISA     Master Card  
 Account Number:  
 . . . . .  
 Expiration Date: . . . . .  
 Signature: . . . . .

Item No.	Description	Qty	Price Each	Total Price



For credit card orders call toll free  
 (800) 826-7315  
 From California call (415) 821-2912

PRICES SUBJECT TO CHANGE WITHOUT NOTICE

Postage & Handling: Add \$2.00 for first item and 50 cents for each additional item. Shipments are made via UPS whenever possible. Residents outside U.S. add \$3.00 for first item and 50 cents for each additional item, shipped via surface mail.

Sub-Total	
Calif. residents add 6% or 6½% sales tax	
Postage & Handling	
<b>TOTAL ENCLOSED</b>	

# HERE COMES THE JUDGE!!!

Judges Guild close-outs. Hard to find. Use order form on page 39.  
Limited quantity on some items. Please list alternates.

## UNIVERSAL FANTASY SUPPLEMENTS

JG-0014 Ready Ref Sheets . . . . .	(56pp)	\$ 2.99
JG-0034 Modron . . . . .	(32pp)	\$ 3.50
JG-0037 The First Fantasy Campaign . . . . .	(64pp + 2 maps)	\$ 7.98
JG-0052 The Thieves of Fortress Badabaskor . . . . .	(32pp)	\$ 3.00
JG-0055 Gen Con IX Dungeons . . . . .	(32pp)	\$ 3.50
JG-0063 Citadel Of Fire . . . . .	(32pp)	\$ 3.00
JG-0066 Sea Steeds & Wave Riders . . . . .	(32pp + 2 maps)	\$ 6.50
JG-0068 War Cry . . . . .	(32pp + 2 wall charts)	\$ 4.00
JG-0069 Flotilla One . . . . .	(4 maps)	\$ 5.00
JG-0071 Frontier Forts of Kelnore . . . . .	(32pp)	\$ 3.00
JG-0080 Of Skulls and Scrapfaggot Green . . . . .	(56pp)	\$ 4.50
JG-0087 Character Codex . . . . .	(96pp)	\$ 4.50
JG-0088 Dark Tower . . . . .	(72pp)	\$ 5.50
JG-0093 Under the Storm Giant's Castle . . . . .	(32pp)	\$ 3.00
JG-0096 Treasury of Archaic Names . . . . .	(64pp)	\$ 4.95
JG-0102 The Caverns Of Thracia . . . . .	(80pp)	\$ 6.50
JG-0108 Verbosh . . . . .	(80pp)	\$ 6.50
JG-0109 Operation Ogre . . . . .	(32pp)	\$ 3.25
JG-0113 The Book of Treasure Maps . . . . .	(48pp)	\$ 3.95
JG-0240 The Fantasy Cartographer's Field Book . . . . .	(96pp)	\$ 3.98
JG-0260 Portals Of Torsh . . . . .	(48pp)	\$ 3.98
JG-0420 The Unknown Gods . . . . .	(48pp)	\$ 6.00
JG-0440 Temple Book I . . . . .	(64pp)	\$ 3.00
JG-0460 The Book Of Ruins . . . . .	(32pp)	\$ 4.00
JG-0530 Ravenscrag . . . . .	(64pp + 2 maps)	\$ 10.00
JG-0550 Field Guide to Encounters . . . . .	(112pp + 96pp)	\$ 12.00
JG-0560 Portals Of Irontooth . . . . .	(48pp)	\$ 3.98
JG-0630 Dragon's Hall . . . . .	(32pp)	\$ 3.50
JG-0660 Zienteck . . . . .	(32pp)	\$ 3.50
JG-0680 The Tower of Indomitable Circumstance . . . . .	(32pp)	\$ 4.98
JG-0690 Masters Of Mind . . . . .	(80pp)	\$ 7.98
JG-0700 Restormel . . . . .	(32pp + map)	\$ 5.98
JG-0750 The Illhiedrin Book . . . . .	(32pp)	\$ 3.95
JG-0770 Portals Of Twilight . . . . .	(48pp)	\$ 4.98
JG-0800 Glory Hole Dwarven Mine . . . . .	(48pp)	\$ 3.98
JG-0820 Fantastic Personalities . . . . .	(64pp)	\$ 5.98
JG-0820 Heroic Expeditions . . . . .	(48pp)	\$ 3.98
JG-0840 Prey Of Darkness . . . . .	(48pp)	\$ 6.00
JG-0920 Wondrous Relics . . . . .	(32pp)	\$ 3.98
JG-0990 The Book of Treasure Maps III . . . . .	(80pp)	\$ 6.98
JG-1040 Wondrous Weapons . . . . .	(64pp)	\$ 5.98
JG-1130 Druids Of Doom . . . . .	(48pp)	\$ 4.98
JG-1140 Demons Of Dundurn . . . . .	(48pp + map)	\$ 5.98
JG-1170 In Search of Kelandor's Gold . . . . .	(80pp)	\$ 3.00

## CAMPAIGN HEXAGON SUB-SYSTEM

JG-0059 Village Book I . . . . .	(64pp)	\$ 2.75
JG-0060 Castle Book I . . . . .	(64pp)	\$ 2.75
JG-0061 Island Book I . . . . .	(64pp)	\$ 2.75
JG-0104 Village Book 2 . . . . .	(64pp)	\$ 3.00
JG-0140 Castle Book II . . . . .	(64pp)	\$ 3.00
JG-1100 Caves And Caverns . . . . .	(64pp)	\$ 3.98

## WILDERLANDS CAMPAIGN SERIES

JG-0048 Wilderlands of High Fantasy . . . . .	(32pp + 6 maps)	\$ 8.50
JG-0062 City State of the Invincible Overlord . . . . .	(96pp + 2 maps)	\$ 8.00
JG-0067 Fantastic Wilderlands Beyond . . . . .	(32pp + 4 maps)	\$ 8.00
JG-1200 Tarantis . . . . .	(96pp + 96pp + 3 maps)	\$ 14.98

## WILDERNESS BOOKS

JG-0111 Book One: The Mines Of Custalcon . . . . .	(48pp)	\$ 3.95
JG-0270 Book Two: Spies Of Lightelf . . . . .	(48pp)	\$ 4.95
JG-1010 Book Three: Shield Maidens of Sea Rune . . . . .	(80pp)	\$ 6.98
JG-1030 Book Four: Pirates Of Hagrost . . . . .	(48pp)	\$ 4.98
JG-1090 Book Five: Witches Court Marshes . . . . .	(80pp)	\$ 6.98

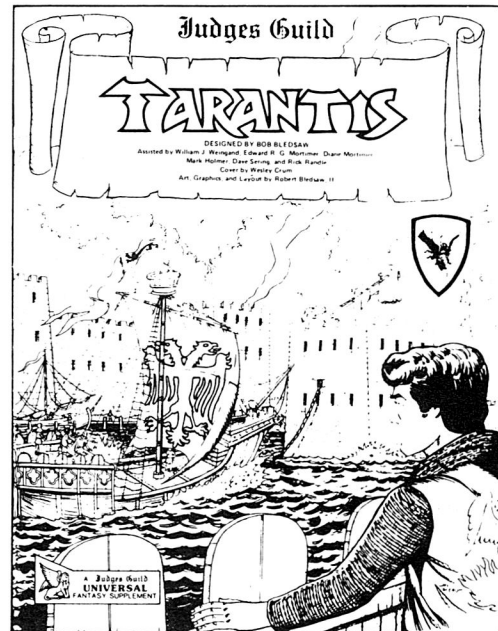

## VALUE PACKS

JG-1021 Fantasy Game Aid Pack . (6 books—\$27.44 value)	\$ 15.00
JG-1022 Fantasy Adventure Pack . (5 books—\$26.90 value)	\$ 15.00
JG-1024 Fantasy Campaign Pack . (5 books—\$26.00 value)	\$ 15.00
JG-1056 The Dungeoneer Value Pack . . . . .	
(13 issues—\$35.05 value)	\$ 15.00
JG-1057 Science Fiction Game Aid Pack . . . . .	
(5 books—\$21.96 value)	\$ 15.00

## MAGAZINES

JG-0073 The Dungeoneer Compendium Issues 1-6 . . . . .	(80pp)	\$ 2.50
JG-0084 The Dungeoneer 10 . . . . .	(64pp)	\$ 1.75
JG-0290 The Dungeoneer 18 . . . . .	(64pp)	\$ 2.80
JG-0160 The Judges Guild Journal 19 . . . . .	(64pp)	\$ 2.80

## FOR RUNEQUEST

JG-0116 Hellpits Of Nightfang . . . . .	(32pp)	\$ 3.00
JG-0170 RuneQuest Judges Shield . . . . .	(4 panels)	\$ 2.50

## FOR SCIENCE-FICTION GAMES

JG-0410 The Astrogators Chartbook . . . . .	(96pp)	\$ 3.98
JG-0740 Port O' Call: Tarlkin's Landing . . . . .	(48pp + map)	\$ 6.98

## FOR TRAVELLER

JG-0078 The Traveller Logbook . . . . .	(64pp)	\$ 3.00
JG-0340 Ley Sector . . . . .	(32pp + map)	\$ 4.98
JG-0350 Darthanon Queen . . . . .	(32pp)	\$ 3.50
JG-0480 Fifty Starbases . . . . .	(96pp)	\$ 5.98
JG-0490 Glimmerdrift Reaches . . . . .	(32pp + map)	\$ 4.98
JG-0500 Doom of the Singing Star . . . . .	(64pp + 2 maps)	\$ 11.98
JG-0590 Crucis Margin . . . . .	(32pp + map)	\$ 5.98
JG-0640 Ghostring . . . . .	(32pp + map)	\$ 5.98
JG-0710 Amycus Probe . . . . .	(32pp)	\$ 5.98
JG-0940 Waspwinter . . . . .	(32pp + map)	\$ 5.98
JG-0960 Darkling Ship . . . . .	(32pp)	\$ 3.98

## FOR TUNNELS & TROLLS

JG-0850 Rat on a Stick . . . . .	(32pp)	\$ 3.98
----------------------------------	--------	---------

## FOR VILLAINS & VIGILANTES

JG-0580 Break In at Three Kilometer Island . . . . .	(16pp)	\$ 3.00
--	--------	---------



# Fireland™

THE FANTASY ROLE PLAYING GAME

K

FOR THE ANYWHEN UNIVERSAL ROLE PLAYING SYSTEM



# New Games In Print

Latest games of interest to adventure gamers. Game publishers are encouraged to send samples of their new releases for announcement in this column.

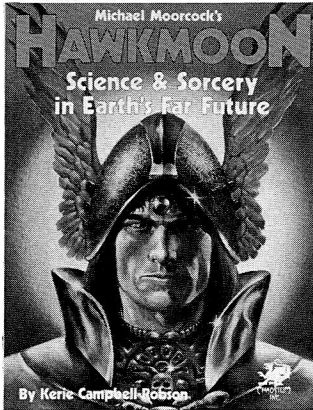

**ROLE-PLAYING GAMES**  
**Hawkmoon: Science & Sorcery in Earth's Far Future** (Chaosium, boxed, \$21.95) by Kerie Campbell-Robson. Based on the novels by Michael Moorcock. Comes with the Players Book (56pp), the Science Book (16pp), the Gamemaster Book (48pp), a reference book (16pp), a 22" x 17" map, a 6-sided die, an 8-sided die, and a 20-sided die.

**Mercenaries, Spies & Private Eyes** (Sleuth, boxed, \$20) by Michael A. Stackpole. "A Contemporary Role-Playing Adventure Game for Solitaire or Group Play." New boxed edition containing a 124pp rulebook, the 32pp solo-scenario *Jade Jaguar*, 10 character sheets, and 3 dice.

**Price Of Freedom: Roleplaying in Occupied America** (West End, boxed, \$19.95) by Greg Costikyan. Includes a 4pp introduction, a 4pp file of pre-generated characters, a 4pp ID papers, a 4pp charts and tables folder, a 32pp Player Book, a 64pp Gamemaster Book, 100 counters, two 11" x 17" maps, a 20-sided die, and a counter tray. For 2-6 players plus gamemaster.

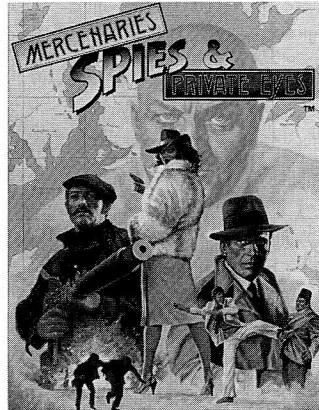
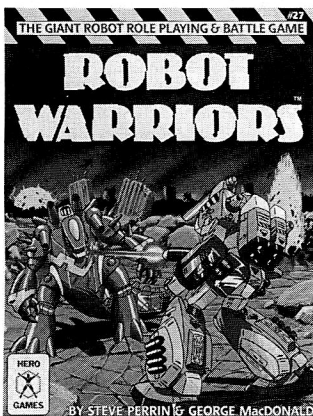

**Robotech Book One: Macross** (Palladium, 110pp, \$9.95) by Kevin Siembieda. Based on the TV series. Information on character creation, insanity, occupational character classes, education and skills, combat, missiles, fighters, the Destroids, the Zentraedi rebels and rogues, background history, scenarios, character stats, and the SDF-1/Super Dimensional Fortress.

**Robot Warriors: The Giant Robot Role Playing & Battle Game** (Hero, 160pp, \$15) by Steve Perrin & George MacDonald. Two games in one: In the Battle Game you'll learn the basics of Robot-to-Robot combat. In the Role Playing Game you create the Robot you want and the Pilot you want to be.

**Traveller: 2300** (GDW, boxed, \$20) by Marc W. Miller, et al. "Mankind Discovers the Stars." Comes with a 48pp Player's Manual, a 48pp Referee's Manual, an 8pp Forms Book, a 22" x 25" Near Star Map, an 8pp Near Star List, an 8pp "The Tricolor's Shadow" adventure, four 6-sided dice, and one 10-sided die.

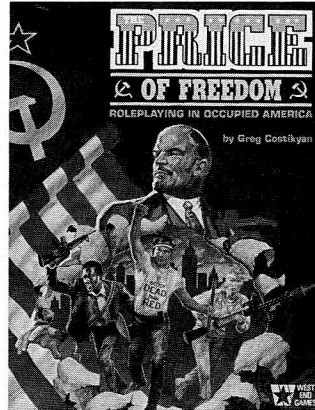
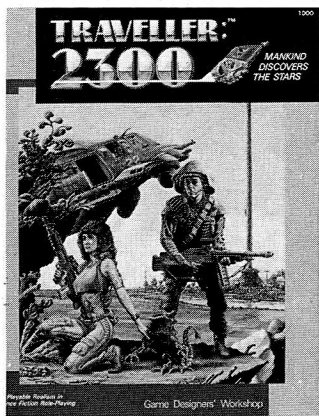

**Warhammer Fantasy Role Play** (Games Workshop, 366pp, \$30) by Richard Halliwell, et al. "A Grim World of Perilous Adventure." Contains players' and gamemaster's chapters, over 100 character careers, over 130 character skills, a combat system, over 150 spells, a guide to the Old World, an introductory scenario, and 8 full-color plates.

## FOR THE ADVANCED DUNGEONS & DRAGONS GAME

**OA3: Ochimo the Spirit Warrior** (TSR, 48pp, \$8) by Jeff Grubb. For character levels 5-7. Uses the *Oriental Adventures* rulebook. Includes descriptions of Akari Island, as well as much information on the lifestyles, attitudes, and history of the most civilized nation in the world: Shou Lung.

**N4: Treasure Hunt** (TSR, 48pp, \$8) by Aaron Allston. For 4-6 characters of levels 0-1. A small band of unwilling adventurers is washed ashore on a small, barren island with rumors of a lost hoard of immense treasures. The player-characters begin the game at 0

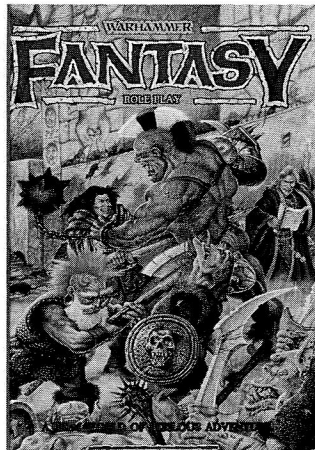

level, without choosing a class, and must work their way up to 1st level.

**H2: The Mines Of Bloodstone** (TSR, 48pp, \$8) by Michael Dobson and Douglas Niles. For character levels 16-18. The second chapter of the Bloodstone Pass saga. "The most deadly dungeon ever designed! High-level characters brave the unexplored corridors of Deepearth to confront perhaps the most feared adversary in the AD&D game."

**I11: Needle** (TSR, 48pp + character cards, \$8) by Frank Mentzer. Adventure for 6-8 characters, levels 8-10. "The king has heard of a great obelisk that towers over a ruined city in a far country. He wants to know more about the obelisk and its strange powers. Your job is to find the obelisk and bring back a report to the king."

## FOR THE ADVANCED DUNGEONS & DRAGONS GAME (Not approved by TSR)

**Beneath Two Suns** (Mayfair, 32pp, \$7) by Troy Denning. For 4-6 characters of skill levels 6-8. Authorized module based on Alan Burt Akers's Dray Prescott novels. "Make your way through dungeons and city byways, defeating city wardens and bizarre monsters."

**Crystal Barrier** (Mayfair, 40pp, \$7) by Cory Glaberson. For 3-5 characters of skill levels 6-8. The adventurers are cast into the Dragonlands where a brutal civil war between the dragons ensues. Cover art by Boris Vallejo.

## FOR ARDUIN GRIMOIRE

**Vol. VI: House of the Rising Sun** (Dragon Tree, 113pp booklet, \$9.95) by David A. Hargrave. New character classes Adventurer

and Beggar; the Street Urchins and Assassins of Arduin (with notes on special weapons and poisons); new monsters and both the natural denizens and special pets of Arduin; new magical spells; alchemy; mystik artifacts; etc.

#### FOR CALL OF CTHULHU

**Terror Australis** (Chaosium, 136pp, \$17.95) by Penelope Love, et al. "Cthulhu Down Under: Australian Background And Adventures." Includes three adventures, as well as extensive information about the Aboriginal inhabitants, their mystical concept of Dreamtime, inhabitants of the Dreamtime, Australian history, transportation in the 1920s, contemporary Australian slang, etc.

#### FOR DC HEROES

**The Joker: Dream Machine** (Mayfair, 32pp, \$7) by Mark Acres. For 6-8 characters of 500-1000 Hero Points. "Deep in Arkham Asylum, a wild-eyed man . . . gibbers and shouts about a mysterious dwarf with the power to make dreams come true. . . No sane person dares to listen. . . But the inmates in Arkham Asylum are not sane. . . The most dangerous of them is The Joker. He believes. . . He plans. . ."

**H.I.V.E.** (Mayfair, 40pp, \$7) by Troy Denning. For 4-6 characters of 500-1000 Hero Points. "Revitalized by the villainous Nightlight, the Hierarchy of International Vengeance and Extermination has created the ultimate terrorist device. . . Can even the New Teen Titans defeat Nightlight's insidious plan for world domination. . .?"

**Night In Gotham** (Mayfair, 40pp, \$7) by Walter Hunt. Includes comprehensive information on Gotham (both its lawful forces and its underworld), new, more detailed maps, and background and stats of its heroes and villains.

#### FOR DELTA FORCE

**Terror At Sea** (Task Force, 48pp, \$7.95) by William H. Keith, Jr. Players must rescue an Italian cruise liner hijacked by terrorists. Includes deck plans, HALO assault rules, descriptions of additional equipment, and more.

#### FOR THE DUNGEONS & DRAGONS GAME

**X12: Skarda's Mirror** (TSR, 48pp, \$8) by Aaron Allston. Expert Game adventure for 4-6 characters of levels 5-8. The adventurers are requested to go inside a mysterious mirror and save the victims who are trapped in it.

**DA2: Temple of the Frog** (TSR, 48pp, \$8) by Dave L. Arneson & David J. Ritchie. A Blackmoor

Expert Game adventure for character levels 10-14. "Deep in the Great Dismal Swamp they must go—far from sunlight and sanity—there to seek and save the captive baroness from the foul Monks of the Swamp."

**IM2: The Wrath Of Olympus** (TSR, 48pp, \$8) by Robert J. Blake. Immortal Game adventure. "The demons of Entropy stand between you and your final goal. Have you the power to rescue the imprisoned Immortals and preserve the Prime Plane?"

#### FOR ELFQUEST

**Elf War: Hubward Adventures on the World of Two Moons** (Chaosium, 40pp, \$5.95) by Elizabeth Cerritelli and Sandy Petersen. A pair of linkable adventures: "Elf War," playable in 1-2 sessions, and the multi-session "Beyond the Frozen Mountains."

#### FOR GURPS

**Battle Maps** (SJG, folder, \$5.95). Three identical 33"x21" one-inch hex maps printed with outdoor terrain on one side and dungeon floor plans on the other. Also includes instructions and cut-out playaids.

**GURPS Fantasy: Magic System and Game World** (SJG, 100pp, \$9.95) by Steve Jackson. Information on magic, over 300 spells, alchemy, the world of Yrth, creatures and characters, and flight.

**GURPS Autoduel: Roleplaying in the World of Car Wars** (SJG, 96pp, \$9.95) by Aaron Allston and Scott Haring. Information on American history since 1990, the autoduelist character, autodueling, and adventures.

#### FOR HARN

**Tharda: Republic Module** (Columbia, 60pp + 22"x17" map, \$14) by Margaret Foy. Information on the Thardic Republic, the mercantile heir to the fallen Corani Empire; Taztos, a legionary fortress in the heart of a hostile wilderness; Telen, the capital of Coranan province; Pamesani Games, the brutal and decadent games held throughout Rethem and the Thardic Republic; and more.

#### FOR MARVEL SUPER HEROES

**MA3: The Ultimate Powers Book** (TSR, 96pp, \$12) by David E. Martin. "Within these covers are nearly 300 powers, gleaned from your favorite comics, science fiction and fantasy novels, and dozens of other sources. All are detailed in *Marvel Super Heroes Advanced Set* terms."

#### FOR MIDDLE-EARTH ROLE PLAYING

**Lords of Middle-Earth** (ICE,

112pp, \$12) by Peter C. Fenlon, et al. Vol. I—The Immortals: Elves, Maiar, and Valar. "This volume describes the first beings to enter Tolkien's world. . . Each race has a general history and a Character Glossary that alphabetically lists the major individuals."

#### FOR PENDRAGON

**The Grey Knight** (Chaosium, 56pp, \$7.95) by Larry DiTillio. The Grey Knight has challenged Arthur's right to rule and accuses him of murdering hundreds of children in northern England. Sir Gawaine, Arthur's best knight and champion, will defend the King's honor in a duel to the death. But Merlin prophecies that Gawaine will die at the hands of the vile Grey Knight. . . .

#### FOR PRICE OF FREEDOM

**Gamemaster Pack** (West End, folder, \$8.95) by Paul Murphy, et al. This 4-panel, 34"x11" screen comes with an 11"x17" map and a 16pp Soviet Generation Book.

**Your Own Private Idaho** (West End, 32pp, \$8.95) by Steve Gilbert. "Three hundred rebels, the grandly named First Idaho Brigade, operate from Idaho's Challis National Forest. Pacific Occupation Front Command has vowed to destroy them—and dispatched an entire motor rifle division to the task. . . ." Includes an 11"x17" map and an 11"x17" folder with playaids.

#### FOR ROLEMASTER

**Rolemaster Companion** (ICE, 93pp, \$12) by R. Mark Colborn. Contains high-level spells, new spell lists, more monsters, more magic items, condensed combat system, new professions, new races, optional system mechanics, etc.

#### FOR STAR TREK

**Trader Captains and Merchant Princes** (FASA, 128pp + 80pp, \$18) by Fantasimulations Associates. ". . . enables players to buy private ships, obtain cargoes, and turn profits no man has turned before. In addition, players and gamemasters will learn the ins and outs of the Federation economy—from pricing goods to trading on the UFP stock exchange, and more."

#### FOR STORMBRINGER OR HAWKMOON

**The Shattered Isle: Rebels Against the Mutant Master** (Chaosium, 64pp, \$6.95) by Kerie Campbell-Robson, et al. In two sections: "Additions" contains new rules, guidelines for vehicular and aerial combat, exotic and powerful weapons, etc. "Scenarios" contains numerous adven-

tures set on Tragic Millennium Earth.

#### FOR TEENAGE MUTANT NINJA TURTLES

**After The Bomb** (Palladium, 48pp, \$6.95) by Erick Wujcik. Information on the Northeastern seaboard of the U.S., character creation, the Empire of Humanity, 6 adventures, and encounter tables.

**Road Hogs** (Palladium, 48pp, \$6.95) by Erick Wujcik. The West Coast of the *After The Bomb* world with 24 new animal descriptions and 9 b&w comicbook pages. Also information on character creation, vehicles, economics, equipment, background world, and a scenario.

#### FOR TRAVELLER: 2300

**Energy Curve: A Marooned Expedition on the Kafer Frontier** (GDW, 48pp, \$8) by Timothy B. Brown. "As the crew of the survey ship *LaFarge*, you live out the thrill of discovering a truly alien world. Survival will be difficult, and will probably depend on the cooperation of a native alien race of beings."

**Kafer Dawn: The Front Line of Mankind's Fight for Survival** (GDW, 48pp, \$8) by William H. Keith, Jr. "From the time the players ground ship on *Aurore* as raw recruits to the time they participate in the final drive against the last major groupings of Kafers in the hotback, they will gradually learn more and more about their violent but complex enemy."

#### FOR TWILIGHT: 2000

**RDF Sourcebook** (GDW, 48pp, \$7) by Frank Frey. Sets the stage for a series of adventure modules. Information on southern Iran, political organizations, military organizations, orders of battle, personalities, character generation, new equipment, etc.

**Armies of the Night** (GDW, 48pp, \$7) by William H. Keith, Jr. Puts the players' group into the middle of New York City two years after the nukes fell, with the mission of restoring it to government control. "There are a few problems, of course . . . such as the fact that the city doesn't want to be controlled . . . and theirs is the ninth group to be given this same mission."

**Gateway to the Spanish Main** (GDW, 48pp, \$7) by Thomas E. Mulkey. Set around a replica of the *USS Constitution* built in 1987. "The players will become crew members aboard the sailing vessel and will eventually be plunged into a plot of treachery, kidnapping, and piracy in the Caribbean Islands. . . ."

Continued on page 38

# Book Reviews



Publications of interest  
to our valiant readers  
of action-adventure books.

## Battletech

### DECISION AT THUNDER RIFT

By William H. Keith, Jr.  
(FASA \$3.95)

Reviewed by W. Peter Miller

*DECISION AT Thunder Rift* is the first in a series of novels set in the Battletech universe. FASA's Battletech "future history" is rich and interesting, yet incomplete and vague in places. This is probably intentional because it is the history of a fallen interstellar government; a huge bureaucracy that has splintered into various empires, commonwealths, and kingdoms. The so-called "Succession Wars" have been raging for hundreds of years. Throughout the years of war, much knowledge about the past has been lost. Starships and other ultra hi-tech items can no longer be easily manufactured.

Somehow the unilateral elimination of atomic weapons has been achieved. Partial beam weapons, lasers, missiles, and conventional firearms are the weapons most commonly used as tools of war. Towering above the various types of hovercraft and tracked vehicles are huge one-man vertical tanks, bi-pedal and humanoid in shape; the rulers of the ground forces. These 60-ton giants are called BattleMechs. Finally, infantry and ground support personnel slug it out in seeming futility at the feet of the 'Mechs. However, a lone soldier with a well-placed shot with the right anti-'Mech weapon can, with a little luck, topple even the toughest of these armored goliaths.

The ability to manufacture 'Mechs has been lost. The 'Mechs that are in use are century-old, battle-scarred machines. 'Mech technicians, called Astechs, are in great demand and are in a constant battle; salvaging and jerry-rigging parts just to keep the huge machines running. Because of their scarcity, captured Astechs are often coerced into joining the enemy side before they are killed. Attrition during the Succession Wars has hurt all sides greatly.

*Decision at Thunder Rift* is the story of Grayson Carlyle, a young trainee in a Lyran Commonwealth 'Mech lance, Carlyle's Commandos. Grayson is the son of Durant Carlyle, head of the Commandos and a respected MechWarrior. The Commandos have been assigned

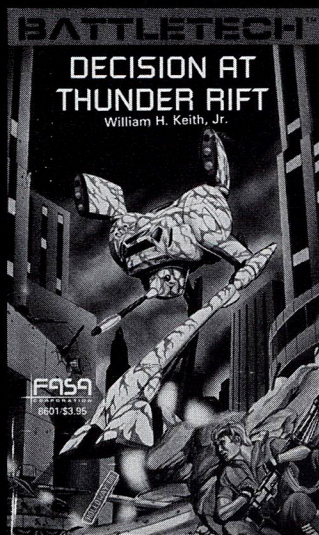

to defend Trellwan, an exotic border world that lies strategically between the Commonwealth and the worlds of the bandit King, Hendrik III. Beyond Hendrik's worlds lie those of the evil Draconic Combine.

To free up forces for other fronts the Commonwealth has reached an agreement with Hendrik. The bandit king has agreed to take on the defense of Trellwan in exchange for trade agreements. As the final treaty ceremonies are drawing to a close all hell breaks loose. There was a spy in the ranks and the 'Mech lance is decimated. The treaty negotiations were just a trap, a set-up for

attack. Grayson's unit frantically retreats off-world and he is left for dead, stranded on a planet overrun with hostile forces.

The only thing that keeps Grayson going is the thought of revenge. To kill the MechWarrior that murdered his father and left the young warrior stranded.

William Keith has done a good job of adapting an adventure game into a decent, involving novel. *Decision at Thunder Rift* doesn't read like the transcription of a Battletech game. It contains the elements missing from a board game that a novel must have to succeed, the reasons for the battles; plot and character.

Keith has a wonderful sense for staging action sequences. While these scenes are occasionally too plotted, too much like "move 3 hexes and fire," it is always clear what is happening with the various factions during the battles. And there are a lot of these.

Between the battles is where court intrigue, conspiracy, and diplomacy comes into play. Grayson must rally the apathetic populace to defeat the invaders. There is also a romantic subplot involving Grayson, a member of the Trell royalty, and a beautiful enemy MechWarrior. While these interludes are brief, they are what keeps the book from merely being descriptions of battles. They are what makes this story interesting.

In adventure novels the reader doesn't usually expect a lot of

character development, and there isn't much here. The dialog is serviceable, though at times awkward. But it gets the job done and tells the story. And Keith has told a story worth reading, both entertaining and insightful to the details of small unit and 'Mech tactics.

The conclusion of the story was very satisfying, especially the resolution of the love triangle. Keith threw in some surprising double-crosses that made what could have been a predictable novel much less so.

On the downside, the violence in this book is too graphic. Keith seems overly interested in describing weapons and their destructiveness to the human body. Granted that this is a story of war, of bitter front-line battles, but in a novel aimed at teenage and young adult readers, the amount of vivid detail isn't necessary. The imagination can fill in details grislier than the finest writer. This book could have used a bit of judicious editing.

The average adventure game fan will find this a fun read. While it is not the finest piece of adventure fiction ever written, it is far from the worst. But if you are a fan of either Battletech or TV series such as *Votoms*, *Mobile Suit Gundam*, or the Americanized *Robotech*, you will enjoy this book a great deal. One hopes Mr. Keith continues to write. I look forward to his next book. □

## Chronicles of the Borderlands BORDERLAND BORDERTOWN

Created by Terri Windling  
and Mark Alan Arnold  
(Signet)

Reviewed by W. Peter Miller

ON THE surface *Borderlands*, and the follow-up book *Bordertown*, seem similar to the anthology series *Thieves' World* in a number of ways. Both are anthologies of short stories with different authors sharing a common setting and group of characters. Both have a gritty urban setting complete with resident cutthroats and brigands. Both would be found in the fantasy section of a bookshop. So, superficially the two series might seem similar. Some might even accuse *Borderlands* of being a rip-off *Thieves' World*.

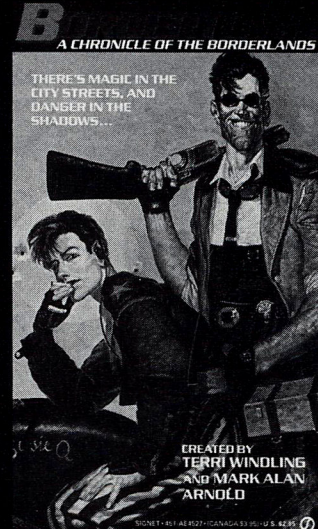
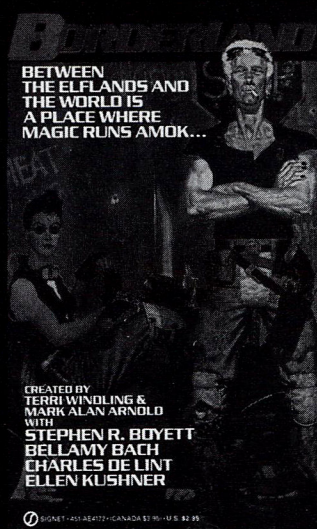

They might . . . until they read the books. It would be difficult indeed to read just one of the two

volumes; they are that engaging. The differences between the *Borderlands* books and just about

anything else out there are enormous. The stories are personal ones, not epic struggles with empires or worlds in the balance. A rock & roll atmosphere permeates all the stories. There is something about a punked-out, mohawked elf in a leather jacket that shatters the Tolkien mold, that allows the characters to be different, to be apart from the previous mythologies.

Once upon a time the world, our world with all its problems

and glories, was going about its normal day-to-day business when all of a sudden, WHAM!, the magical lands of the elves returned. No one on earth knew why they had left thousands of years ago, and no one knew why they were back. And in the Borderlands, the land bordering the world on one side and the Elflands on the other, things were happening. Things were changing. And things, great and horrible creatures, changed by the magic

of the Elflands were wandering.

Bordertown is right at the border. Magic is a powerful force here, technology iffy at best, rock & roll rules the clubs, and gangs rule the streets. The Soho district is neutral territory. Elves and humans mix, though not always peacefully, in the clubs and bars of this slummish district.

Bordertown is a dynamic, changing place. Gangs fight their battles, the politicians struggle with trying to maintain the status

quo. The elves are a constant source of wonder; and frustration in their secrecy about the Elflands. Very little is ever said about the Elflands except that they are very beautiful.

The Chronicles of the Borderlands are heartily recommended to anyone interested in spicing up a fantasy campaign, or those searching for somewhere new, different, and refreshing to set a role-playing campaign. □

## The Darkwar Trilogy

### DOOMSTALKER WARLOCK CEREMONY

By Glen Cook (Questar)

Reviewed by John T. Sapienza, Jr.

WHAT WOULD society be like if witches were real? Could command spirits to carry them through the sky on elaborately carved broomsticks? Could kill with a gesture? That is the theme of the Darkwar Trilogy.

Glen Cook sets his tale in a non-human race on another world than ours, possibly to avoid any prejudices in our society on the subject of what a witch is, but his "meth" are quite human nonetheless. Their world is cooling, and out of the north come attacks of nomads lead by a new leader planning conquest of the south. The primitive village home of the lead character is overrun, and she is saved by the feared witches who dominate the tradertowns to the south. Why are they feared? Because they want it that way. There are actually only a few witches, divided into quarreling communities and factions. They only unite in keeping down the non-talented mass of the population so that they can enjoy their rule.

Cook shows us the witches from within, for the lead character is the most powerful talent in the world, due in part to her upbringing as a huntress in a hostile frontier instead of a softer life in a city. To her, the lack of cooperation and the lack of support for the entire population, characteristic of the primitive tribal society in which she was raised, are a puzzle and a weakness. She comes to understand why witches are hated as well as feared in the course of becoming one herself.

The idea of a minority of the population seizing power to rule because of their mutant powers is a familiar one in fantasy. Katherine Kurtz's popular Deryni series is another example of such a tale told from the point of view of the empowered ones, but there they

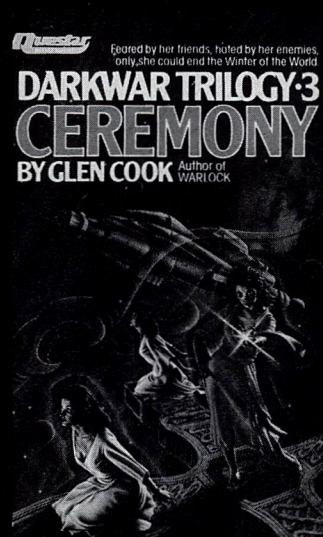
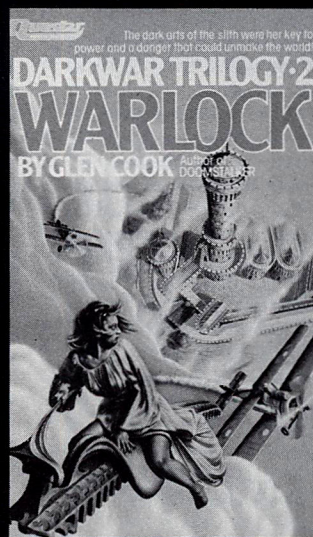
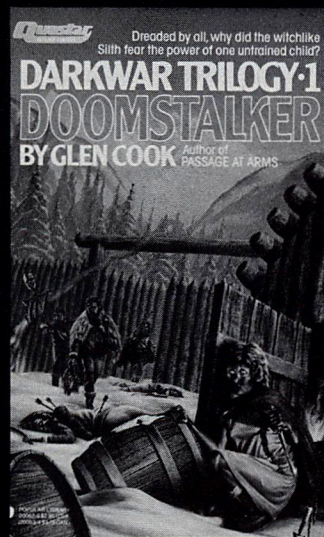

are largely guided by a kinder ethic. Cook's *silth* rule by fear, within their own communities as well as over the planet's population. To Cook, when someone is born with the power to kill, he or she (yes, there are male witches in the books) will usually become arrogant, cruel, and deadly—and suspicious of others of their kind. He suggests that they would be unable to successfully combine to meet even a world disaster.

It's hard to put a label on this story, because Cook combines magic and technology in the same

talent. The witches use energy from another plane by commanding spirits to their work, ghosts that normal folk cannot see. And the witches are inhibited in dealing with spirits in the presence of electronic forces, which gives their enemies a powerful weapon against them. In the middle and last books, witchcraft mixes with space technology in ways that seem to work so long as you are willing to accept the idea of the presence of spirits that can be brought from their plane to ours.

It's a long story, with a lot of

insight into human nature and the way societies work, or fail to work. From a gaming point of view, the interesting part to me was Cook's theory of magic, which he develops in some detail as the story goes along. *RuneQuest* players whose characters use spirit magic may find many good ideas in the trilogy on ways to think of how their characters operate in a world in which spirits exist and can be commanded by shamans. □

## SABAZEL THE WINTER KING

By Lillian Stewart Carl (Ace)

Reviewed by John T. Sapienza, Jr.

DIVINE MAGIC and imperial politics characterize these two related fantasy novels, set in the same world a generation apart. What makes them different from others of their like is the interplay between the empire trying to find peace in the midst of civil war, and the amazon state at its edge trying to maintain its independence. That is a story told at many levels, in the interaction of religions, of kings and queens, and of ordinary soldiers on both sides.

*Sabazel* is the story of the

daughter of a queen who serves her goddess and country in forging an alliance with the son of a king who has his hands full with active rebellion. Worship of the goddess had been suppressed under the rule of the former king. In the course of the novel, the young king learns tolerance of the religion and customs of his neighbors, in part because the alliance is created in the celebration of the rites of the goddess and the conception of a son he will have to fight to get accepted as his heir in the empire.

The amazons, like those of Greek myth, allow no males in their country except at the quarterly religious rites, when men from outside are permitted for

only a short time. Girls born to amazons are raised in Sabazel, while boys are sent over the border to be raised by foster parents. The exclusivity and strangeness of their customs create friction with the neighboring male-dominated kingdoms, to which religious prejudice only adds trouble. To this, the author adds a mix of internal political and religious ambitions, and the result is a lot of thought-provoking conflict.

*The Winter King* is the story of the next generation, the character of the title being the son born to the two lead characters in *Sabazel*. In this novel an empire at peace is invaded by nomads aided by treason, throwing a young prince into exile and once again

Continued on page 34

Approved For Use With

# TRAVELLER<sup>®</sup>

## Undersea

**The Undersea Environment** by J. Andrew Keith. New rule systems simulating the underwater environment: aquatic activities and hazards, the use of underwater gear and equipment, and special events and encounters to help construct underwater encounter tables. (GL-1984 48pp \$5.95)

**The Drenslaar Quest** by William H. Keith, Jr. On the watery world of Yarhfahl, the adventurers join the race to salvage a valuable cargo from the *Drenslaar*, a sunken star freighter. Will they elude detection long enough to complete their task? Makes use of rules and information presented in *The Undersea Environment*. (GL-1985 64pp \$6.95)

## Mountain

**The Mountain Environment** by J. Andrew Keith. Travel and survival in rugged terrain. New rule systems simulate mountaineering and other activities and hazards found on mountainous terrain. Explains the use of mountaineering equipment and includes a guide for the construction of specific mountain situations: special events, encounters, and adventures. (GL-1986 48pp \$5.95)

**Ascent To Anekthor** by J. Andrew Keith. Lady Sandra Lockhart was rich, famous . . . and bored. A thrill-seeker and daredevil, she was always on the lookout for new horizons to conquer. Now she has set her sights on the triple peaks of Anekthor where an old love and an old hatred await Lady Sandra's challenge. Makes use of rules and information presented in *The Mountain Environment*. (GL-1987 56pp \$5.95)

## Desert

**The Desert Environment** by William H. Keith, Jr. Travel and survival in a desert climate. New rule systems simulate all aspects of desert survival, explains the use of desert equipment, and gives guidelines for setting up specific desert situations: special events, encounters, and adventures. (GL-1988 56pp \$6.95)

**Duneraiders** by William H. Keith, Jr. Riches, danger, and mystery lie within the arid wastes of Tash-rakaar, a desert world peopled by the savage and enigmatic Duneraiders. The adventurers soon learn that desert nomads and desert heat aren't the only enemies they face. Makes use of rules and information presented in *The Desert Environment*. (GL-1989 64pp \$6.95)

## Adventure

**A Pilot's Guide to the Drexilthar Subsector** by J. Andrew Keith. From the navigational computer files of the Imperium comes a detailed explanation of a subsector on Reaver's Deep, in the Imperial frontiers. Presents background information on the Deep and on the Drexilthar subsector (setting for the adventures *The Drenslaar Quest* and *Duneraiders*). Each world in the subsector is explored to sufficient depths to be the setting for one or more adventures. (GL-2980 48pp \$5.95)

**Wanted: Adventurers** by John Marshal. From the want ads of a starport news service come 20 short adventure situations. Job opportunities abound for adventurers in this collection of scenarios which can lead a band of characters into anything from a luxury cruise to a mercenary expedition. (GL-1971 48pp \$5.95)

**Startown Liberty** by John Marshal. Startown . . . the rough and tumble district on any world where travellers can find anything from entertainment to the worst sorts of crime and corruption. Condemned by the majority of honest citizens, exploited by the criminal subculture, and visited by starship crews looking for entertainment, information, jobs, and almost everything else, this is "a wretched hive of scum and villainy" . . . this is Startown. (GL-1975 48pp \$5.95)

**Lee's Guide to Interstellar Adventure: Volume 1** by Gregory P. Lee. The journals of the noted galactic wanderer Aramais P. Lee have now been converted into a referee's aid. *Lee's Guide* provides complete planetary specifications and detailed plot outlines for 10 worlds in which the situations taking place on the planet form the basis for a varied range of adventure opportunities, suitable for both small parties and large groups. (GL-1980 48pp \$5.95)

Available thru Sleuth. Use order form on page 39.  
Dealer inquiries welcome.



Dear Tadashi,

THE BIG news this issue is that West End Games has obtained the rights to produce a line of adventure games and accessories based on *Star Wars*, the most successful film series of all time. The first release will be a role-playing game which will be supported by its own line of adventures, supplements, and sourcebooks. Much of the material has been provided by Lucasfilms, about 60%, and the rest will be created by the staff of West End game designers assigned to the project.

The second big news is that TSR has sold *Strategy & Tactics*, their wargaming magazine, to World Wide Wargamers. 3W, the publishers of *The Wargamer* and a line of their own military simulations, will merge their magazine with *S&T*, retaining the *Strategy & Tactics* masthead. The new publication will appear ten times a year with a game in each issue. *The Wargamer* will reappear later this year as a gameless wargame review and analysis magazine.

Additional news in the world of game magazine publishing: DTI is splitting up their *VIP Of Gaming* magazine into two: the wargaming-oriented *Battleplan* and the adventure gaming-oriented *Space Gamer/Fantasy Gamer*. The new editor for the latter will be ANNE JAFFE, formerly of *Game News*.

Flying Buffalo announces that MICHAEL COREY of Berkeley CA is the winner of the 1000th *Battle Plan* play-by-mail game. Only players who have won several previous *Battle Plan* games were allowed in this special game. Designed by RICK LOOMIS, Flying Buffalo has been running this game continuously since 1972.

Steve Jackson Games has picked up the Conan and Horseclans licenses. The Austin TX company will first produce a Conan solo adventure and a worldbook for *GURPS*. The Horseclans worldbook, also for *GURPS*, should appear in late summer. The Horseclans books, written by ROBERT ADAMS, are set in post-holocaust America where savage nomad tribes battle for survival.

The Game Manufacturers Association has voted to sponsor

regional conventions in a manner similar to their sponsorship of the annual ORIGINS convention. This move will allow GAMA to test drive regional conventions before awarding them ORIGINS bids and will allow the regional cons to gain access to useful GAMA connections and promotional support.

Congratulations to TROY CHRISTENSEN who will have his first fantasy role-playing game, *Phantasm Adventure*, published in Japan.

Congrats also to the tenth anniversary of the publication of STEVE JACKSON's *Ogre*, the classic game of human versus a supertank. The game and its supplements have now sold over 100,000 units.

PAUL JAQUAYS has resigned his position with Penguin Products of Connecticut and is now back free-lancing again in Michigan.

There is a new museum in Baltimore: The Armory Museum of Military History contains memorabilia from all of the wars fought by the United States with examples of uniforms, hand weapons, artillery, and artifacts. A highlight of the exhibits is a comprehensive collection of military miniatures ranging from ancient Egyptian thru the Middle Ages and on to modern times as well as fantasy and mythological figures. They also have an extensive display of military simulation games. Located at 4149 Amos Ave, the museum is open from Tuesday thru Saturday, 9 to 5. Admission is free. For more information contact the museum's curator, WILLIAM PRIEST, at (800) 638-3888 or (301) 764-8100.

STUART GORDON, director of *Re-Animator* and *From Beyond*, says: ". . . one of the themes in Lovecraft: Dead people just want to have fun." Also: "Lovecraft's point is, if man knew the truth about life, he'd be driven mad by it."

Love,

Gigi

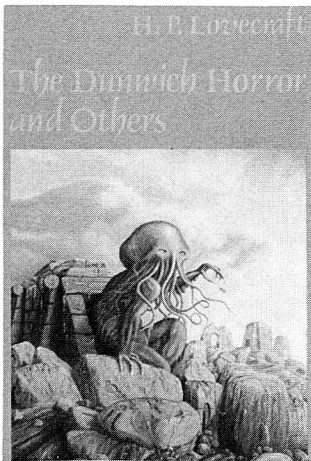

### THE CTHULHU MYTHOS OF H.P. LOVECRAFT

*"Now that time has given us some perspective on his work, I think it is beyond doubt that H.P. Lovecraft has yet to be surpassed as the 20th century's greatest practitioner of the classic horror tale."*

—Stephen King

### The ARKHAM LOVECRAFT

Here at last is the definitive Lovecraft—a three-volume critical edition of the collected macabre fiction that embodies the author's own final thoughts and stylistic preferences. Since Lovecraft's stories initially appeared in the popular magazines of his day and were copyedited in accordance with various prevailing editorial styles, the standard texts are often appallingly corrupt when compared with the original manuscripts and holographs. Over 1500 textual errors occur in the magazine version of "At the Mountains of Madness," while "The Case of Charles Dexter Ward" and "The Dream-Quest of Unknown Kadath" perpetuate "only" 600 and 500 errors respectively!

In preparing an authoritative edition of the Lovecraft fiction Arkham House has consulted the greatest living authority on these texts, Brown University scholar S.T. Joshi, who has devoted over five years to an extensive and painstaking collation of extant manuscript material. The new Arkham Lovecraft is thus the first to be based upon a systematic study of the transmission of the texts and, as such, supersedes all previous editions.

**The Dunwich Horror and Others** (AR-037-8 hardback 433pp \$15.95)

**At the Mountains of Madness and Other Novels** (AR-038-6 hardback 458pp \$16.95)

**Dagon and Other Macabre Tales** (AR-039-4 hardback 448pp \$18.95)

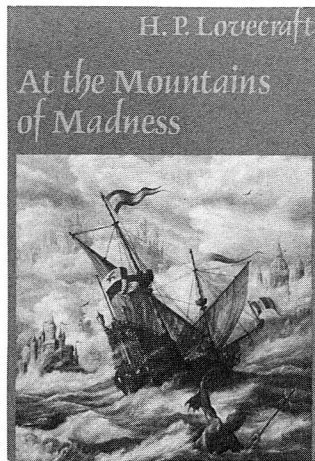

**The Horror in the Museum and Other Revisions** by H.P. Lovecraft. It was not the creative work under his own by-line that was H.P. Lovecraft's major source of income, but the revising of manuscripts submitted by hopeful authors, young and old, that supplied enough income to enable him to eke out a living. Some of these manuscripts were in Lovecraft's own favorite field, that of the macabre, and with these he went to especial pains to produce salable work—even to the extent of completely rewriting many of them, and in the course of so doing, subsuming some of them into the Cthulhu Mythos. This omnibus collection brings together all these "revisions" and in the main belongs solidly in the Lovecraft canon. Jacket by Gahan Wilson. (AR-319 hardback 383pp \$14.95)

**The Watchers Out of Time and Others** by H.P. Lovecraft and August Derleth. At the time of his death in July 1971, August Derleth was writing *The Watchers Out of Time* and had just completed Chapter IV, approximately the halfway point in the novel. After long deliberation, and since this was the final writing of August Derleth, the trustees of Arkham House decided to publish the unfinished novel exactly as Derleth left it, for historical and

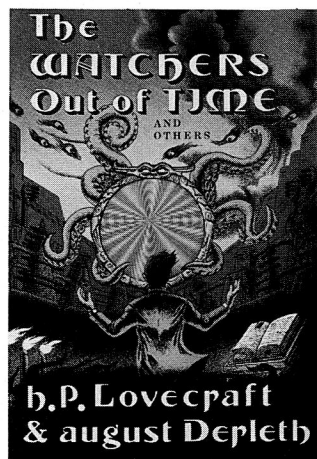

### H. P. Lovecraft Dagon and Other Macabre Tales



literary record, at the end of this omnibus collection of all the posthumous Lovecraft-Derleth collaborations. (AR-033-5 hardback 405pp \$14.95)

**Dwellers In Darkness** by August Derleth. The final collection of fantastic stories and macabre tales by August Derleth affords unerring evidence of this author's mastery in the realm of the uncanny. Whether on a theme of science fiction, a classic ghost story, or a rare contribution to the Cthulhu Mythos, no other writer in recent memory has displayed such complete command over the entire genre of fantasy. (AR-302 hardback \$8.95)

**Lovecraft's Book** by Richard A. Lupoff. In December 1926, the German-American propagandist George Sylvester Viereck sent a letter to Howard Phillips Lovecraft. Viereck's proposal was a simple one: if Lovecraft would write a political tract, a sort of American *Mein Kampf*, Viereck would assure the publication of a volume of Lovecraft's stories as well. Through Viereck's maneuvering, Lovecraft was drawn into a web of intrigue involving Benito Mussolini's overseas agents, the Friends of New Germany, and such nativist radical groups as the Ku Klux Klan and Father Charles

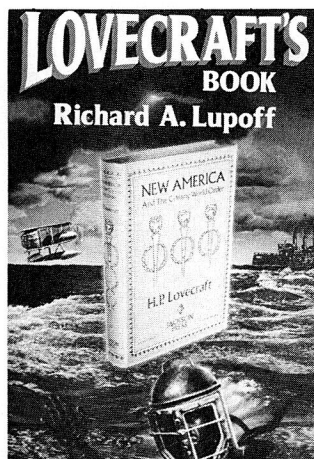

Available thru Sleuth. Use order form on page 39 or send check or money order to Sleuth Publications, Ltd., 2814-19th St., San Francisco CA 94110. Add \$2 postage & handling for first item, 50¢ for each additional item. Foreign orders add an extra \$1. Calif. residents add appropriate 6% or 6½% sales tax.

Coughlin's nascent Social Justice movement. "The finest example of this special genre I've seen yet—a thoroughly delightful and nostalgia-heavy yet by no means altogether unserious romp through the years 1926 and 1927."—Fritz Leiber in *Locus*. (AR-151-X hardback 260pp illustrated \$15.95)

**Howard Phillips Lovecraft: Dreamer on the Nightside** by Frank Belknap Long. The first full-length study of Lovecraft written by one of his oldest and best friends. The author describes his reminiscence as follows: "The Lovecraft book will be an HPL-as-I-remember-him volume and not a biography in the strict sense. It will contain, of course, a chapter or two of straight biographical material and perhaps three chapters of critical appraisal, and a few important quotations from various sources. There also will be some hitherto unpublished material. . . . My primary purpose is to demolish many of the grotesque distortions that have been circulating about Howard and present a portrait of the man that does full justice to his shining gift as both a writer of genius and an extraordinary human being." (AR-068-8 hardback 237pp illustrated \$8.50)

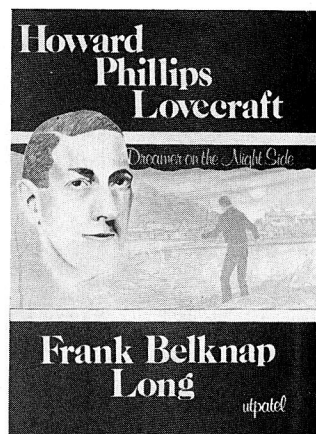

# DON'T LOOK NOW!!

## IT'S **PARANOIA** THE SECOND EDITION

**T**he original PARANOIA is perfect and without flaw in every respect. The Computer says so. The Computer also says the Second Edition is even more perfect! It features: streamlined rules, better organization, improved graphics, and oodles of gamemaster tips. Doubtless, all loyal citizens will want to purchase the Second Edition of PARANOIA. After all, you wouldn't want to disappoint your friend The Computer, would you?

### ■ PARANOIA Book \$11.95

- A new, illustrated 136 page book plus 6 foldouts complete with everything you need: rules & tables, facts & background, innuendoes & outright lies about the people, places, machines, mutations, secret societies, and weapons of PARANOIA.

### ■ PARANOIA Boxed Set \$16.95

- The PARANOIA Book
- The Compleat Troubleshooter, a 16-page booklet describing important Troubleshooter assignments, the Mandatory Bonus Duty Determination Test, and all sorts of nifty equipment (like the Hygiene Officer's skin-core sampler).
- 20-sided Die

Best of all, all existing adventures are compatible with the Second Edition. No fooling.



251 West 30th Street New York, New York 10001

NEW SECOND EDITION  
IN TWO VERSIONS!

A 136 page book and  
the complete boxed set

