

THE SECOND  
**CITADEL  
JOURNAL**

£1.50  
U.S. \$3.00

AUTUMN 85

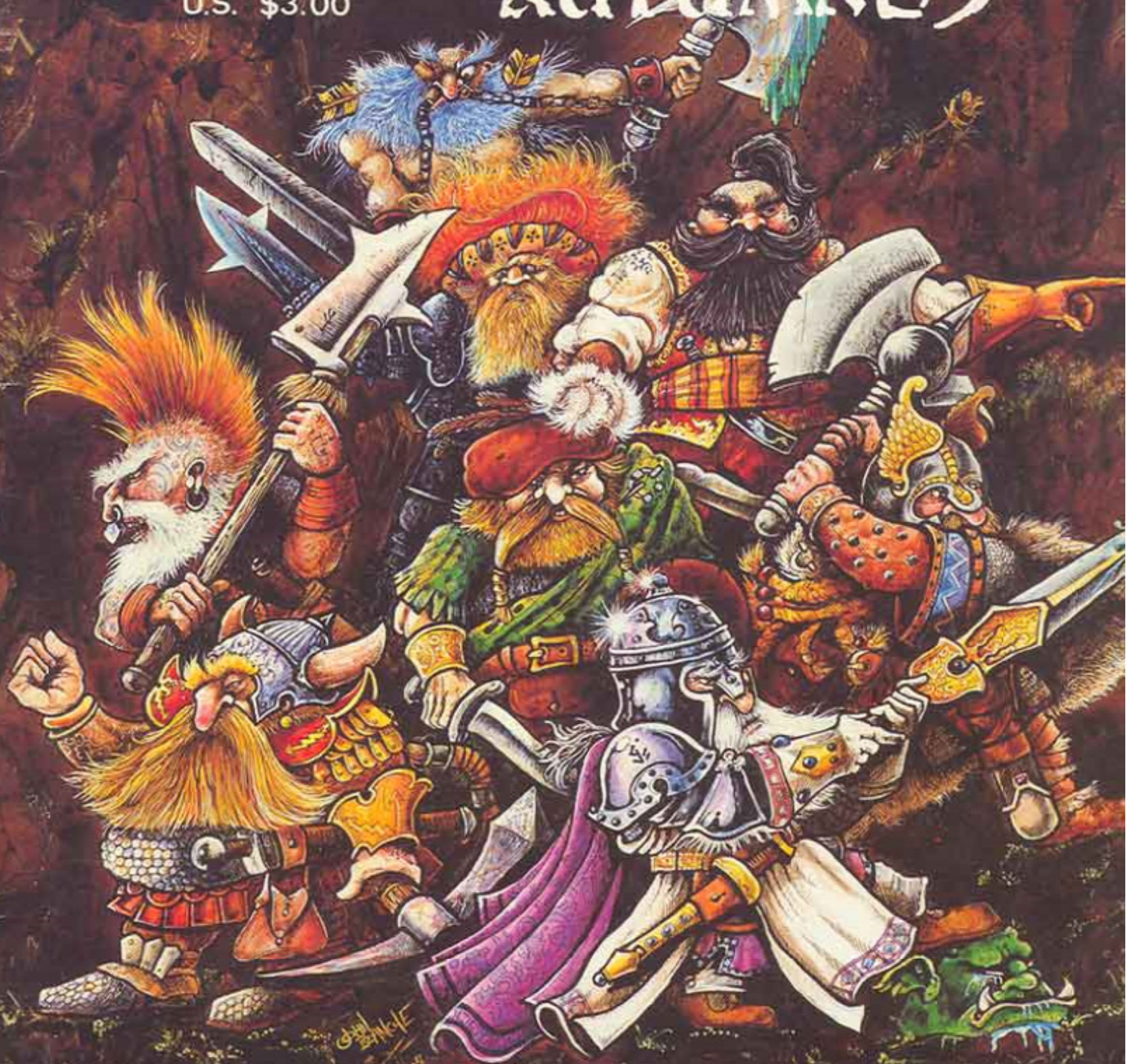

**THE DOLGAN RAIDERS**  
A WARHAMMER SCENARIO  
WITH CARD MODELS  
AND COUNTERS

**PIG PEN MUCKYFOOT'S  
GUIDE TO PAINTING  
FIGURES**  
FIRST PAINT WORK  
IN ACRYLICS

**REGIMENTS OF  
RENOUN**  
MORE UP TO DATE  
DESCRIPTIONS WITH FULL  
WARHAMMER STATS

# YOUR CUT OUT WAGONS & CHARACTERS



Terek



Storyteller

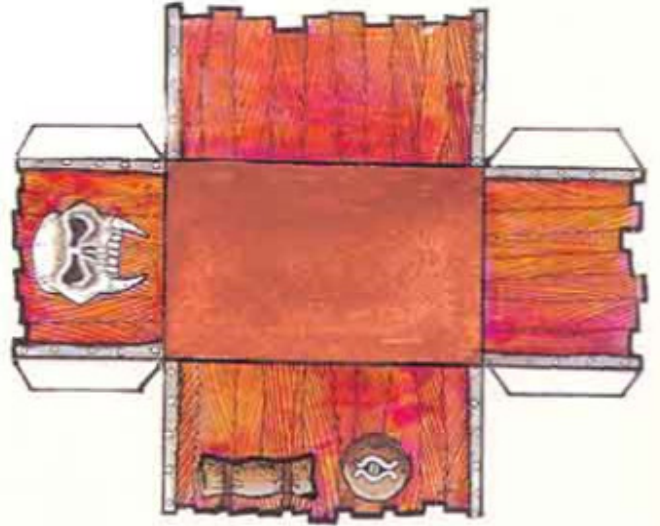

Stephan

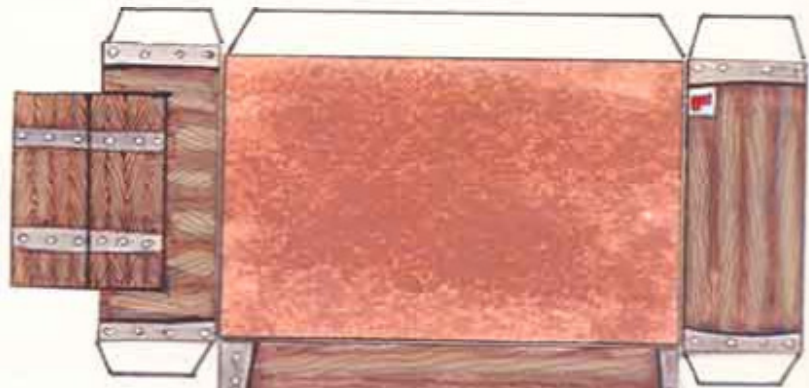
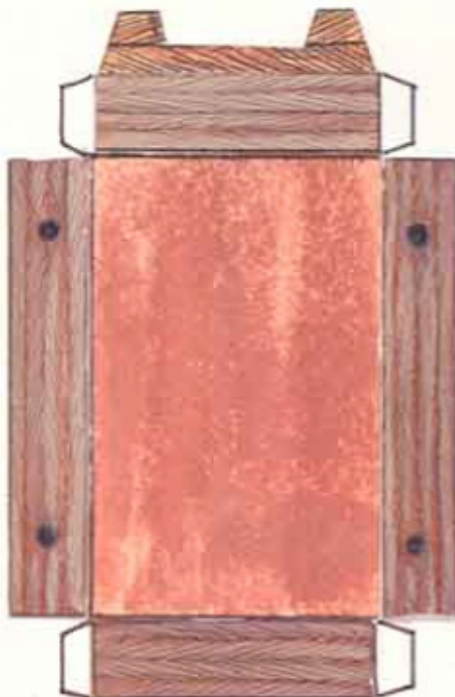

# WELCOME TO THE SECOND CITADEL JOURNAL

Welcome to the second edition of the **Citadel Journal** featuring more articles and features, competitions and information about models, modelling and wargaming within the fantasy genre. Many thanks to all the people who wrote in to say how much they enjoyed the first Journal and to ask when the next one was due out. Well this is it!

The Citadel Journal serves as an update on the current edition of the Citadel Compendium - our fantasy miniatures catalogue. The Compendium is published once a year, and the Journal somewhat irregularly at the moment. We hope to make the Journal a quarterly publication as soon as possible.

The models illustrated in the Compendium and the Journals are only a small sample of our entire ranges. You can find a larger selection in your local hobby shop. Apart from models illustrated, your dealer will be able to supply you with any number of additional models. Remember - Citadel models are changing all the time, bringing you a continuous selection of new adventurers, warriors and monsters. At least six new models are made every single working day!

## CITADEL OPEN DAY

In the past we have always welcomed visitors to our factory, but now that we have moved into new premises at Eastwood we have been obliged to adopt a policy of **NO VISITORS WITHOUT AN APPOINTMENT**. Realising that this would disappoint many people we have decided to institute a series of **CITADEL OPEN DAYS**.

We have had two Open Days so far - in September 84 and March 85. Both proved a great success, with people turning up from all over the country to take part in games, see the special demonstrations or just shop around. Citadel and Games Workshop stands were there, providing customers with an unparalleled selection of models and games. There was plenty to look at too, with Warhammer demonstration games, a chariot race, Warhammer Bring and Battle and real live combat out on the lawn with the Viking Soc!



### THE FIRST CITADEL JOURNAL

It will be available. The previous and thoroughly wonderful first edition of the Citadel magazine contains a selection of new illustrations and many amazingly exciting articles and model-making features. Let us let a few examples just to give you the general drift. *Guise and Gorge* - an in-depth Warhammer article on the Lore Wolf models by Joe Dever and Gary Chalk. *One Step Beyond* - a mysteriously entitled painting article by grand-master, black-belt miniaturist and artist John Blanche. *Remnants of Resonance* - Warhammer Battle Rules stats for all current Regiments of Renown based units. *Arms and Armour* - a reasonably good card house model for you to assemble. In addition, as if this wasn't enough, you'll receive artwork by John Blanche, reader's letters, Wt, Warhammer rules, photos and all the usual features. If the very thought of all this doesn't spur you into purchase of issue 1 just only include that you must be *limited* or something.

Some readers would like to obtain a copy. But, you'll be glad to know that the Journal is available at your Citadel retailer, or direct from us, for only £1.50 post free - an absolute bargain!

Our design staff toiled away, creating new models before the eyes of spectators, whilst John Blanche and Tony Ackland painted and doodled as is their wont. Gary Chalk wore the most outrageously tasteless shirt I've ever seen and Joe Dever took the photos. Many thanks to all -and thanks to everyone who came.

Future Open Days will be announced in White Dwarf magazine.

## HATCHLING PLOTS

Collectors of our miniatures surely cannot help but notice the new licensed ranges designed for Lord of the Rings™ and Dungeons & Dragons®. These are really superb figures; some of the best I've seen from our designers. It was a pleasure to watch them modelling away with such enthusiasm. The head-torturer found there was hardly any need to resort to the usual incentives; hot-coals, branding irons, etc.

At the moment our design staff are busy with a two new boxed sets and a whole series of new licensed ranges. The boxed sets are Dwarf Lords of Legend and Lore, and the Fellowship box for the Lord of the Rings™ range.

In addition forthcoming licensed ranges should include figures for the Judge Dredd role-playing game (to be released by Games Workshop very shortly), Dr Who (to accompany FASA's new RPG), and Elric of Melniboné - based on the fantasy novels of Michael Moorcock and 2000AD models in cooperation with Titan Books.

This year will also see the first Citadel 30mm hard plastic model kits - which will go under the ritzy title of **Psychostyrene!** The first pre-production samples look very good indeed, with bodies, weapons and heads all individually moulded, and a choice of different weapons and heads for each body.

A selection of old ex-Citadel models are also sold by Ral Partha amongst their Partha Imports range. However these models are not from the current up to date, full Citadel range that is available only from Games Workshop U.S.A. Only models from Games Workshop U.S.A are permitted to bear the official Citadel brand of assurance of quality.

UNITED STATES  
**GAME WORKSHOP** LTD  
9119 RED BRANCH ROAD  
COLUMBIA  
MD 21043  
TEL 0101 (301) 946 0242

GERMANY  
FANTASY AND SCIENCE-FICTION (DUK)HANDELUNG  
WANDSBECKER CHAUSSÉE 45  
D-2000 HAMBURG 76  
TEL 010 3990 250 6680

SWEDEN  
TARGET GAMES  
STORGATAN  
S-114 55 STOCKHOLM  
TEL 010 4686 19501

CANADA  
RAPMCO INC  
19 CONCESSION ST  
CAMBRIDGE  
ONTARIO

FRANCE  
AGMAT SARL  
STRATE JEUX  
13 RUE POISSIER DE NAUVAU  
75014 PARIS

EUROCKA  
GALERIE DU QUATELLET  
45000 ORLEANS  
LIBRAIRIE DES TANNIERS  
26 RUE DES TANNIERS  
13100 AIX EN PROVENCE

L'ÉCLAIR CLUBE  
24 RUE LÉNAE  
75005 PARIS

JEUX ACTUELS  
BT 554  
27005 CYREUX

RELIAS BOITFLE JEUX DES ARTES  
16 RUE MAURICE-FONVILLÉ  
11301 POLY-CRISTE

JEUX DES CARTES  
1 RUE DE LA BALNE  
75008 PARIS

JEUX DE GUERRE DIFFUSION  
19 RUE JOUFFROY  
75008 PARIS

## AUSTRALIA

JEKKO GAMES  
134 COCHRANES ROAD  
MOORABBIE  
VICTORIA 3192

VENTURA INTERNATIONAL  
83-87 YORK STREET  
SYDNEY 2000

© 1985 GAMES WORKSHOP LTD. ALL RIGHTS RESERVED. GAMES WORKSHOP LTD. IS A REGISTERED TRADEMARK OF GAMES WORKSHOP LTD. IN THE UNITED STATES OF AMERICA AND IN OTHER COUNTRIES. GAMES WORKSHOP LTD. IS A REGISTERED TRADEMARK OF GAMES WORKSHOP LTD. IN THE UNITED STATES OF AMERICA AND IN OTHER COUNTRIES. GAMES WORKSHOP LTD. IS A REGISTERED TRADEMARK OF GAMES WORKSHOP LTD. IN THE UNITED STATES OF AMERICA AND IN OTHER COUNTRIES.

© 1985 GAMES WORKSHOP LTD. ALL RIGHTS RESERVED. GAMES WORKSHOP LTD. IS A REGISTERED TRADEMARK OF GAMES WORKSHOP LTD. IN THE UNITED STATES OF AMERICA AND IN OTHER COUNTRIES. GAMES WORKSHOP LTD. IS A REGISTERED TRADEMARK OF GAMES WORKSHOP LTD. IN THE UNITED STATES OF AMERICA AND IN OTHER COUNTRIES.

© 1985 GAMES WORKSHOP LTD. ALL RIGHTS RESERVED. GAMES WORKSHOP LTD. IS A REGISTERED TRADEMARK OF GAMES WORKSHOP LTD. IN THE UNITED STATES OF AMERICA AND IN OTHER COUNTRIES. GAMES WORKSHOP LTD. IS A REGISTERED TRADEMARK OF GAMES WORKSHOP LTD. IN THE UNITED STATES OF AMERICA AND IN OTHER COUNTRIES.

© 1985 GAMES WORKSHOP LTD. ALL RIGHTS RESERVED. GAMES WORKSHOP LTD. IS A REGISTERED TRADEMARK OF GAMES WORKSHOP LTD. IN THE UNITED STATES OF AMERICA AND IN OTHER COUNTRIES. GAMES WORKSHOP LTD. IS A REGISTERED TRADEMARK OF GAMES WORKSHOP LTD. IN THE UNITED STATES OF AMERICA AND IN OTHER COUNTRIES.

# CITADEL MINIATURES

CHEWTON ST, EASTWOOD, NOTTINGHAM, UK.

TRADE ENQUIRIES Tel (0773) 769731. MAIL ORDER (0773) 769522

<b>Editor in Chief</b>	Bryan Ansell
<b>Editor</b>	Rick Priestley
<b>Art Editor</b>	John Blanche
<b>Production</b>	Richard Ellard
<b>Production Artists</b>	Charlie Elliott and Joanne Podoski
<b>Illustrations by</b>	David Andrews, John Blanche, Charlie Elliott and Tony Ackland
<b>Card Models by</b>	David Andrews
<b>Cover by</b>	John Blanche

## SUBSCRIBE TO THE CITADEL COMPENDIUM AND JOURNAL!



Here is your chance to ensure that you receive the next four Citadel magazines as soon as they are available! Just send us £6 now, and we'll send you the next four magazines, each worth at least £1.50, as they appear and absolutely post free. The next Compendium is due out sometime around Christmas, and the Journal is published irregularly approximately quarterly. Due to the unbelievably chaotic nature of the Citadel art dept. it is impossible to say for certain exactly when magazines will be published, or indeed whether any given magazine will be a Compendium or Journal! Both the Compendium and the Journal are crammed with illustrations from our extensive ranges of metal miniatures, as well as articles on painting, modelling, Warhammer and numerous special features. Take advantage of this unique offer - subscribe now!

Please send me the next four Citadel magazines as they appear (approx. quarterly).

Name

Address

Cheque/PO. to the value of £6 enclosed. (Please make cheques payable to Games Workshop Ltd).



## CONTENTS

INTRODUCTION	3
Welcome to the Citadel Journal	
CONTENTS	4
ROGUES, RIFF-RAFF AND VAGABONDS	5
Citadel designers exposed	
THE DOLGAN RAIDERS	6
A Warhammer scenario by D. P. O'Connor	
PIGPN MUCKYFOOT'S GUIDE TO PAINTING FIGURES	11
Rapid painting techniques explained by Andy Faulkner	
REGIMENTS OF RENOWN	14
Further stats and descriptions for your Warhammer games	
BANEFUL BANNERS	17
Illustrated flags from John Blanche	
PHOTO-PAGE	19
A full colour spread of Citadel miniatures, painted and photographed by the experts.	
FIGHTING FANTASY	20
The 60mm range and accessories illustrated in full colour	
ADDITIONS TO THE COMPENDIUM SELECTION	23
New models from Citadel	
VESTMENTS OF VILENESS	39
Our new competition	
ARCANE ARMOURIALS	40
The winners of our last competition	
GIANTS, TITANS AND GIANT DEMONS ON A BUDGET	42
A simple project for Warhammer players	
A FISTFUL OF FIGURES	45
Andy Howes of the Player's Guild discusses the art of scenic modelling	
IN PURSUIT	48
Rick Priestley examines the pursuit rule in Warhammer	
THE KNOWN WORLD	50
The Warhammer Known World as drawn by the wayward explorer David Andrews	
READERS ART GALLERY	52
ELDRITCH EPISTLES	54
Readers news, views and criticism	
CITADEL'S SPRING OPEN DAY	56
A selection of photos from the day	
ASSEMBLING YOUR CARD MODEL WAGONS	57
David Andrews explains how you can get the best from his latest card models.	

240 years ago we put down one scottish invasion, but sad to relate they have returned. Bob Naismith (left) Tricia and Aly Morrison (below).



Nick Bibby finishing lunch with his usual dignity and aplomb.



Bryan Ansell

CENSORED



Jez Goodwin says hello to all his fans wherever and whatever they are.



Charlie Elliot aglow with unrestrained enthusiasm over a new project.

# Rogues Riff Raff & Vagabonds

Otherwise Known as THE CITADEL DESIGNERS!



Tom Meier gets the bird.



Kev Adams overwhelmed with joy on becoming part of the Citadel design team.



Nick Lund reminisces on the previous evenings beer and curry.



Tony Ackland quietly contemplates the joys of Priestleycide

The Perry twins Alan and Michael resolving a long standing identity crisis.



John Blanche on the look out for Phil Lewis.



John Stallard congratulating Rick Priestley on his dress sense and good taste (Such nice boys).

# THE DOLGAN RAIDERS



## A **WARHAMMER** Scenario devised by D.P. O'Connor

Between the taiga and the deserts lies that part of the Known World called the Northern Steppes. This is a virtually treeless expanse, distinguished by its rich and fertile black soil, hot and long summers, and sparse rainfall. It is without doubt the richest farmland in the world, but ironically, is rarely used for this purpose, with the result that the whole area is covered in lush grasses and wild crops such as oats, barley and wheat.

The steppes are served by several great rivers, which are broad and long in comparison with the rivers of the Old World. Old World rivers tend to be deep and fast, rather than slow and shallow as in the steppes. The rivers are the only place in which one may find shade on the open steppe, for it is along their banks that cool shade is provided by clumps of birch and, further west, oak.

The natural habitat has led to the development of migratory systems along the steppe. Nomadic herdsmen follow an annual pattern of moving herds of cattle, sable deer, and bison onto the grassland pastures throughout the autumn, winter and spring moving back to the riversides for the summer. Some farmsteads are in evidence along the rivers, but, as the summer tends to be somewhat overcast, crops often fail to reach their full ripeness.

The nomadic herdsmen consist of several different races. Humans are common right across the steppe and into the New World, ranging from the caucasian types in the areas beyond the Mountains of Mourn, to the red-skinned of the New World. Goblinoids are common close to the Mountains of Mourn and on the borders of Cathay. Beastmen are rare upon the steppes, although there is a plethora of chaos creatures who hunt there.

### THE DOLGANS

The Dolgans are a typical nomadic group who inhabit the valley of the river Tym in summer and then migrate as far as the Altai Krai, a round trip of over 5000 miles. To call the Dolgans a tribe or nation would be a misnomer, for, like many other nomadic groups, they have no central authority, law or organs of government. Rather, they are a collection of family groups loosely united by the need to co-operate in keeping the herds together and the need to stave off attacks on their wagons, animals and chosen Summer pasture.

Life on the move has endowed the Dolgans with excellent skills of horsemanship. A man's wealth is measured not in the number of head of cattle he owns (for in a Dolgan group cattle are held in common) but in the quality of his horses. A typical Dolgan might own three horses, a riding horse for travel and herding, a brood mare, and a warhorse used for the annual battles in the river

valleys. He will also have a share in the family wagon which transports bedding, tentage and sundry supplies, including a small mobile forge and medicine cabinet.

The Dolgans live mainly off food provided by the herd, and from the grains and roots that grow wild on the steppe. The herd, which is most likely to be bison among the Dolgans, also provides clothing and the means of exchange needed to purchase the iron ores needed for the production of various tools, horse shoes, lance heads and arrow tips. These supplies may be supplemented by goods stolen in raids upon the various caravans that cross the steppe. These caravans are commonly run by Hobgoblins who take goods from northern Cathay to the Mountains of Mourn, returning with slaves and generally poor quality weapons and armour of Goblin manufacture. These caravans are rarely interfered with by the Dolgans, who have no use for extra mouths on the long migration. The caravans that come from northern Cathay are often pillaged, for they contain fine silks and baubles plundered by the Hobgoblins.

### MILITARY ORGANISATION AND TACTICS

The organisation and tactics of the Dolgans are fairly standard throughout the western part of the steppes. Warfare is limited to small scale raids and skirmishes in which each tribe tries to run off with all or part of another tribes herd, or defends a stretch of pasture. Among the human nomads conflict is relatively bloodless, but goblinoids are treated mercilessly and massacres are not unheard of, if not common.

In readiness for the summer struggle for pasture and water rights, one or more Dolgan groups may pool their resources and elect a war leader who takes command of the war party. These war parties rarely exceed two hundred warriors, because of the ecological constraints of gathering so many herds in one place.

The main Weaponry of the Dolgan is the sword, spear, shield and bow. Hobgoblin armour is occasionally re-forged, but this practise is limited by the widespread belief that the metal is contaminated by these evil creatures. Large hunting dogs are also used in combat. These fierce creatures are herd dogs as well as coursers and watch dogs.

Tactics are geared to be wagon and horse in large battles. the usual ploy is to wear down the enemy with bowmen before delivering an attack with horsemen or warriors, depending on the situation. In defence the Dolgans will adopt one of two main courses. They will either move out to engage their attackers, fighting an extremely fluid battle, or they will laager their wagons and attempt to wear down their enemy with bowfire before sallling out to rout them.

## DAILY LIFE ON THE STEPPE

Life on the steppe is arduous. In winter the mean temperature falls well below zero and fierce winds make the position of the horseman extremely uncomfortable. The daily routine of the nomad is fairly rigid and consists of a pre-dawn breakfast of cheese (made in the riders saddle bags) and bison meat left over from the previous day. The Dolgan will stable his horse and then with his colleagues, begin to round up the herd from its nightly straying. By mid-morning this task will be completed and the herd will begin to move in the desired direction. A noon meal may be eaten in the saddle consisting of unleavened bread and perhaps a few mouthfuls of sugar beet liquor. Water is never drunk in the middle of the day, as the Dolgans believe it leads to unnecessary sweating. When the herd has moved about twenty miles, a halt is called and a beast or two will be taken from the herd and slaughtered. A fire is lit immediately and large chunks of the hump are lightly roasted. This is the most succulent part of the animal and is eaten exclusively by the riders, who regard it as a reward for the days work. The rest of the carcass is then taken to the main camp where it is more fully prepared for the whole group.

The evening meal comprises bison meat, bread made from wild crops collected by the children, root vegetables collected in the same way, and cheese. Water is drunk during this meal, to replace moisture lost during the day, and more beet liquor. At sunset the grazing horses are brought into the laager, stabled and hobbled. They continue to wear their saddle bags throughout the night, as they are filled with milk from the goats which accompany the wagons. A watch is set and then the tribe retires to bed in tents carried in the wagons.

## THE CENTAURS

The Dolgans have had a long and profitable relationship with the Centaurs for generations. This relationship is based on a common love of horses and fact that the peculiar build of the Centaur prohibits them from treating injuries to their own hooves. Dolgan skill in equestrian injuries are therefore traded for Centaurian wisdom. The Centaurs are hired as teachers. This is a very amicable trade, as Centaurs love to teach and converse with humans.



## RELIGION AND MAGIC

The gods of the Dolgans are powerful beyond measure, and it is said that they have the ability to guide the stars themselves. This is not so ridiculous as it may sound, for, on the open steppe, the only means of navigation is by checking the position of the stars. The pole-star therefore assumes a central role in the life of a Dolgan nomad. This is essentially it: there is little actual doctrine and few festivals other than the common celebration of the summer and winter solstice.

Magic is also rare, and there is little exchange of magical theory between the various tribes. Each group possesses a storyteller, who acts as both magician and religious minister. Occasionally, the Centaurs will agree to teach a promising individual some additional magical skills. Elementalism is the commonest form of magic among the Dolgans.

## THE GOBLIN NOMADS

Goblin nomads differ greatly from human types. They are not very successful herders, as most animals are scared away by the very smell of Goblins and their herding wolves. They do, however, manage to retain a few herds of the rather docile Yak. On the whole, the steppe goblinoids prefer to prey on other nomads.

Hobgoblin caravans commonly ply the trade route across the steppe, carrying goods and slaves. Most caravans contain a mixture of goblinoid types, although Hobgoblins predominate.

## At the Dolgan Camp

"See 'em again Ivan?"

"Aye, I saw 'em. Makin' more dust than a bison rolling in a sand pit. As soon a Terek gets here we'll elect a war-leader and go banjo the curs."

"You goin' to stand for leader?"

Ivan took a long draught of Beet Liquor, then spat in the fire. "Know anyone else Stephan?" he growled.

"Who're you going to pick as under-leaders?" asked the third man at the fire.

"If you an' Stephan back me against Terek I'll choose you two" replied Ivan.

"What about the dogs?" Yuri asked.

"Damn dogs are no more use than a blind pony. Terek can have 'em. He's their master after all."

"You think Terek will stand for war leader?" Asked Stephan.

"Pah", spat Ivan, "Have you seen the way he drives a herd? I was with him the year he damn near lost his whole family through going too far north. I tell you, no-one in this herd will follow him and neither will half of his."

At that moment there was the rumble of distant wheels and, in the twilight Ivan picked out a lone wagon moving through the herd. "Terek!", he swore, "Now we'll see who will be warleader."

Shortly after Terek and his companions entered the Laager and had been offered the customary hospitalities the voting began. The eldest man present stood and began to speak.

"Now - we have two fine men who would lead us. Or rather you as I'm not going. They are Terek, from our neighbouring herd, and Ivan, from amongst us. So - let the voting begin."

One by one Terek's companions stepped forward and cast the vote of their families, and then the representatives of Ivan's herd did likewise. The old man took the lots and counted them before announcing, "Then it is settled. Ivan is warleader by eight votes to six."

Terek scowled, and his hand moved to draw his scimitar. For a moment all was perfectly silent, and then the disappointed candidate spat upon the ground, turned his back and strode off back to his wagon. Ivan would be warleader, but he had no friend in the hot-blooded hound master.



## And at a Goblin Camp

"Whadaya mean there's no river?" shouted Bagnol. "Of course there's a river!"

"Well go an look for it cos' I've been out all day with me wolf riders and there's no sign of the thing", replied Gutrot angrily. "Anyhow - I thought you said you'd done this trip before."

"Lis'n you sweaty oik", bawled Bagnol, squaring up and grabbing a passing lesser goblin by the ear, "I've done this more times than you've snorted Yak dung."

"Well whadaya gonna do? We've got two barrels of water left, no Ogre feed and we haven't seen any game in weeks."

"Er - 'scuse me," murmured the little goblin as Bagnol began to swing him by the ear, "Grimwald - he sez he sees this human on a horse this morning an' I thought as maybe somebody should go and fetch him here for supper."

"Whaaat!", cried Gutrot, "we're for it now - them murderin' horse boys'll have us for sure."

"Arr stop your moaning," replied Bagnol, "Ere - Kill this, it'll make you feel better." And so saying Bagnol swung the lesser goblin with a mighty crack onto Gutrot's exposed head.

That night, when the Hobgoblins had laagered their wagons, a meeting was held, similar to the one being held simultaneously in the nomad encampment - but perhaps a little more rowdy.

"I'm boss and I'm still in charge", shouted Bagnol. "I'm the only one who's been this way before".

"And the one that's got us all lost - you useless pile of donkey dung," bellowed Gutrot.

With that the two leaders fell upon each other, kicking, brawling and yelling until an amicable decision was reached. Bagnol, leader of the caravan, and Gutrot, leader of the wolf riders, both agreed to keep out of each others way. Then everyone got drunk, and eventually even the guards collapsed into a stinking pile. And so it was that come the next morning the Hobgoblin wagon laager found itself surrounded on all sides by Dolgans. Drums sounded, trumpets roared and domestic animals brayed pitifully. The lesser goblins quaked and whimpered whilst their larger cousins strapped on iron and took up defensive positions within their small wooden fortress.



## THE DOLGAN WARPARTY

The Dolgan warparty is divided up into two divisions. The first division is composed of archers led by Yuri. The second division is composed of fighters led by Stephan.

### Archers - 20 men

M	WS	BS	S	T	W	I	A	Ld	Int	Cl	WP
4	3	3	3	3	1	3	1	7	7	7	7

Archers are armed with bow and sword. Some carry shields, others have mail shirts - counting as a general saving throw of 6.

Yuri is a human champion and an experienced warrior. Raiding caravans is his favourite pastime. He has been known to chase a rich caravan for weeks before closing in for the kill. He is armed with a sword, and carries a shield and has mail armour - giving him a saving throw of 5 or 6.

M	WS	BS	S	T	W	I	A	Ld	Int	Cl	WP
4	4	4	4	3	1	4	1	7	7	7	7

### Fighters - 20 men

M	WS	BS	S	T	W	I	A	Ld	Int	Cl	WP
4	3	3	3	3	1	3	1	7	7	7	7

Fighters are armed with swords and other hand arms. They wear assorted types of armour, and all carry shields, giving them a general saving throw of 5 or 6.

Stephan is a human champion and is if anything even more experienced than his compatriot Yuri. He is apt to derive his courage from the bottom of the beet-wine barrel. The gunge at the bottom of the barrel is enormously potent, and may even effect physiological as well as psychological changes. At the beginning of a charge roll a D6.

- 1,2 No effect  
3,4 Becomes frenzied  
5,6 Becomes a were-bison (use Centaur profile except BS 0)

M	WS	BS	S	T	W	I	A	Ld	Int	Cl	WP
4	4	4	4	3	1	4	1	7	7	7	7

Stephan is armed with a sword, wears mail armour and carries a shield - giving him a saving throw of 5 or 6.

### Terek and the War-dogs

The war dogs of the Dolgans are large, fierce mastiffs. They are huge beasts with powerful and tenacious jaws. To be savaged by a Dolgan mastiff is an unenviable prospect. There are five dogs in all.

M	WS	BS	S	T	W	I	A	Ld	Int	Cl	WP
6	3	0	3	3	1	3	1	8	4	8	8

Terek is armed with a sword, a bow and wears mail armour - giving him a saving throw of 6. He does not carry a shield, as he needs both hands free to control his dogs. He is a human minor hero.

M	WS	BS	S	T	W	I	A	Ld	Int	Cl	WP
4	5	5	4	5	3	3	2	10	6	10	10

### Maramseth the Centaur

Maramseth is the teacher involved in instructing the Dolgan youth. Being a Centaur he is extremely useful in battle and cannot abide Hobgoblins or their kin.

M	WS	BS	S	T	W	I	A	Ld	Int	Cl	WP
8	3	4	4	3	2	3	2	7	7	7	7

### The Storyteller

The storyteller is so called because the Dolgans believe the telling of stories and magic to be one and part of the same thing. The storyteller is a very learned member of the tribe, and a great friend of the Centaur. He is a second level elemental.



M	WS	BS	S	T	W	I	A	Ld	Int	Cl	WP
4	3	3	4	4	2	5	1	8	8	8	9

The storyteller has the following **Spells**. His magical constitution level is 20.

Cure light injury, hand of fire, assault of stone, lightning bolt, clap of thunder, extinguish fire.

**Ivan**

M	WS	BS	S	T	W	I	A	Ld	Int	Cl	WP
4	6	6	4	4	3	6	3	9	9	9	9

Ivan's Runesword has a Lesser Death Rune on goblinoids, a Rune of Swiftmess and a Protection Rune.

### THE HOBGOBLIN CARAVAN

The Hobgoblin caravan is in dire straits - obviously lost, short on water and with dissension growing daily. Bagnol is struggling to keep the caravan together. Gutrot, leader of the wolf riders, has threatened to desert and has already eaten several of the lesser goblins in a fit of spite. The slave ogres, huge lobotomised beasts used to pull the wagons, are showing signs of discontent at the constant lessening of their rations. Although not intelligent enough to actually mutiny, one has already gone rogue and trampled three small goblins before being recaptured.

The caravan comprises of three wagonseach drawn by two ogres. There are 70 assorted goblinoids. It is led by the Hobgoblin Bagnol - who has made the trip before heading west to east, this time he is trying to retrace his steps. The caravan is carrying a cargo of jewels and gold plundered from the Cathan. The Doigan already know that the caravan is full of something valuable.



### The Wagons

There are three wagons each drawn by two lobotomised slave ogres who are permanently chained into their yokes. They move at a rate of 4" a turn with two ogres pulling, and 1" with a single ogre. They can be moved at up to 3" per turn by a combination of smaller creatures pushing and pulling. Each combined 10 strength points moves the wagon 1" up to the maximum of 3".

The wagons count as wooden barricades. Each wagon can be thought of as a mobile building each of toughness 7 and 3 wounds. The wagons are made from wood, and can be set alight by fire as if they were wooden buildings. See the Fire section of Warhammer Battle Rules Combat volume - p48.

The ogres, having suffered the removal of most of their brains, are subject to stupidity and have profiles as follows:-

M	WS	BS	S	T	W	I	A	Ld	Int	Cl	WP
6	3	2	4	5	3	1	2	5	4	5	7

### Lesser Goblins

Lesser goblins always get a raw deal. Ever since leaving the east they have been treated badly. Several have been eaten or tortured and the remainder have been forced to do the most demeaning jobs, such as bathing the ogres' many running sores. There are 10 of these creatures surviving - armed with short swords, clubs and other hand weapons.

M	WS	BS	S	T	W	I	A	Ld	Int	Cl	WP
4	2	3	2	2	1	4	1	5	5	5	5

### Hobgoblins

The Hobgoblins make up the main fighting strength of the caravan. There are thirty of them, and they are all on the way to settle in the Mountains of Mourn. 20 are armed with assorted swords, axes and maces, and wear chainmail and carry a shield. The remaining 10 have no shields or armour, but carry bows instead.

M	WS	BS	S	T	W	I	A	Ld	Int	Cl	WP
4	3	2	3	4	1	3	1	7	6	6	6

### Goblins

There are also twenty ill-assorted camp followers, females and youngsters. These are of many breeds and half-breeds, but should be treated as ordinary goblins.

M	WS	BS	S	T	W	I	A	Ld	Int	Cl	WP
4	2	3	3	3	1	2	1	5	5	5	5

They are armed with hand weapons of one kind or other and either carry a shield or wear armour giving them a save of 6.

### Wolf Riders

The wolf riders were hired for the purpose of scouting ahead as well as for protection against raiders such as the Doigans. There are nine riders and their leader - Gutrot. They are armed with spears and swords, and all wear chainmail as well as carrying shields - giving a 5 or 6 saving throw.

### Wolves

M	WS	BS	S	T	W	I	A	Ld	Int	Cl	WP
9	4	0	3	3	1	3	1	3	4	4	4

### Riders

M	WS	BS	S	T	W	I	A	Ld	Int	Cl	WP
4	2	3	3	3	1	2	1	5	5	5	5

### Gutrot

M	WS	BS	S	T	W	I	A	Ld	Int	Cl	WP
4	4	4	4	4	2	4	2	6	6	6	6



The caravan is led by Bagnol the Hobgoblin. Bagnol is not exactly popular with the other goblinoids as he has managed to get them lost, and it looks as if he's about to get them killed. However, he is a very good fighter, and should provide the others with a vital source of strength. He wears chainmail and carries a shield as well as his double handed war-mace. He has a saving throw of 5 or 6.

#### Bagnol

M	WS	BS	S	T	W	I	A	Ld	Int	Cl	WP
4	5	5	4	4	3	5	3	7	7	7	7

#### Blackeye

Blackeye is the goblinoids' shaman and, luckily for them, a powerful wizard.

M	WS	BS	S	T	W	I	A	Ld	Int	Cl	WP
4	2	3	4	4	2	4	1	6	6	6	7

Blackeye is a level two wizard with the following spells. He has a magical constitution level of 20.

Aura of resistance, cure light injury, fire ball, hold flight, lightning bolt, smash.

#### FIRE

The Dolgan player may well wish to employ fire arrows or torches. This has both pros and cons, after all, the Dolgans want the cargo intact. The Hobgoblins have only the equivalent of 50 buckets of water with which to fight any fires that break out.

Wolves, dogs, horses and other animals will not approach within four inches of a blazing wagon. Lobotomised ogres are also inclined to dislike fire. If the wagon they are yoked to catches fire, take a test on their Cool (2D6 - must score equal to or lower than Cool for success). Unless successful, the creatures will bolt in a random direction. If only one of a pair of ogres fails the test then the wagon halts whilst they fight to the death.

#### VICTORY POINTS

The Dolgans are interested in two things i.e. destroying the goblinoids and robbing the caravan. They wish to do this with the minimum loss to themselves and to the goods caravan. The Dolgan side can be controlled by either one or two players. In the two player game one player takes control of Terek and the warhounds, whilst the other player, as Ivan, takes the remaining troops.

Each wagon captured intact or with less than 10 fire damage points	50
Each wagon captured intact, suffering 10-19 fire damage points during the game	25
Each goblinoid killed	1
Each Dolgan killed	-5
Maramseth the Centaur killed	-30
Ivan killed if Terek player	50
The Hobgoblins are concerned with survival and nothing more. They can be played by either one or two players. In the two player game one player takes the role of Bagnol and another of Gutrot. Gutrot commands only the wolf riders, and is nominally under the control of Bagnol.	
Each wagon retained with less than 10 fire damage points	50
Each wagon retained with 11-19 fire damage points	25
Each Wagon lost	-50
Each remaining wagon with less than two surviving ogres (each ogre)	-10
Each lesser goblin killed	-1
Each other goblinoid killed	-2
Bagnol killed if Gutrot player	50

#### THE DOLGAN RAIDERS DEAL

DOLGAN RAIDERS		PRICE
DR1	Personalities. Ivan, The Storyteller, Terek & his Wardogs	£ 4.75
DR2	Yuri's Bowmen. Yuri & 20 Archers	£ 11.00
DR3	Stephans Swordsmen. Stephan & 20 Fighters	£ 11.00
DR4	The Complete Dolgan Army. ( 50 Miniatures )	£ 24.00
HOBGOBLIN CARAVAN		
DR5	Bagnol and the Hobgoblins. Bagnol, 20 fighters & 10 Archers	£ 14.50
DR6	Gutrot and the Wolfriders. Gutrot, his Wolf & 9 wolfriders	£ 11.50
DR7	Blackeye & the Slave Ogres. Blackeye & 6 Giant Ogres	£ 12.00
DR8	The Camp Followers. 20 Goblins & 10 Lesser Goblins.	£ 9.50
DR9	The Complete Goblin Caravan. ( 78 Miniatures )	£ 42.00
DR10	Wheels for the Caravans.	£ 0.10p Each

DR11 THE COMPLETE ARMIES TOGETHER FOR £ 60.00

These Deals may be ordered from your friendly neighbourhood retailer, or in case of difficulty, direct from Citadel Miniatures with the addition of 60p towards post & packing for U.K. customers, 30% for overseas.

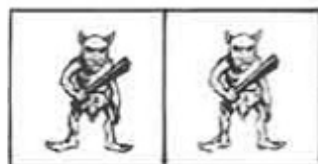
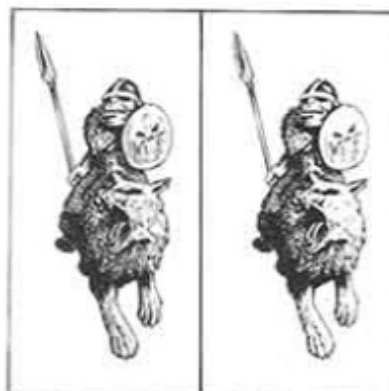

Please feel free to photocopy these counters for your own use only.

# PIGPEN MUCKYFOOT'S GUIDE TO PAINTING FIGURES

Greetings lowly mortals.....

Your quest for knowledge into the workings of the runic brush is at an end. No more will you suffer the stench of turpentine and solid brushes. Never will the paint develop armour in its tin, nor the undercoat be agitated whilst drybrushing. In short, my master, the Graf Faulkner, has deemed to lower himself and divulge the secrets of the fine arts guild. Through my inarticulate words he will pass on the knowledge that makes you a rip-roaring painter! If you are prepared then may your greedy little eyes read on.

If this is the first scroll you have read concerning painting figures then perhaps you should search for the Second Citadel Compendium in the scribe's shop and read the article that appears therein (Sorry the Compendiums have sold out - Ed.) This covers the wide variety of techniques and materials which are available to all budding brush buffs. This will clarify some of the points which all beginners should know about, such as de-flashing, undercoating, basing, varnishing and garnishing. All of these will be mentioned here, but with specific reference to one field only - fast work with acrylics.

My lord, the Jewel of the Heavens, wishes it to be known that he has specialised in this field for several eons, and now finds this particular routine both quick and effective. A high quality finish can be achieved, suitable for friends, clubs, and whoever pushes figures under the castle door. Got your painting cauldron going? Here comes the recipe.

## PREPARATION

- 1 Scalpel or modelling knife (sharp)
- 1 Selection of needle files (optional)
- 1 Razor saw (optional)
- 1 Pin vice with drills (optional)
- 1 Pair pliers (optional)
- 1 Can matt white spray

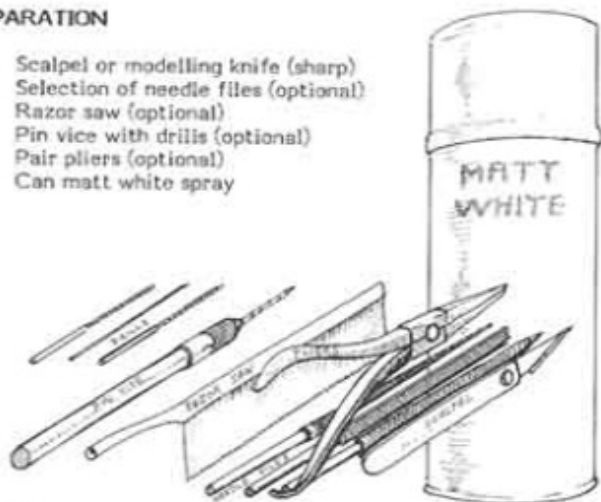

## RECIPE

To prepare raw figures slice or scrape off any unwanted material and leave to stand in a raised area suitable for spraying (upturned yoghurt pots are good!). When you have a reasonable quantity, spray until shiny and wet. Turn gently and spray otherside. Don't forget to spray upwards to hit those areas that normally remain unwashed! Leave to dry for however long it takes (see below). A white undercoat allows the main tone to glow with its true colour.



A good working light is essential. The Graf has ingeniously installed a drying plate above the strong light he uses. Any old lump of sheet aluminium bent at right angles and clamped onto the fitting will do nicely. This means that whilst one figure is drying another can be painted. Neat eh?

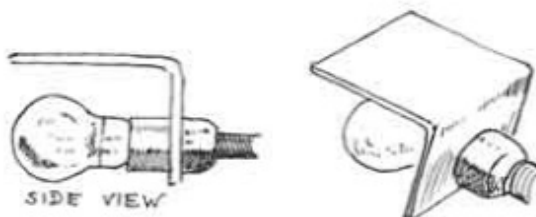

## COOKING UTENSILS

- 1 Selection of brushes
- 1 Selection of Acrylic colours
- 1 Jar of water
- 1 White palette - disposable ones can be made from card covered with clingfilm.
- 1 Steady hand

Brushes, my master always uses the best quality brushes. None of your yetti fur rubbish. They actually work out cheaper in the long run if they are cared for properly, rinsed and not dipped up to the hilt in the paint.

A long bristled size 1 brush (with natural hair not synthetic) has a fine enough point for detailed work and also holds a reasonable amount of paint. Larger brushes are used for larger areas and flattened brushes for drybrushing.

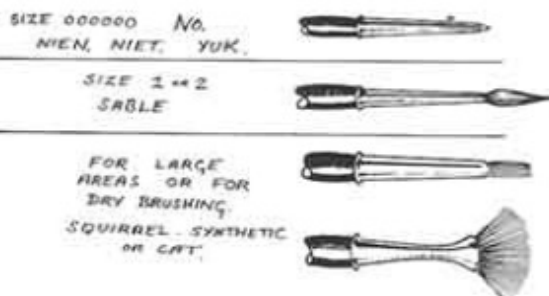

## PAINTS

As I have already stated, the paints we use at the castle are acrylics. They are particularly kind to brushes, which means that they last longer than a cleric at a balrog's tea-party. There are many brands of acrylic paint: Plaka, Rowney, Windsor & Newton, not forgetting Citadel Colour, Armoury, Rose and Tamiya, most of these can be bought in sets or individual pots. Apart from your stock of figures this is likely to be the most pouch-pinching part of your painting career!

There are rules to mixing colours as you are doubtless aware, so choosing the core colours for your paint box is a fairly straight forward affair.

### Core Colours:-

- 1 large tube titanium white
- 1 large tube mars/lamp black
- 1 medium tube cadmium yellow
- 1 medium tube scarlet
- 1 medium tube ultramarine

Cadmium yellow, scarlet and ultramarine are the primary colours. Using the basic principles of primary colours you will be able to mix a variety of tones and alter their shade using white and black to give literally hundreds of different colours (the limit of which is only found through practice).

Obviously you will find other colours which prove invaluable as additional tones for mixing or as useful 'realistic' colours on their own.

These are not essential, but a choice and variety of colour is more fun!

### Useful Colours:-

- Yellow ochre
- Burnt Sienna
- Raw Umber
- Various Greens
- Various Mauves
- Various Blues
- Various Reds
- Various metallics (i.e. copper, silver, gold).

These few extra colours will give you hours of fun just deciding what colour to paint your first monster! With the white undercoat some paints look lovely (even to my gnomish eyes) but some colours need to be slightly brighter than others, such as some oranges and yellows. A few centuries of practice will accustom you to recognising the need to use especially bold colours to enhance the finished effect.

Plaka comes in small glass jars and have a broad selection of bright colours. The paint has an excellent consistency and lasts absolutely yonks!

For metallic colours Armoury and Tamiya paints offer a fairly good range and you can achieve some pretty stunning effects, mixing metallics with other tones. To save you doubloons, I suggest buying one or two new colours at a time and develop your colour mixing skills as you go.

## COLOUR MIXING

Any goblin can mix paint, but to achieve that really subtle texture you have to spend a bit of time working out what you want the finished article to look like.

First of all there are usually three tones to any one section of the figure; the dark tone, the mid-tone and the light-tone. The mid-tone is the actual colour of the garment, such as a crimson cloak. This is painted first and left to dry. The dark-tone goes on next using a technique known as 'washing' - which will be looked at once you mortals have done a bit more reading. 'Drybrushing' needs a bit more practice, but is an excellent method of putting on a light-tone or 'highlighting' the raised surface of a figure.

The techniques are listed below. Using three-shades of colour gives depth and richness beyond compare.

Flesh. It's surprising just how few convincing flesh colours there are on the market stalls these days. Grunt the Pig and I looked for ages and they are all too pale or too pink. So, after consulting a mage we set to work to develop our own. Skin is a pale orange. As a very rough guide mix these quantities and alter accordingly until the paint matches the colour of the skin on the back of your hand.

Take,

- 1 dab of yellow
- 1 dab of red
- 1 dab of yellow ochre

Slowly add white to the mixture until the desired shade is obtained. This takes a while to master (and several washings of the hands) but in the end you'll be able to knock up a convincing skin colour - human skin that is.

## SPECIAL TECHNIQUES

Washing. Not something I know about, personally speaking, but the crux of the matter is consistency of the paint, so the master told me. Washes are applied (usually) on top of the mid-tone coat. The wash should be a dark mix of the mid-tone, but by now you should have guessed that. Mix the paint with water until it is the consistency of milk. Slap it on to the desired surface. Any runs to unwanted areas can be soaked up with the edge of a tissue, or an old sty cleaning rag. The gov'nor has discovered that dark washes, if left to dry over heat, can leave a tide mark - rather like my neck. So half an hour or so at room temperature will allow them to fry ready for.....



Drybrushing. This is simply the technique of reducing the amount of paint on the brush until it is all but dry. The appropriate colour for the highlight should be mixed and most of the paint worked off the brush. When the brush leaves no mark on a clean surface is ready to drybrush. Flick the brush downwards (or in the direction which the light would strike the figure) and the remnants of the paint are picked from the bristles by the raised sections of the figure.



This can also be used to weather, age or grime your figure. If you intend to have special details such as insignia or veins painted on, do this before you drybrush or you will ruin the effect.

Metallics. These paints conform to the rules laid down above although some do not mix as readily as others. Metallics are called for when painting armour. They do not need to be treated differently from other colours, except that you should not try to mix metallics with too much opaque colour as you will quickly lose the gleam of the metal.

Mail armour is painted all silver and washed with black when dry. Once dry you can use the base colour lightened with a touch of white/blue to make it glint like the mithril of old.

Now you have the figure prepared for battle, and mighty seemly does it look! But this image will fade, and many a chip will appear on his shoulder unless he is protected!!!

## VARNISH AND GARNISH

A polyurathane matt varnish gives a natural finish. Use the same technique as you used for undercoating (make sure you use the right can). Allow the figure to dry completely before spraying and preferably make it warm. This is easy if you use a drying plate.

Unless the figure is slottabased it is a good idea to affix your own card base, or use a small coin. Then an all purpose filler, such as tetrion or polyfilla, can be used to texture the base. Spread the filler smoothly into all the crevasses and around the feet. The drying filler can be lifted into peaks or swirled, and once dry it can be washed with raw umber or yellow ochre to create earth or sand effects. Gravel, grit or flock may be embedded or enhance the effect or, as the case may be, a shield or seveded head (snicker, snicker).

Although many odd critters appear as part of fantasy games, it is a good idea to use colours which are as natural as possible. Understandably, not everyone has seen as many ogres as I have, but even red and purple skinned creatures have to look believable. Always plan ahead, particular with acrylics which are permanent. Above all, human, don't be afraid to experiment with colour. Success in brush bashing comes only with experience, and so I will leave you with these wise words, passed on to my master by his martial arts instructor.

When you are young and good at something,  
You are talented.  
When you are old and good at something,  
You are experienced!



If you have followed the procedure correctly, the Demon will now materialize within the pentagram where it will be securely bound.

# WARHAMMER



## FANTASY BATTLE RULES

by Bryan Ansell, Richard Halliwell & Richard Priestley

Within the WARHAMMER Fantasy Battle Rules, you will find all the information needed to enable you to re-create fantastic battles on the tabletop. Players take command of powerful armies, cunning wizards and mighty heroes in a world where magic works and the nightmare creatures of legend are deadly real.

To play WARHAMMER battles, you will need the rulebooks in this set, a selection of models, and dice. This box also contains a small selection of full-colour card models to enable you to fight out the introductory scenario. Dice and three-dimensional models are not included.

### WHAT YOU GET:

- BOOK 1: COMBAT - The complete rules for fighting tabletop fantasy battles with miniature figures
- BOOK 2: BATTLE MAGIC - This details the magic system for introducing magic and wizards into the fray
- BOOK 3: BATTLE BESTIARY - A book of fantastic creatures complete with their battle statistics
- PLAYSHEET - This bears all the combat tables for easy reference in play
- THE MAGNIFICENT SVEN - An introductory scenario
- CARD-CHARACTER SHEET - Cardboard characters for use in The Magnificent Sven

ARTISTS: Box art by John Blanche; book covers and interior art by John Blanche and Tony Ackland.

GAMES DESIGNERS: Bryan Ansell, Richard Halliwell and Richard Priestley



ONLY  
£ 9.95

AVAILABLE NOW FROM ALL GOOD  
GAMES SHOPS

OR DIRECT FROM CITADEL MINIATURES (POST FREE)

# WARHAMMER

## REGIMENTS OF RENOWN



### THE DISCIPLES OF THE RED REDEMPTION



The Red Redemption was born during the bitter religious wars fought between the Men of the West and the swarthy Arabians. Amongst the countless factions of crusading warriors, those known only as the Brotherhood were surely the most feared and the most powerful.

As with all protracted wars, there were long periods of inactivity, whilst supplies were organised, spies sent out or paltry scouting missions undertaken. Such lulls were anathema to the more zealous of the warrior-priests of the Brotherhood. They hated sitting around whilst they knew the Arabians were out there being, well, downright Arabian.

Eroneus Balbadron was one such frustrated fanatic. Eroneus fell into a black mood whenever the fighting got held up. Each stoppage caused his moods to become even blacker; indeed, legend has it that his skin and hair turned completely black during this time. His frustration turned easily to anger, and the anger grew inside him until it was almost a palpable thing. He sought solace in the holy books of the Brotherhood, but to no avail. His anger grew and grew until he became crazed and twisted with it. His hatred of Arabians became a hatred for all.

Presently, a very strange thing happened that was to change the course of Eroneus's life, and the lives of countless others also. It was a dark evening, and the Brotherhood has just captured the ruins of an ancient temple from a group of Arabians. The enemy has hardly put up any resistance, and the fight had been a most disappointing affair. It was as he searched the ruins for any signs of the enemy that Eroneus saw a curious book, its cover barely visible as it lay on the floor. Eroneus compulsively picked it up and sought secrecy in the ruined remains of a sunken room.

Eroneus placed his torch in a bracket by the wall, and feverishly spread the book in front of him. Kneeling before it he began to read. To say that what he read was a bombshell would understate the impact that the volume had on him. In truth his crazed mind could not at first believe that it was possible: this aged book contained ..... the truth. Eroneus was overwhelmed by a feeling of physical, spiritual and mental Redemption. The book was a sacred scripture dedicated to and revering the Chaos God of Khorne. Khorne the black God of Battle, the dark Lord of Slaughter, the thirsting God of Blood!

At once Eroneus felt his links with the Brotherhood, and with humanity, permanently broken. In a fever of ecstasy he pounded his face against the chamber walls until all that remained was...well, little enough remained to betray the fact that he had once been human. Only then did he see the black robes and iron masks that hung upon the chamber walls. The iron mask was unnaturally hot and seared his face as he put it on. The black robes soaked the blood from his armour. Eroneus had become the first and greatest of the redemptionists, the Master of the Redemption, and his cry was, 'Be redeemed through blood, saved through slaughter.'

Quickly slaying his former comrades in a chaotic commando style exercise of carnage, Eroneus fled into the world at large. His objectives were unclear, but he was certain that people of the right persuasion would be sure to welcome enlightenment. He was right.

Only a few years after the incident of the Brother-slaying, the cult of the Red Redemption had become established throughout the Old World. In the secret temples of the cult, initiates were introduced to the vile and bloody ways of the mighty God Khorne. The skin was ritually flayed from the face and torso of each initiate. Glowing hot iron face masks and cuirasses formed a new and tougher skin. At last they were permitted to wear the black robes of Khorne. Of course, this resulted in all of the Disciples of the Red Redemption suffering from total and irrevocable madness, but that really didn't bother them too much. (They were more concerned in shedding the blood of heretics, as members of the countless groups of Disciples then spreading the ways of Khorne in the world).

On such group was Darkkoth's Disciples of the Red Redemption. Darkkoth was said to have been initiated by the Master of the Redemption himself, a great honour indeed. His power was such that he could command a group of up to 49 Disciples. The key to this power was the large black book that he always carried - the Darkkoth. This was a transcript of the original scriptive book discovered by Eroneus. It is a very powerful magic item, although its uses are confined to cult practices. Merely looking at the pages of this book would drive any living being insane. The Disciples are immune to this by dint of them already having achieved this particular state of mind. Darkkoth was able to read passages from this book, and herein lies his power. A passage read from the book gives Darkkoth absolute power over any Disciples that hear him. During the initiation ceremony, Darkkoth would read a special passage from the book which so assaulted the mind of the initiate that his personality would be forever shattered. Darkkoth would assess the suitability of the initiate for cult membership by his reaction. If the initiate reacted with extreme violence this was judged to be good, and he would be prepared for flaying and encasement in glowing iron. If the initiate failed to react with sufficient violence he would be given up as a sacrifice to Khorne.





- EQUIPMENT** Flail, shield and mail armour. Rather than a shield Darkhoth carries an additional hand weapon, allowing him to fight double handed. Mordrid the Champion carries no shield or flail, but has a double-handed flail instead.
- BATTLECRY** Be redeemed through blood
- DEEDS** Spreading the ways of Khorne through the Old World by means of slaughter, destruction, arson, murder and the propagation of insanity.
- POINTS VALUES**  
 Darkhoth - 73½  
 Disciple - 9½  
 Champion - 12  
 Extra for Standard - 45  
 Extra for Musician - 19
- SHIELD** The shield, banners and the robes of the Disciples all carry the symbols of the God Khorne.
- UNIFORMS** The robes of the Disciples are black, edged in red. All equipment tends to be black, or dark colours.

Darkhoth - Warrior-Priest of the Red Redemption

Fighting Characteristics								Personal Characteristics			
M	WS	BS	S	T	W	I	A	Ld	Int	Cl	WP
4	6	5	4	5	2	4	2	10	6	10	10

Disciple of the Red Redemption

Fighting Characteristics								Personal Characteristics			
M	WS	BS	S	T	W	I	A	Ld	Int	Cl	WP
4	4	3	3	4	1	2	1	10	5	10	10

Mordrid the Manic - Champion of the Redemption

Fighting Characteristics								Personal Characteristics			
M	WS	BS	S	T	W	I	A	Ld	Int	Cl	WP
4	3	4	4	4	1	3	1	10	5	10	10

## THE AVENGING KNIGHTS OF THE CLEANSING FLAME



"From the ashes of the old are born the new, and the fire shall have cleansed them, and they shall be free of evil."

Chronus Goodheart at the funeral pyre of the Brotherhood.

Chronus Goodheart was a member of a singular band of crusaders in the holy war against the Arabians. He was one of the Brotherhood. Chronus came from a deeply religious family and firmly believed in the ways of the West. He abhorred the swarthy, outlandish men of Araby and their insidiously evil culture. Now he was confronted by the most hideous scene he could possibly have envisaged.

Before him was a sight that turned his stomach, and a stench that appalled both his nostrils and his soul. It was human carrion, carrion that had once been friend and fellow crusader. Chronus and his three companions were puzzled and horrified at the sickening carnage that had fallen upon their fellows. It was the work of no man, or no sane man at least, they reasoned.

They built a great funeral pyre to consume what remained of the Knights of the Brotherhood. As the flames bellowed and roared one of Chronus's Knights made a strange discovery amongst the ruins where the massacre had taken place. Returning to Chronus he told of his find, and Chronus at once investigated. What the young Knight had chanced upon was an underground sanctuary - originally part of a temple, but now hidden amongst the ruins. Entering inside Chronus saw the blood stained frescoes, frescoes that depicted scenes of horror and perversion of an altogether abhuman nature. Worst of all, upon the floor lay the discarded uniform and equipment of a Knight of The Brotherhood.

"Eroneus", he gasped, as he recognised the clothing of one of the company, Eroneus Balbadron, his own cousin.

Chronus's mind was thrown into chaos. Clearly his cousin had been murdered, and in a manner both foul and inhuman. The whole thing stank of some perverse religious ritual, of a terrible sacrifice to who knows what hellish god.

But it was Garland, the standard bearer who glimpsed the truth, for in his youth he had seen the secret woodland temples of the Gods of Chaos, and had heard rumours of their deeds. He came from the forests of the Empire, lands deep enough, and dark enough to hide the minions of chaos and their victims. In the ruins of the temple he recognised the signs.

Chronus was struck dumb at what Garland told him. To find that his own cousin was the monster that had undoubtedly precipitated, if not actually accomplished, the deaths of so many good Knights, was a considerable blow.

The Knights packed the sanctuary with straw, and around the whole circuit of the hill they spread such flammable materials as lay to hand. Within an hour the whole hilltop was on fire, and what little remained of the Knights of The Brotherhood, and of the strange temple, was utterly destroyed. As the flames burned each Knight swore a great and binding oath.

"This shall be our call to arms and symbol, the flame of our burning brothers. We must keep the flame burning until such time as our oath is fulfilled and the world cleansed of the evil of Chaos. Only then can our souls rest in peace. And the flame we shall bear as our device, and the minions of Chaos will come to fear us, and we shall be known as the Avenging Knights of the Cleansing Flame."

So it was that the four Knights travelled abroad in search of Eroneus. They encountered much evidence of his passing, and many men joined them in their quest, for many were the unspoken acts committed by the defilers of Chaos.



- EQUIPMENT** Dagger, spear, mail armour and shield. The standard bearer carries a sword instead of shield and spear. The musician carries a horn instead of shield and spear. Roland the Champion carries the mighty flame-sword instead of shield or spear. Chronus himself carries a mace rather than a spear.
- BATTLECRY** Cleanse them - and they shall be free of evil!
- DEEDS** The Knights continue in their quest, never ceasing or stopping in one place long enough save to eat or rest.
- POINTS VALUES** Chronus - 43  
Knight - 8½  
Champion - 8 + 75 magic sword  
Extra for Standard - 4½  
Extra for Musician - 17½
- SHIELD** The shield, banners and the robes of the Knights all carry the symbol of the flame.
- UNIFORMS** The shields of the Knights are red with yellow flames. Armour and equipment is black, or a very dark green or blue. Spear-staffs are natural wood. The banner is red with the yellow flame device.
- SPECIAL RULES** Roland's sword has a flame attack (Warhammer Magic volume page 27.) The sacred brazier carried by Garland the standard bearer is a powerful reminder to the knights of their oath, whilst it remains intact the whole unit may add +2 to their Cool.



The knights **Hate** Chaos Worshipers. When confronted by Red Redemptionists they add +2 to their dice when testing.

#### Knight of The Cleansing Flame

Fighting Characteristics								Personal Characteristics			
M	WS	BS	S	T	W	I	A	Ld	Int	Cl	WP
4	4	2	4	3	1	4	1	10	7	5	7

Chronus Goodheart

Fighting Characteristics								Personal Characteristics			
M	WS	BS	S	T	W	I	A	Ld	Int	Cl	WP
4	5	5	4	4	2	5	2	10	8	8	8

Roland - Regimental Champion

Fighting Characteristics								Personal Characteristics			
M	WS	BS	S	T	W	I	A	Ld	Int	Cl	WP
4	4	4	4	3	1	4	1	10	7	5	7

Garland - Bearer of the Standard and Holy Brazier

Fighting Characteristics								Personal Characteristics			
M	WS	BS	S	T	W	I	A	Ld	Int	Cl	WP
4	4	4	4	3	1	4	1	10	7	7	7

## BLACK ORCS

Renowned for their relentless brutality towards any living creature regardless of alignment, the Giant Black Orc must be the most terrible of all the Orc species. Their awesome size is reputed to be the result of age old tribal cannibalism whereby the smallest and weakest Orcs would be eaten - often alive. This violent method of selective breeding (known in Orc terms as 'runt nooshing') has produced a breed of Orc that carries the evil traits of its cousins to the very worst excesses. The only saving grace in this is that their great size has not helped their already low racial intelligence.

Bred solely for destruction, the Black Orc can claim no natural genealogy, their origins undoubtedly being the result of some despotic, chaotic wish to create a master warrior. But their violent, unthinking nature leaves them far short of this design.

### PHYSIQUE

Although not much taller than their Orcish cousins, Black Orcs are by far the largest of the Orc race. Their squat, powerfully muscled bodies range in height from 6' to 9' and can sometimes appear as broad as they are tall.

Long centuries of inbreeding has exaggerated the Black Orc features, and their bulldog faces coupled with huge teeth and jaws has earned them the nickname of 'Dog Heads'.

As their name suggests Black Orcs are predominantly dark skinned - commonly dark brown or grey. Very occasionally albinos are born, regarded as ominous gifts from the gods, these sickly few follow the demanding paths of Wyvern trainers and ultimately shamanhood.

### WORLD DISTRIBUTION

Giant Black Orcs are at their most common in the northern tips of the World's Edge Mountains, all over the Dark Lands, and scattered along the northern parts of the Mountains of Mourn. Anywhere there are evil armies, Black Orcs can be found in numbers ranging from a handful to thousands. They seldom settle long in one place preferring to raid upon their neighbours from shifting nomadic encampments.

### UNIFORM

Usually filthy furs and scavenged bits of armour, any type of mail being the most favoured. Helmets would be worn by the more affluent or flamboyant members of the regiment. The size, shape and colour reflects the prowess and standing of the wearer - the larger the better.

Dress and equipment would be dulled and black, functional and invariably covered in layers of crusted gore and rust. Shields would be painted brilliant red, as would the shafts of spears, clubs and hand weapons.

## EZZA UGEZOD'S MOTHER CRUSHERS

Of all the Orcish raiders to have plundered the Old World from the World's Edge Mountains, none have been so feared, or so hated as the Great Black Orcs of the Mother Crusher tribe. Their Great Raids of Hunger continued almost completely unchecked for nearly forty two years, leaving in their wake a trail of butchery seldom equalled in Orcish history.

Despite many efforts to capture and destroy them, the Mother Crushers always managed to avoid traps set for them. On the few occasions they were brought to battle the outcome invariably favoured the Orcs - using their famous juggernaut columns to push aside any resistance.

Their success was due mainly to the inspired leadership of one Orc. Known throughout the tribes as Eeza Ugezod, Orcish legend abounds with stories of this huge and cunning Orc. One such story, typical of the time, concerns the skirmish on the Great Crossing - a huge, natural span bridging one of the few routes through the mountains to the fertile foothills and valleys of the Old World. It was upon this bridge that a group of Orcs led by Eeza Ugezod were attacked by large numbers of Dwarfs and at least one mountain Giant. An extract from the Orcish 'Volees Adgitz' translates as follows.





"We goes miles this day. Last dark we kills many wittering souls, poking and cutting them - but not having times to make it slow and get them good and acrechy. We gets on the Great Crossing and suddenly all around there's Stunty Long Beards (Dwarfs) - trapping us boys and making pain threats. Then they goes all grinning silent, and crashing through the crowd comes a Great One, all drunk up, with great iron boots sparking as it steps, and long spikes and jags hanging off them, all dressed up for Orc stomping. It comes roaring and swaying towards us, swinging its club and making us boys windy and tearful. And the stunties are laughing, saying at last they'll have our pretty fangs to make their stunty women grin and dance. And us bold boys - we bunch up close, but cannot help a little whimpering. But Eeza Ugezod's got no wimper. He waves his axe and swears he's going to cut Great One's feet off and pop them in its face. With this he goes off fast forward and sharp hacks the Great One. Its knees goes one way, its great screaming whiskers goes another. The stunties has one look and go all quiet and shuffly. Then Guted - our champion - he gives an honest war shout and we goes off at them cutting up their little bodies, this way and that, and we collects much headskin with hair on it and ties it to our belts. We paints their juices all over the Great Crossing and we calls it the Red Span. We push all the stunties off it, but keeping a few for screummings later and food for the march. We leaves not too many boys deadstiff and continues our way to make our dearest war and raidings."

No one is quite sure what happened to Eeza Ugezod - he certainly wasn't amongst the hundreds of Black Orc dead after their supernatural defeat at the hands of the Necromantic Chaos Lord Edis Edis.....

#### BATTLE CRY

The Giant Black Orc battle cry can only be termed as an incomprehensible cacophony of abuse and threat. Each individual does his best to shout his neighbour. However, against Dwarven foes they would chorus over and over again the blood curdling battle cry... "Stomp the stunties - stomp the stunties - stunty stomplings fun!"

#### BATTLE TACTICS

On those rare occasions when tribal animosity does not prevail Black Orc tactics are crudely effective. Always consisting of huge columns (juggernauts) led by the best fighters and flanked by archers and wolf riders. Should there be any of the deadly multi-scythed wolf chariots, or mercenary ogres, these would be placed well to the fore. Although cumbersome and easy prey to artillery and magic, these huge formations were well able to plough through and scatter any but the stoutest enemy formations.

#### SPECIAL RULES

Because Black Orcs naturally victimise smaller Goblins and Orcs (occasionally eating them) they are subject to Animosity at +1 on the dice.

#### BLACK ORC WARRIOR

M	WS	BS	S	T	W	I	A	Ld	Int	Cl	WP
4	3	3	4	4	1	3	1	7	5	7	7

#### EEZA UGEZOD - BLACK ORC MAJOR HERO

M	WS	BS	S	T	W	I	A	Ld	Int	Cl	WP
4	6	6	5	5	3	6	3	9	7	9	9

#### BLACK ORC CHAMPION

M	WS	BS	S	T	W	I	A	Ld	Int	Cl	WP
4	4	4	4	4	1	4	1	7	5	7	7

# BANDFUL BANNERS

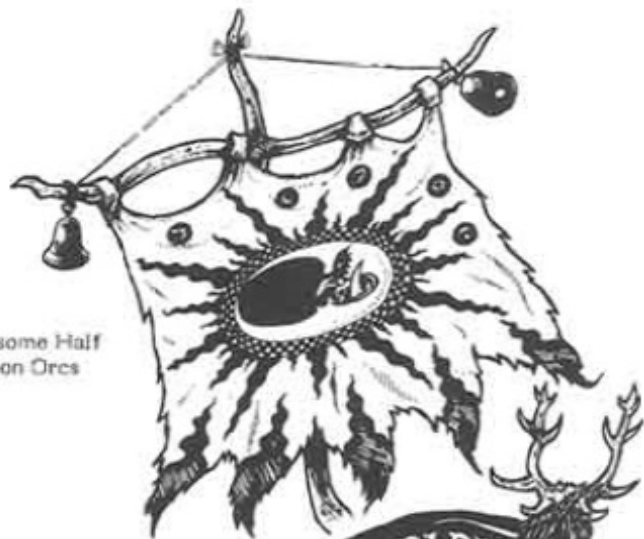

Fearsome Half Moon Orcs



Lords of the Broken Skull



The Undead Legion of Dis



Elves of the Griffon Gate

Look out for the full colour cut out banners in the third Citadel compendium out later this year.



# GOT BLOOD IF YOU WANT IT!

ONLY  
£5.95



## BLOOD BATH AT ORC'S DRIFT

THE SPECTACULAR  
NEW SCENARIO FOR

**WARHAMMER**

AVAILABLE NOW FROM ALL GOOD  
GAME SHOPS OR DIRECT FROM

**CITADEL  
MINIATURES**

CITADEL MINIATURES MAIL ORDER, CHEWTON ST., HILLTOP, EASTWOOD, NOTTS.



A



B



C



D

## PHOTO'S PAGE



E



F



G



I



H

A) D&D Orc painted by John Blanche, photograph by Richard Harcourt.

B) Orc painted by John Blanche & photographed by Charles Elliott.

C) Ghoul painted by Dave Andrews & photographed by Charles Elliott.

D) D&D Fighter painted by Dave Andrews, photograph by Richard Harcourt.

E) Undead Chariot painted & converted by John Blanche, photograph by Richard Harcourt.

F) AD&D Bugbear & Cleric painted & photographed by Phil Lewis.

G) Wizards painted & photographed by Phil Lewis.

H) AD&D Lich painted & photographed by Phil Lewis.

I) Cleric of Melniboné painted & photographed by Charles Elliott.

Dungeons & Dragons, Advanced Dungeons & Dragons are trademarks owned by and used under license from TSR, Inc.

1985 TSR, Inc. All rights reserved.

# FIGHTING FANTASY



THEY'RE HERE - Cutting their way out from Steve Jackson's and Ian Livingstone's best selling games book; the FIGHTING FANTASY models from CITADEL MINIATURES. Mighty thewed barbarians and awesome wizards battle in mortal struggle against the evil denizens of darkness and the black legions of chaos. Each finely detailed figure is moulded in grey plastic and stands approximately 60mm tall (Ogres 80mm) and comes supplied with an assortment of weapons and equipment, including one of a selection of different interchangeable heads or helmets.

Collect them all, and muster your own armies of goodly heroes or foul hordes of bestial monsters.

## HEROES



## WIZARDS



## BARBARIANS



## HEROIC KNIGHTS



## WARRIORS OF CHAOS



## DWARFS



## MONSTERS



### SKELETONS



### GOBLINS



### ORCS



### OGRES

ALL FIGURES 65p EXCEPT OGRES £1.25

# NEW Boxed Sets

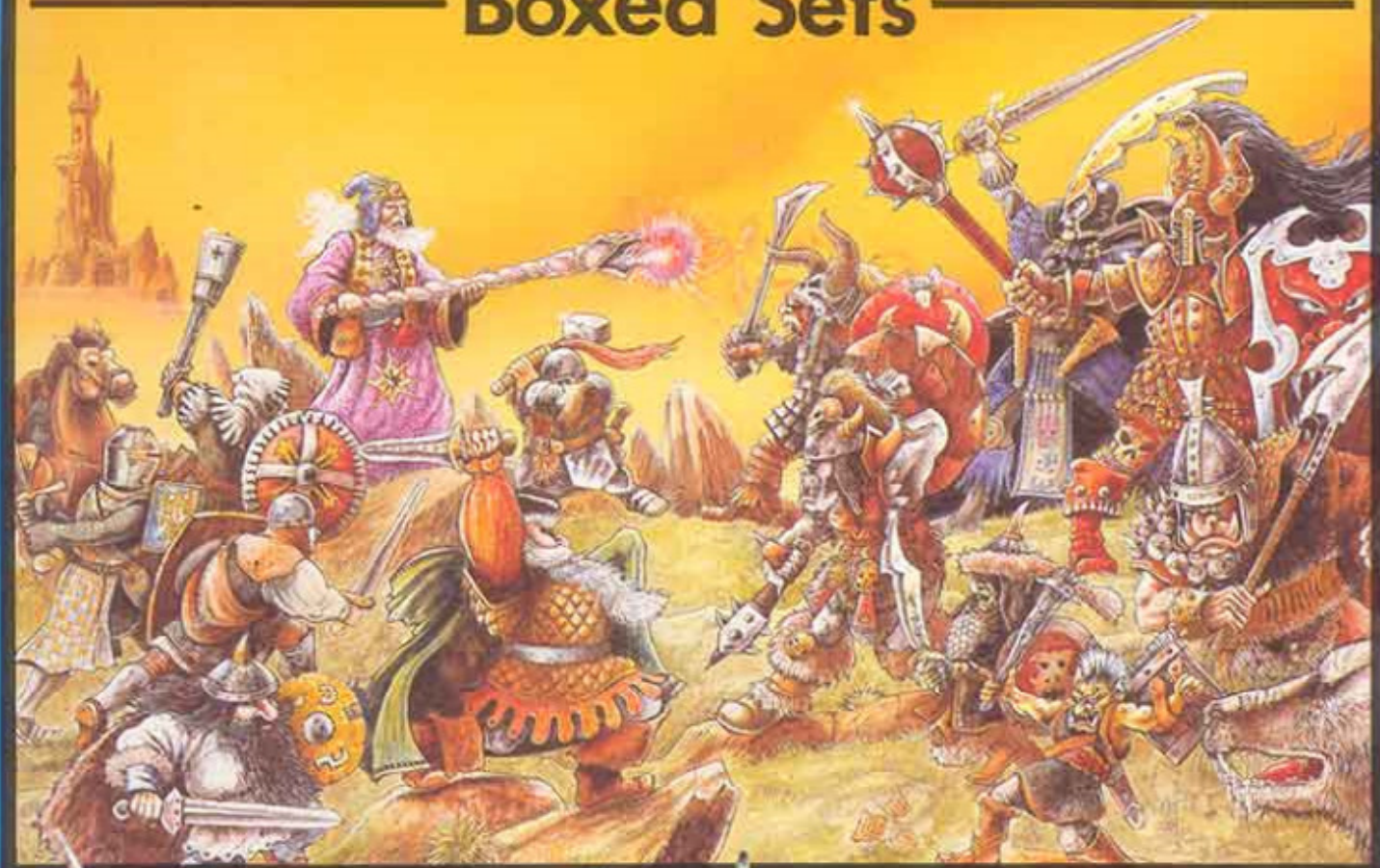

**BC1**  
Adventurers Starter Set

**BC2**  
Monsters Starter Set

# CITADEL MINIATURES

**NOTE.** These new selections of Citadel models are additional to those presented in the *Second Citadel Compendium* and *spring 85 Journal* - they do not represent Citadel's entire range by any means!

**WARNING** - Please remember Citadel miniatures are intended for serious and responsible collectors and gamers - they are not toys. Models contain lead which may be harmful if chewed or swallowed. Citadel miniatures are not recommended for children under 12 years of age.

Most Citadel models now come with a separate styrene Slotta base for gaming and display. Each base has either a pre-cut groove to take the model, or a series of weakened grooves underneath. Use a screwdriver to push out weakened grooves where required (do not use the model tab itself or it will break). Apply glue to the tab on your model and fix to the slotta-base as shown. Slotta-bases provide a stable base for your models and are ideal for displaying your models at their best. Each model comes with an appropriately sized and shaped base, additional slotta-bases can be purchased separately should you wish, for a mere 2p for hexagonal, 20mm & 25mm bases, 3p for horse/monster oblong bases and 6p for 40mm bases, and 5p for flying bases..

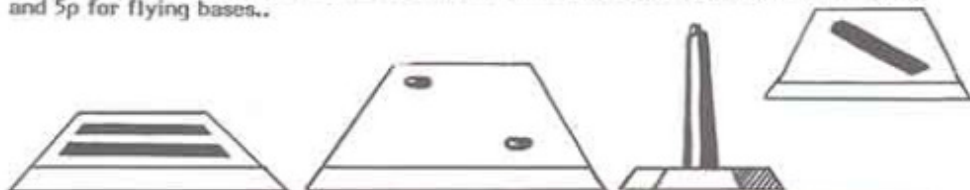

Models indicated come complete with a separate, moulded, hard styrene shield; allowing, for the first time ever, realistic shield thicknesses and enhanced three-dimensional effect. Each metal model is cast with a special shield stud. Attach the shield to the stud using super-glue or similar adhesive. The studs are cunningly moulded so that they can be painted to represent a metal shield boss. By 1986 we will be making special shield design transfers available to fit these clever little devils. You can purchase extra shields for 1p each.



**Requires Assembly** - this symbol indicates that the model or models are cast in two or more parts. Such models will need to be assembled by you. A degree of modelling competence is necessary to construct any multi-part kit, and we do not recommend them for inexperienced or very young modellers.

## DWARVES ·CO6·

Designed by Alan & Michael Perry



Veteran



Sureshot



Very upset Berserker



Noble Warrior



Hero



Retainer



Clan Chief



Axe Dwarf



Bandit



Lord

# CITADEL MINIATURES

## ELVES

C08

Designed by Alj Morrison



Guard



Goblincleaver



Female  
Champion



Clear eye



Swiftfoot



Manfriend



Hero



Bowman



Orc Slayer



Guard



Casualty!

## GOBLINS

C12

Designed by Alan & Michael Perry & Kev Adams



Knee Spiker



Archer



Clubber



Bowman



Leg Biter



Slug Slinger



Bag Blower



Neck Cracker



Sniper



Eye Gouger



Standard Bearer



Head Taker



Mace Wielder



Sharp Blade



Spear Thruster





# CITADEL MINIATURES

## ORCS C15

Designed by Alan & Michael Perry



Shield Bearer

Bladebane

Cyclops

Warlord

Guardsman



Officer



Maulman



Dwarfsmiter



Axe Killer



Maniac



## UNDEAD SAMURAI

### C18

Designed by Aly Morrison



Abo



Mi



Yun



Jin



Li-che



Ep



Zali



Anko



Bek



Yo

# CITADEL MINIATURES

## GIANT OGRES

C23

Designed by Jes Goodwin



Marauder



Oriental Ogre



Warrior Priest



Chaos Ogre



Warlord



Gladiator



Bounty Hunter



Mercenary



## TROGLODYTES

C24

Designed by Trish Morrison



Club Warrior



Noble



High Lord



Club Warrior



Maul



Drummer

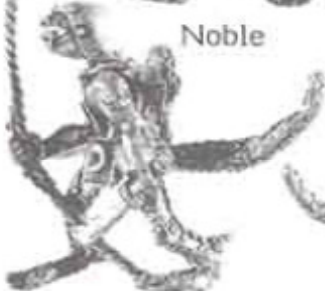

Archer



Spearman



Warlord

# CITADEL MINIATURES

## CHAOS BEASTMEN

C27

Designed by Trish Morrison



Two Head



Turtle Man



Tiger Man



Camel Man



Half Man



Hog Man



Slime Arm



Carrion Man



Cloven Hoof



Kiss of Death

## MONSTERS

C29

Designed by Nick Bibby



Giant Carnivorous Bird



Giant Owl



Turtle Dragon



Plague Elemental



Coatl



Winged Fire Demon

# CITADEL MINIATURES

## GIANT MONSTERS

Designed by Kev Adams

C31



Giant Hill Troll

## ADVENTURE PACKS

Designed by Alan & Michael Perry, Aly Morrison

C33

Supplied with a clear plastic stand



Wizard on Flying Carpet



Chaos Knight



## MONSTERS

C34

Designed by Alan & Michael Perry & Nick Bibby

Supplied with clear plastic stands



Demons of Law



Death Elemental Life Elemental

# CITADEL MINIATURES

## HOBGOBLINS

Designed by Aly Morrison

C36



Falchion

Sniper

Champion

Slaver

Baron Brightgore

Elite



Chain Lasher



Sword



Mace



Great Scimitar

## BATTLECARS

Designed by Tony Slocombe

C42

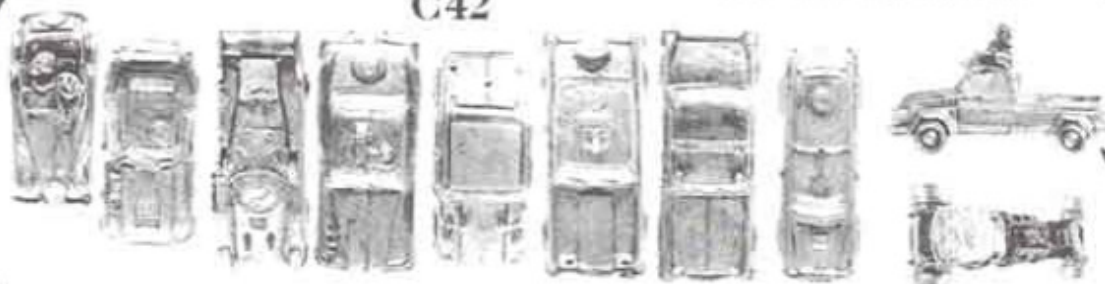

## TOWNSFOLK

Designed by Trish Morrison

C46



Drunk

Baker

Peasant

Traveller

Villager

Busker

Criminal

Falconer



Villager & Child

Villager



Villager

Rat catcher



Beggar

Messenger

Burgher

# Advanced Dungeons & Dragons<sup>®</sup>

## Miniatures



ADD 1 MAGIC USER  
player character pack



ADD 2 FIGHTER WITH LONGSWORD  
player character pack



ADD 3 CLERIC WITH MACE  
player character pack



ADD 5 ILLUSIONIST  
player character pack



ADD 6 PALADIN WITH LONGSWORD  
player character pack



ADD 7 RANGER WITH SWORD & BOW  
player character pack



ADD 8 ASSASSIN WITH DAGGER AND SWORD  
player character pack



ADD 11 FEMALE MAGIC USER  
player character pack

A new concept in role-play models! Each Player Character Pack comprises three versions of the same character, representing the adventurer as a starter character, as an experienced adventurer and, finally, as a fully developed high-level character.



ADD 52 GOBLINS \*



ADD 54 HOBGOBLINS \*



ADD 60 NORKERS \*



ADD 62 SHAMBLING MOUND & SHRIEKER



ADD 72 CARRION CRAWLER



ADD 76 STIRGES  
supplied with clear plastic stands



ADD 75 GORGON



ADD 77 UMBER HULK \*



# Advanced Dungeons & Dragons®

## Miniatures



ADD 80 BLINK DOGS



ADD 86 MINOTAUR \*



ADD 81 OWLBEAR \*



Supplied with a clear plastic stand

ADD 84 BEHOLDER



SHADOW®



ZOMBIE



GHOUL



LICH



WIGHT



GHAST

ADD 93 THE UNDEAD 1 \*

ADD 94 THE UNDEAD 2 \*

DUNGEONS & DRAGONS® and ADVANCED DUNGEONS AND DRAGONS® Miniatures from Wizards are part of the range of ADVANCED DUNGEONS AND DRAGONS® Miniatures produced under a license agreement between TSR, Inc. and Games Workshop Ltd., for use with the DUNGEONS & DRAGONS® ADVENTURE SYSTEM™ and DRAGONS® and DRAGONS® Miniatures. DUNGEONS & DRAGONS® and DRAGONS® are trademarks of TSR, Inc., and all other marks are the trademarks owned by and used under license from TSR, Inc.

®Registered trademark of TSR, Inc. in the U.S.A. and U.K.  
\*Wizards trademarks registered or applied for worldwide by TSR, Inc. See The License Agreement, WIZARDS.COM.

These miniatures are approved by TSR, Inc. for use with the "Dungeons & Dragons" game and under the trademark DUNGEONS & DRAGONS®, DUNGEONS & DRAGONS®, and DRAGONS®.  
©1987 TSR, Inc. All Rights Reserved.

Supplied with random heads \*







# DUNGEONS & DRAGONS®

## Miniatures — STARTER SET 1 —

BDD1 DUNGEON ADVENTURERS STARTER SET



TREASURE CHEST



UNARMoured FIGHTER



DWARF



FIGHTER



THIEF



ELF



CLERIC



MAGIC-USER



ELF

DUNGEONS & DRAGONS® and ADVANCED DUNGEONS AND DRAGONS® Miniatures from TSR are part of the range of ADVANCED DUNGEONS AND DRAGONS® miniatures produced under a license agreement between TSR, Inc. and Games Workshop Ltd., for use with the DUNGEONS & DRAGONS® ADVANCED DUNGEONS AND DRAGONS® and BATTLEMAGIC® games. DUNGEONS & DRAGONS® ADVANCED DUNGEONS AND DRAGONS® BATTLEMAGIC® the TSR logo, and their associated names are trademarks owned by TSR, Inc. under license from TSR, Inc.

TSR, Inc. is a registered trademark of TSR, Inc. in the USA and UK. Advanced Dungeons and Dragons is a registered trademark of TSR, Inc. in the USA, UK, Canada, and Germany. ©1987 TSR, Inc. All rights reserved. These miniatures are approved by TSR, Inc. for the purposes of the 1st edition of the DUNGEONS & DRAGONS® Advanced Dungeons and Dragons® game. ©1987 TSR, Inc. All rights reserved.

## — STARTER SET 2 —

BDD2 DUNGEON MONSTER STARTER SET



GIANT FIRE BEETLES



GIANT RATS



STIRGE™  
Supplied with clear plastic stand



GIANT TOAD



KOBOLD



SKELTON



ORC



GNOLL



BUGBEAR

©1987

# "the Lord of the Rings"™



ME 12 Strider: Aragorn the Ranger



ME 21 Boromir



ME 22 Elrond



ME 24 The Citadel Guard



ME 25 Ithilien Rangers



ME 31 Silvan Elves of Mirkwood



Samwise



Frodo



Bilbo



Merry



Pippin

ME 34 Shire Hobbits



ME 42 Orcs of the White Hand





ME 51 Orcs of the Red Eye



ME 52 Noldor the Deep Elves



ME 62 Saruman the White



ME 64 Black Rider: Nazgul



ME 74 Snagga Goblins



ME 83 Tom Bombadil & Fatty Lumpkin



Citadel's new Lord of the Rings™ miniatures are especially designed to complement games based on the works of J. R. R. Tolkien. They are ideal for use with rôle-play games, such as M.E.R.P., or mass battle games such as Warhammer.



ME 75 Knight of Dol Amroth

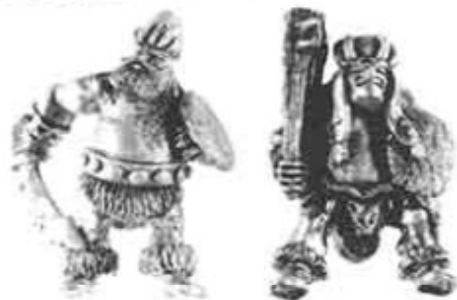

ME 45 Dunlendings



'THE LORD OF THE RINGS' Miniatures are produced under license from Tolkien Enterprises. A division of Elan Merchandising, Inc., Berkley, California, U.S.A.

# WARHAMMER REGIMENTS OF RENOWN

## RR8 GOLGFAG'S OTHER REGIMENT OF MERCENARY OGRES

Designed by Jes Goodwin



Standard bearer



Champion



Chieftain



Trooper



Drummer

## RR16 DISCIPLES OF THE RED REDEMPTION

Designed by Jes Goodwin



Standard bearer



Champion



Disciple



Drummer



Officer

## RR17 AVENGING KNIGHTS OF THE CLEANSING FLAME

Designed by Jes Goodwin



Standard bearer



Officer



Knight



Champion



Horn blower

## RR18 EEZA UGEZOD'S MOTHER CRUSHERS

Designed by Nick Lund



Standard bearer



Officer



Champion



Trooper



Cymbalist

RR 8 contains 4 troopers and 1 personality of your choice

RR16, 17 & 18 contain 8 troopers (Knight or Disciple) and 1 personality of your choice

Nick Lund's  
**chronicle**  
MINIATURES



**GIANT BLACK ORCS**

N11



Masher



Spear



Great Axe



Pole Axe



Hero



Chieftain



Guard



Glaive Killer



Mace



Bowman



**HOBGOBLINS**

N12



Hero



Slicer



Champion



Slasher



Soul Stealer



Mangler



Thruster



Dwarf Maimer



Spearman



Two Hand



Slaver



Skin Eater

# CITADEL MINIATURES

## CHAOS CHIMERA

CM1

Designed by Nick Bibby



Supplied with a selection of 3 heads and a tail.



Coming  
Soon

## DWARF LORDS OF LEGEND

A NEW CITADEL BOXED SET

From the talented hands of Alan & Micheal Perry



King Gorrin



The Baron



Kimril-Giant Slayer



Lastro Lupinthal



Uther



Angus



Throbin Death-Eye



Borax Bloodaxe

See Journal cover for box art

# VESTMENTS of VILENESS

Remember our last competition in which we asked you to design a shield for a warrior of chaos? Well this time all you have to do is summon your imagination and undoubtedly great artistic skills and design our rotting friend here a suitable emblem for his T-shirt. Either draw your design directly onto this page, or take a photocopy and use that. As we may well end up using your design, try to use only two or three basic colours, without any shading or gradation of colours. Yunno the sort of thing. You've all seen T-shirts haven't you?

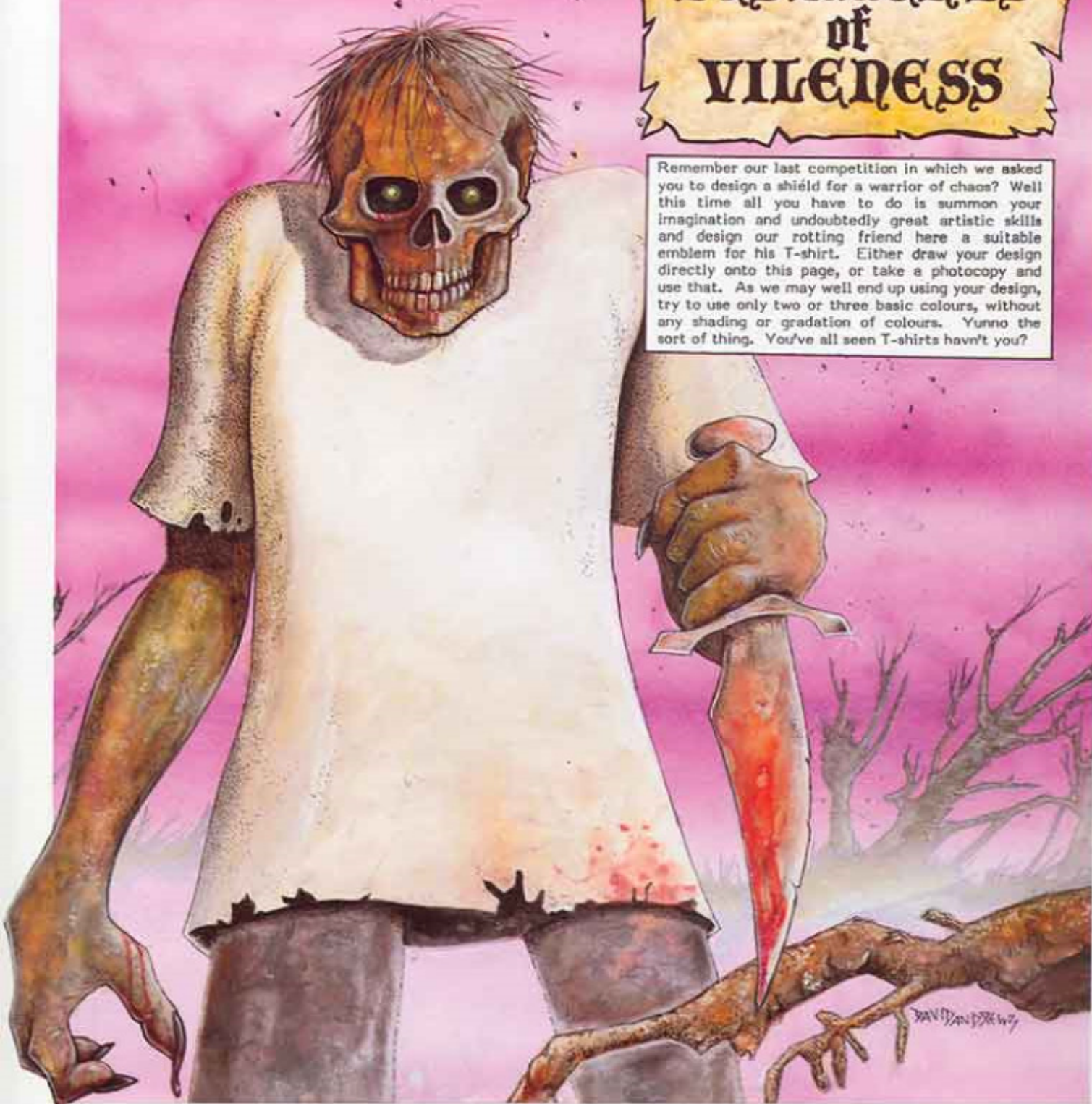

## THE PRIZE!

The winner will receive the supreme accolade of seeing his design appear on a special Citadel T-shirt. They might even get a T-shirt if the Gods of Chaos decide to smile upon their work. Without doubt, we'll also manage to throw in a great big box full of new, shiny and ultimately desirable new models from the Citadel forges. Total value (as if you could even put a price on such unbridled fame) will be well over £50. Enough to keep even a mail order Troll in underarm deodorant for up to a whole week.

Please remember to fill in your entry form, including your name and address and send it to:-

T-SHIRT COMPETITION  
CITADEL MINIATURES  
HILLTOP  
EASTWOOD  
NOTTINGHAM

NAME  
ADDRESS  
AGE

Please send any entries separately, from mail orders or other correspondence. If you mix them up then there is a distinct possibility of either your entry, order or both becoming lost. This is especially true should the mail order troll with the brain cell be round the back worrying mice when the postman comes. Please don't send in lots of little bits of paper with designs on them as this makes Dave ever so mad. Dave decides who wins, so it isn't a very good idea to irritate him.

Enter as many times as you like. We are far too untidy to actually return your entries, please don't bother sending self addressed envelopes, they only confuse Dave. When Dave gets confused he tends to find solace in eating things, so be careful. Entries must be received by 1st December 85. Winners will be notified as soon as possible.

# ARCANE ARMOURIALS



THE WINNER

## ARCANE ARMOURIALS RESULTS

Once again you astounded us by the sheer volume and consistently high quality of entries for our 'Arcane Armourials' shield design competition. After much debate, uncontrolled argument, several fist fights and the death of a mail order troll we decided that the winning entry came from **John Pickering** from Kirkby Stephen in Cumbria. A fine and truly chaotic entry I think you'll agree! A whole heap of the very latest Citadel models are on their way. In addition Dave Andrews has turned John's design into a special trophy - a genuine shield! In the accompanying photo we see Dave using the shield to defend the Citadel factory against an encroaching photographer.

A,B,C LEO HARTAS of HOVE  
 D,E,F DAVID FOSTER of SOUTHPORT  
 G COLIN DIXON of SWANWICK  
 H ADRIAN HELLER of CHEPPENHAM  
 I DARRIN SHAW of SHEFFIELD  
 J GRAHAM GREEN of NEWCROSS  
 K VINCENT DELL of CADSHHEAD  
 L STEPHEN BROWN of ROCHDALE  
 M GRAHAM GREEN of NEWCROSS  
 N SIMON AYRES of SOUTHMINSTER  
 O GERMAN GUILLOT of EALING

P ANGELA-MAY BRONGER of LINCOLN  
 Q ADRIAN HELLER of CHEPPENHAM  
 R ANGELA-MAY BRONGER of LINCOLN  
 S CHRISTOPHER WATSON of STIRLING  
 T ANGELA-MAY BRONGER of LINCOLN  
 U PAUL PICTON of GREAT WIGBOROUGH  
 V KIAN GAXTON of SNEFN MOOR  
 W DAVID DRURY of STOCKTON ON TEES  
 X GRAHAM COURTEY of MEXBOROUGH  
 Y COLIN DUNOGHUE of WARE

All runners up have received a £5 Citadel Credit voucher.





# THE RUNNERS UP



# Giants, Titans & Giant Demons

## On A Budget

Do I hear ariight? Did somebody say Giant Demons on a Budgie? Another Tony Ackland model perhaps? Sorry, nothing so grandiose, merely a useful application of Citadel's new plastic models in Warhammer. Well didn't you say, 'I'm never paying over five quid for a Giant, never, not ever, no how?' Yea it is true, large metal models are pricey. This is so for a variety of reasons - most of which are blindingly obvious and unworthy of even so much as a mention. But, with Citadel's new plastic 60mm models, anyone with an iota of modelling talent and but a single brain cell can put together whole regiments of large humanoid creatures that look absolutely great! They also make splendid leaders of normal sized creatures. And, at 65p each, I don't think anyone can really complain about the price either.



Titan in combat with Sentinel of Chaos

# Mountain Giants

The plastic barbarians make ideal nordic type giants - no messing, no converting, straight up. Sometimes life can appear blissfully simple.

**Physique.** Mountain giants grow up to 14' tall (that's about 60mm high). They are very muscular and strong, being used to the cold and forbidding climates of the mountains. Skin colour is the same as humans, hair is usually fair or reddish.

**World Distribution.** A few Mountain Giants live amongst the Worlds Edge Mountains and the Mountains of Mourn, but by far the largest communities are in the Northlands, especially the mountainous heartlands of Norsca.

**Alignment.** Neutral.

**Special Rules.** Cause fear in troops under 10' tall. May throw rocks up to 14" causing strength 7 hits. Troops under 10' tall attacking a Giant suffer a -1 to hit unless armed with pole weapons. Mountain Giants are cleverer than most, and so are **not** subject to stupidity. They are subject to **alcoholism**.

**Profile.**

M	WS	BS	S	T	W	I	A	Ld	Int	CI	WP
6	3	3	8	7	6	2	5	6	6	6	6

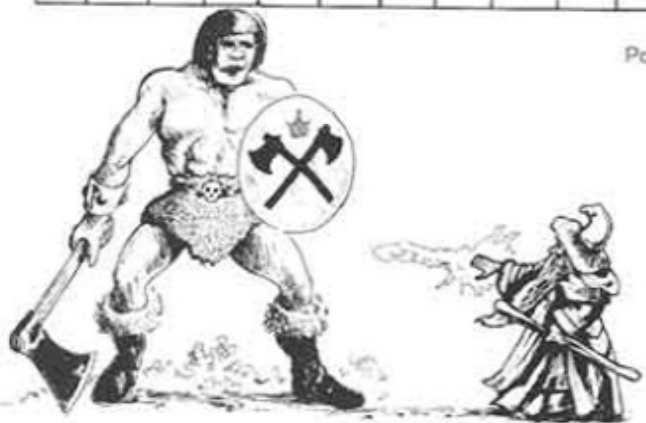

Points-225

# Sentinels of Chaos

Sentinels of Chaos are giant Chaos Warriors and can be created easily using the Chaos Warrior plastic models. Sentinels of Chaos are amongst the most powerful of all the servants of the strange and terrible Chaos Gods. These giant warriors stand as eternal guardians on the dimensional gateways that lead into the dominions of the Gods of Chaos. Occasionally a Chaos God might decide to send a Sentinel into the world to wreak havoc and carnage in the name of Chaos. So it is that these huge and fearsome warriors sometimes appear as part of Chaos armies and raiding forces.

**Physique.** Sentinels of Chaos look like giant Chaos Warriors. Handy isn't it?

**World Distribution.** Sentinels never stay within the world for long. As they always appear from the polar regions, as part of the incursions of Chaos, they are usually active only in the northern and southern parts of the world - and then mostly only in the north. However, the Gods of Chaos are powerful beyond measure, and might easily transport one of their servants anywhere within the world at a whim.

**Alignment.** Chaos.

**Special Rules.** Cause fear in troops under 10' tall. May throw rocks up to 14" causing strength 7 hits. Troops under 10' tall attacking a Giant suffer a -1 to hit unless armed with pole weapons. Sentinels are not subject to stupidity, but they are subject to **instability**. Sentinels also have magic powers and can employ either a fire ball or wind blast spell. They can do this once per turn without concerning themselves with magic constitution points or rolling for success. There is a 25% chance of a sentinel carrying a randomly generated runeweapon with D6 runes.

Sentinels are immune to the effects of fear and terror unless caused by the gods themselves.

**Profile.**

M	WS	BS	S	T	W	I	A	Ld	Int	CI	WP
6	4	4	7	7	6	3	5	10	10	10	10

Points-245



# Titans

Titans are the Lawful equivalent to Sentinels, and are also called Sentinels of Law. Their role is as guardians of the dimensional gateways that lead to the dominions of the Gods of Law, and as agents of those divine and humourless powers. Titans can be represented by the plastic Knights of Law. You guessed!

**Physique.** Perfect, hunky and radiant.

**World Distribution.** Titans appear in the world as messengers and agents of the gods, and might easily appear anywhere. As the natural adversaries of the Sentinels of Chaos they often appear to counter these terrible chaotic forces. A fight between a Sentinel and a Titan is a terrible thing to behold, for neither creature will give in until the other is slain.

**Alignment.** Law.

**Special Rules.** Cause fear in troops under 10' tall. May throw rocks up to 14" causing strength 7 hits. Troops under 10' tall attacking a Giant suffer a -1 to hit unless armed with pole weapons. Titans are not subject to stupidity, but they are subject to **instability**. Titans have no magical powers, but are immune to all magic themselves, even beneficial magic such as healing spells. They are not immune to magic weapons. There is a 25% chance of a Titan bearing a magic weapon with D6 random attributes. Titans are immune to the effects of fear and terror unless caused by the gods themselves.

**Profile.**

M	WS	BS	S	T	W	I	A	Ld	Int	CI	WP
6	4	4	7	7	6	3	5	10	10	10	10

Points-245



# Evil Demons

You can make a variety of Evil Greater Demon types using the plastic Orcs and Skeletons, as well as by swapping round elements from other models. Without doing any modelling the Orcs look great just painted up and placed at the head of their smaller metal counterparts. Experienced modellers might like to have a bash at wings, horns and tails.

**Physique.** Giant Demons may appear up to 18" high (80mm) if Orc based, or less if based on some other creature. The profiles are not dependant on height with these supernatural creatures. Colours and other details are up to you!

**Alignment.** Evil.

**Special Rules.** Cause fear and terror in all living creatures. Immune to psychological effects (unless caused by Gods), cannot be routed (except by Gods). They are immune to normal weapons. All attacks count as magical - as if they were magic weapons. Subject to instability. They can be given magical powers on the same basis as a Balrog.

## Profile.

M	WS	BS	S	T	W	I	A	Ld	Int	CI	WP
6	10	10	7	7	15	10	10	10	10	10	10

Points-1188



# Evil Giants

Suitable Evil Giants are provided in the form of the plastic Goblins. Conversion is not really necessary, but you might like to give your Giant a club or axe to make him look more 'giantish'. Why Giants should have this preoccupation with bludgeoning instruments I don't know. Possibly it is something to do with the satisfying squelching noise produced when they pulp something.

**Physique.** An Evil Giant can grow up to 14' tall. Skin colour is goblin-like, greenish and unpleasant. Hair, where present, is black.

**World Distribution.** Mostly confined to the Giantlands of Norsca, although a few individuals live amongst the World's Edge Mountains and Mountains of Mourn.

**Alignment.** Evil.

**Special Rules.** Cause fear in troops under 10' tall. May throw rocks up to 14" causing strength 7 hits. Troops under 10' tall attacking a Giant suffer a -1 to hit unless armed with pole weapons. Evil Giants are subject to stupidity and alcoholism.

## Profile.

M	WS	BS	S	T	W	I	A	Ld	Int	CI	WP
6	3	3	7	7	6	2	5	6	4	6	6

Points-215



# The Colossi of Azram the Mighty

The Colossi were created by the Dwarf God Azram the Mighty, Lord of the Stone and Heart of the Mountain. Each took the form of a giant Dwarf, but instead of flesh and blood they were made from living rock. These agents of the god dwell inside the mountain, within the rock itself, and rarely appear except in times of great need. At the last, great, underground city of the Dwarfs, Caraz-A-Carak (known to men as Everpeak) four mighty colossi stand by the main entrances, two on the west gate and two on the east gate. They do not move, but legend has it that should the need arise they will come to life and protect the city.

**Physique.** Take a plastic Dwarf and paint it grey to represent stone. A darker grey wash will bring out the detail. To make the stone look weathered dry brush in white or pale grey, and apply washes of white and pale green in patches. This will give the appearance of weathering and lichen. Then, with a fine brush or a fibre tipped pen, draw on the cracks and fissures wrought by time.

**Alignment.** Neutral.

**Special Rules.** Cause fear and terror in all living creatures. Immune to psychological effects (unless caused by Gods), cannot be routed (except by Gods). They are immune to normal weapons and all normal magic. They are not immune to magic weapons. All attacks count as magical - as if they were magic weapons.

## Profile.

M	WS	BS	S	T	W	I	A	Ld	Int	CI	WP
6	4	4	7	7	6	3	5	10	10	10	10

Points-245





# A FISTFULL OF FIGURES



## THE PLAYER'S GUILD

Once upon a time, during the Dungeon and Dragons revolution, there were a number of wargamers who discovered role-playing. Unfortunately it didn't stop there. This small band of rogues, numbering five in total, decided that in a small way they could gain fame, fortune and power. The Players' Guild was born!

After much thought and discussion we agreed to start our task of world domination by building a 6' x 4' display/demonstration wargames board. Using our own unbelievably fantastic medieval siege rules we played a scenario with a small city being demolished and its subsequent assault. This board was built from polystyrene and other household rubbish and was something of a new concept in display games (gasp).



The display game (as we call them) was first shown at the National Wargames Championships in Nottingham in 1983. To add to the overall effect we dressed up as demoted 13th century brigands and promptly received the Best Demonstration Game trophy for our efforts. Much interest was shown by the public as well as by a BBC Radio Nottingham interviewer (which really showed our display off to its best advantage!).

Citadel Miniatures also showed a demonstration game at the same time and we suffered constant interrogation by (unknown to us) the Citadel staff. (You also suffered a constant stream of elastic bands and bottle tops ... bet you didn't know that was us did you -ho ho...Ed).

After freely discussing our arcane secrets with Bryan Ansell, Rick Priestley and everyone else that would listen, we were un-nerved to find out who they really were! Citadel returned to Newark obviously despondent that such an amazing display could be produced by a bunch of amateurs. Bryan Ansell, seething with anger, jealousy and despair, no doubt tortured his own inadequate display team long into the night. (Enough of this slimy drivel - get on with the article Howes - Ed).

Anyhow, flushed with our victory we characteristically discussed it and then sat down upon our haunches to await the success that would undoubtedly come knocking on our door. It hadn't appeared after three months and the display game was rotting in a mouldy caravan at the bottom of our garden.

Then the idea came! We could approach the moguls of Citadel and explain how we could make games to display Citadel models. The subsequent interview was an epic one. The three man delegation pulled up in their wagon outside the Newark factory, climbed the electrified fence, fought off the blood-crazed guard dogs and were promptly caught and thrown into a dungeon by a couple of burly tea-ladies. We were disarmed, stripped, bathed, deloused, perfumed



and dressed before being instructed how to behave properly in Mr Ansell's presence. Nerves at breaking point, we waited in an anti-room. We were announced, ushered in and then prostrated ourselves on the floor whilst singing 'three blind mice'. At the appointed signal I stood and gave a brief two hour long resume on how Citadel couldn't do without us. A quiet hush filled the throne room. I could see that Mr Ansell was impressed as he was frantically giving directions on how I should be dismembered. Fortunately, at this point Rick Priestley appeared, and I breathed a sigh of relief as a discussion was held and a contract was hastily drawn up. As we were about to have our wrists slashed so that the document could be signed in the traditional manner I suddenly asked, 'But - what of our price?'. I could see that Mr Ansell was impressed, and the contract was reglued back together, and a sub-clause added. Our price would be ... A Fistfull of Citadel Figures.

Our wagon, now laden with three tons of cast white metal, ponderously wound its way back to Mansfield. The victory celebration lasted long into the following hour.

## A FEW FIGURES MORE

For the past two years we have shown our display games all round the country at many wargames and fantasy conventions. We have received many trophies and appraising glances. We currently appear at most Citadel/Games Workshop conventions and try to show a different display at each one. We like to think that we bring a few extra people into the world of role-playing and wargames: people that wouldn't have bothered if left to watch arguments, with boringly painted metal blobs on a board of cardboard-box houses, flat felt representing woods and blue chalked rivers.

We make our displays as good and as colourful as we can, but always with an eye to practicality. All of our games come apart, and feature items that we can use in our own wargames at home. We also use materials and tools that are **not** specialised and so are available to anybody.

The figures are all painted by ourselves - we think to a reasonably high standard. We also try to show possible conversions of standard models, and new innovations such as our Dwarfven hang-gliders!. These are simple to build and fun to use. Basically - anybody can build and paint the displays seen - believe me.

## ARCANE SECRETS AND METHODS

Our arcane secrets are not secret any longer. What follows are a few tips and suggestions that you may wish to utilise when building either terrain features or display boards of your own. We would not for one minute suggest that you go out, buy a 6' x 4' sheet of polystyrene and get cracking with a large knife, pot of plaster, glue and tins of paint - especially not on your best carpet. Wargames boards, such as can be used for Warhammer, can be built in small, easily stored sections and are relatively easy and clean to construct.

Firstly - a note of warning. If you wish to follow any of our suggestions then make sure that you are adequately prepared. Cutting polystyrene is extremely messy, it gets everywhere and is best done out of doors. Also, if you are using plaster/poly-filler or even large amounts of paint then you'll need newspaper around the work area and underneath the polystyrene (it's porous).

Consider your needs. If you have only a small playing area then you might find the 1' x 1' ceiling tiles an ideal base. For larger areas, and larger terrain features, 2' x 1' or 2' x 2' pieces can be built. See fig. 1.

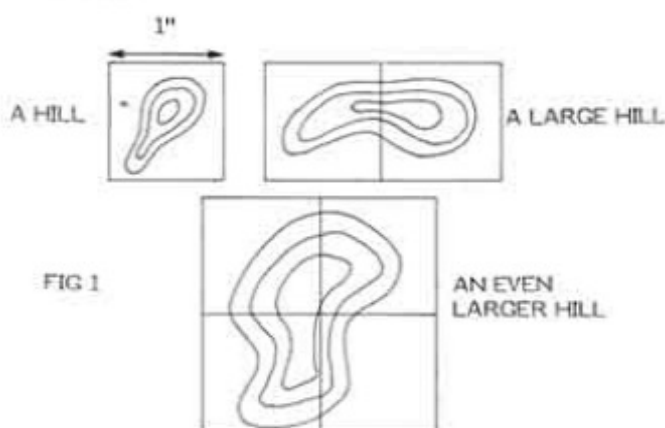

Armed with a packet of ceiling tiles let us get to work. Polystyrene, however thick, is damaged fairly easily, so the underside of the tile needs to be strengthened. Thick card or thin hardboard can be used depending upon your budget. You will need to glue the card or wood with either white wood glue or another suitable adhesive. Many types of glue will melt the polystyrene. Leave glue to set overnight before working further.

Next you must decide what sort of terrain you require. Remember that boards should be geomorphic - that is, they must fit together. To this end the last inch around the edge of the tile should be left flat. See fig. 2.

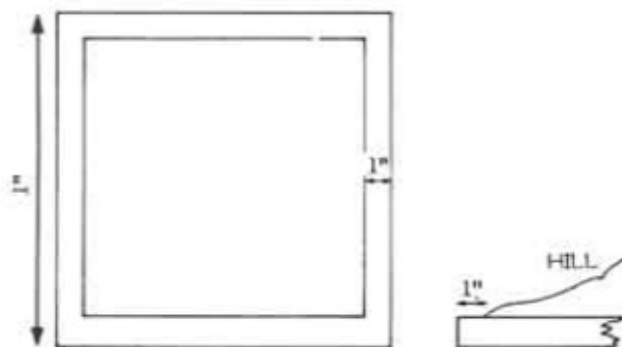

Also bear in mind that you have to be able to move figures around on the boards, so your woods can't be too thick or the hills too steep.

If you want water features, then unless you've got a large number of tiles (to swop around) keep the water area small, say 3 or 4 river sections and a pond or swamp. Always keep your terrain simple. Hedges, walls, houses, bridges, etc can be built separately and placed on top of the boards.

A note on types of paint. We use water-based poster, acrylic and emulsions. They can all be diluted and very little paint is used considering the area covered. Obviously if you possess an air-brush then this is the best method. However, most of us do not, and so a 1" household paint brush, a 1/2" brush, a small (number 2 or 3) brush and a mixing dish for paint will be needed.

#### GRASS AND FLAT

If you have a 6' x 4' playing area then you will need 24 1' x 1' tiles. We recommend that at least half of them are flat sections.

You can paint colour directly onto the polystyrene, or you can adopt one of the following texturing routines.

1. Cover the tile with a thin layer of white glue and sprinkle dry sand over it before it sets. Once thoroughly dry, brush off the surplus sand and paint the tile with a medium green (assuming we are dealing with grass). Once the green has dried, dry-brush the board with yellow or light-green. This is a technique of applying a thin, nearly dry coat of paint, just lightly running the brush over the area so that the paint adheres to the raised surface detail. This gives a feeling of depth. See Gary Chalk and Joe Dever's article in White Dwarf 61.

2. The section is covered in white glue and sprinkled with railway modellers' flock. This is more expensive than the first method. The board must be painted with a dark colour **before** applying the glue and flock, otherwise the white tile will show through producing a bleached appearance. If you use this method then vary the colours of the flock to give lighter and darker patches.

3. This is by far the most expensive and difficult method, but it is the one we use for our own displays and will give you the best finish. Large sheets of ready made grass can be bought at railway modellers' shops. These are covered with a layer of stand up nylon fibres. It feels a little like short fur and makes the figures stand out beautifully. However, it must be applied in sheets or strips, and unless the area is flat it will require a lot of cutting and shaping to fit. White glue is used to stick the grass into place - and no small amount at that! If you skimp the grass forms into bumps and wrinkles that cannot be camouflaged easily.

Whichever method you adopt, lichen, bought from model shops, will cover up mistakes or white patches. Cork can be used to make outcrops of rock, which will make the surface more interesting.

#### HILLS

Hills are made by cutting circular or oval shapes out of polystyrene tiles in the succeeding smaller circles. See fig. 3.

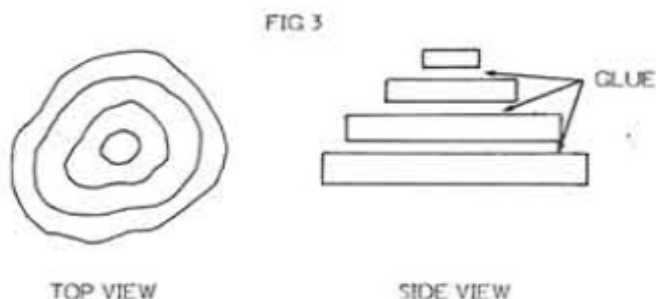

These are then glued together, and, using a bread knife, shaped to a gentle slope. See fig 4.

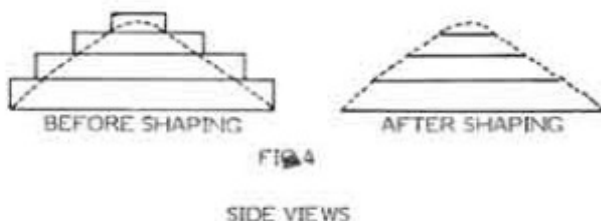

Kidney shaped and saddle hills can also be made and cliff/rock faces for the adventurous among you. Hill are covered in the same way as before for flat sections.

#### WOODS

Trees may be stuck onto existing flat/hill sections or put onto separate bases and placed on afterwards. There is no easy way to make trees, and unless you are really committed then we suggest that you buy them from your model shop. We find that the ones that stand about 5" tall made out of wire brushes and covered in green flock are the best. They retail around £1.50 each. However, if you want a forest, then cheaper trees are available. If you want to make your own then, quite honestly, I would go to the library and borrow a book on railway modelling techniques. This would help you far more than our efforts in tree making!

## RIVERS

River sections, as said before, should be small in number. Too many rivers tends to fragment the action during play, or constricts the action to bridges and fords. Rivers should start and finish in the centre of any two sides so that when placed together they form a continuous line. See fig. 5.

POINT A IS 6" ALONG EDGE OF BOARDS

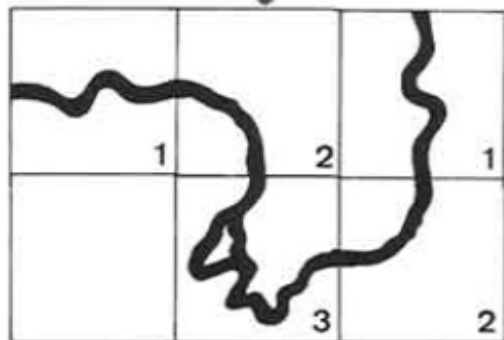
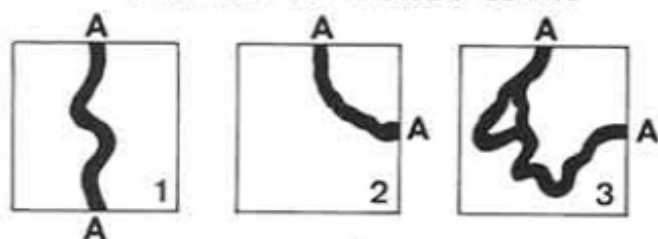

FIG 5

WHEN PLACED END TO END IN DIFFERENT WAYS

They are made by gouging out the polystyrene with a bread knife so as to form a channel. Plaster or polyfiller is then poured along the length of the channel up to about half of its depth. It is then left to dry. Brush plaster onto the banks as well. The remainder of the tile is then grassed etc as before and the river banks painted. Paint up to and over the sides of the river banks with a muddy brown colour and dry-brush with light brown. When dry, paint in the water with a smaller brush and a dark blue colour. If your river is wide then slightly darken the colour at the centre going lighter towards the banks. Then dry brush with light blue and dry brush again with white for foam flecked or fast running streams. Note - fast running water can be highlighted by placing rocks in the river itself and painting in breakwaters in the direction of the flow. See fig. 6.

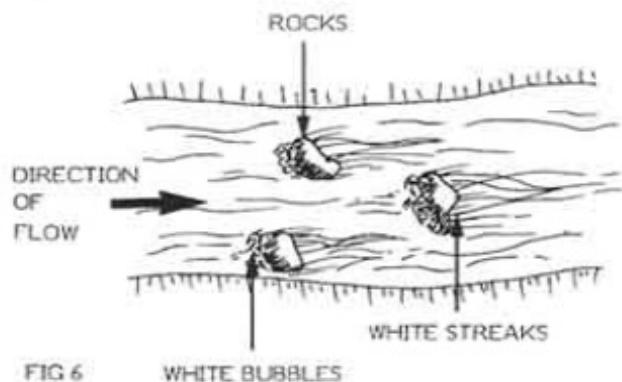

FIG 6

WHITE BUBBLES

After the paint is dry, varnish the water with gloss varnish. We have found Ronseal wood varnish gives a nice finish, it is also reasonably cheap and lasts ages. Lichen and rocks may be added as before in clumps and clusters onto the river banks.



## PONDS/LAKES

Ponds and lakes are made in the same basic way as are rivers. They are usually greener in colour than rivers because of the algae, and have more bushes and trees growing around them. Add brown to the colour mix for stagnant ponds and a small amount of yellow for clear spring types.

## SWAMPS

Swamps look best next to some sort of water area. Mix a pot of fairly thick polyfiller and apply to the region you want as a swamp. While this is still wet sprinkle on bits of dry sand and push in pieces of lichen, dry roots and twigs. Paint with dark brown, and don't worry too much about painting the lichen, etc. Dry brush the area with green and then lighter shades. A few more dry roots, etc. can be added to taste. The swamp area can then be varnished. Swamps can have wet and dry patches - so apply your varnish patchily to represent this.

## SAND/ROCK

Areas of sand and rocks, and other desolate areas can be made by plastering the area and adding small stone chippings or pieces of cork glued into place. Paint rocks black or dark grey, dry brush white with yellow ochre, light grey and finally white.

## ROADS/TRACKS

These may be built onto the board - but the best way of making roads is just to use hedges and wall sections as road boundaries.

## OTHER TERRAIN

Statues, standing stones, walls etc can all be made from self hardening clay - such as DAS. Buildings offer the greatest challenge, and are far beyond the scope of this article. Briefly they can be constructed from card and balsa wood, and if covered with a thin layer of plaster will present a really solid stone effect.

Never be afraid to experiment - some of our best results have come from doubtful ideas, and the suggestions given all stem from trial and error. We like to think that our display games demonstrate what is possible with a little thought and a few simple skills.

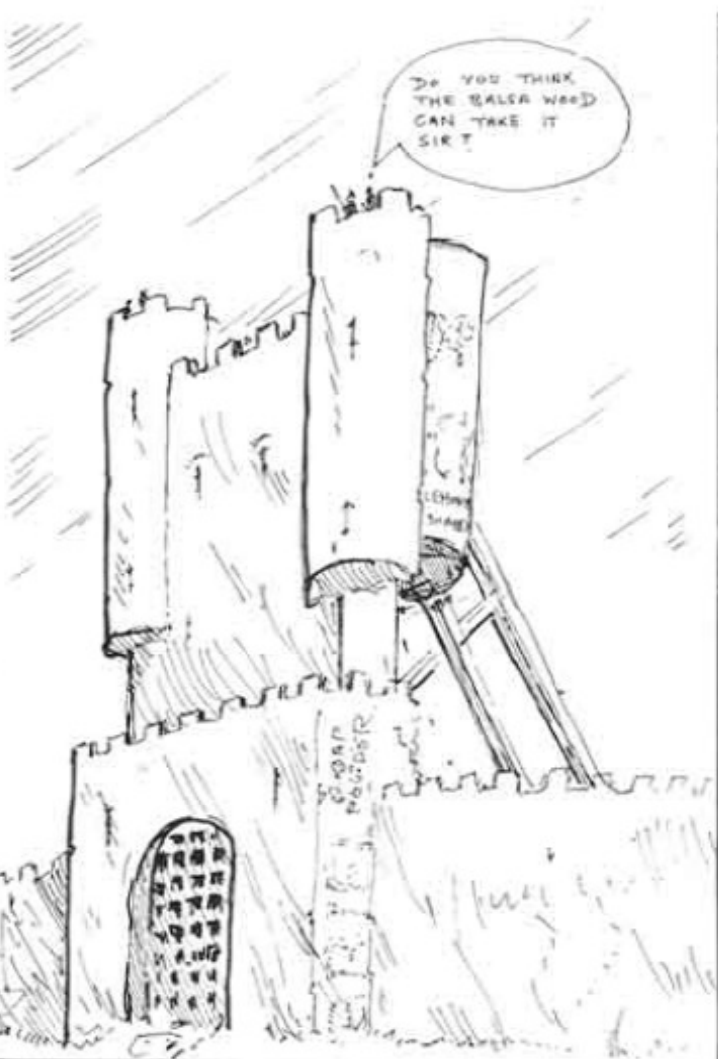



# RICK PRIESTLEY —GOES— IN PURSUIT



Every now and then we drag out the unwilling goblins, orcs, chaotics, and wandering vacuum cleaner salesmen for a good bashing a la Warhammer. Now I enjoy a thorough stomp - preferably as the insane and sadistic leader of a bunch of tatty goblins or wolf-riders. Sadly this never seems to happen....always, always, always I end up as the gamesmaster (I prefer the term 'omnipotent one' at such times). Being the GM (or OO in this case) is O.K., but I miss the opportunity to inflict carnage (especially on that great Chaos Lord Bryan Ansell who almost certainly deserves it). But, worst of all, worst than anything you can imagine, worst even than a dinner date with Tony Ackland, is the incessant whining and wingeing perpetrated by the opposing commanders as their favourite units vanish in a miasma of blood, are pured out of combat or just run off and hide in trees. At such times despondant commanders make a desperate lunge for the rule books, tearing page after page in a pitiful attempt to find some loop-hole that will save their bacon. The smell of burnt gammon firmly in his nostrils, the by now shrieking commander invariably takes unquiet solace in pointing out what he perceives to be an unfair or discriminatory rule. Mostly this is just sour grapes, and what with all these sour grapes and gammon around we usually get hungry at this time and disappear off to the curry house via the pub. Thus esconced my fellow players and I indulge in a running debate on whatever rule it was that caused the problem. It is truly amazing how eight beers and a curry can solve almost anything. Or was it a beer and eight curries? Anyhow, on the occasion I have in mind it certainly worked, and that is what this short and not very to the point article is about. You were beginning to wonder weren't you?

The rule in question concerns pursuit. This is described in the Warhammer (second edition) Combat book on page 27. If you have a copy of Warhammer, and if you're at all interested in this dead fascinating and thoroughly educational rules rap, then I suggest you read through this section again now. What happens when a unit routs is represented in the series of diagrams below. Imagine it is player A's turn and he charges his unit against player B as shown in diagram 1. The two units fight a round of combat as shown in

diagram 2, player A suffers no casualties, player B suffers 4 casualties, is forced to take a rout test, fails this and is routed. The now routing unit B is instantly moved 4" away from unit A in accordance with the rules. Player A decides to pursue, and so unit A is also moved 4" and remains in contact behind unit B. The situation is now as in diagram 3. So far so good. That is the end of player A's turn with total victory achieved and the enemy firmly on the run. It is now player B's turn and unit B is moved at double rate away from the pursuers. As the two units are now out of contact there is no subsequent combat and the pursuit has been effectively ended. Unit B may attempt to rally at the end of the turn. Unit A becomes **confused** until the end of their own next turn. The situation is now as in diagram 4.

So unit A is now effectively stranded, without causing any additional damage on the routing unit. I think player A might at least fairly expect to be able to further pursue his enemy, causing more damage and mangling player B in a satisfying manner. The situation seems even more unfair if you consider what would have happened if unit B had routed unit A. What would have happened is as follows. In player A's turn unit A charges unit B as in diagram 1. A round of combat is fought and player B suffers no casualties, but player A suffers 4 casualties, fails the subsequent rout test and is routed. Unit A is moved 4" away from combat, and unit B is moved 4" in pursuit. It is now the end of player A's turn and the situation is shown in diagram 5. It is now player B's turn. Unit B cannot move because of the presence of unit A, so both units remain stationary and a round of combat is fought. During combat unit B causes sufficient casualties to wipe out unit A totally - unit A counting as routed on the combat table, and losing the protection of shields.

Seems unfair doesn't it? In many ways unit A would be better off not to enter combat but to wait until charged. Of course, charging does confer a beneficial 'to hit' modifier (more so for some weapons, such as lances), but even so it would be better for the chargers not to rout their enemy during the first turn. It would be far better to rout the enemy in the following turn (the enemy's

Diagram 1

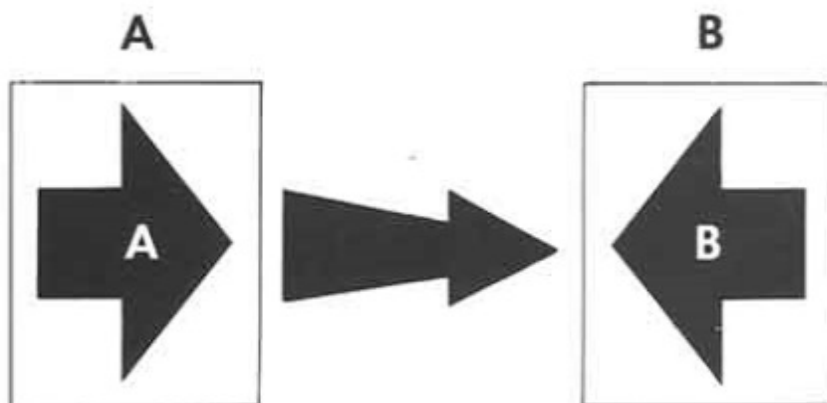

2

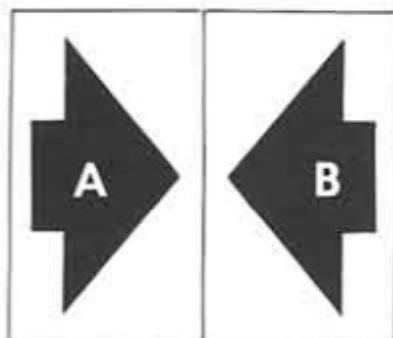



turn) so that during pursuit it is the pursuers own turn, and the routers cannot get away.

So as they stand the rules do not allow for the situation where a body of fast, well armed and mobile troops (such as cavalry lancers) routs a slower, more clumsy enemy, and then pursues them utterly into the ground. Obviously this is not a good thing - anything that gets in the way of slaughter, death and carnage cannot be a good thing. So, when my wingeing commanders pointed out the need for a new rule on pursuit I had to agree. I had to agree because I'd already suffered being beaten around the head with a half eaten chapati, and someone was reaching purposefully for the Chicken Vindaloo.

The new rule allows for pursuers to continue moving as the routers move - during the router's own turn. Pursuers move at double rate, the same as chargers. To continue pursuit in this way the pursuers must be able to move at least as quickly as the routers. If they cannot do so then the rules apply as before.

As routers move away from pursuers during their turn the pursuers have the option of continuing the pursuit or not. If the player decides not to pursue then he must test against his leadership and if successful the pursuers are halted and become **confused** until the end of their next turn - as in **Pursuers** para. 4 and 5 on page 27. If

the player fails to successfully halt a pursuit or if the player decides to pursue then the pursuers are instantly moved forward into contact and a round of combat is fought as normal. Once involved in a pursuit, troops move only during the router's turn until they are halted either by a successful leadership test as described, or by reason of the enemy being totally destroyed. Once routers are totally destroyed pursuers must halt instantly, becoming confused until the end of their next turn. Pursuers may be charged by fresh enemy during a pursuit - move the pursuers first and then the chargers. Pursuers charged in this way become **confused** and remain so for the duration of the combat, until they are routed or rout their enemy. If confused troops rout their enemy they must halt, and will remain confused until the end of their next turn.

The implications of this new rule are that it becomes more difficult to actually stop a unit pursuing, especially fast units with poor leadership - such as goblin wolf riders. This is good in a way, because it simulates their lack of discipline and love of needless slaughter! Routing also becomes more dangerous, especially for infantry and other slow troops. It is very easy for a unit to be wiped out during a rout. The new rule also introduces the possibilities of using reserve units to catch over enthusiastic pursuers. ■

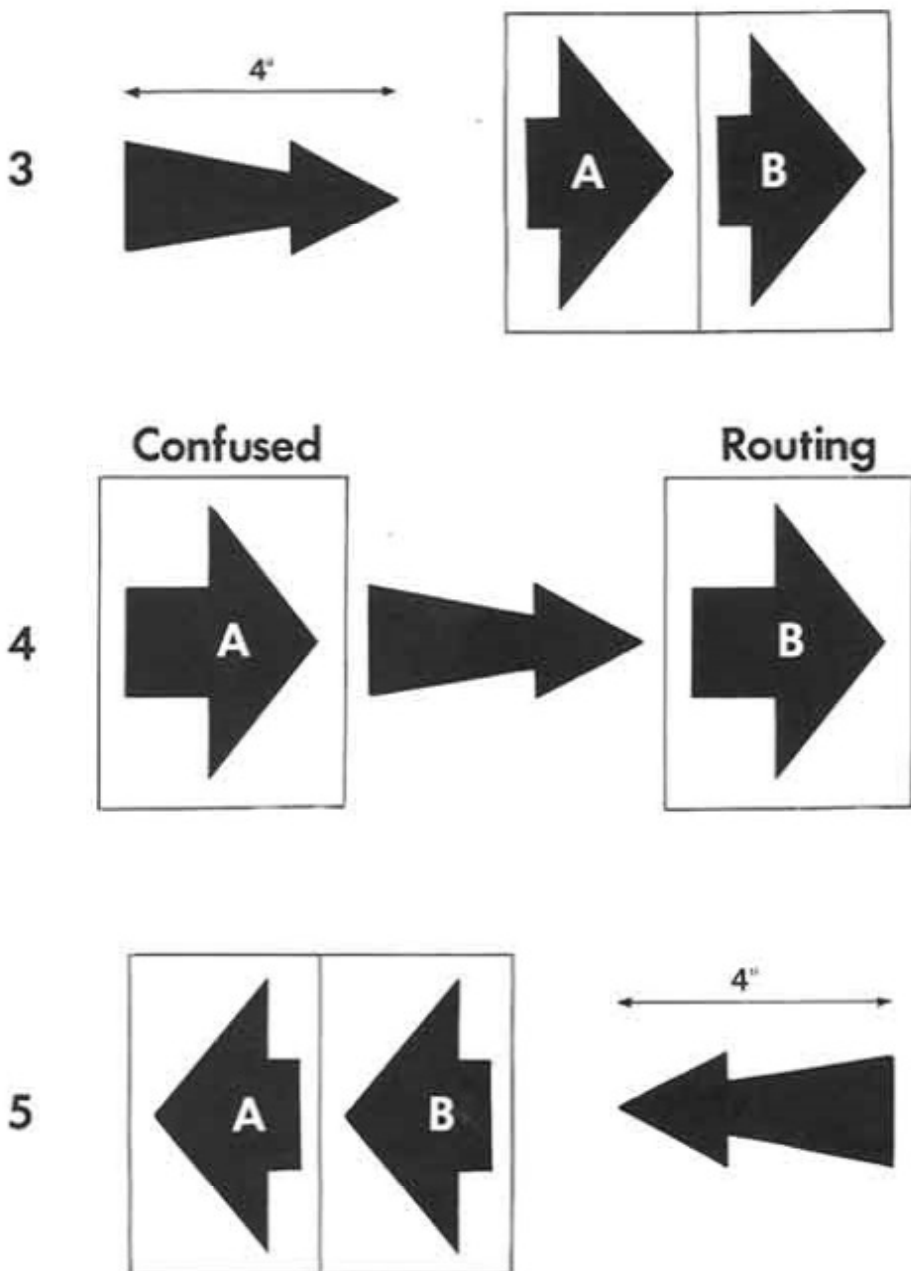

WARRIORS

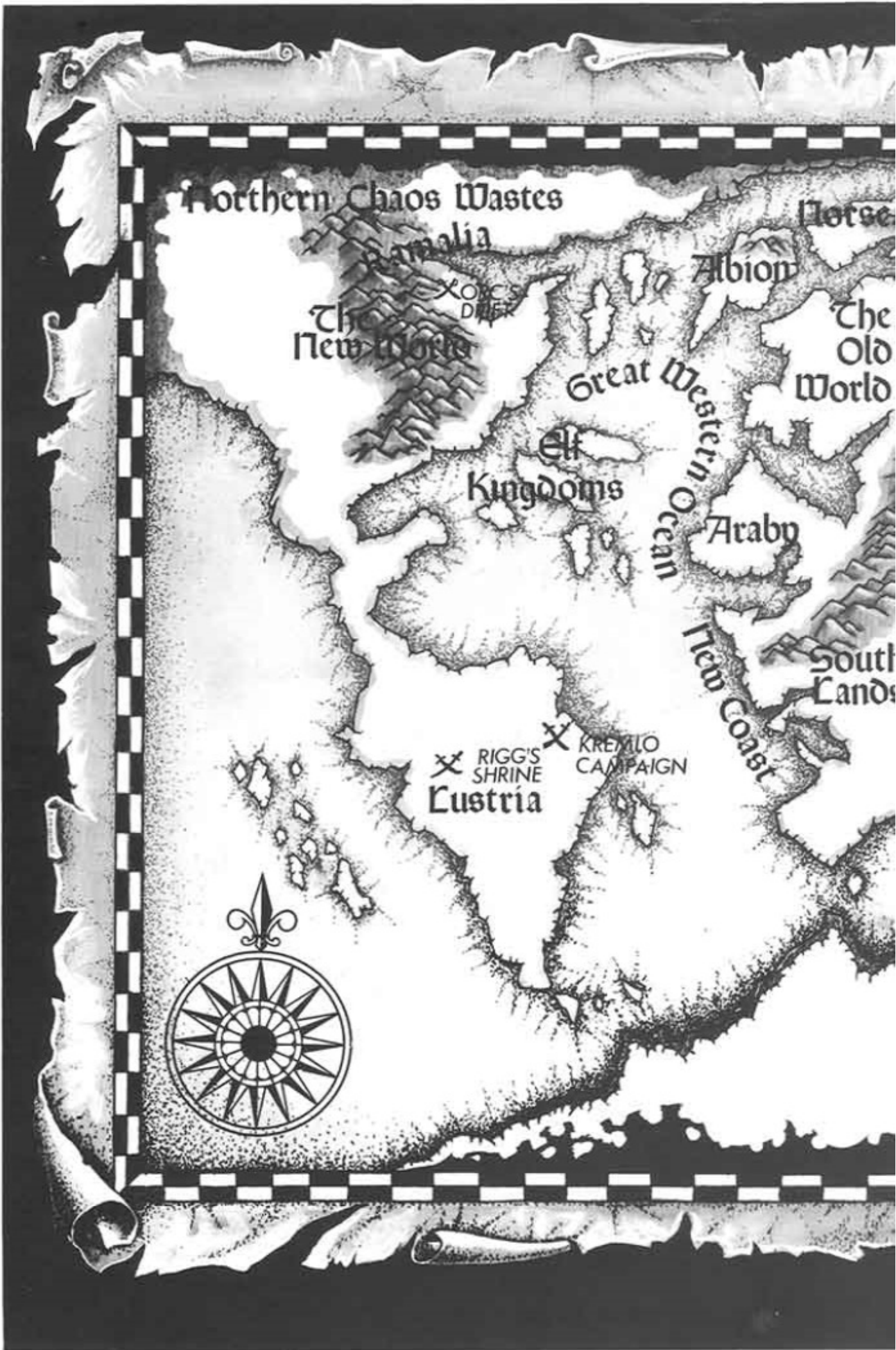

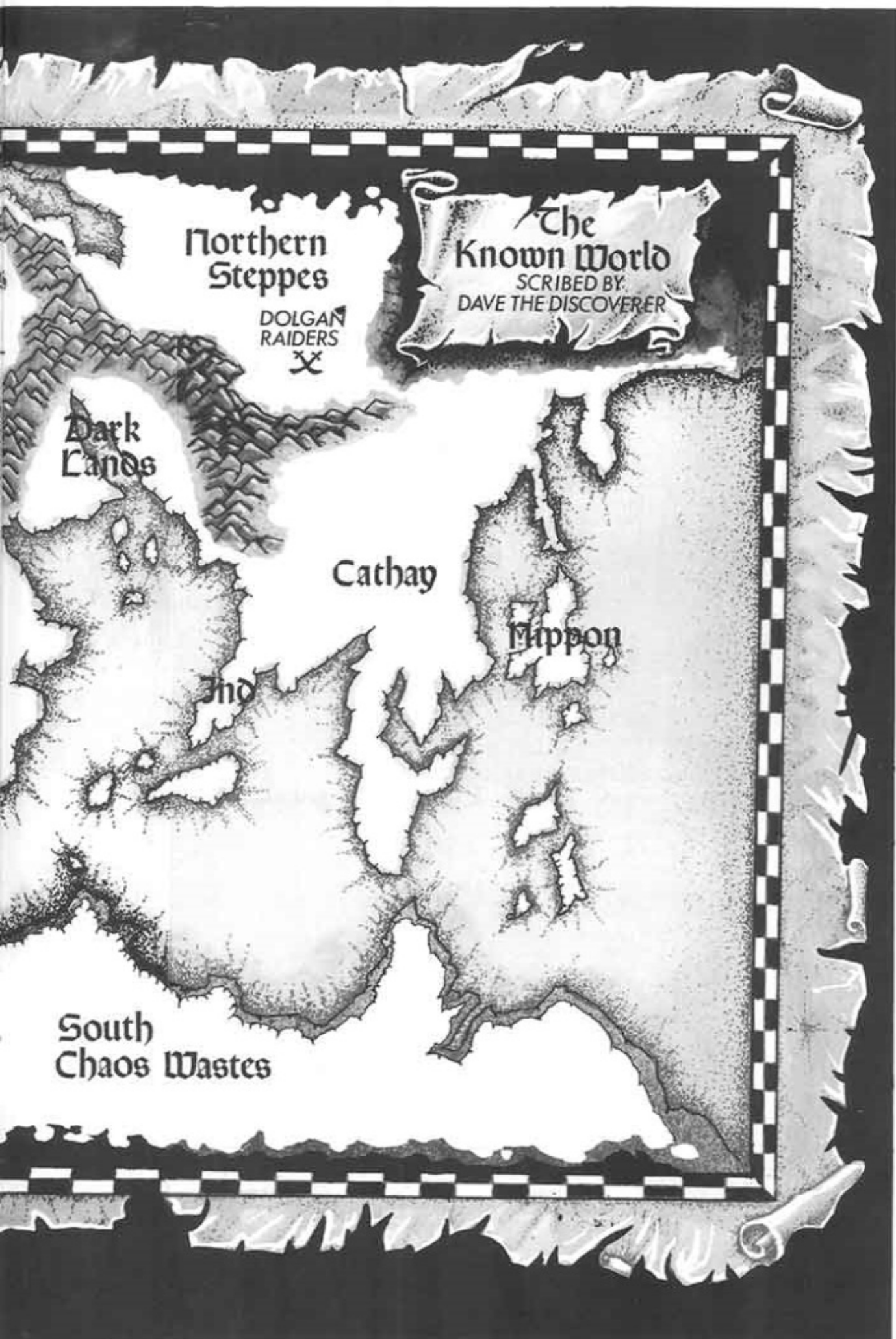

Northern Steppes

DOLGAN  
RAIDERS  
X

Dark  
Lands

Cathay

Mippon

Ind

South  
Chaos Wastes

WARHAMMER

# READERS ART GALLERY

We are always pleased to receive artwork from readers of the Citadel Journal, whether presented as an idea for a new creature or just an illustration of a favourite character or scene. These pictures are just a small selection of the many drawings we receive every week. If you would like to send us a picture of your own, make a drawing in black ink only and mail it to Citadel. Remember to include a stamped self-addressed envelope if you would like your artwork returning.

We're writing 25 Citadel Yearners to all of the contributing artists featured below. We'll also send a 25 voucher to anyone who has artwork printed in a future Journal or Compendium - so get drawing.



JENS ANDERSON  
BODEN  
SWEDEN



DAVID FOSTER  
SOUTHPORT  
MERSEYSIDE



MICHAEL KINDON  
MILFORD HAVEN  
DYFED  
WALES



SEMUS DOHERTY  
CREWE  
CHESHIRE

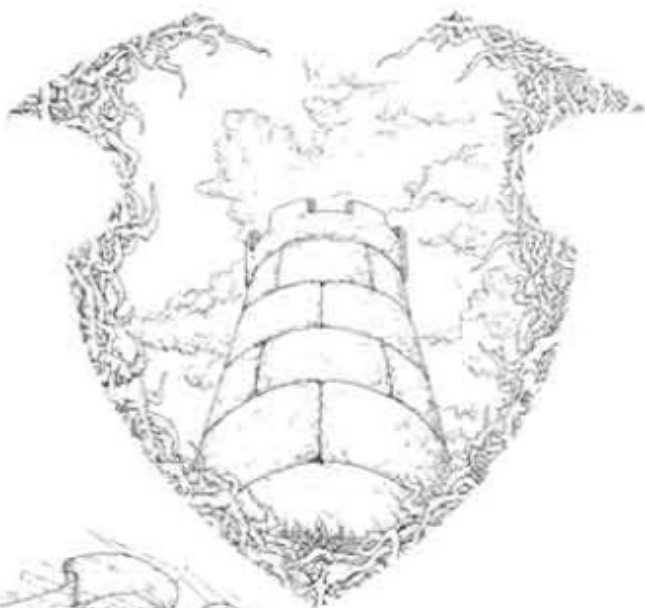

GARY HARROD  
POOLE  
DORSET

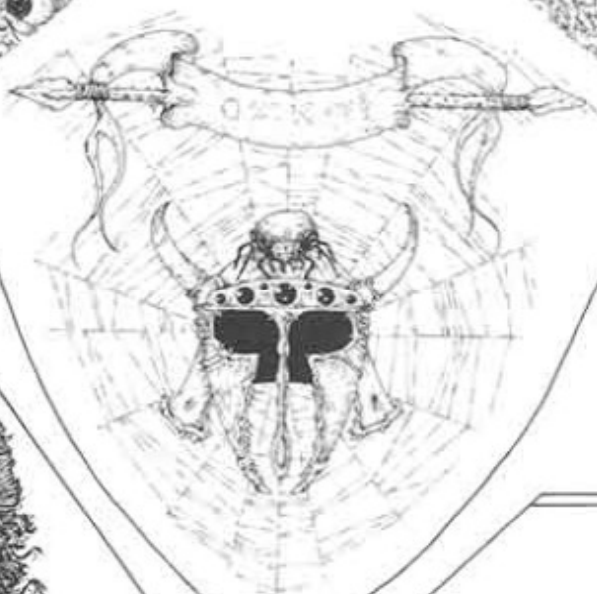

S.A. FRAME  
BATH  
AVON



GARY PARKES  
NOTTINGHAM



Eldritch Epistles features letters, suggestions and comments from gamers and collectors, either about Citadel models or games. Please address your letters to:-

Eldritch Epistles  
Citadel Miniatures  
Chewton St.  
Hilltop  
Eastwood  
Notts  
NG16 3HY

Please enclose an S.A.E if you want a reply or material returning. Please send mail orders and other correspondence separately, otherwise your letter, order or both will almost certainly be delayed, if not lost forever in the depths of the seething lair that is the Mail Order Dept. If writing with Warhammer queries please leave space on your letter for us to write in a reply.

Dear Sirs

I have been purchasing your figures off and on now for almost seven or eight months, and would like to take this opportunity of congratulating you all on the skill of your modellers and all those involved with creating the finished figure. But, especially, I would like to say, 'Thank you!' to your staff involved with dealing with 'Joe' the public. .... Keep up the good work!

G. Davies.  
44 Northdown Rd  
St Peters  
Broadstairs  
Kent

*Believe me you wouldn't be so keen on our staff if you actually met them face to muzzle. They may sound very friendly and helpful, as indeed they are, but, in the interests of public safety, it is still better that these individuals remain firmly in their cages during non-working hours.*



Dear Citadel,

What is this unnatural taint of chaos that has swept the Citadel ranges? Warriors of Chaos and Chaos Beastmen I can handle, but all of a sudden I see Chaos Clerics, Fighters, Wizards and all manner of horrors. As the mighty, fearless, leader of a Dwarf army I'm finding all this chaotic opposition pretty heavy going. So how about some re-inforcements for the Dwarfs?

Yours - Disgruntled Iron-fist

*Worry not my disgruntled friend! We have plans to release a new range of Dwarfs as soon as possible. Chaos Dwarfs.*



*Phil Lewis has this to say about John Blanche's recommended use of the thumb nail as a paint palette.*



*Thank you Phil. Phil has his own painting tip to impart on his fellow brush artists - embodied here in this spectacular photograph of the man himself. The application of fine brush control is clearly demonstrated we feel.*

I've created a Warhammer monster which can be used as a look out or spy in adventures and battles. I call them **Carrion**. They are the descendants of carnivorous birds, captured by Chaos and warped into undead form. I thought that the Carrion would make an interesting miniature for undead collectors.

M	WS	BS	S	T	W	I	A	Ld	Int	Cl	WP
4	3	-	3	3	3	4	3	7	7	7	7



As undead these creatures are immune to psychological effects, but are subject to instability. They fly as **landers** because of the poor, ragged condition of their plumage. As undead they cause **fear** in living creatures.

Ian Harding  
78 Newtown  
Westbury

*A good idea for a Warhammer monster - pretty powerful too! I'll have to try and persuade one of our designers to have a go...now where are the thumb-screws? Anybody out there got any good ideas for other Warhammer monsters or races? If so let's see them.*

Dear Citadel,

Thanks very much for the Citadel Journal! I think that this is a very worthwhile idea, and look forward to seeing the next issue - but - when? when? when?. (**Now! now! now!** - Ed). The card house is really good, and, with a few modifications, has become the centre-piece for one of my dioramas. I have found that the structure can be considerably strengthened using mounting card 'fillets' and 'hinges' inside, notably at the joints and corners. Having said this I was somewhat dismayed to see that you printed the two tower models opposite each other on the same page - making it impossible to make up both models. Perhaps it would have been better to print the buildings on a separate card insert! Lets see more buildings, more photos, more painting articles and more of everything!

Ron Morehead

*Glad you liked the Journal - hope you like this one too! We printed the building on the cover, rather than an insert, because inserts work out expensive. Adding 50p to the cost of the journal wouldn't have been at all acceptable, I'm sure you'd agree. Originally the building had only one tower and we were going to put an advert on the back. But then we thought it would be a better idea to print an alternative tower design. Just goes to show you...you can please some of the people all of the time...etc.*

Many miserable gretchins write to Citadel pleading to be allowed to come and see the famous Citadel Production Dungeon, where all of the drawing, design and other artwork is forged. Sadly, for reasons of public health, national security and our customer's sanity this is not possible. However, in order to satiate this obvious need for horror we present a typical scene from the artistic abyss.

AND NOW.....

## ANOTHER UNIQUE CREATURE FEATURE

### TONY ACKLAND - A WARHAMMER MONSTER



This is the most feared creature that roams the whole Citadel Production Department. It is usually found in its lair, which it builds out of thousands of old car magazines, discarded food, cigarette butts, and decaying brain cells. This pile is so rank and fetid that anyone approaching within 5 metres becomes subject to **revulsion** (must save against WP or faint from disgust). The Ackland beast can be instantly recognised because of its sheer **presence** - and by the large mug of tea which is its principal weapon.

**Physique:-** Considerable.

**World Distribution:-** found only at the end of the Production Dept - surrounded by a spacious and empty waste (The Desolation of Ackland).

**Alignment:-** Varies according to nicotine and tea intake.

**Special Rules:-** Causes **Fear** and **Terror** in everything, including Greater Demons, Gods and people in restaurants. Immune to all psychology, normal weapons, magical weapons and everything else.

**Points Value:-** Infinite.



# SPRING OPEN DAY



Ian Fawcett & Trip Maxton head at work.

Scenes of insane revelry and assorted goings on at the Citadel Open Day. Featured were Warhammer games, a chariot race, bring and battle games, modelling displays, a painting competition, casting and moulding demonstrations, real live combat on the lawns, and **mayhem everywhere!**



Rip Maxton having a Chair spin.



Bryan Ansell & Gary Chalk.



Richard Clardy famous impersonation of Rudy Pardo.



Model making display.



Todd Hlawa and Richard Hask of the Players Guild with their Warhammer display.



Neil Young the Mad Order Fool.



A worried Neil Young being greeted by a host of changes of complexion and other things.



Outragously Lame! Sweet win (jointly by Stephen R. Gilbert & Mark Bennett).



A Citadel caster trying to formulate a four word sentence.



# PSYCHOSTYRENE!

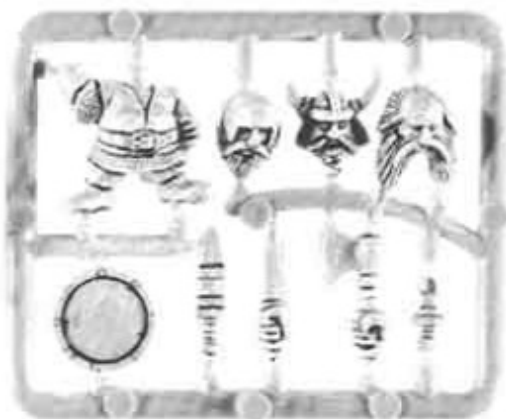

An exciting new limited edition from Citadel. Our first styrene (hard plastic) figure; a 25mm tall Dwarf with a variety of weapons and heads.

Each pack has sufficient parts to make 3 dwarfs and also includes 3 different full colour water-slide shield transfers which adds up to excellent value for money (25p/figure).

Available in Regiments of 30 for £6.00 from **CITADEL MINIATURES**



**ONLY  
75p**

## Assembling Your Card · WAGON MODELS ·

Before assembling the models read through the instructions thoroughly. You will need a pair of scissors, a sharp modelling knife, a safety cutting edge, glue (Uhu, Bostic etc) and some cocktail sticks. The cocktail sticks are to make axles - thick wire would also be O.K. for this.

- 1 Cut out the base and fold the sides inwards.
- 2 Glue the tabs firmly.
- 3 Make holes with a mounting needle, pin or similar and insert the cocktail stick axles. You will have to trim axles to length as appropriate.
- 4 Attach the wheels.
- 5 Cut out the body section and fold the sides upwards.
- 6 Glue the tabs firmly.
- 7 Bend the foot board down and back then glue. Detail should appear on both sides.
- 8 Cut out the floor and glue it inside the body section so that it fits in position. Some trimming may be necessary, so do a dry run first.
- 9 Paint the inside walls of the wagons black or brown. Use Citadel or similar water based paint. Do not use too much paint, or water down the paint, as this will make the model warp.
- 10 The whole model can be glued to a heavy card base for stability. The slave-ogre crew can also be attached if you wish.

### METAL WHEELS

The weakest part of your card wagons will be the wheels, which have to take the weight of the entire model. They will certainly last you for several games, even as they are, but if you want to preserve your wagons it is a good idea to replace the card wheels with metal ones. Metal wheels of the two types illustrated are available direct from Citadel Mail Order for only 10p each - so it is well worth the investment.

### SHIELDS

The new separate styrene shields can be used to decorate the models - greatly enhancing the three-dimensional effect. Shields are available through Citadel Mail order for 1p each. If you only want shields - please include a stamped S.A.E with your order.

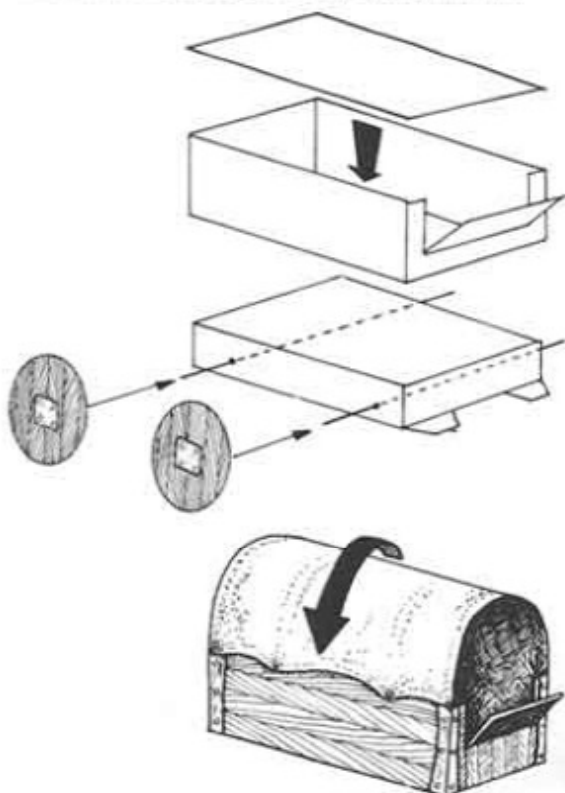

DOLGAN RAIDERS

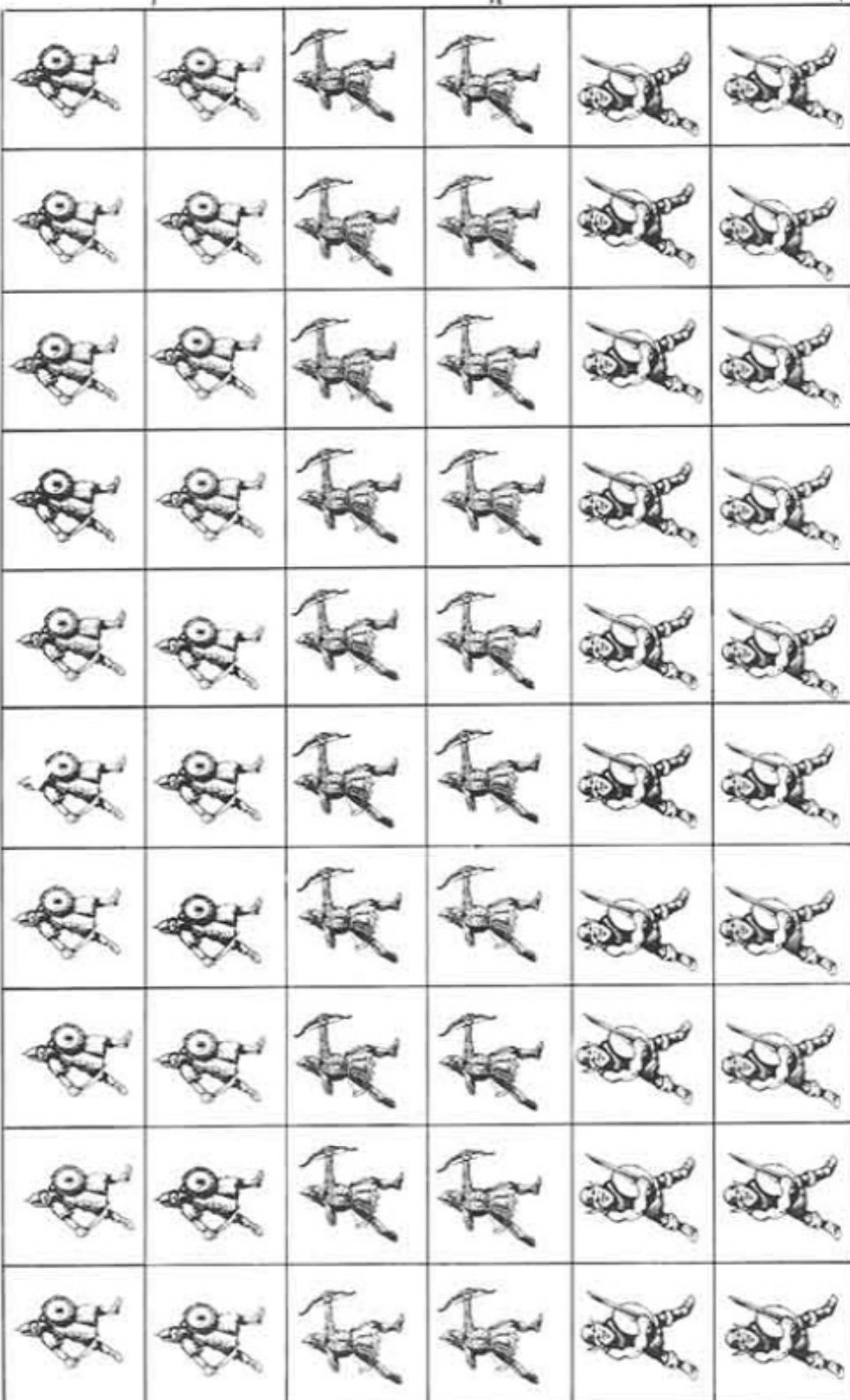
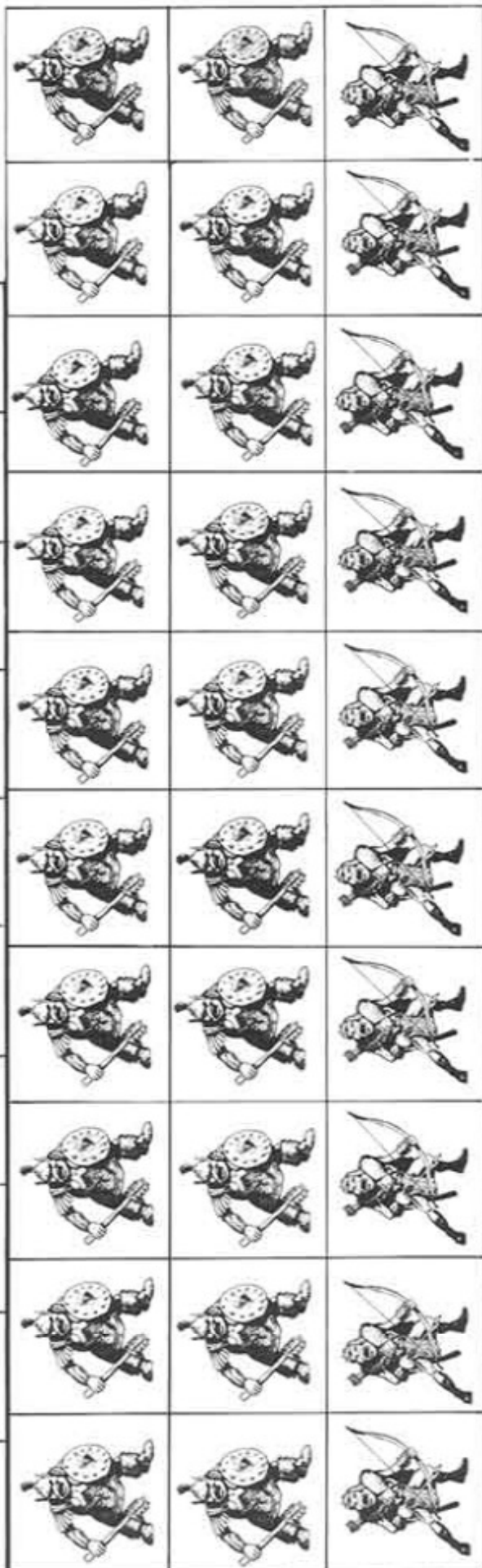
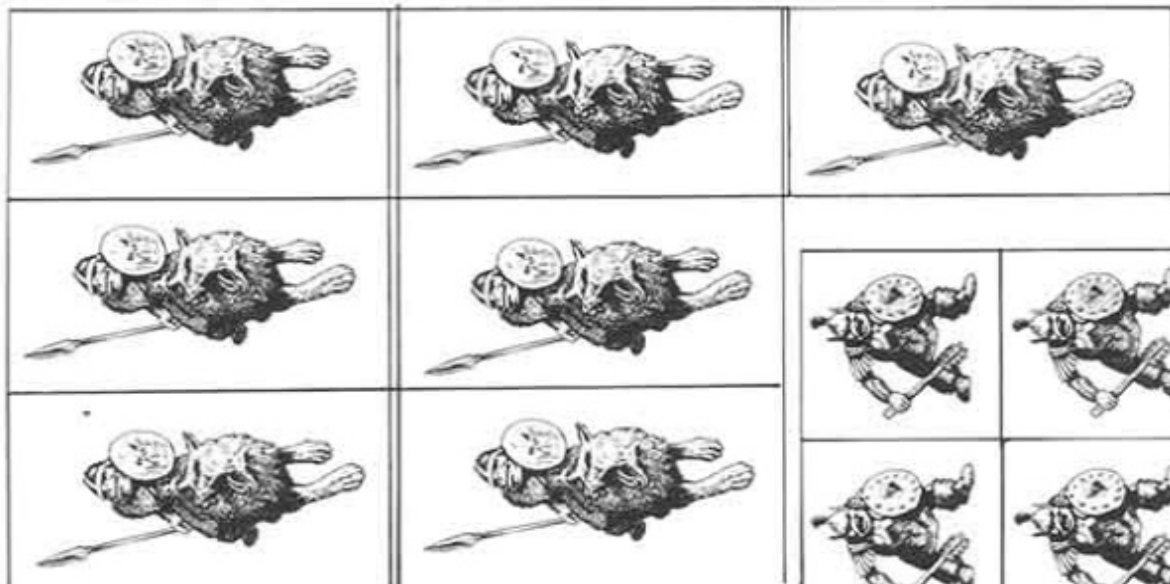



Blackeye



Yuri



Ivan



Gutrot



Maramseth

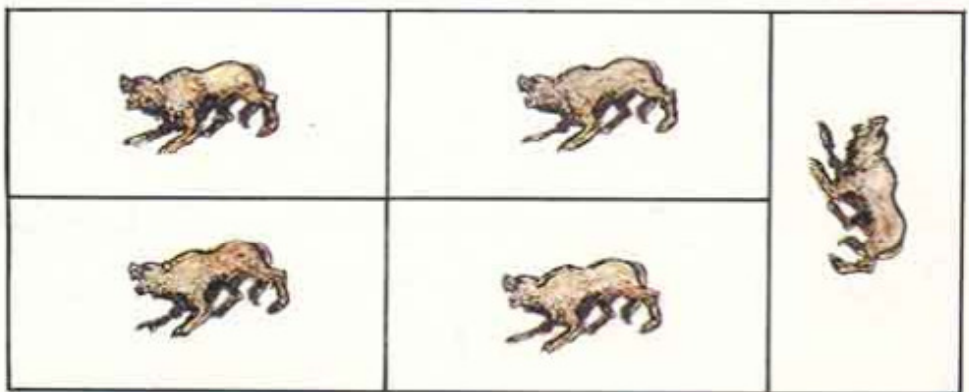

Bagnol

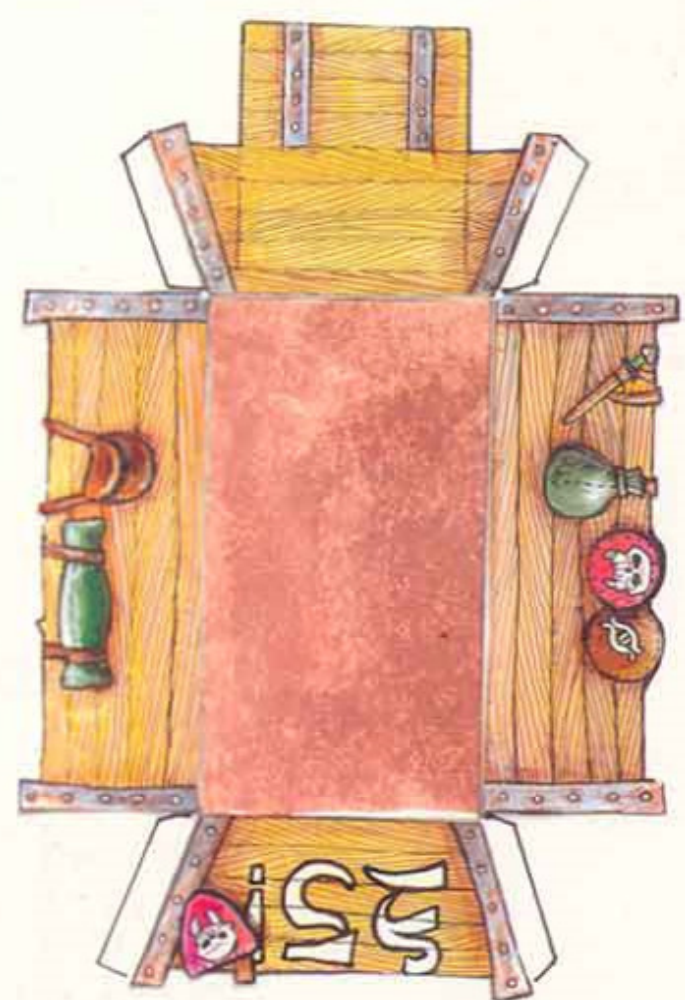
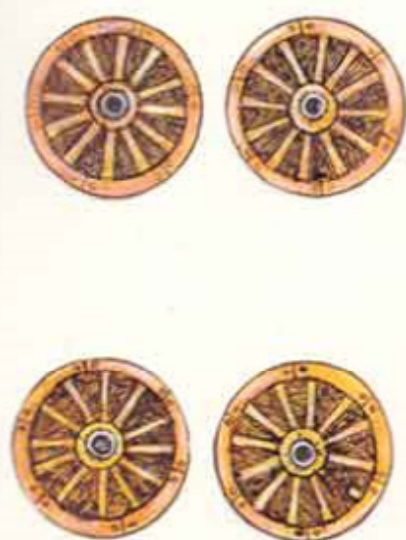
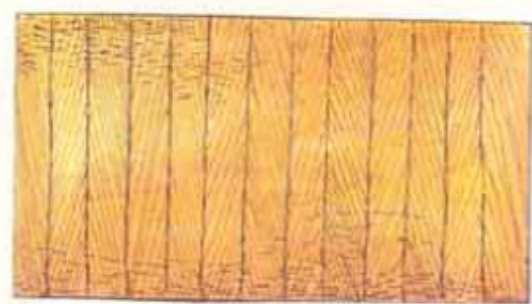

YOU'RE  
NEXT  
PUNK!

# JUDGE DREDD

THE ROLE-PLAYING GAME



"Mega-City One... 400 million people and every one of them a potential criminal. The most violent, evil city on Earth... but, God help me, I love it!" - the words of Judge Dredd. Join Dredd and the Judges on the streets of Mega-City One. ENFORCE THE LAW!

JUDGE DREDD: THE ROLE PLAYING GAME from GAMES WORKSHOP. Miniatures by CITADEL. Available now from all good games shops, or send SAE for full mail order details to: Games Workshop/Citadel Miniatures Mail Order, Chewton St., Hilltop, Eastwood, Notts, UK; or: Games Workshop US, 9110F Red Branch Rd., Columbia, MD 21045, USA.



The Citadel range of fine-cast metal miniatures is available from many retailers the length and breadth of the country. However, if you do not have a retailer near you, then you may be pleased to know that we can offer a fast and effective Mail Order service direct from our factory. Why not write in for details.

We are also able to take orders over the phone by Access or Visa.

Tel MAIL ORDER (0773) 769522

### SUBSCRIBE TO THE CITADEL COMPENDIUM AND JOURNAL!



Here is your chance to ensure that you receive the next four Citadel magazines as soon as they are available! Just send us £6 now, and we'll send you the next four magazines, each worth at least £1.50, as they appear and absolutely post free. The next Compendium is due out sometime around Christmas, and the Journal is published irregularly approximately quarterly. Due to the unbelievably chaotic nature of the Citadel art dept. it is impossible to say for certain exactly when magazines will be published, or indeed whether any given magazine will be a Compendium or Journal! Both the Compendium and the Journal are crammed with illustrations from our extensive ranges of metal miniatures, as well as articles on painting, modelling, Warhammer and numerous special features. Take advantage of this unique offer - subscribe now!

#### SUBSCRIPTION DEAL

THE NEXT FOUR CITADEL MAGAZINES AS THEY APPEAR (APPROX. QUARTERLY), £ 6.00 POST FREE

## REGIMENTS OF RENOWN

RR1	DWARF WARRIORS	£ 4.50	( 8 troopers & 1 leader )
RR2	HEROIC KNIGHTS	£ 4.50	( 8 troopers & 1 leader )
RR3	GOBLIN GUARD	£ 4.50	( 8 troopers & 1 leader )
RR4	DARK ELVES	£ 4.50	( 8 troopers & 1 leader )
RR5	MOUNTAIN ORCS	£ 4.50	( 8 troopers & 1 leader )
RR6	EASTERN FANATICS	£ 4.50	( 8 troopers & 1 leader )
RR7	WOOD ELF ARCHERS	£ 4.50	( 8 troopers & 1 leader )
RR8	OGRES	£ 5.50	( 4 troopers & 1 leader )
RR9	HALF ORCS	£ 4.50	( 8 troopers & 1 leader )
RR10	ELF CAVALRY	£ 4.50	( 3 elves & 1 leader )
RR11	LIZARDMEN	£ 4.50	( 8 troopers & 1 leader )
RR12	GARGOYLES	£ 4.50	( 3 gargoyles & 1 leader )
RR13	ELF INFANTRY	£ 4.50	( 8 troopers & 1 leader )
RR14	ORC ARTILLERY	£ 4.50	( 2 ballista & 4 crew )
RR15	HOBGOBLINS	£ 4.50	( 8 troopers & 1 leader )
RR16	CHAOS MONKS	£ 4.50	( 8 troopers & 1 leader )
RR17	AVENGING KNIGHTS	£ 4.50	( 8 troopers & 1 leader )
RR18	BLACK ORCS	£ 4.50	( 8 troopers & 1 leader )
BN1	GOBLIN WARLORDS CHARIOT	£ 6.50	



## DICE

A full range of Polyhedral Dice suitable for use with all popular Role Playing Games and Wargames, including WARHAMMER.

Dice are available in packs containing the complete range of six different types (1 x Four sided, 1 x Six sided, 1 x Eight sided, 1 x Ten sided, 1 x Twelve sided, and 1 Twenty sided 'Percentile' die) and also in packs of two.



## DICE

FOUR SIDED	.50 Per pack of 2
SIX SIDED	.50 Per pack of 2
EIGHT SIDED	.50 Per pack of 2
TEN SIDED	.50 Per pack of 2
TWELVE SIDED	.50 Per pack of 2
TWENTY SIDED	.50 Per pack of 2
SET OF SIX	£ 1.25



## CITADEL COLOUR PAINTS

1	Skull White	.60
2	Chaos Black	.60
3	Blood Red	.60
4	Bronzed Flesh	.60
5	Woodland Green	.60
6	Enchanted Blue	.60
7	Sunburst Yellow	.60
8	Mithril Silver	.60
9	Shining Gold	.60
10	Rotting Flesh	.60
11	Goblin Green	.60
12	Elf Grey	.60
13	Worm Purple	.60
14	Hobgoblin Orange	.60
15	Orc Brown	.60
16	Spearstaff Brown	.60
17	Swamp Brown	.60
18	Chainmail	.60

## CITADEL COLOUR PAINT SETS

SET ONE (Paints 1-9)	£ 4.95
SET TWO (Paints 10-18)	£ 4.95



## CITADEL

C01	FIGHTERS	.60
C02	WIZARDS	.60
C03	CLERICS	.60
C04	THIEVES	.60
C05	ORIENTAL HEROES	.60
C06	DWARFS	.60
C08	HIGH ELVES	.60
C09	DARK ELVES	.60
C10	HALF-ORCS	.60
C11	HALFLINGS (2)	.95
C11	GNOMES (2)	.95
C12	GOBLINS (4)	1.50
C15	ORCS (3)	1.50
C17	SKELETONS	.60
C18	UNDEAD SAMURAI	.60
C18	ZOMBIES	.60
C19	LIZARDMEN	.65
C20	TROLLS	£ 1.95
C21	LIZARD RIDERS	£ 1.25
C22	CREATURES	£ 1.95
C23	GIANT OGRES	£ 1.95
C24	MONSTERS	.95
C26	MEN-AT-ARMS	£ 1.95
C27	CHAOS CREATURES	£ 1.95
C27	CHAOS BEASTMEN (4)	£ 1.95
C28	GIANTS	£ 3.95
C29	LARGE MONSTERS	£ 1.95
C30	AMAZONS	.60
C31	GIANT MONSTERS	£ 3.00
C33	AIRBORNE WIZARD	£ 1.95
C33	MOUNTED ADVENTURERS	£ 1.95
C34	ELEMENTALS & DEMONS	£ 2.50
C34	LIFE & DEATH ELEMENTALS	£ 2.50
C35	CHAOS WARRIORS	.60
C36	HOBGOBLINS	.60
C37	TOM MEIER'S ELVES	.95
C39	TREASURE CHESTS (2)	.60
C42	BATTLECARS	.60
C43	SPACESHIPS	.75
C44	DREADNOUGHT SPACESHIPS	£ 1.95
C46	TOWNSFOLK & (5) VILLAGERS NPC's	£ 1.95

## chronicle

N11	GIANT BLACK ORCS (3)	£ 1.50
N12	HOBGOBLINS (3)	£ 1.50
N13	KOBOLDS (2)	.95
N14	GIANT OGRES	£ 1.25
N15	WOLF RIDERS	£ 1.25
N16	CAVE GOBLINS	.60

## Advanced Dungeons & Dragons<sup>®</sup> Miniatures

A new concept in tabletop models! Each Player Character Pack comprises three versions of the same character, representing the adventure or a starter character, an experienced adventurer, and, finally, as a fully developed high-level character.

ADD1	MAGIC USER (Player Character Pack)	£ 1.95
ADD2	FIGHTER WITH LONGSWORD (Player Character Pack)	£ 1.95
ADD3	CLERIC WITH MACE (Player Character Pack)	£ 1.95
ADD4	THIEF (Player Character Pack)	£ 1.95
ADD5	ILLUSIONIST (Player Character Pack)	£ 1.95
ADD6	PALADIN (Player Character Pack)	£ 1.95
ADD7	RANGER (Player Character Pack)	£ 1.95
ADD8	ASSASSIN (Player Character Pack)	£ 1.95
ADD9	DRUID (Player Character Pack)	£ 1.95
ADD11	FEMALE MAGIC USER (Player Character Pack)	£ 1.95
ADD52	GOBLINS (4)	£ 1.95
ADD54	HOBGOBLINS (3)	£ 1.95
ADD60	NORKERS (3)	£ 1.95
ADD72	CARRION CRAWLER	£ 1.95
ADD75	GORGON	£ 1.95
ADD77	CRUSTACEAN (6)	£ 1.95
ADD80	BLINK DOGS (4)	£ 1.95
ADD81	OWL BEAR	£ 1.95
ADD84	BEHOLDER	£ 1.95
ADD93	ZOMBIE, SHADOW AND GHOUL	£ 1.95
ADD94	GHAST, WIGHT & LICH	£ 1.95

## DUNGEONS & DRAGONS<sup>®</sup> Miniatures

BDD1	DUNGEON ADVENTURERS STARTER SET	£ 4.95
BDD2	DUNGEON MONSTER STARTER SET	£ 4.95

## WARHAMMER

WARHAMMER -BATTLE- RULES FANTASY GAME	£ 9.95
BLOOD BATH AT ORCS DRIFT	£ 5.95
FORCES OF FANTASY 1 <sup>st</sup> ED	£ 6.95
WARHAMMER SUPPLEMENT	
WARHAMMER POSTERS	£ 2.95

## the Lord of the Rings<sup>®</sup>

### ADVENTURE PACKS

ME11	GANDALF THE WIZARD	£ 1.95
ME12	STRIDER-ARAGORN THE RANGER	£ 1.95
ME13	FRODO THE HOBBIT	£ 1.95
ME14	LEGOLAS - ELF HERO	£ 1.95
ME15	GIMLI - DWARF HERO	£ 1.95
ME21	BOROMIR	£ 1.95
ME22	ELROND	£ 1.95
ME23	ROHIRRIM NOBLE KNIGHT	£ 1.95
ME24	GONDOR CITADEL GUARD	£ 1.95
ME25	RANGERS OF ITHILIEN	£ 1.95
ME31	SILVAN ELVES OF MIRKWOOD	£ 1.95
ME32	NOLDOR: THE DEEP ELVES	£ 1.95
ME34	SHIRE HOBBITS	£ 1.95
ME35	BEORN - WEREBEAR	£ 1.95
ME41	GOBLIN WARG RIDER	£ 1.95
ME42	ORCS OF THE WHITE HAND	£ 1.95
ME43	HALF ORCS OF SARUMAN	£ 1.95
ME44	URUK-HAI - ORC GUARDS	£ 1.95
ME45	DUNLENDINGS (2)	£ 1.95
ME51	ORCS OF THE RED	£ 1.95
ME54	EASTERLING - EVIL RAIDER	£ 1.95
ME61	SAURON-THE DARK LORD	£ 1.95
ME62	SARUMAN THE WHITE	£ 1.95
ME63	LORD OF NAZGUL	£ 1.95
ME64	BLACK RIDER: RINGWRAITH	£ 1.95
ME71	CORSAIRS OF UMBAR: PIRATES	£ 1.95
ME72	DEAD MEN OF DUNHARROW	£ 1.95
ME73	BARROW WIGHTS: VILE UNDEAD	£ 1.95
ME74	SNAGGA - GOBLINS	£ 1.95
ME75	KNIGHT OF DOL AMROTH	£ 1.95
ME83	TOM BOMBADIL	£ 1.95

## RUNESCAPE

MONSTERS	£ 1.25
CHAOS BROO	.60
ADVENTURERS	.60

# FIGHTING FANTASY™

60mm Plastic Figures

FF1	MYSTIC WIZARD I	.65
FF2	MYSTIC WIZARD II	.65
FF3	MYSTIC WIZARD III	.65
FF4	MIGHTY THEWED BARBARIAN I	.65
FF5	MIGHTY THEWED BARBARIAN II	.65
FF6	MIGHTY THEWED BARBARIAN III	.65
FF7	HEROIC KNIGHT I	.65
FF8	HEROIC KNIGHT II	.65
FF9	HEROIC KNIGHT III	.65
FF10	WARRIOR OF CHAOS I	.65
FF11	WARRIOR OF CHAOS II	.65
FF12	WARRIOR OF CHAOS III	.65
FF13	FEARLESS DWARF I	.65
FF14	FEARLESS DWARF II	.65
FF15	FEARLESS DWARF III	.65
FF16	DEADLY SKELETON I	.65
FF17	DEADLY SKELETON II	.65
FF18	DEADLY SKELETON III	.65
FF19	EVIL GOBLIN I	.65
FF20	EVIL GOBLIN II	.65
FF21	EVIL GOBLIN III	.65
FF22	VILE ORC I	.65
FF23	VILE ORC II	.65
FF24	VILE ORC III	.65
FF25	FEROCIOUS OGRE I	£ 1.25
FF26	FEROCIOUS OGRE II	£ 1.25
FF27	FEROCIOUS OGRE III	£ 1.25
FF28	PAINT & PAINTING GUIDE	£ 1.25
FF29	RULES AND DICE	£ 1.25

WEAPONS SPRUE	.10
INDIVIDUAL HEADS	.05

# PSYCHOSTYRENE!



An exciting new limited edition from Citadel. Our first styrene (hard plastic) figures: a 25mm tall Dwarf with a variety of weapons and heads.

Each pack has sufficient parts to make 3 dwarfs and also includes 3 different full colour water-slide shield transfers which add up to excellent value for money (25p/figure).

P1 DWARF (3) .75



ONLY  
75p

SPECIAL OFFER REGIMENT OF 30 DWARFS £ 6.00

## THE DOLGAN RAIDERS DEAL

DOLGAN RAIDERS		PRICE
DR1	Personalities. Ivan, The Storyteller, Terek & his Wardogs	£ 4.75
DR2	Yuri's Bowman. Yuri & 20 Archers	£ 11.00
DR3	Stephan's Swordsmen. Stephan & 20 Fighters	£ 11.00
DR4	The Complete Dolgan Army. ( 50 Miniatures )	£ 24.00
HOBGOBLIN CARAVAN		
DR5	Bagnol and the Hobgoblins. Bagnol, 20 fighters & 10 Archers	£ 14.50
DR6	Gutrot and the Wolfriders. Gutrot, his Wolf & 9 wolfriders	£ 11.50
DR7	Blackeye & the Slave Ogres. Blackeye & 6 Giant Ogres	£ 12.00
DR8	The Camp Followers. 20 Goblins & 10 Lesser Goblins.	£ 9.50
DR9	The Complete Goblin Caravan. ( 78 Miniatures )	£ 42.00

DR10 THE COMPLETE ARMIES TOGETHER FOR £ 60.00

Wheels for the Caravans.

£ 0.10p Each

## Arcaic Monstrosities

Advanced Modellers Only

TA1	GOLGOTH - MIGHTY LORD OF BALROGS	£ 9.95
TA2	JUGGERNAUT - Huge steam powered war machine with Dwarf crew.	£25.95
TA3	ORC WAR WYVERN	£ 6.95
TA4	MONSTROUS ORC WAR MACHINE	£ 6.95
TA5	WAR EAGLE	£ 7.50
TA6	EMPEROR DRAGON	£29.95
TA7	GIANT CHAOS BATTERING RAM	£29.95

### DRAGONS

DG1	ORIENTAL DRAGON	£ 4.95
DG2	RED DRAGON	£ 6.50
DG3	BLUE DRAGON	£ 4.94
DG4	BLACK DRAGON	£ 6.50
DG5	FIRE DRAGON	£ 6.50
NB1	SPINED DRAGON	£15.00

### MONSTER BOXES

CM1	CHAOS CHIMERA	£ 3.95
-----	---------------	--------

## BATTLETRUCK

BT1	BATTLETRUCK SET	£ 2.50
-----	-----------------	--------



GH1	GOLDEN HEROES	£ 5.50
GH2	VILLAINS	£ 5.50



LW1	GIAC ATTACK	£ 5.50
Lone Wolf	Blisters	.60

### Board Starter Sets

BC1	ADVENTURERS	£ 4.95
BC2	MONSTERS	£ 4.95

### DIORAMA SETS

DS1	DWARF CANNON	£ 4.50
DS2	DUNGEON EQUIPMENT	£ 4.50
DS3	GRAVEYARD	£ 4.50



### BASES

20mm (SQUARE)	.02 p
25mm (SQUARE)	.02 p
HEXAGONAL	.02 p
HORSE/MONSTER (OBLONG)	
( 25mm x 50mm )	.03 p
FLYING BASES	.05 p
40mm (SQUARE)	.06 p
PLASTIC SHIELD	.01 p

### THE CITADEL JOURNAL

No 1 SPRING 85 £ 1.50