

No.27

US \$3.25

# CHALLENGE

GDW's Magazine of Adventure Gaming

For Traveller: 2300—  
The North American Research League,  
by Timothy Brown

Chosen at Random  
by Gary Thomas



Incorporating the Journal of the Traveller's Aid Society

## DISCOVER Grand Survey!

After years of waiting, Traveller fans can finally read GRAND SURVEY — and the wait was worth it. This full-size, 48-page book is packed with excitement for both players and referees.

**DESIGN A WORLD:** starting with the basic Traveller UPP for the world, GRAND SURVEY leads you step-by-step to detailed physical characteristics and an accurate map of the world.

**SURVEY A WORLD: GRAND SURVEY** tells you everything you need to know, including details of survey procedures, sensors, the DONOSEV Class Scout Survey Vessel, and landing party equipment. Ideal for players!

**ADVENTURE ON A WORLD:** a special section tells referees how to use the new wealth of world information to make adventures more exciting, more realistic, and more fun.

8.5" x 11", Full color cover, \$7

Approved for Use With **TRAVELLER**

# Grand Survey

Exploring and Detailing Worlds

Surveying a World

## SURVEYING A WORLD

YACC SUITS  
It is light and comfortable, designed to wear under mild to hot atmospheric conditions under clothes, but is of no benefit in 3 atm (thin atmospheric) without the search against temperatures +50°C to +25.5 atm.

Suits are usually hard molded. This is more generally, but when they are so. YACC suit skill or battle dress skill is an environment suit; if the character has attempted to automatically considered.

SUIT (LT. DUTY YACC SUIT)	Weight	Price	Encumbrance to Dexterity
—	—	12,500	—

Age (20 min): 0.75 kg, Cr 250  
Cr 2,500

ARMORMENT YACC SUITS

Weight	Price	Encumbrance to Dexterity
35 kg	Cr 12,000	-3
40 kg	Cr 16,000	-3
45 kg	Cr 18,000	-3
10 kg	Cr 20,000	-3
25 kg	Cr 150,000	-2

TL 14 TL 15

Digest Group Publications

Page 22

## The TRAVELLERS' DIGEST MAGAZINE



THE TRAVELLER'S DIGEST MEANS ADVENTURE

Do you want more from Traveller? Travellers' Digest has what you want. Join our growing number of readers and soon you'll be making comments like these:

"congratulations on a product that has beaten out everything else on the market in quality, playability, and content...I truly enjoy every page of your outstanding magazine" - VF

"a superior magazine" - SP

"a friend showed me your magazine...I must have my own copy!" - RP

"excellent...I am most impressed" - PDH

"a great magazine" - DLH

"I have read only great things about your new publication and want to subscribe" - JM

"high quality" - RB

"I am delighted...it was my rare good fortune to encounter your magazine at a local games store...accept my compliments" - WFS

"an excellent publication...I am very pleased...continue the good work" - CJW

Adventure #4: "The Gold of Zurrian" (limited supply)

Adventure #5: "The Humaniti Experiment"

Adventure #6: "The Most Valuable Prey" (available September 1)

Subscription (4 issues)... \$14 Overseas (air mail, US funds only)...\$22

\$3.95 each

## Available at your TRAVELLER dealer today!

Or send check or money order to: Digest Group Publications, 8979 Mandan Ct., Boise, ID 83709. Please include \$1 per order for postage and handling; OVERSEAS orders please include \$2.50 for postage and handling.

MasterCard and VISA accepted — Phone (208) 362-3094.

## Now Available for MACINTOSH! Computer Programs for TRAVELLER®

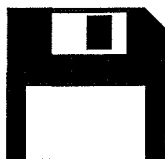

Disk 1: WORDGEN/BESTIARY automatically produces random words (using the procedures in GDW's Alien Modules) for ASLAN, VARGR, DROYNE, ZHODANI, VILANI, and K'KREE. BESTIARY creates animal encounter tables; you decide the environment and BESTIARY does the rest. Specify whether you want MSBASIC source code or a stand-alone version.

Disk 2: FORMS and ART contains MacPaint and MacDraw documents, including world, subsector, sector map grids, and a collection of the more popular illustrations from the TRAVELLERS' DIGEST.

\$18.50 each plus 1.50 postage and handling. Only available direct from DIGEST GROUP PUBLICATIONS.

# CHALLENGE

GDW's Magazine of Adventure Gaming

Managing Editor  
Loren K. Wiseman

Associate Editor  
Timothy B. Brown

Spiritual Advisor  
Marc W. Miller

Art Director  
Barbie Pratt

Publisher  
Game Designers' Workshop

Artists in this issue: *Steve Venters*: cover, pps 23, 24-25, 39; *D.J. Barr*: pps 17, 18, 19, 20, 21; *Liz Danforth*: pp 35; *Tim Bradstreet*: pps 3, 6, 9, 26, 27, 29, 31, 32; *Dana Reischauer*: pp 10; *S. S. Crompton*: pp 42; *Rob Caswell*: pp 15.

*Challenge*, GDW's magazine of Adventure Gaming is published quarterly, and includes the *Journal of the Travellers' Aid Society* as an internal section.

*Journal of the Travellers' Aid Society* is Game Designers' Workshop's registered trademark for its science fiction gaming magazine devoted to *Traveller*.

*Traveller* is Game Designers' Workshop's registered trademark for its role-playing game of science fiction adventure set in the far future.

*Twilight: 2000* is Game Designers' Workshop's trademark for its role-playing game of survival in a devastated world.

*Traveller: 2300* is Game Designers' Workshop's trademark for its science fiction role-playing game set in the 24th century.

*Challenge* is copyright © 1986 by Game Designers' Workshop. Printed in the U.S.A. All rights reserved. ISSN: 0193-3124. All editorial and general mail should be sent to *Challenge*, P.O. Box 1646, Bloomington, IL 61702-1646.

The individual issue price is \$3.25. One year subscriptions are \$13 in the United States and Canada. Foreign subscriptions (outside the U.S. and Canada, but not to APO or FPO addresses) are \$25 per year, which includes airmail postage. Please make all payments in U.S. funds drawn on a U.S. bank.

*Submissions*: We welcome articles and illustrations for the *Challenge*. Please inquire before submitting manuscripts, enclosing a stamped, self-addressed envelope; we will send manuscript guideline and format sheets. Foreign inquiries (except APO/FPO) please include an International Reply Coupon.

## GDW LIBRARY

### Adventure Scenario

Chosen at Random, by *Gary L. Thomas*.....17

### Traveller Articles

Fighter Profile: The Rampart IV and V, by *Robert Liebman*.....23

Church of the Chosen Ones, by *Gary L. Thomas*.....26

Grandfather's Worlds, by *Marc W. Miller*.....35

Journalism and the Stars, by *Anders Blixt*.....44

### Twilight: 2000 Articles

The Mexican Army: 1998-2000, by *Frank A. Chadwick*.....3

The Inland Waterway: Supplementary Material for *Twilight: 2000*,  
by *William H. Keith, Jr.*.....6

Target: 2000, The Hit List for WWII, by *Loren K. Wiseman*.....9

*Twilight: 2000* Consolidated Price List, by *Loren K. Wiseman*.....11

### Traveller: 2300 Articles

*Traveller: 2300* Designer's Notes, by *Marc W. Miller*.....38

The North American Research League, by *Timothy B. Brown*.....39

### Features

From The Management.....2

Just Detected.....2

Ship's Locker: Vargr Grav Platforms, by *J. Andrew Keith*.....29

Bestiary: Oegongong, by *Joe D. Fugate, Sr.*.....31

Small Cargos—Three for the Road, by *J. Andrew Keith*.....33

Casual Encounter: Cain, by *Anders Blixt*.....42

*Traveller* News Service.....45

*Challenge* Classifieds.....48

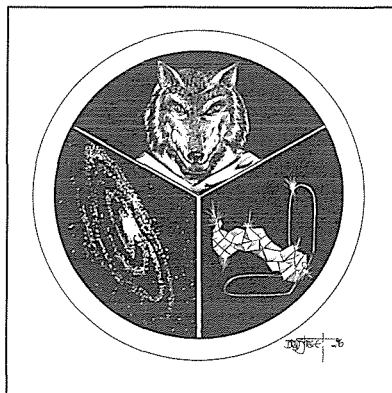

page 26

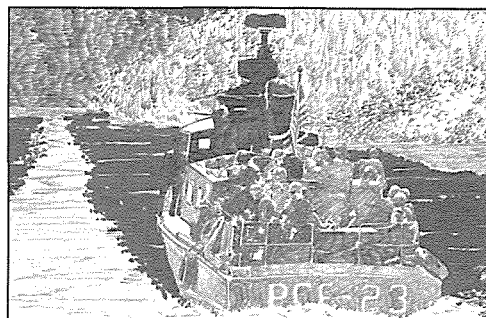

page 6

## MEMO

By:  
Loren K.  
Wiseman

## From the Management

Reader feedback on the new format has begun to taper off (everyone who wants to has gotten their two cents in), and we've had a chance to look it over. By and large, everyone (well, almost everyone) seems satisfied with the larger size. No one commented on our new typeface, or the new page layouts, but we didn't really expect anyone to notice (or care very much).

As for the combination of **Twilight: 2000** and **Traveller**, about half of those writing in are players of one game who are interested in seeing about the other. A fair number (about a quarter) are interested in both games. The rest of those writing in were dissatisfied with one game or the other being covered at the expense of their favorite. A minority of this last group wants to see two separate magazines (which is just not feasible for us now or in the near future).

We have a lot of great articles in this issue, but the one which will hold the most interest for our readers is the announcement of our new game, **Traveller: 2300** (which I'll leave up to Marc to explain).  
—Loren K. Wiseman

Issue 26 feedbacked as follows:

Amber Zone: Tournament.....	3.65
Amber Zone: The Tuktaar Connection.....	3.60
<b>Twilight: 2000</b> Air Module.....	3.48
Ref's Notes: Flow Charts.....	3.20
Cargo: A <i>Merchant Prince</i> Variant.....	4.28
<i>Striker</i> Weapons Systems Revisited.....	4.28
Volcanoes.....	3.85
Military Academy.....	3.70
From the Management.....	3.08
Just Detected.....	3.05
Equipment List.....	3.53
Contact: The Pr't.....	3.63
<b>Traveller</b> News Service.....	3.20
Electronically Exploring the <b>Traveller</b> Universe.....	3.70
Casual Encounter: Boomer Brankovich.....	3.55
<i>Challenge</i> Classifieds.....	3.43
Issue 26 as a Whole.....	3.78

# JUST DETECTED

## CONVENTIONS

### Pandemonium IV

January 17, 1987, Ryerson Polytechnical Institute, Toronto, Ontario, Canada. Role-playing tournaments (including **Traveller**, **Twilight: 2000**), boardgames (including *Blue Max*), miniature contests, auctions, dealers, and more. For more information, contact: The General Staff, PO Box 425, Station A, Downsview, Ontario, Canada, M3M 3A8.

### Orcon 1987

February 13-16, 1987, Los Angeles Airport Hyatt Hotel. Role-playing, wargames, miniatures, computer and family board-game tournaments, flea markets, auction, seminars, demonstrations, and exhibitor area. For more information, contact Orcon 1987, C/O DTI, PO Box 8399, Long Beach, CA 90808, or call (213) 420-3675.

### DunDraCon XI

February 13-16, 1987, Oakland Airport Hyatt. Open gaming, con-sponsored games, dealers' room, seminars, SCA demonstrations, a flea market, and a figure painting contest. For information write: DunDraCon XI, 386 Alcatraz Ave, Oakland, CA 94618.

### Montreal Folie-Con '87

February 27-March 1, 1987, Downtown Ramada Inn, Montreal. Role-playing, wargames, miniatures, 24 hour nonstop video movies, *Blue Max*, **Twilight: 2000**, **Traveller** events (in French and English). For information write: Folie-Con '87, 4651 Berri, Montreal, PQ, Canada, H2J 2R6.

## MAGAZINES

### Travellers' Digest

Issue number 6 is in hand, featuring "The Most Valuable Prey," and "Tech Briefs: Grav Belts." Single issues are \$3.95, one year (four issues) subscription is \$14.00. Digest Group Publications, 8979 Mandan Ct., Boise, ID 83709.

GDW products (including **Traveller**) are available through distributors as follows:

**West Germany:** GDW products are imported and distributed by Fantastic Shop, Kon Kordiastr. 61, Postfach: 3026, 4000 Dusseldorf 1, West Germany. Some titles are translated into German.

**Japan:** GDW products are printed and distributed by Hobby Japan Co., LTD, 26-5, 5-Chome, Sendagaya, Shibuya-Ku, Tokyo, Japan. Titles published are translated into Japanese.

**United Kingdom:** GDW products are imported and distributed by Games Workshop, LTD., Chewton St., Hilltop, Eastwood, Nottingham, NG16 3HY, UK; by Games, 89 Victoria St, Liverpool, L1 6DG, UK; and by Virgin Games Centre, 41-43 Standard Rd, London, NW10 6HF, UK.

**Italy:** GDW products are imported and distributed by Pacific Enterprise Italia, Via R. Di Lauria 15, 20149 Milano, Italy.

**Sweden:** GDW products are imported and distributed by Hobbyhuset, Box 2003, S-750 02, Uppsala, Sweden and by Target Games, Frihamnen S-100 56, Stockholm, Sweden.

**New Zealand:** GDW products are imported and distributed by Blackwood Gayle, PO Box 28358, Auckland, New Zealand.

**Australia:** GDW products are imported and distributed by Jedko Games, PO Box 164, Moorabbin, Vic, Australia 3198.

# The Mexican Army: 1998–2000

Before the war, the Mexican Army consisted of 100,000 active troops and 60,000 reservists. Active forces comprised a Presidential Guard Brigade, two mechanized brigades, three armored cavalry regiments and 36 regional brigades. The Presidential Guard Brigade consisted of three infantry regiments. Each mechanized brigade consisted of two mechanized infantry regiments, one armored recon regiment, and one self-propelled artillery *grupo* (battalion). The armored cavalry regiments were battalion-sized groups of armored cars and infantry carried in wheeled armored personnel carriers. The 36 regional brigades varied in strength, but their average strength was one motorized cavalry regiment, two infantry regiments, and one battery of artillery. The mechanized brigades and armored cavalry regiments were numbered. (All regiments were organized as a single battalion.) The artillery for the regional brigades were provided by detached batteries of three numbered artillery regiments. Regional brigades themselves were designated by the city or town that constituted their peacetime station, and their component regiments also carried a variation of that as a designation. (For example, the Monclova Brigade con-

sisted of the Monclova Cavalry, the 1st and 2nd Monclova Infantry, and the 6th Battery of the 2nd Artillery.)

Reservists were intended to bring prewar units up to full strength and to provide replacements. In actuality, they were used to form additional infantry regiments. These regiments were referred to as *Activo* regiments and generally carried the designation of the city or state from which they were recruited. In many cases, these were recruited from the same cities as the peacetime stations of regional brigades, in which case they assumed the next available number for infantry regiments from that region. For example, *Brigada Mexicali* had two infantry regiments before the war. An additional regiment of reservists was raised from Mexicali and designated the *3o Regimiento Infanteria Activo Mexicali*. One additional light artillery battalion of three batteries was formed from reservists as well.

## EQUIPMENT

**Artillery:** Each mechanized brigade had 6 M109 SP 155mm howitzers and 12 M108 105mm SP howitzers. All artillery batteries in the regional brigades were equipped with 105mm howitzers. Mobilized reservists manned three bat-

teries of antique 75mm pack howitzers that had seen duty with the 4th Army in southeastern Texas.

**Armored Vehicles:** Armored cavalry regiments and armored recon battalions included a squadron of seventeen ERC-90 armored cars and two squadrons of infantry in VAB armored personnel carriers (both of French manufacture). Some motorized cavalry regiments included a mixed squadron of VABs and ERC90s (trucks and jeeps carried the other squadrons of the regiment). Mechanized infantry regiments included forty VAB APCs.

**Support Weapons:** Each regiment included eighteen 60mm mortars (6 per company) and six jeep-mounted TOW systems. However, many regiments of regional brigades had not received TOW by the outbreak of hostilities. A variety of obsolete light antitank systems were also in use, the most common being the 2.75" M9 Bazooka of World War II vintage. A small quantity of modern light AAA guns were also received prior to the war, and 8 such guns were attached to each of the three regular brigades. In the Presidential Guard these were twin 30mm guns, while in the 1a and 2a brigades these were twin 20mm guns. In all cases the guns were towed.

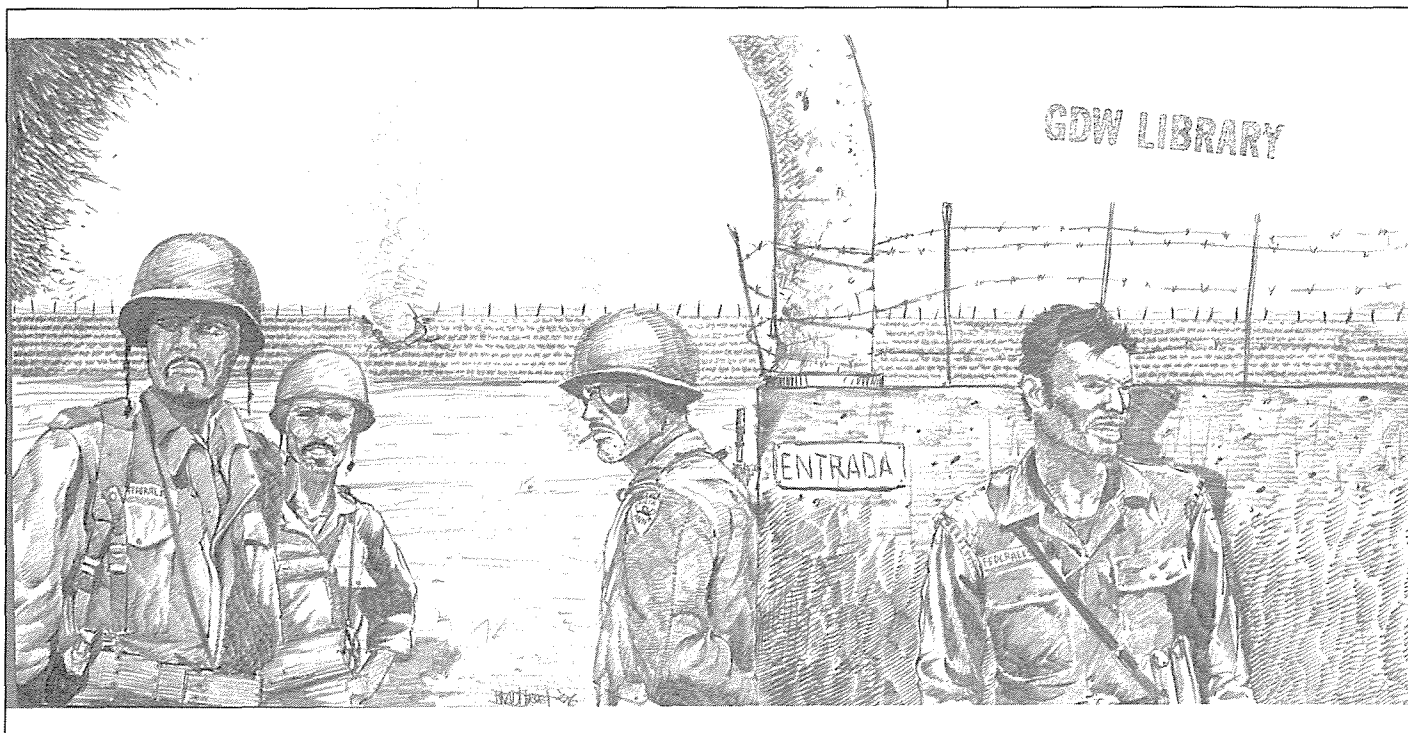

## THE INVASION

Invasion forces constituted three major field commands designated the 2o (2nd), 3o (3rd), and 4o (4th) Armies. The 1o (1st) Army controlled forces in the interior.

The 2nd Army controlled all forces west of the Sierra Madre Occidental and moved into southern California and Arizona. The right flank of the army consisted of the Nogales Brigade, which drove north up Interstate 19. The brigade was initially backed up by the Hermosillo Brigade, but this was soon shifted west along (Mexico) Highway 2 to reinforce the main body of the army.

The 2nd Army's main effort was directed at Southern California. The army was spearheaded by the 2nd Armored Cavalry Regiment and the 1a Brigade (Mechanized). Immediate support was provided by the Ensenada and Mexicali Brigades, soon joined by the Hermosillo and La Paz Brigades. Months later the army was also reinforced with elements of the Culiacan and Tepic Brigades, four regiments of reservist infantry, and somewhat more than twenty independent companies of *Voluntarios* (irregulars). In 1999, the Colima Brigade also joined the 2nd Army.

The 3rd Army initially consisted of the 3rd Armored Cavalry Regiment and the Ciudad Juarez and Chihuahua Brigades. The armor backed up the Ciudad Juarez Brigade in its drive through El Paso, but this thrust was soon stalled by troops at Fort Bliss. The right flank column of the army, consisting of the Chihuahua Brigade, crossed the Rio Grande at Presidio and drove north up Highway 67 toward Odessa. Largely unopposed, the brigade made good time and was soon entirely motorized using requisitioned civilian motor vehicles. Faced with stubborn resistance at Fort Bliss, the 3rd Army executed a wide double envelopment. The Chihuahua Brigade remained west of the Pecos and drove north to Artesia, New Mexico, then turned west to close in on Las Cruces, New Mexico. At the same time, 3rd Army's main body detached the 3rd Armored Cavalry and Juarez Motorized Cavalry to move north along the west bank of the Rio Grande toward Las Cruces. When advanced elements of these two forces met, defending U.S. troops at Fort Bliss began retreating north. Mobile elements of the Mexican 3rd Army were severely mauled by the breakout of the Fort Bliss School Brigade, but the infantry of the Ciudad Juarez Brigade had by now been reinforced by the motorized cavalry regiments of the Durango and Torreon Brigades (with the infantry battalions of those brigades following on foot). The 3rd Army was therefore able to feed additional mobile units forward and avoid a crisis.

Further east, the 4th Army invaded southern Texas on a broad front. The 3rd Armored Cavalry Regiment, backed up by the Monterrey Brigade, crossed the Rio Grande at Laredo and drove north along Interstate 35 toward San Antonio. Its left flank was protected by the Monclova Brigade, which crossed at Eagle Pass and operated toward San Antonio along highways 57 and 90. The right flank drive of the army (the so-called "Coastal Column") consisted of the 2a Brigade (Mechanized), the Matamoros Brigade, and the Ciudad Victoria Brigade. The column crossed the Rio Grande at Brownsville and drove up the coast toward Corpus Christi. Communications were maintained between the two main columns by the Saltillo Brigade, which crossed the Rio Grande at Roma and Pharr.

## REINFORCEMENTS IN 1999

To meet the US 5th Army drive into Texas, the following units were shifted north and assigned to the 4o Army:

*Brigada Tampico, Brigada San Luis Potosi, Brigada Queretaro, Brigada Veracruz, Brigada Zacatecas.*

The following brigades remained in the interior in the 1st Army and in two independent commands (the Yucatan Army and the Chiapas Army):

### First Army

*Presidential Guard Brigade, Brigada Guadalajara, Brigada Aguascaliente, Brigada Ciudad de Mexico, Brigada Cuernavaca, Brigada Chilpancingo de los Bravos, Brigada Tulancingo, Brigada Puebla, Brigada Morelia, Brigada Oaxaca.*

### Yucatan Army

*Brigada Merida, Brigada Ciudad Chetumal*

### Chiapas Army

*Brigada Villahermosa, Brigada Tuxtla Gutierrez, Brigada Tapachula.*

## CURRENT OB

Due to the civil war in Mexico, the various Mexican forces have splintered. The following represents their organization as of July, 2000.

## NATIONALISTS (ENM)

### 1o Ejercito (Central Mexico)

*Brigada Guardia Presidencial: 1,200 men*  
*Brigada Cuernavaca: 1,300 men*  
*Brigada Chilpancingo de los Bravos: 1,500 men, 2 AFV*  
*Brigada Oaxaca: 1,400 men, 4 AFVs*  
*Brigada Guadalajara: 1200 men*  
*Regimiento Infanteria Activo Jalisco: 200 men*  
*Regimiento Caballeria Activo Salamanca: 100 men*  
*Regimiento Infanteria Activo Zamora: 100 men*

### 3o Ejercito (Southern Chihuahua)

*3o Regimiento Caballeria: 300 men, 2 AFVs*  
*Brigada Durango: 400 men, 3 AFVs*

### 4o Ejercito (Texas)

*2a Brigada: 500 men, 4 AFVs (Austin)*  
*Brigada Saltillo: 200 men (Beeville)*  
*Brigada Tampico: 600 men (McAllen—Harlingen)*  
*Agrupacion Jimenez: 300 men, 3 AFVs (Near Laredo); (formed from detachments of the Saltillo and Tampico brigades)*  
*Brigada Queretaro: 800 men (Waco)*

### Ejercito Yucatan (Yucatan)

*Brigada Ciudad Chetumal: 500 men, 2 AFVs*  
*Agrupacion Garcia: 200 men (local conscripts)*

### Ejercito Sonora (Sonora and Southern Arizona)

*Brigada Colima: 1100 men, 4 AFVs*  
*Brigada Mexicali: 600 men, 4 AFVs*  
*Brigada Culiacan: 800 men*

*Regimiento Infanteria Activo Los Mochis*: 200 men  
*Regimiento Infanteria Activo Guaymas*: 100 men

#### **Ejercito Chiapas (Chiapas)**

*Brigada Villahermosa*: 600 men, 1 AFVs  
*Agrupacion Montoya*: 100 men (local conscripts)  
*Agrupacion del Sur*: 200 men (local conscripts)

#### **FRMP**

##### **Southern Texas**

*Bandera Simon Bolivar*: 200 (formed from elements of various Nationalist defectors and local guerrillas; no fixed location)  
*Bandera Benito Juarez*: 50 (formed from elements of various Nationalist defectors and local guerrillas; Gonzales area)

##### **Central Mexico**

*Bandera Bernardo O'Higgins*: 500 (formed from elements of various Nationalist defectors and local guerrillas)

#### **CONSTITUTIONALISTS (EMC)**

##### **Ejercito del Norte (Southern Texas)**

*3o Regimiento Caballeria*: 300 men, 3 AFVs (Carrizo Springs)  
*Brigada Monclova*: 300 men (Cerralvo)  
*Brigada San Luis Potosi*: 600 men (Rio Grande City—Falfurrias—Raymondville)  
*Brigada Veracruz*: 800 (Crystal City—Pearasall—Uvalde)

##### **Ejercito de Mexico Central (Central Mexico)**

*Brigada Ciudad de Mexico*: 1,200 men  
*Brigada Tulancingo*: 1,400 men  
*Regimiento Infanteria Activo Jalisco*: 300 men  
*Agrupacion de Caballeria*: 500 men, 4 AFVs

##### **Ejercito de California (Southern California and Baja California)**

*1a Brigada*: 1,100 men, 6 AFVs  
*2o Regimiento Caballeria*: 500 men, 2 AFV  
*Brigada La Paz*: 600 men, 3 AFVs  
*Brigada Nogales*: 600 men, 1 AFV  
*Brigada Hermosillo*: 700 men, 4 AFVs  
*Regimiento Infanteria Activo Tijuana*: 200 men

##### **Ejercito de los Pecos (South New Mexico, West Texas, North Chihuahua)**

*Brigada Chihuahua*: 800 men, 2 AFVs  
*2o Regimiento Infanteria Torreon*: 300 men  
*Regimiento Infanteria Activo Hidalgo del Parral*: 100 men

##### **Ejercito del Sud (Yucatan)**

*Brigada Tapachula*: 600 men  
*Regimiento Infanteria Activo Campeche*: 200 men

#### **ALLIANCE (ANAMEL)**

##### **Southern Texas**

*Tercio Vanguardia*: 400 men, 2 AFVs (near Laredo; formerly *Brigada Monterrey* of the Nationalist Army)  
*Tercio Libertad*: 50 (Corpus Christi) (formed from defectors from the Nationalist *Brigada Saltillo*)

##### **Yucatan**

*Tercio Cuauhtemoc*: 700 men, 4 AFVs (formerly *Brigada*

*Gutierrez* of the Nationalist Army)

##### **Southwestern New Mexico**

*Tercio Torreon*: 600 men, 1 AFVs (formerly *Brigada Torreon* of the Nationalist Army)

#### **MARAUDERS**

##### **Southern Texas**

*Bandera Matamoros*: 300 men (Brownsville) (nominally Nationalist)  
*Bandera Rodriguez*: 200 men (Kingsville) (formerly Nationalist *Brigada Victoria*)

##### **Central Mexico**

*Brigada Aguascaliente*: 1,200 men, 2 AFVs (now broken up into numerous small *banderas*)  
*Bandera Zapata*: 800 men, 1 AFV (remnants of the former Nationalist *Brigada Puebla*)  
*Bandera Morelia*: 500 men (formerly Nationalist *Brigada Morelia*, now nominally Alliance)

##### **Southern California**

*Brigada Tepic*: 1000 men, 1 AFV (now broken up into numerous small *banderas*)  
*Brigada Ensenada*: 800 men (now broken up into numerous small *banderas*)

##### **New Mexico**

*Brigada Ciudad Juarez*: 600 men (now broken up into numerous small *banderas*)

##### **Yucatan**

*Brigada Merida*: 300 men (now broken up into numerous small *banderas*)  
 —Frank A. Chadwick

#### **ULSTER IMPORTS, LTD.**

PO Box 1748  
 Champaign IL

Makes available 20mm figures from Platoon 20, for use with *Twilight: 2000*

MODERN U.S. INFANTRY  
 and  
 MODERN SOVIET INFANTRY

Send SASE for list or \$1.00 (check or money order) for list and a sample figure.

**Warning:** Figures contain lead and are not recommended for children under 12.

*Twilight: 2000* is a trademark of Game Designers' Workshop.

# The Inland Waterway: Supplemental Material for Red Star/Lone Star



This article presents supplementary material to GDW's **Twilight: 2000** module *Red Star/Lone Star*. It gives players of that particular scenario another means of travel, and provides more information and rumors for the PCs to work with in accomplishing their goal.

## BACKGROUND

This article describes travel along the Intracoastal Waterway between Port Lavaca and Brownsville, a strip of water sheltered from the Gulf of Mexico by a string of low, narrow, sandy islands. It affords a relatively quick and easy way to travel along the Gulf Coast. Conversely, there will be fewer encounters and less chances to pick up rumors and information from the locals.

## TRAVEL AND COMBAT

Obviously, travel along the Intracoastal Waterway is possible only by boat. The characters will be presented with several opportunities to find a boat: in Port Lavaca, in Aransas Pass near Corpus Christi, in Baffin Bay near Kingsville, and in Brownsville.

The **Twilight: 2000** supplement *Pirates of the Vistula* gives rules for movement and combat involving boats. The referee should be able to construct an appropriate vessel from this module.

The referee should use the map provided with *Red Star/Lone Star* to chart the characters' movement along the Waterway. Use the map scale to estimate the distance covered based on the number of four-hour periods spent traveling and the speed of the boat.

This article describes features of, and gives encounter tables for, the entire length of the Intracoastal waterway from Port Lavaca to Brownsville. The referee can use this information to

add to the adventure, combining it with details given in the module for various areas ashore. For example, if the adventurers sail south from Port Lavaca, they may choose to land near Corpus Christi to engage LaMarr's marauders on land, or they may become involved in a firefight with the outpost on the JFK bridge to Padre Island.

## THE INTRACOASTAL WATERWAY

**Towns and landmarks:** Matagorda Island Airforce base, San Antonio Bay, Copano Bay, Aransas Pass, JFK Bridge, Padre Island, Baffin Bay, Port Mansfield, Brazos Santiago Pass and Lighthouse.

## RUMORS AND INFORMATION

**Rumor A:** There have been strange vessels prowling up and down the waterway lately, especially at night. There are rumors of strange signals, flares, flashing lights, and of bands of men slipping ashore in small boats. It could be the Russians getting ready to invade to support their army inland.

**Rumor B:** Something really strange is going on down Brownsville way. There have been stories about the Mexican army teaming up with marauders and a criminal syndicate—the Huerra-Gonzales family—for some really big project.

**Rumor C:** They've found millions of gallons of oil in storage tanks down in Brownsville. It must've been overlooked by the Americans when they pulled out and the Mexicans when they marched in.

**Rumor D:** Grady LaMarr is one of the most feared of the marauder band leaders in the area. He's got something big going down in Brownsville.

**Rumor E:** Grady LaMarr has his own boat—a 70-foot oil rig motor launch he found and fixed up when he moved into Cor-



pus Christi. It's said he has the cannon off an old tank mounted aboard, and that he's blown fishing trawlers clean to match-wood with it.

**Rumor F:** The Russians are in Brownsville. Maybe they're going to use it as a port to bring in more troops.

**Rumor G:** Colonel Rodriguez, the leader of a big, mean marauder band in Kingsville, has been murdered. His second-in-command is worse than he is, so things'll be getting a mite lively down Kingsville way.

**Rumor H:** The pirate Jean Lafitte buried a fortune in plundered treasure somewhere on Padre Island underneath a millstone inscribed with the words "dig deeper." That treasure has never been found.

**Rumor I:** Some rough types down Brownsville way have been living high lately. In Port Lavaca, which has a silver-based economy, they were turning in bar silver for script and spending a fortune on food, drink, and women. Elsewhere, they've been spreading trade goods around and acting like big spenders. Where'd they get a stake like that?

**Rumor J:** Fishing and shrimping boats have been vanishing in the Laguna Madre. Some say it's the Russians...maybe with their submarines. Others say there's a monster in the Madre...some great, hungry mutant spawned by the radiation from Galveston and Corpus Christi.

#### GENERAL ENCOUNTER TABLE

2D6	Results
2	No encounter
3	Wreck
4	No encounter
5	No encounter
6	Fishing/shrimp boat
7	No encounter
8	No encounter
9	Shore sighting
10	Danger!
11	Attack
12	Fishing/shrimp boat
13	Wreck
14	Freighter

Roll 2D6 once each period the boat is under way. If roll is made near Port Lavaca or Brownsville, implement a DM of +2.

#### ENCOUNTERS

**Fishing/Shrimp Boat:** The characters sight a fishing vessel under way. Its crew of 2D6+2 men will be wary but willing to heave to and talk or trade if approached cautiously. A conversation allows two rolls on the rumors table for the Waterway. If attacked, the crew will defend themselves vigorously with rifles, shotguns, and automatic weapons.

**Shore Sighting:** The referee determines the nature of the sighting depending on the area the vessel is passing. A roll can be made on that area's encounter table, or the referee can arbitrarily determine what is seen. Possible sightings include typical shore encounters such as: game, civilians, *refugiados*, marauders, or troops. NPCs sighted ashore may, at the referee's

#### TABLE OF RUMORS AND INFORMATION

2D6	Results
2	Rumor A
3	Rumor B
4	Rumor C
5	Rumor D
6	Rumor E
7	Rumor F
8	Rumor G
9	Rumor H
10	Rumor I
11+	Rumor J

GDW LIBRARY

discretion: open fire on the boat; hail the characters in order to talk, request help, or ask for a ride; or ignore them. Soldiers might try to requisition the boat for their own use.

**Danger!:** Like the danger category for shore encounters, this refers to any of a large number of possible accidents or dangers. In this case, however, the threat is aboard ship or afloat. Possible dangers at sea include:

- The boat, old and rusty, has sprung a leak and is sinking.
- The boat suffers a collision with a submerged rock and is sinking.
- The boat runs aground on a sand bar.
- A storm threatens.
- Stacked cargo shifts with a swell and falls on someone.
- The boat's engine dies and the vessel drifts aground.
- An early morning fog makes cruising hazardous.

Both the nature and the ease of resolution of the danger are left to the referee. In many cases the problem will be simple, the danger slight or nonexistent, but they should serve to complicate things for the players.

One of the greatest dangers which can threaten a small craft at sea is a storm. The approach of a storm should be presented dramatically, allowing the characters to watch it building up over a period of hours. The danger from a storm will be far less if the characters can anchor inside a sheltered bay, but there will still be a chance of breaking an anchor line, of running aground, or of being swamped.

**Attack:** The vessel comes under attack. At the referee's option this could be an attack from shore with hidden marauders firing on the boat in an attempt to make it run aground, or it could be an attack from a marauder-crewed vessel—possibly one disguised as a harmless fishing trawler. Another possibility is the approach of a motor launch similar to the characters' vessel, manned by Mexican soldiers.

**Wreck:** The characters sight a wreck. This could be a grounded vessel or one which has sunk in shallow and protected water with the superstructure still above water. It could also refer to a vehicle or building close to the shore, abandoned and in poor repair. At the referee's discretion, the wreck, whatever its nature, could be a source of spare parts for repairs to the engine or other machinery aboard—such as the still. Characters should use SCR skill to locate needed parts.

**Freighter:** The characters sight a freighter—possibly the *Sao Sebastiao* or another like her. The ship will be leaving or entering a nearby port and will not stop for the characters. At night, twilight, or in a fog, the characters' vessel will be in danger of being rammed and sunk.

#### MATAGORDA ISLAND/MATAGORDA ISLAND AIR FORCE BASE

Matagorda Island is a 55-kilometer-long strip of sand dunes and grass enclosing Espiritu Santo Bay. It is 22 km from Port Lavaca to Port O'Connor (now abandoned) at Cavallo Pass, and another 18 km to Matagorda Island Airforce Base at the northern end of Matagorda Island.

The island is now completely deserted. The air base was stripped and blown up when U.S. forces retreated from the area. Nothing remains but crumbling brick shells and the charred frameworks of empty Quonset huts and hangars.

Characters may, at the referee's discretion, search the ruins for small bits of machinery or equipment which might prove useful. Examples include: lengths of pipe or tubing, valves, or

plumbing fixtures or fittings, a small electric generator, space heaters, first aid kits, maps of the area, nails, tools, hand carts, or cargo pallets. There is a great deal of debris scattered among the burned-out buildings, and with enough time to search, almost any reasonable artifact could be found. Weapons, fuel, explosives, vehicles, or more than a few stray ammunition magazines will *not* be found, however.

The island itself is desolate, exposed, and deserted.

#### SAN ANTONIO BAY

San Antonio Bay is an enclosed and shallow bay sheltered from the Gulf by Matagorda Island. The mouth of the bay is 20 km from Matagorda Island Air Force Base. The area is inhabited by ranchers and farmers, many of them Grange members, most of them willing to trade or exchange news. Make two rolls on the rumor table included in this article for each contact. Characters will find game on a 2D6 roll of 2 or 3 made each 4 hours they are out, or it will be an AVG:RCN task to hunt and kill it.

Make one roll on the general encounter table (Intracoastal Waterway) each eight hours the characters remain anchored in the bay. Treat *wreck* as *no* encounter.

The southern headland of San Antonio Bay is the Aransas National Wildlife Reserve, described on page 21 of *Red Star/Lone Star*. The referee should refer to that entry if the characters put ashore here.

#### COPANO BAY

The mouth of Copano Bay lies 35 km south from San Antonio Bay, almost hidden behind narrow peninsulas of land which nearly cut it off from Aransas Bay. The cove is sheltered by San Jose Island, which is as deserted as nearby Matagorda Island.

Copano Bay is the site of the capture of three Spanish cargo vessels by a mounted detachment of Rangers during the Mexican Revolution...the origin of the old joke about Horse Marines. It is also supposed to be one of the hideouts used by the pirate Jean Lafitte. Before the current war began, it was a recreational area renowned for its excellent hunting and fishing.

State Highway 35 runs across the mouth of Copano Bay on a causeway, but there is a bridge span under which vessels such as the characters' launch can pass.

Use the general encounter table in this article while the characters are aboard their boat in Copano Bay. Make 1 roll for each 8 hours they are anchored, and treat *Wreck* as *No Encounter*. Use the general encounter table of section 1 (*Red Star/Lone Star*, page 16) for forays ashore to hunt or to trade with the local inhabitants.

There is plentiful fish and game in the area. Finding it is an ESY:FSH or ESY:RCN task.

#### ARANSAS PASS

The port of Aransas Pass is 20 km south of the mouth of Copano Bay. This town is described more fully in *Red Star/Lone Star* (pages 27-28), and that description can be used if the characters arrive at Aransas Pass by boat.

Aransas Pass is joined by a bridge and causeway with Harbor Island, which is mostly swamp. A ferry once connected Harbor Island with the town of Port Aransas at the northern

tip of Mustang Island. A lighthouse stands on Harbor Island, abandoned but still intact.

#### MUSTANG ISLAND/PORT ARANSAS

Mustang Island is 21 km long and stretches across the mouth of Corpus Christi Bay. A road runs the entire length of the island.

Mustang Island was once a vacation and recreational area. Much of Port Aransas was devoted to beachfront motels and the tourist industry. An airfield and a Coast Guard Station lay on the outskirts of the town. Farther south, Mustang Island State Park was the recreational playground for millions of Texans and tourists every year.

The entire island is completely deserted now. Both the airfield and the Coast Guard Station were looted and partly burned when the area was evacuated, and there was some damage from the Corpus Christi firestorm, but the referee may allow the characters to find sought-after machine parts, tools, or other small items *other than* weapons, fuel, or ammo in the town, station, or airfield.

Since the road on Mustang Island connects with the JFK Causeway, the characters may consider using Port Aransas or Mustang Island as a base from which to attack the Causeway or the marauder camp at Corpus Christi Naval Air Station.

There is no game on the island, but fishing is an ESY:RCN task.

#### JFK CAUSEWAY

This bridge and causeway connects the road to the Corpus Christi Naval Air Station with the northern tip of Padre Island. The causeway is guarded by marauders armed with light automatic weapons, grenade launchers, and an M60 machinegun. The causeway and its defenses are described in *Red Star/Lone Star* (page 28), and the referee should refer to that description if the characters attempt to cross it by boat or land.

The causeway itself is 8 km long, and the mainland end is 3 km south of the Naval Air Station. The causeway road splits at the northern end of Padre Island, one fork going south along the length of Padre Island, the other going north across shallow channels and swampy land to Mustang Island.

#### PADRE ISLAND

Padre Island is 180 km long, and for its entire length it is five kilometers wide or less. It is a desolate, windswept expanse of beach, sand, and dune grass—literally a desert island.

Before the war, most of the island was part of the Padre Island National Seashore. A paved road extends 14 kilometers south from the JFK Causeway. Beyond that there is only sand. Tracked or four-wheel drive vehicles are necessary to negotiate the terrain. The entire island is deserted.

One hundred forty km south from the causeway there is a man-made break in the island opposite the ruins of Port Mansfield. The narrow strip of sand south of this break is called South Padre Island. It too is deserted.

#### BAFFIN BAY

The mouth of Baffin Bay lies 40 km south of the JFK  
*continued on page 22*

# Target 2000: The "Hit List" for WWII

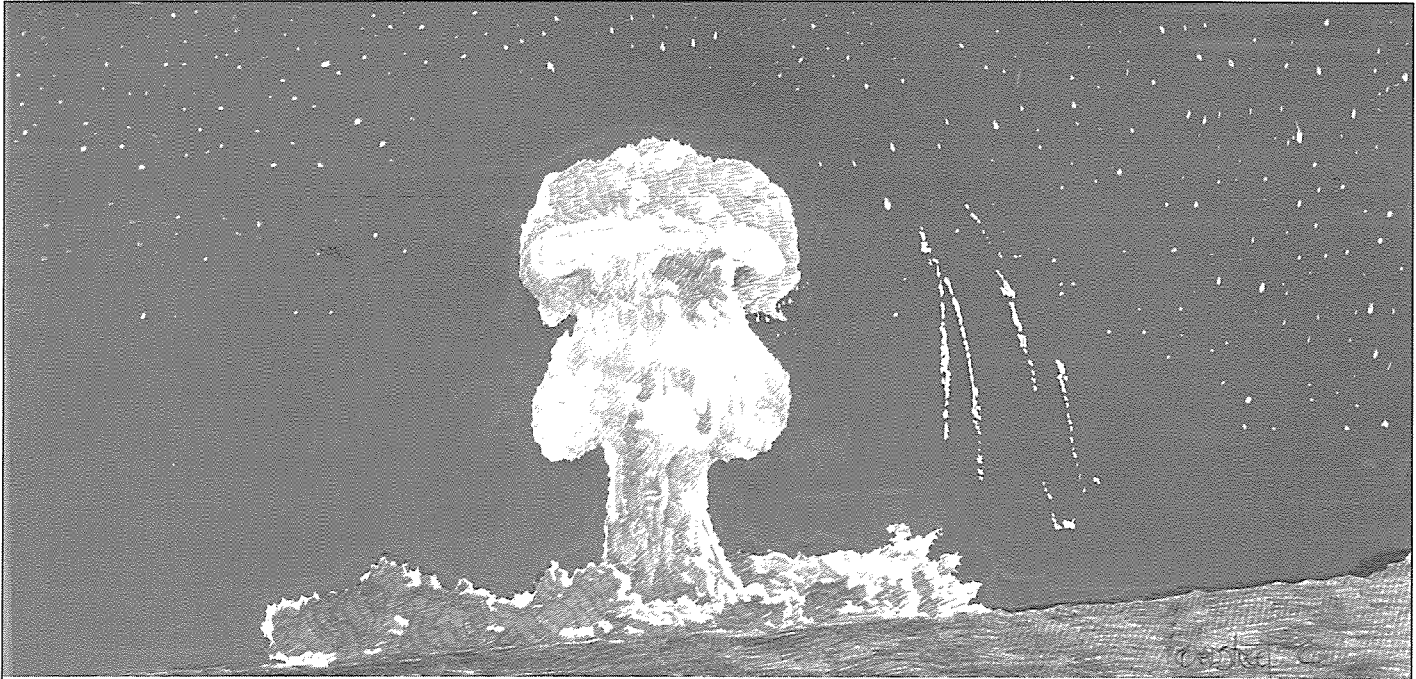

Players and referees of **Twilight: 2000** are understandably curious to know the specifics of the nuclear attack on the United States in the last quarter of 1997. This article contains a state-by-state breakdown of the major target points, along with notes on why each particular location was a target. The severity of the attack on each target point is represented by the megaton (Mt) rating of the weapons exploded there (not necessarily as a single weapon). With certain exceptions, only places that received .5 megaton or more are covered here. All detonations are air bursts unless otherwise noted.

The target list was determined based on information contained in the Office of Technology Assessment's 1979 study "The Effects of Nuclear War," supplemented by other sources. Primary targets included oil refining and storage facilities, oil distribution facilities, military and civilian command centers, and certain key industrial areas. Secondary and tertiary targets included electrical generation plants (nuclear, hydroelectric, and conventional) and lesser industrial facilities. Major population centers were not targets in and of themselves, but many sustained damage because of their proximity to targeted installations. Likewise, only the central command and control facilities of missile and bomber wings were targeted, not the individual weapon silos or hangers.

## EFFECTS

Total casualties in the attack were 135.2 million, or 52% of the population of the United States in 1997. This includes both initial fatalities and subsequent deaths from injuries, in addition to deaths from disease, starvation, and civil unrest up to July 2000.

The exclusion of a city from this list does not mean that it is intact. Civil unrest, hostile military action, and other factors

have caused severe damage in regions otherwise untouched by the war. For example, the Alaska Pipeline and the oil storage facilities at Valdez Bay and the North Slope were damaged during the Soviet invasion of Alaska, and are currently inoperable, even though they were not targets of nuclear bombs.

The main effect of the attack was the destruction of over 60% of the country's oil refining capacity. This, in combination with the other destruction, effectively eliminated electrical power generation and industrial facilities. Food shortages, disease, and civil unrest following the strikes destroyed American society as it existed before the war.

## TARGET LIST

Geographic locations are given in terms of the nearest large city or the place most commonly associated with a particular target. Ground zero can be quite some distance from the center of the community listed. Alaska and Hawaii have been omitted from the map since there was only one strike in each of these states. Target points in Canada are not shown. The size of the dots used does not represent the area of damage for a particular location. State abbreviations are conventional, *AFB* stands for Air Force Base.

**Elmendorf AFB, AK:** Alaskan Air Command Headquarters (1 Mt).

**Blytheville AFB, AR:** 42nd Air Division Headquarters, 97th Strategic Bombing Wing (1 Mt).

**El Segundo, CA:** Oil refining and storage facilities (1.75 Mt).

**Richmond, CA:** Oil refining and storage facilities (one 1.5 Mt).

**Carson, CA:** Oil refining and storage facilities (.75 Mt).

**Avon, CA:** Oil refining and storage facilities (.5 Mt).

*continued on page 47*

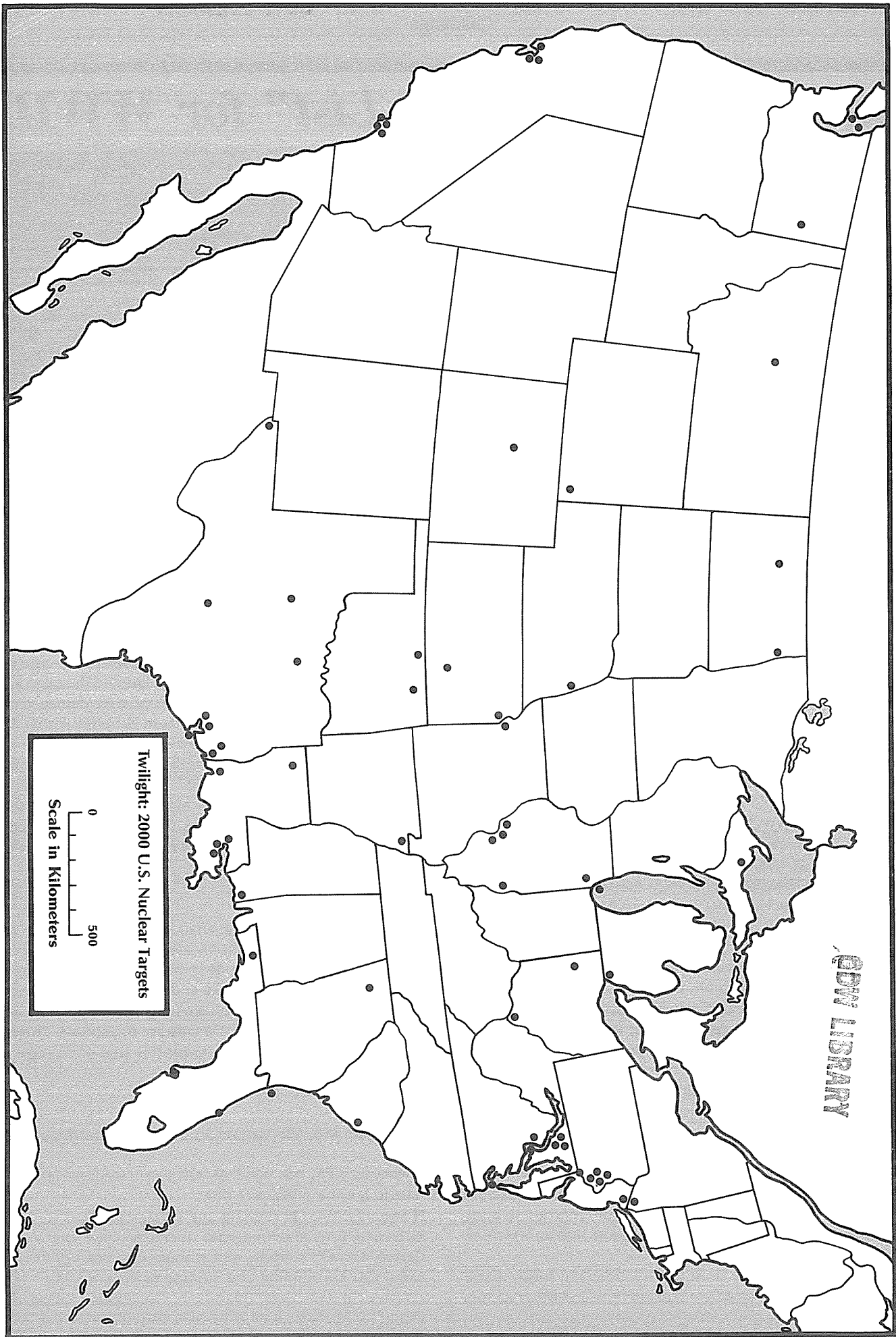

Twilight: 2000 U.S. Nuclear Targets

Scale in Kilometers

0 500

ODJ LIBRARY

## Twilight: 2000 Consolidated Price List

This listing is a consolidation of all prices for equipment contained in the basic game price list, the game errata, *The Free City of Krakow*, *U.S. Army Vehicle Guide*, *Red Star/Lone Star*, *Challenge 25* and *26*, and *The RDF Sourcebook*. It also contains the aircraft listings from the *Twilight Air Module* in *Challenge 26*, and the helicopters from *Going Home* and *The Free City of Krakow*.

This article is intended to be photocopied and used by the referee and the players as a consolidated reference (specific permission is given to copy this article for private use).

Note that not all of these items are likely to be available at any one location, and that exact price and availability must be determined by the referee in accordance with individual campaign conditions.

### WEAPONS

**Magazines:** Except where noted, the price for a magazine is \$1 per shot.

#### Bows

- Longbow: \$300 (C/C).
- Crossbow: \$350 (C/C).

#### Automatic Pistols

- 9mm Parabellum: \$150 (V/S).
- 9mm Makarov: \$150 (S/V).
- 7.62mm Tokarev: \$100 (R/C).
- .380 Automatic: \$100 (C/S).
- .22 Automatic: \$50 (C/C).
- .45 Automatic: \$100 (S/R).

#### Revolvers

- .38 Special Revolver: \$140 (R/R).

#### Submachineguns

- Sterling: \$600 (C/S).
- Uzi: \$500 (V/C).
- Ingram M10: \$350 (C/S).
- Mini-Uzi: \$600 (C/S).
- M231: \$300 (V/C).
- MP-5: \$400 (C/S).
- MP5SD: \$1,000 (C/S).
- CAR-15: \$750 (S/R).
- AKR: \$300 (S/C).
- Vz24: \$300 (R/S).
- Skorpion: \$250 (R/S).
- G11: \$400 (C/R).
- Viking SMG: \$1,000 (S/R).
- MAT-49: \$700 (S/R).
- AMD-65: \$1,000 (S/R).

#### Assault Rifles

- M16A2: \$400 (V/C).
- AKMR: \$300 (C/V).
- AK-74: \$300 (C/C).
- IW: \$500 (S/R).
- AKM: \$300 (C/V).
- FA-MAS: \$500 (R/R).
- Galil ARM: \$500 (C/S).
- Galil SAR: \$600 (C/S).
- Valmet M82: \$1,000 (S/R).

#### Battle Rifles

- FAL \$600 (S/R).
- G3: \$500 (C/R).

#### Sniper Rifles

- M40: \$700 (R/R).
- M21: \$400 (S/R).
- PSG1: \$600 (R/R).
- L42: \$400 (R/R).
- Parker-Hale: \$400 (R/R).
- SVD: \$500 (R/S).
- Vz54: \$300 (R/R).
- Galil Sniper Rifle: \$500 (S/R).
- FR-F2: \$1,000 (S/R).
- Barret 82: \$2,000 (R/R).

#### Sporting Rifles

- .30-30 Lever Action: \$250 (C/S).
- .30-06 Bolt Action: \$300 (C/S).
- .22 Bolt Action: \$150 (C/C).
- .22 Semi-Auto: \$100 (C/C).
- Mauser Bolt Action: \$150 (C/C).

#### Shotguns

- Double Barrel: \$200 (V/V).
- Pump: \$300 (V/C).
- HK CAW: \$800 (C/R).

#### Automatic Rifles

- M249: \$1,500 (S/R).
- LSW: \$1,500 (R/R).
- RPK-74: \$1,000 (S/C).
- I-Max 100: \$800 (S/R).

#### Melee Weapons

- Knife: \$5 (V/V).
- Bayonet: \$20 (C/C).
- Spear: \$10 (V/V).
- Club: \$0 (V/V).
- Hatchet: \$20 (V/V).
- Axe: \$50 (V/V).
- Machete: \$20 (C/C).

#### Machineguns

- M60: \$1,500 (S/R).
- M60E3: \$2,000 (S/R).
- MG3: \$1,700 (S/R).
- MAG: \$1,500 (S/R).
- PK: \$2,000 (R/S).

- Vz59: \$1,500 (R/R).
- AAT-52: \$400 (R/R).
- BRG-15: \$3,000 (S/R).
- NSV: \$4,000 (R/S).
- HK-21: \$2,500 (S/R).

#### Heavy Machineguns

- M214: \$10,000 (R/R).
- M2HB: \$1,600 (V/C).
- DShK: \$2,000 (C/V).
- KPV: \$3,000 (S/C).

#### Grenade Launchers

- M203: \$500 (C/S).
- HK-69: \$500 (S/R).
- AGS-17: \$3,000 (R/S).
- Mark-19: \$5,000 (S/R).
- IMI MGL-40: \$1,200 (R/R).

#### Rocket Launchers

- M202: \$2,000 (S/R).
- RPG-16: \$1,000 (S/C).
- Armbrust: \$200 (S/R).
- B-300: (launcher) \$1,500 (C/S), (rocket) \$800 (C/S).
- LRAC 89: (launcher) \$2,000 (S/R), (rocket) \$800 (S/R).
- DARD 120: (launcher) \$3,500 (S/R), (rocket) \$1,000 (S/R).

#### Antitank Missile Launchers

- Tank Breaker: \$5,000 (S/R).
- AT-4: \$3,000 (S/C).
- TOW II: \$10,000 (S/R).
- AT-5: \$6,000 (R/S).
- Milan: \$3,000 (S/C).

#### Antiaircraft Missiles

- Chaparral (AGM87A): \$1,500 (S/R).
- Roland II: \$2,500 (R/R).
- FIM92B Stinger: \$1,200/case (R/R).

#### Large Caliber Guns

- 125mm (Rapira-3) Gun: \$50,000 (R/S).
- 20mm PIVAD (towed): \$75,000 (R/R).
- ZU-2: \$15,000 (S/C).
- ASP 30mm Autocannon: \$15,000 (S/R).
- 40mm Autocannon (towed): \$60,000 (S/R).
- 57mm S-60 Autocannon: \$40,000 (R/S).
- 100mm M1955 Gun (towed): \$40,000 (R/S).
- 130mm M1946 Gun (towed): \$75,000 (R/S).

#### Howitzers

- M202 105mm How (towed): \$50,000 (S/R).
- 122mm (D-30) Howitzer: \$50,000 (S/C).
- 155mm How: \$75,000 (S/R).

GDW LIBRARY

**Mortars**

60mm: \$5,000 (C/S).  
 81mm: \$10,000 (C/S).  
 82mm Vasilek: \$20,000 (R/S).  
 107mm (4.2') mortar: \$12,000 (C/S).  
 120mm: \$15,000 (C/C).

**TRIPODS**

NLT (Nato Light Tripod): \$200 (C/S).  
 NMT (Nato Medium Tripod): \$200 (S/R).  
 NHT (Nato Heavy Tripod): \$350 (C/S).  
 PLT (Pact Light Tripod): \$250 (S/C).  
 PMT (Pact Medium Tripod): \$300 (S/C).  
 PHC (Pact Heavy Carriage): \$1,000 (R/S).

**AMMUNITION****Small Arms & Machinegun**

Longbow Arrow: \$50/24 (C/C).  
 Crossbow Bolt: \$30/24 (C/C).  
 4.7 Cls: \$1,300/case of 600 (S/R).  
 5.45 B: \$100/case of 280 (C/V).  
 5.56 N: \$100/case of 280, \$200/335-shot drum (V/C).  
 .22 LR: \$225/case of 1,600 (C/S).  
 7.62 T: \$250/case of 840 (R/S).  
 7.62 S: \$80/case of 220 (S/C).  
 .30-30: \$170/case of 300 (C/S).  
 7.62 N: \$65/case of 200 or 165 belted (C/S).  
 7.62 L: \$70/case of 200 or 165 belted (S/C).  
 .30-06: \$80/case of 150 (S/R).  
 .32 ACP: \$150/case of 800 (S/S).  
 8mm M: \$30/case of 100 (S/S).  
 .380 ACP: \$125/case of 480 (C/S).  
 9mm M: \$200/case of 480 (S/C).  
 9mm P: \$225/case of 480 (V/C).  
 .38 Special: \$175/case of 300 (S/R).  
 .45 ACP: \$63/case of 300 (S/R).  
 12.7 B: \$35/case of 34 belted (S/C).  
 .50 BMG: \$35/case of 35 belted (C/S).  
 .50 SLAP: \$60/case of 35 belted (S/R).  
 14.5 B: \$30/case of 33 belted (S/C).  
 15 SLAPI or BMG: \$40/belt of 33 (S/R).  
 12 Gauge: \$100/case of 240 (C/C).

**Hand Grenades**

Fragmentation: \$4, \$100/case of 30 (C/C).  
 CHEM (HC Smoke): \$3, \$40/case of 16 (C/S).  
 CHEM (Irritant Gas): \$6, \$80/case of 16 (S/R).  
 Antitank: \$10, \$120/case of 15 (R/S).  
 Concussion: \$4, \$70/case of 20 (C/S).  
 Thermite: \$10, \$140/case of 16 (S/R).  
 WP: \$20, \$280/case of 16 (S/S).

**Grenade Launcher Rounds**

30mm HE: \$3, \$75/29-shot drum (R/C).  
 40mm HE: \$4, \$200/case of 72 (C/S).  
 40mm HEDP: \$5, \$250/case of 72 (S/R).

40mm CHEM (Irritant Gas): \$4, \$150/case of 44 (S/R).  
 40mm ILLUM: \$6, \$225/case of 44 (S/R).  
 40mm HVHE: \$6, \$250/case of 50 belted (S/R).  
 40mm HVHEDP: \$10, \$400/case of 50 belted (S/R).

**Rockets**

58.3mm HEAT: \$50, \$125/case of 3 (R/S).  
 66mm HEAT: \$250/4-shot clip (S/R).  
 66mm WP: \$400/4-shot clip (S/R).  
 122mm HE: \$600 each (R/S).  
 140mm HE: \$800 each (R/S).  
 160mm HE: \$2,500/case (R/R).  
 160mm ICM: \$2,500/case (R/R).  
 160mm CHEM: \$2,500/case (R/R).  
 227mm HE: \$3,000/case (R/R).  
 227mm ICM: \$3,000/case (R/R).  
 227mm ILLUM: \$3,000/case (R/R).  
 227mm CHEM: \$3,000/case (R/R).

**Rifle Grenades**

HEAT: \$12, \$100/case of 10 (S/R).  
 WP: \$25, \$200/case of 10 (S/R).  
 140mm RAW HE: \$50 (S/R).  
 140mm RAW HEAT: \$100 (S/R).

**Antitank Missiles**

Tank Breaker: \$1,000 (S/R).  
 TOW II: \$1,500 (S/R).  
 Hellfire: \$2,000 (S/R).  
 ADATS: \$2,500 (R/R).  
 AT-4: \$750 (R/S).  
 AT-5: \$1,200 (R/S).  
 Milan: \$750 (R/S).

**Large Caliber Rounds**

20mm HE: \$450/case (S/R).  
 20mm AP: \$450/belt (S/R).  
 23mm API: \$500/case of 33 belted (S/C).  
 23mm HE: \$500/case of 33 belted (S/C).  
 25mm API: \$650/case of 33 belted (C/S).  
 25mm HE: \$650/case of 33 belted (C/S).  
 25mm APFSDSDU: \$2,500/case of 33 belted (S/R).  
 25mm Oerlikon HE: \$500/case (R/R).  
 25mm Oerlikon AP: \$500/case (R/R).  
 30mm API: \$750/case of 33 belted (S/C).  
 30mm HE: \$750/case of 33 belted (S/C).  
 30mm Bofors HE: \$520/case (R/R).  
 30mm Bofors AP: \$520/case (R/R).  
 40mm HE: \$6,000/case of 64 (C/S).  
 40mm HEPXPF: \$8,000/case of 64 (R/R).  
 57mm APFSDS: \$400/case of 4 (R/R).  
 57mm APHE: \$400/case of 4 (R/R).  
 57mm HE: \$400/case of 4 (R/R).  
 60mm APFSDS: \$300/case of 3 (R/R).  
 60mm HE: \$300/case of 3 (R/R).  
 75mm HE: \$250 (C/S).

75mm WP: \$500 (R/R).  
 75mm APFSDS: \$600 (S/R).  
 76.2mm APFSDS: \$600 (R/S).  
 76.2mm HE: \$600 (R/S).  
 76.2mm HEAT: \$600 (R/S).  
 90mm APDS: \$500 (R/R).  
 90mm HE: \$500 (R/R).  
 90mm HEAT: \$500 (R/R).  
 90mm APERS: \$500 (R/R).  
 90mm WP: \$500 (R/R).  
 100mm HE: \$550 (R/R).  
 100mm HEAT: \$550 (R/R).  
 100mm APHE: \$550 (R/R).  
 100mm APC: \$550 (R/R).  
 105mm HEAT: \$600 (C/S).  
 105mm APFSDS: \$600 (S/R).  
 105mm APFSDSDU: \$1,000 (R/R).  
 105mm WP: \$1,000 (R/R).  
 120mm HEAT: \$800 (C/S).  
 115mm APDS: \$700 (R/R).  
 115mm HEAT: \$700 (R/R).  
 120mm APFSDS: \$800 (S/R).  
 120mm APFSDSDU: \$1,500 (R/R).  
 120mm WP: \$1,000 (R/R).  
 120mm L11A5 APDS: \$1,200 (R/R).  
 120mm L11A5 HEAT: \$1,100 (R/R).  
 125mm HE: \$800 (S/C).  
 125mm HEAT: \$800 (R/S).  
 125mm APFSDS: \$800 (S/R).  
 125mm APFSDSDU: \$1,500 (R/R).  
 125mm Powder Charge: \$80 (S/C).  
 130mm HEAT: \$850 (R/R).  
 130mm HE: \$850 (R/R).  
 130mm APFSDS: \$850 (R/R).  
 130mm CHEM: \$850 (R/R).  
 165mm HEP-T: \$2,000 (R/R).

**Howitzer Rounds**

105mm HE: \$600 (R/R).  
 105mm ICM: \$600 (R/R).  
 105mm WP: \$600 (R/R).  
 122mm HE: \$350 (S/C).  
 122mm HEAT: \$500 (R/S).  
 122mm ICM: \$2,000 (R/R).  
 122mm WP: \$700 (R/S).  
 122mm CHEM: \$350 (R/S).  
 122mm ILLUM: \$350 (R/R).  
 122mm Powder Charge: \$40 (C/V).  
 152mm HE: \$500 (S/C).  
 152mm HEAT: \$750 (R/S).  
 152mm ICM: \$3,000 (R/R).  
 152mm WP: \$1,000 (R/S).  
 152mm WP: \$1,000 (R/S).  
 152mm CHEM: \$500 (R/S).  
 152mm ILLUM: \$500 (R/R).  
 152mm Powder Charge: \$60 (C/V).  
 155mm HE: \$500 (C/S).  
 155mm HEAT: \$750 (C/S).  
 155mm ICM-DP: \$3,000 (R/R).  
 155mm WP: \$1,000 (S/R).

GDW LIBRARY

155mm CHEM: \$500 (S/R).  
 155mm ILLUM: \$500 (S/R).  
 155mm CLGP: \$5,000 (R/R).  
 155mm FASCAM: \$5,000 (R/R).  
 155mm Powder Charge: \$60 (V/C).  
 203mm HE: \$900(S/R).  
 203mm ICM: \$900 (S/R).  
 203mm ILLUM: \$900 (S/R).  
 203mm CHEM: \$900 (S/R).  
 203mm WP: \$900 (S/R).  
 203mm Powder Charge: \$600 (S/R).

#### Mortar Rounds

60mm HE: \$300/case of 12 (C/S).  
 60mm WP: \$600/case of 12 (S/R).  
 60mm ILLUM: \$300/case of 12 (S/R).  
 81mm HE: \$150/case of 3 (C/S).  
 81mm WP: \$300/case of 3 (S/R).  
 81mm ILLUM: \$150/case of 3 (S/R).  
 82mm HE: \$300/5-shot clip (S/C).  
 82mm HEDP: \$600/5-shot clip (R/S).  
 82mm WP: \$300/case of 3 (R/S).  
 82mm ILLUM: \$150/case of 3 (R/S).  
 4.2" HE: \$200/case of 2 (C/S).  
 4.2" ICM-DP: \$2,000/case of 2 (R/R).  
 4.2" WP: \$400/case of 2 (S/R).  
 4.2" CHEM: \$200/case of 2 (S/R).  
 4.2" ILLUM: \$200/case of 2 (S/R).  
 120mm HE: \$200/case of 2 (V/V).  
 120mm WP: \$400/case of 2 (S/S).  
 120mm CHEM: \$250/case of 2 (S/S).  
 120mm ILLUM: \$200/case of 2 (S/R).

#### VEHICLES

##### Unarmored Cargo Vehicles

Bicycle: \$1,000 (V/V).  
 Civilian Car: \$6,000 (V/V).  
 HMMWV (Hum-Vee): \$20,000 (C/S).  
 HMMWV FSV: \$30,000 (C/S).  
 FAV (Fast Attack Vehicle): \$15,000 (R/R).  
 UAZ-469: \$8,000 (S/C).  
 Renault VLM: \$5,000 (C/S).  
 Land Rover LWB: \$8,000 (C/S).  
 Motorcycle: \$5,000 (V/V).  
 ¼-ton truck: \$15,000 (C/S).  
 2½-ton truck: \$15,000 (C/C).  
 5-ton truck: \$20,000 (S/S).  
 8-ton truck: \$30,000 (S/S).  
 ¾-ton truck: \$10,000 (S/S).  
 Wagon: \$1,000 (V/V).  
 Cart: \$500 (V/V).  
 5,000-liter (5-ton) tank truck: \$15,000 (C/C).  
 10,000-liter (10-ton) tank truck: \$25,000 (S/S).  
 1-ton cargo trailer: \$1,000 (V/V).  
 1,000-liter (1-ton) tank trailer: \$1,000 (V/V).  
 M548 6-ton Cargo Carrier: \$50,000 (S/R).  
 M648 10-ton Cargo Carrier: \$250,000 (S/R).

##### Armored Personnel Carriers

M2 Bradley: \$200,000 (S/R).  
 M2A3 Bradley II: \$200,000 (S/R).  
 M3 Devers: \$200,000 (S/R).  
 M113: \$75,000 (S/R).  
 M113A3: \$75,000 (S/R).  
 M113A3 ACCV: \$75,000 (S/R).  
 M115A1 ACCV: \$75,000 (S/R).  
 Commando V-150: \$70,000 (S/R).  
 AAVP9: \$80,000 (R/R).  
 BMP-B: \$150,000 (R/S).  
 BMP-C: \$175,000 (R/S).  
 BTR-70: \$75,000 (S/C).  
 OT-64: \$80,000 (S/C).  
 FV 103 Spartan: \$70,000 (S/R).  
 MCV-80: \$250,000 (S/R).  
 Ze'ev IFV: \$15,000 (R/R).  
 AMX-10P: \$100,000 (S/R).  
 EE-11 Urutu: \$50,000 (R/R).

##### Light Combat Vehicles

LAV-25: \$100,000 (S/R).  
 LAV-75: \$250,000 (R/R).  
 M577A1 CP: \$90,000 (S/R).  
 Peacekeeper Armored Car: \$35,000 (S/R).  
 M750 AC: \$50,000 (S/R).  
 Commando AC: \$85,000 (S/R).  
 Commando 90 AC: \$95,000 (S/R).  
 Scorpion Mk 2/90: \$90,000 (S/R).  
 Scimitar Mk 2 (I): \$80,000 (S/R).  
 Fox AC: \$50,000 (S/R).  
 EE-3: \$25,000 (S/R).  
 EE-9 AC: \$70,000 (R/R).  
 Ramta RAM Mk5: \$30,000 (S/R).  
 Ze'ev MAGS: \$200,000 (S/R).  
 Ze'ev MAGS-60: \$180,000 (S/R).  
 Ze'ev MAGS/AA: \$150,000 (S/R).  
 AML-90: \$40,000 (R/R).  
 AMX-10RC: \$100,000 (R/R).  
 BT-76: \$70,000 (R/S).  
 BT-57: \$75,000 (R/S).  
 BRDM-3: \$50,000 (S/C).  
 OT-65: \$45,000 (S/C).

##### Engineer Vehicles

M728 CEV: 600,000 (R/R).  
 M1 AVLB: \$200,000 (R/R).  
 M60 AVLB: \$175,000 (R/R).

##### Main Battle Tanks

M1: \$600,000 (R/R).  
 M1A1: \$650,000 (R/R).  
 M1A2 Abrams III (Giraffe): \$700,000 (R/R).  
 M60A4: \$400,000 (S/R).  
 Cadillac Gage Stingray: \$800,000 (R/R).  
 T-72: \$400,000 (R/R).  
 T-80: \$500,000 (R/R).  
 T-90: \$600,000 (R/R).

T-55A: \$200,000 (R/S).  
 T-62M: \$300,000 (R/S).  
 Leopard III: \$700,000 (R/R).  
 AMX-40: \$500,000 (R/R).  
 AMX-30S: \$400,000 (R/R).  
 Chieftain Mk8: \$600,000 (R/R).  
 Challenger Mk1: \$600,000 (R/R).  
 Challenger MkIIA: \$850,000 (R/R).  
 Vickers MBT Mk4: \$425,000 (R/R).  
 Vickers Valiant Mk1/120: \$750,000 (R/R).  
 Super Centurion: \$300,000 (S/R).  
 Merkava MkII: \$800,000 (S/R).  
 Merkava MkIII: \$900,000 (S/R).

##### Self-Propelled Artillery

LAV-PIVAD: \$100,000 (S/R).  
 M17 LAVAA: \$100,000 (R/R).  
 M18 Mortar Carrier: \$200,000 (S/R).  
 M48 Chaparral: \$150,000 (S/R).  
 M106 Mortar Carrier: \$75,000 (S/R).  
 M109A2: \$300,000 (R/R).  
 M110A2 SP: \$375,000 (R/R).  
 M691 Diana: \$700,000 (R/R).  
 M741A6 PIVAD: \$75,000 (R/R).  
 M757 Blazer: \$200,000 (R/R).  
 M901 ITV: \$75,000 (S/R).  
 M917 ADATS: \$225,000 (R/R).  
 M920 Hellfire AT Vehicle: \$200,000 (S/R).  
 M948 LARS: \$225,000 (S/R).  
 M975A3 Roland II: \$300,000 (R/R).  
 M990 ADA: \$250,000 (R/R).  
 M993 MLRS: \$250,000 (R/R).  
 M988: \$100,000 (R/R).  
 MPGS-90: \$250,000 (R/R).  
 SAU-122: \$200,000 (R/R).  
 SAU-152: \$250,000 (R/R).  
 ZSU-30-6: \$100,000 (R/R).  
 SA-9 Gaskin: \$40,000 (R/S).  
 SA-13 Gopher: \$50,000 (R/R).  
 SU-130: \$250,000 (R/S).  
 BM 21: \$45,000 (S/C).  
 BM 14: \$25,000 (R/S).  
 Crotale: \$35,000 (R/S).  
 Rapier: \$45,000 (R/R).

##### Helicopters

Mi-17 Hip H: \$600,000 (R/R).  
 Mi-26 Halo: \$3,500,000 (R/R).  
 Mi-27 Hind E: \$750,000 (R/R).  
 Mi-28 Havoc: \$1,000,000 (R/R).  
 PZL W-3 Sokol: \$100,000 (R/R).  
 OH-58 AHIP: \$120,000 (R/R).  
 UH-60 Blackhawk: \$500,000 (R/R).  
 AH-64 Apache: \$1,000,000 (R/R).  
 530 MG Defender: \$130,000 (R/R).  
 AH-1V King Cobra: \$75,000 (R/R).  
 CH-53F: \$2,500,000 (R/R).  
 AS 355 Ecureuil 2: \$150,000 (R/R).  
 SA 365M Dauphin 2: \$750,000 (R/R).  
 SA 330H Puma: \$500,000 (R/R).

SA 341F/M Gazelle: \$750,000 (R/R).  
Westland 30-300: \$750,000 (R/R).  
Westland Lynx-3: \$1,000,000 (R/R).  
MBB/Kawasaki BK 117: \$200,000 (R/R).  
MBB BO-105 CB/P: \$125,000 (R/R).

#### Aircraft

AN-26: \$2,000,000 (R/R).  
MIG-29 Fulcrum: \$2,500,000 (R/R).  
SU-25 Frogfoot: \$2,500,000 (R/R).  
C-23A: \$2,000,000 (R/R).  
F-16C: \$5,000,000 (R/R).  
F/A-18: \$5,500,000 (R/R).

#### ANIMALS

Horse (broken): \$2,000 (S/S).  
Horse (unbroken): \$1,000 (S/S).  
Mule: \$600 (S/S).  
Ox: \$600 (C/C).

#### MISCELLANEOUS EQUIPMENT

##### Explosives

Dynamite Stick: \$10, \$750/case of 100 (C/C).  
Plastic Explosive Block: \$30, \$650/case of 20 (S/R).  
Mine, Antipersonnel: \$50, \$200/case of 4 (C/C).  
Mine, Anti-Tank: \$100, \$200/case of 2 (S/S).  
Mine, Claymore: \$250, \$800/case of 6 (S/R).  
Engineer Demo Kit: \$750 (C/C).

##### Generators

1.5 kilowatt: \$200 (C/C).  
5 kilowatt: \$700 (C/C).  
10 kilowatt: \$1,200 (S/S).  
60 kilowatt: \$8,000 (S/S).  
100 kilowatt: \$15,000 (R/R).  
500 kilowatt: \$50,000 (R/R).

##### Stills

Small: \$500 (V/V).  
Medium: \$2,500 (V/V).  
Large: \$200,000 (C/C).

##### Heaters & Coolers

Freezer, small: \$100 (S/S).  
Freezer, large: \$1,000 (S/S).  
Portable Heater: \$200 (C/C).  
150 liter water heater: \$1,500 (C/C).  
Refrigerator, small: \$100 (C/C).  
Refrigerator, large: \$1,000 (S/S).  
Field Cooker, military: \$1,000 (C/C).

##### Hand Tools

Basic Tool Kit: \$200 (V/V).  
Power Hand Tools: \$500 (C/C).  
Wheeled Vehicle Tools: \$500 (C/C).

Tracked Vehicle Tools: \$1,000 (S/S).  
Aircraft Tools: \$2,000 (R/R).  
Excavating Tools: \$300 (V/V).  
Construction Tools: \$500 (C/C).  
Small Arms Tools: \$200 (S/S).  
Heavy Ordnance Tools: \$750 (S/S).  
Electrical Repair: \$500 (C/C).  
Electronic Repair: \$1,000 (S/S).  
Arc Welder: \$500 (S/S).  
Portable Machine Shop: \$75,000 (R/R).  
Lockpick Tools: \$20 (V/V).

##### Radios

2 km Hand: \$250 (C/C).  
5/25 km Manpack/Vehicular: \$500 (S/S).  
5/25 km Secure Mp./Veh.: \$2,000 (R/R).  
50 km Vehicle: \$1,500 (S/S).  
50 km Secure Vehicle: \$6,000 (R/R).

##### Rangefinders

Portable Laser RF: \$1,000 (R/R).  
Vehicle Laser RF: \$1,500 (S/S).  
Portable Coincidence RF: \$500 (S/S).  
Vehicle Coincidence RF: \$7,000 (C/C).  
Vehicle Laser RF with Ballistic Computer: \$10,000 (R/R).  
Reticle Gunsight: \$10,000 (R/R).

##### Vision Devices

4x Binoculars: \$100 (V/V).  
25x Image Intensifier: \$2,500 (S/S).  
Starlight Scope: \$1,000 (R/R).  
IR Goggles: \$250 (C/C).  
IR Spotlight: \$150 (C/C).  
White Light Spotlight: \$100 (V/V).  
Thermal Sight: \$5,000 (R/R).

##### Radars

Ground Surveillance: \$40,000 (S/R).  
Mortar Counter-Battery: \$100,000 (S/R).  
Artillery Counter-Battery: \$200,000 (R/R).

##### Laser Designators

Man Portable: \$1,000 (S/R).  
Vehicle Mounted: \$2,000 (S/R).

##### NBC Equipment

Chemical Sniffer: \$500 (C/C).  
Optical Chemical Sensor: \$2,000 (S/R).  
Geiger Counter: \$500 (C/C).  
Gas Mask: \$150 (V/V).  
Steam Decontamination Trailer: \$5,000 (S/C).  
Chemical Defense Suit: \$1,000 (S/C).

##### Medical Supplies

Anesthetic, Total: \$1,000/100 units (R/R).  
Anesthetic, Local: \$1,000/100 units (R/R).  
Antibiotic, Liquid (+, -, & ±): \$500/100 units (R/R).

Antibiotic, Oral (+, -, & ±): \$750/100 units (R/R).

Anti-fever: \$500/100 units (R/R).  
Atropine, Liquid: \$500/100 units (R/R).  
Atropine Auto-Injector: \$75/10 (R/R).  
Pain-reliever, Mild: \$500/100 units (R/R).  
Sedative, Mild: \$500/100 units (R/R).  
Sedative, Strong: \$500/100 units (R/R).  
Blood, Whole: \$25/1 unit (S/S).  
Plasma: \$10/1 unit (S/S).  
Surgical Instruments: \$2,500 (R/R).  
Personal Medical Kit: \$100 (C/C).  
Doctor's Medical Kit: \$1,000 (S/S).

##### Food

MRE: \$8/kg (S/R).  
Domestic: \$4/kg (C/C).  
Wild: \$2/kg (C/C).

##### Fuel

Gas \$48 (R/R).  
Avgas \$60 (R/R).  
Diesel \$40 (R/R).  
Ethanol \$8 (C/C).  
Methanol \$4(V/V).

##### Body Armor

Kevlar Flak Jacket: \$800 (C/S).  
Plate Insert Jacket: \$400 (C/C).  
Ballistic Nylon Helmet: \$100 (C/S).  
Steel Helmet: \$50 (C/C).

##### Personal Gear

Fatigues: \$50 (V/V).  
Rucksack: \$20 (V/V).  
Flashlight: \$20 (C/C).  
Combat Webbing: \$10 (V/V).  
Shelter Half: \$25 (C/C).  
Sleeping Bag: \$50 (C/C).  
Thermal Fatigues: \$100 (S/S).  
Parka: \$150 (C/C).

##### Other Equipment

Blazer Reactive Armor: \$5,000 for 20 units (R/R).  
20-liter Jerrycan: \$25 (V/V).  
4-man Tent: \$100 (C/C).  
10-man Tent: \$250 (S/S).  
Bayonet: \$50 (V/V).  
Horse Tack: \$50 (C/C).  
Pack Saddle: \$40 (C/C).  
Aqualung: \$300 (C/C).  
Air Tank: \$100 (C/C).  
Rebreather: \$400 (R/R).  
Rebreather Recharge Kit: \$100 (R/R).  
Air Compressor: \$200 (R/R).  
Skis, Cross-Country: \$250 (C/C).

—Loren K. Wiseman



the  
**JOURNAL**  
of the Travellers' Aid Society®

GDW LIBRARY

Bestiary: The Oegongong  
*by Joe Fugate*

Grandfather's Worlds  
*by Marc W. Miller*

Chosen at Random  
*by Gary Thomas*

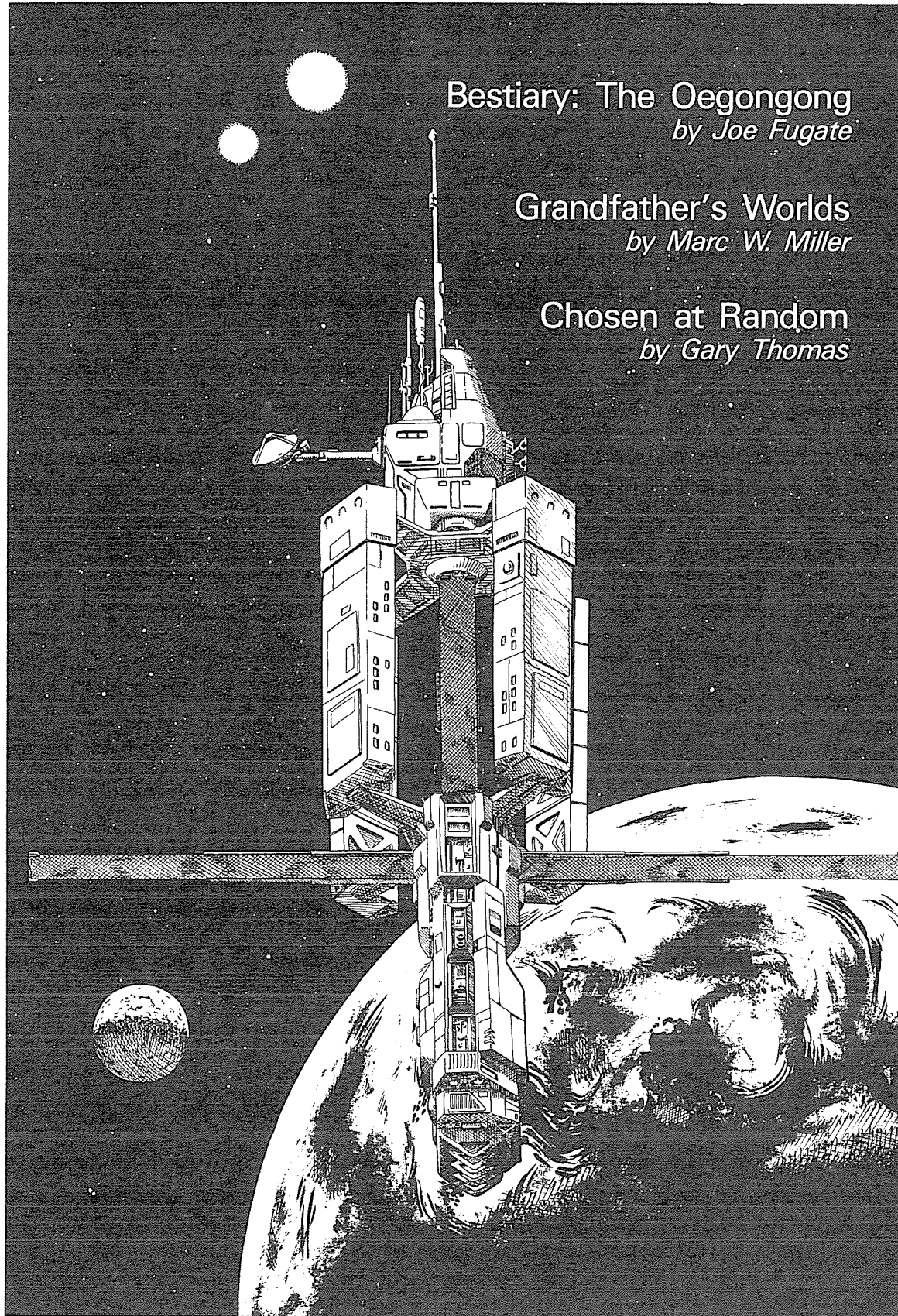

# TWILIGHT: 2000™

## MINIATURES FROM GRENADIER MODELS

**Okay, you grunts! Fall in and listen up!**

Jus' cause a big chunk o' the world's gone kablooney, ain't no reason to let discipline slip! I'm only gonna give these orders once and anybody else that screws up is gonna find my boot in his backside. Got it?

Your mission is: To hit your local hobby shop and get yourself some *Twilight: 2000* miniatures from Grenadier, the best blood-and-guts miniatures this side o' Moskow, all in 20mm/HO scale so's you can use 'em with model trains, tanks, towns, whatever!

Whadda they got? Gluckman, only you would hafta ask that!

Okay, hold onto yer hand grenades and listen up. Pack #401 has five U.S. Infantry for *Twilight: 2000* characters. On the other side of the war are the Soviet Infantry in #402. #403's got Polish Infantry to keep things hoppin' in Warsaw. In a tight spot? Send a courier out to get some Partisans from pack #404.

For the heavy artillers, Grenadier's giving you #405—U.S. Support Weapons and #406—Soviet Support Weapons, both with enough operators to keep the enemy pinned down. Pack #407 has Soviet Cavalry on horseback. It's back to the



good ole U.S.A. for pack #408 — U.S. Assault Squad and #409 U.S. Heavy Weapons. #410 gives the Reds an even chance (lotta good it'll do 'em) with Soviet Heavy Weapons. Polish Paratroops have landed in *Twilight: 2000* Blister #411 and three mounted Polish Lancers hit the trail in #412.

At \$2.50 a pack, you can afford to raise a pretty good-sized fightin' force and besides, when yer runnin' fer yer life in a nuclear winter, it's nice ta have a bunch o' well-armed guys around ya ta keep off the chill o' the grave.

*At your local hobby shop  
or write:*

**GRENADIER MODELS**  
Price and Pine Sts.  
Holmes, PA 19043

*Dealer Inquiries also Invited*

**D-I-I-I-I-S-MISSED!**

**GDW LIBRARY**

*Twilight: 2000* is Game Designers' Workshop's trademark for its role-playing game of survival in a devastated world.

# Chosen at Random: A Vargr Scenario

GDW LIBRARY

"Chosen at Random" is a scenario designed for use by four to ten Vargr player characters, citizens of Dzen Aeng Kho, the Society of Equals in Gvurrdon Sector.

## PLAYER'S INTRODUCTION

"For once, I thought I had it made. There was this new merchant corp., y'see, starting up on Aegadh—well, it wasn't new, exactly; it just had never set up a branch office on Aegadh before. Anyway, they wanted to expand, so they had hired a bunch of us to run a warehouse for them, and they were buying a ship for the Aegadh route.

"It wasn't the greatest work in the world, nor the greatest pay. I mean, all we did was move vacc crates around, mostly, but we thought when the loan came through that we'd all be working on the ship. Some of us had done some starhopping and a few hadn't, but we were all looking forward to it.

"The loan? Oh, yeah, this firm—Gvaeghi Merchant Alliance—they didn't have the cash up front to buy a ship or I guess they would have before. But Aegadh has been trying to boost trade so they've got this new program where they'll put up the down payment and all you have to do is make regular payments.

"So Erzinokh—he ran the company—he was here on Aegadh a lot, filling out paperwork and talking with a lot of guys wearing fancy clothes. And I guess everything checked out because one day we all showed up for work and here was this merchant liner sitting in the bay. What a rush, it wasn't the nicest ship in the world; I mean, it looked like it had already carried its share of cargo, but in a way it was our ship.

"Erzinokh was in a hurry then, so we loaded up the ship and he took off. I guess he had already picked a crew, but to tell you the truth I never saw any of those guys around the warehouse before. He said that Uerangetssae—he was second in charge—would be in the next day to give us new assignments. Well, we didn't see hide nor hair of anybody. And our paychecks were due, too!

"The cargo? I know now, but I didn't

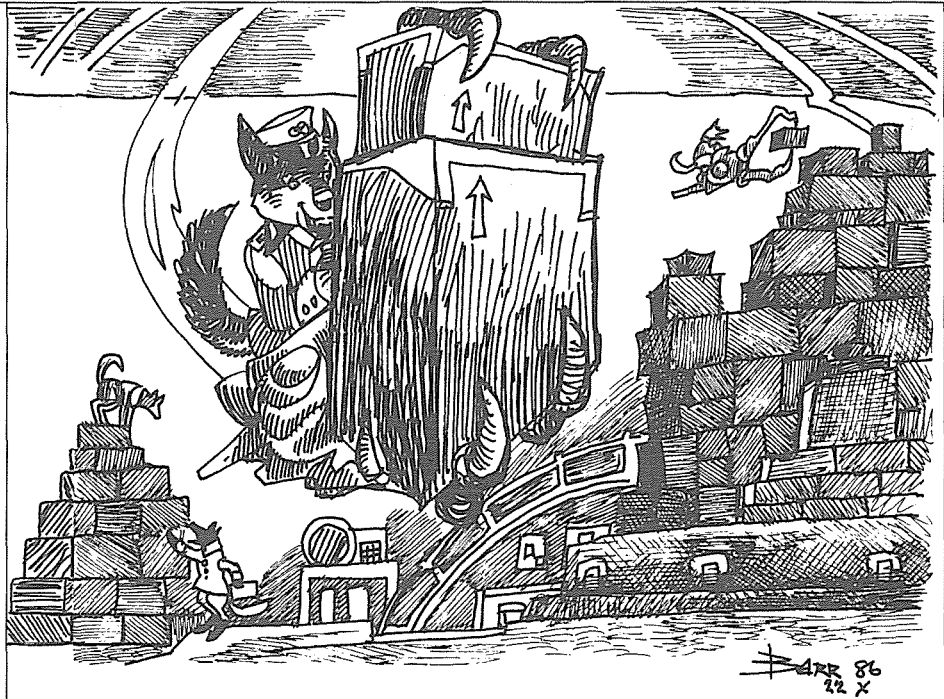

know when we were loading it in the ship. Erzinokh told us it was pharmaceuticals. None of us knew it was highleaf until you guys raided the place and found the crate we missed loading. I don't know how it got left behind. I guess it was just in the wrong place. If we'd known, we all could have retired without any old ship.

"So that's all I know about the thing, except what you guys have told us. We didn't know that there was no such thing as Gvaeghi Merchant Alliance. I mean, we'd been getting regular paychecks until they skipped with the ship. I'll tell you one thing though—I'm going to be a lot more careful who I work for from now on. Nobody makes me a sucker more than once."

—*Transcript of police interview*

The player characters for this adventure are former employees of Gvaeghi Merchant Alliance. Several of them have decided to work together for the time being to locate Erzinokh and the ship. At the least, they might get the money owed them, and besides that, the government of Aegadh has posted a substantial reward for additional information or the ship's return.

The only real clue that the players have is that Erzinokh came from Lloursouth,

a world 4 parsecs away. Erzinokh was familiar with one of the player characters, and told him about some other members of his family who still lived in the backwoods of Lloursouth. The player thinks he could find this area if the group could get to the world. The missing ship itself was scheduled to arrive at Ngoerrgh (1216 E22065A-7), but it never arrived.

Both Aegadh and Lloursouth are part of Dzen Aeng Kho, the Society of Equals, a coalition of more than 50 Vargr worlds in the central area of Gvurrdon Sector.

## REFEREE'S SYNOPSIS

Erzinokh and his colleagues are starting a new company, but it's a company of pirates rather than a company of merchants. To this end, they have travelled around the sector stealing ships by posing as subsidized merchants. The ships have been taken to Gurzueng where they are being outfitted with weapons. Erzinokh's band is skilled at piracy, and they are neither careless nor unprepared, so the party will encounter significant danger in this adventure.

Erzinokh's ancestral home on Lloursouth is now an armed adjunct of the Church of the Chosen Ones; strangers asking questions will not be welcome. A bank on Lloursouth is currently

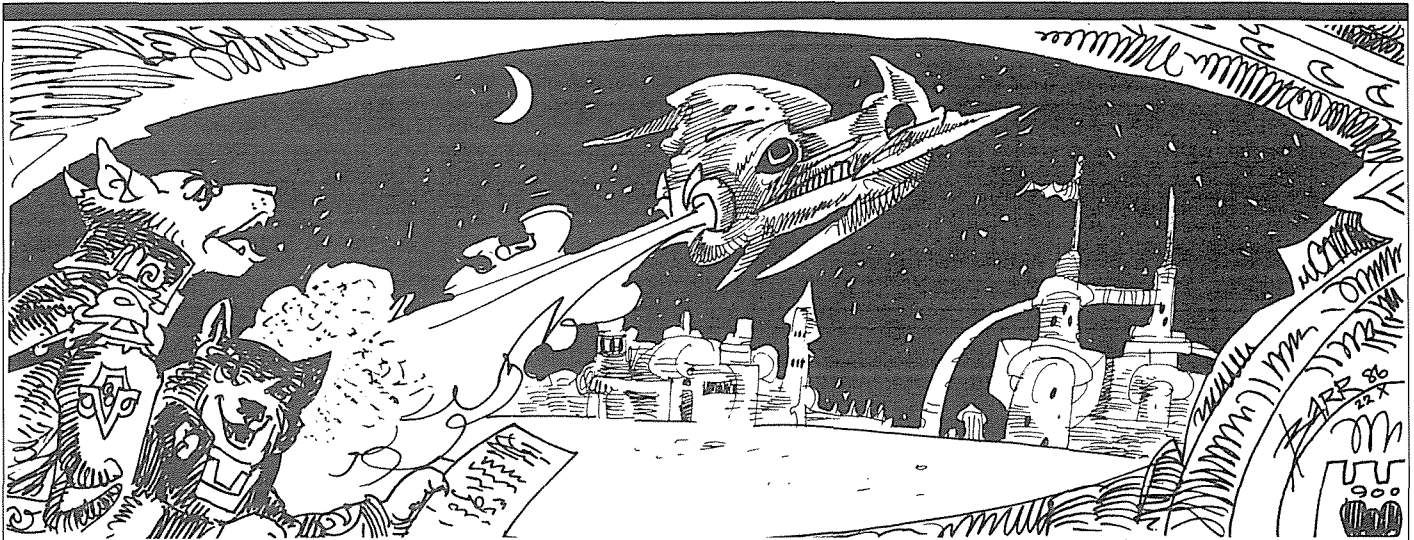

investigating Erzinokh because he pulled a similar scam on his homeworld. Two private investigators had been sent from there to Gurzueng and both died in air/raft accidents.

This adventure follows the "nugget" format used in Alien Realms. Each nugget of information deals with one item of interest for the scenario. The players may discover information in any of several orders, depending upon which path they travel through the adventure. As the referee, you should familiarize yourself with all of the nuggets before play begins.

#### AEGADH

Aegadh (1317 B737AEC-B) is an unusual world in that it is ruled by officials of the Church of the Chosen Ones. The planetary government does not levy any taxes, but it does collect regular tithes from Church faithful and any other residents of the system.

The Church does not tolerate any activities of which it does not approve. Police supervision of the population is almost constant, and infractions are dealt with severely. Fortunately, there are few things which can be said to be "anti-Church," so the population does enjoy a relatively high freedom, notwithstanding the continual intrusion of police into private affairs.

An investigation into the details of Erzinokh's plot will show that he is indeed skilled in forgery. Company documents were good enough to fool the Aegadh lending institutions that put up the subsidy money. When they requested more information about his company from its home world, Kfolael (1421 B86AAA6-B), they received a reply showing an excellent credit history. Authorities now know that the intersystem mail was tampered with for Gvaeghi Merchant Alliance never existed.

#### NGOERRGH

The trail to Ngoerrgh (1216 E22065A-7) is a false one, and this backwater world has little to recommend it. Its government uses computers to make important decisions. If the government had better technology, the citizens would be a lot happier and the standard of living would be a lot higher.

#### THE MISSING SHIP

Erzinokh's crew included an electronics expert who busily spent the time in jump disabling the stolen ship's transponder. Thus, its signal is different, and authorities in systems through which it travels will not have a record of its passage. The new

signal, however, does leave its own trail, and if the party is clever they may be able to follow it. At each starport they can receive a list of ships in system at the appropriate time, and by cross-matching these lists they could discover the new transponder signal of the ship they are seeking. Starport authorities at worlds with higher law levels will not release this information readily.

#### THE HIGHLEAF TRAIL

One way that the characters can check their route is by asking around at each stop as to the availability of highleaf.

Erzinokh's route took him through 1417, 1616, 1717, and 1816, to 2015. Characters can discover that at each stop there was a sudden influx of the potent drug, but that the supply quickly dried up, showing that a permanent source had not been established. The time periods of these supplies will correspond to the times of Erzinokh's flights with the stolen ship. Erzinokh was careful not to sell his entire cargo at any one world, so as to keep demand (and the price) high.

Characters might want to remember that highleaf is restricted on most worlds. Their inquiries must be carefully made or the party is apt to find itself in trouble with the law. One solution to this problem, in fact, would be for them to approach local authorities directly, explaining their situation and why they want to know about recent drug levels.

Although highleaf has little effect on K'kree, its abuse by humans can be both exciting and devastating. The drug's initial thrills can yield a bitter harvest of addiction or permanent health impairment. Both the intoxicating effects of the drug and its dangers to health are applicable to Vargr as well as to humans.

#### LLING

Lling (1417 B261866-9) is a rich world controlled from Aegadh. The influence of the Church of the Chosen Ones is small here and the inhabitants of Lling show surprisingly little unrest, for Vargr rules from afar. Lling is not a large planet, but even so, its population density is one-tenth that of Aegadh.

Within the Society of Equals, Lling is renowned for its fine art. The skill of its engravers is particularly well-known for they have succeeded in blending laser technology with art to produce beautiful miniature designs. The motifs created by these craftsmen are popular with Vargr everywhere.

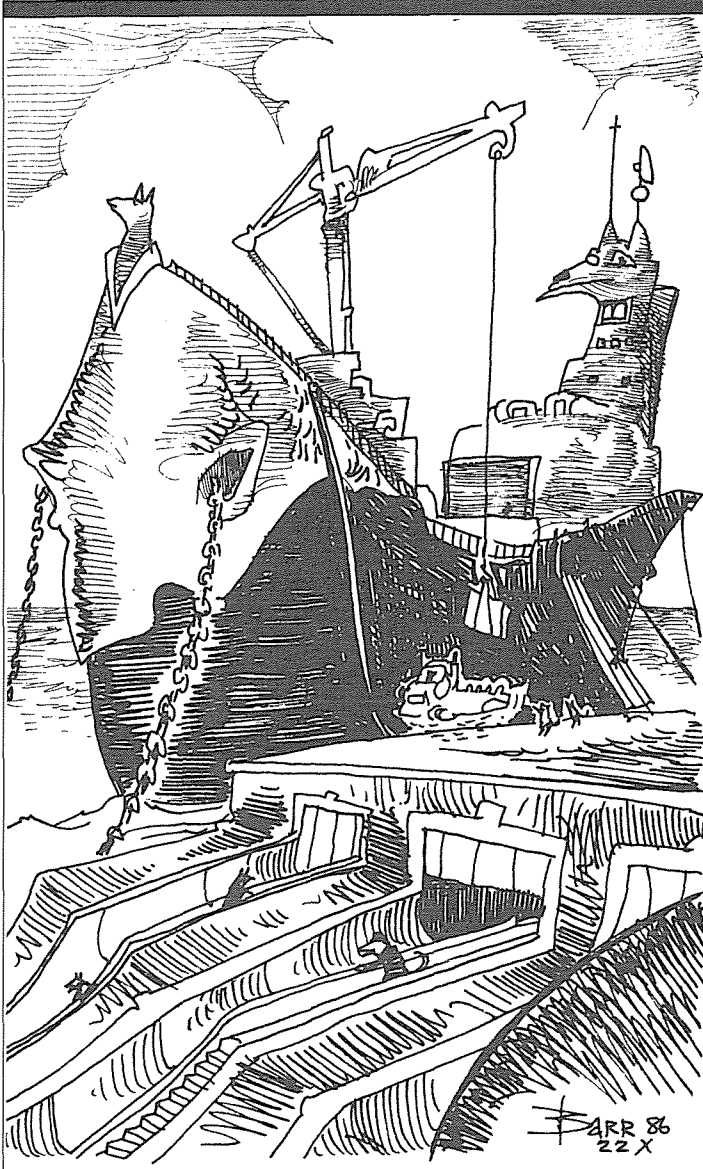

### GAKNOU VAL

The Gaknou Val system (1616 A98A614-2) is home to a Society of Equals naval base, reflecting its positional importance between the high population worlds of Aegadh and Lloursouth. The prevention of illicit piracy is paramount to the government of the Society of Equals, and this base plays an important role in that mission.

Licit piracy, on the other hand, is carried on along the borders of the Society against worlds not aligned with it. The Society Navy takes no action whatsoever against such plundering, and, in fact, supplements its own revenues by occasionally engaging in it.

Gaknou Val itself is owned by a Vargr corporation active throughout Gvurrdon Sector. The corporation exports fish and minerals from this watery planet. No fixed bases have been installed on the world, and all personnel and equipment are imported on a regular basis.

### LLOURSOUTH

Lloursouth (1717 A253A9E-C) is one of the few places that has more government interference than Aegadh. Characters will

encounter police everywhere. Not only will the characters rarely be out of sight of a police officer, but they will be stopped and questioned by police at least twice a day. If their papers are not in order a trip to the station can entail considerable delay while problems are ironed out.

If the characters ask any official source about Erzinokh, they will be given the runaround. Lloursouth's bureaucratic government is not designed to be efficient, and most agencies will readily refer the party to another agency which is "actually in charge of such matters."

But persistence will pay off. The party can eventually discover that Erzinokh is wanted on Lloursouth for theft of a starship. It seems that five months ago he posed as the leader of the Gnaeraeks Merchant Alliance; same song, different tune. Once the government subsidy came through, he and the company officers disappeared with the merchant ship and all company documents.

Police on Lloursouth will not cooperate with the players much concerning this second disappearance. After all, the ship is now long gone so it is hardly a local matter any more. The police have enough on their hands with the constant surveillance of the population without having to worry about stolen ships that might be trillions of kilometers away by now. They can, however, refer the characters to the mortgage holder for more information.

Rroelokdzoks Assurance, a Vargr bank, is understandably upset at the ship's disappearance. Their investigation of the matter has been turned over to Igz Investigators, but Rroelokdzoks will give the player characters the same information in hope that two search parties will have twice the luck of one.

## GDW LIBRARY

### ERZINOKH'S FAMILY

Erzinokh's fond reminiscences of his family "back on Lloursouth" are romanticized to an extreme. The actuality of the current situation bears little resemblance to the nostalgic tales of his youth.

His family lives on a religious commune owned and operated by the Church of the Chosen Ones. Gracing the grounds are a large temple and the famous "Museum of the Supremacy of Vargr Culture." The museum contains a variety of exhibits showing the history of the Vargr race and the Church. The museum purports to be an independent entity, but the relationship between it and the Church is very close indeed.

Visitors can learn how the Ancients carefully chose the original carnivore stock on Terra, and then how they manipulated these beasts into the perfect beings that the Vargr are today. Dioramas depict many of the important events in Church history, particularly the meeting 200 years ago between the founder of the Church and a living Ancient when the founder received the Church's oracle artifact. Another diorama shows how the galaxy will be governed when the Vargr have succeeded in conquering all of the surrounding inhabited regions.

The members of the commune on Lloursouth dress entirely in white, trim the fur around their ears, and have a variety of other eccentric beliefs and practices (remember that the Church of the Chosen Ones is not consistent among its 19 branches). They don't mind visitors who are interested in seeing the museum or working for the commune, but strangers

who ask pesky questions are not appreciated.

Erzinokh himself has not been to see his family for more than twenty years, when he had a falling out with the Church leaders there. He vowed that he would from then on be independent from the Church and all of its activities, and that he would never visit his homeworld again. He has passed through the starport a number of times since, but he has remained true to his pledge and has not travelled to the commune site.

Erzinokh would not be welcome at any rate, and Church members who knew him 20 years ago will not take kindly to requests about his whereabouts.

The commune has a secret cache of small arms which they will use against the characters if they feel threatened. They have managed to keep the guns despite the high law level of the world, by bribery, stealth, and the cooperation of pro-Church officials in the local constabulary.

### OEGONGONG

In their travels on Lloursouth, the characters are liable to encounter a local pest, the oegongong. (More information on this creature can be found in this issue's Bestiary.)

The adult oegongong is a distinct threat to air/raft travel. Chances for a collision are increased because of the air/raft's speed and the small size of the oegongong. Such a collision will ignite the oegongong's hydrogen sacs causing an explosion that can damage an air/raft. If the party is careless or flies on automatic pilot, a collision is inevitable. The odds for a collision will also come into play if the characters are involved in a high-speed chase.

### IGZ INVESTIGATORS

Officials at Igz Investigators will be suspicious at first if the party asks about the case because they have just received unfortunate news about the investigator assigned to it. The company was notified that the investigator was killed in a hit-and-run air/raft accident after following a weak trail to Gurzueng. Another investigator left for Gurzueng yesterday to follow up on the matter. Igz does not have any other information about the case, nor will they give out the names of the investigators involved.

### UZOTSSAZA

Uzotssaza (1816 B225435-D) is more technologically advanced than most worlds in Dzen Aeng Kho. In fact, although several worlds have the same tech level, only two worlds are higher in technology than Uzotssaza.

Uzotssaza's 12,000 inhabitants live in a small complex orbiting the world. The planet's atmosphere is both thin and tainted, so life in a controlled space environment is simpler than life on the surface would be.

The entire complex is fully automated, a condition that has reduced the general health of the Vargr who live there. Conditions are so pleasant that the Uzotssazans have developed a philosophy of lazy hedonism: if it feels good, do it, but don't do it too much.

The permanent residents have gone to flab, and any physical exertion is frowned upon as ostentatious. The settings for the station's artificial gravity have been turned lower and lower over the years, so that now the residents live in entirely weightless conditions. This further impairs their muscular

strength.

Today, even in the weightless environment, most residents wear zero-G maneuver equipment in personal harnesses. These devices are not meant to simplify travel around the station so much as they are meant to further reduce any strenuous activity.

### GURZUENG

Gurzueng (2018 B788300-B) is a sparsely settled world with no local industry. Its two cities hold most of the world's population of 800 Vargr split evenly between them. One city, Ekx, is located next to the starport, and the other, Dzi, is on the continent on the other side of the world. Gurzueng has no government, which suits the inhabitants just fine.

A handful of the Vargr on Gurzueng run the class B starport, servicing ships passing through, but most of the residents are silver miners. Many of the richest veins lie just beneath the planet's thin topsoil, but strong winds blowing constantly across the landscape make mining a formidable task. The ore is extracted by the Vargr themselves without the use of mining robots.

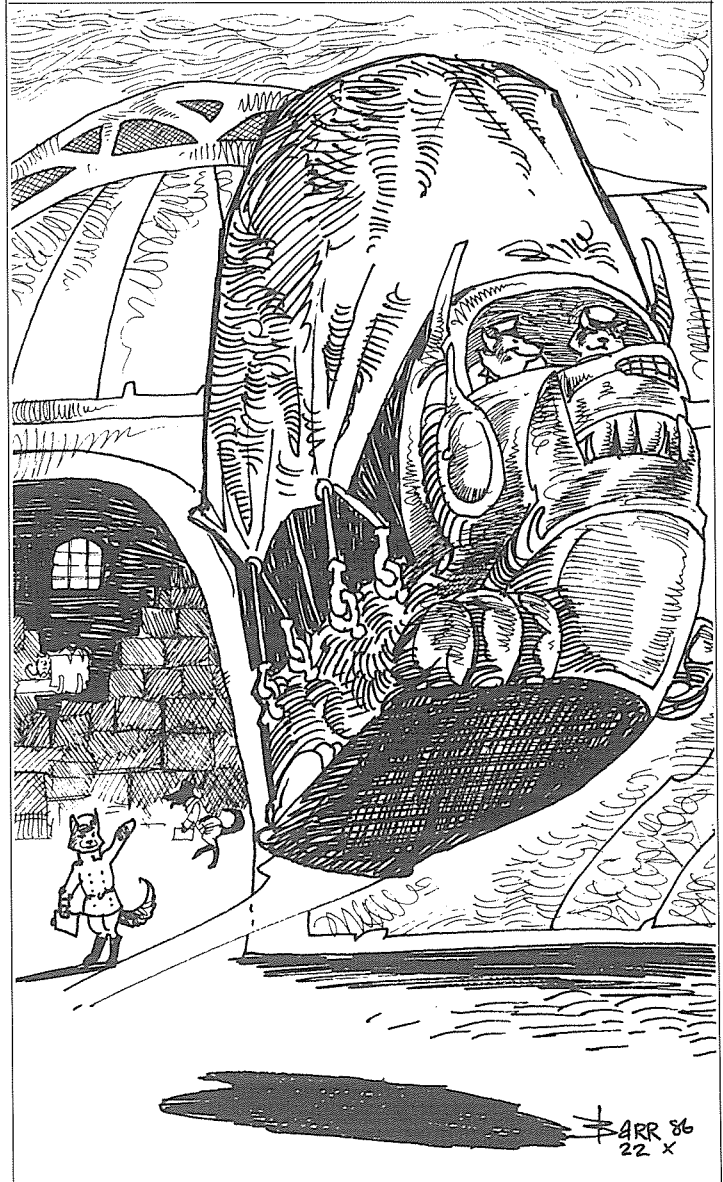



Streetwise skill can pay off on Gurzeung. An on-the-ball character will easily discover that a great new shipment of highleaf recently arrived on the planet.

#### THE IGZ AGENT

Asking around will yield the information that the second Igz Investigators agent was killed a few days before when he was accidentally hit by a low-flying air/raft. By now the players should be extremely suspicious of these coincidences.

His room rent was paid through the end of the following week, but with his untimely death the landlord has removed his belongings and prepared to send them back to Igz on Llor-south. This is getting to be a usual state of affairs with the landlord as he sent the first agent's belongings back some time ago.

If questioned, the landlord will have little sympathy for either agent. "They should have been more careful where they were walking," he says.

Both agents were struck down by air/rafts which did not stop after the accidents. No other evidence has been found, and there is no government on Gurzeung to put forth an investigation or to file charges against any culprit.

Given the proper inducement (such as a Cr20 bribe), the landlord will divulge some of the activities of the agent before his death. In particular, he made three visiphone calls to someone on the continent around the globe. The numbers were recorded by the landlord in order to bill the agent for them later. The landlord will also be willing to give the agent's belongings to the party, for a suitable fee.

#### GURZUENG DOWN

The starport on Gurzeung is busier than one would expect at a world with such a low population. When the characters arrive, they might notice a ship in port unloading a number of crates marked with the name "Dzofakael."

Dzofakael is a manufacturer in the Vargr Extents, well-known for its sturdy heavy equipment and ship armaments. Among its products are bulldozers, backhoes, tractors, and small fusion-powered locomotives, any one of which might be used in a typical mining operation. Their other products include heavy lasers, PGMP-13s, sand casters, and ship hull armor, none of which would be used in a typical mining operation.

It is impossible to see what is in these crates without open-

ing them up. The crates are being loaded onto a grav truck.

#### FOLLOW THAT GRAV TRUCK

GDW LIBRARY

Once loaded, the grav truck starts up and flies away. Several Vargr grav platforms are sitting unattended on the dock; if the characters look they will find that the keys have been left in one of them. If the party takes advantage of this opportunity they will be able to follow the grav truck to a warehouse on the ocean shipping docks of Ekh.

At the warehouse the Dzofakael crates are combined with others already there and loaded onto an ocean freighter. The characters will recognize the names on the other crates as being manufacturers of space ship components, mostly military. The freighter is scheduled to leave for Dzi the next morning.

The freighter is guarded by three large Vargr armed with SMGs. Inside the warehouse are two more Vargr with automatic shotguns. Transshipment invoices on the freighter and inside the warehouse show that the crates are to be ultimately delivered (by grav truck) to an area deep within the other continent.

#### TRAVEL OPTIONS

A number of modes of transportation are available to the party should they wish to pursue the equipment on the freighter. The most obvious ways to follow along are to buy passage on the freighter or to stow away below decks. Passage to Dzi will cost Cr425 each with meals included for the six day trip. The food is the same as that served to the sailors from the ship's galley, filling and spicy.

A passenger hovercraft makes a regular run between Ekh and Dzi. Passage costs Cr750 each, but the hovercraft is faster and will arrive in Dzi two days before the freighter.

If the characters are not yet ready to trust themselves to the locals, they can rent grav platforms for Cr400 per day. Each grav platform can hold a crew of two. The characters can install a heavy machinegun on any grav platform they rent. The trip to Dzi takes 40 hours; dawdling along the way is ill-advised as the platform has enough fuel for only a little more than 50 hours. The platforms can be refueled at Dzi for Cr40 apiece.

If the party was successful in breaking into the ship or the warehouse, they might know the cargo's final destination and they may decide to go there. On maps of Gurzeung the area is shown as a wilderness with no inhabitants or outposts.

### THE VISIPHONE NUMBER

The second Igz investigator made three calls to Dzi before he was killed. All three calls were made to a wilderness guide. The investigator was planning to hire a vehicle for a safari inland, but he did not tell the guide the precise location of his trek. The guide wondered why the investigator never called back after arrangements had been made, but he did not follow up on the matter.

If the party bribed the landlord enough, they will find a round-trip hovercraft ticket between Ekh and Dzi among the investigator's belongings. The investigator died before the trip could be made. Also among his things is a map of the other continent with four areas marked with small Xs. One of these locations is in fact the destination of the ship armaments. The other three are just wilderness.

### THE PIRATE BASE

The wilderness hides a base of operations for Erzinokh's corsair band. Four merchant ships are being converted to military use, including the two the characters have been tracking. The ship Erzinokh stole from Aegadh is operational and fully fueled, but the other three ships are only partially converted.

Parked alongside the merchant ships, but covered over with tarpaulins, are three Rampart IV FF-77 fighters. These Imperial vessels were stolen in the Spinward Marches. The fighters were shipped in sections to be assembled near their point of deployment. Erzinokh hijacked the shipment and replaced the crates holding the fighters with similar crates holding ordinary industrial equipment.

After the transporting of the fighters here, ship mechanics have been kept busy putting the pieces together. One Rampart is fully operational, fueled and armed. Another could be made battle ready in four hours. The third is still weeks away from its maiden flight.

The perimeter of the pirate base is heavily guarded, but if your players have made it this far without serious mishap it would be unfortunate to kill them off without a chance. Adjust the pirates' defenses according to the capabilities of the party. The finale to the adventure should be fair to both sides of the struggle.

Depending on the type of characters used in this adventure, you might play out a ground action or a ship-to-ship combat in the Gurzueng system. Several scenarios are equally enjoyable, depending on the temperament of your players.

### THE RINGLEADER'S MEN

Erzinokh's crew are hand-picked (paw-picked?). If the party is at all careless in their investigations they will pick up a tail in Ekh or Dzi. Because of their number and their semi-official status they are less likely to suffer the sudden effects of an air/raft accident.

The pirates may try to kidnap the characters if an opportunity arises.

### THE RINGLEADER

Erzinokh is feared and admired by his crew. At 38 years of age, he is a corsair leader with Leader-4 skill and a charisma of B. He leads by personal example; his bravery and strength are an inspiration to those around him.

**“He leads by personal example  
...an inspiration to those  
around him.”**

If the party has been captured rather than killed, and if they have not caused him excessive inconvenience, he will be impressed by the fact that his old employees could find him across such a distance of space. Because of this, he will offer them positions within his band of corsairs if the characters desire.

The characters will have little choice in this matter: they know too much to be let free. If they do not accept Erzinokh's offer, he will have them killed. Seen in this light, and considering his personal magnetism, the characters may be inclined to join forces with Erzinokh's group.

—Gary L. Thomas

*continued from page 8*

Causeway. Together with Alazan Bay, it runs nearly 40 km inland to within 20 km of Kingsville.

There are a number of small craft—motor launches, pleasure craft, fishing and shrimping boats—anchored inside Baffin Bay. All belong to the marauder warlord Colonel Rodriguez. If the characters enter Baffin Bay, they will be intercepted by patrol boats armed with machineguns and grenade launchers and boarded. The characters will then be disarmed and taken to see Rodriguez. The adventure will then proceed from the description of Kingsville given in *Red Star/Lone Star* (page 34).

It is also possible that the characters, having reached Kingsville by land, will choose to escape the area by boarding and stealing an untended motor launch. In this case, the water borne portion of the adventure will begin in Baffin Bay with the characters shooting their way out of the harbor and escaping into the Laguna Madre.

### PORT MANSFIELD

Once an important port, Port Mansfield was before the war a tiny fishing and resort village with a population of only 125. The village was abandoned when the Mexican armies swept north and is a ghost town now. The harbor marine facilities are still in relatively good shape, and hunting and fishing in the area are ESY:RCN and ESY:FSH tasks.

### BRAZOS SANTIAGO PASS

Brazos Santiago Pass lies between the southern tip of South Padre Island and Brazos Island. On the Padre Island side is an old Coast Guard Station and lighthouse. Both are manned by marauders, and there are armed fishing boats and launches anchored at Port Isabel on the mainland side of the Laguna Madre.

Characters who reach Brazos Santiago by boat will be intercepted by the marauder boats and forces in the area, disarmed, and taken to *El Jefe* in Brownsville. The defenses in the region are described in *Red Star/Lone Star* (pages 39-40).

—William H. Keith, Jr.



# Fighter Profile: The Rampart IV and V

## FF-77 RAMPART IV

*Origin:* IDS Corp., a division of Sternmetal Horizons. *Type:* Fighter/interceptor, interplanetary, all atmospheres. *Engine:* IDS Mk.68H-1 Fusion Chamber. *Dimensions:* l=8.10m, w=4.27m, h=2.66m. *Weights:* Max. loaded=20.0 tons, dry=14.8 tons. *Performance:* Max. acc.=6g, agility=6. *Armament:* two Jannen Mk.5TR Fusion Cannons. *History:* First flight on 1107-364, service IOC on 1109-130. *User:* Imperial Navy.

The Rampart IV project, secret until recently, was given a high priority due to the Zhodani invasion of the Spinward Marches in 1105. After many years of slow development and near cancellation, work was finally accelerated and the Imperial Navy awarded a development and production contract to IDS Corp. (Imperial Dynamic Systems Corp., of Ansendorn/Core) in 1106. In 1107 the first prototype began flight testing at a secret test location. IOC (Initial Operational Capability) was achieved in 1109 when the FF-77 Rampart IV deployed to the Spinward Marches. Further details of the fighter's combat career are classified, but rumor has it that it is a "pilot's ship" and highly effective.

Much of this effectiveness may be due to its Naasirka LP-65N-7/R computer. Reportedly, the ship's performance has given it considerable popularity among pilots.

Rampart IV is also fitted with a 0.4 ton, type M-4/WQ24 ESU (Ejection and Survival Unit). The ESU has a rocket ejection unit, extra fuel for short duration travel (2g max) or surface landing, emergency life support, a rescue beacon (variable frequency), and a 50kg survival kit which includes food, a combo filter/resp mask, an instant shelter, and a weapon.

## FF-81 RAMPART V

*Origin:* LSP Military Technologies Group. *Type:* Ship killer, surface attack, interplanetary, all atmospheres. *Engine:* IDS Mk.68K-7 Fusion Chamber. *Dimensions:* l=9.33m, w=5.65m, h=2.34m. *Weights:* Max. loaded=20.0 tons, dry=15.2 tons. *Performance:* Max. acc.=6g, agility=6. *Armament:* Two Amborg/Daniksen PS-33 Mk.1 six-place missile launchers, each carrying twelve missiles. *History:* First flight on 1108-042, service IOC on 1109-252. *User:* Imperial Navy.

A brother project to the Rampart IV, the Rampart V contract was awarded by the Imperial Navy to LSP/MTG Div. in 1106. Its engines are a modified version of the Rampart IV's and it uses two of the M-4/WQ24 ESU's for a pilot and a weapon's operator (gunner). Its computer is the larger Naasirka LP-66N-3/3 which uses various weapons delivery programs.

A unique feature of the Rampart V system is the ability to allow up to five ships (usually four) to combine their missile launches into one salvo which is equivalent to a missile factor seven.

One of the four craft is designated as the leader and enters the appropriate program into his computer (1 space, 2MCr) while the other four fighters load a corresponding gunnery program (1 space, .5MCr). The four computers update each other via short range microwave communications run automatically.

If the leader's ship loses its computer capability, then each

of the ships must fire its weapons independently. Maximum size of the formation of four (microwave comms range) is 5000km.

## REFEREE'S INFORMATION:

Firing individually, each Rampart V adds its gunner's DM to the DMs from 'Predict' programs, if used. This procedure results in a net DM for each fighter. For the factor seven (to hit and damage) salvo shot these net DMs are averaged over all four ships to produce a DM for the salvo.

Also: The Rampart V's two hardpoints (see illustration) support the equivalent of a triple turret in weaponry. The missile launchers may be replaced with droppable ordnance, ECM pods (self-powered, act as ECM computer program), intelligence gathering equipment, or two 1.5 ton cargo/fuel pods. Refs, use your imagination.

## RAMPART IV

*High Guard Statistics:*

FF-0106SR1-10000-05000-0

2

2

TL=15, 20 tons, Fuel=5.2 tons, Agility=6, Cost=MCr27.85 (dry).

## RAMPART V

*High Guard Statistics:*

FM-0106MS1-K0000-00004-0

TL=15, 20 tons, Fuel=4.2 tons, Agility=6, Cost=MCr33.2 (dry) Carries twelve (12) missiles; 4 per launcher.

*Weight of Ejection/Survival Unit (ESU) = 0.4 tons ea.*

—Robert Liebman

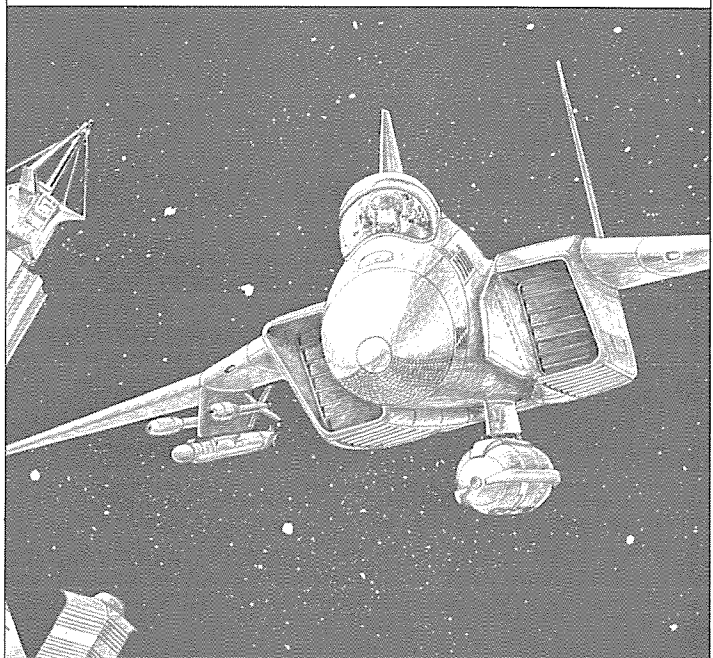

# RAMPART IV FIGHTER/BOMBER

GDW LIBRARY

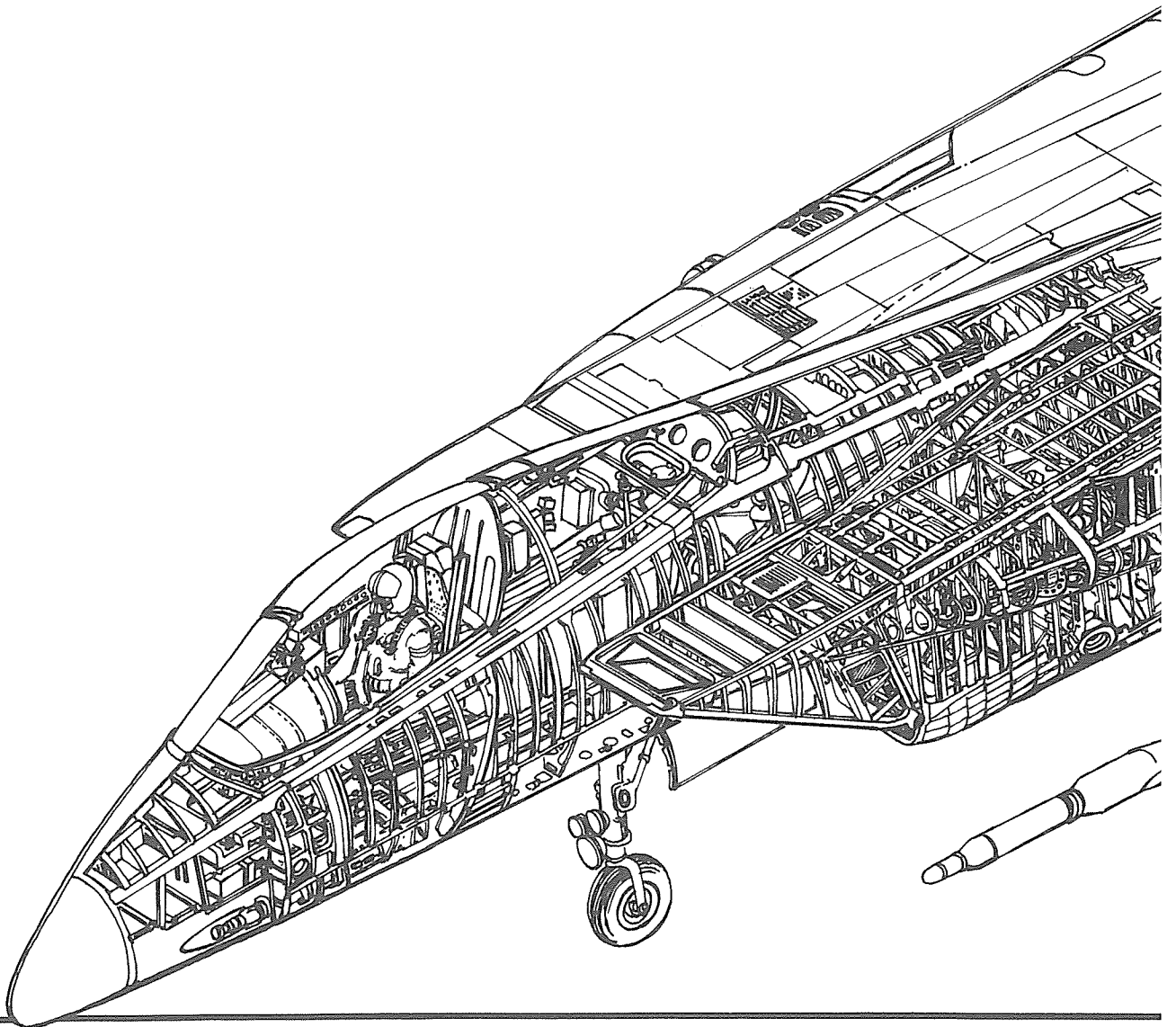

GDW LIBRARY

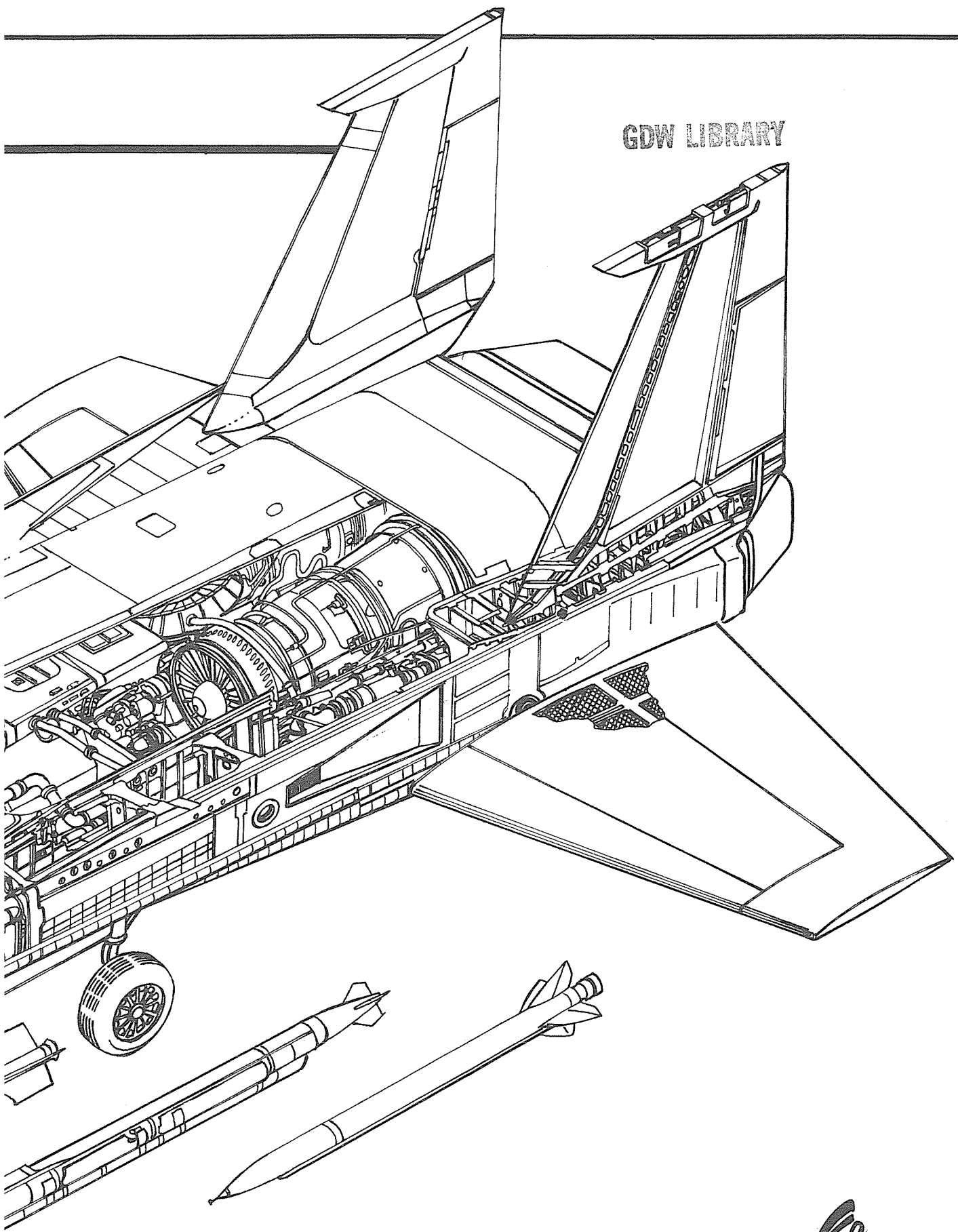

# Church of the Chosen Ones

The Church of the Chosen Ones is a fanatical Vargr sect which believes that the Ancients not only "invented" the Vargr race by genetic manipulation of Terran carnivores, but that the Ancients also returned to the Vargr several times, improving the race to the point that it could take its rightful place as the leader of this part of the galaxy. Some Church members even believe that the Ancients will return again to bring this about. The Church's influence has waned since its founding 200 years ago, but it still has followers on many worlds.

In the Vargr language of Gvegh, the Church of the Chosen Ones is known as Ourrghfaengaeknokskuvorrg.

The leader of the Church has the formal title of "Llaetsdhithae," and each official in the next lower level of the Church hierarchy is known as a "Dhaer," or "listener."

The Church of the Chosen ones is a church only in so far as it asks for a strong degree of devotion and trust from its members. It does not worship the Ancients any more than it worships the Vargr race. It does believe that it is the true leader and the only hope for the Vargr race because Church members are the only ones who recognize the true position of the race in the destiny of the galaxy.

The "holy book" of the Church of the Chosen Ones is an Ancient artifact. This artifact is a twisted piece of multi-colored crystal, garish in its appearance, but pleasing enough to the Vargr taste. The founder of the Church claimed to have received this artifact personally from the Ancients. Only the inner council of the Church has access to the device and, in fact, no other members of the Church have ever seen it. At various times the device is functional and it then reveals some new insight to the sect. It is not available for public examination, of course, because it is holy to the Church. Among non-believers there is a great deal of skepticism about this process.

How the device works has never been discovered. Some believers speculate that it is in fact a two-way communication device which allows Church leaders to contact the Ancients in their present home. This belief is furthered by the fact that pronouncements from the device typically occur during crises in Church history.

Each pronouncement of the artifact is numbered and the collection of these pronouncements forms the holy book of the Church. Some of the pronouncements are seemingly without meaning, being composed only of a series of numbers or asym-



metric designs. These are held in special awe by believers, some of whom speculate that the patriarchs of the Church know the meaning of these oracles.

The artifact glows faintly when a message is waiting, and when a message is actually being received it glows so brightly that bystanders can be blinded if they look directly at it. The Llaetsdhithae leader wears the artifact on a gold chain hanging around his neck. To receive a message, he places the device on his head so that one end covers his left ear and the other end covers his right eye. He then hears the words of the new message through one ear

while he sees an apparently random pattern with the opposite eye.

The leader is assisted in his duties by nineteen "listeners," so called because they listen to and obey the messages of the artifact as the Llaetsdhithae reveals them. Each listener is assigned to an administrative area ranging in size from a small city to a number of sectors or subsectors. The listener assigned to an area is responsible for Church affairs in that area, such as building, publishing, recruiting members, and appointing officials of the Church in his region. About one-half of the time, the Llaetsdhithae has been chosen from among the listeners. As the Church grows, the number and areas of the administrative units changes.

The first message received from the artifact was "Treat me well. I am the third most valuable thing." This message has been repeated before every subsequent message. The meaning of this message is interpreted by the Church as follows: the artifact, since it serves as a two-way communication device with the Ancients, is the third most valuable thing in this area of the galaxy. The Vargr race, because of its favored position among all of the sentient races, is the second most valuable thing. The most valuable thing has not been revealed, and its identity is a matter of speculation among the Church faithful.

Some say the most important thing is the Ancient race itself. Others say it is the Church of the Chosen Ones. Still others say the most important thing is something that does not exist yet that will be revealed at some future time.

The first portion of the message, "treat me well," is taken very seriously by those in the Church assigned to care for the artifact. Before the full importance of the artifact was understood by the Church, many mysterious deaths resulted

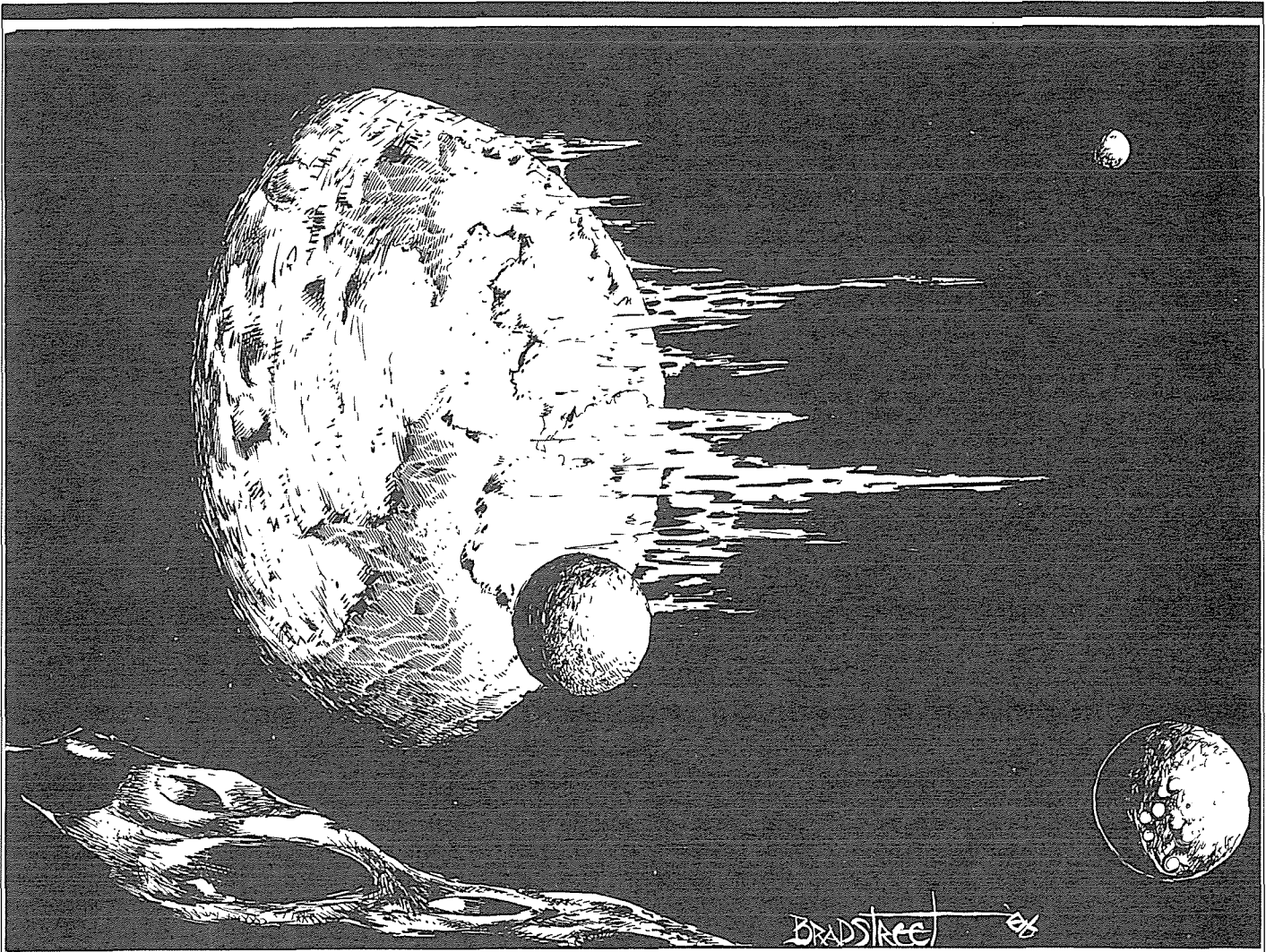

from carelessness with it. These deaths have encouraged the view that the artifact is a two-way device.

Is the artifact genuine? The Church believes it is, and so do many Vargr who are not associated with the Church. As the artifact is considered holy by the Church, it has not been exposed to careful, unbiased examination by the scientific community, so there is plenty of room for opposing opinions concerning the artifact's origins. Some scientists do believe the device is an Ancient artifact, but opinion is divided over what it actually is.

Naturally, the Church is organized charismatically. The Llaetsdhithae is a charismatic Vargr who demands and receives total loyalty from the Church faithful. This leader is chosen by the artifact, usually after the death of the previous leader, although in a few instances the leader has been chosen before the death of the leader in power. As the leader chosen by the artifact always has a high charisma, the Vargr accept him without difficulty. There has never been a female leader of the Church. This is not an established policy; it is just that the artifact has never chosen a female for the post. In two instances the leader chosen was only a pup. One of these lived as leader of the Church for 62 more years, the longest anyone ever held the post. The other died soon after the announcement.

Directing the Church is a difficult task because the tendency of the Vargr is not to obey a leader at any great distance

away. The "listeners" must, in response to this, do a good deal of travelling throughout their administrative areas. The leader of the Church avoids travel by virtue of his control over the artifact.

*Referee:* Is the artifact genuine? Does the Vargr race deserve a special status in the galaxy? Will the Ancients return to establish the Vargr in their proper position of leadership? Answers to these questions are not available to player characters, but we will deal with them briefly here.

The oracle device of the Church of the Chosen Ones is an Ancient artifact, but its function is not properly understood by the Church. The Ancients developed the Vargr from Teran carnivore stock, not in an attempt to produce a superior race, but in an attempt to create a species of servant.

To help further the development of intelligence in the neo-Vargr race, the Ancients used three different psionic devices. One of these was discovered by the founder of the Church of the Chosen Ones.

When a Vargr places this device properly on his head, the device psionically reads the Vargr's thoughts. The device then articulates sounds to clarify the Vargr's thinking. The seemingly random patterns seen in the device are meant to stimulate the opposite hemisphere of the brain, enhancing the learning through the ear.

Because the device does have artificial intelligence, and

because it is meant to help the Vargr develop greater intellectual and socialization skills, its messages seem to support the ongoing activities of the Church. Sometimes this is coincidence. Other times the device is actually using the Church structure (which it understands from the thoughts of the Llaetsdhithae) to stimulate the development of Vargr society and culture.

About thirty years ago, the Church discovered a mirror-image of the artifact. This is the second device that the Ancients used in training the young Vargr race. By sending messages to one eye, while cross-stimulating the brain with another message to the ear, this device developed Vargr intelligence in other ways. Because the "messages" (through the ear) from this device seem to be random, the Church is at a loss to explain the device's function, and has not announced its discovery. This device, incidentally, is the "second most valuable thing."

When a Vargr had been under the influence of these two

When a Vargr had been under the influence of these two devices for a certain period of time, a third device would be used to test the success of the training. This "most valuable thing" would decide whether a Vargr's genetics were sufficient to allow him continued membership in Vargr society. Vargr who failed this test were disposed of by the Ancients. Perhaps fortunately for the Church, this device has not been discovered.

The argument for Vargr racial superiority used by the Church is specious. If the motives of the Ancients were to create a new, better race, then they might have had the technical prowess to accomplish this. But the Ancients' goal in developing the Vargr was to create a race of perfect servants, and in this the Ancients failed. The experiment was abandoned sometime before the Final War.

—Gary L. Thomas

This article originally appeared in *The Travellers' Digest*, Issue 3, © 1985 Digest Group Publications.

GDW LIBRARY

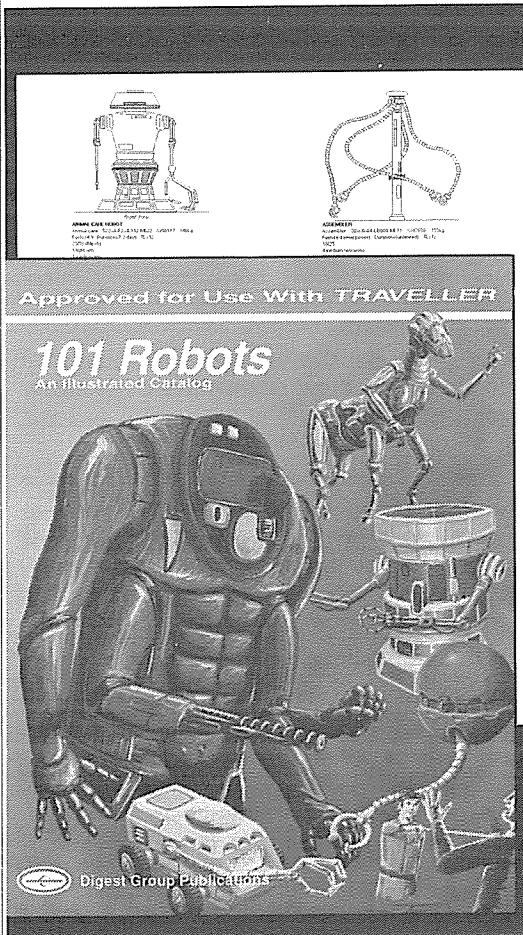

## New! From the Authors of *Book 8: Robots*

# 101 Robots: An Illustrated Catalog

Here, under one cover, are 101 robot designs, each complete with URP profile, a written description, and an illustration. If you've ever wanted to use robots in **Traveller**, this book is what you've been waiting for!

This 48-page 8-1/2" x 11" book has all the details you need right at your fingertips. Robots of all shapes and sizes, for every conceivable purpose, from all the major races. Get your copy today!

**\$7.00**

Available at your **Traveller** dealer now!

Or Send Check or Money Order to: Digest Group Publications, 8979 Mandan Ct., Boise, ID 83709. Please include \$1 per order for postage and handling; Idaho residents include 5% sales tax.

(Overseas Orders: Send International Money Order or Cashier's Check in U.S. Funds for \$7 plus \$2.50 Postage and Handling)  
VISA and MasterCard Accepted – Phone (208) 362-3094.

Also available: **Grand Survey**, Exploring and Detailing Worlds – \$7.00

**The Travellers' Digest** magazine – Subscription (4 issues) \$14.00  
Overseas subscription \$22.00

# Vargr Grav Platforms

## SHIP'S LOCKER

It is impossible to characterize anything as being "typically Vargr" since they are such a diverse and fragmented race. This goes as much for equipment and gear of all kinds as it does for governments or societies. Most of what we call "Vargr" is based on the standards of the various Gvegh-speaking cultures of the regions to Coreward of the Spinward Marches. This still leaves quite a bit of ground to cover, but serves frequently as a basis for discussing "typical Vargr" items or attitudes.

Many Gvegh groups, and particularly a number of corsair bands, make use of a highly specialized vehicle: the "Grav Platform." Introduced at tech level 9, the grav platform is an early forerunner of the individual's grav belt. It is less technically complex and costs nearly half as much as the grav module and harness array.

It is a versatile little vehicle: a barrel-shaped, open-topped craft with just enough room for two individuals to stand inside. Grav generators and the power plant are located at the base of the vehicle; the crew stands above this with their upper bodies exposed.

Theoretically, the vehicle can attain speeds in excess of 720 kph. In practice, of course, such speeds are not obtained because the exposed crew could not take it. Some models are equipped with a windscreen, and, instead of holding two standing crew, are fitted with a single seat. These vehicles can approach the maximum speeds allowed. Usual operating speeds vary between 40 and 100 kph, with 40 the maximum safe speed when flying in nape-of-the-earth mode.

Grav platforms are used for a variety of purposes. They make excellent recon vehicles and are frequently employed on patrols or as part of a perimeter security establishment. For night operations, a platform can be fitted with a removable pintle mount and a searchlight.

The basic **Traveller** data for the grav platform is given below.

### Grav platform (Tech Level 9)

Cr62,000; .25 tons. A small, grav-powered craft intended for paramilitary scouting and general support operations. Similar in principal to the air/raft and the G-carrier, it is capable of speeds of up to 100 kph under normal circumstances and is subject to wind effects as an air/raft. Refueling is required after 50 hours of continuous operation. The grav platform carries a driver (who operates the craft using grav vehicle or air/raft skill) plus a single passenger who may serve as a gunner if weaponry is mounted. The vehicle can carry 100 kilograms of cargo. It may reach orbit, is open-topped and is unpressurized.

Although considered a Vargr vehicle due to its frequent use by Vargr corsairs and military units, the vehicle is frequently found in non-Vargr hands as well. A model similar to the one described here is manufactured by GSLAG in the Imperium, and Vargr-manufactured models are frequently imported by firms such as Oberlindes and Akerut. Because of its versatility and comparatively low price, the grav platform finds many applications in everything from starport cargo handling (with suitable modifications, of course) to scout survey work to military uses.

**Striker Information:** The grav platform can be created through use of the *Striker* vehicle rule as modified in Andrew Keith's

"Civilian Striker Vehicles" article (*Journal* 14). One special note: Standing crewmen are not assumed to take up one cubic meter, but rather only one-half cubic meter since the vehicle is open-topped and they are standing with only half their bodies inside the "chassis" of the vehicle. Either a searchlight or a HMG can be mounted, but not both, and the special rules modification from "Civilian Striker Vehicles", particularly as concerns power plant and cargo size is in force. The *Striker* data for the vehicle is listed below.

### Grav Platform (Tech Level 9)

GDW LIBRARY

The vehicle has a crew of one (two if a gun is mounted), and total capacity of two occupants. It may mount a heavy machine gun, but usually carries no weaponry.

*Height:* 1.6 meters. *Width:* 1.2 meters. *Length:* 1.3 meters. *Total Volume:* 2.496 cubic meter. *Weight:* 1.8213 tons. *Price:* Cr61,552.

*Movement:* Maximum, 720 kph/600 cm; cruise, 540 kph/450 cm; NDE, 40 kph/33cm.

*Movement Effects on Fire:* No fire possible during movement.

*Armor:* All faces (except top), 2. Open-topped.

*Target Size DMs:* +1 low.

*Equipment:* 500 power radio, map box. Searchlight mount optional.

*Power Plant:* .5 mw output fusion power plant consumes .75 liters of fuel per hour; fuel capacity is 40 liters, enough for 50+ hours.

*Weapons:* A pintle-mounted heavy machine gun is optional.

—J. Andrew Keith

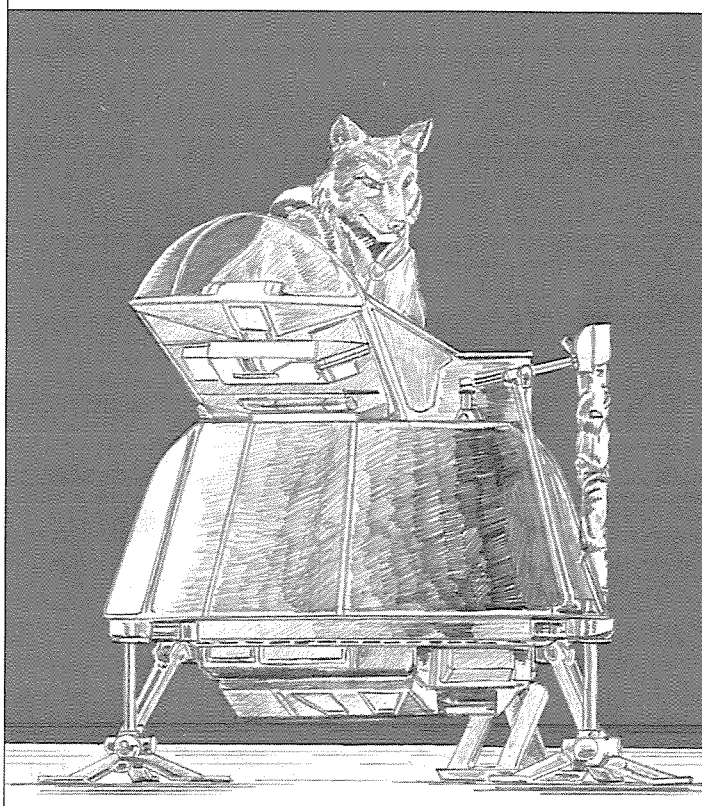

Your team has the  
go-ahead to stop  
**TERROR AT SEA**

A new, hard-hitting  
module for

**DELTA FORCE**  
*America Strikes Back!*™



TASK FORCE GAMES, 1110 N. Fillmore, Amarillo TX 79107

**GAMES ON CALL™**

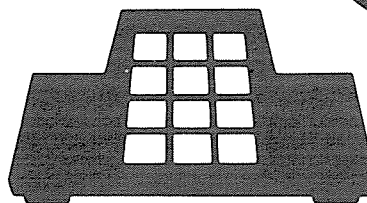
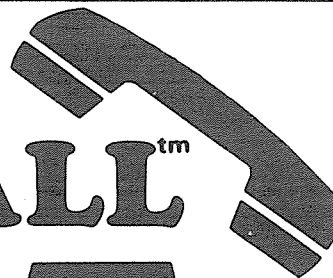

- Call-in Convenience
- Fast, 24-hour Shipping
- No Shipping Charge in US  
(\$1.50 handling fee per order)
- Large Selection
- Credit Cards Welcome
- CODs Welcome
- Express Service Available

**1-800-874-7907**  
TX & FOREIGN 1-806-358-3270

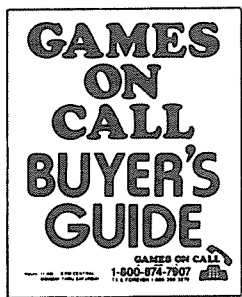

**CALL OR WRITE NOW for  
FREE BUYER'S GUIDE**  
New Summer '86 Edition Now Available!



# The Oegongong

## BESTIARY

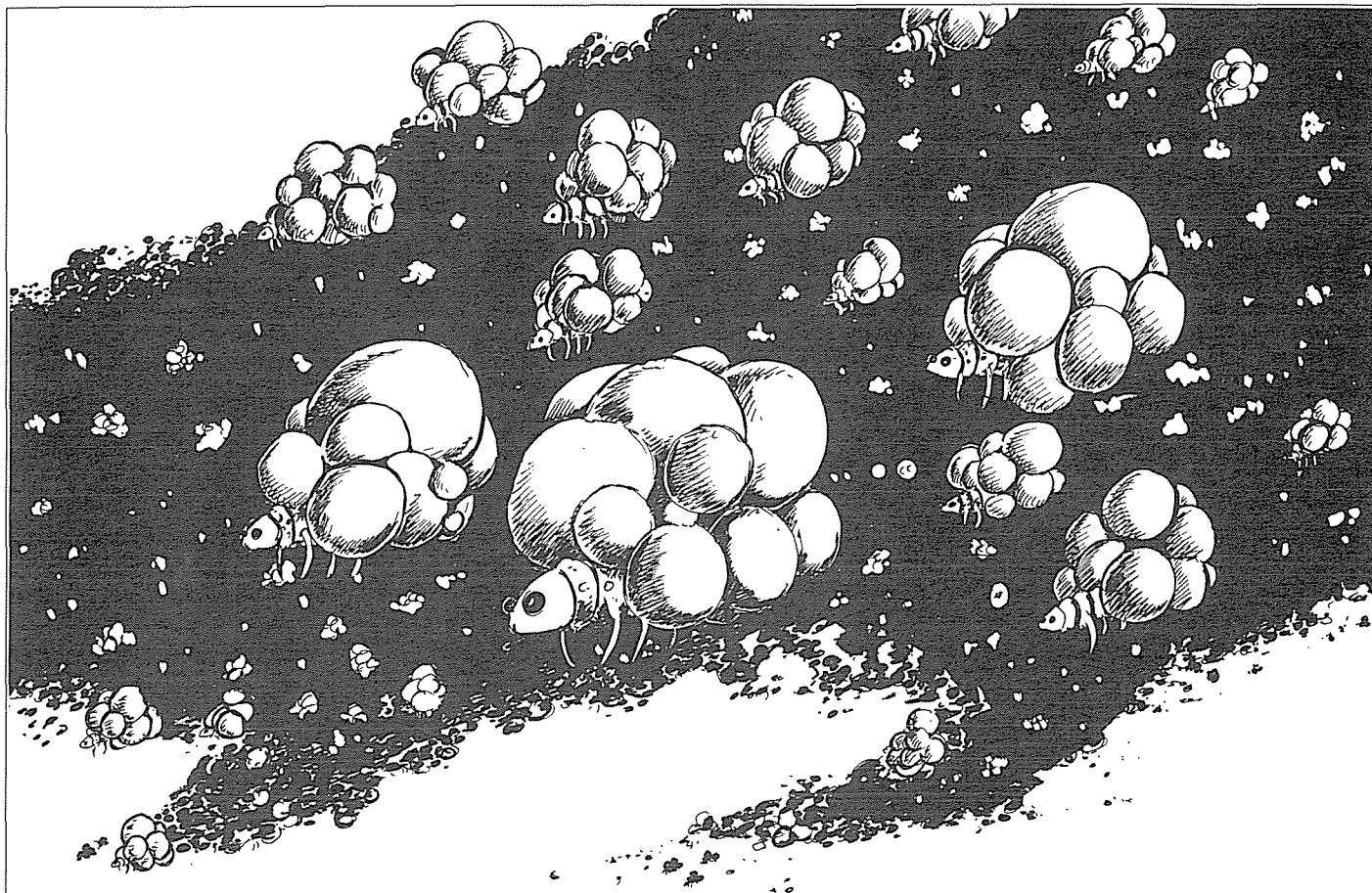

GDW LIBRARY

W.D. STEE

Vargr corsair bands from Gvurrdon first encountered the Oegongong during the great expansion period known as the *Gvurrdon Hvaek*. Records from that period (circa -2650) indicate that the first Vargr visiting Lloursouth believed the Oegongong to be two different and distinct species: one a buoyant flyer born in the water, the other a water- and land-dwelling scorpion. Only later did the Vargr realize that the flyer and the amphibian were, in fact, one creature with a triphibian life cycle.

The Oegongong is an hermaphroditic triphibian omnivore originally native to Lloursouth, but now found on several worlds throughout the Gvurrdon Sector. Hatchlings crawl on land when they first emerge from their egg cluster. The hatchlings immediately seek out water—wallowing periodically in the shallows, while developing gills. As the hatchlings grow, they spend more and more time in the water and less and less on land.

Immature adult Oegongong stay in the water using a biological form of electrolysis to generate hydrogen from the water; the generated hydrogen fills bubble-like sacs on their back. During this period in the Oegongong's life an egg-cell

mass begins production inside its body, causing it to swell.

After a time, the hydrogen sacs make the Oegongong buoyant enough to float just below the surface of the water. The sacs continue to expand until they become huge and balloon-like with enough lift to pull the Oegongong from the water into the air as a free-floating adult, its body swollen with a great mass of egg-cells.

As the adult drifts over land, egg-cells are dropped periodically to the ground over a period of several days. With fewer egg-cells in its body, the adult becomes lighter, drifting higher into the atmosphere until ultimately the balloon sacs expand and burst, killing the adult Oegongong.

When the egg-cells strike the ground the zygote material mixes and fertilizes the eggs, which then begin development. The jelly-like eggs are covered with a gummy, black, sticky mass that cements them firmly onto rocks, foliage, or tree trunks. Many ground animals consider the eggs to be a great delicacy, eliminating most of the thousands of eggs normally produced.

For its size, the Oegongong has a stinger that is especially potent and painful. The stinger is capable of an unlimited number of stings, which means an attacking Oegongong can

potentially kill any animal if it can sting it enough.

In addition, an Oegongong will eat or attempt to eat almost anything so that many animals (particularly the smaller ones) steer clear of them. The tough rubberlike exoskeleton of the Oegongong makes it a generally undesirable food for all but the largest carnivores. Also, the Oegongong's stinger is active throughout its three life-stages, which further discourages other animals from disturbing it. On the worlds where it flourishes, the Oegongong generally has few natural enemies.

Adventurers in the Gvurrdon sector may encounter the Oegongong on any world of size 5 or less with a thin or thin tainted atmosphere (UPP codes 4 or 5) and a hydrographic percentage of 30% to 80%.

The Oegongong's sting is painful and multiple stings can kill if the characters are not careful. Fortunately, only one Oegongong is generally encountered at a time—they rarely travel in groups.

Adult Oegongong with their hydrogen sacs present a considerable hazard to flying vehicles: a collision causes a damaging explosion. Another hazard the players may encounter is an egg-cell bombardment by an adult Oegongong. Handling both possible situations is discussed in the events below.

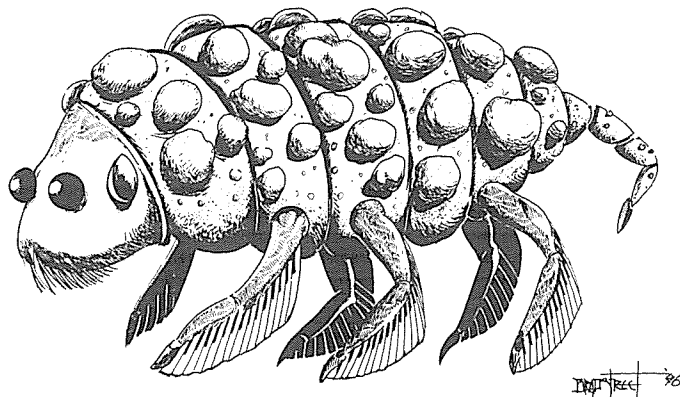
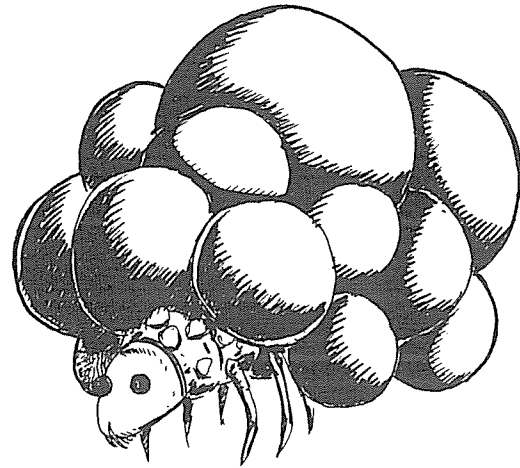

“The Oegongong’s sting is painful and multiple stings can kill if the characters are not careful.”

The stats for the Oegongong are as follows:

**Animal Type      Weight Hits Armor Wounds & Weapons**

Triphibian Eater	1kg	6/0	jack	6 stinger
				(land) A5 F5 S2
				(water) A3 F5 S2
				(air) A0 F4 S1

**Event:** Possible midair collision with an adult Oegongong. Character piloting the craft must roll 11+ to avoid the collision, with DMs of +1 per level of applicable vehicle operation skill, + DEX/5 (drop fractions). If a collision occurs, treat as a single, point blank hit with a laser rifle (4D).

**Event:** Oegongong egg-cell bombardment. Characters must each roll their dexterity or less to avoid getting hit with an egg-cell mass. Those hit with an egg-cell mass must roll their strength or less to remove the sticky mass (only one attempt is allowed per 10 minute period). Other characters may also make an attempt to remove the sticky mass by rolling their strength or less (takes another 10 minute period per attempt).

—Joe D. Fugate, Sr.

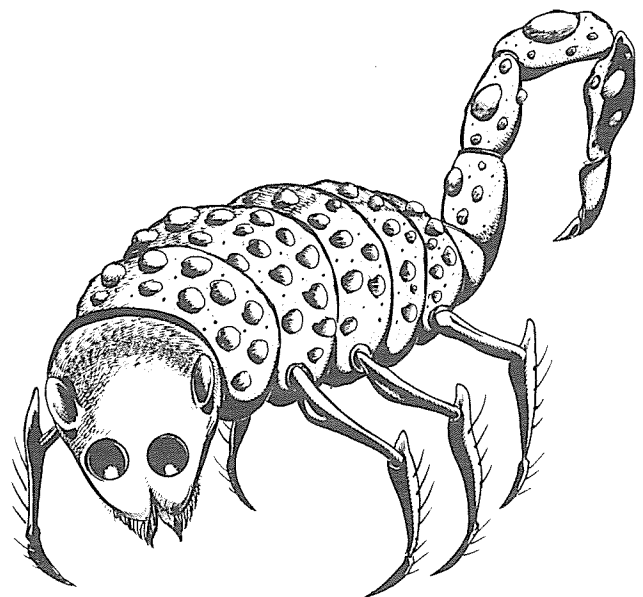

GDW LIBRARY

# Three for the Road

SMALL  
CARGOS**CARGO: GC96/B****Lots:** 1 kg each (750 doses + packaging)**Value:** Cr50 per lot**Transport Price:** Cr30 per lot**Transport Cost:** None**Market:** Standard Item. Restriction +2**Availability:** 10+**Special Handling:** Extremely subject to temperature effects. Keep refrigerated at all times.*Player's Information*

GC96/B is a pharmaceutical developed comparatively recently by researchers in the employ of SuSAG, the megacorporation which is most often connected with chemical and pharmaceutical research. It is a specific against Denebian Spotted Fever, a mutated virus of high communicability and frequently devastating effects.

The disease is transmitted by carriers who are themselves generally immune to it; they may suffer a slight illness after being exposed but recover quickly. The disease may then lie dormant for some time until triggered by environmental factors (which have not been as yet identified with any exactitude, but which would appear to be connected with life in artificial environments—shipboard living, or asteroid or domed colonies). Then the disease spreads to those who come in contact with the carrier (unless a secret saving throw of 10+ is made for each potential victim).

Those who contract the disease will come down with it after a period of 1d days. Symptoms include nausea, high fever, delirium, and an outbreak of dark red spots on the face, torso, hands, and arms. The disease rages for 2d days, during which time 1D damage is taken each day. Attendant medical skill reduces the time by one day per 3 levels of skill, and the damage by one point per 3 levels of skill on each damage roll. Once a character has had the disease, however, he or she will be subject to recurrences every so often, determined as the referee desires. Relapses last only 1D days.

GC96/B, when administered, gives the attending characters the equivalent of an additional medical-9 skill while treating outbreaks of the disease. Doses are in

1-gram pill form; 1 dose per day is required until the disease has run its course. Doses must be kept refrigerated prior to use as temperatures above 50° C cause the drug to break down rapidly into a worthless, inert substance.

*Referee's Information*

Roll 1 die, and apply the following:

1 Prior to shipment, this batch of the drug was not properly handled and was exposed to room temperature for a significant length of time. It is now useless. This will be discovered upon delivery. An investigation to determine responsibility will cause the crew to be denied clearance for 2D days, DM-1 per level of admin. skill (or DM-2 per level of legal skill if using Special Supplement 1, Merchant Prince) of the captain or officer in charge of the ship's records.

2 During the long flight refrigeration machinery fails. The characters have 2D hours to make repairs before the temperature becomes too warm for the drug. Roll 10+ per hour to accomplish repairs, DM + mechanical skill of one repairing character (or per 2 levels of JOT, if mechanical is not available); DM+1 per hour spent making the repairs after the first. If the referee determines that repairs are not made in time, characters will be held liable for the cost of the damaged merchandise.

3-4 An outbreak of Denebian Spotted Fever occurs on board the ship in transit (either a character has been exposed previously, or a passenger brings it on board). The drug is stocked on shipboard only if the Availability throw is made. The alternative is to appropriate the cargo to avert the worst effects of the disease. Roll again; a result of 1 or 2 applies as described above to the cargo. If the cargo is used, the characters are liable for the full value of the shipment (not just the portion used). Also, the ship will be placed in quarantine on arrival until 6 days after the last day of damage to any victim of the disease. As long as the ship is in quarantine it must remain in orbit and may not discharge passengers or cargo or have direct contact with any other person or vessel.

5-6 No ill effects. Shipment poses no special problem.

**CARGO: !!XUG'K (HIGHLEAF)****Lots:** 1 kg each**Value:** Cr25,000 per lot (Cr25 per lot)**Transport Price:** Cr1250 per lot (Cr1 per lot)**Transport Cost:** None**Market:** Restricted Item. Restriction -5. (Luxury item. Restriction +2)**Availability:** 12+ (7+)**Special Handling:** None*Player's Information*

It's called !!Xug'k in K'kree space where it is grown, but humans know it as highleaf, one of the most potent addictive drugs known to man.

Highleaf is a luxury item for K'kree traders. It is a mild narcotic, no more harmful or effective in the K'kree system than a glass of wine to a human. But humans find highleaf far more intoxicating: a 10-gram dose of highleaf (which sells for Cr250 on the streets) gives the user a powerful feeling of euphoria and giddiness for a 12-hour period. During that time, dexterity and intelligence are decreased by 1 while endurance is increased by 1. When it wears off, endurance returns to normal—but the other affected stats return only if a roll against the character's current (modified) stats is less than or equal to those levels. Moreover, once a human has chewed highleaf, a roll less than or equal to endurance must be made once each day for a number of weeks equal to 15 endurances. Failure of any of these rolls results in the slow onset of withdrawal symptoms. The character requires another dose of the drug within 2D hours or suffers 3D damage. The worst thing about the drug is the way that the craving can emerge, suddenly, many weeks after the last consumption of the drug.

The drug is highly illegal on most human worlds, and the Restriction modifier is applied to the roll for the punishment inflicted for possession as well as to the import/export legality rolls. For the most part the weed is unobtainable in human space because of these serious restrictions, but human smugglers often slip into K'kree space to import the drug from there. In K'kree

space the drug is perfectly legal, not particularly expensive and easy to obtain. A few stashed lots of highleaf can set up a drug smuggler for life.

#### Referee's Information

Roll 1 die, and apply the following:

1 The cargo of leaf was improperly cured. This results in far more dangerous effects; users take 3d damage immediately in addition to normal effects, and, moreover, on a roll of 10+ suffer an additional 2D hits applied against intelligence and education; this is an especially severe form of shock amnesia. A recovery is possible only on a roll of 12+ (DM + attendant medical skill) made once each month. Education can be recovered through lengthy, expensive re-education processes (per the Experience rules). While suffering these effects, level -1 skills become level-0 skills and higher levels are reduced to level-1. Introduction of this dangerous form of the drug will result in an intensive search for the criminal and can lead to full murder charges when prosecuted.

2-5 The planetary authorities of the destination world have received a tip that a load of leaf is on its way and are being doubly vigilant. Customs inspections will find the leaf on a throw of 8+. Bribery of officials or particularly clever methods of concealing the cargo could allow DMs, of course.

6 No ill effects. The shipment poses no special problems.

Note: Parenthetical information on the cargo data is for K'kree space; other listings are for human space.

#### CARGO: WOLFE'S BLACKSTREAK

Lots: 25 kg each

Value: Cr500 each

Transport Price: Cr25 each (per jump)

Transport Cost: Cr4 each (per week)

Market: Luxury Item. Restriction -1

Availability: 8+ (outside Spinward Marches, 10+)

**Special Handling:** Live cargo. Noted transport cost is for conscious transport; low berth costs Cr1 for up to 5 animals in a common berth who share the same recovery die roll. Transport price is generally the same either way.

#### Player's Information

The animal known as Wolfe's Blackstreak is described fully in the Bestiary in this issue; it is an animal which is popular for sport or as a guardian beast for rich owners. They are relatively common in the Spinward Marches, somewhat less so outside the Marches. They can be quite valuable but somewhat hard to handle on occasion.

#### Referee's Information

Roll 1 die, and apply the following:

1-2 The animal(s) being shipped is not domesticated (wild breeding stock is frequently transported). If shipped conscious, the animal(s) will find transport disconcerting. Twice a day at feeding time, roll to see if a frightened blackie attacks the crewman assigned to feed the cargo. Otherwise, no effect.

3-4 Some blackies have shown a decidedly bad reaction to the drugs used in preparation for low berth. For each blackstreak carried roll 2D; on a 9+, the animal in question is allergic to the drugs and dies in transit. The ship's doctor is responsible for examining the creatures before they are put under (roll Education or less, DM-xenomedicine). If the roll is successful, the problem is noticed and trouble forestalled. If it failed, the doctor can be sued for up to 10 times the value of the animal. Roll 2D - 2; on a 0, there is no suit; otherwise the suit is for that multiple of the value of the animal. The suit is found in favor of the plaintiff on a roll of the law level of the destination world or less.

5-6 No ill effects. The shipment poses no special problems.

—J. Andrew Keith

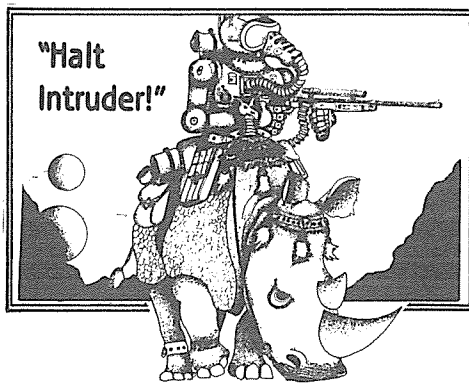

Stop and check the new Compleat Strategist catalog for all your favorite sci-fi and fantasy titles. Write today for your free catalog with hundreds of games in every category.



ORDER TOLL FREE 800-225-4344 Amex/MC/VISA \$10 minimum

## CONGRATULATIONS

The Compleat Strategist stores are your *Twilight: 2000* supply depots at nine locations. We have the full line of Adventure Modules, like **Red Star/Lone Star** and we carry the approved *Twilight: 2000* miniatures by Grenadier. Drop in and check us out.

**IN NEW YORK**  
THE COMPLEAT STRATEGIST, INC  
11 East 33rd St  
New York, NY 19916  
(212) 685-3880

THE COMPLEAT STRATEGIST  
320 W 57th St  
New York, NY 10019  
(212) 582-1272

**IN MASSACHUSETTS**  
THE COMPLEAT STRATEGIST  
(Strategy & Fantasy World)  
201 Massachusetts Ave  
Boston, MA 02115  
(617) 267-2451

**IN VIRGINIA**  
THE COMPLEAT STRATEGIST  
(Strategy & Fantasy World)  
105 E. Broad St  
Falls Church, VA 22046  
(703) 532-2477

**IN NEW JERSEY**  
THE COMPLEAT STRATEGIST  
215 Glenridge Ave  
Montclair, NJ 07042  
(201) 744-6622

**IN FLORIDA**  
THE COMPLEAT STRATEGIST  
5406-8 Stirling Rd  
Davie, FL 33314  
(305) 961-5660

**IN MARYLAND**  
THE COMPLEAT STRATEGIST  
251 Park Ave  
Baltimore, MD 21201  
(301) 752-1493

**IN PENNSYLVANIA**  
THE COMPLEAT STRATEGIST  
254 West DeKalb Pike  
Valley Forge Shopping Ctr  
King of Prussia, PA 19406  
(215) 265-8562

THE COMPLEAT STRATEGIST  
(Strategy & Fantasy World)  
2011 Walnut St  
Philadelphia, PA 19103  
(215) 563-2960

# Grandfather's Worlds

One of the aspects of the **Traveller** universe that has always intrigued me is Grandfather—Yaskoydray, the original Ancient. Since **Traveller** players share this interest, I spent some time working out one of Grandfather's projects as the basis for a number of adventures. This article paints with broad strokes what can be found when adventurers encounter Grandfather's hidden worlds in the Regina system.

In the course of Grandfather's activities before, during, and after the Ancient War, Grandfather translated a large number of worlds out of normal space and created portals which gave him and his robots access to them. In some cases, the world included a star which provided illumination, warmth, and a natural environment. In other situations, he took only a single world, but then created an artificial sun and even artificial gravity to make the world comfortable.

Some of these worlds were created experimentally before Grandfather began the long Ancient War. Many were produced during the war (not only by Grandfather, but also by his children). And a few were created by Grandfather after the war was over. One place in which he worked his technological magic was the Regina system.

## THE HIDDEN REGINA SYSTEM

The Regina system once had more worlds than it does today. Grandfather, in the years immediately after the Ancient War, built a laboratory there. He selected a large gas giant (in orbit 5) along with its three satellites and rotated them into a pocket universe. Using technology he discovered during the Ancient War, he ignited the gas giant, transforming it into a very small star which he named Braykossa. Its small mass meant that it would shine for a very short time, probably less than a million years (but that would be enough for Grandfather's purposes). Harnessing gravitational stress in the pocket universe, he shifted the three satellites into equidistant positions along an orbit and placed observation stations on these planets and left them to record the evolution of the mini-star. When he was finished, he left on other business. He hasn't been back to the Regina system since the year -290,000.

Observation stations can be any number of things. They could be banks of instruments, or totally automated sensor arrays. In the Braykossa pocket universe Grandfather created three separate observation stations on the three separate worlds. By creating three distinctly different stations, he hoped to compare the data they collected and learn even more by correlating the differences in observation techniques.

**Elkyulm:** Grandfather named the first world Elkyulm and populated it with solid-state mechanical robots. He hard-wired into their brains an overriding purpose to observe and analyze the astrophysical life of Braykossa. These gleaming, metal-cased robots devote their lives to detailed observation and analysis of Braykossa. In 290,000 years they have not only developed an accurate record of the star's history, but have also generated a comprehensive theory which predicts the future life cycle of the star.

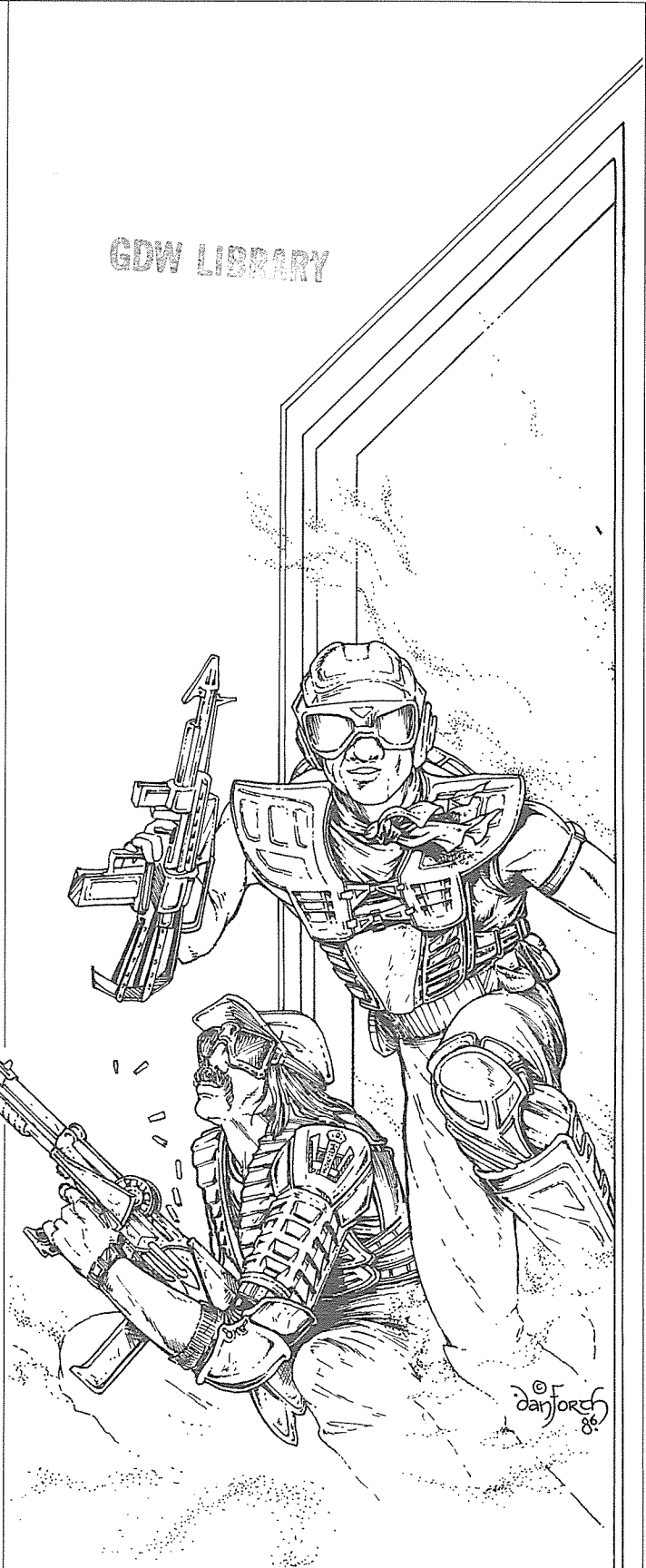

**Kraldosk:** Grandfather named the second world Kraldosk and built on it an automated vat that could create biological robots (androids) which were near duplicates of humans. He placed in charge of this world and its vat a single human servant (named Na Kraldosk) who had shown outstanding loyalty and support throughout the Ancient War. Na Kraldosk was given explicit instructions to maintain a cadre of scientific monitors to observe the life cycle of Braykossa, and he has done so. The vat, however, has also given Na Kraldosk the ability to prolong his own life and he still lives on Kraldosk managing and maintaining the android population of the world.

**Prissuls:** Grandfather named the third world Prissuls, and on that world he established a special life form sensitive to the light of Braykossa. The small, five-legged beasts respond to the specific peak wavelengths of Braykossa's light on the genetic level, and as the star ages the animals (also called prissuls) change in temperament and form. All were originally herbivorous, but as peak light wavelengths have shifted more and more have become omnivorous or carnivorous. Grandfather reads data on the life cycle of Braykossa directly from the nature of the population of Prissuls.

**The Central Control Station:** Grandfather also created a small central control station to monitor the three worlds and to maintain the data produced by them. When Grandfather visits the system, the central control room is where he begins his tour.

The central control room is staffed by a small number (less than a dozen) of loyal robots (called controllers) which he built specially for this purpose.

**The Stairway to the Stars:** Grandfather's controllers in the Regina system of worlds built a way to walk (!) from one world to the next. Hundreds of 'pearls' were built, each one an iridescent sphere about one hundred kilometers in diameter. On opposite sides of each pearl were placed portals which directly connect to other pearls. Strings of pearls led from one world to the next, connecting the three worlds around Braykossa in a necklace of portals.

Each pearl is about one million kilometers from the next. Pearls near the worlds are closer together. The portals in the pearls transport individuals instantly to the next pearl. Because the pearls themselves are so large, the greatest amount of time is consumed in traversing the pearls themselves. In zero-G (some have no artificial gravity), a pearl can be traversed in about ten hours. Other pearls have small environments or habitats and can take from twenty hours to several days to traverse. Walking from one world in the Braykossa system to another requires travelling through about one hundred pearls and takes about one hundred days.

Each pearl is iridescent when viewed from outside; from inside its shell is transparent and gives a view of space, Braykossa, and the three worlds. The controllers have created a variety of environments in the pearls: some are filled with water; others are empty, air-filled bubbles; still others are mini-habitats with foodstuffs growing for the nourishment of travellers.

The pearl chains touch down on the worlds at immense stations where a pearl (100 kilometers in diameter) is embedded in the surface of the planet. The portal opens onto a platform about one kilometer in diameter and twenty meters above the world surface. Potential travellers must first ascend the platform before beginning their journeys; arrivals must leap down from the platform to reach the world.

**Human Imitations:** The vats of Kraldosk can produce nearly exact imitations of any human. They are, in fact, exact with the exception that all are missing the little finger on their left hand (this was an identification technique which Grandfather included in the basic specifications of the vat).

Na Kraldosk has also used the vat to produce replacement parts for himself... he is now over 290,000 years old and has replaced body parts time and again. The only remaining original parts are a very old and crippled left little finger and his original brain.

**The Storefront:** Very recently the human robots of Kraldosk reached a new breakthrough in portal technology and (unknown to Na Kraldosk) succeeded in creating a portal which reached the true universe. They have not yet grasped the full extent of their discovery and think of the new world they have reached as just another in their own universe.

What they have done is to establish a secret research outpost on the world they reached—Regina. Their outpost is a small storefront in Regni, a major city on Regina. They have succeeded in learning the local language and they sell small handcrafted items in order to raise money to buy goods and to finance expeditions on Regina.

**The Necklace:** The controllers built a scale model of the stairway to the stars when they finished their project. This miniature, in the form of a necklace, consists of three large pearls (representing Elkyulm, Kraldosk, and Prissuls) connected by hundreds of smaller pearls (representing the pearls of the stairway to the stars). The entire necklace is about one meter in length. A golden clasp is located halfway between two of the worlds and represents the central control station. It is attached in such a way that it does not touch the adjacent pearls directly.

The necklace has a mechanism to indicate its precise location within the Braykossa system. The pearl or world corresponding to its current location warms to the touch and is visible in the infrared. The effect is subtle enough that it is not usually noticed. A wearer may notice the effect by chance or after careful examination.

The necklace also controls the portals of the pearls. Whenever two pearls are placed adjacent to each other, they override the normal portal relationship and make the portals connect between those two pearls. It is possible to use this technique to shorten travel time between worlds considerably. This technique is also the only way to gain access to the control center.

#### UNIQUE PEARLS

Each pearl is unique, and this uniqueness provides a **Traveller** referee with an opportunity to present puzzles, enigmas, and problems for the adventurers to solve. The following are a few suggestions for pearls.

**Water Bubble:** The pearl is filled with water and travel across it seems impossible without special equipment. Near the portal, however, is a bubble of air drawn from the previous pearl. The adventurers must figure out how to cross the water pearl. There may be convection currents which will carry a pinched off bubble of air across to the other portal. There may be swimming animals (similar to dolphins) which will help. Or the characters may have technological equipment which will help them.

**Air Bubble:** The pearl is empty but filled with air. It has no gravity, so the characters must propel themselves across the 100 km gap by just leaping. They may encounter local life forms as they drift through the clouds of the pearl.

**Gravity Faces Out:** The inner surface of the pearl may have an artificially induced gravity which makes that surface out. The adventurers will have to walk from one portal to the other.

**Other Possibilities:** There are hundreds of pearls, and each is different if only in subtle ways. There may be jungles, mazes of tunnels or corridors, steamy hothouses, frigid ice platforms, and any number of other inspirations. There are two overriding factors to remember: each pearl is different, and it is possible to travel between worlds by using the pearls.

**ADVENTURING**

Against the background of Grandfather's hidden worlds in

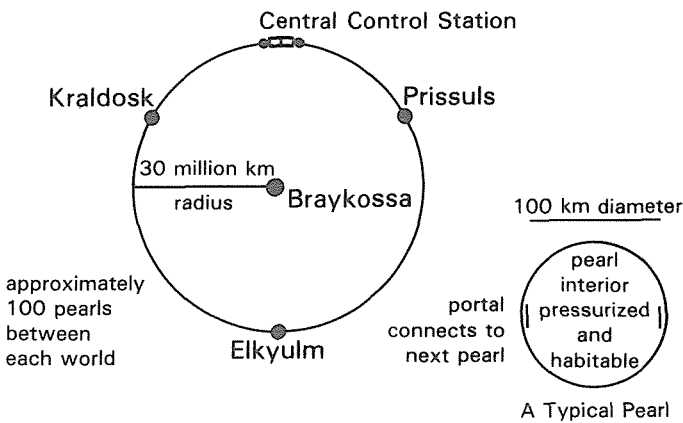

the Regina system a band of adventurers can have a variety of interesting adventures. The following are a few suggestions.

**Come Help Us:** A small delegation of humanoid robots from Kraldosk approach the adventurers for assistance. The beasts of Prissuls have reached an eater phase (where a large proportion are now genetically eaters). Moreover, they have reached a rudimentary level of intelligence and are spilling out over the string of pearls. They have now sprawled over more than half the pearls between Prissuls and each of the other planets, and through an accident have even overrun the central control station. The adventurers are asked to travel to the Braykossa pocket universe and help repel the prissuls menace.

**Go Investigate:** One of the handicrafts that the humanoid robots have sold on Regina is the string of pearls necklace and it has ultimately ended up in the hands of the adventurers. Now controller robots are tracking down the string of pearls and closing down the storefront. They attack the adventurers, leading them to the storefront where they stumble onto the portal and then into the Braykossa pocket universe. Pursued by the controllers, the adventurers must race through the worlds of the pocket universe trying to find their way back to their own world.

**Trapped by Circumstance:** The controllers have discovered the humanoid robot outpost on Regina and are closing it down. In their investigations they have found that some humanoids have had finger transplants to disguise themselves on Regina. Now the controllers have mistaken one of the adventurers for a humanoid robot and grab him to return him to the Braykossa pocket universe. In their sweep they carry all of the adventurers off, and once on Elkyulm the party must find its way out of the pocket universe and back to Regina. —Marc W. Miller

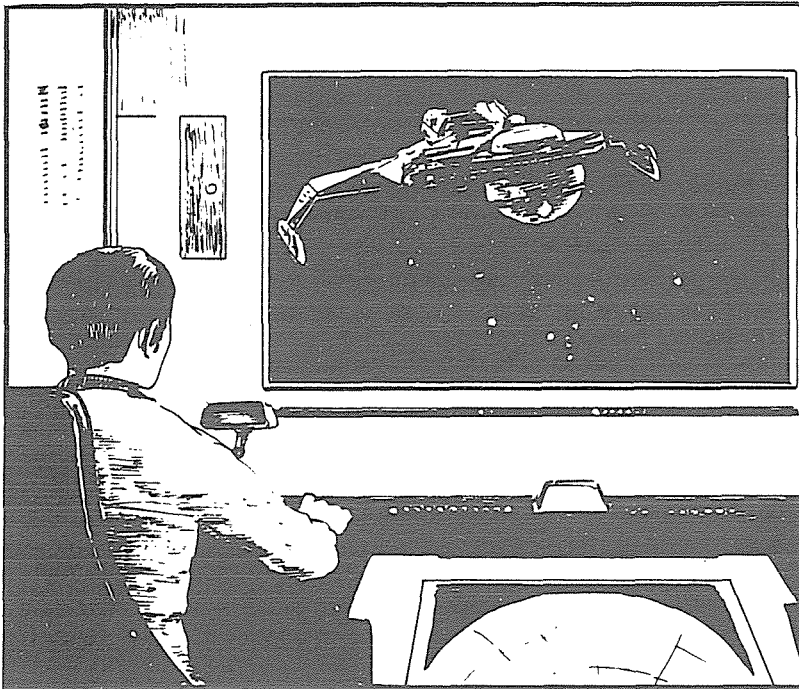

**Introduction to Star Fleet Battles**  
 Now Available! Designed by the Amarillo Design Bureau.

**TASK FORCE GAMES**  
 1110 N. Fillmore Amarillo, TX 79107

# Test-Drive a Starship!

Now you too can accept the challenge of starship command. All the excitement of a warp-speed dogfight awaits you in *Introduction to Star Fleet Battles*. Learning to command a starship is only six easy-to-grasp steps away. Better still, the solitaire scenarios that follow each lesson allow you to learn the basics by yourself.

Let *Introduction to Star Fleet Battles* put you in the command chair!

# Traveller: 2300

## DESIGNER'S NOTES

**Traveller: 2300** is GDW's new science fiction role-playing game, but the conceptualization, design, and development of the game has taken more than a year. During that time, the GDW staff working on the project has thought and rethought just about every possible approach to a high quality science fiction game and sought out the best possible approach.

From a design standpoint, I adopted a guiding phrase early in the process—playable realism. My aim was to produce a game that had the utmost in realism, but was also totally playable. Realistic games that aren't playable tend to sit on the shelf; playable games that aren't realistic are unsatisfying. I made it a goal for **Traveller: 2300** that it would be both. One of the central concepts in the philosophy of playable realism was the concept of tasks.

### TASK RESOLUTION

Ten years ago, **Traveller** introduced skills for characters, defining what they were able to do in a way that made playing the game easy for both the referee and the players. Recent advances in game design have introduced the concept of tasks. **Twilight: 2000** used task definitions to describe basic activities using in the game. In parallel with that, the *Digest Group* established a Universal Task Profile for **Traveller** in their quarterly **Traveller Digest**, and over the past eighteen months has refined and revised the concept to make it more playable and more comprehensive. A corresponding task system for **Traveller: 2300** was defined early in our design process and became an integral part of the game system, being used in ship combat, personal combat, and even character generation at the most basic level.

Tasks produce a realistic, reproducible feel to **Traveller: 2300** while making basic activities very playable. Each task defines an action to be performed. Additional information in the task definition indicates the skills required, the difficulty level involved, and the time required to accomplish the task. special referee notes also indicate consequences, exceptions, or special circumstances.

Difficulty levels range from easy through routine to impossible. Skill levels are a modifier on the throw for success, as are personal characteristics. Time for the task is handled in such a way that it produces an average time for task duration, but better skill levels reduce the required time (some tasks also take no time, or take a specific amount of time).

Failed tasks have realistic consequences that range from frustration to death. tasks can be repeated if the character can stay determined enough (and staying determined is itself a task).

There are also special types of tasks. Hasty tasks take less time, but become more difficult. Hazardous tasks have more dangerous consequences of the task fails. Unskilled tasks allow anyone to try, without a penalty for lack of skill (although having the required skill can still help).

My favorite, however, is the uncertain task; it is used to resolve situations where the players cannot know for a certainty the outcome of the task. An example might be diagnosis of a mechanical problem: the player may attempt the task, but

does not know if he has successfully figured out the problem.

In an uncertain task, the player rolls for success and can tell from his die roll if he has succeeded. at the same time, however, the referee rolls for success secretly. If both referee and player succeed, the referee produces results that are total truth. If one succeeds and one fails, the referee produces results that are only partially true. If both fail, the referee produces results that are totally false. You can see that diagnosis might take several attempts before a player can be certain he has found the fault.

Setting fuses for demolitions is an uncertain task contained in the **Traveller: 2300** rules. It is classified as easy, and anyone with any skill will usually succeed. Once in a while, the referee will roll a failure while the player succeeds: somehow the fuse setting failed (although it looks OK) and the explosive won't detonate when the proper time comes. And once in a while, the player will roll a failure (and immediately realize that he has wired the explosives wrong); he can rewire them immediately to try to fix the fault. And sometimes, the player will roll a failure and hear the referee tell him the charges have exploded—because the referee also rolled a failure. The entire procedure is an example of the playable realism that pervades our entire **Traveller: 2300** game system.

### OTHER PARTS OF TRAVELLER: 2300

Task resolution is not the only part of **Traveller: 2300** that we spent a lot of time on. Frank Chadwick produced an excellent personal combat system, and he wasn't above making the great movie tricks (such as leaping attacks and wrestling holds) part of the action. The GDW staff simulated the course of history from 2000 to 2300, creating a totally plausible, consistent future which reflects developments of technology, and centuries-old power struggles. Tim Brown crafted a space combat system that plays well and also reflects realistic future battle systems. I built on my **Traveller** researches to develop a realistic system that creates star systems with a minimum of effort.

*Next Month:* The **Traveller: 2300** star map—the most accurate star map ever produced for a game.

### THE RELATIONSHIP OF TRAVELLER: 2300 TO TRAVELLER

The common name for **Traveller: 2300** and **Traveller** leaves some room for confusion, and it helps to clear that sort of thing up early. Frankly, I consider **Traveller** one of the best games ever designed. To quote a recent review, it "set the standard for science fiction games."

**Traveller: 2300** is not advanced **Traveller**; it is a completely different game. The similarity of names is due to the continuing dominant theme in each game: players are travellers to the stars. **Traveller: 2300** is not intended as a direct replacement for **Traveller**. They have different backgrounds, different approaches, different rules. **Traveller** is going to be around for a long time, and we will continue to support it. **Traveller: 2300** is an alternative game system that incorporates new game technology and a different approach to background. The two game systems can co-exist and will for years to come.

—Marc W. Miller



# The North American Research League

## HISTORY

During the latter half of the twentieth century, a time later to be considered the start of the peace and environmental preservation movement, several popular organizations emerged almost simultaneously. Though the languages and backgrounds of these organizations ran the gamut of the entire world community, their goals were essentially the same—to fight against the injustices and atrocities committed by humans against each other and the only planet then available.

These peace organizations gained popular support around the world, and thus, financial backing,

through the media of the time: mainly television. Pictures on the evening news of volunteers in the face of impossible odds, battling with impersonal governments or corporations in the process of poisoning the environment, drove a charitable machine aimed at the betterment of the human condition. Historian Francois Dupage would later remark that the period of popular support for these organizations “rivalled both the American and French Revolutionary wars as a popular movement from the masses provided backing for these ecological rebels.”

The world problems of the time were many. World hunger was attacked by the charitable machine until it was virtually wiped out of existence. The destruction of incredibly large numbers of animals for their fur pelts and other cosmetic purposes was appalling, and thus targeted by the ecology movement. Dumping of toxic materials and garbage into the oceans, the near panic of the ozone crisis of the late 1980s, unnecessary nuclear testing by the superpowers, and the placement of thousands of nuclear weapons near population centers in Europe were the chief issues of the time. However, no issue did more for the entire ecological movement than international whaling.

Since the 19th century, whaling was an important industry for many seafaring powers. However, by the 1970s there were only two significant participants remaining: Japan and the Soviet Union. Political and social pressures did nothing to end the wholesale slaughter of whales until the late 1980s when ecological organizations began to turn up the heat. The Soviets gave in to public pressure and ethical logic and got out of the whaling industry.

However, Japan held out until the infamous “night of blood”



on May 18, 1993. In a well orchestrated move, anti-whaling fanatics doused the downtown areas of Tokyo, Osaka, and Nagasaki with thousands of gallons of whale blood collected from Japanese whaling stations. The gore of the scene appalled the Japanese public sparking them into action. By October 3 of the same year, Japan was among the signatories to the international Whaling Ban. A blow had been struck for decency, and a great victory had been won.

**A Foundation is Born:** The very forces which backed the whaling movement, though, were so great as to be overwhelming. Endowments were so large

that charitable contributions became an afterthought when compared to returns on investments. Investments were the key; ecological movements invested in ecological business and industry. Pro-environment became the byword for industry until the idea became ingrained in the psyche of world industrial leaders—so much so that the idea survived the destruction of the Third World War.

Industries most willing to conform to ecological points of view were predominantly centered in North America. Also, a large portion of the charitable support for the ecology movement was based in the United States. Before the war, the groundwork was laid for organizing most ecological groups into one entity—the North American Research League. The originator of this movement was Dr. John Fox. His efforts brought together fanatical and reasonable elements from all around the world to headquarters in New York and the League became quite famous for its distinguished supporters and members. Fox and most of his associates were killed in the aftermath of the war, but their contributions and their dreams were never forgotten by the faithful.

The immediate postwar world was not ready for the League or its good works. Survival took precedence, and the environment was already in desperately poor shape. However, since the League was almost completely uninterested in investment in either military or petroleum industries, their investment base suffered little in the war. A large amount of money supported League activities all around the world, mostly focussed on the distribution of food and medical supplies. With the help of the Alberta Farmer’s Cooperative, grain was shipped by an ad hoc fleet of rusty vessels around the world, spreading not only famine relief but good will as well.

**A Crisis of Management:** Coexistence with the French government during the French Peace brought the League to its greatest power in the beginning of the 22nd century. However, partnership with the French was not without its problems as French interests began to take precedence over vital ecological issues. As an extension of French interests, League ethics were set aside in favor of political ends and the League lost the respect of the world for nearly a century.

During a time when League ideals were most necessary, when new planets were being discovered and colonized (and in many cases exploited) League management was "out to lunch," as it were. However, as French power in the world declined, its power over the League and its activities also waned, but slowly. The rebirth of the League was under the leadership of, ironically, a Frenchwoman—Anne Bourge.

**Planet Cleanup:** In the absence of true League direction, colonization of the local neighborhood had gone unchecked by any ecological interest. Anne Bourge set the wheels of what was once a great organization into motion once more, using the cleanup of colony worlds as her goal. With a purpose in mind she was able to overcome French influence over League affairs, get the organization moving again, and break out into the stars all in one move.

Specific instances of exploiting the newfound wealth of the stars without regard to environmental impact are numerous. The chief offenders were nations virtually ripping planets apart in the desperate search for tantalum. One particular offender in this vein was the American government. Caught with the technology but not the tantalum reserves to fully enter the interstellar game at the onset, the Americans set out on a rampage in search of the vital material. Deposits confirmed on planetary bodies in the Clarksstar and DM<sup>1</sup>26 12026 systems were relentlessly exploited at the expense of lifeforms evolving peacefully there for millions of years. Direct intervention closed down these operations, at least temporarily, until correct life-preserving measures were taken to extract the tantalum without destroying the ecosystem.

Along the French Arm, Triad Industries had laid claim to a living planet in the Augereau system. Metal deposits virtually covered the surface of the world and extraction by strip-mining techniques was vastly profitable, even though most of the raw ore had to be transported back to markets on Earth or Tirene. Unfortunately, the sulfurous waste products of the mining project were carelessly dumped into the water oceans killing off the native (albeit, primitive) lifeforms. League intervention into the Augereau-4 issue was too late to prevent the disaster, but legal action taken after the fact forced Triad Industries to settle out of court with the League setting up a trust fund and policing unit within its own ranks to prevent future mishaps of this nature.

**Consciousness Raising:** While specific instances still crop up which the League finds necessary to police, the greatest effort of the foundation is making the public aware of the problem. A long term program to do just this (over a century, in fact) has been quite successful. The consciousness of the human race has never been more ecology minded, both at home and for all human worlds. By changing the way people think before they act, the League is stopping problems before they begin. Eventually, foundation policy dictates, there will be no need for the League and its activities—its actions will slowly eliminate

its necessity. However, a century is scarcely enough to perform such a task, and the need for the League and its ideals is very necessary in 2300.

Currently, the League is heavily involved in the moral issues concerning the Sung and their Xiang slaves in the DM<sup>4</sup> 123 system (current exploits by the League on this front are described in detail below). Human public support for this mission is widespread and headstrong. The League is the moral guiding light in this issue and freeing the slaves from their oppressors has become the single issue which keeps the League in the limelight of public attention.

## SUPPORT

There are several types of support which are vital to the continued good works of the North American Research League.

*The Support of the Public:* Probably the most vital to the success of the organization. Individuals in the private sector include laymen and celebrities—celebrities often used to increase public support.

*The Support of Governments:* Without the good will of governments the League could scarcely carry on its works. Since governments are often the chief offenders in the mind of the League, the world court must often uphold their rulings. As a whole, however, the League enjoys great support from the nations of Earth and the human sphere of influence.

*The Support of Industry:* Industry is slightly more reluctant to show active support for the League. The dictates of the League which can be enforced are virtually always at the expense of industry. Profits often come first, to the point where it is not uncommon for industry to conduct its activities in secret to avoid League intervention.

## ORGANIZATION

The League is organized very loosely considering the scope of its activities. There is a board of directors headed by a single person in the chairman's role. The board is responsible for allocating funds and organizing task forces, keeping overall control over the direction of the foundation.

Task forces are organized around a single issue (the Xiang slaves, for example, or a single planetary ecology). The board of directors appoints a single individual from the ranks of the organization to head the task force. These individuals have enormous latitude in how they wish to organize the foundation's efforts toward effecting change in their areas.

The leaders of task forces within the League are characterized as being very charismatic figures, championing their specific causes with all their energies. Their direct control over the problems makes them much more accessible to both the press and to individuals, so that they are in the public eye more often than not. This is a great responsibility since it is public support which powers the League and its activities. Becoming the head of a task force within the League is the dream coveted by all League employees.

All other League operations fall directly under the control of specific task force leaders. Everything from public relations on a matter, to research, to disruption or intervention is organized and carried out by the task force. This makes the figure of a task force leader quite important—an individual often sought after for endorsements or other favors of an influential nature.

## SCOPE

The League is involved in issues throughout human space. There are no human colony or outpost worlds where one cannot locate a League office of some sort.

**Ships:** The League owns and operates a number of vessels, mostly of an exploratory nature. Ships which have been discarded by governments or corporations because of age often find their way into League service. However, in the last 50 years there has been a movement in the foundation's leadership to modernize the fleet, mostly for public relations purposes, and several ships have been newly built for the League.

**Personnel:** The League employs over 100,000 persons scattered across all three arms of human exploration. The home office is in Chicago where roughly half the employees of the foundation work as public relations personnel and administrators. The board of directors works from here to direct the League's operations. Task force leaders most often travel to Earth to make their reports; rarely do board members actually leave Chicago.

Beyond Earth, employees range from photographers, to mechanics, to space crews. For every employee on the frontier, however, there is usually at least one volunteer willing to do his part for the cause. Volunteers are encouraged to work with the League as opposed to being independent. Their efforts are rewarded with awards and certificates of recognition, and, occasionally, cash rewards.

## ADVENTURES AND THE LEAGUE

**Referee:** What follow are ideas for adventuring with the League in your campaign. These can be used as they are, or they can be expanded upon. Their purpose is to get the League involved with the player characters and to impress upon the players the influence which foundations have on life in **Traveller: 2300**.

**Coverup:** It is not uncommon for industries to keep certain activities secret, especially activities which are damaging the ecology of a planet. This is perfect material for an adventure involving the League.

League operatives will approach the player characters, pointing out that there is some reason to suspect the corporation in question of ruining a planetary ecology. The incentive for the player characters might be in the form of possible cash rewards, a previous beef with the corporation, or a simple sense of duty to protect planets from such damage. In any case, the characters will hook up with some number of League personnel and the group will travel to the system in question to gather evidence.

If the player characters do not possess a ship the League will provide one. Since the corporation in question wants to keep its operation quiet, it will either be very well hidden or very well protected. Either way, the mission is to gather evidence (hard evidence, photographs, documents, etc.) which will hang the corporation in the world courts, and return with it safely back to Earth.

**Bodyguards:** The life of a League task force leader is often in danger. His efforts can affect multi-million livre deals and disrupt business and profits. This makes him a good target for assassination or more covert actions.

Such a figure might approach the player characters with a job offer. A task force leader can always utilize the experience of talented individuals in a variety of missions. They might be called upon to accompany the leader to Earth so that he can present his progress to the board in person. They might be expected to run courier missions for him, or even travel to trouble spots to collect information independently of other League operations.

**The Xiang:** The operation to free slaves from the Sung at DM + 4 123 has been given priority by the League board of directors. However, Manchurian interests are also in play and their influence over the issue has been felt.

Specific missions to free slaves can be created: freeing some slaves from a remote mining operation in the system, for instance, or taking over a Sung ship and liberating some Xiang from their oppressors.

The Manchurian secret services are also keeping an eye on just what is going on between the League and the Sung. An adventure involving the Xiang liberation may not even involve them or the DM + 4 123 system—it may be between the player characters and the League and the Manchurians, all far removed from the problem.

**Exploration:** The League likes to keep a constant flow of exploratory missions moving just outside the frontier, mapping planets and asteroid belts, checking orbits, and looking for new potentially profitable locations. However, League funds are not limitless, nor are their human and material resources. Oftentimes a task force leader charged with exploration of a certain area of space is given insufficient support from the League and must rely on locally recruited personnel and ships. This is where the player characters come in.

Nearly any system beyond the frontier worlds might be the subject of a League expedition. A scenario in which a task force leader hires a group of player characters and their ship to perform such a mission would be very straight forward. The leader would probably offer some cash reward for exploring a system, though this sum will probably not be very high. Payment might, however, be less tangible. For instance, the influence of a task force leader might get the player characters out of a tight spot at a future date, so they might consider accepting the mission as a favor. Also, it will be likely that the leader will want one or more League personnel to accompany the expedition to observe and assist.

The actual exploratory mission itself might involve just mapping out the system in question. Deeper missions might require the team to visit the life zone planets and examine any life they might find there. Specimens might be sought after, and would have to be captured and given proper life support on the return trip. The possibilities are virtually without limit.

**Permanent Employment:** The possibility of gaining permanent employment with the League is not completely out of the question. However, acceptance depends mostly on merit. League funding is often low, and they cannot afford an excess of personnel, not matter what their qualifications might be.

A player character who covets a position with the League will have to do volunteer work for them first. Any of the missions mentioned above would be appropriate. Making friends with a task force leader would also be helpful. The road will be a long one, but the League will recognize the service of a dedicated and skilled individual.

—Timothy B. Brown

# Cain



**Ex-Marine Captain 9C9DA7, Age: 40, 4 terms. Cr Variable.**

**Skills:** Rifle-3, Demolition-3, Streetwise-4, Carousing-2, Dagger-2, Grav Vehicle-1.

Cain is a terrorist, dedicated to the overthrow of Imperial power and the reestablishment of Solomani domination in the Solomani Rim.

He was born on a small world on the Solomani side of the border, then carrying the name Franz Fitzkloff. He decided to enlist in the Solomani Marines and at the age of 23 he was sent to OCS. He received commando training and was later transferred to intelligence. His superiors realized his ruthless character and sent him on a very demanding kind of mission. He went into the Imperium to work with the organizing anti-Imperium terrorist groups on Solomani dominated worlds. As usual Captain Fitzkloff performed well, committing several acts of terrorism himself.

When he returned to ordinary duty some years later he found it too uninteresting. He also disagreed strongly with the current policy towards the Imperium, considering it too submissive. He resigned from service at the age of 32. Before leaving his job he managed to destroy several important files about himself and his activities. He left the Solomani realm and went into the Imperium to work with the friends he had made. His *nom-de-guerre* became Cain, picked from the book of Genesis.

Today, eight years later, Cain has a fearful reputation as an efficient and competent terrorist. No one but himself knows the full record of his crimes. There have been bombings, assassinations, sky-jackings, robberies, and much more.

Cain no longer looks like Franz Fitzkloff. Plastic surgery has given his face a nondescript Caucasian look, with well-balanced features. He excels in assuming false identities, using imagination and whatever means there are at his disposal.

Cain's motivations are simple. He is a Solomani chauvinist who sincerely believes in the superiority of the Solomani race and who wholeheartedly hates the Imperium because of the Solomani Rim War and the humiliating conquest of Terra. He is a clever and competent, but totally ruthless fanatic. The ends justify the means. Within these concepts lies a weakness that might one day prove his undoing.

The players could encounter Cain in many ways. They could involuntarily become involved in one of Cain's murder attempts. This situation could be very interesting if played in a confined space, such as a starship or a domed colony. The players could unknowingly become a part of Cain's organization. This could prove very challenging when the players discover what kind of people they have become involved with and set out for revenge. Finally, they could work for an Imperial agency that is trying to capture or kill Cain.—*Anders Blixt*

# SPACEGAMER

# FantasyGamer

# IS BACK



GDW LIBRARY

Space Gamer / Fantasy Gamer magazine is returning well in time for Christmas, and with so much to herald, we want to make sure you get the right gift! Space Gamer magazine has been published for eleven years, and has served Science-Fiction and Fantasy gaming fans faithfully through the years. It is a magazine with a long history, an outstanding reputation, and now it's having a glorious rebirth.

**The new Space Gamer / Fantasy Gamer** magazine will be appearing in stores and mailboxes throughout the land by December. Issue number 77 will mark a new era of creativity for one of the longest-published magazines in the hobby.

The new Editor is Anne Jaffe, formerly of Game News magazine. Anne is not only one of the industry's most qualified (and esteemed) editors, she is also energetic, organized, devoted, punctual, and has a great eye for the details that make all of the difference in a quality magazine product.

The new Art Director is Vince DeNardo, currently Art Director for both Fire & Movement and Computer Gaming World magazines. Vince is giving Space Gamer / Fantasy Gamer a new look, dynamically improved over previous issues, and an advance for all magazines of this genre.

**Even the publisher is giving you more with the new Space Gamer / Fantasy Gamer.** An increase in size from 48 to 64 pages (while still keeping the current cover price) is one heck of a fine gesture. They're not stopping there, however, because this notice also includes the following new subscriber deal:

**Bundles of FREE issues with your paid subscription!**

That's right, get a 3-issue trial subscription for only \$9.50 and pick out any bundle of back issues, or try a 6-issue one year subscription for only \$18.00 and pick out any **two** bundles of back issues, or get a full 12-issue two year subscription for only \$35.00 and pick out any **three** bundles of back issues.

Please include an additional \$3.50 for one, \$5.50 for two, or \$7.00 for three bundles of back issues to pay for shipping and handling; Canadian addresses please add an additional \$1.25 per bundle; overseas an additional \$2.00 per bundle.

Please specify which bundles of back issues you want. Each contains from five to thirteen issues of Space Gamer and Fantasy Gamer magazines grouped together by the common theme of the major articles in them. Bundles may also be purchased separately for only \$6.00 each (postage paid in the US, Canada add \$1.25 per bundle, overseas add \$2.00 per bundle).

- BUNDLE A: AD&D/D&D #1
- BUNDLE B: AD&D/D&D #2
- BUNDLE C: Traveller #1
- BUNDLE D: Traveller #2
- BUNDLE E: Ogre/G.E.V. #1
- BUNDLE F: Ogre/G.E.V. #2
- BUNDLE G: Car Wars/Killer
- BUNDLE H: Play-by-Mail
- BUNDLE I: Complete games in every issue
- BUNDLE J: Everything else #1
- BUNDLE K: Everything else #2

**The best fantasy and science-fiction reading awaits you in issue after issue of Space Gamer / Fantasy Gamer magazine. Join the adventure today!**

All payments must be in US funds and drawn on a US bank. Make all checks payable to DTI, P.O. Box 8399, Long Beach, CA 90808. (213) 423-3675.

ENCLOSED IS MY \$ \_\_\_\_\_. I AM SUBSCRIBING TO THE NEW SPACE GAMER / FANTASY GAMER FOR \_\_\_\_\_ ISSUES. PLEASE SEND ME THE BUNDLES OF BACK ISSUES I HAVE CIRCLED BELOW:

NAME \_\_\_\_\_

ADDRESS \_\_\_\_\_

CITY \_\_\_\_\_ STATE \_\_\_\_\_ ZIP \_\_\_\_\_

SEND BUNDLES    A    B    C    D    E    F    G    H    I    J    K

# Journalism and the Stars

In the **Traveller** universe the trader in information, the journalist, is an important man. Through such men vital data are gathered, processed, and directed to the people that can profit from them. The journalist does not work only for the media. He has all kinds of customers for his information.

Within the Imperium there are several agencies specializing in information trade. The most well-known is TNS, run by the Travellers' Aid Society. But there are many others that deal mainly with corporations and governments, and thus are less known to the public. These range from huge, Imperium-wide corporations to agencies covering only parts of a subsector.

For all agencies in the information business, it is very essential to maintain a reputation for credibility and balance. Because of this, the agencies are very careful to maintain their independence from outside interests. The corporate statutes usually regulate ownership of voting stock thoroughly.

The major agencies have offices and bureaus all over the Imperium and on many important worlds outside its borders. You usually find bureaus on all Imperial worlds with population 8+, and on most non-Imperial worlds with population 9+.

A world bureau is responsible for covering events within its own and the neighboring solar systems. The subsector bureau is usually located at the subsector capital. It gathers data from the world bureaus and covers events within the subsector that cannot be covered by the world bureaus. The sector headquarters are mainly occupied with the processing and distribution of news, but it also deals with extra-sector activities.

But not even the big agencies are able to cover all matters of interest, especially in areas outside the Imperium. Here the free-lance journalists have their important role. However, the agencies are very careful with material they acquire from outsiders. An erroneous story could easily damage the agency's reputation. The agencies prefer to buy stories from well-known tradesmen on whose qualities they can rely, thus journalistic fame takes on more importance for free-lancers.

The legal status of journalists varies widely from place to place. In free countries, the authorities respect the journalist's rights to investigate within the frame of the law. But in many places, freedom is a matter of little importance for the government, and journalists face troubles practicing their profession. Common sanctions used against journalists are refusal to grant entry into a country, arrest and confiscation of material followed by extradition, constant surveillance by authorities, and in really bad cases, accusations of espionage followed by prison sentences or outright assassinations. When a player journalist faces troubles with the local authorities, the referee must determine what measures will be taken. The only governments that provide good working conditions are types 2, 4, and 8.

Journalists that get into trouble with the authorities will often have to rely on their own abilities to get out of it. The agencies will give their men whatever assistance they can, but since communications are slow and it can be difficult to send a message from many places, they will often stand helpless.

Journalist characters played by the gamers should always be freelancing when working within their profession during play. Working as an employee within an agency will surround them

with orders about what they are expected to do and not to do, and would thus hamper their freedom of movement.

## CHARACTER GENERATION

**Enlistment:** Any character wishing to become a journalist must first pass through journalism school. Such schools are available on all worlds with pop 7+ and tech 5+. The roll to enlist is 8+ with DMs, +1 educ 7+, +2 int 9+. This education lasts two years and gives the journalist two skills: Journalism-1 and one die roll on the office skills table.

**Career:** After leaving journalism school, the character starts his ordinary career. Following the standards set down in earlier **Traveller** material, it is counted in four-year terms, divided into four one-year assignments. At the conclusion of a term, the character can try to re-enlist or leave the profession.

A character can pursue two different careers: free-lance or agency. The free-lance career is open to all journalists. To be hired by an agency, the character must roll 9+ (DM +1 if Soc 7+, DM +2 is Int 9+, DM +1 per fame point). A character can try to be hired by an agency at the beginning of every four-year term. An agency journalist can switch to free-lancing between two terms with no restrictions. The re-enlistment roll is 6+ for free-lancers and 5+ for agency journalists.

**Assignments:** Every year the character must determine what assignment he will have during the year, and then resolve the assignment in terms of survival, fame, and skills. To obtain any of these three things, the character must roll equal or higher than the numbers in the resolution table with 2D. The exact assignment is determined by the roll of one die.

Fame is a measure of how well-known the journalist is. It is important for two matters: when the journalist tries to be hired by an agency, and when he tries to sell an article to an agency.

**Special Duty:** When a character receives special duty, roll 1D and consult the table.

**Survival Training:** The character is sent to survival school. Roll 1D 4+ for the following skills: Survival, Gun Combat, Hunting, Brawling, Jack-o-T. In the future all assignment rolls of 2 are dangerous service. The character receives permanent DM +1 for survival (this bonus can only be received once).

**Journalist School Teacher:** Receive one level of instruction.

**Space Training:** Receive one level of Vacc Suit, and on a roll of 1D 3+, one level of zero-g-combat.

**Starship Training:** Roll 4+ for Pilot, Navigation, and Engineering.

**Language School:** Learn one foreign language.

## ASSIGNMENT DETERMINATION TABLE

<i>Free lance</i>	<i>Agency</i>
1 Field mission	Office
2 Field mission	Office
3 Field mission	Field mission
4 Dangerous mission	Field mission
5 Dangerous mission	Dangerous mission
6 Unemployed	Special

**Explanations:** *Office:* The character works in an agency office, processing material, and writing background stories. *Field*

*mission*: The character is sent somewhere to investigate something. *Dangerous mission*: This is a field mission to a dangerous area, e.g. a war zone. It gives the character one experience point when determining morale according to Book 4 rules. *Unemployed*: The character has no proper work this year and survives by taking temporary jobs.

#### ASSIGNMENT RESOLUTION TABLE

##### Free-lance

	Survival	Fame	Skill
Field	3+	10+	7+
Danger	4+	8+	6+
Unemployed	auto	no	9+

##### Agency

Field	3+	10+	7+
Danger	4+	9+	6+
Office	auto	no	8+

#### SPECIAL ASSIGNMENTS

##### Die Survival

- 1 Survival School
- 2 Journalism School Teacher
- 3 Space Training
- 4 Starship Training
- 5 Language School
- 6 Language School

*Journalism*: This new skill is the ability to make good saleable material, both with text and pictures. When a free-lance journalist wants to sell a story, he must roll 2D 11+ (DM journalistic skill and fame). He is paid fame × Cr80/day of production

(double if the material was gathered in dangerous conditions).

#### SKILL TABLES

	Journ	Office	Field	Free-L	Unemp.
1	Journ	Admin	Vehicle	Pilot	Gambling
2	Journ	Admin	Survival	Journ	Carousing
3	Bribery	Computer	Vehicle	Forgery	Admin
4	Carousing	Computer	Gun	Carousing	Computer
5	Streetwise	Journ	Ship's Bt	Streetwise	Streetwise
6	Jack-o-T	+1 Educ	+1 Endur	Jack-o-T	Carousing

**Vehicle**: Choose Wheeled, Tracked, Grav, or Helicopter.

**Gun**: Choose Rifle, Pistol, or Submachinegun.

An agency journalist can always choose either the assignment column or the journalist life column. A free-lancer can choose the assignment column, the journalist life, or the free-lance life columns. Unemployed must use the unemployed column.

#### MUSTERING OUT TABLES

Die Free-lance	Agency
1 Low Psg	1,000 Mid Psg 5,000
2 Mid Psg	5,000 Mid Psg 5,000
3 Gun	5,000 Mid Psg 10,000
4 +1 Int	10,000 +1 Int 10,000
5 +1 Educ	20,000 +1 Educ 20,000
6 High Psg	50,000 High Psg 30,000
7 Scout	100,000 Travellers 50,000

On the material benefits table there is a DM+1 if the character has Fame 4+, and on the monetary table if he possesses Gambling skill. Keep agency and free-lance terms separate since two different tables are used. — *Anders Blixt*

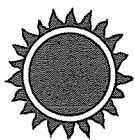

# TRAVELLER NEWS SERVICE

GDW LIBRARY

#### REGINA/REGINA (0310-A788899-A)

Date: 140-1112

¶ A dispatch from Terra/Sol (0207-A867A69-F) dated 130-1111 reads: "The Starship Accident Inspection Team (SAIT) of Australia Down Starport has been officially relieved of its duties in the inspection of the Tyrol, a Rome Inc. luxury liner which suffered mysterious damage while in hyperspace en route to this world. The Naval Attache to Terra, Captain Winston of Duncanhood, Earl of Lardher, officially relieved the SAIT and replaced them with his own team of specialists, including a number of civilian representatives from the Beta Draconis Industries. Heavy security measures, including marine guards, have been implemented, and all access to the Tyrol has been cut off to observers.

¶ Meanwhile medical specialists at the Demosthenes Naval Hospital have confirmed the gradual recovery of Commander Churner from the almost total loss of equilibrium he suffered as a result of exposure to hyperspace."

#### REGINA/REGINA (0310-A788899-A)

Date: 142-1112

¶ A dispatch from Terra/Sol (0207-A867A69-F) dated 132-1111 reads: "The remains of the three engineering crew who were killed in the mysterious mishap on board the Tyrol were identified today as First Mate Jerrance Willan of Hell/Sol, Second Mate Elizabeth Maer of Prometheus, and Cargo Specialist Albaret Michaelsson of Terra/Sol. Their remains are being held pending the conclusion of medical investigation, after which they will be released to their families."

## Assault

"Thorough and intelligent research...is the foundation upon which the designer has erected an elegant simulation."

*The Grenadier*

"Any game should be judged by how well it simulates its subject matter...Assault does an excellent job of modeling its subject."

*Fire and Movement*

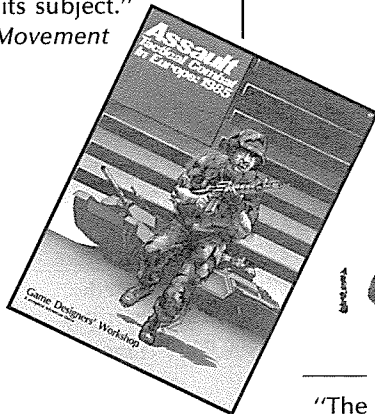

## Boots & Saddles

"Playable and fast moving."  
"Anyone with an interest in modern tactical level games should find a place for this one on their shelves."

*Fire and Movement*

"I don't presently own a copy of Assault but playing B&S has prompted me to look for a copy...when I consider that I haven't bought a boardgame in a long time, I guess that says something about the quality of GDW's product."

*The Wargamer*

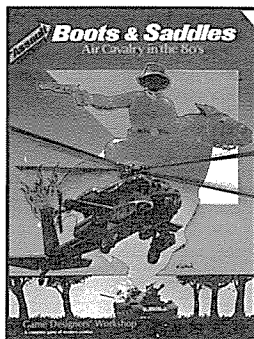

## Southern Front

"The TWW series maintains its high quality in this game."

*The Grenadier*

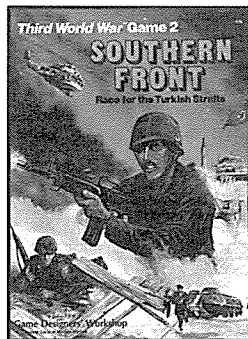

## Third World War

"As close to a definitive treatment as we are likely to get." "Anyone serious about the subject will prefer GDW's treatment."

*The Wargamer*

"Best thing on the topic on this scale."

*S&T*

"A complex game but the clarity of the rules make it easy to play." "The research...gives the game an altogether realistic feel."

*Game News*

"Sophisticated but also very playable." "The sophistication enables the game to flow smoothly."

*The Grenadier*

## Arctic Front

"Frank Chadwick has done an excellent job. My hat is off to him. Bravo!"

*The Wargamer*

"This fine game system seems to get better with each release."

*S&T*

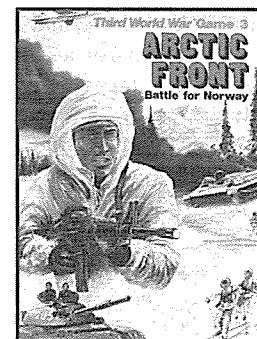

Send for our free catalog!



*continued from page 9*

**Torrance, CA:** Oil refining and storage facilities (.5 Mt).  
**Wilmington, CA:** Oil refining and storage facilities (1.25 Mt).  
**Benicia, CA:** Oil refining and storage facilities (.5 Mt).  
**Martinez, CA:** Oil refining and storage facilities (.5 Mt).  
**Vandenberg AFB, CA:** Recon Satellite Launch Facilities (1 Mt, ground burst).  
**March AFB, CA:** 15th Air Force Headquarters (1 Mt).  
**Cheyenne Mountain, CO:** North American Air Defense Command (NORAD) Headquarters (3 Mt, ground burst).  
**Delaware City, DE:** Oil refining and storage facilities (.75 Mt).  
**Dobbins AFB, GA:** Air Force Reserve Headquarters (.5 Mt).  
**McDill AFB, FL:** Central Command Headquarters (1 Mt).  
**Eglin AFB, FL:** 1st Special Operations Wing (1 Mt).  
**Kennedy Spaceflight Center, Cape Canaveral, FL:** Recon Satellite Launch Facilities (1 Mt, ground burst).  
**Maryport, Florida:** Port facilities severely damaged by near miss (.5 Mt offshore).  
**Honolulu, HI:** Pacific Command Headquarters (1 Mt).  
**Scott AFB, IL:** Military Airlift Command (MAC) Headquarters (.5 Mt).  
**Wood River, IL:** Oil refining and storage facilities (one 1.5 Mt).  
**Joliet, IL:** Oil refining and storage facilities (1 Mt). The army munitions plant near ground zero also took severe damage.  
**Lawrenceville, IL:** Oil refining and storage facilities (.5 Mt).  
**Whiting, IN:** Oil refining and storage facilities (one 1.75 Mt).  
**Cattlettsburg, KY:** Oil refining and storage facilities (.75 Mt).  
**Eldorado, KS:** Oil refining and storage facilities (.5 Mt).  
**Kansas City, KS:** Oil refining and storage facilities (.5 Mt).  
**Baton Rouge, LA:** Oil refining and storage facilities (1.5 Mt).  
**Garyville, LA:** Oil refining and storage facilities (.75 Mt).  
**Norco, LA:** Oil refining and storage facilities (one 1 Mt).  
**Belle Chase, LA:** Oil refining and storage facilities (.75 Mt).  
**Convent, LA:** Oil refining and storage facilities (.75 Mt).  
**West Lake, LA:** Oil refining and storage facilities (.5 Mt).  
**Meraux, LA:** Oil refining and storage facilities (.25 Mt).  
**Shreveport, LA:** Industrial facilities (250 Kt).  
**Washington, DC:** Presidential shelter at the White House (.25 Mt ground burst).  
**Andrews AFB, MD:** Presidential Emergency Facility (.5 Mt ground burst).  
**Fort Meade, MD:** Presidential Emergency Facility (.5 Mt ground burst).  
**Camp David, MD:** Presidential Emergency Facility (.5 Mt ground burst).  
**Sawyer AFB, MI:** 40th Air Division Headquarters (.5 Mt).  
**Pasagoula, MS:** Oil refining and storage facilities (one 1.25 Mt).  
**Sugar Creek, MO:** Oil refining and storage facilities (.5 Mt).  
**Malmstrom AFB, MT:** 341st Strategic Missile Wing (1.25 Mt).  
**Offut AFB, NB:** Strategic Air Command (SAC) Headquarters, 95th Strategic Recon Wing (SR71), 544th Aerospace Recon Technical Wing (1.5 Mt).  
**Linden, NJ:** Oil refining and storage facilities (1.25 Mt).  
**Perth Amboy, NJ:** Oil refining and storage facilities (1 Mt).  
**Paulsboro, NJ:** Oil refining and storage facilities (.5 Mt).  
**Westville, NJ:** Oil refining and storage facilities (.5 Mt).  
**Grand Forks AFB, ND:** 321st Strategic Missile Wing, 319th Strategic Bombing Wing (1.25 Mt).  
**Minot AFB, ND:** 57th Air Division Headquarters, 91st Strategic Missile Wing, 5th Strategic Bombing Wing (1.5 Mt, some

ground bursts).

**Lima, OH:** Oil refining and storage facilities (.75 Mt).  
**Toledo, OH:** Oil refining and storage facilities (1.75 Mt).  
**Ponca City, OK:** Oil refining and storage facilities (.5 Mt).  
**Tulsa, OK:** Oil refining and storage facilities (.5 Mt).  
**Philadelphia, PA:** Oil refining and storage facilities (1.75 Mt).  
**Marcus Hook, PA:** Oil refining and storage facilities (1.5 Mt).  
**Charleston, SC:** SSBN support base and port facilities (.5 Mt).  
**Baytown, TX:** Oil refining and storage facilities (2 Mt).  
**Port Arthur, TX:** Oil refining and storage facilities (3 Mt).  
**Texas City, TX:** Oil refining and storage facilities (1.5 Mt).  
**Beaumont, TX:** Oil refining and storage facilities (1.5 Mt).  
**Houston, TX:** Oil refining and storage facilities (1.5 Mt).  
**Deer Park, TX:** Oil refining and storage facilities (1.25 Mt).  
**Robinson, TX:** Oil refining and storage facilities (.75 Mt).  
**Corpus Christi, TX:** Oil refining and storage facilities (1 Mt).  
**Lemont, TX:** Oil refining and storage facilities (.75 Mt).  
**Nederland, TX:** Oil refining and storage facilities (.5 Mt).  
**Sweeny, TX:** Oil refining and storage facilities (.5 Mt).  
**Borger, TX:** Oil refining and storage facilities (.5 Mt).  
**El Paso, TX:** Oil refining and storage facilities (.25 Mt).  
**Carswell AFB, TX:** 7th Strategic Bombing Wing (.5 Mt).  
**Dyess AFB, TX:** 12th Air Division Headquarters (.5 Mt).  
**Randolf AFB, TX:** Air Training Command Headquarters (.25 Mt).  
**Arlington, VA:** The Pentagon (.5 Mt ground burst).  
**Quantico, VA:** Presidential Emergency Facility (.5 Mt, ground burst).  
**Fort A. P. Hill, VA:** Presidential Emergency Facility (.5 Mt, ground burst).  
**Norfolk/Portsmouth, VA:** Atlantic Command Headquarters, port facilities (1 Mt).  
**Ferndale, WA:** Oil refining and storage facilities (.5 Mt).  
**Anacortes, WA:** Oil refining and storage facilities (.5 Mt).  
**Fairchild AFB, WA:** 47th Air Division Headquarters (.5 Mt).  
**Warren AFB, WY:** 4th Air Division Headquarters (1 Mt).

—Loren K. Wiseman

## GREEN DRAGON HOBBY TRAVELLER® by FASA

### THE HARRENSA PROJECT/THE STAZHLEKH REPORT

This booklet contains not one but two complete **Traveller** adventures!

*The Harrensa Project* deals with industrial espionage on a hostile planet.

*The Stazhlek Report* centers on a commando operation geared to gather vital military intelligence.

### GET BOTH TODAY!

*The Harrensa Project/The Stazhlek Report*.....\$4.50

To order, send check or money order to:

Green Dragon Hobby  
P.O. Box 2573  
Sandusky, OH 44870

Please add \$1.00 for shipping. Ohio residents add 5% sales tax.

Traveller is a registered trademark of Game Designers' Workshop.

**PUT YOUR WANT AD HERE.** Any *Traveller* or *Twilight: 2000* related ads accepted, subject only to space available and good taste. Buy or sell out-of-print booklets. Advertise fanzines. Find people to play against. Challenge Classifieds, Challenge Magazine, PO Box 1646, Bloomington, IL 61702.

**WANTED:** Photocopies of the *Vanguard Reaches* and the *Beyond Sector* (published by Paranoia press) and *50 Starbases* by Judges Guild. James P. Ward, 7907 Wynbrook Rd, Baltimore, MD 21224.

**THIRD IMPERIUM:** A quarterly Canadian *Traveller* fanzine by M. Jackson, A. Berg, and D. New. Each issue contains new equipment and equipment blueprints, starship deck-plans, a complete adventure, and more! \$2.50 Canadian for a sample issue, \$9.00 Canadian for a four-issue subscription. Mike Jackson, No. 512, 4676 Yew St, Vancouver, BC, Canada, V6L 2J6.

**GAMEMASTERS GUILD OF WAUKEGAN:** The Guild invites you to become a member of a gaming guide. This will be a directory of games and people in the Chicago area who play them. There will also be a list available for new people or out-of-town people who wish to find opponents. If you play a game, or have a game club, please get in contact with us at (312) 336-0790.

**WANTED:** Photocopy of *High Passage* No. 1, unpainted Martian Metals 15mm figures and vehicles, and *The Desert Environment* by Gamelords. Jed Docherty, 21 Moran Ave, Princeton, NJ 08542.

**WANTED:** Will players and/or referees of *Traveller* in Lancashire, Yorkshire, or members of the RAF please contact J/T Birchenough I.P. T91 Flt, RAF Staxton Wold, Scarborough, N. Yorkshire, UK, YO12 4TJ.

**WANTED:** Journals 1-4, 6, 8, 11-17. Will pay \$5.00 each, but am willing to bargain on early issues. Dale Allen, 9380 SW Palamino, Beaverton, OR 97005.

**WANTED:** Complete set of 2nd Edition *Striker* rules, in fair or better condition. Dave Strecker, 40 Broad St, Wethersfield, CT 06109.

**WANTED:** TCS players in NYC metro area interested in playing in an Islands Sector campaign. Ronald Finkelstein, 120 Asch Loop, Bronx, NY 10475.

**MACINTOSH TRAVELLER PROGRAMS:** Approved translations of GDW's *Beastary* and *Word Generation* programs for the Macintosh. WordGen/Beastary, \$18.50 plus \$1 postage. Digest Group, 8979 Mandan Ct, Boise, ID 83709.

**TRAVELLER CAPS:** Embroidered "4518th Lift Infantry," or "Azhanti High Lightning" baseball caps. Trantor Merchants, C/O Brad Porter, 329 NE Fairgrounds Rd, No. E103, Bremerton, WA 98310.

**WORKING PASSAGE:** Back issues of Ed Edward's *Traveller* fanzine. \$1.25 each, or

## Classifieds

\$12 for all 12 issues. Full of data, scenarios, situations, and equipment. Contact Ed Edwards, 1410 E Boyd, Norman, OK 73071.

**BETWEEN WORLDS:** *Traveller* fanzine. \$7 for six bi-monthly issues. Between Worlds, 3914 Angeles, Tampa, FL 33629.

**HIGH PASSAGE AND FAR TRAVELLER** back issues (HP 2-5, FT 1 & 2) available, \$4 each. Green Dragon Hobby, POB 2573, Sandusky, OH 44870.

**TRAVELLER A-Z:** 20-page listing of more than 350 approved and non approved *Traveller* items. Includes short description and rating. \$2.25 with plasticized cover; \$1.75 with plain paper cover. Herb Petro, 419 Elmhurst Rd, Belmont, NC 28012.

**4518TH LIFT INFANTRY BADGE PACK:** Regimental crest, Imperial sunburst, Regina shoulder flash. \$10 U.S. Starman Adventure Systems, PO Box 170, Heidelberg 3084, Australia.

**COMPUTER PROGRAM EXCHANGE FOR TRAVELLER:** Public domain programs written for *Traveller*. Contribute your programs. Use ours. Current disk (7 programs) \$3 postpaid, or send a blank disk and return postage. Apple II DOS 3.3 format. Inquiries, please include SASE. John Meyers, 526A Forney Loop, Ft. Belvoir, WA 22060.

**DATABASES:** List of *Traveller* supplements and companies producing *Traveller* material. List of magazines dedicated to *Traveller* and list of *Traveller* novels. List of review authors. List of reviewing magazines. All for \$4.50. W. Andrew York, PSC Box 2315, Randolph AFB, TX 78150.

**BACK ISSUES** (bought and sold): Most *Journal of the Travellers' Aid Society* available. The Weekend Warrior, 8116 Van Noord Ave, No. Hollywood, CA 91605.

GDW LIBRARY

# CHALLENGE

For *Traveller*:

**Sector to Sector:** Essays dealing with adventures spanning the whole Imperium.

For *Twilight: 2000*:

**Aircraft Module II:** More aircraft, more helicopters, and more rules for the *Twilight: 2000* Air Module from issue 26.

For *Traveller: 2300*:

**More Design Notes:** Marc Miller continues his examination of GDW's new RPG.

**Plus:** Our regular features, and more!

Light Cruiser HAZARD calling FLAG  
Light Cruiser HAZARD calling FLAG  
First assault shuttle away . . .  
Am under attack by System Defense Boats . . .  
Port side maneuvering lost . . .  
SEND HELP, REPEAT SEND HELP! . . . message ends

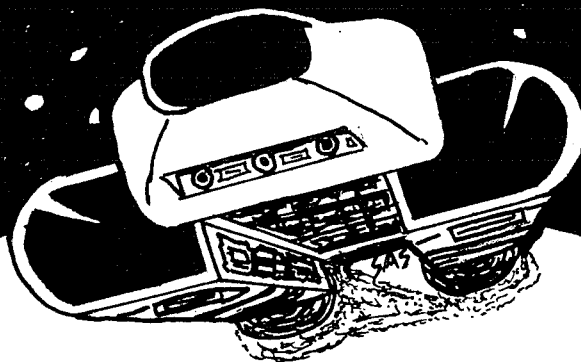
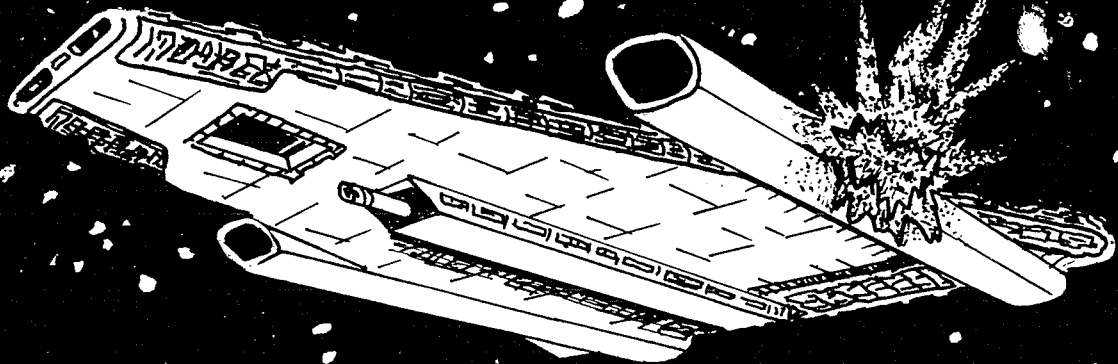

**IN TRILLION CREDIT SQUADRON CAMPAIGN  
YOU CAN**

Design your own warships, transports, assault landers, fighters, tankers, support ships — in short your own Navy, build and organize your Marines and Ground Forces. You can make and break alliances, conduct raids, subversion, take over star systems with military force, or bribery and conduct a full Space and ground campaign.

**OR YOU CAN  
PLAY THE IMPERIAL GAMES**

Design your own warships and fight the 1986 Trillion Credit Squadron Tournament by mail. Earn promotions, decorations and increase your social standing for the Glory of the Empire. The Rules: Traveller — Trillion Credit Squadron and High Guard.

Turn-around time for both games will be in 10 days. Play begins 01 May 1986. Only a limited number of positions will initially be available for the campaign., so enter early. TRAVELLER rule books; TRILLION CREDIT SQUADRON and HIGH GUARD are a must and are available through us or your local game store. The CAMPAIGN set-up is \$25.00 which includes the first two turns, our PBM rules addenda, and your initial fleet/ground forces submission and one resubmission if errors are found in your original fleet/ground forces. Set-up for the IMPERIAL GAMES is \$20.00 and includes the same items as the CAMPAIGN game.

Trillion Credit Squadron is  
an adventure for TRAVELLER  
GDW's role playing set in the  
far future.

**APPLIED GAMING TECHNOLOGIES INC.**  
POST OFFICE BOX 2496  
CLEARWATER, FLORIDA 33517  
MCI MAIL AGTI, CIS 75706, 1010

Journey across the light years exploring the uncharted systems of the frontier; watch your two shadows under a double star; war against the unfathomable Kafers amid the exotic environments of alien worlds; ride the beanstalk down to the towering cities of Earth, the economic center of an ever expanding human civilization. Be a part of the New Age in **Traveller: 2300**—the state of the art in science fiction role-playing.

# TRAVELLER:

# 2300

MANKIND  
DISCOVERS

THE STARS

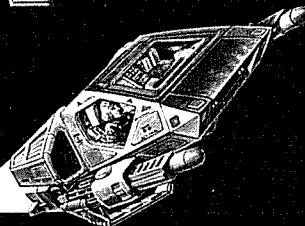

## State-of-the-Art Science-Fiction Role-Playing.

### History

**Traveller: 2300** plays against a background of Earth 300 years after the cataclysm of the Third World War. Set in a world where nations still clash, civilization has crawled back to its prewar levels, and then beyond. The world is dominated by the Third French Empire. Earth's hundred nations have colonies among the stars. First contact happened long ago, and commerce with alien intelligences is now commonplace.

But exploration still goes on. The conquest of the stars has just begun.

### Game Systems

Playable realism. Many games which are realistic can't be played; most playable games aren't terribly realistic. **Traveller: 2300** is both at once, balancing exquisite detail with simple, accurate game systems.

The heart of **Traveller: 2300** is its task resolution system. With it, the referee has a plethora of examples and precedents to use in any situation, and the players have a reasonable idea what their options will be on any given task. Rules cover all aspects of conflict resolution from arguments to all-out battles. Detailed character generation, starship operations and combat, and economics make **Traveller: 2300** the state of the art in science fiction role-playing. If you're playing anything else, you're behind the times.

### The Near Star Catalog

The **Traveller: 2300** universe deals with star systems within 50 light years of Earth. Extensive research and analysis has produced the most accurate star map ever made. Never before has such a monumental task been undertaken, either in gaming or in science fiction. Over 700 stars in over 500 systems, on a 22" x 25" full color map. Location, spectral type, size, and magnitude are all documented in a separate star catalog.

The local neighborhood of stars contains white dwarves, red giants, and warm yellow stars like our own. The map extends far beyond the furthest reaches of human settlement into the realms of aliens and the unexplored. **Traveller: 2300** maps out the local neighborhood in detail never before accomplished, helping to make the game what it was designed to be—the ultimate in playable realism.

**Traveller: 2300** includes complete rules for science fiction role-playing, a complete full color map of everything within 50 light years of Sol with accompanying stellar data, and an introductory adventure set on mankind's frontier. Be a part of the New Age, with **Traveller: 2300**.

**GDW** Game  
Designers'  
Workshop  
Since 1973

PO Box 1646, Bloomington, IL 61702-1646

\$20. Available at your local hobby shop or direct from GDW (add \$1 for handling).  
Send for our free catalog.