

FUTURE WAR

ISSUE 27 \$3.50

**H
E
A
V
Y

M
E
T
A
L**

**THIS ISSUE: *ASSAULT 'MECHS
*FICTION
*REVIEWS**

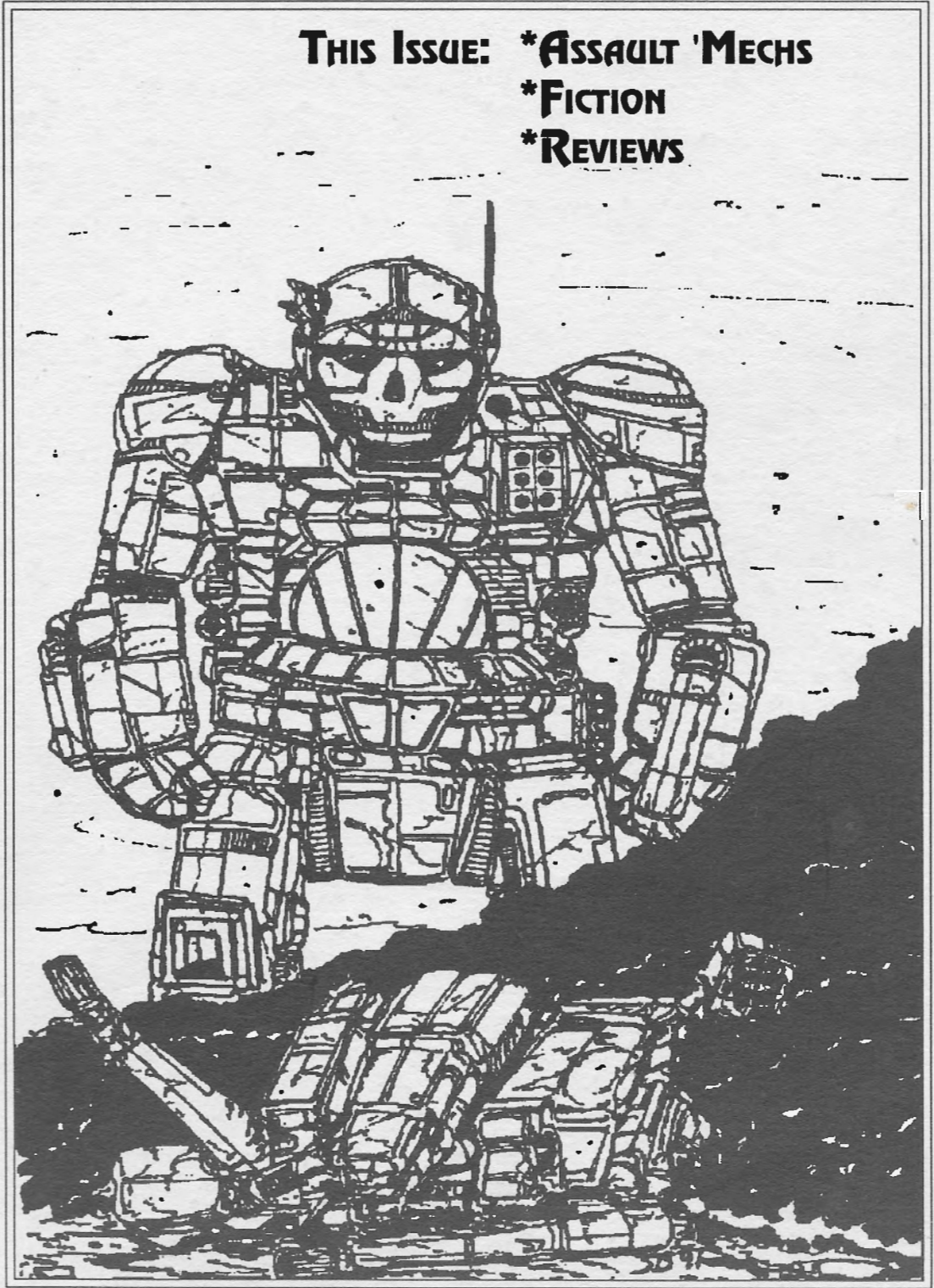

FUTURE WARS

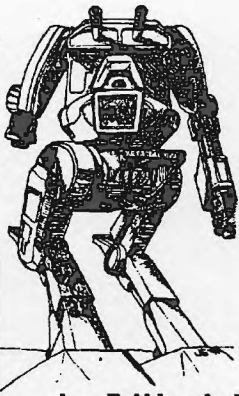

CREDITS

Publisher

Herb Barents

Editor-in-Chief

Herb Barents

**Assistant
Editors**

Phil DeLuca

Pat Hwang

Typeset/Layout

Philip J. DeLuca

Cover Art

Steve Barnett

Interior Art

Steve Barnett

JSG

Ken Lemons

Dave Lovelock

CONTENTS

- 1 **Editorial**
Herb Barents
- 1 **Submission Guidelines**
- 2 **Incoming Transmissions**
The Readers
- 4 **Review: Rhonda's Irregulars**
Pat Hwang
- 5 **Burying the Hatchet**
J. Donald Lail
- 6 **Old Dinosaurs**
Erik Eid
- 9 **The House Rules**
J. Donald Lail
- 11 **Review: Jade Phoenix Trilogy Vol. 1 & 2**
Philip J. DeLuca
- 11 **Review: Solaris VII**
Orion Beadling
- 13 **Special Section: Assault BattleMechs**
- 14 **Assault 'Mech Tactics**
Herb Barents
- 16 **'Mechs Beyond 100 Tons**
Philip J. DeLuca
- 18 **Building the Assault 'Mech**
Herb Barents
- 19 **Real 'Mechs**
Herb Barents
- 20 **Assault 'Mech Modifications**
Philip J. DeLuca
- 21 **New Assault BattleMechs**
Various Contributors
- 47 **Afterword and Store List**
Philip J. DeLuca

FUTURE WARS is issued bi-monthly, and focuses on FASA's BattleTech system. **FUTURE WARS** can be ordered by mail, or found in better game and hobby stores across the nation.

FUTURE WARS Issue 27, Volume II, copyright 1992 Herb Barents.

The graphics on pages 5, 11, 14, 18, and 19 are from FASA's Technical Readout 3050 (pg 5), Solaris VII (pg 11), Map Set #2 (pg 14), and Technical Readout 3025 (pgs 18, 19), copyright 1991 FASA Corp.

by Herb Barents

Can you imagine this is issue #27? The issues have been getting much better. The printer is making this into a really good-looking magazine. All the

help I have had from various people has just been great. There is no way I can tell you how much all of this means to me. Without a lot of people helping me out, there would be no Future Wars as you see it today. I only hope that I will be able to repay these people someday, and I know that I will be able to.

I have finally gotten myself somewhat organized so that things are not slipping through the cracks as they were before. In issue #24, I was given credit for the *Marauder* variant; it should have been Pat Hwang. Please remember-when you send things in, put your name and address on the back of the stuff so that I can make sure you get the right credit and the proper payment that is due you. Please contact me if a mistake has been made. They do happen and will continue to happen, but I can only correct them when I hear from you, the readers.

And now for the monthly call for more things: I need artwork (which, by the way, we pay for just like articles), whether it's just one picture or a bunch. If you're good, I'd like to get you on staff. You'll have to submit usable art for a couple of issues before you become part of the staff. I need to see a bit of your work and I'll need to know that you'll be coming out with more all the time. I do feel that we have had a lot of good art in this 'zine; better than that in other



Battletech 'zines, in fact. I also need articles: scenarios are great, and action reports of games you have played are good as well. More weapons, technology,

new vehicles, and 'Mechs are always welcome. When a new 'Mech arrives, you can figure it will be 6-8 issues before it appears. I do have a great backlog of 'Mechs at this time, but I need more to keep it fresh. The current backlog of articles means that any new article would take 3-5 issues to appear, though I always need more. Reviews appear as soon as possible. Right now as I'm finishing #27, issue #24 has been out a week, #25 goes to the printer in one week, and #26 is on the way back from the typesetter. Thus...I'm three issues ahead of the current one, but maybe you can understand why it takes so long to get your stuff into an issue of Future Wars.

Coming up, Future Wars #28 will be the Battletroops and MechWarrior issue, with in-depth reviews and so forth on *MechWarrior 2*, as well as more on Battletroops and the Elementals game coming out. Number 29 will deal with BattleForce and the larger games. Number 30 will be concerned with the new technology. Number 31 will feature the air combat games: Aerotech, Star Warriors, Silent Death, Interceptor, and others. Number 32 will have thoughts on the new rules, the clans, and all that they relate to, with a lot of debate on the issues raised. Number 33 will have more on the Americal Division and 34 will

have more on the Kins. These issues will appear in 1992: #28 in February, #29 in April, #30 in June, #31 in August, #32 in October, and #33 in December. Future Wars has dropped back by two months over the last couple of years. According to our original schedule, #30 should have come out in April and #31 in June. We'll see if we can get caught up real soon. The Best of Futures #1 is being worked on now. It will have a full-color cover and will feature lots of articles from the first 18 issues. Also in 1992 I hope to bring out The Best of Future Wars: The Tactics and The Best of ... Mechs. Things are looking up on these items right now.

SUBMISSION GUIDELINES

Our guidelines are designed to make sure that you get recognition, are easy to interpret and understand, and can easily be incorporated into our magazine.

1) Typed or letter-quality print-outs of submissions are preferred. This is so we can read it more easily, as well as scan it in better.

2) Print your name on every page of your submission, so we can easily give credit to our authors/artists. Sometimes, signatures and initials are illegible.

3) Number each page of your submission, so we can realize quickly if any are lost.

4) Keep a copy of your submission on file, so we can call for a replacement in case of loss.

5) Send it in NOW! We can't wait any longer!

FUTURE WARS INCOMING TRANSMISSIONS

All letters should be addressed to Future Wars c/o Herb Barents, 17187 Wildemere, Detroit MI 48221. Readers should specify if they wish their address published. All responses are from the layout/typesetter, unless otherwise specified.

Dear Mr. Barents,

Enclosed find a check for \$18.00 for a six-issue subscription. I'd appreciate if you could start it with issue #24 if possible.

As a suggestion for those of us who are new to your fanzine, during the course of an article discussing autocannon or new 'Mechs, please review what a "sabot" round does in game terms. At least, this would be helpful until you bring out your "Best of..." compilations, where I'd hope a sabot round would be re-discussed. Will the compilations be part of the subscription or separate issues to be offered at stores only? Instead of answering directly, you could respond in your editorial.

Thanks for your cooperation.

Steven Bach
1324 Williamsburg Drive
Schaumburg, IL 60193

Steve, sometimes space limitations do not allow us to expand on references to older issues. In the future, we'll try harder, but for now, see if you can get a hold of some back issues, or write to the author of the article in question care of Herb.

Also, all readers should be aware that an accurate subscription price can be found on the back of the magazine.

Hi Herb,

I just read #23 of *Future Wars* and liked it immensely. Hopefully my other BattleTech players will pick up on it. We'll stock it on a regular basis. We've had some rather "interesting" variations of 'Mechs designed by my BattleTech players. Some of the names include Gorilla, Scitzo, Piecemaker, and variations of each. I'll get them to think about submitting some of their designs. We also play on a

regular basis-a set up called the "Chinese Fire Drill", better named "Friend or Foe". I've also run a BattleTech game called "the Far Side of the Periphery." It uses a geo-hex set up, a batch of small numbered papers that fit into the hexes to pass on data, and a group of index cards to set up plots of intrigue, treachery, and other role-playing data. The play-testing on the latter has been interesting. Enclosed is a copy of the main story for "the Far Side".

Sincerely,
Bob Roby

Great, Rob. Send any other scenarios along-we'll be doing a regular department for scenarios, so get ready. Thanks for "the Far Side"; you can look for it in upcoming issues.

Mr. Barents:

Thank you for such a prompt reply, it is truly appreciated. A number of other publications I have submitted to have been less than curt about responses.

Enclosed is a short Robotech piece with art, a cover drawing, and a few pages of filler art. Also, I have an idea for the Real 'Mechs issue; "cut-away" drawings of each 'Mech reviewed. You should find drawings of the first two 'Mechs from the 3050 Technical Readout done in this manner. Please inform me as to whether you consider the concept worth pursuing.

Sincerely,
James Greeson
756 Amador Dr.
Chaparral, NM 88021
(505) 824-3201

P.S. i would like to renew my subscription starting with the next issue to be published, Thank you.

Definitely, James. The cut-away pictures are very useful, especially during an

article about BattleMech systems. Your art is a welcome addition to the work found in *Future Wars*. Please continue to send what you can.

Dear Herb,

The first issue of *Future Wars* I bought was #23, and let me say first off that it is an excellent publication. The articles are informative and thought provoking, from both the game and the realistic point of view, and the fiction is very entertaining. One of the features I like most, however, is the new designs of tanks, 'Mechs and weapons for BattleTech. It was therefore with some dismay that I came across the design for the Dark Knight, a variant of the Black Knight. It seems the designer overlooked FASA's rule which limits the placement of armor to two points per point of internal structure (the head excepted). As a result, this 75 ton 'Mech carries 19 tons of armor, the same amount carried by the Atlas!

For the benefit of *Future Wars* readers everywhere, I took the liberty of slightly re-engineering the well thought-out prototype of Mr. Buhl's Dark Knight. By reducing the armor to the legal limit, 14.5 tons. I was able to add two additional double heat sinks, two rear-firing small lasers, and the head-mounted small laser of the original. The resulting 'Mech still carries maximum armor, while also having rear protection and better heat dissipation, and is still jump-capable. I have enclosed a copy of the new statistics and a completed record sheet. I hope this will help alleviate any frustration fellow BattleTech players may have had.

Keep it up!
Andrew C.
2563 Heron Street
Victoria, B.C., Canada
V8R 5Z9

INCOMING TRANSMISSIONS

FUTURE WARS

Andrew, your observational skills are impressive. Although *Future Wars* makes an attempt to remain true to the published rules, it is Herb's belief that an active imagination is more important than strict adherence to the rules. When necessary, though, our staff makes corrections, and readers are free to modify the designs as desired, of course. In the meantime, please send us *your* designs for publication!

Dear Mr. Barents,

Thank you for the reminder about the end of my subscription of *Future Wars*. Please find enclosed a check for \$18.00 to renew my subscription. I have found *Future Wars* to be very useful in supplying new ideas for BattleTech.

Future Wars #22 covered vehicles very well. I have found most players tend to ignore them when one uses a mixed force of 'Mechs and vehicles. A number of players have been confused when I have fielded a force of all hovercrafts against their 'Mechs. Taking advantage of the terrain and the speed of the hovercrafts can lead to some interesting battles. The one problem that I have found is coming up with a number of hovercraft, since Ral Partha makes so few for BattleTech. I have solved the problem by obtaining hovercraft from a couple of other manufacturers. The first is Stan Johansen Miniatures, 128 Barberton Road, Lake Worth, Florida 33467, who has a range of 1/300 scale Star Armour which has a GEV(hovercraft), light and heavy gunships, and GEV supply vehicles.

He also carries a range of resin vehicles from England that has three large GEV vehicles (Recovery, Command, and Cargo). The second source is SIMTAC, Inc., 20 Attawan Road, Niantic, CT 06357, who carry the Scotia Micro Models science fiction range which includes a light hover tank, a hover scout vehicle, and a nice selection

of infantry. The catalogs from both companies are \$2.00 each.

Two articles in issue #23 of *Future Wars* answered some questions I always had about the technology of BattleTech: "Why Range Suck..." and "Looking at the Weapons of BattleTech". A couple of articles I would like to see would be one covering 'Mech armor and the other covering the engineering behind the 'Mechs (How do you top heavy 'Mechs with small feet and thin legs stay upright?).

Yours truly,
Michael A. McKown
1251 Ninth Street, Apt. C
Monterey, CA 93940-3632

Michael, the best way for you to see an article you want is to write it. So please, feel free to submit one to us, as well as new vehicle/'Mech designs. For balance, see "A Matter of Balance" in FW #26.

Hello fellow BattleTech Junkies!

I've known about your magazine for some time now but I was cautious to start buying them due to the price. As you know, BattleTech is an expensive addiction and I am careful in what I purchase. Anyhow, a friend of mine, John Pierson, wrote to you a while ago and I started to get interested in what *Future Wars* had to offer.

I just started running yet another MechWarrior campaign and I made an addition to the initial character make-up. I recently purchased the Mekton II rulebook specifically for my MechWarrior campaign. If you are unfamiliar with Mekton II, it is another roleplaying game similar, but mostly inferior to BattleTech. It provides a semi-detailed history for the player and it gives me, the gamemaster, a lot of initial non-player characters from that person's past. I don't want to get into details, but this addition has brought new life to my campaign. I also changed the old MechWarrior character record sheet and made a new one that is more "space

efficient". I hope that your readers will find my character record sheet an improvement over the old one.

Thanx.
Adam Koziel
28426 Wexford
Warren, MI 48092

We're glad you became interested in *Future Wars*, Adam. Hopefully, we'll be seeing more of your submissions in upcoming issues. Just make sure the copy you send in is clear, crisp, clean, and high-quality, and it'll probably make it.

Dear Herb,

I would like to know from your other readers if they like facing 100+ ton 'Mechs. I don't particularly enjoy it, but I have faced them and I would appreciate any information on new weapons and other ideas from your readers.

The following is a new weapon/coolant unit. This new equipment is only for the Inner Sphere. Bode Industries and Eric Inc. have worked together on this project.

I have been reading your magazine since issue #15, and I really love the way you show the true value of the game.

I wrote to you previously and sent you a 'Mech (The Striker, an 80 ton Clan 'Mech). I also requested information on the 113th Division and the Kins. There was even a self-addressed stamped envelope to mail back the information. What happened? Don't get me wrong: I like your magazine.

Thanks.
Eric N. Johnson
2525 Hillcrest Dr.
Ionia, MI 48846

Occasionally, we do not have the time to personally answer questions. Once in a while, a person will luck out and receive one, but it may not be convenient. Herb has a full-time job, and I have a full-time academic schedule to attend to.

by Pat Hwang

It seems that FASA never makes any poor quality BattleTech supplements. Basically there's nothing to complain about when you buy their products, especially if you're picky about paper quality, artwork, book format and design, typeset, or editing.

Rhonda's Irregulars, a new scenario book published by FASA, is no exception. Containing 72 pages of history, dossier of key personnel, unit organization, and combat scenarios, this book is well worth what you pay. Paper quality is good, and the artwork is aesthetically pleasing (especially the personnel profile pictures). The book format features a soft cover for easy use (as are all of FASA's BattleTech supplements), the typesetting is clear, and the superb editing allows for no ambiguities.

Rhonda's Irregulars is about the eccentric mercenary unit Snord's Irregulars. This book continues where the first scenario book Cranston Snord's Irregulars left off, and has five sections to it: the history of Snord's Irregulars, unit organization and equipment from 3026-3037, and 3037-3051, dossier on key personnel, two new

'Mech designs, and a vehicle, and combat scenarios. Each section will be discussed below.

The history section gives detailed information about what happened to Snord's Irregulars. I won't give out any secrets here, but I guarantee that you will be surprised. This is a must get for history buffs.

The unit organization shows the change involved during the two time periods (3026-3037 and 3037-3051); in 3037, Snord's Irregulars upgraded their equipment to Star League-era level of technology.

This now enables the Irregulars to tangle with the Clans almost on a one-on-one footing, something they do very often.

The dossier on key personnel gives insight to the quirks and peculiarities of each individual, including

the founder of Snord's Irregulars, Cranston Snord. The artwork that accompanies each dossier is outstanding. Also given with each individual dossier are warrior data, equipment usually carried, special notes, and known skills; these are given if you wish to roleplay them as NPCs or PCs for the MechWarrior system.

Two new 'Mechs given in this

book are the 70 ton Excalibur and the 80 ton Spartan. Also given is the Padilla Heavy Artillery Tank (75 tons); if you want to keep your friends on their toes when you are gaming, these two 'Mechs and tank will do it. Artwork with the 'Mechs and the tank are good. In fact, they look better than some of the Clan drawings in the 3050 Technical Readout.

The combat scenario has a game-set up section that gives specific information that is needed to play the scenario. This includes instructions on how to lay out the map sheets and the directions needed to incorporate special terrain features. Each scenario also gives information about defending and attacking forces, victory conditions needed to win, plus any special rules that are not included in the BattleTech Compendium.

This book has something for everyone; it has 'Mech, Aerospace, vehicle, static defense, and infantry combats. What more can you ask for? Of course the main emphasis is still 'Mech combats, but you get more of a mix of different types of combat campaign, Operation Merlin. This campaign is divided into six scenarios: Warrior's Challenge, Grand Melee, Camelot's Gate, Pitched Battle, Men-At-Arms, and Birth of a Legend. The best part of the campaign that I liked was Camelot's Gate. It combined 'Mech Aerospace, infantry, and static defense all into one. This scenario is tricky because it requires you to be extra alert of all your units. If you're not, your opponent can take advantage of your lethargy and really hurt you. Experienced gamers of combined arms will find this part of the campaign delightful.

You may ask, "Is it worth getting?" Definitely. You won't be sorry that you did.

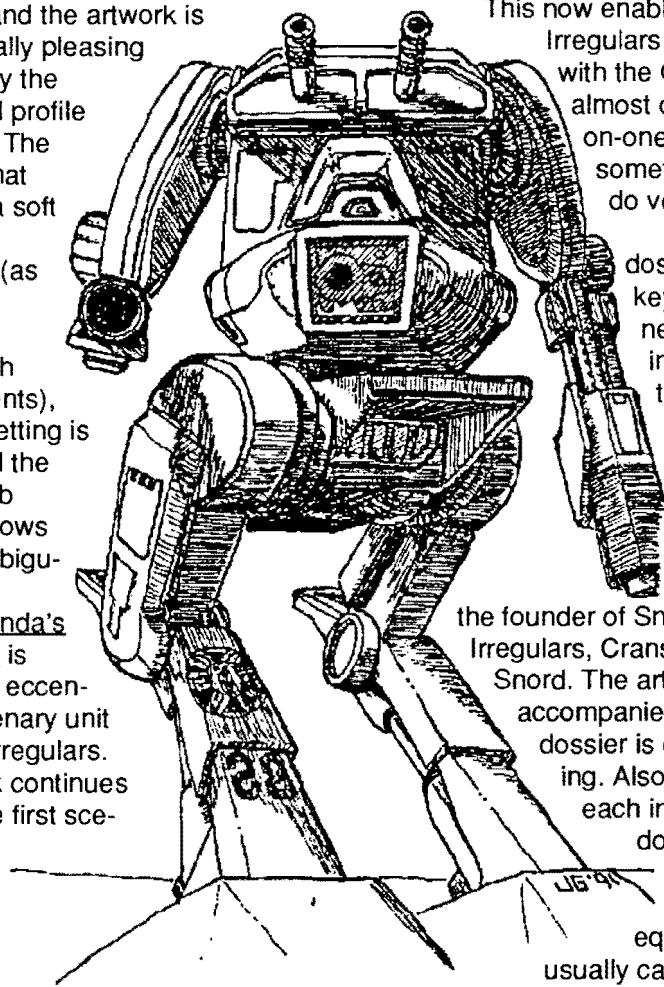

BURYING THE HATCHET

FUTURE WARS

by J. Donald Lail

In my opinion, the new rules on hatchets were ambiguous in one respect: nowhere it is explicitly stated that a 'Mech must carry a hatchet equal to 1/15th of its total weight in order to gain the full damage potential of the weapon. In my mind that was definitely implied. But knowing players as well as I do I know someone will suggest that the size of the axe must be irrelevant. That person will claim, with all sincerity, that since the damage is based on the weight of the 'Mech the size of the axe must not be a significant factor. This is not correct.

The answer is that weight of the 'Mech is not the only operative factor in the case of the hatchet doubling the normal damage for a 'Mech's punch! The damage done by a physical attack is product of mass and velocity in equal measure. An analysis of the damage done by club, kick, and punch attacks shows that the damage done (i.e. force) seemingly varies perfectly with the mass of the 'Mech involved. Apparently the velocity factor is constant for all 'Mechs. In actual fact, however, this is not the case.

Whenever a hatchet (or a club) is added to a 'Mech, the "business end" (head) of the weapon is extended significantly beyond that of the hand(s) which grip it. In swinging to attack, the head of the weapon is traveling at a greater velocity than the hand which holds it. That is why there is greater force (damage) at the point of impact. The only conclusion possible is that the size of the axe is crucial to the amount of damage done. For any cases where an axe of less than the maximum mass is employed, the following equation should suffice:

Mass of hatchet X 1.5 Equals
Extra Damage Due to Hatchet

Simply add the extra damage as given in the formula to the normal punch damage of a mech

and you have its hatchet damage value.

If the head of a club travels at the same velocity as the head of a hatchet, why do they do the same damage? After all, the club has the strength of two arms behind it instead of one. My answer, and please note that this is only my opinion, is that the answer lies in the nature of clubs as described in rules of the game. In every example given, the club is a spur of the moment weapon. It is a girder or a leg or something of the like which is held by the hands of the 'Mech in a very imperfect manner. When the head of the club makes contact with an opponent, it rebounds because the grip is loose. Keep in mind that the hand of a 'Mech has nowhere near the flexibility or the nerve network of the human hand. It cannot hold any club as described well enough to get the bonus damage implied from the greater strength and speed of the two handed attack.

This brings us back to the hatchet. It differs significantly from the clubs described above in three vital respects: it fits the 'Mech hand perfectly, it does not rebound as much, and it is braced to the 'Mech with attachments in the internal structure (crit spaces).

Given this line of reasoning, it might be possible to design two-handed clubs or axes that also fit a 'Mech perfectly and would do four times the damage that its punch normally would do. Contemplate the thought of an *Atlas* swinging an axe for 40 points of damage, in one location, with a weapon which needs no ammo, produces no heat, and which is very simple to operate, repair, or even construct. "Scary idea," you say? "Won't happen," you say? Acceptable you say? Read on, it only gets worse.

I have decided to install triple strength myomers on my *Atlas*. I will now do 80 points of damage with a two-handed hatchet and 40 points

with a one handed one. Therefore, the 40 point damage scenario already exists even without using two hands!

It is very conceivable to me that this (the two-handed fitted hatchet) might overload game balance and I do not encourage its adoption. A similar problem arises if some bright boy or girl decides that two hatchets would make a lovely design. At least this idea spreads its damage to possibly two locations, but I still think it a bad idea.

I've tried to come up with solid, logical arguments against the two-handed hatchet and the two hatchet equipped 'Mech. In the case of the two-handed hatchet, the main problem comes from the fact that two-handed club attacks have always been permitted. It is ludicrous to suggest that a club can be used two-handed but that a hatchet cannot (assuming the handle is of adequate length). It is too late to require two hands on a normal hatchet attack, the rule expressly says only one hand is required. Nor is it reasonable to suggest that the technology doesn't exist to construct such a weapon. I can only come up with one weak, insipid approach; nobody is making one just now and the players don't have the right skills to construct their own.

In the case of the 'Mech with two hatchets my answer is more satisfactory. I would hold that hatchets are more akin to kick attacks rather than punch attacks, and so you only get one of them per round. Thus the second hatchet would be useless.

As always, should any reader wish to comment on any of the analyses or proposals made in this article they may direct their letters to me c/o Gyron Compounds, 14725 Arminta Street, Van Nuys CA, 91402.

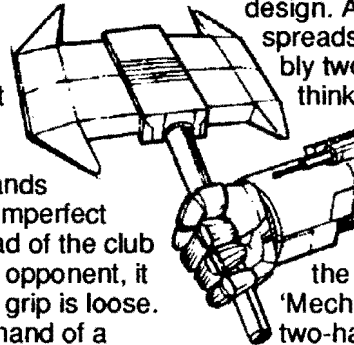

"Well, here it is," Song said blankly.

Song is a potbellied Oriental gunsmith who, though slightly eccentric, is one of the best in his field. He neither "fixes" nor "repairs" small arms. He "re-invents" them. The item Song hands me is a testament to his skill: simplicity married to effectiveness. Four, twentieth century semi-automatic twelve gauge shotguns, mounted to form a semi-circle encompassing the forearm, fire simultaneously at the squeeze of a single trigger. All this is encased in ornate armor with a bayonet and laser-sight thrown in for kicks.

"Lets go out back and see if it likes you".

I followed the old hermit outside to his backyard. There were wrecked vehicles and farm tractors strewn about as if stricken by god. They had all been used as targets for his previous "inventions".

When I first put my arm in this "Thing" (as I began to call it), there was a click and I was amazed to find that something as large and bulky as "Thing" could be ergonomically designed and feel light as a neurohelmet.

"Where's the safety"?

"Tain't nun" he smiles wryly, while scratching his stomach.

"I should've known".

When I was done I was convinced that this was the ultimate in close assault arms. Twenty thousand ComStar bills later, I owned the "Thing" and Jethrow Songs' word that he would not make another and keep "Thing" secret.

I had rented a land skimmer under the name *B. Hunter* (it's so obvious, but nobody has ever figured it out). It's a Harley-Davion and I like sturdy hover-cycles. "Thing" was in the saddlebag. Anyway, this one has some power,

so I test it. By going 200 k.p.h. and spinning 180 degrees, then gunning it to 230 k.p.h., I pulled about two "G"s. Space travel, over time, will de-calcify bones. I wanted to see what these bones of mine could take after so many interstellar warp jumps. The force tore my right hand from the steering bar as I strained against the inertia. My left, being cybernetic simply bent the bar slightly to that side.

It was a good ride that ended at a summer house, also rented. It's a nice little cottage, tucked away on a hillside. With two baths and a garage, it could actually grow on you. The landlady is a very unpleasant person but even Eden had a snake.

I parked the bike in the garage and greeted my one and only friend, Raxx.

Then I went to the kitchen, pulled a fifteen kilo ham out of the refrigerator, nuked it, blessed it, and took it to Raxx, who ate it promptly. Although I am a vegetarian, I don't think these views are shared by a three meter tall bipedal reptile with decimeter long fangs. After dinner I pet and talk to him. Raxx is really gentle with me but he will not let anyone else get close to him without loss of limb. Fortunately, his red eyes and green scale armor deter most people from even considering it. I found him when he was a pup, orphaned by stray missile fire in a 'Mech battle on Rictenheim, over twenty-eight years ago. Now he's fully grown, weighs over one thousand kilos and looks like a dinosaur of old Terra. He has his own place in my DropShip.

Sitting on the roof, I meditate and reach a deep inner peace in the dying light as the sun sets over a distant mountain range. Raxx is below me in the back yard, so I play my flute for him until he lands heavily on the ground and is fast

asleep. It doesn't take long.

Before sleep I shower, recharge my power pack for my cybernetics: left arm and leg, right eye and ear, left lung and heart. Upstairs I set a watermelon and a cantaloupe in bed and pull the sheets over them. Sit in an overstuffed chair with "Thing" beside me, and sleep.

In sleep, dreams of old times take shape. Years ago, when my decision to become a freelance mercenary instead of an officer in the Light Horse seemed like a sound one. I was labeled a cold-hearted, money-hungry killer and hounded from that day on. The Black Widow once met me across the field. She made rash mistakes and lost. Went screaming to ComStar swearing that I murdered her lancemates! Although she lied, the infamy haunts me to this day.

What was that!?!

There is no noise.

No insects chirp.

No wind.

Nothing.

I grab "Thing", insert my arm.

The "click" seems loud enough to echo. Now I'm crouched behind the chair.

Outside, a roar of missiles followed by an explosion. Raxx screams in mortal agony!

A combat boot kicks the bedroom door clean off the hinges. Two three kilo Maxi-grenades land in the the far corner of the room. The landlady might not be pleased with her new window. Luck is with me and the chair absorbed all the shrapnel. The assassin lurches into the doorway. Even after the grenades, I can hear the hydraulics of his WALDO suit as he brings his energy cannon to bear on the bed, but he's too slow. Before he gets the bulky weapon in the room "Thing's" laser sight paints a tiny red dot on his pelvis and blows the

assassin into the room across the hall. I move from the chair to beside the doorway flat against the wall. I guess I wasn't so lucky after all- I can see my left forearm still in the chair!

The other killer assumes a door trap slew his partner and sprays the bed with automatic gunfire from the hall. When there is enough brains and blood to satisfy him, he goes in to make a positive I.D..

Using "Thing" as a club, I knocked the machine gun across the room and placed the bayonet blade at his throat.

He knew he was dead, but he did not crack. Looking me in the eye, he spat.

Thrusting my cybernetic left stump forward onto his armored breastplate, his body was held rigid with electricity until I allowed it to crumple unconscious on the floor.

"It was an honor to battle such a brave warrior. Rest easy".

Looking out the back window, seeing Raxx is lying in a large growing pool of dark liquid, I grimace.

Out-gunned, and out-numbered, it is time to make an exit. I rush to the garage. Dropping "Thing" on the cold concrete floor, I cold start the skimmer. With the whine of a fusion engine at redline, the Harley bursts through the garage door. The exhaust ignites some combustible liquids stored on the shelves.

One unhappy landlady.

The chase is on. The assassins are in a jeep equipped with a short range missile system, no doubt they used it on Raxx. I could easily outrun these bastards, but I want to teach them about cruelty to animals. So I get ahead of them, slow, turn around, gun the engine, ignite the rear mounted flamer and pass back by them at over 275 kph,

keeping the fusion powered flamer aimed at the asphalt directly behind me.

Their driver, suddenly assaulted by flame and smoke of burning tar and asphalt, swerved off the road. Narrowly missing a tree, he was forced to veer back onto the burning road. He was reaching for a gas mask when the fuel tank and remaining missiles detonated. Luckily, this fusion driven hover-cycle isn't affected by fire. I like sturdy bikes.

I rode back to my DropShip, but even with the Harleys' speed, it took almost a standard hour.

Finally, my ship loomed into view. I raced past abandoned security posts and up the service ramp and into the BattleMech facility where I stopped

beside my bright green Marauder. This ship is where I live. I am in command here. There was chaos around me as the ship was preparing for emergency lift off.

"You! What's going on here"? I demanded from a passing technician.

"Unidentified BattleMechs approaching, Sir"!

"Get the medic and tell him Raxx is hurt bad, take an escort and save him! Tell the captain that we're not going any-damn-where and to man battle stations! Got it? Now MOVE"!

My chief tech was with me on the turbo-lift up to the cockpit of my 'Mech. He's about my age but I still have most of my hair.

"How many"?

"Two big ones and one little one. Are you hurt bad"?

"No. What do they want"?

"Fame. How's Raxx"?

"I think he's dead. Help me with this vest".

"I wish I had learned how to drive a 'Mech".

"No you don't, trust me. You've still got two hands".

In minutes I was on the battlefield in a fortified position the engineers had prepared days ago. It is a crude structure made of ferrocrete and steel alloys with tons of earth bulldozed against it and

firing ports on all sides.

Though not as chivalrous as standing boldly on a hilltop blazing away at my foes, there is something sanely practical about the protection of castle-like walls. I wait tensely in my lair.

The ship is where I live, this Marauder is where I will die. I have one of the oldest

'Mechs in the Inner Sphere. This one was actually a prototype of the more popular MAD-3R model, it's slower, but has more staying power than the other model. The on-board computer is a considerable advan-

continued on page XX



continued from
previous page

tage over the trash they are mass-producing today.

I broke in on their comm lines.

"Little one-eyed boys, I don't want to play. Let sleeping dogs lie.

"You make too much noise! Heed me and walk away, else you will surely die!"

Surprised that anyone could disrupt the comm line of his ninety-ton Cyclops, he coldly replied, "Bounty Hunter, you should not be up so late. Old men need their rest. You just retire and let newer, stronger, better hunters take over".

"Well, I won't argue about newer. Son, what you're about to do will cost you your life. All you can think of is the fame of being the one who killed The Bounty Hunter. Don't you know that you just aren't good enough?"

"The Widow Maker never backs down"!

With that oath the Cyclops pilot stepped just in range of my twin arm mounted extended range particle projection cannons. The twin ion streams savagely danced across Widow Makers' torso and left leg. Widow Maker was not swayed by the attack and closed to missile range.

Turning on the exterior speakers, I blast booming maniacal pre-recorded laughter across the battlefield. The effect, hopefully, unnerves the other pilots, unless they are on battle-drug.

This time he was in range of my gauss rifle, too. At mach six, the fifty kilo solid nickel alloy slug slammed into his torso and severely damaged the 'Mechs' gyroscope. The PPCs had a life of their own as they once again ravaged the Cyclops' left leg, burning through the armor and destroying the delicate bearings in its knee actua-

tor. For a moment it stood there, a four story tall machine teetering on the edge of disaster. Then it suddenly opened fire. The gauss slug seemed to accelerate as it came closer to me. Slamming into the center of my torso, the slug damaged the engine's shielding, allowing the tremendous heat to escape. The long range missiles poured from him, but did minor armor damage to my left arm. The majority of the missiles were stray. My other PPC shot him squarely in the head.

Widow Maker fell and there was a tremendous explosion.

Not to be outdone, an Orion stepped into range and a bird-like Jenner, using a myomer acceleration system, closed with me very quickly. I stayed in the protective confines of the bunker- a mistake. The temperature had raised thirty degrees over neutral, and it was going to get hotter.

An alarm in the cockpit flashed a warning of incoming artillery seconds before impact. The earthen bunker offered little protection from the high-explosive blasts that shredded my armor and caused a bunker wall to collapse on my Marauder.

I fell.

With my 'Mech's right leg buried, that Jenner used me for target practice. Its laser fire struck the inner magnetic coils of my gauss rifle. The resulting electromagnetic explosion passed through the circuits of my neurohelmet and caused sparks to shoot from my cybernetic stump. The pain was blinding.

The Orion's autocannon struck my left arm and caused me to miss the Jenner. His missile rack was equipped with special homing guidance systems that would hit any available target. When all twenty missiles flew by me, they targeted the poor Jenner and the

smaller 'Mech's arm fell smoking to the ground.

Pulling on my controls, my machine stood. I had to get away from the bunker. Another barrage would surely have been the end.

The Orion and I exchanged another volley. A shadow passes over me and I quickly step aside and watch the Jenner pilot crash to the ground. He lay there, rolling and thrashing in an attempt to stand.

The Orion pilot was not close enough to use the bulk of his firepower, and because the Jenner was so close to me the Orion's missiles and artillery were useless.

My PPCs tear a gaping hole in the larger 'Mech's torso. His autocannon reply destroys the whole left side of my 'Mech's chest where the gauss rifle was. My Marauder's left arm hung useless at its' side, connected only by cables and a few strands of myomer. The Orion pilot was relentless, and I could not divert any of my remaining firepower from him if I expected to see tomorrow.

I suddenly bring my 'Mech to a lurching halt, pivot and stomp the Jenner's leg into scrap metal before it can regain an erect posture.

The Orion's next autocannon shell misses cleanly and my PPC strikes his missile ammo bin. My next stomp destroys the smaller 'Mech under-foot.

Just like that, it's over. The laughter stops.

When we searched the Cyclops, the pilot, a mister Samuel Colt, had fled.

Three weeks later, Raxx and I were back in space. Now he has a cybernetic arm too. I don't like to get attached to things, but this old dinosaur and I have a lot in common!

P.S. Widow Maker, your days are numbered.

THE HOUSE RULES

FUTURE WARS

by J. Donald Lail

I have been a gamer for some ten years now and the one thing that keeps jumping up and biting me is the "house rule". Most of you have no doubt run into it, but I wonder if you truly realize how subtle and pervasive it can be.

The guys that taught me the game (i.e. BattleTech) had a whole slew of variants, some of them good, some not so hot. Unless you are very careful, variants can color your view of the game, and many of the articles in this 'zine. It took me a year before I sat down and read the rules of a game I had been playing regularly over that time period. Brother, did I get a shock!

House rules actually should fall into three categories: 1. changes to actual written rules; 2. supplemental (new) rules for situations not specifically covered; and 3. house "style".

Changing A Rule (Variants)

One of the tactics Herb used for an article on light 'Mechs some time back was the center jump. As I understood it, the idea was to have the light 'Mechs positioned so that they could jump to the rear of the enemy line, once their own front line and that of the opponents' had closed to short range. Once in place, the enemy would be vulnerable to shots at the weak rear armor. If the enemy possessed no back door defense this was a very good Rules of Warfare tactic.

If however you were playing the optional rule from The Battle-Tech Compendium that allows the arms to flip to the rear, then the tactic was less effective. The opposition could simply flip its arms to the rear and blast the light

'Mechs into premature retirement long before they would normally be able to do serious rear torso damage. I conjecture that this tactic may be left to the medium 'Mechs in the future.

So was this a bad tactic? Absolutely not! The tactic was written based on the official rules of the game. Unless a variant becomes very widespread and almost universally acknowledged it must be ignored when we write about game tactics. I would be willing to bet that since the rear arm flip was introduced in the 2nd edition that an article on light 'Mech tactics written today would not fail to take it into account.

New Rules (Supplemental)

In one particular combat I, as GM, decided I wanted to trick my players into thinking that the two Archers opposing them in the Fire Lance were slow ones that could only move 3/5. My idea was to have my Archers jump into the front line at just the right time moving at a brisker 4/6 clip. The way I accomplished this was somewhat unorthodox.

Simply put, I overloaded the Archers. These 'Mechs went out weighing 75 tons. The extra weight, if I remember correctly was caused by the addition of two additional heat sinks, two medium lasers, and an extra ton of ammo. On about the 13th round of combat the Archers jumped in and, to be blunt, I bloodied a few noses. In this case the players had been enjoying a large advantage, it just wasn't as big as they had thought. Before pressing on there are a couple of things I would like to relate concerning the preceding example. First is that I was trying to surprise my players,

something not easy to do. Second, overloading to carry cargo is an explicit rule. My extrapolation was very mild. Third, my players still think I was a louse for doing it. Fourth, I remain convinced that this is the only logical way to design a Fire Support 'Mech that relies on LRM's.

House "Style"

Mechwarrior vs BattleTech

Finally we come to style, that is, how we play the game. The most basic example of this is; do you follow the rules added in Mechwarrior or not? If you have a +2 advantage on your tactics roll you have an immense advantage when it comes to close in combat. Or perhaps you have a natural gunner in that Archer who will hit with his LRM 20's at long range on a roll of 2 (before modifications). But the most important difference is the attitude the player takes toward his character. In my experience anytime you begin to run more than 1 character you will tend towards being a wargamer who will sacrifice a unit if the gain is worth it. That won't work as often in a RPG where a player has invested months or even years into a character.

I am convinced that FASA intended BattleTech to be a game fought by companies rather than lances. In my opinion, MechWarrior is a lance-oriented game. In point of fact they are two different games, something that it took me a long while to realize. For those who are not familiar with the MechWarrior game here is an example.

Assume the following: 1 GM, 4 Players, each side to have a company of 'Mechs. There are two clear options on how the 8 'Mechs of the players' side that are not

continued on
next page



continued from previous page

primary PC's can be run;

1) The players run 2 extra 'Mechs as either PC's or NPC's. The only thing wrong with this approach is that inevitably most players will sacrifice one PC so that another will survive. NPC's won't even fare that well. Further, if the extra 'Mechs are NPC's, then you may face a situation where most of the work is being done by one side or the other. In such a case how can XP's be fairly divided ?

2) The GM runs the 8 NPC's AND his enemy company. This option is a joke and not even a very funny one at that. From the players' point of view, two-thirds of their side is controlled by the enemy. The poor GM is supposed to be a schitzo and not have his NPC's either control the battle or to favor either side.

No matter which option you take, you've got problems. Furthermore, it must be remembered that the more units you put into play the slower the game. More players will slow things down even more. For these reasons, lance combats seem to work out better.

Because MechWarrior is a lance-oriented game I have noticed a tendency towards a preference for 'Mechs that are general purpose in design. There was little or no room for a specialist type 'Mech such as a Firestarter or an UrbanMech. Why? Because our combats usually involved 3-4 players and their PC's. There was no room for these specialists in the lances of either side. Obviously when you fight on a company rather than a lance basis this need not be the case.

Retreating vs Going Out In A Blaze Of Glory

In most battles the point will come when it would be prudent for

some units to bug out. Whether they will or not is another matter. It may depend on what system is being followed:

1) In MechWarrior or in BattleTech with Skill advancement (for the PC's), the normal setup would be to have a group of players and their PC's versus the GM and whatever temporary characters he has dreamed up for this session. The GM can measure his investment in his force in minutes as opposed to the players who have months and years invested. The GM has an immense advantage in that he doesn't have to care if the 'Mechs and NPC's he is running survive or not. It is my personal opinion that a GM should develop some rules of thumb so that enemy or NPC units that should be retreating or surrendering do so when that is appropriate. In BattleTech when there is no GM anything goes.

2) XP's are another complicating factor. Since the BattleTech skill advancement system awards advancement credit only for destroyed 'Mechs there is going to be a tendency getting a kill at all costs. MechWarrior is a bit more sophisticated in that damage short of destruction, and mission objectives also receive XP's. In the latter case there should not be as great a tendency to play to the death.

Mapboards

Perhaps the most important, pervasive, and overlooked part of style is simply how many map boards are you using? I can tell you it has a profound effect on the game. If you are playing on just one map board, the guy with the AC/20 is going to be top dog. He hasn't taken any damage in bringing his 'Mech into play, he probably has a full load of ammo, and it's going to be damn hard to get out of range. Even if you expand to two boards it's still going to be tough. In my

personal opinion the game should always be played on at least 4 map boards and preferably more. This will give you the room for maneuver and require some attempt at strategy.

It is certain that FASA intended BattleTech/MechWarrior to be played on no more than two mapboards. First, there are only two maps each in the boxed sets. Second, every scenario published to date requires no more than two boards for setup. Third, in the map sets sold separately each map is always paired with another map. The second maps represent either direct continuations of the first map in the pair or are of similar terrain. To my mind that's pretty conclusive. The point is this, designs and tactics that work on a 1 or 2 map setup may be less effective on a bigger layout. Why? Because you're playing a slightly different game than before.

What Options are You leaving Out ?

Usually, BattleTech comes down to a 'Mech vs 'Mech battle. If that's all you play, then it is important that you realize what options you've left out. For instance, let's say you never use infantry, in that case small lasers, machine guns, and flamers are much less useful weapons. If you ignore VTOLs, Artillery, Tanks, Infantry, Navy Units, Fixed Fortifications, Vehicles, Aerospace, and Mines then you are playing a somewhat different game than what was intended and that is, in itself "style".

Well I hope that this discussion has been of use to you. Should any reader wish to comment on any of the analyses or proposals made in this article they may direct their letters to me c/o Gyron Com-pounds, 14725 Arminta St., Van Nuys CA, 91402.

by Philip J. DeLuca

Way of the Clans and Bloodname are the first two books in the "Jade Phoenix" Trilogy, written by Robert Thurston. They serve to flesh out the warrior's life in the Jade Falcon Clan, highlighting the constant "testing" (read: abuse) they go through.

Way of the Clans follows the life of Aidan, of the Mattlov-Pryde line, from his arrival on the Jade Falcon world of Ironhold as part of a sibko to his Trial of Position for Warrior status. The book showcases the constant frustration and anger which seems to drive all Jade Falcon Warriors. The system may produce excellent soldiers, but it stomps on individual spirit in the process. Aidan, of course, soon finds this out.

The major obstacles to his happiness are the Falconers, who introduce themselves by yelling at the sibkin (members of a sibko) NEVER to address the Falconers directly. Immediately after, the Falconers bid amongst themselves to see who can beat (literally) the most sibkin, and proceed to pulp the sibko.

Falconer Joanna, a young Warrior ristar, takes particular pleasure in "riding" Aidan through training. She, under orders from Falconer Commander Ter Roshak, deliberately singles him out for continuous abuse.

Aidan eventually reaches the point where his training is enough to be a Warrior, but again, more obstacles are thrown in his path. How will he succeed in overcoming them? Well, read the book!

Bloodname charts Aidan through his life as a Warrior. Although it may seem that his testing is over, his life as one of the freeborn (a naturally-born person, considered inferior to the artificially

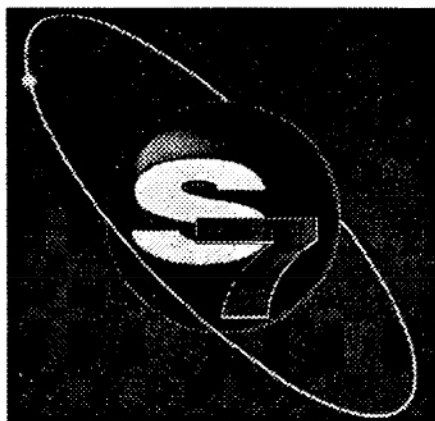

born Warriors) is a constant trial to keep his word and personal honor.

Again, Joanna (now a Star Captain) figures prominently in the segment of life examined here. Serving on the misnamed planet Glory, Aidan draws the worst duties for a Warrior, due to his freeborn status. Coincidentally, Joanna arrives on-planet during a Trial of Possession for the genetic legacy of the garrison commander.

As the name of the book implies, it is now Aidan's turn to assert his right for a Bloodname, the highest honor accorded to any Clan Warrior. Being Bloodnamed guarantees that the Warrior's genes will be carried on to the next generation, helping the Clans for the rest of time. Aidan, of course, needs (personally) to attain that goal.

Although the books are entertaining, and explain much about the Clans and their society, they aren't up to the quality of Mr. Stackpole's work on the "Kerensky's Blood" Trilogy. In essence, these two (and the trilogy's third) fill out more aspects of Clan life, and the differences between the Clans themselves. I would encourage you all to pick these up for some excellent reading.

REVIEW: SOLARIS VII

by Orion Beadling

The Solaris VII boxed set has finally found its way into the hand of one of my close friends and, as a result, into mine. The cover art is beautifully done and honestly portrays the fast-paced, frenzied combat of the Arenas. The set itself includes a player's book, a gamemaster's book, 3 large maps, and 4 sheets of cardboard counters.

The set on a whole draws heavily from Mechwarrior II, both in terms of the role-playing aspects and the arena combat system. The information on the various sites of interest found on Solaris VII provides an interesting feel for the world and its 'Mech game economy. Looking at the sample Solaris encounters will provide the gamemaster with an extensive number of interesting "hooks" for the players (and potential rewards, depending on the players' attitudes toward Mechwarrior wanna-bes).

What I was most impressed with was the Arena combat system. By shifting the scale to 1/4 that of the BattleTech system, some profound changes take place.

First, all ranges for weapons are multiplied by 4 (even MG's, Flamers, and Small Lasers now have a max range of 12 Hexes!!!). With the longest possible line of sight in any arena being 34 hexes, (in Davion Arena), the shorter range weapons start playing a MAJOR role.

Second, since time is also cut to quarter scale, a 'Mech's heat sinks also operate on 1/4 scale. To simulate this, all weapon heats have been quadrupled. Thus, the already important factor of heat is

continued from previous page

now a factor that is NOT to be taken lightly. A strong favoring of the low heat ballistic weapons, and most certainly the Gauss rifle, will be apparent in the more successful Arena 'Mechs. Fortunately, the heat scale has also been multiplied by four, allowing a heat buildup of 120 heat points before causing an automatic shutdown (instead of 30). Keep in mind a single Inner Sphere ER PPC shot will now generate 60 heat points, but the 'Mech will only dissipate it's normal capacity that turn.

Third, with the introduction of weapon delay times there is a strong shift of power from the traditional "big guns", which now only fire once every third or fourth turn, to the smaller weapons, which have delay times of 0 or 1.

So, let's just take a quick look at the effect this will have on weapon selection for Arena 'Mechs. We will take a weapon that has been considered next to useless, the MG, and compare it to the "Top Gun" of recovered technology, the ER PPC.

First, look at range. The longest line of sight in any of the arenas is about 34 hexes, (in most arenas it is in the 20 hex range or even shorter). The MG now has a maximum range of 12 hexes. As long as the weapon is used from near the middle of the arena, everything is in range. The ER PPC now has a maximum range of 92 hexes, (slight OVERKILL), which can easily cover the board.

Second, lets look at how they compare with regards to a standard combat between two 'Mechs at a range of 6 hexes. (I have had the experience that this is one of the more common ranges of encounter in the arenas.) Mech A is armed with 1 ER PPC. Mech B is armed with 1 MG.

Turn 1: 'Mech A fires, builds up 60 heat, and has the potential to do 10 points of damage with no penalty to hit due to range.

'Mech B fires, builds up no heat, and has the potential to do 2 points of damage with a +2 penalty to hit due to range.

Turn 2: 'Mech A can't fire as its ER PPC recharges.

'Mech B fires, builds up no heat, and has the potential to do 2 points of damage with a +2 penalty to hit due to range.

Turn 3: 'Mech A can't fire as its ER PPC recharges.

'Mech B fires, builds up no heat, and has the potential to do 2 points of damage with a +2 penalty to hit due to range.

Turn 4: 'Mech A can't fire as its ER PPC recharges.

'Mech B fires, builds up no heat, and has the potential to do 2 points of damage with a +2 penalty to hit due to range.

Final Score:

ER PPC = 10 points of damage, 60 points of heat

MG= 8 points of damage, 0 points of heat.

Cost:

ER PPC = 7 tons, 3 crits, 15 heat sinks

MG= .5 tons, 1 crit, Ammo(.5 tons, 1 crit)

(total for MG: 1 ton, 2 crits)

As you can see, the MG now packs a LOT more firepower per ton than the ER PPC, as well as having the range to use it.

With the other expansions and modifications to the combat system the Solaris VII Arena Combat System will cause the greatest wave of new 'Mech designs and strategies since the advent of the Clans.

Another area of interest is the

Arena Concept. Each arena has its own write-up in both the player's book (for the "colorful" description) and in the gamemaster book (for the game mechanics). Each map is printed on paper with a similar consistency to that of a magazine cover. It has been my experience that cardboard counters tend to slide over several hexes raising havoc with the duel in progress.

Each arena's combat area tends to be about 1 to 1.5 of the standard BattleTech maps in size. This is where the similarity stops.

Steiner Stadium is very close to the hard-line sports arenas of today, with the small addition of raising and lowering walls. House Liao runs a stadium (The Jungle) containing a rain forest complete with waterfall. House Marik uses a reinforced (and obviously abandoned) factory. House Kurita's Iron Mountain is a series of underground caverns that twist and turn and interconnect. Finally, Davion Arena, the largest and most popular, often simulates an arctic wasteland, but is capable of simulating any conceivable terrain.

I love this set. The background was well developed, the arenas were original, and the combat is beyond anything I had even hoped for.

I do have some disappointments: Solaris VII does NOT give dueling values for Clan weapons. These can be guessed at, but their inclusion would have added much to the set. In the history, they say the Clans are disgusted by the idea of dueling for something so base as "money" (rather than for a "noble" purpose such as honor). While this does explain their lack of appearance in the Solaris VII set, the Arena Combat System would have been ideal for the Clan Trials of Bloodname or any of the other Clan duels.

If you want to feel like you're piloting a 'Mech, GET SOLARIS VII!

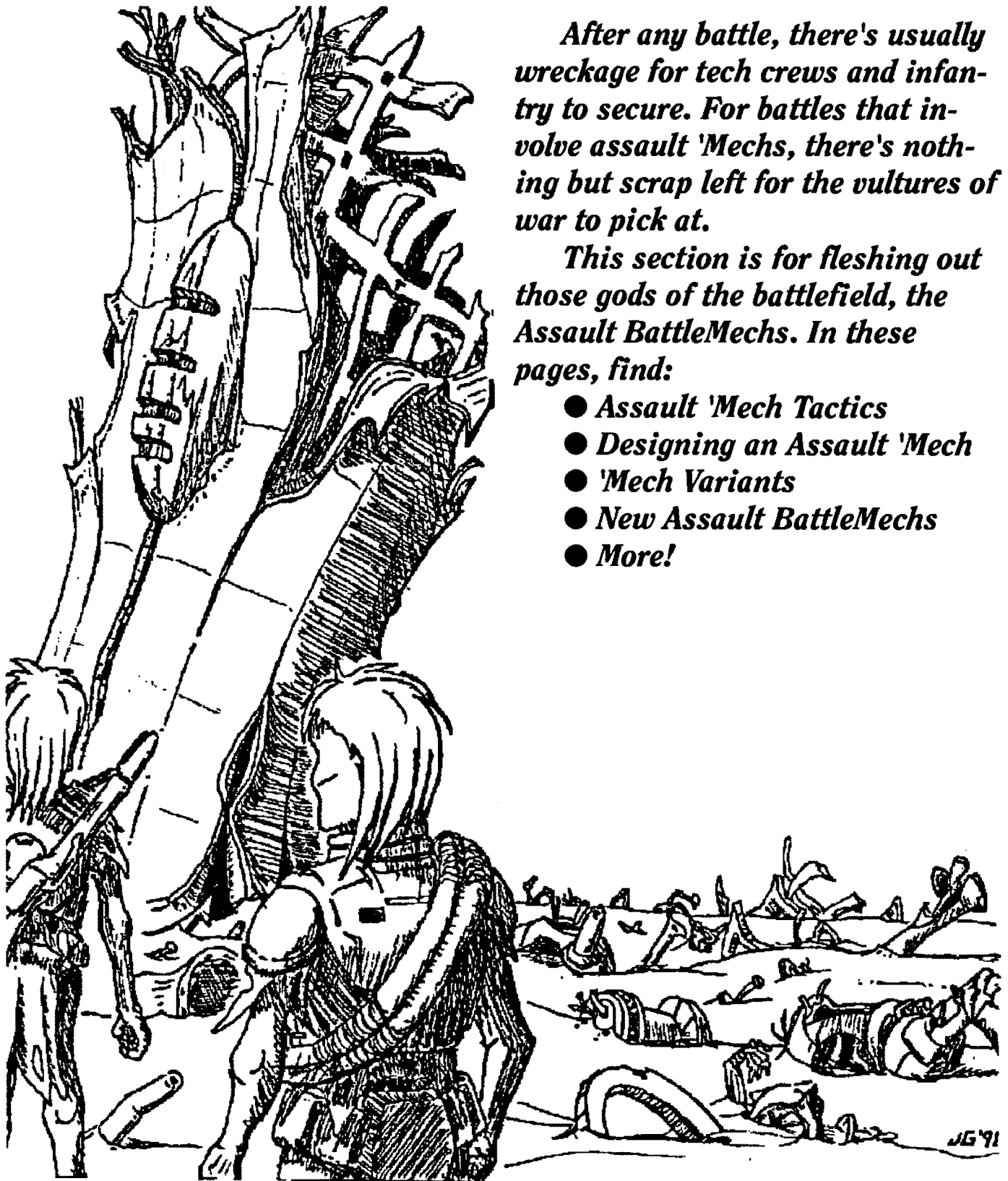

After any battle, there's usually wreckage for tech crews and infantry to secure. For battles that involve assault 'Mechs, there's nothing but scrap left for the vultures of war to pick at.

This section is for fleshing out those gods of the battlefield, the Assault BattleMechs. In these pages, find:

- *Assault 'Mech Tactics*
- *Designing an Assault 'Mech*
- *'Mech Variants*
- *New Assault BattleMechs*
- *More!*

by Herb Barents

Everyone likes to take out the large 'Mechs; you know, the ones between 80 and 100 tons. Curiously, when most people do that, they also seem to disengage their brains at the same time. They feel that having these large 'Mechs is a good excuse just to go out there and have a good ol' time slugging it out at close range.

Fine, but what is and what was the thought behind these behemoths? Were they meant to just go out and kill and take a licking? I don't think so; let's see.

All BattleMechs are hard to replace. Assault 'Mechs, being the toughest and most expensive, are the most difficult to replace. Imagine also the Tech who has the mangled 'Mech to repair. Probably, a mangled assault 'Mech is a nightmare.

But what is an "assault" 'Mech? According to the books, it is a 'Mech that weighs 80 tons or more.

By definition, assault is to attack, to storm an object, taking all the time that is needed to destroy an enemy. Thus, an assault 'Mech should have the ability to defeat an enemy, and that means weapons-large ones, with a lot of destructive potential.

Because of their sheer size, they have huge, weighty engines. No matter what, though, they tend to move slowly, lumberingly, and need all of that bulky armor they seem to all possess. The lack of speed, and the fear that most warriors have of them, makes these "big boys" the most frequent targets

on the field.

But this same power that makes them the most shot at makes them also ideal to break an enemy line. These giants are assigned the tasks of breaking through lines, holding the center, and holding key positions in defensive lines (often against other assaults); to reduce strong points, to take ground and keep it once grabbed; to provide massive support fire as more mobile units move in; and lastly to get in close and carry the day as the last hope.

They are sort of like football linemen-never getting the prize, but without them there'd be no win.



They tend to get the simple, straightforward missions, because they are too slow to maintain a running battle, or pursue. They just sort of lumber up and do their thing.

But what kind of tactics can there be? The way they are brought forward can cover the rest of the forces, and the way they set up fields of fire can be particularly deadly. Good defensive positions make attacking them hideous. Using cover that narrows approaches to the assault 'Mech is a good way to produce mountains of scrap as the enemy charges in.

Flashy play tends to be for the more mobile lights and mediums. Assault 'Mechs, though valuable and rare, are the sledgehammer that smash opponents to pebbles. We're here to do the dirty work.

Talking a closer look at the assault 'Mechs in TR3025, the speed for most is 4-6. One has a 5-8 (the Charger), one a 4-6-4 (The Victor), and three have 3-5. Overall, they have the same movement as heavies do, and so can maneuver as well as the heavy BattleMechs. (The 3025 Charger is a major waste, and could only safely claim to have the power level of a medium.)

The number of different weapon systems range from two to four, with the majority having three, and most others have four. The number of different weapons, however, range from a low of four to a high of ten. In other words, they carry lots of weapons, but not many different kinds of them. For example, an

Awesome has four weapons, 3 PPCs and a small laser, but only two different weapon systems.

Nearly all weapon systems are used: three carry MGs, five carry SRMs, five carry LRMs, six carry Medium Lasers, two have Large Lasers, four have PPCs, three carry small lasers, three have AC-20s, and two have AC-5s.

If a large laser is carried, there tend to be many different weapons as well. If an AC-20 is used, then the 'Mech also has a LRM system to compensate for the close power of the AC. In addition, every one of

them (except the Awesome and the Charger) carry either an SRM or Medium Laser combination, usually two mediums.

Along with all of this weaponry comes a great deal of heat. Assault 'Mechs have between 10 (Charger) and 28 (Awesome), with the majority having around 20. Even so, there's almost no way to avoid having a dangerous heat build-up if all weapons are fired at once. An Awesome must stagger the usage of the three PPCs, and the BattleMaster can't pour on the close-range stuff and fire the PPC.

Armor is where the true difference between the heavies and the assaults comes into play. On average, the assaults have about 60 points more than the heavies (the Charger and Cyclops each have less than many heavies, with 160 points). This translates into about one or two more turns of life than your average heavy, usually enough to be the winner.

Incidentally, there are five 80-tonners, two 85-tonners, and one each of the 90-, 95-, and 100-ton range. The ones at 85 tons have the best balance of speed, firepower, and armor, and in my opinion give the best-'Mech-for-the-tonnage.

The main limitation for the assault 'Mech is its' speed. This somewhat limits their mission choices (not many times for an assault 'Mech pursuit team), but there are some excellent uses for these 'Mechs. Defensively, they are the anchor for your line. Offensively, they are the hammerblow that shatters the enemy, but often with the loss of the hammer. The city seems to be a natural environment for the assault, since close combat and slow movement is required. Leveling a strong point of a defensive structure (or line) is ideal, since the firepower they can

dish out is staggering. Creating a hole in enemy formations for the faster 'Mechs to flood through is good for these monsters to do, but costly again in materiel.

Anchoring the line in key positions is for assault 'Mechs to do. They very often have the best fields of fire and cover, since they need that stuff to be a more difficult target. Other types of defenders get set up around the assaults, to be the more mobile defense "system". In any offensive role, the hope is that you can take your lumps long enough to get in close and finish the enemy. In cities, firing arcs are so limited only one or two targets are visible at a time. This means that not only must you deal out the damage, you have to be able to cope with it too.

Most of what's been discussed takes into account that the assaults are not alone, and are supported by the lights and mediums. Generally, a combined force can exploit the advantages created by the assaults. In addition, the tactics are usually nothing glorious or intricate-down 'n' dirty is the way they were designed.

Positioning the assault BattleMech is the key to the success. On assault. In offensive combat, overlapping fields of fire between assault 'Mechs is extremely valuable. This will allow the massive amount of weaponry between multiple assaults to be concentrated on the same targets, something many Warriors do not find fun. When entering the field and setting up the overlapping "kill zones" obstructive terrain can delay the set-up, and may even cost the battle. Carefully studying the battlefield should clue you in as to where to place your oncoming units.

Terrain needs to be used to the assault 'Mech's advantage at all

times, since they will be getting very little in the way of beneficial movement modifiers. Hills and woods are extremely important, since these can modify targets to hit by +1 or more, which can make a large difference over time. An assault 'Mech has to know when to walk, run, or stand still, considering if the benefits outweigh the modifiers to fire.

When attacking you need to move forward. If you run, reduce your odds at being hit by limiting your opponent's firing arc, making sure he's going to receive as well as he gives. If you can't escape multiple opponent's fields of fire, then walk-give it as good as you take it. Whatever you do, don't stand out in front of the entire defense. They may not be assaults, but combined they can do vicious damage too.

Assault 'Mechs are best used with combined arms, or combined weights. This is a matter of using heavy, medium, and light BattleMechs in conjunction with them. A good mix can truly aid in winning the day. The assault 'Mechs tie the enemy down, and the more mobile units close in and attack, attempting to get to the rear. Your excellent fields of fire mean that if they try to retreat, you'll be pounding them with massive amounts of damage. This means that if you're good, you can "push" them where you want them to go.

By using a "pinpoint" attack, assault 'Mechs and their partners can wipe out a whole unit in a few turns. By picking on this one BattleMech, criticals and internal damage mount up, and soon there's scrap where there was a 'Mech. Again, overlapping fields of fire are important.

On defense, the choice is yours. When do you want to start to fire on the attackers, wait 'til they hit

continued from
previous page

BIGGER MAY NOT BE BETTER, BUT IT SURE IS TOUGHER.

the main lines to concentrate fire or fire when they're way out in front? Do you put the long-range weapons ahead to slow the advance, or behind the lines to support the front?

Especially, keep the ranges of your weapons in mind when setting up the fields of fire. You do not want terrain to block line of sight in mid-range, when most of your weapons can fire accurately.

The attack can be stalled by keeping a good spread of fire over the entire line of the defense. This way, they have to begin to take cover everywhere they go, and the push will stall. A couple of lucky hits in the beginning could stop the entire attack. Overlapping, good fields of fire can bring lead elements of any assault to a halt, and crumble them.

We see that the assault 'mech has a lot of armor, firepower, and low speed. Exploiting the high firepower and armor power is the best way to succeed. Bring to bear as much firepower as possible, using all your tons efficiently, is very important. It can, because of the tons of armor, also take as well as it gives for a while. These 'Mechs will be standing long after most others would have crumbled. This is handy, since they can't get out of the way easily once battle begins; they're committed. They're a good asset, but they have to be positioned right from the start. Making small mistakes will determine the success or failure of your attack or defense. They are that important when you have them, and when you handle them well they will serve you well.

by Philip J. DeLuca

Many times, a new player has asked a simple question: "Why aren't there 'Mechs heavier than 100 tons?"

Many times, a new player has been told a simple answer: "I don't know."

This just doesn't cut it. Except for game balance, there simply is no technological reason why BattleMechs can't come any larger than they do, assuming BattleMechs can even exist. Unfortunately, if you wish to do so, it is up to the creator to come up with a system that allows for the basic design rules to be followed, so that the really heavy ones don't have any advantages other than their incredible masses.

This involves figuring out things like Internal Structure, Jump Jet weight, and absolute maximum weight. Luckily these things each follow a basic pattern that can be extended outward rather simply.

Internal Structure

Internal structure is a piece of cake. The charts in the Battletech Compendium follow a pattern of "X+1" for most tonnages and locations. That is, there's usually only an increase of one internal structure point each time a 'Mech's weight goes up by five tons. Because of the large number of weights involved above 100 tons, simply use this formula:

$$(\text{tonnage} - 100)/5 = Y$$

Then add Y to each of the following, which are the internal structure values for a 100 ton BattleMech: CT=31, R/LT=21, R/LA=17, R/LL=21.

Therefore, the Internal Structure values for a 105 tonner would be equal to $(105-100)/5$, or 1. So

CT=31+1, R/LT=21+1, R/LA=17+1, R/LL=21+1.

If I wanted the Internal Structure for a 210 ton BattleMech, it follows that these are the values: $(210-100)/5=22$. So CT=53, R/LT=43, R/LA=39, R/LL=43.

For balance purposes, I'd say keep the head limited to the standard 3 Internal Structure points.

Maximum Armor Value

This also means that the maximum armor values will need to be calculated. Rather than adding all the Internal Structure values together, then doubling them, and then adding in 9 for the head, try this: Again $(\text{tonnage}-100)/5=Y$. Then $(Y \times 14)+307=\text{Max Armor Value}$.

The Max Armor Value for our 105 ton 'Mech would be $(105-100)/5-1; (1 \times 14) + 307$, or 321.

If I want the Max Armor Value for the 210 tonner discussed above, it would be $(210-100)/5$, or 22; $(22 \times 14) + 307$, or 615 Max Armor Value!! That's almost 38.5 tons of Armor, non-ferro-fibrous.

Jump Jets

Jump Jets are a little tougher to figure out. Since they only provide three values to use to come up with a pattern, it is really an arbitrary decision. The system I would recommend a designer to use is a linear one. This is so that the ultra-heavies can utilize jump jets, but far less efficiently than their smaller brethren. Simply follow this formula for the mass of each jump jet:

$(\text{tonnage}-100)/10 = N$ (All fractions are rounded up). Then $((N+2 \times .5 \text{ tons}) + 2.0 \text{ tons} = \text{tonnage of each jump jet}$.

Therefore, for our little 105 tonner, each jet weighs $[(105-100)/$

'MECHS BEYOND 100 TONS

FUTURE WARS

10 (rounded up) = 1; $((1+2) \times .5 \text{ tons}) = 2.0 \text{ tons} =] 3.5 \text{ tons}$.

For the bigger 210 tonner that's $[(210 - 100)/10 = 21; ((21+2) \times .5 \text{ tons} + 2.0 \text{ tons} = 13.5 \text{ tons}$ for each jump jet.

The system I wouldn't recommend is non-linear, or exponential:

Again, $(\text{tonnage} - 100)/10$ (round up) = N. Then simply $2.0 \text{ N}+1$ tons for each jump jet.

Using this, a 105 tonner would have a four ton jump jet, and the 210 tonner a Really Heavy jet that probably weighs more than most planets.

(Remember that these ultra-heavies still can only have jump jets up to their walk MPs.)

Criticals

Okay, you've got these pretty huge machines all ready to go, but you realize that you have more tonnage than you can possibly utilize with only 47 critical spaces available (8 for each arm, 2 for each leg, 2 for the center torso, 12 for each torso, and 1 for the head). The solution to this is perhaps the most deviant from the published rules that I will invent. For the truly hardcore rules lawyers, I'd say that you shouldn't even bother reading this article if you aren't going to use the extended criticals.

When the new critical capacities are calculated, simply pretend that you have another table for critical locations, if you have to use more than the sheets provide for each location.

For the new Torso (each) and Arm capacities, simply add 1 critical for every 15-tons over 100, rounding all fractions up. The 105-tonner has one extra critical in each torso and arm location, for 5 extra criticals, and the 210-tonner has eight extra criticals in each arm $((210-100)/15 = 7.33)$, eight in each torso, for a total of 40 extra criticals.

For new Leg capacities, simply add 1 critical for every 30 tons over 100, rounding fractions up. Thus, the 105-tonner gets 1 extra critical in each leg, and the 210-tonner gets 4 extra criticals in each leg.

For new Head capacities, simply add 1 critical for every 100 tons above 100, rounding all fractions up. The 105-tonner gets 1 extra critical, and the 210-tonner gets 2 extra criticals.

Engines and Maximum 'Mech Tonnage

For speed and ease of play, use only the engine ratings provided in the published materials by FASA, with one engine per 'Mech. (Of course, if you're feeling particularly stupid, you can always use ICE in place of fusion, don't forget.)

This obviously places a limitation on the tonnage of any 'Mech beyond 100: 400 tons, since your minimum walk MP is 1 (rating of 1×400). Sure, that means that no 'Mech over 100 tons can walk faster than 3, but that's the trade-off for the raw firepower.

For campaign purposes I'd say to use these EXTREMELY sparingly, unless you wish to incorporate them as a new form of technological advance. As such, lost Star League or experimental Clan bases probably also incorporate some of the more advanced equipment in them too, and may not be appropriate for maintaining game balance. Just imagine your players with a 400-ton OmniMech (Internal Structure - CT=91, R/LT=81, R/LA 77, R/LL 81; Max Armor Value of 1,147 (over 71.5 tons of armor); a move of 1/2//1 (18 tons for that Jump jet!); and 151 Critical spaces to use almost 300 tons of weight remaining)

For straight BattleTech purposes, have fun!

**SUBSCRIBE
TO**

**FUTURE
WARS**

**BE THE FIRST
TO USE**

**CUTTING EDGE
'MECH DESIGNS,
SCENARIOS,
TACTICS,
AND NEW
WEAPONS.**

**SEND \$19
FOR A SIX-ISSUE
SUBSCRIPTION
TODAY TO
HERB BARENTS
17187 WILDEMERE
DETROIT, MI 48221**

by Herb Barents

The assault 'Mech is the heavy bruiser of the BattleTech world. It is the 'Mech with the armor and weapons to take care of anything and anybody (the Monsters of the Midway, cruisin' for a bruisin'...). But when drawing up plans to build one, what should you be thinking about to create a Really Good design? After all, there are good and bad designs. Will it be a defensive platform, an attack 'Mech, a close-in fighter, or long-range attack-support?

Once that is decided, there are a few choices to be made for the assault 'Mech: how fast will it move, how much weaponry will it carry, and how much armor will it need? For the "best" 'Mech, you will probably need to balance out these choices. If you have a specialty 'Mech in mind, then you can likely get away with having things out of balance.

The first thing you need to look at is the speed of the 'Mech. When considering this, the mass of the engine is important. If you need a 100-tonner with four MPs, the engine's mass will be 52.5 tons (note that an XL engine will be half that mass). That's a lot to sacrifice for that speed. Added to the constants of the gyro, cockpit, and the internal structure, these combine to about 70 percent of the total mass. With maximum armor (20 percent more), that leaves about 10 tons for all the 'Mech's weaponry and heat sinks! An 85-tonner with the same speed will use up (engine plus gyro, cockpit, and internal structure) only about half it's available tonnage,

much better than the 100-ton BattleMech at the same speed (please note that by using XL technology, these percentages become radically different).

The next big thing to look at is the armor of the 'Mech. Luckily, this is pretty cut-and-dried. You need 80% to 100% of the maximum armor tonnage allowed to compete with the book 'Mechs. The book 'Mechs that fit into those percent-

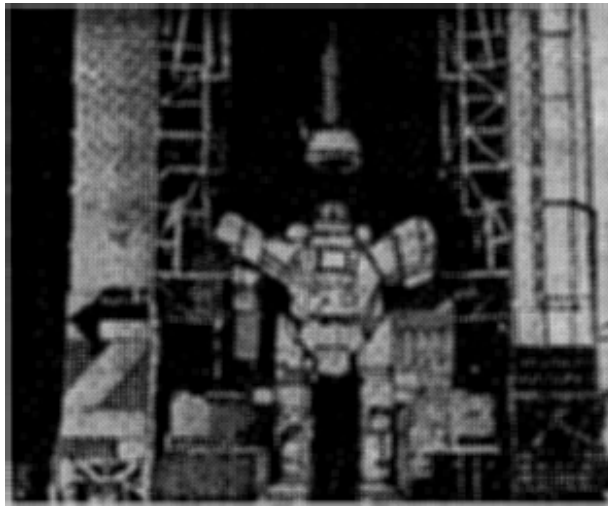

ages are the Awesome 94%, Goliath 97%, BattleMaster 85%, and Atlas 95%. Some come close, like the Banshee and Stalker with 79%. Others like the Victor and Zeus have 72%, the Charger has 62%, and the Cyclops only has 59%.

When designing your 'Mech, remember that having enough armor will allow you to have the staying power an assault 'Mech needs. These armor figures equate to about 20 percent of a 'Mech's total mass, so be sure to keep at least 16 percent available just for decent armor protection.

The next thing, which truly defines the 'Mech's "mission", is outfitting the design with weapons.

A general design will require a good mix, and it comes down to

choosing the type. For long range, will the choice be an AutoCannon, LRM, or Energy Weapon? AutoCannons (and the advanced Gauss Rifle) are heavy, bulky, and need ammo, but are low in heat. LRM's are medium weight bulkiness, and heat, but need ammo. Energy weapons are light, low in criticals, but high in heat. In addition, the AutoCannons and Energy weapons punch one area, while the LRM's scatter the damage. Likely, you'll only have room and tonnage for one or two long-range weapons, so choose them to complement your close weaponry. I prefer the AC-10, because of the (no minimum) range, heat, and damage involved. The best close-range weapons are the medium laser and the SRM-4, for weight-tonnage-damage, as is the (long-range) large laser.

Ultimately, the designer has to decide. Make sure to have a concept/"mission" in mind, and then tailor your weaponry complement to that role.

Jumping is important also, since sometimes the best way to get out of a tight spot is to jump away. But, is it worth putting 6 percent to 12 percent of the mass of the 'Mech into? Jumping one or two is next to useless, since the benefits only start to come in when there are three jump MP available. If you think Death From Above is a good reason, then think again. The potential damage is much greater for the weaponry you carry, and the DFA is a flashy waste for an Assault 'Mech.

Assault 'Mechs are not difficult to make, but most times it will take a few redesigns before you get it right. Once the design work is done, and you keep within the guidelines of the 'Mech, it should be an assault BattleMech that will stand up in battle time and again.

by Herb Barents

The BattleMaster was one of the first large 'Mechs and one of the most successful. The 'Mech is very well-liked and has a lot going for it. Just about the only complaint is that it lacks many long-range weapons.

The it has a PPC that is self-contained, meaning that it is not built into the 'Mech, so it can be dropped. The Mech can also switch the PPC between hands and still fire it.

It has very big and sturdy legs, very strong legs. Also because of the arrangement of the smaller weapons, it can save on heat when they are fired together. And it has a targeting system that allows for hits that are better than normal.

What does all this mean in game terms? The BattleMaster can drop the PPC. It can switch hands, but at a plus one to hit when fired. Also if it takes an arm hit in which the PPC is being carried, a piloting skill roll is made to see if the PPC is dropped. If it is being held in an arm which takes internal damage it will be a piloting skill roll with a +2 penalty to hold onto the PPC. Because of the legs, you are a -2 bonus to all piloting skill rolls, and a kick does

19 points of damage. The targeting system allows all medium lasers in the forward arc to hit at once with the same die roll (hits like a SRM 4) doing only 10 heat not 12. The SRM 6 can also be fired at the same time at the target (using the LRM 10 table) for a total of only 12 heat when firing all items. The hit pattern is SRM6-Laser-SRM6-Laser-SRM6-Laser-SRM6-SRM6.

The Stalker is an egg on legs. It is a very different design from the "standard". There are some very bad points and some very good points as well. The torsos are rounded to ward off damage. Lack of arms, the center of gravity, and the torso joiner on it means it can get in trouble easily.

In game terms this means it is at a +1 penalty to all piloting skill rolls. No physical attacks of any kind are allowed, and no arm extensions either.

The torso cannot twist. Head hits from the rear become

rear CT hits. All punches and autocannon hits in one of the torsos from the front or side are at -2 damage due to the sloped hull. Lasers hitting in the same Torso areas suffer a -1 damage reduction. This monster can take a lot of damage; it is like increasing the armor by 10-20% in the torsos.

The Cyclops is one of the ugliest 'Mechs that was ever made.

It seems to have been designed in a hurry and rushed out onto the market and into battle before they had gotten all of the bugs out. The legs are too thin and it is somewhat unstable, and the large AC-20 is placed in an area that reduces the performance of the Mech. They did put in a lot of gear for targeting and tracking, and with the missiles it is one of the best systems in the Inner Sphere, though very fragile. The lasers were placed too far apart on the arms, which causes some concern when punching.

In game terms this all means the following: -1 to all piloting skill rolls, and no right torso twist. No head hit from the rear until the Rear Center armor is gone. Punches do 7 points of damage, kicks only 15 points. A bonus of -1 to gunnery when firing missiles, and a +1 to the roll for the number to hit until the first head hit, then this bonus is lost. No charges are allowed. The AC 20 has a right-side arc of fire. This means that the forward center hex, the forward right hex and the right side hex form the firing arc. When it punches, it must check the weapons malfunction chart for the medium lasers (or roll for criticals which would automatically take out the lasers only).

The Victor is a very clean 'Mech with a good design team behind it. They cover many areas well, making sure all things fit together before putting this Mech into production. This 'Mech is not the most mobile 'Mech in the Inner Sphere at all. In fact, it is very tough to handle at times, but it is a good solid design. It has a helmet, so no rear head hits until rear CT Armor is gone. No torso twist is allowed, and it can punch only with left arm, no arm extension allowed. It is +1 penalty to all piloting rolls, and can fire AC-20 into target before it hits with a death from above.

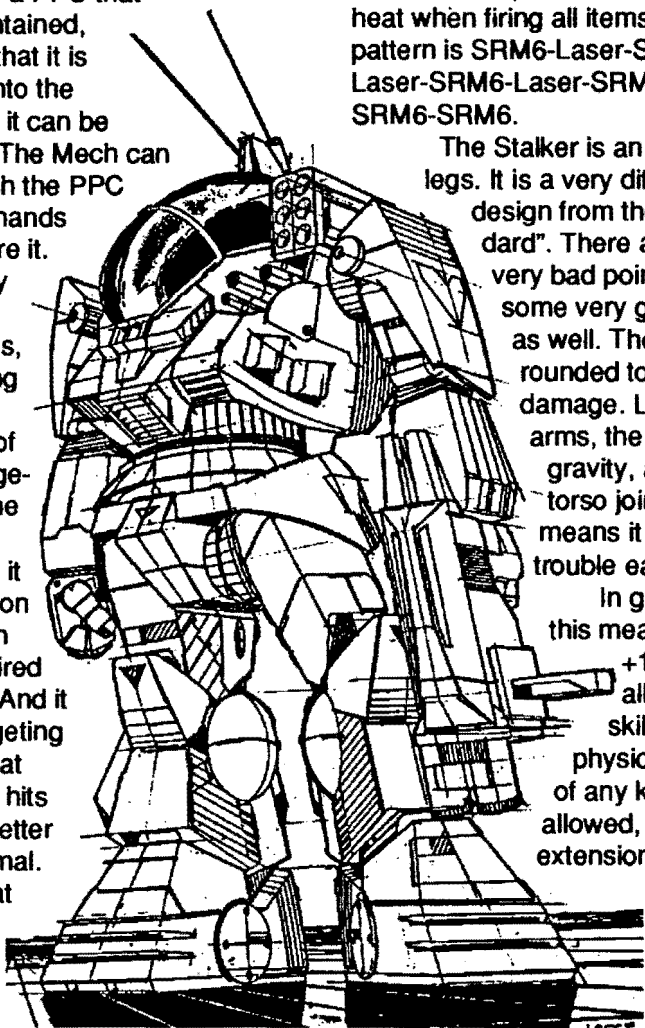

WHY HAVEN'T YOU SUBMITTED YET?

FUTURE WARS IS LOOKING FOR PEOPLE TO WRITE REGULAR COLUMNS ON SILENT DEATH, RENEGADE LEGION, PLUS OTHER SCI-FI RPGs AND WARGAMES.

by Philip J. DeLuca

Continuing my articles about BattleMech modifications, I wrote this one specially for the Assault 'Mech issue. Reiterating, most of us held or hold the Original 'Mechs, bookmechs, as the best 'Mechs that could be made. Then, after designing our own, or seeing others' designs, we realized that there can be better BattleMechs. Even my 13-year old nephew Adam has seen this.

Since this is the Assault 'Mech issue of *Future Wars*, I figured this article was appropriate. I've taken the time to list the Assault 'Mechs (those 80 tons or greater) published (no Clan and no Star League) in order by tonnage along with modifications I recommend. This way, you can keep your opponents off-guard, especially those who may have gotten used to your modifications.

Awesome: Pretty good as it is, though hot. Drop the S Laser; add 8 armor. If you modify it more, why use an Awesome?

Charger: Very Bad 'Mech. Pick again, or downgrade the engine; if you do, it's a different 'Mech altogether anyway.

I'd rather have a ShadowHawk, which shows how bad the Charger is.

Goliath: Pretty bad, again. Drop the two LRM-10's, MG's and MG ammo; add four LRM-5's, keep the ammo, and add four M Lasers.

Victor: Possibly the best 80-tonner. Drop the SRM-4 and ammo; add 32 armor, 1 M Laser.

Zeus: Drop the AC-5 and ammo; add a PPC, 2 HS; move the rear M Las. These Lyrans can sure make a

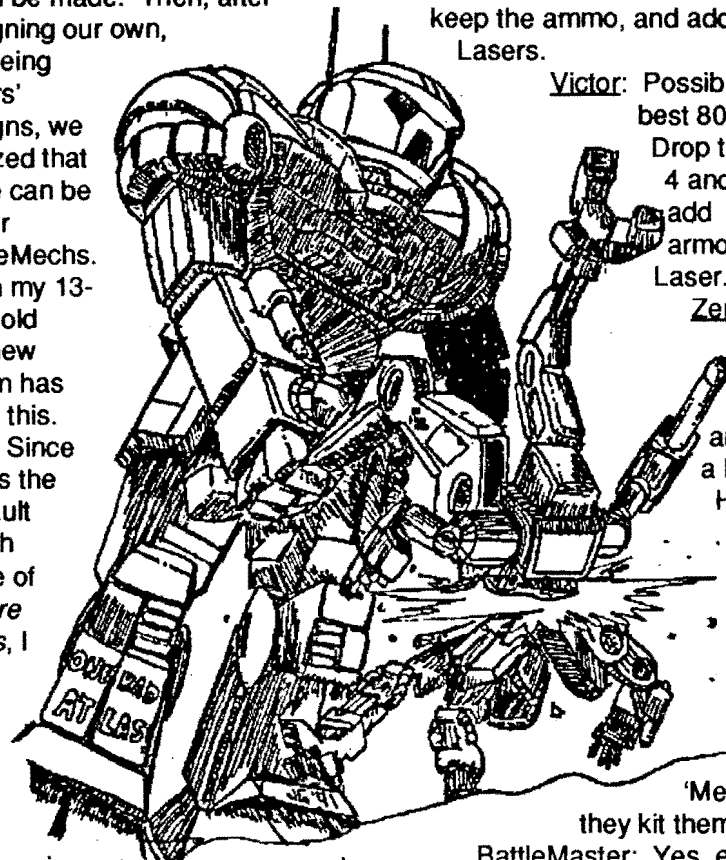

'Mech after they kit them.

BattleMaster: Yes, even the Lord of the Battlefield (hah!) can use some changing: drop MG's and ammo; add 2 HS; move rear M Lasers.

Stalker: Drop both LRM-10's; add four LRM-5's, 2 HS. Better than the BattleMaster in most ways.

Cyclops: Drop the LRM-10; add two LRM-5's, 1 HS.

Banshee: Your best bet is to lower the engine rating. If not, drop the AC-5, ammo, and S Laser; add 5 M Lasers, an SRM-6 and 15 ammo, and add 8 armor.

Atlas: Just move the M Lasers to the front, or design your own. Not bad as it stands.

by Dave Lovelock

Type: Archer II

Mass: 85 tons

Chassis: Earthwerk Archer II Plus

Power Plant: Strand 255

Cruising Speed: 33.4 kph

Maximum Speed: 56.2 kph

Armor: Maximillion 1000

Armament:

2 Arrow IV missile system

1 Magna MIV Large Laser

1 Martell Medium Pulse Laser

1 C3 Master System

Manufacturer:

Earthwerks Incorporated

Primary Factory: Calloway IV

Communications System:

Neil 10,000

Targeting and Tracking System:

RCA Instratrac Mark XIII

Cost: 11,370,860 (C-Bills)

Overview

Since the commencement of the Archer project, the military had a need for a 'Mech with excellent long range capabilities and enough weapons and armor to get it to the scene in one piece. The original Archer fulfilled this task adequately, but the 'Mech was clumsy; MechWarriors were able to "read" Archer pilots and could outmaneuver them without too much trouble. Revived lostech has made the Archer popular among the forward lines once again. This new design (the "II" series) showed so much promise that enemies have already given it a namesake, the Havoc. Officially the Archer II, the name Havoc seems appropriate for the 'Mech.

Capabilities

The ARC-6L Archer II carries a massive load of weapons, armor, and ammunition, and is a happy addition to any lance or company.

The two Arrow IV missile launchers are, like the old LRM-20s, in the torsos, in large "boxes" between the arms and the center torsos. The 'Mech's speed is sufficient for its class. The Strand 255 powerplant lives up to the Strand name of quality. A small drop in power output is seen when the 'Mech is continuously driven uphill. Fortunately, this is not noticeable under battlefield conditions.

The Arrow IV missile system, located in each torso, is unique in that the right torso holds 15 homing missiles and the left torso holds 15 saturation missiles. This design

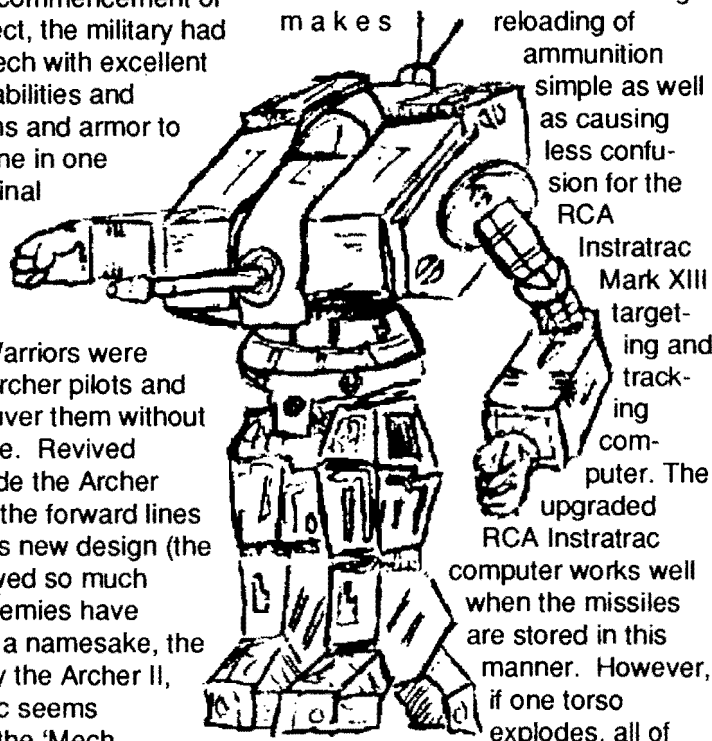

that particular ammo is destroyed.

The Arrow IV system is astoundingly accurate when used with a forward observer like a Raven. A typical unit would have a

lance of three Archer IIs and a Raven. The lance would position itself in such a way so as to hide against recon and air surveillance. The Raven would move to the target area and use its TAG or its C3 computer to acquire a target, and the information would be relayed to the Archer IIs. After the Archer IIs' computer had processed the information, it gets sent to a television guided missile. The missile then can "look" for its target because it has a "picture" of the target, delivering damage equal to the largest 'Mech-portable system.

In case the 'Mech's enemy gets within range to do damage to the Archer II, the 'Mech carries a large laser and a medium pulse laser. The large laser is positioned in such a way that if damage gets through to the internal structure of the torso, the large laser gets damaged before the more important engine (optionally, this means in game terms, the large laser automatically takes the criticals). Although this increases the short-term life of the 'Mech, some MechWarriors oppose the idea, saying it makes the 'Mech useless at close range.

The 'Mech also carries the newly designed C3 master computer. The C3 helps to make use of the information from forward observing units, as well as linking distant lance mates together.

Battle History

At present, the Archer II has no battle history. It is hoped that the Archer II will aid the Inner Sphere's attempt to defend against the Clans.

by Gregory W. Detwiler

During the reconstruction period following the First Succession War, the first *Awesome Jagers* were built more or less simultaneously by Houses Marik and Liao. Along with House Davion, Liao had a sizable percentage of the *JagerMechs* still in existence. However, this model 'Mech had very light armor for its size, which made it vulnerable to both ground units and aircraft. Slapping more armor on *JagerMechs* was one solution, but one could go only so far in this. At the same time, a fair number of damaged Marik *Awesomes* had fallen into Capellan hands during the First Succession War. Someone in the Capellan High Command had a brilliant idea: rearm the damaged *Awesomes* with virtually all of the *JagerMech's* weapons and its targeting system, thereby creating a superior 'Mech for fire support and anti-aircraft work.

Meanwhile, House Marik was having problems with repairing its *Awesomes*. Because of the severe shortage of PPC production facilities in the Free Worlds League, *Awesomes* with damaged main armament took a long time to get replacement weapons. There was also a pressing need for specialized anti-aircraft 'Mechs, and House Marik's *Rifleman* production facilities were not extensive enough to fill all needs. Houses Davion and Liao had the majority of the *JagerMechs* remaining in the Inner Sphere, and only the Federated Suns actually had a *JagerMech* assembly line still in operation. Making a virtue of necessity, the Marik High Command began to produce its own variant of the *Awesome Jager*. To this day, there is considerable argument among historians (particularly in Liao and Marik space) over who actually created the first *Awesome Jager*.

Technical Aspects:

Basically, the *Awesome Jager* is nothing but an *Awesome* with the autocannons, medium lasers, and targeting system of a *JagerMech*. Naturally, this means that the *Awesome's* left arm had to be removed, but the pairs of Mydron Autocannons (two Model C Mediums and two Model D Lights) give the 'Mech excellent hitting power at only a portion of the heat produced by the old PPCs, causing two heat sinks to be removed. The *Awesome Jager* also has a Magna Mk. II Medium Laser on each side of its torso, in the mountings where two PPCs used to be. This gives the 'Mech better close-in firepower than the old *Awesome* had, though it is still slight for an assault 'Mech. The only weapon system remaining from the old *Awesome's* arsenal is the head mounted Diverse Optics Type 10 small laser. All this firepower is directed by the *JagerMech's* Garret D2j targeting system.

Naturally, there are some problems with this 'Mech. The new weapons systems and their attendant ammunition supply weigh far more than the *Awesome's* old armament did. Since the whole idea behind the *Awesome Jager*, at least in Liao space, was to create a massively protected AA and support 'Mech, none of the *Awesome's* armor could be sacrificed. Therefore, the new 'Mech weighs about 10 tons more than the original, with a corresponding reduction in speed. In point of fact, the *Awesome Jager* is just about the slowest 'Mech there is, tied only with the *UrbanMech* for this dubious honor. Unlike the old PPCs, the main armament can run out of ammunition, though this problem is faced whenever energy weapons are replaced with cannons or missile launchers. Between its slow speed and close ties to supply lines, the

Awesome Jager is only fit to do what it was designed to do: provide AA protection and support fire for vital battlefield positions and rear-area installations. Its thick armor gives it the ability to survive a stand-up firefight far better than the *Rifleman* or *JagerMech* ever could, and has provided enemy land and air forces with many a nasty surprise.

Battle History

Awesome Jagers have seen combat in both Marik and Liao space from the Second Succession War onward, taking part in such notable engagements as the defense of Tikonov against the great Davion assaults against this vital Capellan industrial planet. The Second Succession War saw the first of many MechWarrior "aces" to use this 'Mech. Captain Konstantin Budyenny, during the defense of Tikonov in 2832, personally shot down four *Corsairs* and three *Stukas* while performing anti-aircraft duty, and also polished off three *Enforcers*, almost as a sideshow to his main duty of AA defense.

Perhaps the *Awesome Jager's* finest hour came during the joint Andurien-Canopien invasion of the Capellan Confederation shortly after the Fourth Succession War. A number of these 'Mechs were in the ranks of Warrior House Kamata, and saw extensive action against the Andurien assaults on the world of Betelgeuse. The saga of Captain Robert Duncan, who had transferred to House Kamata from the Northwind Highlanders shortly before their defection, was probably the greatest.

Captain Duncan's lance was defending a position under assault by the 3rd. Defenders of Andurien. A canny tactician, he had carefully gauged the distances at various points on the battlefield, gaining a valuable edge in targeting speed.

Type: JM6/AWS AwesomeJager

Mass: 90 tons

Chassis: Technicon Type G

Power Plant: 270 Pitban

Cruising Speed: 31.6 kph

Maximum Speed: 52.4 kph

Jump Jets: None

Armor: Durallex Heavy Special

Armament:

2 Mydron Model C AC

2 Mydron Model D AC

2 Magna Mk. II Lasers

1 Diverse Optics Type 10
Small Laser

Manufacturer: None

Communications System:

Garrett T19-G

Targeting & Tracking System:

Garrett D2j

When a pair of *Thunderbolts* lumbered into his field of fire, his first shots destroyed the shouldermounted LRM launchers, eliminating their long-range fire capability. The enemy MechWarriors then urged their machines into a shambling run so they could close and use their SRMs and lasers. They obviously thought they were facing a mere *JagerMech*, counting on their superior armor to survive the charge long enough to do lethal damage. The old *Awesome's* armor stood the exchange of fire better, however, and soon both Andurien pilots were forced to punch out of their badly shot-up 'Mechs. Using his lasers and what was left of his autocannon ammo, Duncan then ambushed a *Cicada* that wandered in to see why the attack had stalled at this part of the front. The recon pilot died before he could make a report, and by the time new attacks began, Duncan's 'Mech had restocked its ammo bins.

Duncan's next two opponents were an *Archer* and a *Crusader*, both relying on missile fire to wear down their opponent. Since the missile targeting systems of the

Star League Era were no longer in use, the *Awesome Jager's* autocannons were far more accurate in long-range fire, and both enemy 'Mechs were destroyed in their favored style of combat. Two *Rifleman* came next, striding boldly past their shattered predecessors. By this time, the Andurien troops had a fairly good idea of what they were up against, and the *Rifleman* pilots were obviously hoping to catch their opponent when he was out of ammunition. Their own ammo was almost gone, but they still had their twin large lasers against the *Awesome Jager's* mediums. Duncan shattered the cockpit of the first *Rifleman* with the last of his autocannon ammo, killing the pilot, then managed to take out the second 'Mech with his medium lasers. Although the *Rifleman's* large lasers did more damage, the 'Mech was lightly armored for a heavy machine, and the *Awesome Jager's* vastly superior protection enabled it to survive the mutual pounding the two 'Mechs inflicted on each other. By the end of that day's fighting, the *Awesome Jager* was barely operational, and had to be removed to the rear for extensive repairs.

Duncan's 'Mech was returning to the front just in time to stop an Andurien breakthrough. A full lance of *Orion V-As* was advancing in Duncan's sector, and at the moment, his was the only 'Mech available to face them. This model of the *Orion* sacrificed the LRMs for more SRMs, making it a specialist in close-in fighting. Duncan's *Awesome Jager* blasted them to scrap with its autocannons, using the twin medium lasers to finish the job. Duncan had single-handedly saved the day, and even survived to add a *BattleMaster* to his score during the final Liao counterattacks.

Variants:

Both Liao and Marik Techs have replaced the *Awesome Jager's* medium lasers with large lasers in a number of models. While boosting the 'Mech's close-in combat capabilities, it also increases heat buildup. Still, this *Awesome Jager 2* has seen some combat. Of the original version, Davion and Steiner forces have captured a few machines from their Liao and Marik enemies respectively. House Kurita has no 'Mechs of this type.

Notable 'Mechs and MechWarriors:

Captain Konstantin Budyenny
The first *Awesome Jager* "ace", Captain Budyenny won his glory with the Tikonov Defense Force, during the first year of House Davion's three-years-running attacks on that major industrial world. By the end of 2834, the captain had been promoted to major, and had racked up an impressive score of 12 aerospace fighters and 15 BattleMechs. A short but powerfully-built man with black hair, he claimed descent from one of the earliest families of settlers to land on Tikonov.

Captain Robert Duncan
One of the great individual heroes of the defense of Betelgeuse, Captain Duncan's handsome face was soon plastered all over what was left of the Confederation on military recruiting posters, particularly for the Warrior Houses. A clean-shaven man with blond hair, Bob Duncan is slender and of medium height. His "escape" (really a transfer) from the Northwind Highlanders to House Kamata right before the Fourth Succession War broke out is almost as famous as his combat exploits. Indeed, his "escape" provided the title of his autobiography, [The Last Liao Highlander](#) (Capellan Institute Press, 3038).

by Erik Eid

In days gone by, the Ost series of Mechs were extremely popular on the battlefield. Even so, the parent company, Ostmann Industries, was facing bankruptcy; most of their 'Mechs met new owners through capture and middle-man sales, which ate through their profits. To remedy this, Ostmann Industries created the OstLord, an assault 'Mech in the typical Ost tradition.

The OstLord is a sleeker version of the familiar bulb-and pod design seen on other Osts. It is also fast, given its design weight of 80-tons. As usual with Ost 'Mechs, the OstLord is armed with the high-quality Totshlagen and Fuerstrum designs. Its full weapon array consist of two LRM-15s, one large laser, and two medium lasers. The two medium lasers are placed on the head and the rear left torso, protecting the OstLord from flank attacks. Also standard of the Ost series is the Riese armor, with the OstLord carrying 14.5 tons of it.

Two problems prevented the OstLord from reaching full battle popularity. The first problem was the flood of other Osts throughout the regiments in the Inner Sphere. With all the Ostscouts, Ostrocs, and Ostsols running around, the OstLord had little chance to break into the main forces; regimental commanders chose other Mechs because they had too many Osts to begin with. The second and most serious problem was its lack of originality. The OstLord was just like any other assault 'Mech: slow, weapon- and armor-filled; it was a walking arsenal. The brilliant commander, Kym Shane, once said of assault 'Mechs, "When you pick one, you're only choosing the weapon array. The rest of it is the same no matter what." The OstLord was able to bring Ostmann Industries out of the red, but the company never fully recovered from the fiscal damage it had endured.

Type: OstLord
 Mass: 80 Tons
 Chassis: OST-IV
 Power Plant: 320
 Cruising Speed: 43.2 kph
 Maximum Speed: 64.8 kph
 Jump Jets: None
 Armor: Riese 764
 Armament:
 2 Totshlagen LRM Launchers
 1 Fuersturm-c Hvy Laser
 2 Fuersturm-b Mdm Lasers
 Manufacturer:
 Ostmann Industries
 Communications System:
 Ostmann-V
 Targeting & Tracking System:
 Ferdinand-g

Type: OSL-9R Ostlord	80.0
Internal Structure:	8.0
Engine: 320 Pitban	22.5
Walk MP:	4
Run MP:	6
Jump MP:	0
Heat Sinks:	15 5.0
Gyro:	4.0
Cockpit:	3.0
Armor Factor:	232 14.5
	IS AV
Head	3 8
C T	25 38
C T (R)	- 10
R/L T	17 24
R/L T (R)	- 8
R/L Arm	13 24
R/L Leg	17 32

Weapons & Ammo

Name	Loc	Crit	Tons
LRM-15	RT	3	7.0
8 Ammo	RT	1	1.0
LRM-15	LT	3	7.0
8 Ammo	LT	1	1.0
Large Laser	CT	2	5.0
Med Laser	H	1	1.0
Med Laser	LT(R)	1	1.0

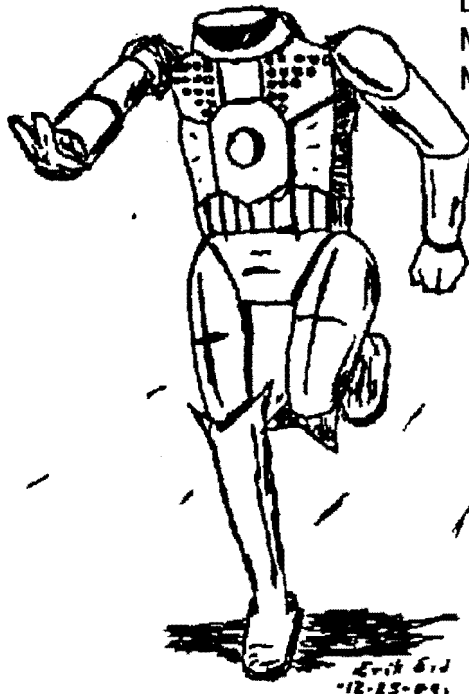

by Ken Lemons

Overview

From the Morrel factories of New Phoenix comes the SHP-3P Super Hawk, a multi-function Assault 'Mech. Based on the highly successful Shadow Hawk, the Super Hawk was created in response to the need for a heavier jump-capable 'Mech. It was meant to deal with increased numbers of heavier 'Mechs showing up on the battlefield during the Fourth Succession War. Since it shares many systems with the lighter and more numerous Shadow Hawk and Phoenix Hawk 'Mechs, spare parts are numerous and easily obtained.

The Super Hawk has been designed for MechWarriors by MechWarriors. Captain Munter of the Legion of Phoenix and captured Liao warrior Commander Lemons (now with the L.O.P.) designed this magnificent machine. The soul of the Super Hawk is the Lemons Chassis. This Chassis was scoffed at when first seen by the Liao engineers. However it has proven to be quite adaptable and enabled the 'Mech to hold the additional weight of the weapons, armor and jump jets.

According to the Means Mechanical Cost Data guide for 3040 (which follows the MechWarrior rules), the Super Hawk costs 53,727,112.50 brand new from the factory. Jayne's BattleMechs of 3030-3040 lists the Super Hawk as an experimental design used primarily by House Davion as a raiding 'Mech, created by unknown designers.

Capabilities

The Super Hawk is equipped

with a mixed group of weapons suitable to give it a punch at all combat ranges. The Donal PPC and the Morrel LRM-10 rack provide long range support. Closer in, the medium and small lasers give it good short range firepower. Having the LRM-10 mounted on the right

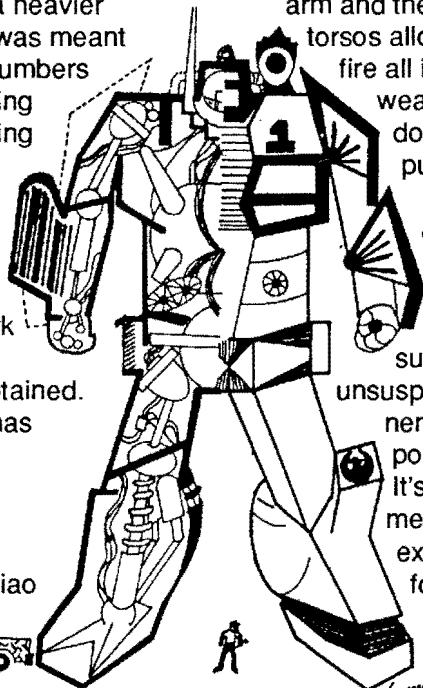

arm and the lasers in the torsos allows the mech to fire all its close assault weapons and still do a powerful punch.

The Jump Jets allow an advantage in close situations and have surprised many unsuspecting opponents with a quick position change. Its long leap (120 meters) provides excellent mobility for crossing rough terrain as well as deadly maneuvering in the urban

setting.

The large number of heat sinks make this a generally heat safe 'Mech, though firing all weapons and jumping at the same time can cause some overheating problems. But with its particular mix of weapons this becomes unlikely to occur.

The Sparrow 400J life support system is highly advanced and allows a long term comfort factor, helping to keep the pilot sharp for the long campaign. The Sparrow system features the Oasis environmental control unit. The Oasis unit keeps the cockpit 30-40% cooler during battle. Included in the cockpit are a mini microwave oven and mini refrigerator so that the pilot can have something cool to drink or

prepare a small meal during quiet moments. The pilot's seat is a couch that may be repositioned into a bed. Many testing MechWarriors preferred to sleep in their 'Mech at night rather than pitch a tent while in the field. The entire cockpit unit may be blasted free in an emergency and then float to the ground by parachute. This may provide some shelter after ejection to the grounded pilot.

The electronics systems include the Tek Tru-Trak targeting system. This system, which is nearly of Star League quality, gives the Super Hawk a deadly accurate fire. The multi-channel Tek Battle Com communications gear has heavy shielding and excellent range, making the Super Hawk well suited for the forward command role. To enhance this, the Apple 3030 Battle Computer has been added and provides information display equal to that of those found in the most sophisticated HQ vehicles. The Apple 3030 includes special programming which enables it to assign variable names immediately upon encountering unknown or variant 'Mechs. The only drawback to this system is that once damaged, it cannot be replaced or repaired by most available field components. It must be sent back to the factory for replacement.

Battle History

A new 'Mech, its battle history is short. Currently, it is only in use by the mysterious Legion of Phoenix (L.O.P.) and House Davion. It is known that Commander Lemons was captured at the beginning of the Fourth Succession War, but was not seen again and presumed dead. He returned near the end of the war piloting the Super Hawk on a raid on a Liao border planet. In that premier engagement it showed it was well able to take hits and keep functioning. Its firepower was

good and it showed remarkable control while jumping. It's first "Death from Above" hit an opposing Marauder and drove it from the battlefield. More of them have been seen in other raids since then, and they have defeated every thing from Awesomes to Victors. Based on these reports, the Super Hawk appears to be a success and more will be produced. No variants have as yet been made. However, it seems that the Legion of Phoenix Super Hawks have a different alloy in their armor plating, reason unknown.

Notable MechWarriors

The only identified MechWarrior is Commander Ken "Popcorn" Lemons, formally of House Liao. Now serving with the L.O.P., he is the pilot which drove the Marauder from the field of battle during the first engagement of the Super Hawk. He has, since then, made 12 recorded kills in his Super Hawk.

His call sign "Popcorn" was earned when he tried to make some of the treat from some non Terran corn on the planet he was garrisoned at while still a MechWarrior with House Liao. Apparently, he burned down half the barracks in his attempt.

His style of battle is an aggressive one. It is noted that during battle, he will always run towards an enemy as fast as possible. He leads his Lance in the same manner. This style of fighting combined with the abilities of the Super Hawk make him an especially deadly enemy to encounter.

Commander Lemons has also equipped his Super Hawk with a high density CD player and double sized external speakers. He had done the same thing with his Shadow Hawk while with House Liao. During battle, he turns the external speakers on to the max

Mass: 80 Tons

Chassis: Lemons 80-A

Power Plant: 320 Boeing

Cruising Speed: 42.1 kph

Maximum Speed: 61.8 kph

Jump Jets: Dwarf Industries Super Jollies

Jump Capacity: 120 meters

Armor: Munter Mithral

Armament:

1 Donal PPC

1 Morrel LRM-10 Rack

2 Chenevy Medium Lasers

2 Chenevy Small Lasers

Manufacturer:

Morrel Industries of Phoenix

Communications System:

Tek Battle Com

Targeting & Tracking:

Tek Tru-Trak

and plays an ancient type of music known as 'metal'. He has been heard to say that he doesn't like metal and prefers the style of music called "J. Buffet" but that the metal music is very distracting to the enemy.

The Super hawk is numerous among some Davion units, but no Davion warrior has taken one into battle.

It should be noted here that there is a 5,000,000 C-Bill reward offered by Romano Liao for the capture of a Super Hawk and Commander Lemons, dead or alive. Apparently the Liao engineers didn't bother to save a copy of the chassis design.

Type:	SHP-3P SuperHawk	80.0
Internal Structure:		8.0
Engine:	320	22.5
Walk MP:	4	
Run MP:	6	
Jump MP:	4	4.0
Heat Sinks:	18	8.0
Gyro:		4.0
Cockpit:		3.0
Armor Factor:	240	15.0
	IS	AV
Head	3	9
C T	25	39
C T (R)	-	11
R/L T	17	24
R/L T (R)	-	4
R Arm	13	17
L Arm	13	26
R/L Leg	17	31

Weapons & Ammo

Name	Loc	Crit	Tons
PPC	LT	3	7.0
LRM-10	RA	2	5.0
12 Ammo	RA	1	1.0
Med Laser	RT	1	1.0
Med Laser	RT	1	1.0
Small Laser	LT	1	.5
Jump Jets 2 x CT, 1 x R/LT			

RK-BU3 Rook

FUTURE WARS

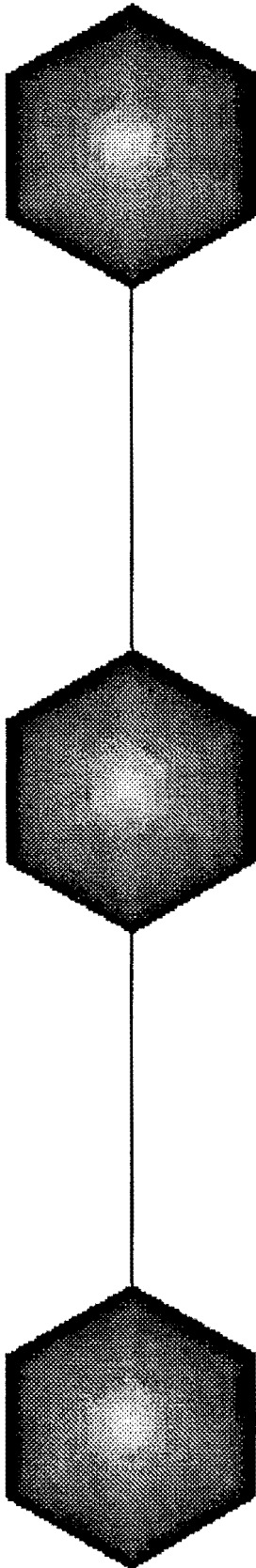

Type: RK-BU3 Rook	100.0
Internal Structure:	10.0
Engine: 300 Vlar	19.0
Walk MP: 3	
Run MP: 5	
Jump MP: 3	6.0
Heat Sinks: 22	12.0
Gyro:	3.0
Cockpit:	3.0
Armor Factor: 304	19.0
	IS AV
Head	3 9
CT	31 48
CT (R)	- 14
R/L T	21 30
R/L T (R)	- 12
R/L Arm	17 33
R/L Leg	21 41/42

Weapons & Ammo

<u>Name</u>	<u>Loc</u>	<u>Crit</u>	<u>Tons</u>
PPC	RA	3	7.0
PPC	LT	3	7.0
SRM-6	LA	2	3.0
SRM-6	RA	2	3.0
30 Ammo	RT	2	2.0
Medium Laser	RT	1	1.0
Medium Laser	LT	1	1.0
Medium Laser	CT(R)	1	1.0
2 x Jump Jets in RL, LL.			
Heat Sinks 3x RA, RT; 4 x LA.			

by Bert Ulrich

If you want a 'Mech that kicks some butt, this one's for you. It's big; It's bad; It's mean; It likes to kill other 'Mechs. I think it aptly named and if you give it a try I believe you will too. With three Jump movement points it becomes far superior to the likes of an Atlas or Stalker; well worth the six tons. Twenty-two heat sinks give it a lot of options as far as what you want to fire. If you notice, it has all direct-fire weaponry so you shouldn't keep it hidden. If any of your opponents are stupid enough to close with this monster, let 'em have it! I'm sure he'll think twice about ever attempting such a maneuver again. The twin PPC's are choice for distance so run and fire them all you want. It has nineteen whopping tons of armor so it may attract some attention. As for close-up, three SRM-6's and two Medium Lasers should be enough to stifle any plans of taking this guy out (again, no need to worry about heat). One drawback may be that the enemy will steer clear of this guy and it's speed may prevent it from pursuing. Expect it to divert the enemy sometimes. Otherwise, get out there and kick some a<<!

**YOUR DESIGN
COULD BE
HERE!**

WHY ISN'T IT?

**SUBMIT YOUR
VEHICLE,
BATTLEMECH, OR
FIGHTER DESIGNS TO
FUTURE
WARS**

**C/O HERB BARENTS
17187 WILDEMERE
DETROIT, MI
48221**

**BE PART OF THE WAR
EFFORT- FIGHT FOR**

**YOUR IDEAS AND
DESIGNS IN
FUTURE
WARS**

WHK-2A1 WARHAWK

by Michael J. Hendriks

Type: WHK-2A1 Warhawk
Internal Structure: Standard
Engine: 360 XL
Walk MP: 4
Run MP: 6
Jump MP: 4

Heat Sinks: 10 [20]

Gyro:

Cockpit:

Armor Factor: 279

	IS	AV
Head	3	9
CT	29	46
CT (R)	-	12
R/L T	19	30
R/L T (R)	-	8
R/L Arm	15	30
R/L Leg	19	38

Weapons & Ammo

Name	Loc	Crit	Tons
Gauss Rifle	RA	7	15.0
16 Ammo	RT	2	2.0
CASE	RT	1	0.5
SRM-6	RT	2	3.0
SRM-6	LT	2	3.0
30 Ammo	LT	2	2.0
CASE	LT	1	0.5
LRM-5	LA	1	2.0
LRM-5	LA	1	2.0
48 Ammo	LA	2	2.0

2 x Jump Jets in CT, 1 x RT, LT.

This 'Mech was created using the technology commonly available to the Inner Sphere in 3053.

TEMPEST

by Orion Beadling

90.0 Type: Tempest (Clan)
90.0 Internal Structure: Endo-Steel
16.5 Engine: 380 XL
Walk MP: 4
Run MP: 6
Jump MP: 4

8.0 Heat Sinks: 15 [30]

4.0 Gyro:

3.0 Cockpit:

17.5 Armor Factor: 288

	IS	AV
Head	3	9
CT	30	44
CT (R)	-	15
R/L T	20	30
R/L T (R)	-	10
R/L Arm	16	30
R/L Leg	20	40

Name	Loc	Crit	Tons
ER S Laser	H	1	0.5
Lg P Laser	RA	2	6.0
ER Lg Laser	RA	1	4.0
Med Pls Las	RT	1	2.0
Med Pls Las	RT	1	2.0
ER Sm Las	RT	1	0.5
ER Sm Las	RT	1	0.5
ER Sm Las	RT	1	0.5
Targ Comp	RT	3	3.0
ER PPC	LA	2	6.0
Md P Las	LT	1	2.0
Md P Las	LT	1	2.0
ER S Las	LT	1	0.5
ER S Las	LT	1	0.5
ER S Las	LT	1	0.5
Targ Comp	LT	3	3.0
ER S Las	CT	1	0.5
ER S Las	CT	1	0.5

The Tempest was designing a system called "Heat Exchange". Basically, the 'Mech makes near-full usage of the heat sinks it has, firing weapons appropriate for the range without over heating.

RT-L3R RATTLER

by Orion Beadling

95.0 Type: Rattler
5.0 Internal Structure: Standard
20.5 Engine: 300 Vlar
Walk MP: 3
Run MP: 5
Jump MP: 3

8.0 Heat Sinks: 10 (20)

4.0 Gyro:

3.0 Cockpit:

15.0 Armor Factor: 304

	IS	AV
Head	03	09
CT	31	50
CT (R)	-	12
R/L T	21	35
R/L T (R)	-	07
R/L Arm	17	34
R/L Leg	21	42

Name	Loc	Crit	Tons
Med Laser	H	01	1.0
8 x Streak-2	RA	08	12.0
50 Ammo	RA	01	1.0
10 x MG	RT	10	5.0
200 Ammo	RT	01	1.0
CASE	RT	01	0.5
8 x Streak-2	LA	08	12.0
50 Ammo	LA	01	1.0
10 x MG	LT	10	5.0
200 Ammo	LT	01	1.0
CASE	LT	01	0.5

The Rattler was designed for use in the arenas of Solaris VII, especially when using dueling rules. The Streak SRM-2s build up heat only if they strike, and the machine guns don't at all. Ideally, the machine guns can be used every turn on an opponent, since the ranges are so close, and the Streaks can be fired every other turn with little chance to seriously overheat.

BATTLETECH®

ARMOR DIAGRAM

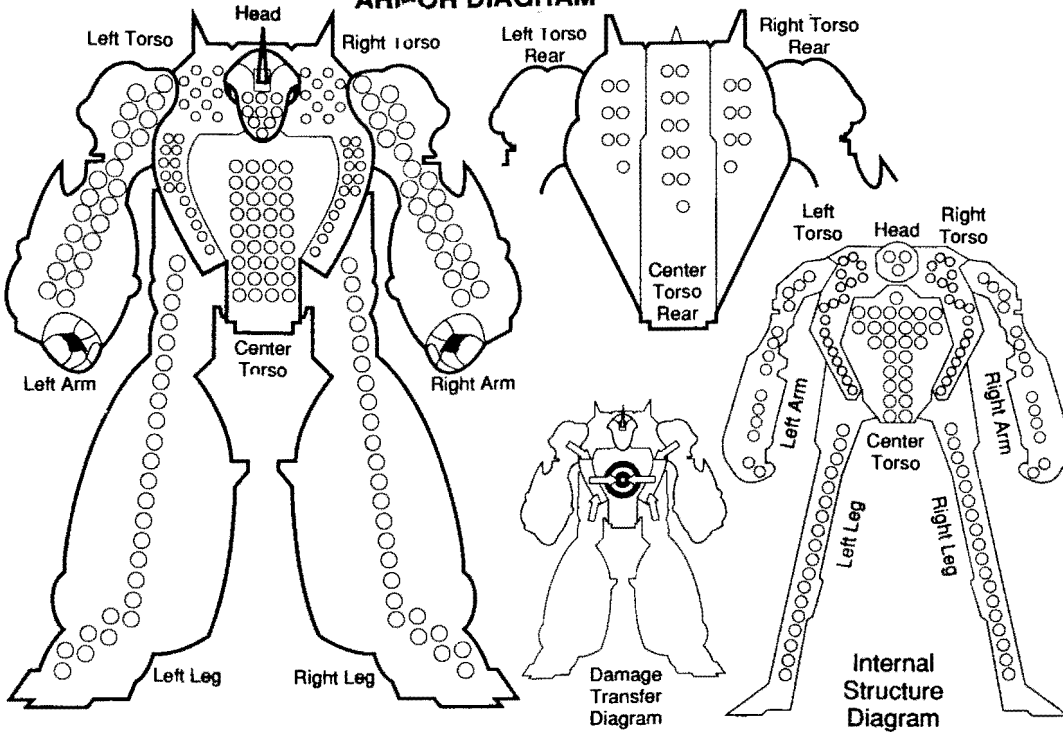

MECH DATA

Type: STK-3F STALKER

Tonnage: 85 TONS

Movement Points:

Walking: 3

Running: 5

Jumping: 0

WEAPONS INVENTORY

#	Type	Loc.
1	LRM 10	RA
1	LRM 10	LA
1	LARGE LASER	LT
1	LARGE LASER	RT
1	MEDIUM LASER	RA
1	MEDIUM LASER	RA
1	MEDIUM LASER	LA
1	MEDIUM LASER	LA
1	SRM 6	LT
1	SRM 6	RT

AMMO:

Auto Cannon Rounds: —

M.G. Rounds: —

S.R.M. Packs: — 15/15

Missiles per pack: — 6

L.R.M. Packs: — 24/24

Missiles per pack: — 10

TOTAL HEAT SINKS

○○○○○○○○○○

○○○○○○○○○○

WARRIOR DATA

Name: _____

Gunnery Skill: _____

Piloting Skill: _____

Hits Taken: (Consciousness Number)

1st 2nd 3rd 4th 5th 6th
(3) (5) (7) (10) (11) (Dead)

Left Arm

- Shoulder
- Upper Arm Actuator
- LRM 10
- LRM 10
- Heat Sink
- Medium Laser

- LRM 10 Ammo
- Medium Laser
- Roll Again
- Roll Again
- Roll Again
- Roll Again

Left Torso

- Large Laser
- Large Laser
- SRM 6
- SRM 6
- SRM 6 Ammo
- Heat Sink

- Roll Again
- Roll Again
- Roll Again
- Roll Again
- Roll Again
- Roll Again

Left Leg

- Hip
- Upper Leg Actuator
- Lower Leg Actuator
- Foot Actuator
- Heat Sink
- Heat Sink

CRITICAL HIT TABLE

Head

- Life Support
- Sensors
- Cockpit
- Roll Again
- Sensors
- Life Support

Center Torso

- Engine
- Engine
- Engine
- Gyro
- Gyro
- Gyro

- Gyro
- Engine
- Engine
- Engine
- Heat Sink
- Heat Sink

Engine Hits ○○○
Gyro Hits ○○○
Sensor Hits ○○○



Right Arm

- Shoulder
- Upper Arm Actuator
- LRM 10
- LRM 10
- Heat Sink
- Medium Laser

- LRM 10 Ammo
- Medium Laser
- Roll Again
- Roll Again
- Roll Again
- Roll Again

Right Torso

- Large Laser
- Large Laser
- SRM 6
- SRM 6
- SRM 6 Ammo
- Heat Sink

- Roll Again
- Roll Again
- Roll Again
- Roll Again
- Roll Again
- Roll Again

Right Leg

- Hip
- Upper Leg Actuator
- Lower Leg Actuator
- Foot Actuator
- Heat Sink
- Heat Sink

HEAT SCALE

30
29
28
27
26
25
24
23
22
21
20
19
18
17
16
15
14
13
12
11
10
09
08
07
06
05
04
03
02
01
00

SHUTDOWN

Ammo Explosion, avoid on 8+

Shutdown, avoid on 10+

-5 Movement Points

+4 Modifier to Fire

Ammo Explosion, avoid on 6+

Shutdown, avoid on 8+

-4 Movement Points

Ammo Explosion, avoid on 4+

Shutdown, avoid on 6+

+3 Modifier to Fire

-3 Movement Points

Shutdown, avoid on 4+

+2 Modifier to Fire

-2 Movement Points

+1 Modifier to Fire

-1 Movement Point

The Stalker: +1 penalty to all piloting skill rolls to avoid falling; no physical attacks; no arm firing arcs; no torso twists; rear-arc head hits are changed to rear CT hits; AC and punch hits on torsos are -2 on damage; laser hits on torsos are -1 damage.

BATTLETECH®

ARMOR DIAGRAM

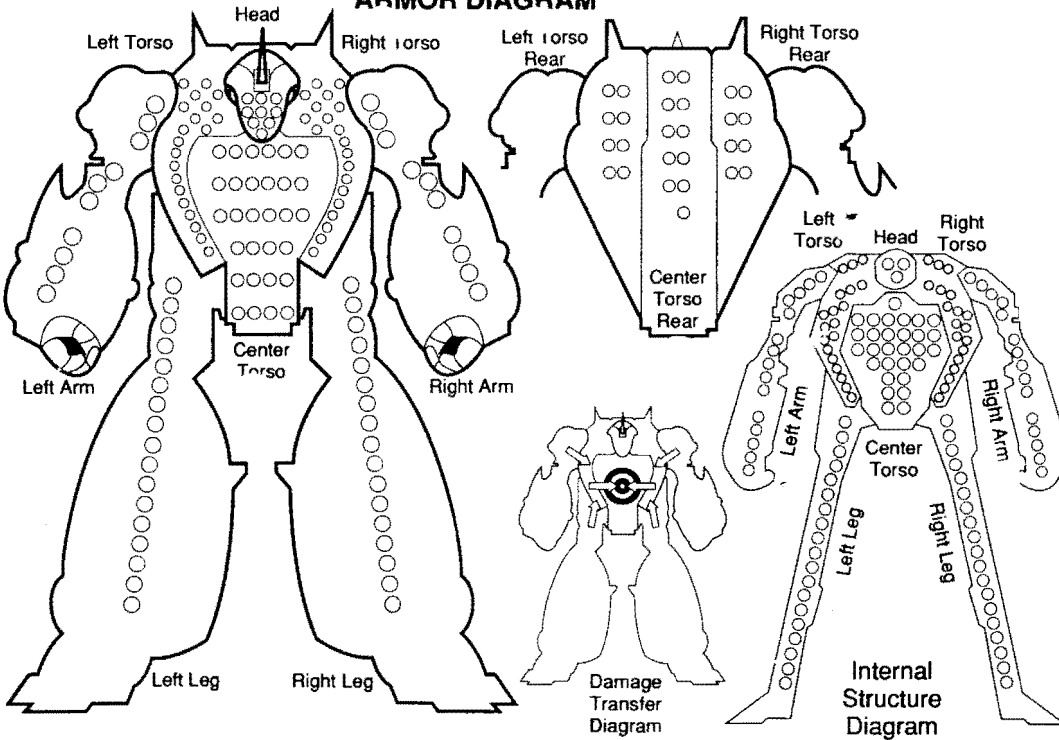

MECH DATA

Type: CP 10-Z CYCLOPS
 Tonnage: 90 TONS
 Movement Points:
 Walking: 4
 Running: 6
 Jumping: 0

WEAPONS INVENTORY

#	Type	Loc.
1	AUTOCANNON/20	RT
1	LRM 10	LT
1	MEDIUM LASER	RA
1	MEDIUM LASER	LA
1	SRM 4	CT

AMMO:

Auto Cannon Rounds: — 20
 M.G. Rounds: —
 S.R.M. Packs — 25
 Missiles per pack — 4
 L.R.M. Packs — 12
 Missiles per pack — 10

TOTAL HEAT SINKS

○○
 ○○○○○○○○

WARRIOR DATA

Name: _____
 Gunnery Skill: _____
 Piloting Skill: _____
 Hits Taken: (Consciousness Number)

1st	2nd	3rd	4th	5th	6th
(3)	(5)	(7)	(10)	(11)	(Dead)

CRITICAL HIT TABLE

Left Arm	Head	Right Arm
1. Shoulder	1. Life Support	1. Shoulder
2. Upper Arm Actuator	2. Sensors	2. Upper Arm Actuator
3. Lower Arm Actuator	3. Cockpit	3. Lower Arm Actuator
4. Hand Actuator	4. Roll Again	4. Hand Actuator
5. Medium Laser	5. Sensors	5. Medium Laser
6. Roll Again	6. Life Support	6. Heat Sink
1. Roll Again		1. Roll Again
2. Roll Again		2. Roll Again
3. Roll Again		3. Roll Again
4. Roll Again		4. Roll Again
5. Roll Again		5. Roll Again
6. Roll Again		6. Roll Again
Left Torso	Center Torso	Right Torso
1. AC/20 Ammo	1. Engine	1. AC/20
2. AC/20 Ammo	2. Engine	2. AC/20
3. LRM 10	3. Engine	3. AC/20
4. LRM 10	4. Gyro	4. AC/20
5. LRM 10 Ammo	5. Gyro	5. AC/20
6. Heat Sink	6. Gyro	6. AC/20
1. Roll Again	1. Gyro	1. AC/20
2. Roll Again	2. Engine	2. AC/20
3. Roll Again	3. Engine	3. AC/20
4. Roll Again	4. Engine	4. AC/20
5. Roll Again	5. SRM 4	5. AC/20 Ammo
6. Roll Again	6. SRM 4 Ammo	6. AC/20 Ammo
Left Leg		Right Leg
1. Hip		1. Hip
2. Upper Leg Actuator		2. Upper Leg Actuator
3. Lower Leg Actuator		3. Lower Leg Actuator
4. Foot Actuator		4. Foot Actuator
5. Roll Again		5. Roll Again
6. Roll Again		6. Roll Again

Engine Hits ○○○○
 Gyro Hits ○○○○
 Sensor Hits ○○○○



HEAT SCALE

30	SHUTDOWN
29	
28	Ammo Explosion, avoid on 8+
27	
26	Shutdown, avoid on 10+
25	-5 Movement Points
24	+4 Modifier to Fire
23	Ammo Explosion, avoid on 6+
22	Shutdown, avoid on 8+
21	
20	-4 Movement Points
19	Ammo Explosion, avoid on 4+
18	Shutdown, avoid on 6+
17	+3 Modifier to Fire
16	
15	-3 Movement Points
14	Shutdown, avoid on 4+
13	+2 Modifier to Fire
12	
11	
10	-2 Movement Points
09	
08	+1 Modifier to Fire
07	
06	
05	-1 Movement Point
04	
03	
02	
01	
00	

BATTLETECH is a registered trademark of FASA Corporation. Copyright 1987. Permission to photocopy for personal use.

The Cyclops: +1 penalty to all piloting skill rolls to avoid falling; punches do 7 points; kicks do 15 points; +1 bonus to hit and on the number of missiles roll with LRM until first head hit; no charges allowed; the AC-20 has a 1-hex offset firing arc to the right; must check for laser malfunction on a punch.

BATTLETECH®

ARMOR DIAGRAM

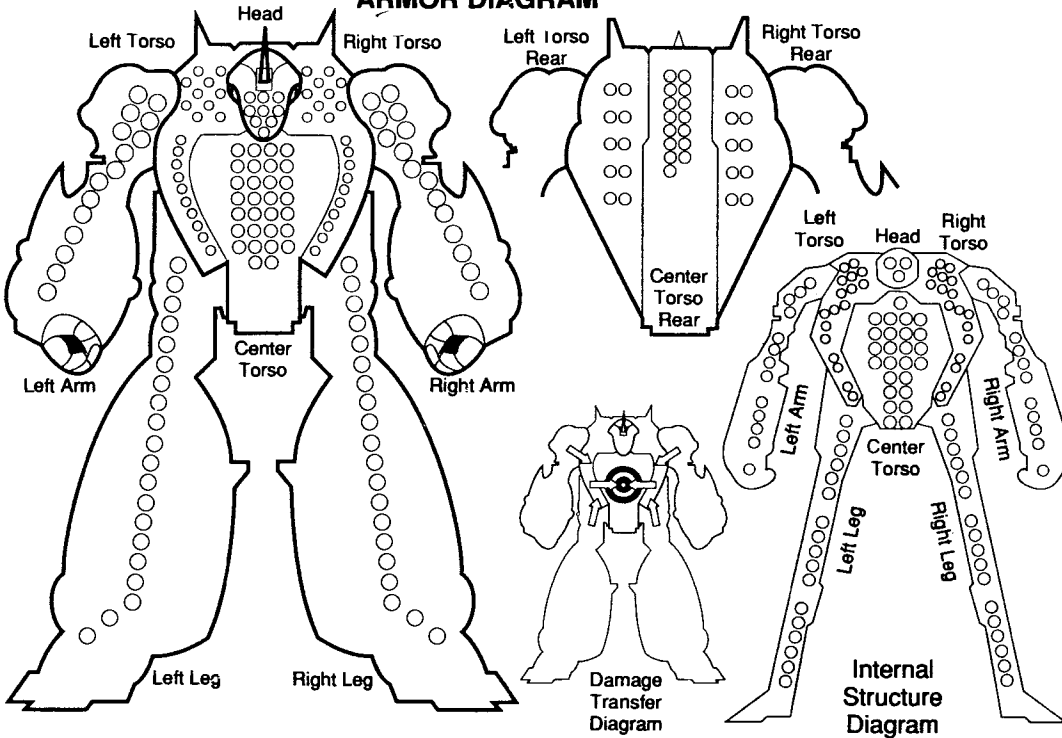

MECH DATA

Type: VTR 9B VICTOR
 Tonnage: 80 TONS
 Movement Points:
 Walking: 4
 Running: 6
 Jumping: 4

WEAPONS INVENTORY

#	Type	Loc.
1	AUTOCANNON/20	RA
1	MEDIUM LASER	LA
1	MEDIUM LASER	LA
1	SRM 4	LT

AMMO:

Auto Cannon Rounds: — 15
 M.G. Rounds: —
 S.R.M. Packs — 25
 Missiles per pack. — 4
 L.R.M. Packs —
 Missiles per pack. —

TOTAL HEAT SINKS

○○○○○
 ○○○○○○○○○○

WARRIOR DATA

Name: _____
 Gunnery Skill: _____
 Piloting Skill: _____
 Hits Taken: (Consciousness Number)
 1st 2nd 3rd 4th 5th 6th
 (3) (5) (7) (10) (11) (Dead)

Left Arm

- Shoulder
- Upper Arm Actuator
- Lower Arm Actuator
- Hand Actuator
- Medium Laser
- Medium Laser

- Roll Again
- Roll Again
- Roll Again
- Roll Again
- Roll Again
- Roll Again

Left Torso

- SRM 4
- SRM 4 Ammo
- Heat Sink
- Heat Sink
- Roll Again
- Roll Again

- Roll Again
- Roll Again
- Roll Again
- Roll Again
- Roll Again
- Roll Again

Left Leg

- Hip
- Upper Leg Actuator
- Lower Leg Actuator
- Foot Actuator
- Jump Jet
- Heat Sink

CRITICAL HIT TABLE

Head

- Life Support
- Sensors
- Cockpit
- Roll Again
- Sensors
- Life Support

Center Torso

- Engine
 - Engine
 - Engine
 - Gyro
 - Gyro
 - Gyro
- Gyro
 - Engine
 - Engine
 - Engine
 - Jump Jet
 - Jump Jet

Engine Hits ○○○
 Gyro Hits ○○○
 Sensor Hits ○○○

Right Arm

- Shoulder
- Upper Arm Actuator
- AC/20
- AC/20
- AC/20
- AC/20

- AC/20
- AC/20
- AC/20
- AC/20
- AC/20
- AC/20

Right Torso

- AC/20 Ammo
- AC/20 Ammo
- AC/20 Ammo
- Heat Sink
- Roll Again
- Roll Again

- Roll Again
- Roll Again
- Roll Again
- Roll Again
- Roll Again
- Roll Again

Right Leg

- Hip
- Upper Leg Actuator
- Lower Leg Actuator
- Foot Actuator
- Jump Jet
- Heat Sink

HEAT SCALE

30	SHUTDOWN
29	
28	Ammo Explosion, avoid on 8+
27	
26	Shutdown, avoid on 10+
25	-5 Movement Points
24	+4 Modifier to Fire
23	Ammo Explosion, avoid on 6+
22	Shutdown, avoid on 8+
21	
20	-4 Movement Points
19	Ammo Explosion, avoid on 4+
18	Shutdown, avoid on 6+
17	+3 Modifier to Fire
16	
15	-3 Movement Points
14	Shutdown, avoid on 4+
13	+2 Modifier to Fire
12	
11	
10	-2 Movement Points
09	
08	+1 Modifier to Fire
07	
06	
05	-1 Movement Point
04	
03	
02	
01	
00	



BATTLETECH is a registered trademark of FASA Corporation. Copyright 1987. Permission to photocopy for personal use.

The Victor: No rear-arc head hits until rear CT armor is gone; no torso twist; punch only with left arm; no left arm firing arcs; +1 penalty to all piloting skill rolls to avoid falling; AC-20 can fire during a death-from-above.

BATTLETECH®

Armor Diagram

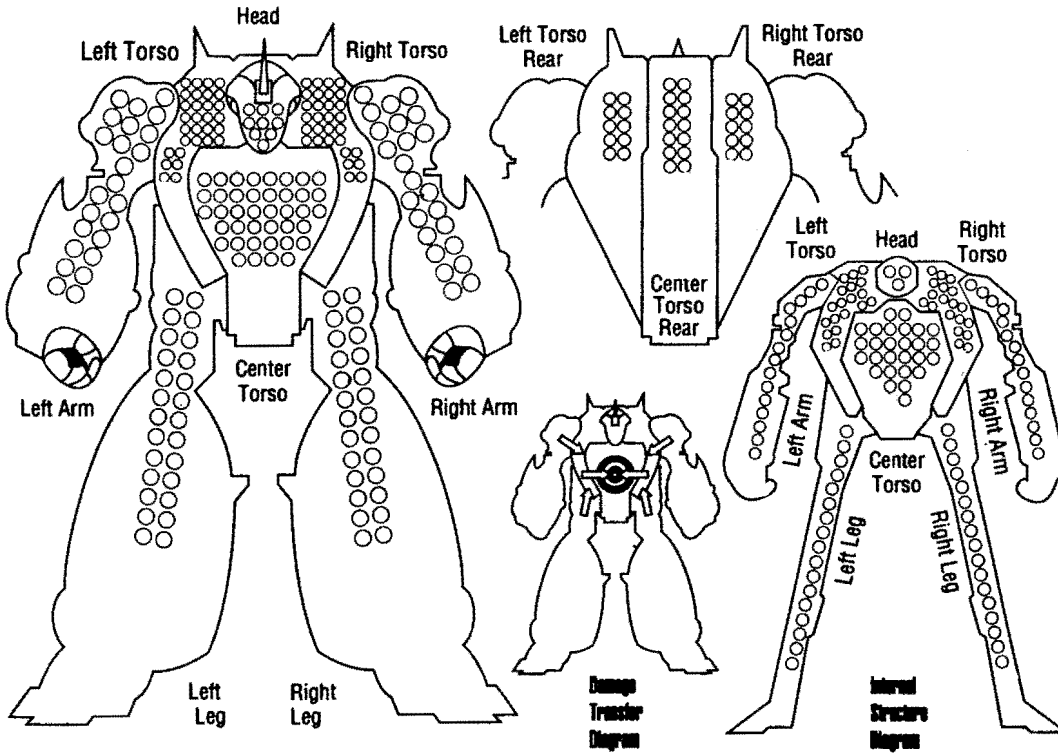

Mech Data

Type: ARCHER II (HAVOC)
 Tonnage: 85
 Movement Points:
 Walking: 3
 Running: 5
 Jumping: _____

Weapons Inventory

#	Type	Location
1	ARROW IV	RA-RT
1	ARROW IV	LA-LT
1	MED PLS LAS	LT
1	LRG LASER	CT

Pod Space: _____
 AMMO: ARROW IV
 Auto Cannon Rounds: 30
 M.G. Rounds: _____
 S.R.M. Packs: _____
 Missiles per pack: _____
 L.R.M. Packs: _____
 Missiles per pack: _____

Total Heat Sinks

○○○○○○○○○ Double

Warrior Data

Name: _____
 Gunnery Skill: _____
 Piloting Skill: _____
 Hits Taken: (Consciousness Number)
 1st 2nd 3rd 4th 5th 6th
 (3) (5) (7) (10) (11) (Dead)

Left Arm

- Shoulder
 - Upper Arm Actuator
 - Lower Arm Actuator
 - Hand Actuator
 - ARROW IV
 - ARROW IV
- ARROW IV
 - ARROW IV
 - ARROW IV
 - ARROW IV
 - ARROW IV
 - ARROW IV

Left Torso

- ARROW IV
 - ARROW IV
 - ARROW IV
 - ARROW IV
 - ARROW IV
 - ARROW IV
- ARROW IV
 - MED PLS LASER
 - ARROW IV Ammo (5)
 - ARROW IV Ammo (5)
 - ARROW IV Ammo (5)
 -

Left Leg

- Hip
- Upper Leg Actuator
- Lower Leg Actuator
- Foot Actuator
- C³MASTER
- C³MASTER

Critical Hit Table

Head

- Life Support
- Sensors
- Cockpit
- C³MASTER
- Sensors
- Life Support

Center Torso

- Engine
 - Engine
 - Engine
 - Gyro
 - Gyro
 - Gyro
- Gyro
 - Engine
 - Engine
 - Engine
 - LRG LASER
 - LRG LASER

Engine Hits ○○○
 Gyro Hits ○○
 Sensor Hits ○○

Right Arm

- Shoulder
 - Upper Arm Actuator
 - Lower Arm Actuator
 - Hand Actuator
 - ARROW IV
 - ARROW IV
- ARROW IV
 - ARROW IV
 - ARROW IV
 - ARROW IV
 - ARROW IV
 - ARROW IV

Right Torso

- ARROW IV
 - ARROW IV
 - ARROW IV
 - ARROW IV
 - ARROW IV
 - ARROW IV
- ARROW IV
 - ARROW IV Ammo (5)
 - ARROW IV Ammo (5)
 - ARROW IV Ammo (5)
 -
 -

Right Leg

- Hip
- Upper Leg Actuator
- Lower Leg Actuator
- Foot Actuator
- C³MASTER
- C³MASTER

Heat Scale

30	Shutdown
29	
28	Ammo Explosion, avoid on 8+
27	
26	Shutdown, avoid on 10+
25	-5 Movement Points
24	+4 Modifier to Fire
23	Ammo Explosion, avoid on 6+
22	Shutdown, avoid on 8+
21	
20	-4 Movement Points
19	Ammo Explosion, avoid on 4+
18	Shutdown, avoid on 6+
17	+3 Modifier to Fire
16	
15	-3 Movement Points
14	Shutdown, avoid on 4+
13	+2 Modifier to fire
12	
11	
10	-2 Movement Points
09	
08	-1 Modifier to Fire
07	
06	
05	-1 Movement Points
04	
03	
02	
01	
00	

BATTLETECH®

Armor Diagram

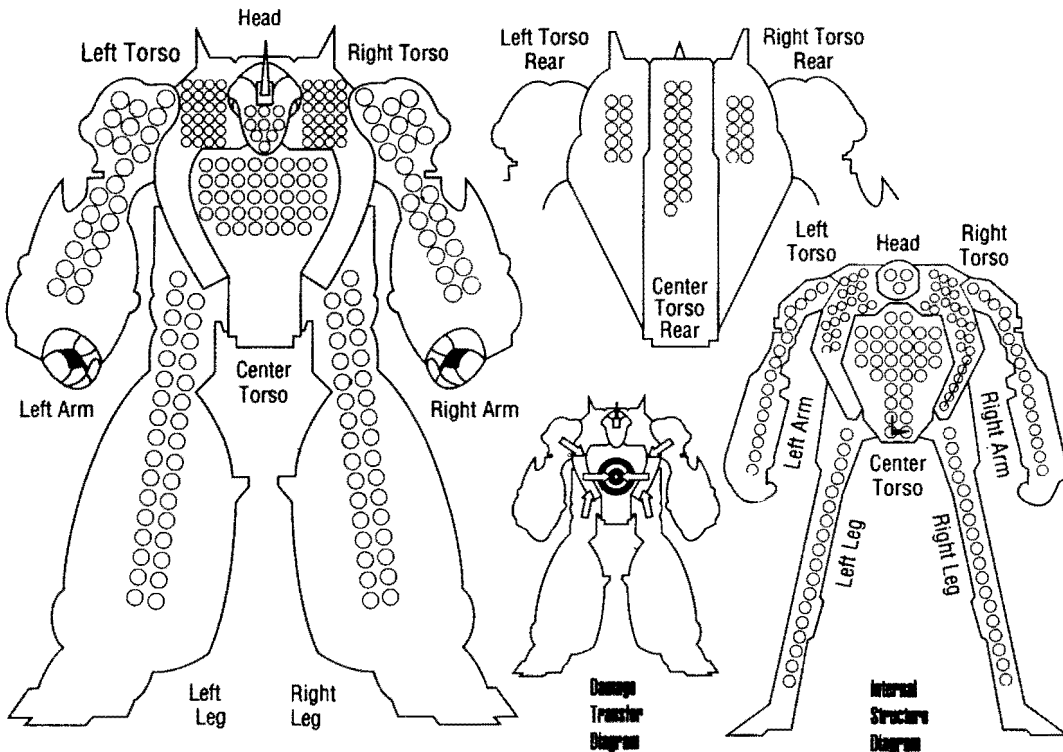

Mech Data

Type: AWESOME JAGER
 Tonnage: 90
 Movement Points: _____
 Walking: 3
 Running: 5
 Jumping: _____

Weapons Inventory

#	Type	Location
<u>2</u>	<u>AC-5</u>	<u>R,LA</u>
<u>2</u>	<u>AC-2</u>	<u>R,LA</u>
<u>2</u>	<u>MED LAS</u>	<u>R,LT</u>
<u>1</u>	<u>SM LAS</u>	<u>H</u>

Pod Space: _____
 AMMO: _____
 Auto Cannon Rounds: 40 AC-5 / 45 AC-2
 M.G. Rounds: _____
 S.R.M. Packs: _____
 Missiles per pack: _____
 L.R.M. Packs: _____
 Missiles per pack: _____

Total Heat Sinks

○○○○○○○○○○ Single
 ○○○
 ○○○○○○○○

Warrior Data

Name: _____
 Gunnery Skill: _____
 Piloting Skill: _____
 Hits Taken: (Consciousness Number)
 1st 2nd 3rd 4th 5th 6th
 (3) (5) (7) (10) (11) (Dead)

Left Arm

- Shoulder
 - Upper Arm Actuator
 - Lower Arm Actuator
 - Hand Actuator
 - AC-5
 - AC-5
- AC-5
 - AC-5
 - AC-2
 - HEAT SINK
 - HEAT SINK
 - _____

Left Torso

- AC-5 Ammo (20)
 - MED LASER
 - HEAT SINK
 - HEAT SINK
 - HEAT SINK
 - _____
- _____
 - _____
 - _____
 - _____
 - _____
 - _____

Left Leg

- Hip
- Upper Leg Actuator
- Lower Leg Actuator
- Foot Actuator
- HEAT SINK
- _____

Critical Hit Table

Head

- Life Support
- Sensors
- Cockpit
- SM LASER
- Sensors
- Life Support

Center Torso

- Engine
 - Engine
 - Engine
 - Gyro
 - Gyro
 - Gyro
- Gyro
 - Engine
 - Engine
 - Engine
 - AC-2 Ammo (45)
 - _____

Engine Hits ○○○○
 Gyro Hits ○○○○
 Sensor Hits ○○○○

Right Arm

- Shoulder
 - Upper Arm Actuator
 - Lower Arm Actuator
 - Hand Actuator
 - AC-5
 - AC-5
- AC-5
 - AC-5
 - AC-2
 - HEAT SINK
 - HEAT SINK
 - _____

Right Torso

- AC-5 Ammo (20)
 - MED LASER
 - HEAT SINK
 - HEAT SINK
 - HEAT SINK
 - _____
- _____
 - _____
 - _____
 - _____
 - _____
 - _____

Right Leg

- Hip
- Upper Leg Actuator
- Lower Leg Actuator
- Foot Actuator
- HEAT SINK
- _____

Heat Scale

30	Shutdown
29	
28	Ammo Explosion, avoid on 8+
27	
26	Shutdown, avoid on 10+
25	-5 Movement Points
24	+4 Modifier to Fire
23	Ammo Explosion, avoid on 6+
22	Shutdown, avoid on 8+
21	
20	-4 Movement Points
19	Ammo Explosion, avoid on 4+
18	Shutdown, avoid on 6+
17	+3 Modifier to Fire
16	
15	-3 Movement Points
14	Shutdown, avoid on 4+
13	+2 Modifier to fire
12	
11	
10	-2 Movement Points
09	
08	-1 Modifier to Fire
07	
06	
05	-1 Movement Points
04	
03	
02	
01	
00	

BATTLETECH®

Armor Diagram

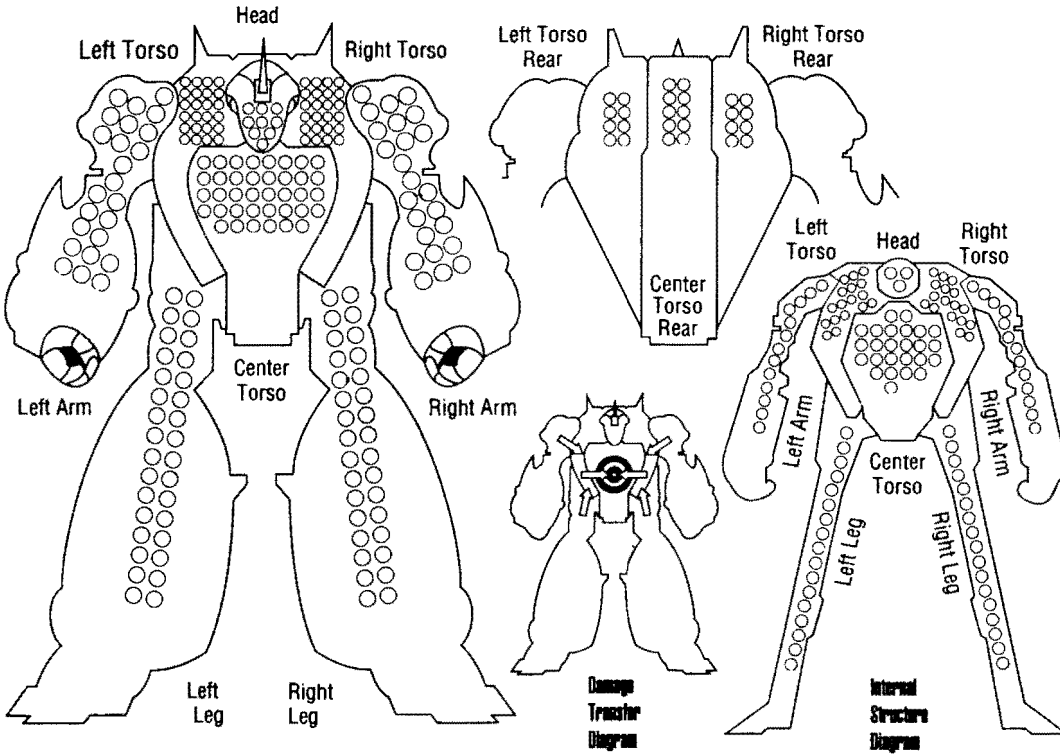

Mech Data

Type: OSL-4R Ostlund
 Tonnage: 80
 Movement Points: _____
 Walking: 4
 Running: 6
 Jumping: _____

Weapons Inventory

#	Type	Location
2	LRM-15	LT, RT
1	LA-LASER	CT
2	MED LASER	H, TR

Pod Space: _____
 AMMO:
 Auto Cannon Rounds: _____
 M.G. Rounds: _____
 S.R.M. Packs: _____
 Missiles per pack: _____
 L.R.M. Packs: 14
 Missiles per pack: 15

Total Heat Sinks

○○○○○○○○○○ Single
 ○○○○

Warrior Data

Name: _____
 Gunnery Skill: _____
 Piloting Skill: _____
 Hits Taken: (Consciousness Number)
 1st 2nd 3rd 4th 5th 6th
 (3) (5) (7) (10) (11) (Dead)

Left Arm

- Shoulder
 - Upper Arm Actuator
 - Lower Arm Actuator
 - Hand Actuator
 - _____
 - _____
- _____
 - _____
 - _____
 - _____
 - _____
 - _____

Left Torso

- LRM-15 Ammo(S)
 - LRM-15
 - LRM-15
 - LRM-15
 - MEDIAL LASER(R)
 - HEAT SINK
- _____
 - _____
 - _____
 - _____
 - _____
 - _____

Left Leg

- Hip
- Upper Leg Actuator
- Lower Leg Actuator
- Foot Actuator
- _____
- _____

Critical Hit Table

Head

- Life Support
- Sensors
- Cockpit
- MEDIAL LASER
- Sensors
- Life Support

Center Torso

- Engine
 - Engine
 - Engine
 - Gyro
 - Gyro
 - Gyro
- Gyro
 - Engine
 - Engine
 - Engine
 - LARGE LASER
 - LARGE LASER

Engine Hits ○○○○
 Gyro Hits ○○○○
 Sensor Hits ○○○○

Right Arm

- Shoulder
 - Upper Arm Actuator
 - Lower Arm Actuator
 - Hand Actuator
 - _____
 - _____
- _____
 - _____
 - _____
 - _____
 - _____
 - _____

Right Torso

- LRM-15 Ammo (8)
 - LRM-15
 - LRM-15
 - LRM-15
 - HEAT SINK
 - HEAT SINK
- _____
 - _____
 - _____
 - _____
 - _____
 - _____

Right Leg

- Hip
- Upper Leg Actuator
- Lower Leg Actuator
- Foot Actuator
- _____
- _____

Heat Scale

30	Shutdown
29	
28	Ammo Explosion, avoid on 8+
27	
26	Shutdown, avoid on 10+
25	-5 Movement Points
24	+4 Modifier to Fire
23	Ammo Explosion, avoid on 6+
22	Shutdown, avoid on 8+
21	
20	-4 Movement Points
19	Ammo Explosion, avoid on 4+
18	Shutdown, avoid on 6+
17	+3 Modifier to Fire
16	
15	-3 Movement Points
14	Shutdown, avoid on 4+
13	+2 Modifier to fire
12	
11	
10	-2 Movement Points
09	
08	-1 Modifier to Fire
07	
06	
05	-1 Movement Points
04	
03	
02	
01	
00	

BATTLETECH®

Armor Diagram

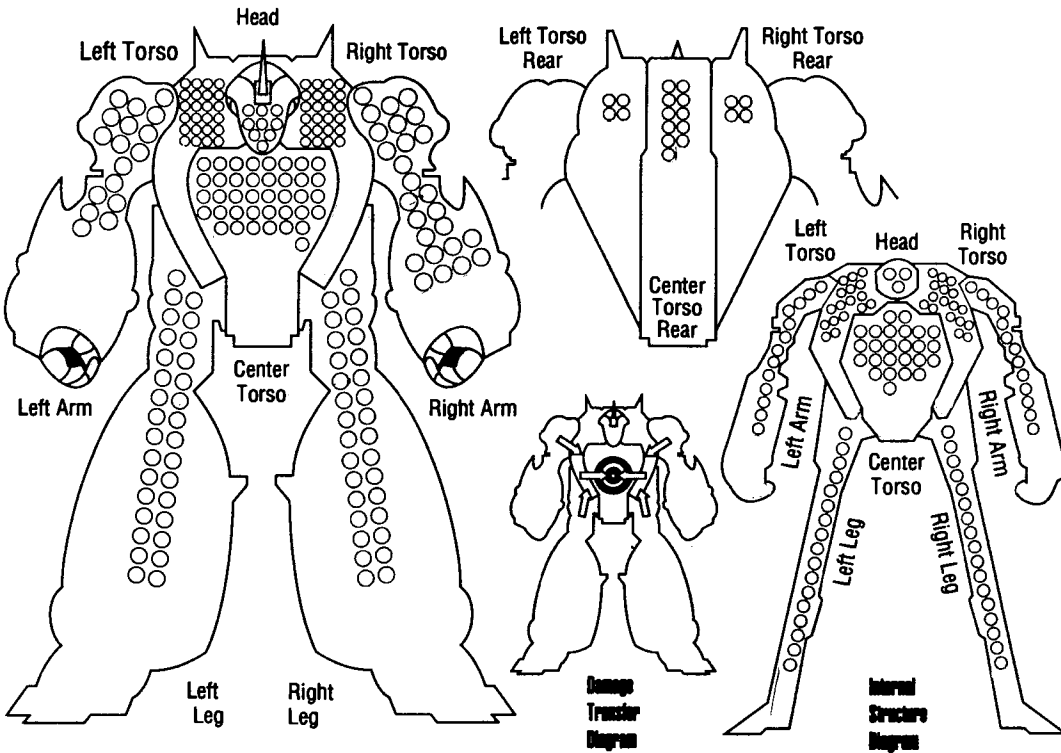

Mech Data

Type: SHP-3P SUPER HAWK
 Tonnage: 30
 Movement Points: _____
 Walking: 4
 Running: 6
 Jumping: 4

Weapons Inventory

#	Type	Location
1	PPC	LT
1	LRM-10	RA
2	M LASER	RT
1	SM LASER	LT

Pod Space: _____
 AMMO: _____
 Auto Cannon Rounds: _____
 M.G. Rounds: _____
 S.R.M. Packs: _____
 Missiles per pack: _____
 L.R.M. Packs: 12
 Missiles per pack: 10

Total Heat Sinks

Single

Warrior Data

Name: _____
 Gunnery Skill: _____
 Piloting Skill: _____
 Hits Taken: (Consciousness Number)
 1st 2nd 3rd 4th 5th 6th
 (3) (5) (7) (10) (11) (Dead)

Left Arm

- Shoulder
- Upper Arm Actuator
- Lower Arm Actuator
- Hand Actuator
- _____
- _____

Critical Hit Table

Head

- Life Support
- Sensors
- Cockpit
- HEAT SINK
- Sensors
- Life Support

Center Torso

- Engine
 - Engine
 - Engine
 - Gyro
 - Gyro
 - Gyro
- Gyro
 - Engine
 - Engine
 - Engine
 - JUMP JET
 - JUMP JET

Right Arm

- Shoulder
 - Upper Arm Actuator
 - Lower Arm Actuator
 - Hand Actuator
 - LRM-10 Ammo (12)
 - HEAT SINK
- LRM-10
 - LRM-10
 - _____
 - _____
 - _____
 - _____

Right Torso

- JUMP JET
 - MEDIUM LASER
 - MEDIUM LASER
 - HEAT SINK
 - HEAT SINK
 - _____
- _____
 - _____
 - _____
 - _____
 - _____
 - _____

Right Leg

- Hip
- Upper Leg Actuator
- Lower Leg Actuator
- Foot Actuator
- HEAT SINK
- _____

Left Torso

- JUMP JET
 - PPC
 - PPC
 - PPC
 - SMALL LASER
 - HEAT SINK
- HEAT SINK
 - HEAT SINK
 - _____
 - _____
 - _____
 - _____

Left Leg

- Hip
- Upper Leg Actuator
- Lower Leg Actuator
- Foot Actuator
- HEAT SINK
- _____

Engine Hits ○ ○ ○
 Gyro Hits ○ ○ ○
 Sensor Hits ○ ○ ○

Heat Scale

30	Shutdown
29	
28	Ammo Explosion, avoid on 8+
27	
26	Shutdown, avoid on 10+
25	-5 Movement Points
24	+4 Modifier to Fire
23	Ammo Explosion, avoid on 6+
22	Shutdown, avoid on 8+
21	
20	-4 Movement Points
19	Ammo Explosion, avoid on 4+
18	Shutdown, avoid on 6+
17	+3 Modifier to Fire
16	
15	-3 Movement Points
14	Shutdown, avoid on 4+
13	+2 Modifier to fire
12	
11	
10	-2 Movement Points
09	
08	-1 Modifier to Fire
07	
06	
05	-1 Movement Points
04	
03	
02	
01	
00	

BATTLETECH®

Armor Diagram

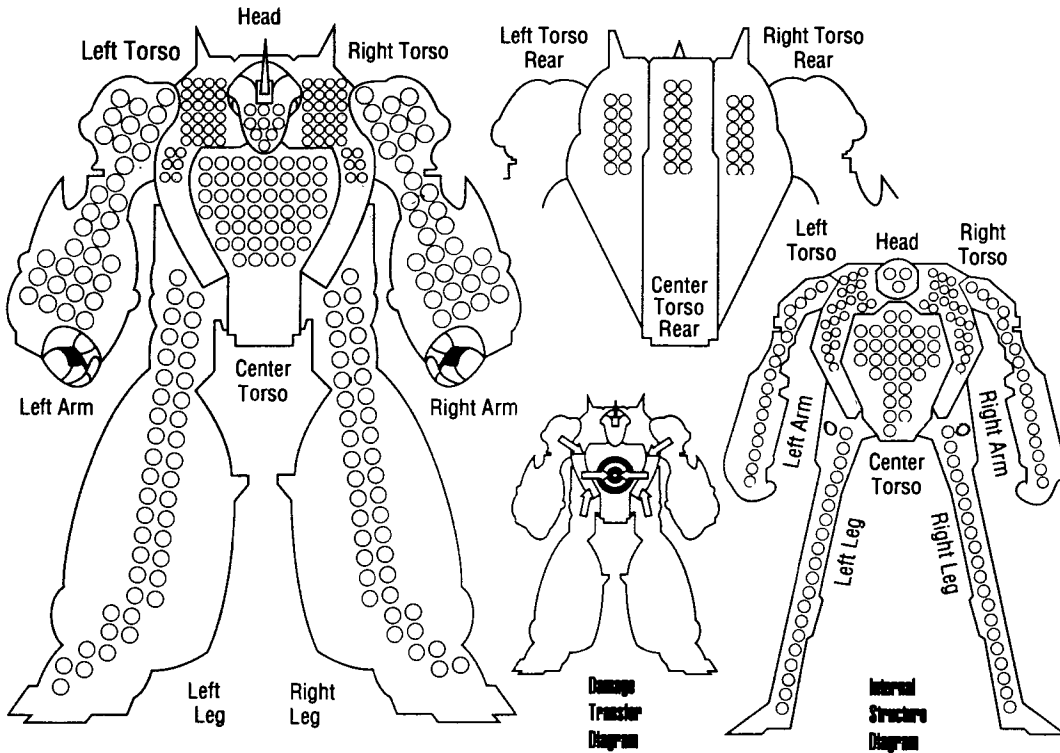

Mech Data

Type: RK-R3 Rook
 Tonnage: 100
 Movement Points: _____
 Walking: 3
 Running: 5
 Jumping: 3

Weapons Inventory

#	Type	Location
<u>2</u>	<u>PPC</u>	<u>RA, LT</u>
<u>3</u>	<u>SRM-6</u>	<u>LA, LH, RA</u>
<u>3</u>	<u>MED LASER</u>	<u>LT, RT, CTOR</u>

Pod Space: _____
 AMMO: _____
 Auto Cannon Rounds: _____
 M.G. Rounds: _____
 S.R.M. Packs: 30
 Missiles per pack: 6
 L.R.M. Packs: _____
 Missiles per pack: _____

Total Heat Sinks

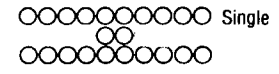

Warrior Data

Name: _____
 Gunnery Skill: _____
 Piloting Skill: _____
 Hits Taken: (Consciousness Number)
 1st 2nd 3rd 4th 5th 6th
 (3) (5) (7) (10) (11) (Dead)

Left Arm

- Shoulder
- Upper Arm Actuator
- Lower Arm Actuator
- Hand Actuator
- SRM-6
- SRM-6

- SRM-6
- SRM-6
- HEAT SINK
- HEAT SINK
- HEAT SINK
- HEAT SINK

Left Torso

- MEDIUM LASER
- PPC
- PPC
- PPC
- _____
- _____

- _____
- _____
- _____
- _____
- _____
- _____

Left Leg

- Hip
- Upper Leg Actuator
- Lower Leg Actuator
- Foot Actuator
- JUMP JET
- _____

Critical Hit Table

Head

- Life Support
- Sensors
- Cockpit
- _____
- Sensors
- Life Support

Center Torso

- Engine
 - Engine
 - Engine
 - Gyro
 - Gyro
 - Gyro
- Gyro
 - Engine
 - Engine
 - Engine
 - MEDIUM LASER (R)
 - JUMP JET

Right Arm

- Shoulder
- Upper Arm Actuator
- Lower Arm Actuator
- Hand Actuator
- SRM-6
- SRM-6

- _____ PPC
- _____ PPC
- _____ PPC
- _____ HEAT SINK
- _____ HEAT SINK
- _____ HEAT SINK

Right Torso

- SRM-6 Ammo (15)
- SRM-6 Ammo (15)
- MEDIUM LASER
- HEAT SINK
- HEAT SINK
- HEAT SINK

- _____
- _____
- _____
- _____
- _____
- _____

Right Leg

- Hip
- Upper Leg Actuator
- Lower Leg Actuator
- Foot Actuator
- JUMP JET
- _____

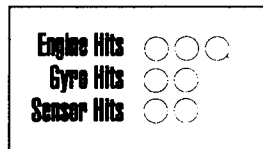

Heat Scale

30	Shutdown
29	
28	Ammo Explosion, avoid on 8+
27	
26	Shutdown, avoid on 10+
25	-5 Movement Points
24	+4 Modifier to Fire
23	Ammo Explosion, avoid on 6+
22	Shutdown, avoid on 8+
21	
20	-4 Movement Points
19	Ammo Explosion, avoid on 4+
18	Shutdown, avoid on 6+
17	+3 Modifier to Fire
16	
15	-3 Movement Points
14	Shutdown, avoid on 4+
13	+2 Modifier to fire
12	
11	
10	-2 Movement Points
09	
08	-1 Modifier to Fire
07	
06	
05	-1 Movement Points
04	
03	
02	
01	
00	

BATTLETECH®

Armor Diagram

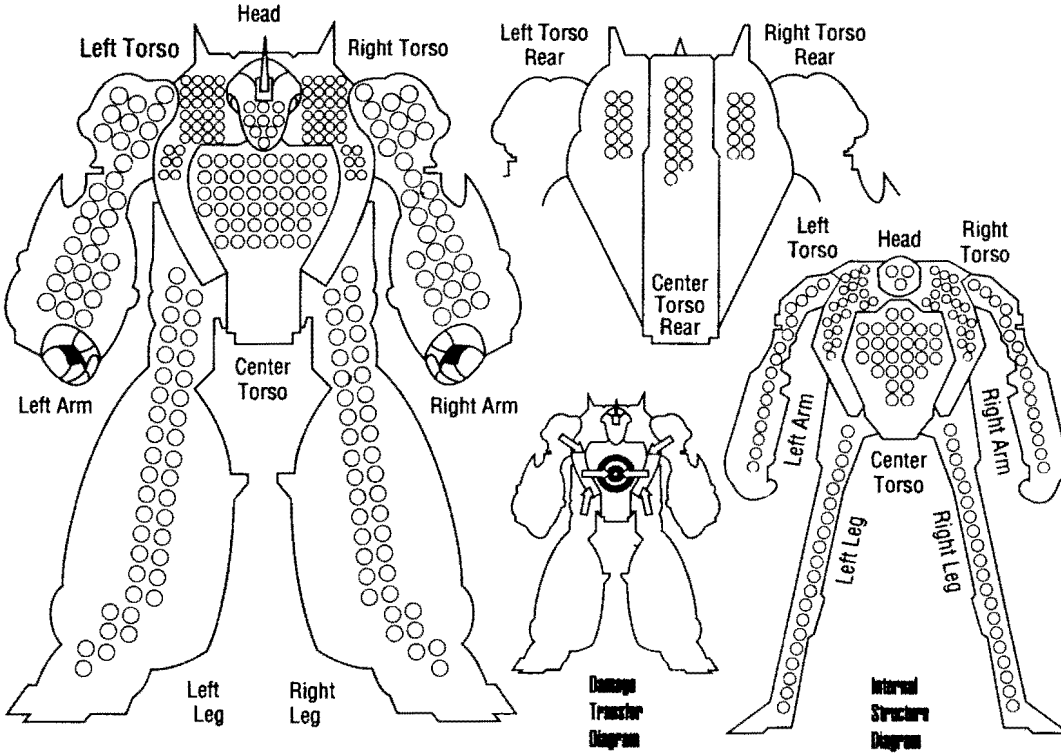

Mech Data

Type: TEMPEST (CLAN)
 Tonnage: 95
 Movement Points: _____
 Walking: 4
 Running: 6
 Jumping: 4

Weapons Inventory

#	Type	Location
1	LG PLS LASER	RA
1	ER LG LASER	RA
1	ER PPL	LA
4	MED PLS LASER	RT, LT
9	ER SM LASER	H, 3x RT, 2x LT

Pod Space: _____
 AMMO: _____
 Auto Cannon Rounds: _____
 M.G. Rounds: _____
 S.R.M. Packs: _____
 Missiles per pack: _____
 L.R.M. Packs: _____
 Missiles per pack: _____

Total Heat Sinks



Warrior Data

Name: _____
 Gunnery Skill: _____
 Piloting Skill: _____
 Hits Taken: (Consciousness Number)
 1st 2nd 3rd 4th 5th 6th
 (3) (5) (7) (10) (11) (Dead)

Left Arm

- Shoulder
 - Upper Arm Actuator
 - Lower Arm Actuator
 - Hand Actuator
 - ER PPL
 - ER PPL
- _____
 - _____
 - _____
 - _____
 - _____
 - _____

Left Torso

- XL
 - XL
 - MED PLS LASER
 - MED PLS LASER
 - ER SM LASER
 - ER SM LASER
- ER SM LASER
 - TARE COMP
 - _____
 - _____
 - _____
 - _____

Left Leg

- Hip
- Upper Leg Actuator
- Lower Leg Actuator
- Foot Actuator
- _____
- _____

Critical Hit Table

Head

- Life Support
- Sensors
- Cockpit
- ER SM LASER
- Sensors
- Life Support

Center Torso

- Engine
 - Engine
 - Engine
 - Gyro
 - Gyro
 - Gyro
- Gyro
 - Engine
 - Engine
 - Engine
 - ER SM LASER
 - ER SM LASER



Right Arm

- Shoulder
 - Upper Arm Actuator
 - Lower Arm Actuator
 - Hand Actuator
 - LG PLS LASER
 - LG PLS LASER
- ER LG LASER
 - ER LG LASER
 - _____
 - _____
 - _____
 - _____

Right Torso

- XL
 - XL
 - MED PLS LASER
 - MED PLS LASER
 - ER SM LASER
 - ER SM LASER
- ER SM LASER
 - TARE COMP
 - TARE COMP
 - TARE COMP
 - _____
 - _____

Right Leg

- Hip
- Upper Leg Actuator
- Lower Leg Actuator
- Foot Actuator
- _____
- _____

Heat Scale

30	Shutdown
29	
28	Ammo Explosion, avoid on 8+
27	
26	Shutdown, avoid on 10+
25	-5 Movement Points
24	+4 Modifier to Fire
23	Ammo Explosion, avoid on 6+
22	Shutdown, avoid on 8+
21	
20	-4 Movement Points
19	Ammo Explosion, avoid on 4+
18	Shutdown, avoid on 6+
17	+3 Modifier to Fire
16	
15	-3 Movement Points
14	Shutdown, avoid on 4+
13	+2 Modifier to fire
12	
11	
10	-2 Movement Points
09	
08	-1 Modifier to Fire
07	
06	
05	-1 Movement Points
04	
03	
02	
01	
00	

BATTLETECH®

Armor Diagram

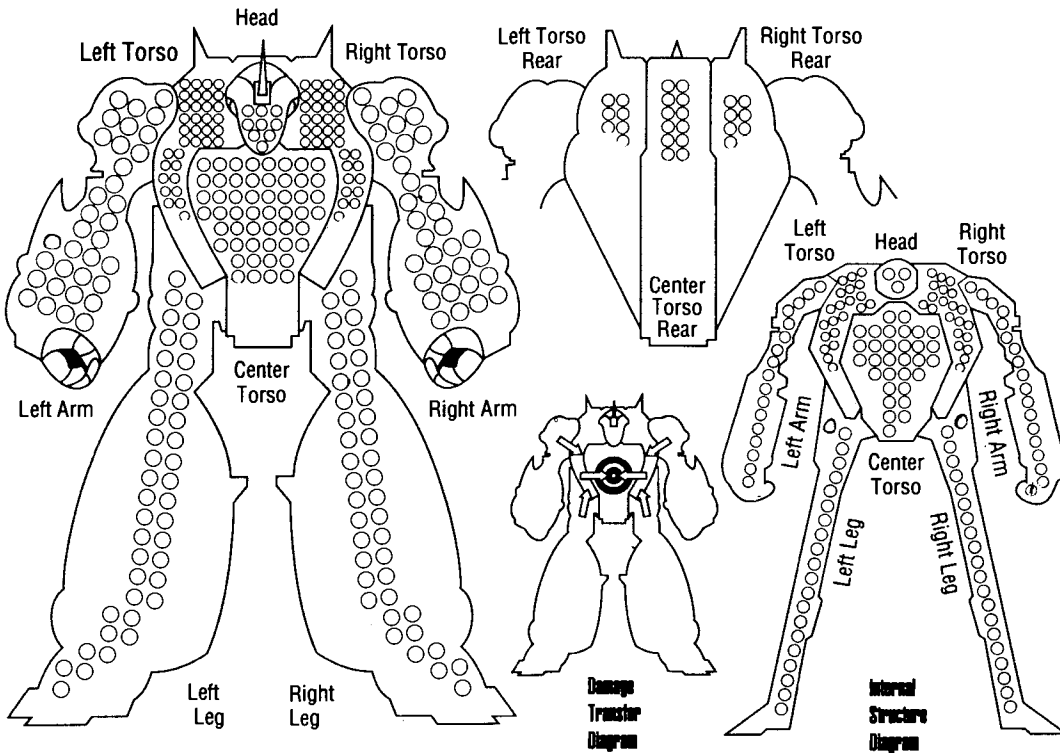

Mech Data

Type: RT-L3R RATTLER
 Tonnage: 100
 Movement Points: _____
 Walking: 3
 Running: 5
 Jumping: 3

Weapons Inventory

#	Type	Location
1	MED LASER	H
86	STREAK-2	SRM/AMMO
20	MG	INTERNAL

Pod Space: _____
 AMMO: _____
 Auto Cannon Rounds: _____
 M.G. Rounds: 400
 S.R.M. Packs: 100
 Missiles per pack: 2
 L.R.M. Packs: _____
 Missiles per pack: _____

Total Heat Sinks

○○○○○○○○○○
 Double

Warrior Data

Name: _____
 Gunnery Skill: _____
 Piloting Skill: _____
 Hits Taken: (Consciousness Number)
 1st 2nd 3rd 4th 5th 6th
 (3) (5) (7) (10) (11) (Dead)

Left Arm

- Shoulder
- Upper Arm Actuator
- Lower Arm Actuator
- Hand Actuator SRM Ammo (50)
- STREAK-2
- STREAK-2

- STREAK-2
- STREAK-2
- STREAK-2
- STREAK-2
- STREAK-2
- STREAK-2

Left Torso

- MG
 - MG
 - MG
 - MG
 - MG
 - MG
- MG
 - MG
 - MG
 - MG
 - MG Ammo (200)
 - (CASE)

Left Leg

- Hip
- Upper Leg Actuator
- Lower Leg Actuator
- Foot Actuator
- _____
- _____

Critical Hit Table

Head

- Life Support
- Sensors
- Cockpit
- MEDIUM LASER
- Sensors
- Life Support

Center Torso

- Engine
 - Engine
 - Engine
 - Gyro
 - Gyro
 - Gyro
- Gyro
 - Engine
 - Engine
 - Engine
 - _____
 - _____

Engine Hits ○○○
 Gyro Hits ○○○
 Sensor Hits ○○○

Right Arm

- Shoulder
- Upper Arm Actuator
- Lower Arm Actuator
- Hand Actuator SRM Ammo (50)
- STREAK-2
- STREAK-2

- STREAK-2
- STREAK-2
- STREAK-2
- STREAK-2
- STREAK-2
- STREAK-2

Right Torso

- MG
 - MG
 - MG
 - MG
 - MG
 - MG
- MG
 - MG
 - MG
 - MG
 - MG Ammo (200)
 - (CASE)

Right Leg

- Hip
- Upper Leg Actuator
- Lower Leg Actuator
- Foot Actuator
- _____
- _____

Heat Scale

30	Shutdown
29	
28	Ammo Explosion, avoid on 8+
27	
26	Shutdown, avoid on 10+
25	-5 Movement Points
24	+4 Modifier to Fire
23	Ammo Explosion, avoid on 6+
22	Shutdown, avoid on 8+
21	
20	-4 Movement Points
19	Ammo Explosion, avoid on 4+
18	Shutdown, avoid on 6+
17	+3 Modifier to Fire
16	
15	-3 Movement Points
14	Shutdown, avoid on 4+
13	+2 Modifier to fire
12	
11	
10	-2 Movement Points
09	
08	-1 Modifier to Fire
07	
06	
05	-1 Movement Points
04	
03	
02	
01	
00	

BATTLETECH®

ARMOR DIAGRAM

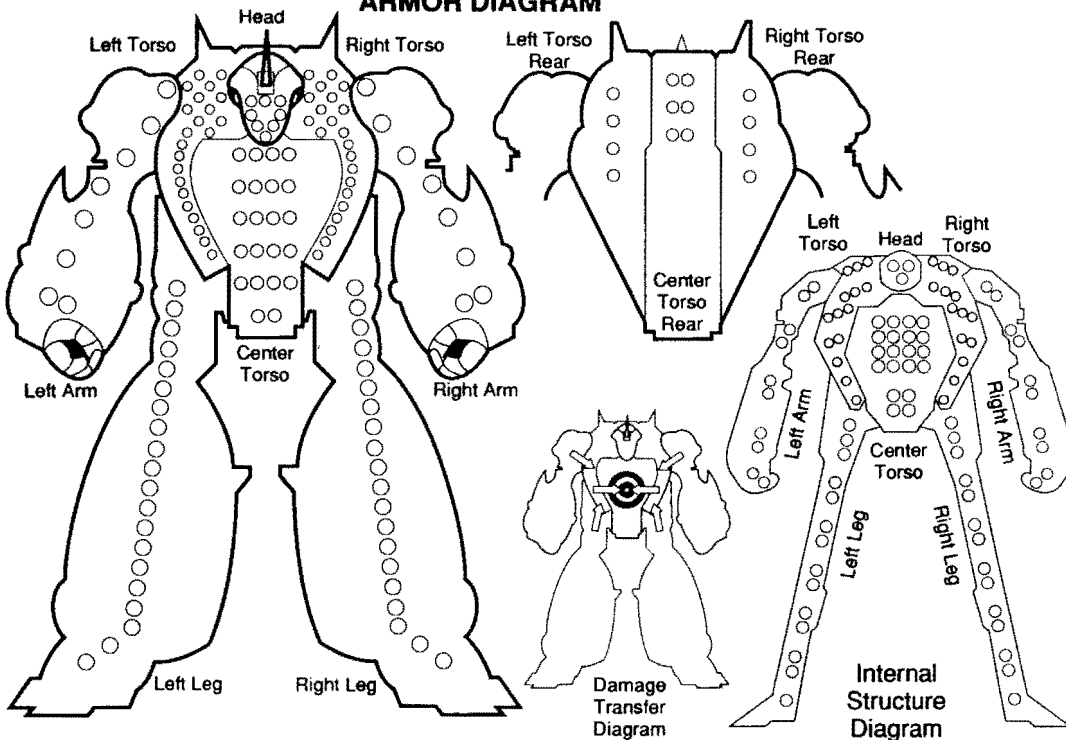

MECH DATA

Type: OSR-2C OSTROC

Tonnage: 60 TONS

Movement Points:

Walking: 5

Running: 8

Jumping: 0

WEAPONS INVENTORY

#	Type	Loc.
1	SRM 4	RT
1	LARGE LASER	RT
1	LARGE LASER	LT
1	MEDIUM LASER	RT
1	MEDIUM LASER	LT

AMMO:

Auto Cannon Rounds: _____

M.G. Rounds: _____

S.R.M. Packs _____ 25

Missiles per pack _____ 4

L.R.M. Packs _____

Missiles per pack _____

TOTAL HEAT SINKS

○○○○○

○○○○○○○○○○

WARRIOR DATA

Name: _____

Gunnery Skill: _____

Piloting Skill: _____

Hits Taken: (Consciousness Number)

1st 2nd 3rd 4th 5th 6th
(3) (5) (7) (10) (11) (Dead)

Left Arm

- Shoulder
- Upper Arm Actuator
- Lower Arm Actuator
- Roll Again
- Roll Again
- Roll Again

- Roll Again
- Roll Again
- Roll Again
- Roll Again
- Roll Again
- Roll Again

Left Torso

- Large Laser
- Large Laser
- Medium Laser
- Roll Again
- Roll Again
- Roll Again

- Roll Again
- Roll Again
- Roll Again
- Roll Again
- Roll Again
- Roll Again

Left Leg

- Hip
- Upper Leg Actuator
- Lower Leg Actuator
- Foot Actuator
- Heat Sink
- Heat Sink

CRITICAL HIT TABLE

Head

- Life Support
- Sensors
- Cockpit
- Roll Again
- Sensors
- Life Support

Center Torso

- Engine
 - Engine
 - Engine
 - Gyro
 - Gyro
 - Gyro
- Gyro
 - Engine
 - Engine
 - Engine
 - SRM 4 Ammo
 - Heat Sink

Engine Hits ○○○○
Gyro Hits ○○○○
Sensor Hits ○○○○



Right Arm

- Shoulder
- Upper Arm Actuator
- Lower Arm Actuator
- Roll Again
- Roll Again
- Roll Again

- Roll Again
- Roll Again
- Roll Again
- Roll Again
- Roll Again
- Roll Again

Right Torso

- SRM 4
- Large Laser
- Large Laser
- Medium Laser
- Roll Again
- Roll Again

- Roll Again
- Roll Again
- Roll Again
- Roll Again
- Roll Again
- Roll Again

Right Leg

- Hip
- Upper Leg Actuator
- Lower Leg Actuator
- Foot Actuator
- Heat Sink
- Heat Sink

HEAT SCALE

30	SHUTDOWN
29	
28	Ammo Explosion, avoid on 8+
27	
26	Shutdown, avoid on 10+
25	-5 Movement Points
24	+4 Modifier to Fire
23	Ammo Explosion, avoid on 6+
22	Shutdown, avoid on 8+
21	
20	-4 Movement Points
19	Ammo Explosion, avoid on 4+
18	Shutdown, avoid on 6+
17	+3 Modifier to Fire
16	
15	-3 Movement Points
14	Shutdown, avoid on 4+
13	+2 Modifier to Fire
12	
11	
10	-2 Movement Points
09	
08	+1 Modifier to Fire
07	
06	
05	-1 Movement Point
04	
03	
02	
01	
00	

BATTLETECH is a registered trademark of FASA Corporation. Copyright 1987. Permission to photocopy for personal use.

The Ostroc: -3 bonus to all piloting skill rolls for falling; -4 kick damage; no piloting skill roll if kick is missed; death-from-above is +5 damage, if possible; -1 to all punch damage; no arm arcs, but can torso twist two hexes.

See Future Wars #26.

BATTLETECH®

ARMOR DIAGRAM

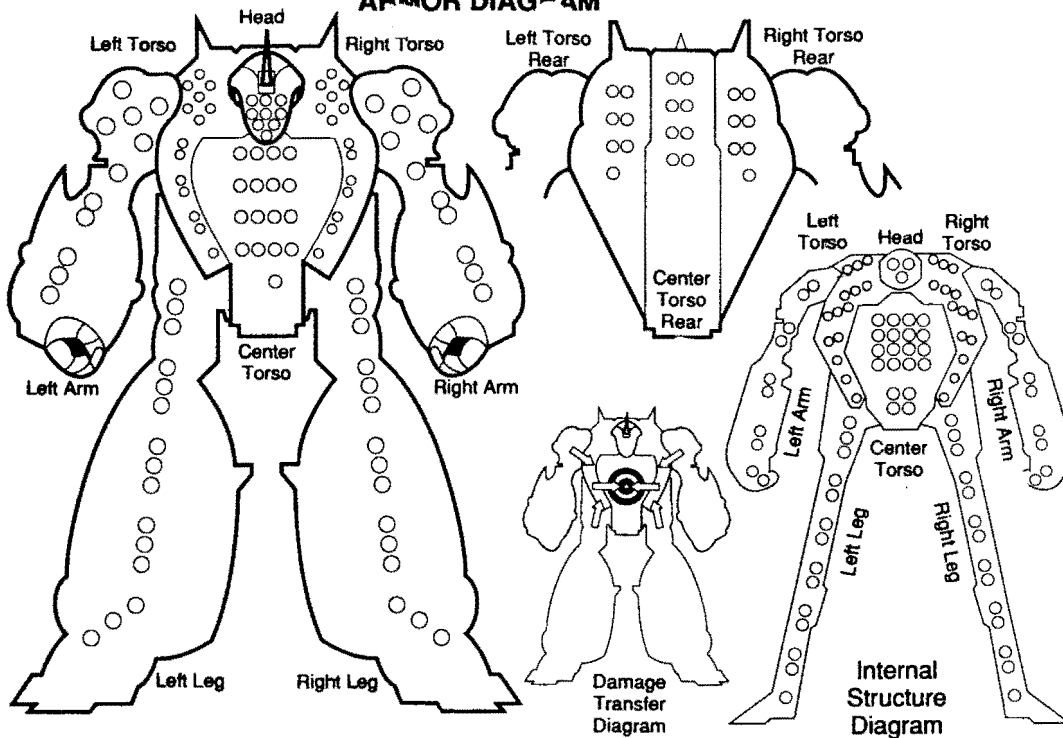

MECH DATA

Type: QKD-4G QUICKDRAW
 Tonnage: 60 TONS
 Movement Points:
 Walking: 5
 Running: 8
 Jumping: 5

WEAPONS INVENTORY

#	Type	Loc.
1	LRM 10	LT
1	SRM 4	CT
1	MEDIUM LASER	RA
1	MEDIUM LASER	LA
1	MEDIUM LASER	RT(R)
1	MEDIUM LASER	RT(R)

AMMO:

Auto Cannon Rounds: _____
 M.G. Rounds: _____
 S.R.M. Packs _____ 25
 Missiles per pack _____ 4
 L.R.M. Packs _____ 12
 Missiles per pack _____ 10

TOTAL HEAT SINKS

○○○
 ○○○○○○○○○○

WARRIOR DATA

Name: _____
 Gunnery Skill: _____
 Piloting Skill: _____
 Hits Taken: (Consciousness Number)
 1st 2nd 3rd 4th 5th 6th
 (3) (5) (7) (10) (11) (Dead)

HEAT SCALE

30	SHUTDOWN
29	
28	Ammo Explosion, avoid on 8+
27	
26	Shutdown, avoid on 10+
25	-5 Movement Points
24	+4 Modifier to Fire
23	Ammo Explosion, avoid on 6+
22	Shutdown, avoid on 8+
21	
20	-4 Movement Points
19	Ammo Explosion, avoid on 4+
18	Shutdown, avoid on 6+
17	+3 Modifier to Fire
16	
15	-3 Movement Points
14	Shutdown, avoid on 4+
13	+2 Modifier to Fire
12	
11	
10	-2 Movement Points
09	
08	+1 Modifier to Fire
07	
06	
05	-1 Movement Point
04	
03	
02	
01	
00	

CRITICAL HIT TABLE

Left Arm	Head	Right Arm
1. Shoulder	1. Life Support	1. Shoulder
2. Upper Arm Actuator	2. Sensors	2. Upper Arm Actuator
3. Lower Arm Actuator	3. Cockpit	3. Lower Arm Actuator
4. Hand Actuator	4. Heat Sink	4. Hand Actuator
5. Medium Laser	5. Sensors	5. Medium Laser
6. Roll Again	6. Life Support	6. Roll Again
1. Roll Again		1. Roll Again
2. Roll Again		2. Roll Again
3. Roll Again		3. Roll Again
4. Roll Again		4. Roll Again
5. Roll Again		5. Roll Again
6. Roll Again		6. Roll Again
Left Torso	Center Torso	Right Torso
1. LRM 10	1. Engine	1. SRM 4 Ammo
2. LRM 10	2. Engine	2. Medium Laser (R)
3. LRM 10 Ammo	3. Engine	3. Medium Laser (R)
4. Jump Jet	4. Gyro	4. Jump Jet
5. Jump Jet	5. Gyro	5. Jump Jet
6. Roll Again	6. Gyro	6. Roll Again
1. Roll Again	1. Gyro	1. Roll Again
2. Roll Again	2. Engine	2. Roll Again
3. Roll Again	3. Engine	3. Roll Again
4. Roll Again	4. Engine	4. Roll Again
5. Roll Again	5. SRM 4	5. Roll Again
6. Roll Again	6. Jump Jet	6. Roll Again
Left Leg		Right Leg
1. Hip		1. Hip
2. Upper Leg Actuator		2. Upper Leg Actuator
3. Lower Leg Actuator		3. Lower Leg Actuator
4. Foot Actuator		4. Foot Actuator
5. Heat Sink		5. Heat Sink
6. Roll Again		6. Roll Again

Engine Hits ○○○
 Gyro Hits ○○○
 Sensor Hits ○○○



BATTLETECH is a registered trademark of FASA Corporation. Copyright 1987. Permission to photocopy for personal use.

The Quickdraw: -2 damage when punching; parry punches with a piloting skill roll, taking 1 point in the parrying arm; arms flip on a +1 piloting skill roll; -2 bonus for all piloting skill rolls for falling; kicks for 9 points; no roll needed if kick missed; +3 death-from-above damage if possible. See Future Wars #26.

BATTLETECH®

ARMOR DIAGRAM

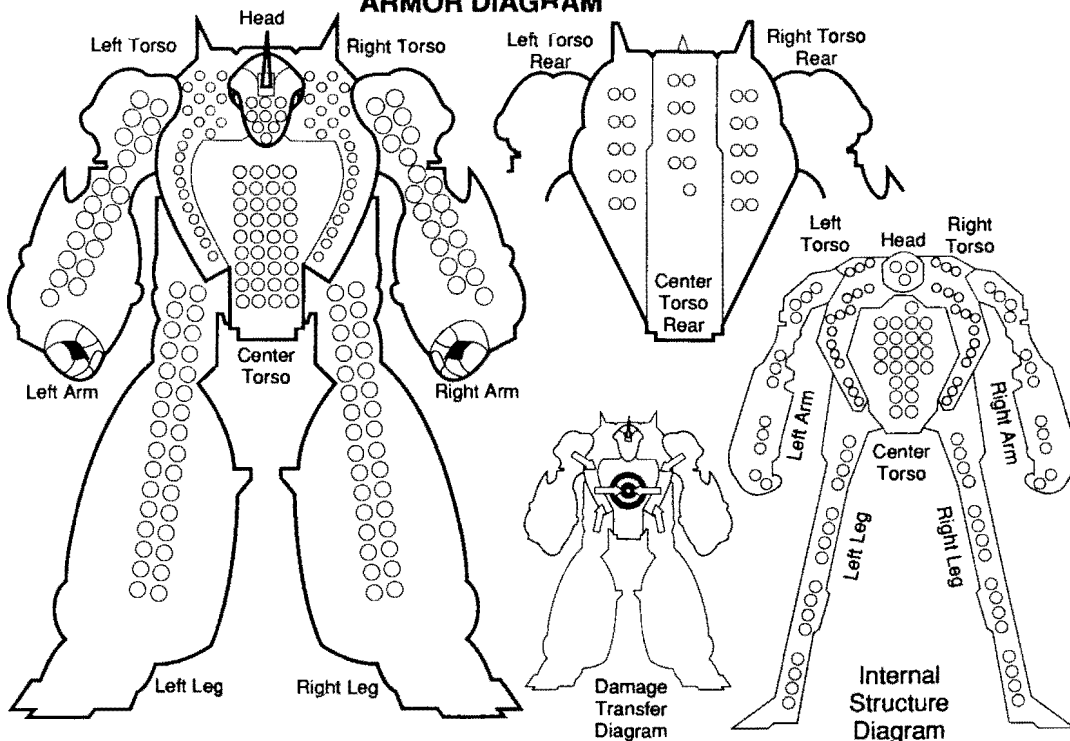

MECH DATA

Type: ON1-K ORION
 Tonnage: 75 TONS
 Movement Points:
 Walking: 4
 Running: 6
 Jumping: 0

WEAPONS INVENTORY

#	Type	Loc.
1	AUTOCANNON/10	RT
1	LRM 15	LA
1	MEDIUM LASER	RA
1	MEDIUM LASER	LA
1	SRM 4	LT

AMMO:
 Auto Cannon Rounds: ___ 20
 M.G. Rounds: _____
 S.R.M. Packs _____ 37
 Missiles per pack. ___ 4
 L.R.M. Packs _____ 16
 Missiles per pack. ___ 15

TOTAL HEAT SINKS

○○○○○○○○○○

WARRIOR DATA

Name: _____
 Gunnery Skill: _____
 Piloting Skill: _____
 Hits Taken: (Consciousness Number)
 1st 2nd 3rd 4th 5th 6th
 (3) (5) (7) (10) (11) (Dead)

Left Arm

- Shoulder
- Upper Arm Actuator
- Lower Arm Actuator
- 1 Medium Laser
- Roll Again
- Roll Again

- Roll Again
- Roll Again
- 2 Roll Again
- Roll Again
- Roll Again
- Roll Again

Left Torso

- LRM 15
- LRM 15
- 1 LRM 15
- LRM 15 Ammo
- LRM 15 Ammo
- SRM 4

- SRM 4 Ammo
- SRM 4 Ammo
- 2 Roll Again
- Roll Again
- Roll Again
- Roll Again

Left Leg

- Hip
- Upper Leg Actuator
- Lower Leg Actuator
- Foot Actuator
- Roll Again
- Roll Again

CRITICAL HIT TABLE

Head

- Life Support
- Sensors
- Cockpit
- Roll Again
- Sensors
- Life Support

Center Torso

- 1 Engine
- Engine
- 3 Engine
- Gyro
- Gyro
- Gyro

- Gyro
- Engine
- 2 Engine
- Engine
- Roll Again
- Roll Again

Engine Hits ○○○
 Gyro Hits ○○
 Sensor Hits ○○



Right Arm

- Shoulder
- Upper Arm Actuator
- Lower Arm Actuator
- 1 Medium Laser
- Roll Again
- Roll Again

- Roll Again
- Roll Again
- 2 Roll Again
- Roll Again
- Roll Again
- Roll Again

Right Torso

- AC/10
- AC/10
- 1 AC/10
- AC/10
- AC/10
- AC/10

- AC/10
- 2 AC/10 Ammo
- 3 AC/10 Ammo
- Roll Again
- Roll Again
- Roll Again

Right Leg

- Hip
- Upper Leg Actuator
- Lower Leg Actuator
- Foot Actuator
- Roll Again
- Roll Again

HEAT SCALE

30	SHUTDOWN
29	
28	Ammo Explosion, avoid on 8+
27	
26	Shutdown, avoid on 10+
25	-5 Movement Points
24	+4 Modifier to Fire
23	Ammo Explosion, avoid on 6+
22	Shutdown, avoid on 8+
21	
20	-4 Movement Points
19	Ammo Explosion, avoid on 4+
18	Shutdown, avoid on 6+
17	+3 Modifier to Fire
16	
15	-3 Movement Points
14	Shutdown, avoid on 4+
13	+2 Modifier to Fire
12	
11	
10	-2 Movement Points
09	
08	+1 Modifier to Fire
07	
06	
05	-1 Movement Point
04	
03	
02	
01	
00	

BATTLETECH is a registered trademark of FASA Corporation. Copyright 1987. Permission to photocopy for personal use.

The Orion: no right-side torso twists; no charges or punches; no arm firing arcs; kicks for 17 points; +1 penalty to all piloting skill rolls to avoid falling.

See Future Wars #26

by Phil DeLuca

Doing this issue was rough. My semester ended in December, and the system I use at home wasn't available (state holiday and all). Besides, the three days it was available, I was packing to come back to good ol' Oneonta State College, set in beautiful upstate New York (depending on who you ask...).

I'm proud of the work this time. When I finally had the time to deal with it steadily, it went faster and

more smoothly than before.

This time around, special thanks go to all the people who helped me: Christine Carter and Michelle Goldberg, for the assistance in typesetting, and Orion Beadling for the last-minute review. Also, thanks go to Thom Elliott for being such a royal pain-in-the-ass! Nothing personal, Thom.

CONVENTION ANNOUNCEMENT: On March 6, 7, and 8, the Gamer's Guild here is hosting OneontaCon III. Registration fees are around \$5, and all sorts of games

will be hosted. The Really Important information, though, is that the Mid-Atlantic BattleTech Championships (New York, New Jersey, Pennsylvania, but all are welcome) are to be held in the same place. Pre-registration fees are \$10, with a penalty for paying at the door, and it is hosted by me, Philip J. DeLuca. For more details, including rules and directions, call (607) 432-3572 and ask for "Phil", or leave a message that includes your name and telephone number, as well as the word "Championships".

As always, send comments and opinions (as well as submissions) about the magazine to me in care of Herb, at the address on the back of the magazine.

FUTURE WARS FOUND HERE!

If your store is not listed here, drop us a note and we'll include it in the next issue possible.

Waterloo Hobbies, Gilbert, AZ
Citadel, New London, CT
Merlin's Bookstore, Tampa, FL
Zeno's Ent, Jacksonville, FL
Just For Fun, Honolulu, HI
Scale Models, South Holland, IL
The Game Room, Washington, IL
The Game Preserve, Indianapolis, IN
Rusty Scabbard, Lexington, KY
Alcove Hobby, Royal Oak, MI
Frontline and Fantasy, Roseville, MI
Hobby House, Westland, MI
RC Hobbies, Pontiac, MI
Riders Hobby, Ann Arbor, Canton, Flint, Grand Rapids, Lansing, Ypsilanti, MI
Raven's Loft, St. Louis, MO
Toy City, Concord, NH
Modular Pegasus, Garwood, NJ
Wargames West, Albuquerque, NM
Adventure and Hobbies, Rochester, NY
Armadillo Games, Rotterdam, NY

Dragon and Dragoon Store, Rochester, NY
Men at Arms Hobbies, Middle Island, NY
The Game Master, Plattsburgh, NY
Waterloo Hobbies II, Williston Park, NY
Dragon's Lair, Dayton, OH
The Guard Tower, Columbus, OH
Tin Soldier, Canterville, OH
Comic Store, West York, PA
Comic Store, Lancaster, PA
Games Unlimited, Pittsburgh, PA
Mr. Fonor's, New Cumberland, PA
Dungeon Books and Comics, San Antonio, TX
Campaign H, Newport News, VA
Eagle and Empire Games, Alexandria, VA
One Eyed Jaques, Richmond, VA
Eagle Games, Bellingham, WA
Napoleon's Shore, Wood, WI
Pegasus Games, Madison, WI
OK Hobby and Games

ONLY \$19?

WHERE CAN YOU GET SO MUCH INFORMATION ABOUT YOUR FAVORITE SCI-FI GAMES FOR SUCH A GREAT VALUE?
HERE, IN
FUTURE WARS.
SIMPLY SEND YOUR SUBSCRIPTION REQUEST AND A CHECK MADE OUT TO "HERB BARENTS" TO
17187 WILDEMERE
DETROIT, MI 48221.
Now.

FUTURE WARS

FUTURE WARS is a magazine that deals mainly with the BattleTech game. Other games, such as **Star Wars**, **Robotech**, and **Renegade Legion** also receive coverage.

Disclaimer:

BattleTech and Renegade Legion are copyrights of FASA
Space 1889 and Twilight: 2000 are copyrights of GDW
Robotech is a copyright of Palladium
Star Wars (the game) is copyright of West End Games
Silent Death is copyright of Iron Crown Enterprises.

None of the articles in **FUTURE WARS** are sanctioned, approved or otherwise supported by any of the above-mentioned companies, **FUTURE WARS** has not been authorized to produce any rules, or changes to any rules, by the above-mentioned companies. Rather, **FUTURE WARS** and the authors of the articles are solely responsible for the contents herein. The use of the names in the articles are used *without* the permission and consent of the holders of the applicable copyrights and trademarks.

FUTURE WARS is issued bimonthly. Subscriptions are available at \$19 for 6 issues. **FUTURE WARS** is issued in even numbered months. Send subscriptions via check or money order payable to:

Herb Barents
17187 Wildemere
Detroit, MI 48221

Do not send cash through the mail!

FUTURE WARS needs contributors. This means YOU, the reader. When your article or artwork appears in an issue, you get that issue, and a Ral Partha BattleMech miniature free. Letters to the editor, if printed, do not receive these items.

Special thanks again to Ral Partha for supplying us with the miniatures used to pay our authors and artists for their contributions.

Thanks to our authors, because without your help and support this 'zine would not have made it for almost five years.

FUTURE WARS

c/o HERB BARENTS
17187 WILDEMERE
DETROIT, MI 48221
(313) 863-7321
(313) 861-6565 FAX

3RD CLASS MAIL

TO: