

the **CAR WARS** magazine

Vol. 3, No. 4

\$3.00

# Autoduel Quarterly

THE JOURNAL OF THE AMERICAN AUTODUEL ASSOCIATION

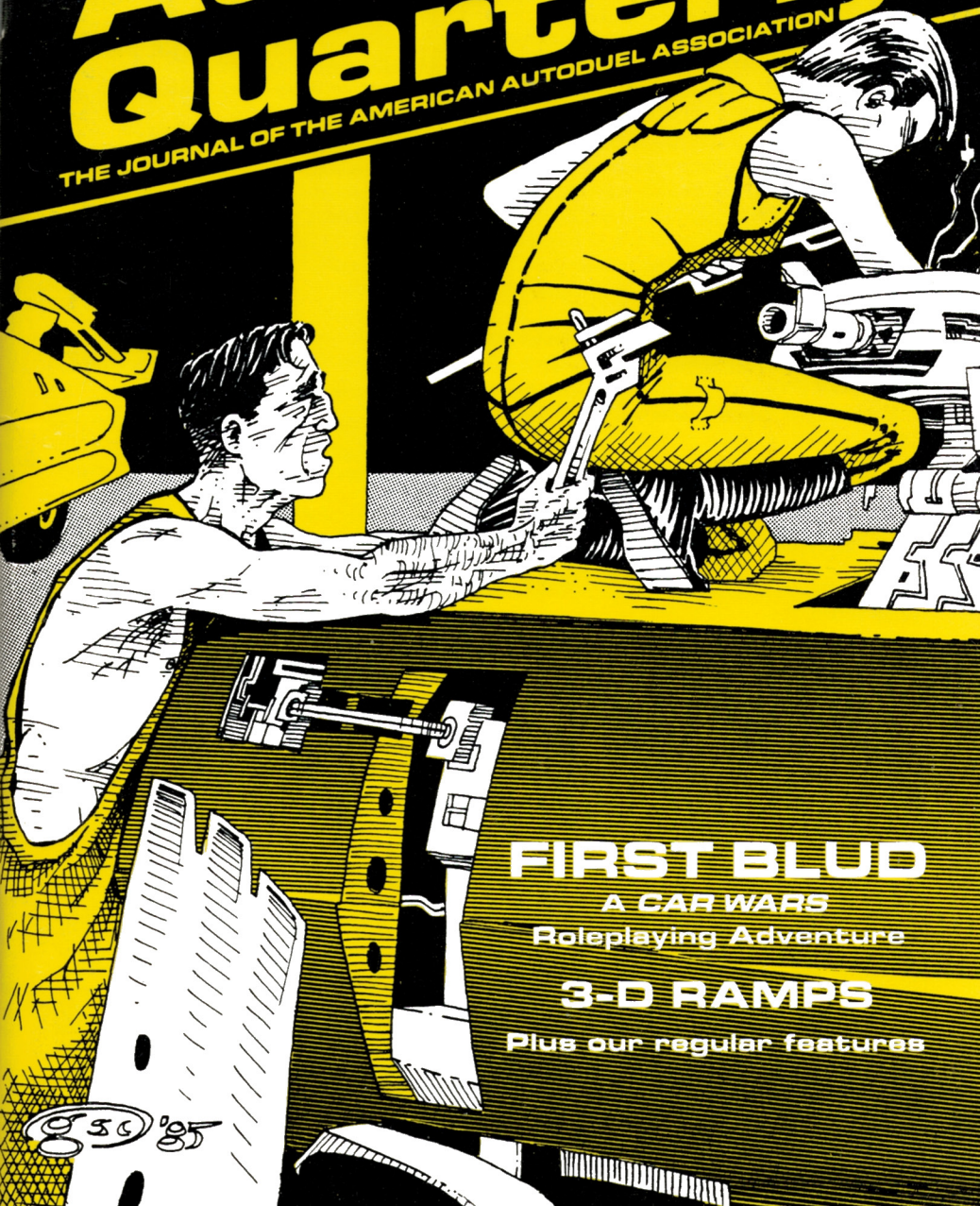

**FIRST BLUD**

A **CAR WARS**  
Roleplaying Adventure

**3-D RAMPS**

Plus our regular features

© 30 '85

# SJ GAMES ORDER FORM

SUBSCRIPTIONS — Please circle desired rate:

	<i>4 issues</i>	<i>8 issues</i>	<i>12 issues</i>	<i>Lifetime</i>
<i>Autoduel Quarterly</i>	\$10	\$20	\$30	\$100

Check here if this is a subscription renewal. Please add 50¢ per issue for Canadian addresses, and \$1.00 per issue for addresses outside the U.S. and Canada. All copies are sent surface mail.

- CAR WARS® DELUXE EDITION — 64-page rulebook, 300 counters, three maps, and Deluxe Road Sections in a 9" x 12" box ..... \$18.50 \_\_\_\_\_
- CAR WARS — Cycles and autos battle on the highways! (Pocket Box) ..... \$6.50 \_\_\_\_\_
- CRASH CITY™ — (New title) Midville MONDO motorcycle mayhem. (PB) .. \$6.50 \_\_\_\_\_
- TRUCK STOP™ — 18-wheelers and other large vehicles for *Car Wars*. (PB) .. \$6.50 \_\_\_\_\_
- UNCLE ALBERT'S™ 2035 CATALOG — Gadgets and weapons from the autoduel dealer ..... \$4.50 \_\_\_\_\_
- CONVOY® — A programmed adventure for *Car Wars* ..... \$6.50 \_\_\_\_\_
- CAR WARS EXPANSION SET 1 — More and different roads and counters .... \$4.50 \_\_\_\_\_
- CAR WARS EXPANSION SET 2 — Duplicate counters plus turning key ..... \$4.50 \_\_\_\_\_
- CAR WARS EXPANSION SET 3 — East Midville:  
two giant maps, counters, scenarios ..... \$4.50 \_\_\_\_\_
- CAR WARS EXPANSION SET 4 — Armadillo Autoduel Arena:  
32" x 42" arena, counters, scenarios ..... \$4.50 \_\_\_\_\_
- CAR WARS EXPANSION SET 5 — Double Arena:  
two new *Car Wars* arenas, and 24 vehicle counters ..... \$4.50 \_\_\_\_\_
- CAR WARS EXPANSION SET 6 — *The AADA Vehicle Guide* Counters:  
Four counter sheets — with wrecks on the back! ..... \$4.50 \_\_\_\_\_
- CAR WARS EXPANSION SET 7 — Off-Road Duelling:  
Two full-color 21" x 32" maps and 30 counters ..... \$5.50 \_\_\_\_\_
- CAR WARS EXPANSION SET 8 — Chopper Challenge:  
Two full-color 21" x 32" maps and 19 counters for copter combat ..... \$5.50 \_\_\_\_\_
- DELUXE ROAD SECTIONS — Durable high-quality highways  
Set 1: Starter Set — Complete track layout plus 116 counters ..... \$4.50 \_\_\_\_\_  
Set 2: Intersections — Turnouts, crossroads, straights, 46 counters ..... \$4.50 \_\_\_\_\_  
Set 3: Straights — Nine straight sections plus 27 counters ..... \$4.50 \_\_\_\_\_
- CAR WARS MAP SHEETS — Temporarily out of print ..... \$5.50 \_\_\_\_\_
- THE AADA VEHICLE GUIDE — Over a hundred vehicles, completely described \$6.50 \_\_\_\_\_
- CAR WARS REFERENCE SCREEN — Charts, index, design sheets, etc. .... \$5.50 \_\_\_\_\_
- AUTODUEL® CHAMPIONS POSTER — 17" x 22" poster from the game cover \$1.50 \_\_\_\_\_
- AUTODUEL — Origin Systems' computer game for the Apple ..... \$52.00 \_\_\_\_\_

Payment is by: \_\_\_\_\_ Texas residents add 5 1/8% sales tax (on all items) \_\_\_\_\_  
 check    money order    MasterCard    Visa   Total enclosed \_\_\_\_\_

Name \_\_\_\_\_ Address \_\_\_\_\_

City \_\_\_\_\_ State/Prov \_\_\_\_\_ Zip \_\_\_\_\_

(Credit orders): Acct. no. \_\_\_\_\_ Date exp \_\_\_\_\_

Signature \_\_\_\_\_

Prices includes postage and handling. Payment must be in U.S. dollars on a U.S. bank. All subscriptions start with the next issue published. Make checks payable to Steve Jackson Games. Send to:

**STEVE JACKSON GAMES**  
 Box 18957-T, Austin, TX 78760

Vol. 3, No. 4  
Winter 2035

# Autoduel Quarterly



## STAFF

### Editor

*Scott D. Haring*

### Assistant Editors

*Jim Gould*

*Allen Varney*

### Publisher

*Steve Jackson*

### Editor-in-Chief

*Warren Spector*

### Production Staff

*C. Mara Lee*

*Kyle Miller*

*Melissa Snell*

### Business Manager

*Mark Chandler*

### Circulation Manager

*Creed Lambard*

### Art in this issue:

*Glenn A. Austin*: 37, 38, 39, 40, 41, 42. *Graham Chaffee*: front mailer, front cover. *Brian Gibson*: 26, 19. *C. Bradford Gorby*: 30, 48. *C. Mara Lee*: 17. *Kyle Miller*: 4, 5, 7, 8, 11, 14, 32, 33, 45, back cover. *Mike Surbrook*: 44. *George "Speed" Webber*: 3, 29, 31, 35, 47.

### Trademark Notice

*Car Wars*, *Truck Stop*, *Convoy*, and *Autoduel* are registered trademarks of Steve Jackson Games Incorporated. The AADA and names of other games published by Steve Jackson Games Inc. are trademarks of Steve Jackson Games Inc., or used under license.

## CONTENTS

### ADQ Custom Feature

*Jeffrey Field* ..... 6

### Checker's Pizza — We Deliver

*Brian Upton* ..... 8

### Excerpts from the North American Road Atlas and Survival Guide, 3rd Edition: CUMBERLAND, MARYLAND

*Greg Porter* ..... 15

### First Blut/A Car Wars Roleplaying Adventure

*Scott Haring* ..... 18

### Racetrack Arenas

*Scott Haring* ..... 28

### Ramps in Car Wars

*Glenn A. Austin* ..... 26

## DEPARTMENTS

The Driver's Seat / *Scott Haring* ..... 2

Newswatch / *Scott Haring* ..... 3

AADA News ..... 34

ADQ&A / Questions and Answers ..... 43

Backfire / Letters ..... 46

## ADVERTISERS

AADA ..... inside front mailer

Atlantic Industries ..... back cover

Atlas Body Works ..... 32, 33

Courier Motors ..... 45

Origin Systems, Inc. .... 27

Steve Jackson Games ..... inside front cover, inside back cover

Uncle Albert's Auto Stop and Gunnery Shop ..... 4, 5

### Designs in this issue:

*Peter Dosik*: 33. *Scott Haring* (Incendiary Ammo): 4, (Portable Fire Extinguisher): 5, 45, back cover. *Charles S. Mote, Jr.*: 32. *Pat Rogers* (Fifth Wheel Guard): 5. *Craig Sheeley* (Thermite Limpet Mine): 4.

*Autoduel Quarterly* (ISSN 0740-3356) is published quarterly by Steve Jackson Games Incorporated, 2700-A Metcalfe, Austin, TX 78741. Please address all correspondence to Steve Jackson Games, Incorporated, P.O. Box 18957, Austin, Tx 78760-8957. "Winter 2035" issue published December 1985. Second-class postage paid at Austin, TX. POSTMASTER: Send address changes to *Autoduel Quarterly*, P.O. Box 18957, Austin, TX 78760-8957. All material is copyright © 1985 by Steve Jackson Games. All rights reserved. Subscription rates as of March 15, 1984 — In the United States: 4 issues \$10 (Texas residents please add 51¢ tax). Outside the US: please add 50¢ per issue for Canada, \$1 per issue for foreign surface mail. International rates are subject to change as postal rates change. NOTE: All payments must be in US dollars, made by International Money Order or check drawn on a US or Canadian bank.

## the Driver's Seat

I don't have much space, so it's just odds and ends this issue . . . the last one in our third year. It's been the biggest and best year yet, and I don't see anything in the future that will slow us down. The submissions continue to get better and better — both in subject matter and presentation. For a while there, I was wondering what kind of English they taught in school today. But I've seen a good bit of improvement, even in grammar and spelling. So, keep it up! If you have an idea that you think will improve the game, send it in! Don't forget a self-addressed, stamped envelope, so I can get word back to you on the article and/or return it if we can't use it.

Which brings me to the subject of correspondence. I thought that asking everyone to include a self-addressed, stamped envelope with their letters would do two things: It would save us a lot of money on postage, and it might cut down on the number of letters I had to answer. Well, I was only half right — it's certainly saved us a lot of postage. Unfortunately, the volume of mail has, if anything, increased. I appreciate the interest, I really do — but I don't have enough time. The six weeks or so that I answered every letter faithfully the day I got it, I got nothing else done. I've started passing some of the easier letters on to Allen Varney, but it's not the ultimate solution. I'm going to have to ask you to cut down on your letters that require answers. There are some of you who have become regular correspondents, practically. If you want to keep sending letters, please do. I love reading them, and will print the best parts in *Backfire*. But I just can't answer them all.

The other kind of letter I'm getting too many of is rules questions. Many of the questions involve odd combinations of equipment and situations: "Can you roller skate through oil?" "What happens if a helicopter is directly overhead when an ejection seat is fired?" "Can landing in a pillow factory reduce the damage of a fall?" Etc., etc. Obviously, the weird combinations of extraordinary circumstances

and players' creativity is infinite. There is *no way* we can come up with "official" rules answers to cover all these situations. There is no way we should be expected to. The answer to all the above questions, and the million-and-one like them, is simply, "*Let your referee decide.*" That's what referees are *for*, for Fangio's sake. So, please — no more "roller skate" questions.

Now, I know our rules aren't perfect (boy, do I know that!) . . . if you have a legitimate rules question, send it in. If it's really good, it'll show up in ADQ&A. If you need a personal reply, include an SASE. But please keep the questions short, and make the answers short, too. Questions that begin with the word "Why" do not make for short answers. We don't have concrete technological foundations for every rule in the game (as some of you have gone to painstaking lengths to point out) — don't ask us to justify them. Please make no comparisons between the performance of game equipment with modern-day military hardware. We never said they were related. Remember, it's a game — a science fiction game, at that.

Back issue update: *ADQ 2/4* is now out of print. The only back issues that are available are 3/1, 3/2, and 3/3. They're available direct from us at our regular address: Steve Jackson Games, Box 18957, Austin, TX 78760. The price is \$3.50, which includes postage and handling, per issue. Texas residents please add 5 1/2% sales tax.

I think you'll like this issue. Big League Unlimited Duelling's cowardly attack on unsuspecting (and practically unarmed) AADA members in Kansas City has been well documented — now you can play it out for yourself. This issue's fiction piece puts a 2035 update on a traditional automotive occupation. And definitely check out the article on 3-D road sections. When I saw them at GenCon, I was amazed, and the designer/builder agreed to share his secrets with us. You'll love it!

I'm trying to track down a few contributors to back issues of the magazine whose addresses I have lost. I'm looking for David DeHay, Phil Tortorici, and Paul Harralson. I have contributor's checks and free copies of the issue your work appeared in for all of you, but you have to get in touch with me. Please write.

Well, that's all I've got room for. Keep On Duellin'!

—Scott D. Haring



---

# NEWSWATCH

---

## History of Kane Motors

- 2024: Absalom Kane starts his first design — the Sargasso. After trying to get backing for the project for most of the year, he is finally successful. Kane Motors' first car rolls off the line.
- 2025: The Sargasso becomes the hottest selling subcompact on the market (probably because it is the only mass produced duelling model available). Kane starts designing his second car — the Max 2.
- 2026: Again Kane Motors heads the sales figures, as the Max 2 sets records for the most sold in one year.
- 2027: A disastrous year. Absalom Kane is killed in a 15-car accident. Due to a freak mishap, his clone has gaps in its memory, and a court rules that it is not Absalom Kane. The company is taken over by John Kane, Absalom's son. Sales of the Sargasso and the Max 2 decline slightly as other models come onto the market.
- 2028: Another bad year. Kane's first van-sized car released onto the market. Result: total failure. Named the Superfort, it was over-armed and under-armored. After six months, it was removed from production.
- 2029: Kane returns to compact design, producing the Firehawk.
- 2030: Kane experiments with station wagons, eventually releasing the Rockwell. Kane stock starts to recover.
- 2031: The Slingshot van is designed and produced. The critics, expecting it to be another Superfort, are proved wrong by the sales in the first months.
- 2031: The release of the Superflash coincides with "Madman" Pirelli's attempt on the North American Unlimited finals. This is the first high-ticket car in the Kane line, and even with the high price, many are sold. There is a resurgence in the sales of the Sargasso and the Max 2. Kane makes a deal with Adrienne Horowitz to mass produce the Moose.
- 2033: Moose released. The production of the Firehawk is cut back and then scrapped altogether. Other models still selling well.
- 2035: Kane produces a limited edition car called the 'Brand.' Only 5000 are made and over half of them are ordered before one rolls off the line.

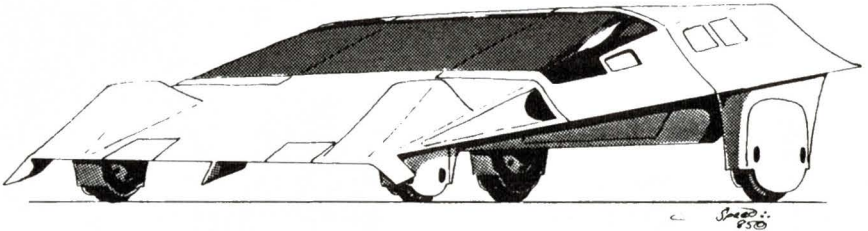

## 50 Years Ago Today

### Trucker said to fire air gun at car

A truck driver allegedly used an air gun connected to his semi-trailer's air brakes to shoot out the windows of an automobile that cut in front of him, state Highway Patrol troopers said.

Thomas Brown, 44, of Forestport, N.Y., was being held in the Ashland County Jail yesterday after being charged with improperly transporting a firearm. Troopers said they also found a 9mm pistol in the cab of his truck.

A car reportedly cut in front of Brown's truck just before he entered a one-lane construction area on Interstate 71 late Friday. Brown allegedly used the air gun to shoot pellets at the car, shattering the driver's window and a side window, police said.

None of the four Cleveland area men in the automobile was injured.



# UNCLE ALBERT'S

## UNCLE ALBERT IS PLAYING WITH FIRE!

But it's your opponents who'll get burned when you use the latest from Uncle Albert!

### *Incendiary Ammo*

This latest beauty from Uncle Albert's Weapon Research Division is based on a simple principle — why give your opponent one thing to worry about when you can give him two? Not only do these slugs chew up armor with the best of them, but they can also start a vehicular fire that will bring your duel to a quick and satisfactory end. Add another dimension to your fighting with Uncle Albert's Incendiary Ammo!

Incendiary Ammo — Costs 15 times as much as regular ammo, weighs the same. Available for MGs, VMGs, and tripod-mounted MGs only. Does normal damage to regular or reflective armor, one point less to fireproof armor. Does normal damage to pedestrians and internal vehicular components. Starts fires like a flamethrower, that is, if 10–24 points of damage are given in one turn, target has 2 in 6 chance of catching fire; 3 in 6 if 25 or more hits are given; and if the power plant, flamethrower, or flaming oil jet is hit (by any amount of damage), 4 in 6 chance. If a vehicle with a weapon using Incendiary Ammo is on fire, there is a chance the vehicle will explode just as if the vehicle had other volatile weapons (rockets, flamethrowers, etc.). If the variant fire rules are being used, the Incendiary Ammo has a burn modifier of 2 and a burn duration of 1.

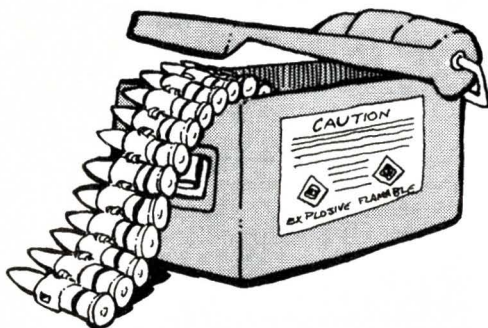

### *Thermite Limpet Mine*

The limpet mine has long been a favorite item for pedestrians who like to leave their surprises for when they're not around. Now, Uncle Albert makes it a *really* hot item . . . Blast 'em and burn 'em with the new thermite limpet mine!

Thermite Limpet Mine — Identical in all ways to the standard limpet mine, except for cost — \$80. When it goes off, it does standard damage (1d+1). In addition, the damage is treated like flamethrower damage for the purpose of setting the vehicle on fire (since it takes at least 10 points of flamethrower damage to set a fire, it will take at least 10 points of limpet mine damage — necessitating at least two thermite limpet mines). If the variant fire rules are being used, the thermite limpet mine has a burn modifier of 3 and a burn duration of 1.

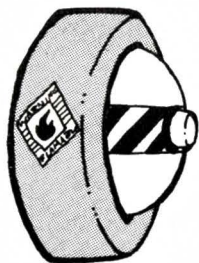

# AUTO STOP & GUNNERY SHOP

## *Portable Fire Extinguisher*

Didn't have the bucks or the weight for an inboard fire extinguisher? Welcome to the club. And now that you've started to prosper, a retrofit doesn't seem right, either. Uncle Albert has the solution! This portable fire extinguisher can be carried in your cargo area and brought out in emergencies, and can also be carried by a pedestrian — and you don't have to be told how convenient *that* could be! Fire is the duellist's number one enemy — beat it with Uncle Albert's Portable Fire Extinguisher!

Portable Fire Extinguisher — \$150, 20 lbs., ½ space as cargo, 3 grenade-equivalents when carried. Puts out a vehicular fire on a 1-2 on a six-sided die. Can be "fired" 20 times before it must be recharged — which costs \$20 and can be done at many truck stops, armories, and hardware stores.



## *Fifth Wheel Guard*

The second most precious thing to a trucker is his cargo. Lose it, and kiss your payoff goodbye. And what keeps a trucker connected to his precious cargo? The fifth wheel, of course. And it only makes sense that a trucker make that connection as solid and secure as possible. That's why Uncle Albert now has a Fifth Wheel Guard, guaranteed to help protect that vulnerable fifth wheel from hijackers trying to separate you from your payday. And only from Uncle Albert's!

Fifth Wheel Guard — Costs \$15 and weighs 10 lbs. per point of armor. 20 points of armor is the limit. Completely protects the fifth wheel, and does not interfere with special kingpin functions. A tractor-trailer rig with a Fifth Wheel Guard may not perform a maneuver of greater than D3 difficulty.

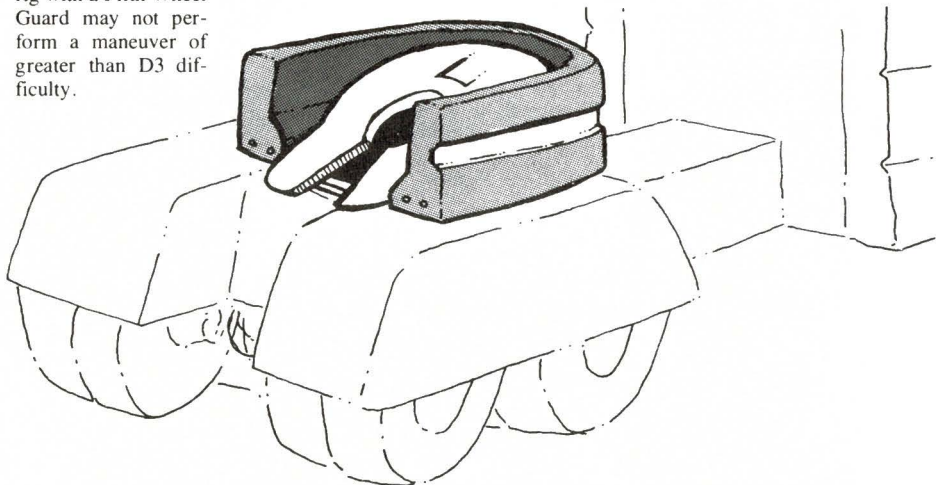

# McCarthy Family Part of Powersaw's Success

by Jeffrey Field

*Assigned to do the Chris "Powersaw" McCarthy interview, I visited his old family homestead. When I arrived, however, I found instead an unusual individual who gave to me a unique view of the Saw's autodueling history. The Powersaw McCarthy interview can be found elsewhere in numerous television replays. What follows is the time spent with his father, Scats McCarthy, while we waited for the Saw.*

As soon as the chopper settled, I stumbled out, leaving Fletcher to power down the bird. The day was overcast and turbulent, my stomach clammered threateningly for solid ground. Up in the hills, the clouds hung low, shredding themselves on the treetops. Mist sifted through the sparse undergrowth and a palpable gloom seemed to peer from the deep woods. The air sat in my lungs, sweet and damp.

In the three cleared acres around us sat two large houses and numerous barns, sheds, and garages. On the porch of the older house, a grizzled man leaned against a pillar and watched me slog across the front yard. Dressed in flannel and denim, he sucked a pipe and fingered his ragged beard. I placed him at about fifty years, and hoped he wasn't senile.

"You're early," he said suddenly, by way of greeting, "ain't no one else here."

I hadn't yet warmed up the journalistic charm, and all I managed was an "Oh."

The oldestster peered at me, then reached into his hip pocket. "Don't matter," he said, "come sit and we'll wait. Want a chew?" He held out a plug of tobacco, and when I declined, he bit off a chunk for himself and put the pipe back in his mouth.

I wandered up and sat on the damp stairs. From the back of the porch, an immense dog growled at me, but refused to leave her suckling pups.

"You're here to see little Christian, ya?" I nodded. Chris McCarthy is 6 foot 4 and weighs 250.

The old guy puffed his pipe, then paused to spit. "Well, I'm his pa. Name of Scats. Christian's out with the family, sorta welcome home thing." He waved his pipe towards the woods. The deep woods.

I looked the man over again. He still looked weathered and senile. Behind the house, chickens clucked. "You're his father?"

Scats grinned, exposing brown teeth. "That's what his ma says, anyhow. And the other five all look like him, so's I'm inclined to believe her."

"Powersaw has brothers?" I asked, thinking of a possible up-and-coming scoop.

McCarthy pulled at his beard. "Well, one, but Grant, he died the other fall, careful how you use his name around the others. No, mostly Christian's got sisters. Four of 'em."

"And where are they?" Maybe Fletcher, who doubled as my cameraman, could get some good pictures.

"Why, they're out with their ma and the rest of the family. Damn joyriding." He looked wistfully to the west and waved his pipe again. Towards the deep woods.

I stared dubiously into the gloomy depths. The trees grew packed together, with underbrush tangled at their bases. "Joyriding? What, on bikes?"

"Ya, sure. Bikes, trikes, trucks. They took nearly everything but little Christian's Stump Jumper. Me, I bummed my wrist and can't work the sticks. So they left me behind with the youngest; they're down for their nap right now. Big night tonight."

"Why, what's tonight?"

"Told you, Christian's welcome home thing. Now that he's back, we're gonna take some Doland toll."



Somewhere between the tobacco and the pipe, his words were losing sense. "Some what?" I asked.

"Dolands. Last fall, some of their boys shot up young Grant. Watch how you use his name around here, see, they jiggered him and now them Dolands are gonna pay. We been waiting for Christian, since he always was real close to young Grant."

Fletcher was out with his camera, shooting footage. It occurred to me that I should be taking notes. McCarthy spit and puffed, and his fist clenched down on the pipe briefly.

"So this is something of a clan feud?" I pried.

Old McCarthy sighed, then knocked his pipe out. As he blew the stem clear, he pulled out of his mood. "Feud? No, just family business."

"The whole family?" I was, well, surprised. "His sisters, too?"

McCarthy looked at me, confused. "Sure. Can't women hate the Dolands? This here's America.

"Look, kid. When the boys start getting big in their britches and the girls stretching their shirts, well, then we take them out and leave 'em in the woods with a bike. Everyone does it, so we're all equal, see?"

"Alone, in the woods?" My voice cracked.

"Oh, it's mostly show, really. No one never made it. If they survived to that age, they can do it. If you know the woods, they'll treat you right in return."

I was blatantly astonished and I suspect my mouth hung open. Scats scratched his beard, then turned to look at me. "Ever been in a road duel, kid?"

"Yeah, sure," I muttered, thinking back to the time I'd unwittingly become a gunner in the news van.

"Fun, weren't it?" Scats gazed off into the trees and grinned, apparently recalling some particularly joyous dustup. Then he spat and looked at me coldly. "Out here, it's different. A man fights for his family and his life, and it's the terrain that's your worst enemy. Folks like the Doland boys are just added topping. Yep, them woods will kill you.

"But you learn to live with them, then you learn to love 'em. Them woods, they get into your system. You always gotta go back in.

"Like now. Little Christian's out there warming up on Bethany's bike, but tonight he's taking the Stump Jumper in, and I'm gonna



be his gunner. The woods getcha that way, you can't quit." He stared at me from under grey brows, and I realized those clear eyes were far from senile.

For the first time, I looked into the woods, instead of at them. Within the cool dusk and seductive mists, I imagined I could see the young Powersaw McCarthy riding his bike amongst the trees. Riding where trunks loomed and the ground bucked underneath him. To the Saw, road duels were dessert. He'd grown up where opponents were spice to the real challenge. Cream skimmed from the top.

The sound of motors buzzed through the woods. Scats punched my arm and grinned. "There they are. Nice sight, my family, ain't they?"

A dozen bikes and trikes and a few pickups, all jacked up and riding mud slingers, flickered amongst the trees. The trucks bounced around the trunks, and the bikes, bright flashes of color in the dark woods, jumped and spun. One of the trikes let off a greeting burst of gunfire and Scats waved his arm.

In the lead of the humming, jostling pack rode a pair of bikes. In tandem precision they flew over a log and skidded to a stop in the clearing. On one bike I recognized the hulking frame of Powersaw McCarthy.

Scats stood on the porch, chewing on his empty pipe. His weathered face scrunched into a wide grin. He punched me in the arm again. "That there's Christian," he beamed, "and the other one's my pa."

Something inside me said I'd be coming back to these deep woods.

# Checker's Pizza — We Deliver

by Brian Upton

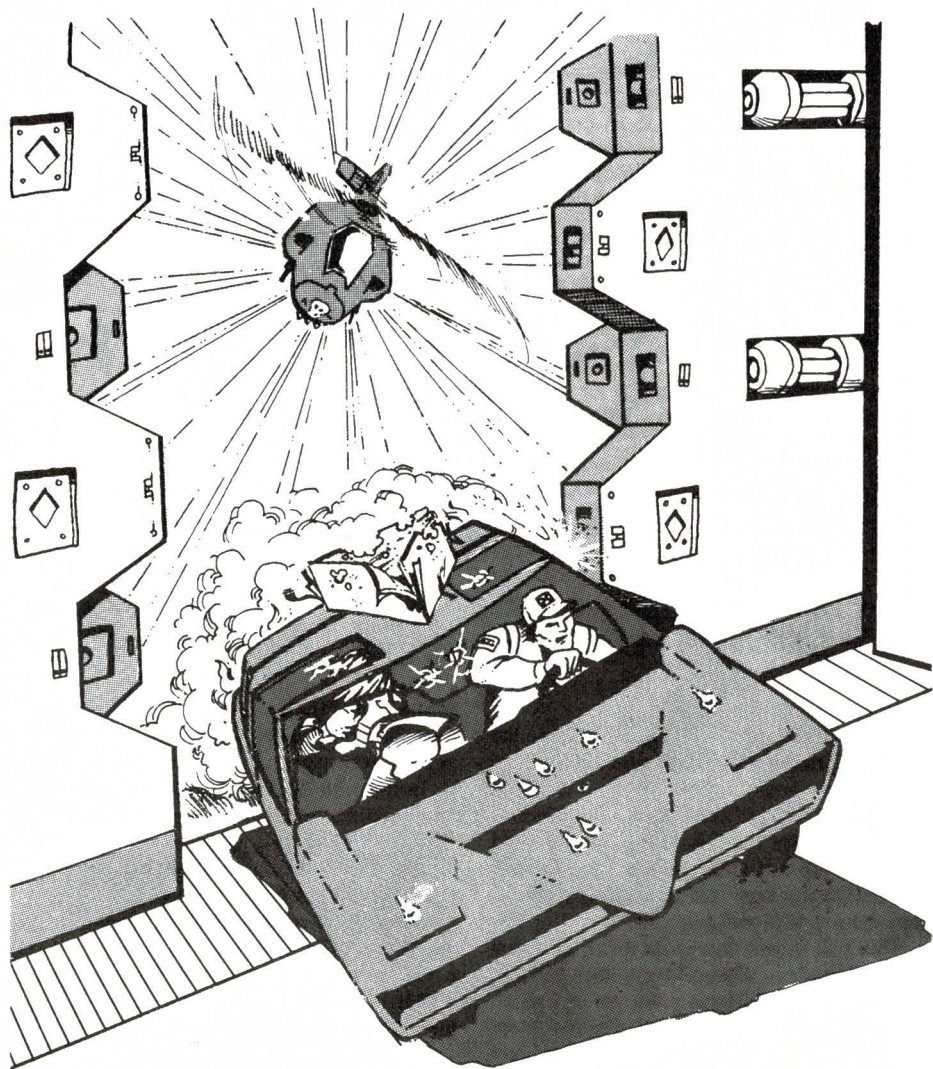

I could tell things were going to pieces between Lydia and me. We spent our last afternoon together arguing with each other while she tuned and loaded the ferocious old Monte Carlo she used to wheel around in — a huge clunker, a relic of the old internal combustion days with the V-8 ripped out and replaced with what I called Army surplus bazookas but what Lydia lovingly called her “confetti makers.” With well over a thousand pounds of batteries in the trunk and back seat the thing handled like a bear, but then Lydia tended to drive straight toward her targets until she rolled over them, so that was all right.

Lydia opened her right fender magazine, using a rusty wrench and expletives from several different languages.

“I don’t want you to go,” I said, “tonight, to the duel.”

Liquid brown eyes flashed as delicate grease-stained hands loaded the rockets.

“We’ve been all over this a thousand times before, Jack,” she said. “These people are my friends. I’ve been in the club for years. The Commodores challenged us to a duel in the Ruins on neutral territory and we have to accept. It’s a point of honor.”

She put an edge on her voice. “But I don’t think you understand that. Instead of trying to talk me out of going, you should be coming with me. Don’t you have any pride?”

“When it comes to something like this? No. You and the rest of the Animals know the kind of resources the Commodores draw on. They got at least three retired professional duelists, half a dozen ex-Texas Rangers and just as many millionaire playboy types who have nothing better to do with daddy’s money than buy hot cars and hotter guns. Jesus Christ! They’ve got guys driving imported 9900s and you’re going to take them on with stuff like this? I drive a Mitsui and I still don’t see any honor in committing suicide!”

The access panel closed with a final “chunk!” End of maintenance, end of conversation, and quite possibly, end of relationship. I stared at the Monte while she changed from her coveralls to her battle armor. The Urban Animals were a motley bunch of auto nuts, gun nuts, and homicidal maniacs who were kept together by a mutual need for camaraderie and spare parts. I liked most of them. They threw good parties. They were going to get themselves exterminated.

Lydia returned, dressed for a fight. Damn! She looked good even with all her curves hidden behind those black ceramic plates. She slid into the driver’s seat, flipping switches with her left hand as she buckled her helmet over her sleek black hair with her right. Rolling down the window as she backed out, she yelled, “You’re a coward, Jack Freeburg!” and was gone.

The word was still hammering at my brain as I guided the 500ZX-terminator into the Checker’s

Pizza parking lot. I pounded the wheel with both fists and cursed Lydia for being such a fool and myself for being too smart to go with her. Coward? I had more than twice as many road kills as she did and she knew it. Still the word stuck in my gut and left me with a sick feeling no amount of rationalizing could shake. Okay, if that’s the way she wanted it, that’s the way she could have it. There were plenty of other ladies around.

Mama Dunbar glared at me through a cloud of steam from oven number one as I walked in off the street. She was wearing the “Death Drives a White Ford” T-shirt that Lydia and I had given her last Christmas at the staff party, which reminded me that there had been no other ladies for quite some time.

“Hey, Burger, what the hell do you think this is?” she bellowed, wiping tomato sauce from her puffy white hands. “A vacation resort? You’re forty minutes late. Get into the locker room and get your uniform on. Raoul’s been covering for you but I think he’s starting to get annoyed — and remember what Raoul did the last time that happened.”

I blew her a kiss — and muttered unrepeatables under my breath.

Raoul was pacing back and forth, nervously puffing on a cigarette, when I came grumbling into the locker room. He had shoulder pads in his jacket and his hair was pulled back neatly into a ponytail, so I decided he must have a date tonight with one of those vo-tech girls he was always chasing after. He said he was looking for a wife but I think he was just looking for a free mechanic. He gave me a short lecture on what a sorry, ungrateful putz I was while he cleaned out his locker. By the time he left I was starting to feel like everyone I knew had decided to dump on me at once.

I was still in that state of mind when the first call of the evening came in. The fellows over at the University wanted five large pepperoni’s, extra cheese. I hurriedly strapped my “Checker’s Pizza — We Deliver” sign to the roof of my car while Mama went to work at the ovens. This was one order that I was going to be sure was delivered within our half-hour guarantee. Those boys were in the middle of finals and were probably pretty testy; I didn’t need any trouble tonight of all nights.

Minutes later, with five large, extra cheese, pepperoni pizzas piled next to me in the front seat, I screeched out of the parking lot and into the deserted streets of the city. Things looked pretty calm tonight, but then, I was still inside the downtown fortifications, so that wasn’t too surprising. I’d have to go through the Ruins, south of Central Enclosure’s safety, to get to the University, but I didn’t expect any trouble from the scavengers who lived there. Compared to big cars, like the Kane Intercontinental, the 500ZX-terminator is cannon fodder, but it could still cream a crowd of pedestrians armed only with baseball bats.

The cops at the south gate looked us over a bit longer than usual before letting the 500ZX and me roll out of the no-duelling zone and into no man's land. More Uzi's than I like to think about were prominently displayed in the hands of frowning blue-coats and I thought I could see a couple of guys up on the wall with mortars. My guess was that someone had told the cops about the little party the Commodores were planning tonight, and they weren't taking any chances on it spreading into Central Enclosure.

As I maneuvered among the burned-out buildings and tattered tents that made up the ruins, I let my mind wander back to the thoughts of Lydia that had haunted me all evening. Somewhere among these debris-strewn streets, she and her friends were forming into battle lines. Was I a coward? Should I have gone with her? The answer, I decided, to both questions was an emphatic "NO!" The Urban Animals didn't stand a chance, whether I was there or not. I could just hope that Lydia had enough sense to know when to run away.

The sound of small arms fire in a building off to my left jolted me out of my reverie. "Damn it, Jack," I said to myself, "this is no time for daydreaming. Get your mind back on your work. It'll help you forget the trouble Lydia's in." And I wheeled around the next corner . . .

. . . into a wide, empty boulevard with the Animals three blocks behind me and the Commodores half a block in front of me. It looked like I was going to be part of this fight after all. I didn't have a radio but I knew Lydia would recognize a black X-terminator with Checker's Pizza markings as me, so as my windshield starred with the first .50 cal slugs, I stomped the brake pedal, gave the wheel a spin, and skidded around to present the enemy with my best side — the rear.

I watched in my mirror as I pulled away from the Commodores. I could only see five cars behind me: a white DT with the machine gun that had sprayed me, a station wagon rebuilt for ramming, two jet-black 9900s with turrets that spelled L-A-S-E-R, and something low and silver at the back of the pack that looked vaguely familiar and very dangerous. Something strange was going on here; the feature on the Commodores in *Texas Monthly* a few months ago had put their vehicle count near thirty. Where were the rest of them?

The Animals had turned out in full force. I spotted Lydia's Monte Carlo on the far left side of the formation. The club president, Jojo Munro, was leading the charge from the back of a jeep driven by Bunny, his wife. The old fool was hanging onto his tripod-mounted recoils rifle with one hand, waving on his troops with the cowboy hat in the other, and yelling at the top of his lungs, "Come and get what's coming to you, Commode-Doors!" At least a dozen other Animal vehicles were tooling up behind him.

As their ranks parted to allow me through, the

Commodores started shooting. A painfully bright green line of laser light flashed outside my left window, leaving red after-images dancing on my retinas. It charred a lovely hole in the hood of a sky-blue Thresher owned by some skinny kid named Bernard; he weaved a bit but didn't break formation. A few cars down the line, a Beetle with four Sparrowhawk heat-seeking missiles protruding from the hood wasn't so lucky. The DT hit it with a dozen or so incendiary rounds from its .50 cal, and the whole front end lit up like a fireworks display on Sam Houston's Birthday. The driver, a chunky young lady called Sledge, just had time to roll out the door before the rockets went off. Two launched and spun off to the right into a deserted storefront, blowing out ten feet of wall on the second story and showering the street with rubble. The other two must have exploded in their racks because I heard a "Whump!" and turned my head just in time to see the front end of the Beetle engulfed in a ball of flame and lifted four feet off the pavement. As the rest of the Animals sped past burning wreck, Sledge picked herself up, snapped the safety off her Scorpion, and ran like hell for cover.

Lydia and her friends returned the greeting with admirable effect. The 9900 that had zapped Bernard caught at least one of Lydia's anti-tank rockets and some recoilless fire from Jojo. The right front fender and wheel parted company with the rest of the automobile. Other Animals blasted away with various and sundry other types of weaponry, and while their results were not nearly as spectacular as those achieved by my little girl, several expensive-looking Commodore paint jobs were ruined. I turned around behind the Animal lines to watch the fight. It looked like maybe they had a chance after all. But why had the Commodores sent only five cars when they could just as easily have sent thirty? It didn't make sense.

Then I heard a sound that gave my stomach the flip-flops. From behind the ruined buildings came the dull "Whup-whup-whup-whup" that meant one thing: helicopter. And knowing the Commodores' reputation the way I do, I was willing to bet my best pair of boots that it wasn't the Laservision 4 Eye-in-the-sky out looking for some film-at-eleven. The chopper swung around the buildings at the end of the street. All black she was, with the golden Skull and Riding Crop of the Commodores stenciled on her nose, and she was bearing down on the battle like an avenging angel of death.

The Animals were so intent on pounding the ground forces that they didn't see her until she was right on top of them, and then it was too late. The gunner must have been wearing a cyberlink; nobody is that good on manual. Within seconds he sliced open at least four Animal cars like frogs in a high school biology class. Suddenly the street was full of twisted armor and fleeing drivers.

But, aside from the advantage of their air support, the Commodores weren't doing well. The wounded 9900 was struggling to escape from the

Monte Carlo's big guns. After ramming an X9, the station wagon couldn't separate its bumper from the smaller car's chassis, so it was dragging it around the street like a terrier worrying a rat. The X9 was already totalled, but the wagon driver would occasionally crush it against a wall or another car for dramatic effect.

The white DT that had taken out Sledge was backed against a building, taking pot-shots at the tires of Animal cars as they sped by. He blew the right rear on Bernard's Thresher and it fishtailed over a fire-hydrant before going into a roll that left it upside-down and smouldering on the sidewalk. While the driver of the DT paused to switch on his windshield wipers, Jojo popped up from behind his overturned jeep with a LAW on his shoulder. The section of wall immediately above the Commodore car exploded with a "Whoom!" and the vehicle disappeared beneath a big pile of rubble. Jojo blew a kiss to the still visible white hood, then quickly dove beneath his jeep as helicopter Vulcans clattered overhead.

Lydia cornered the crippled 9900 and fired two anti-tank rockets into its radiator grill. As the whole front end of the car fanned out like an exploding cigar, bits of power plant rained onto the street and the laser tube on the roof gave a final flicker and died. Blinking through his shattered windshield, the driver smiled at Lydia's artillery and slowly raised his hands. Score one for the good guys.

At that moment, the Monte Carlo caught the attention of the Commodore flyboys. Two air-to-ground missiles slipped smoothly from their racks beneath the chopper and, gracefully trailing

streamers of white smoke, homed in on the automobile. They detonated on the trunk, vaporizing a good quarter of the rear deck and badly cracking the rest. Lydia tried to bring the Monte around to get the bazookas pointed at the bird, but the old clunker was just too slow, and before she even had a chance to shoot back, they opened up with the Vulcans and shredded the back end of her car. Cracked batteries and incendiary ammo don't mix, and by the time she was halfway out the door, the Monte's rear was an inferno. As she ran, the fire spread and seconds later the remaining rockets went off in their clips: "Whoom!" Lydia's car was in pieces all over the street.

I had been sitting back, watching the fight from a safe distance, but seeing my little girl out of her car, running around in the street where *anybody* could shoot her by accident, made me very nervous. I decided that it was time for Jack Freeburg to get involved. I pointed the X-terminator toward the fracas and gunned the motor. We shot forward. I was a bit lighter in the arms and armor department than most of the vehicles I had seen tonight, but pizza delivery usually requires more in the way of speed than firepower, so I was betting that if I could get Lydia in the car, we could outrun whatever might decide to follow us.

Weaving in and out of smouldering wreckage, I noticed that the brawl was coming to an end. Only four Urban Animal cars were still on their wheels and they were skirmishing with the other 9900 and the chopper off to my left. Someone had mercifully shot the tires off the station wagon, and now it lay

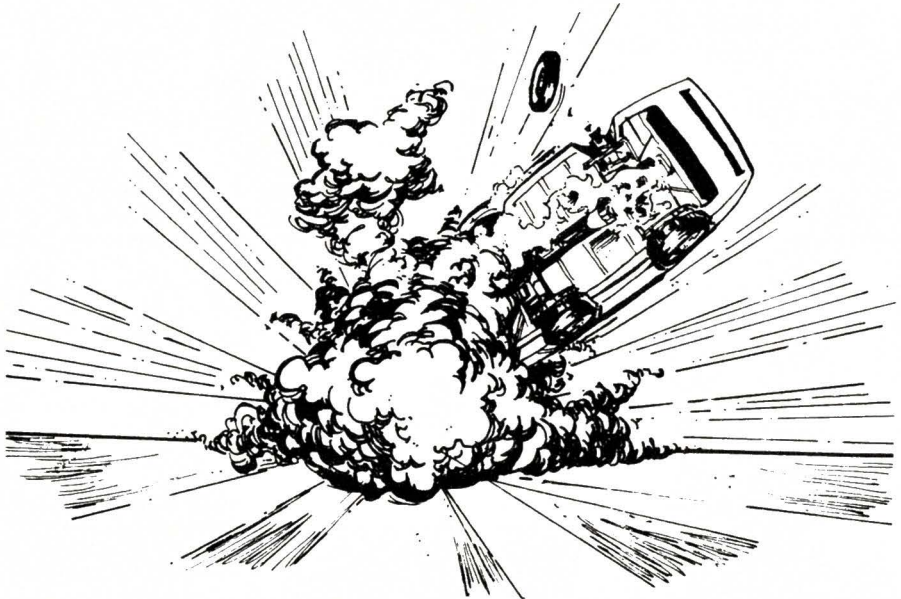

half on, half off the sidewalk to my right, the X9 still clutched in its jaws. Drifting smoke and a fine mist from the broken hydrant filled the air. I could see Lydia hiding behind Bernard's deserted Thresher with her pistol drawn. Beyond her crouched that low silver car whose lines I'd been unable to place. It had held back during the fight, but now it unmistakably had her pinned down.

I tried to keep the Thresher between me and the silver car as I steered toward Lydia, but it could see me coming and it got a few shots off at me just the same. Slugs from the single recoilless muzzle that protruded from its front end spanged off my armored hood. They chewed up the finish pretty bad but it looked like I'd be okay if I could get away before he nickel-and-dimed me to death.

I skidded to a stop less than ten feet behind Lydia. Apparently this came as a surprise to her, because when she heard the screech of my tires she spun around and emptied a clip into my right door panel. When the smoke cleared, her look of terror faded to one of embarrassed recognition and she ran toward the car. As the door slammed shut behind her, I gave the 500ZX the juice and we roared off in the direction I came from.

As she snapped another clip into her Tex-Mex War surplus .45, I smiled and said, "I told you to carry something with a little more 'umph!' than that antique your father left you."

"Jack?"

"Yes?"

"Shut up and drive."

"Aren't you even going to thank me for saving your life, dear?"

"Thanks. Now shut up and drive."

I can't say I blamed the lady for being testy. Having your car shot out from under you does that to you.

As I floored it, I glanced in the rear-view mirror. We were pulling away from the Thresher at a pretty good clip while the silver car was just coming into view from behind it. I could see the helicopter finishing off the remains of the Animal pack but it didn't seem to be paying any attention to us. I felt safe. Then I looked back at the silver car and the feeling faded. In the split second I'd looked away, it had cut the distance between us in half. Wait a minute, I thought, they can't *make* cars with that kind of acceleration . . .

Then something inside my head went "click!" It was two years ago, in the August issue of *Car & Driver & Guns & Ammo*, that I'd read a feature on gasoline antiques. I remembered particularly vividly a photo of the fastest production car ever built; they called it a Vector W-2. Two years ago I'd been amused — "vector" meant "directed speed." Now I was horrified — two tons of directed speed was burning its way up my tail. Literally burning, I might add; electrics are safer and cheaper than internal combustion, but when it comes to speed, the old IC can't be beat.

I braked down to 40 and squealed around the corner, leaving most of the battle behind. Unfortunately, a critical part of it was still on my tail and closing quickly. The Vector's driver started in with his recoilless rifle again and I felt the 500zx shudder each time a shot slammed into its rear armor. I tried weaving to throw off his aim, but the old gas guzzler handled like a jet fighter and he stayed right behind me, hammering away.

As the speedometer passed sixty, I turned to Lydia and tried to smile. "Look at it this way, honey," I said, "things can't possibly get any worse."

At that moment the black chopper appeared above a deserted bank building to our left. Apparently it had finished off the remaining Urban Animal cars. Never ones to be satisfied with a mere victory, the Commodores were looking for something more along the lines of an extermination. Lydia and I and the 500ZX-terminator were the only obstacles between them and perfection. We were going to be removed.

The bird was maneuvering a bit erratically; it looked like the tail rotor had taken a hit and was no longer working quite right. Thank the Lord for small favors. The Vulcans still rattled away above us, however, and incendiary bullets rained down all around us. (Zippo loads are expensive, too, and I was beginning to wonder how they could afford to be shooting it off right and left.) The back window shattered in a spray of plastic slivers and two or three bullets from the Vector pounded the windshield from the inside. I slid down in my seat and drove looking through the steering wheel while Lydia squeezed off round after round from her .45 through our missing rear window. A rubber band gun would have been about as effective, but I appreciated the gesture.

Suddenly all the shooting stopped, except for Lydia, who kept popping away with her pistol until the clip was empty. I glanced behind us and saw that the Vector was inching toward us, closing the distance between our bumpers to four car lengths, three car lengths, two and a half, two. After a few seconds of confusion I realized what the slime-ball was planning to do: He was trying to get close enough to target Lydia and me through the shattered window without hitting the rest of the car. Lydia realized the same thing. He was a half car length behind us, the muzzle of his gun looking like a black gulf ready to swallow us up, when she said:

"Damn him! Everyone knows you're supposed to shoot for the car, not the driver. It's just not sporting."

"Neither is this, dear," I replied, and dropped a load of mines.

I don't think the poor dumb putz knew what hit him. He should have known better than to tailgate a Checker's Pizza car anyway. When you're on a run you don't have time to stop and tango with any crazy that takes a dislike to you, so you turn tail and discourage them from following you. If he'd just

hung back he would have had plenty of time to avoid the things and he could have had Lydia and me for lunch. It never pays to get cocky.

The first mine went off under his front tires. I saw the flash in my mirror and the concussion rattled us pretty good. One of his wheels bouncing off to the right, he went into a skid and set off another firecracker. The second blast heaved the right side of the Vector into the air at precisely the moment its driver needed all the traction he could get. At seventy miles per hour the thing went into a roll, bouncing off the ground, spinning several times in mid-air, then bouncing off the ground again, and every time it hit, it spewed twisted metal onto the street. I sped up in anticipation of the inevitable. Seconds later the fireball mushroomed behind us. There are certain hazards that go with owning an antique.

Although a serious threat to our health lay blazing in the street behind us, our celebration was short-lived. Our friend in the sky opened up on us again with his Vulcans, this time with a vengeance. Incendiaries smacked into my rear deck, igniting the plastic armor wherever they hit. The black chopper was low on my tail. I started wishing I'd bought the optional surface-to-air missile rack instead of the sport trim. Mines don't do a whole lot of good if their intended victim is ten feet off the ground.

I had just about given up hope when we zoomed past the main gate to the University. A ray of sunlight broke through the clouds. Like Central Enclosure, the University was a no-duelling zone. If we could make it into there, the Commodores wouldn't dare follow us, and, I realized joyfully, the boys at the residential entrance were waiting to let us and the pizzas in.

As I circled the University looking for our way in, Lydia dug a fire-extinguisher out from under her seat and was trying to use it on the rear deck. The chopper kept her pinned down most of the time, but every once in a while it would have to dodge a tree or building, and then when the shooting stopped, she'd stick her head out the shattered rear window and spray foam onto the flames. As soon as she'd put them out, though, the gunner would get us in his sights again and she'd have to duck back inside as a new batch of incendiary slugs rained around us.

I saw the gate ahead of us and started honking the horn. Figures on the wall looked up from their books and grabbed their sub-machine guns. They were ready to open fire when I saw them recognize the bullet-ridden Checker's Pizza sign still clinging to my roof. The gate started moving and I aimed for the widening gap in its center; we were approaching faster than they could open it and I wanted as much of the car as possible to make it inside.

We threaded the needle with no room to spare — the gate's edge neatly sliced off my left side mirror and moulding. There was a sickening "Pow" as the unretracted gate spikes blew all four tires, and we fishtailed violently to the left. I struggled to keep control and sparks flew as the bare wheel-rims

skidded across concrete. The back end slewed to the right, then back to the left, we spun completely around twice, jumped a curb and finally came to rest against a stately oak.

I turned on the wipers to clear the leaves off the windshield, and through the cracked plastic saw the helicopter come over the wall after us. This was not a smart move, particularly during finals week when the Weapons System Engineering majors needed a way to blow off steam. I counted muzzle flashes from at least a dozen different windows before a crew on the dorm roof fired what looked like a senior design project cannon at the hovering chopper. They blew the tail right off the thing and with the stabilizing rotor gone the whole craft went into a nasty spin. There was a very satisfying "Crunch!" when it hit the parking lot. Before it exploded the pilot and the gunner piled out and ran like crazy for the closing gate. I hoped they had a nice walk home.

I turned around to ask Lydia if she was all right, but before I could open my mouth, she grabbed my head with both hands and gave me a long, slow kiss. When we came up for air, she said:

"I'm proud of you, Jack. I really am."

I blinked.

"Why?"

"Because of what you did. Because you did the honorable thing. I'm sorry I called you a coward, but I never thought you'd come looking for us like that to help us. Can you ever forgive me for doubting you, darling?"

I started to tell her that I'd only wound up in her fight by accident, but stopped myself in time. Jack, I said to myself, here's your chance to get back on her good side.

"There's nothing to forgive, dear. After you left I thought about what you said and decided you were right, so I headed out in the ruins to find you and prove to you that I knew what was right, too."

I was ready to kiss her again when I heard a rap on the window behind me. It was some pimply-faced kid pounding on the plastic with his .44 auto-Mag. I rolled down the window.

"Hey, man," he said, "where's our pizzas? We ordered them forty-five minutes ago and you're supposed to deliver in half an hour."

I cringed and Lydia's mouth dropped open.

"Pizzas?" she said. "Jack Freeburg, do you mean to tell me you were on a delivery run while I was out fighting for my life?"

Her voice was getting shrill.

"Baby, baby, calm down," I said, "this guy doesn't know what he's talking about. There must be another car on the way with their delivery right now. I don't know anything about pizzas."

"If you don't know anything about pizzas, then what's that the lady's sitting on?"

I really wanted to slug that kid. Lydia raised up in her seat and stared at the greasy boxes underneath her. She dragged one out, opened the lid and held it in front of my face.



Keith Miller  
1987

Next thing I knew, I had pepperoni pizza up my nose and spilling down the front of my shirt. Blinking tomato paste out of my eyes, I heard the car door slam and the click-click-click of Lydia's duelling boots walking across the parking lot. I thought of yelling to her to come back and we'd talk about it, but I realized it wouldn't do any good. In her eyes I had betrayed her and that was that.

The kid bent over and tapped me on the shoulder.

"Hey, are you going to give us the pizzas or not?"

I turned and glowered at him.

"Sure. Checker's Pizza . . ."

I decked him with a left jab through the window.

" . . . We Deliver."

### GAMING NOTES

Pizza delivery isn't exactly the way to fame and fortune, but it's a good way to pay the bills between AADA events . . . Since most delivery runs are within the walls of a fortress town, dangerous action is actually fairly rare. But there are always exceptions, and these are what makes a pizza delivery driver's life interesting.

Deliveries to or through hazardous territory ups the price of a pizza considerably — a large pizza with everything, delivered under hazardous conditions, could cost as much as \$75, not counting tip. But potentially car-wrecking battles are few and far

between — if delivery drivers were taken out every other day, the pizza delivery company would go out of business. No, the more common hazards are pedestrian bandits and motorcycle crazies who go for one lucky shot and then dive for cover before they're vaporized. They're not very dangerous, really — just annoying.

Jack Freeburg's Mitsui 500ZX-terminator is a pretty good delivery vehicle — quick, maneuverable, and heavy on defensive weaponry. Here's how to build it:

Mitsui 500ZX-terminator: Mid-size, hvy. chassis, hvy. suspension, super power plant, driver, passenger, 4 solid tires, MG with HD ammo front, MD back, 6 smoke dischargers. Armor: F35, R30, L30, B45, T15, U20. Portable fire extinguisher in cargo area. Remaining cargo capacity: ½ space, 30 lbs. at 10 accel., 110 lbs. at 5 accel. Acc. 10, HC 3, 5, 170 lbs., \$13,050.

As far as the gasoline powered Vector W-2 . . . sorry, Freeburg just blew up the last one in existence. Seriously, we'll be dealing with gasoline-powered vehicles in an upcoming supplement. It would take up too much room to deal with them here. And you already know the basics from the story — great acceleration and speed, good handling, and an alarming tendency to blow up . . .

Incendiary ammo and portable fire extinguishers are fully described in this issue's Uncle Albert advertisement, pages 4-5.



# Excerpts from the NORTH AMERICAN ROAD ATLAS AND SURVIVAL GUIDE, 3rd Edition

by Greg Porter

Cumberland is located in the “pan-handle” of Maryland, 90 miles southeast of Pittsburgh on National 40. With a population of nearly 30,000, this center of industry was rescued from slow death by its citizens’ quick adaptation to the radical changes that occurred at the turn of the century.

## HISTORY

By the time the 30-year decline of American heavy industry hit bottom, Cumberland was on the brink of collapse, all of its major industries in a slump. Unemployment hit 70%, and there was nothing to attract fresh blood or new industry. When open combat on the roads broke out, and cycle gangs started terrorizing populated areas, it was the boost that Cumberland needed. The Kelly Springfield Tire Company, Victory Plastics Corporation, and the Allegheny Ballistics Laboratory (a former defense contractor specializing in rocket engines for anti-tank and anti-aircraft missiles) found themselves swamped with more orders than they could handle. Cumberland’s new “Big Three” made the town a center for solid tires, crude but lightweight ceramic/plastic armor, and unguided rockets of all types. Nearby Frostburg has a small technical college with majors offered mainly in fields which support local industry.

## POINTS OF INTEREST

1) “*Petrol Pete’s*” *Real Oil Well* — 10 miles northeast of town on Route 220,

this is a producing oil well with an output of nearly 100 barrels a day. Adjacent is a museum and restaurant. Pistols may be worn if secured in holsters, but security is otherwise tight.

2) *Chessie Roundhouse* — Located on the south side of town on Route 28. Several mint-condition diesel-electric locomotives are on display here, as well as a few armored locomotives formerly used on steel runs to Pittsburgh. The diesel repair bays have been converted to general purpose vehicle repair, and will accommodate anything up to and including a big rig. Repair rates are reasonable.

3) *Raider Vic’s* — Three miles south on Hershberger Road. Rowdiest place in town. Also best food and moonshine in the area. Open all night, but usually closed from 9 a.m. to 3 p.m. for repairs. Avoid the midnight and 3 a.m. brawls if alone.

4) *Cumberland Raceway and Proving Grounds* — Three miles southwest of town on McMullen Highway. Formerly a half-mile oval, it has been leveled off into a packed dirt autoduelling arena. Non-lethal paint bomb battles are held here on weekdays and holidays. Firing into the crowds is punishable by a \$5,000 fine and/or confiscation of vehicle. On weekdays, the arena is open for vehicle and weapons testing on an AADA-certified practice range. The Cumberland Valley Rocketry Club has the area reserved for meetings and practice every other Tuesday.

5) *Scrambled Ed’s* — Six miles east of town on National 40. Major arms dealer in the area, Ed will do armor refits, rockets, all types of guns and custom work. A small track and firing range is on the premises. AADA specials include free installation with any \$1,000 or more purchase, and a 10% discount on any

weapon bought in quantities of 10 or more. Ed's is also the best source of information on any illegal activity or serious duelling in the area.

6) *Frostburg* — Ten miles west on National 40. Situated on the slopes of Savage Mountain, this community of about 8,000 is composed mainly of college students and commuters to industry in Cumberland. Tractor-trailers are prohibited on the highway through town to prevent repeats of the destruction caused when a runaway lumber truck missed a curve and took out a small apartment complex in 2027. Also, no vehicles are allowed on the campus of the State College. This law is enforced by remote-controlled minefields and rocket launchers at all entrances.

7) *Flintstone* — A small walled community of about 500, it parallels National 40 about 20 miles east of Cumberland. Moonshine is the major export. Almost every inhabitant is well-armed at all times, as the area is only marginally within the Cumberland sphere of influence. Main feature of interest to autoduellists is The Stretch, a 1.4-mile flat, straight piece of highway used as a local drag strip.

## FACILITIES

Cumberland has several lightly-fortified service and recharge stations on National 40 and other minor highways. All major repairs are done downtown at the old trainyard, which can service all types of vehicles. Most tires, armor, and rocket-related equipment are available at a 15% discount at stores all over town. Locals can usually get a 25% discount. Electronics and computer equipment are scarce, and are 30% over list price when available.

An interesting sidenote: Petroleum products are available in this area. There are several small gas and oil fields which were unprofitable to exploit until they became the only way to make synthetic

rubber and rocket engine binders. Prices are extremely high to non-locals, making it unprofitable to ship out of this tiny reserve. The easy availability of gas to locals (albeit in very limited quantities), and the large number of stills in the area combine to make for a surprisingly high number of gasoline- and gasohol-powered vehicles, especially in the rural areas where there is little or no electric service.

The town defends each major approach into town with multiple linked rocket launchers, with additional rolling rocket platforms for mobile defense. This and the armament of the local populace has been enough to turn away every major threat to the town in recent memory.

## ORGANIZATIONS

The Eastern Driving Safety Enforcement League has nearly universal support in this area, but this non-lethal approach doesn't apply to disputes with outsiders. Most local arguments are settled by rocket-powered paint bombs, races, and games of "chicken" on the twisting mountain roads in the area. The EDSEL office is located in the Country Club Mall, with branch offices in Frostburg and Flintstone.

The Cumberland Valley Rocketry Club (CVRC), locally thought of as a few wheels short of rolling, meets at the Cumberland Raceway every other Tuesday. They experiment with home-made rockets and explosives of every type. "Smokin' Lefty" Howard, retired club president, holds the North American record for longest survived non-internal-combustion-powered cycle jump, managing to fly 347 feet before impact. Treat any offers of free equipment for testing a new device with extreme caution.

The AADA has a small office in town, but its major function is as an arbiter in serious duels and coordination of town defense forces. The office is at the corner of Mechanic and S. Main.

# AUTODUELLING IN CUMBERLAND

Cumberland, all in all, is a rather tame town, but a good place to have some clean fun and pick up new equipment. Avoid small, uncharted roads, as some rural inhabitants are not fond of strangers and will shoot before asking questions.

Inhabitants of the rural areas are almost always armed, and most vehicles, if not full-fledged duelling machines, at least have a few LAWs behind the seat. Locals treat out-of-towners reasonably and with the same respect that they are given. Duels are by permit only within town limits, and duellists must post bonds to cover possible damages. All town ordinances are enforced by local police, who are polite but heavily armed.

Cumberland is in the heart of the Appalachians, and most roads are on

slopes steep enough to affect performance. Sharp turns are common. National 40 is two lanes in most places with wide, paved shoulders. Most other roads are also two-lane, but with little or no shoulders, more frequent and steeper turns, and steep dropoffs on the downhill side.

For those interested in commerce, export items are explosives, rockets, moonshine, armor, and all types of tires. Items in local demand include raw metals, electronic equipment, and salvageable internal combustion engines, all of which bring premium prices. The rural areas around Cumberland are not patrolled regularly, and a few well-organized gangs prey on convoys that wander off the main roads and/or look poorly guarded. These bandits tend not to work too close to town, however — the main highways within 20 miles of Cumberland are generally safe.

## Cumberland, Maryland

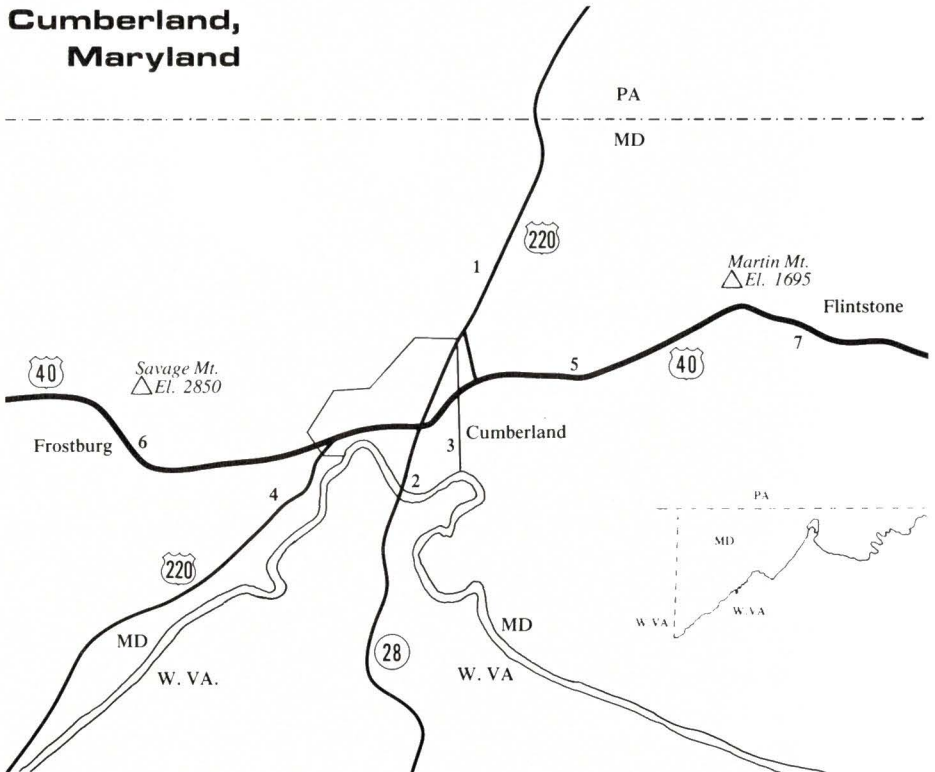

# FIRST BLUD

by **Scott Haring**

*“All right, all right, settle down now. We’ll hit the track in just a little while, but we’ve got to get a little business done with first.” The wrench banged on the podium again. “First off, I want to thank the management here at the Brett for letting us come out here and practice at a substantial discount to their regular rates. They’re not making any money off of us, folks, so it’s important that you give them your business at every opportunity. Also, for those of you who are new to this AADA chapter, I want to emphasize that this is non-lethal practice duelling we’ll be having out here today. That means targeting lasers and paint-pellet ammo only. All other weapons must be unloaded or disconnected. We will be checking your machine before you’re allowed out on the track. We’re all friends here, but tempers can get short at high speeds, and we don’t want any accidents out there. Now, the first official item on our agenda . . . ”*

*“Those of you who used to be associated with those wimps know the procedure. They’re going to have unloaded weapons, except for paint pellets — can you believe that? — paint pellets. We’ll see how far their paint stacks up against live ammo, eh? This’ll be the end of their flowery speeches and their goody-goody rules. Today, the AADA learns that autoduelling is played for keeps — and BLUD plans to come out on top . . . ”*

“First BLUD” is a *Car Wars* scenario for a referee and just about any number of players. BLUD is “Big League Unlimited Duelling,” a “rogue” autoduelling group. The referee will take the part of the BLUD members intent on breaking up the AADA practice session. The players will be members of the Kansas City AADA chapter, holding their monthly meeting and practice at the George Brett Memorial Autoduel Arena, the latest addition to the Harry S Truman Sports Complex on the east edge of Kansas City, just off of I-70.

Getting your players to go along with this scenario may take some creative storytelling on the part of the referee. Normally, inviting the group of players over for a scenario that involves “friendly practice” will only raise their suspicions. One tactic that may work would be to *tell* your

players that another scenario is planned, and then ask to “test out” the practice duelling rules . . . “just to see how they work.” *Then* spring the BLUD attack on them, and see what happens! If your players are good roleplayers and can separate what *they* know from what their *characters* know, then such duplicity will be unnecessary.

A layout of the George Brett Memorial Autoduel Arena can be found on page 31. In addition, on page 23 there is a general layout of the grandstands, parking lots and support buildings. A more specific map showing the management offices, meeting areas and VIP areas can be found on pages 24–25. As the scenario begins, the players’ vehicles will be parked more or less in a row by the edge of the track. Normally, there will be a barricade pro-

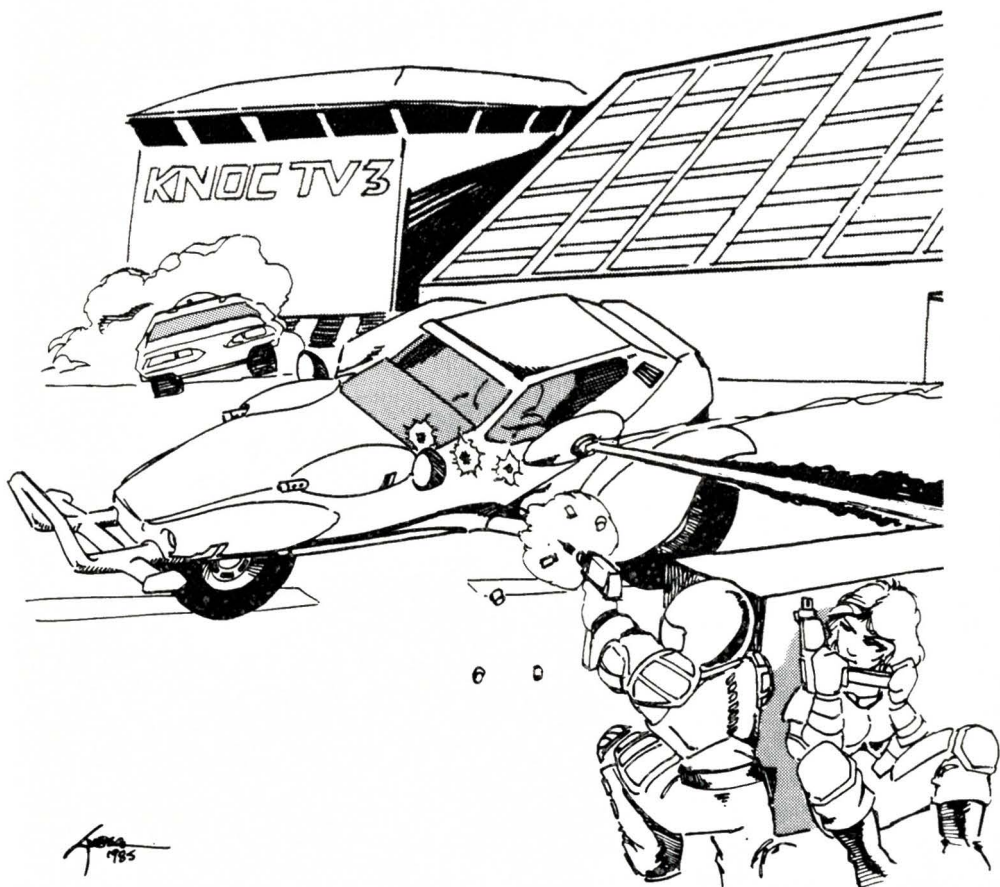

tecting the folks in the VIP area from the duelling action, but it's been taken down for this "friendly" event. Let your players use their regular duelling vehicles — although they'll have to be modified for non-lethal combat (see the section on "practice duelling" at the end of this scenario).

There should be 8 or 10 vehicles ready to participate in the practice session. If there aren't enough player vehicles, then add some stock vehicles out of *The AADA Vehicle Guide* (modified for practice, of course). There should also be about 30 pedestrians, including the players. Most of them will be in the front two or three rows of seats in front of the stage; a few others will be milling around the cars, or walking around the area. Another 10 to 12 stock vehicles will be in the VIP parking lot. These are the personal vehicles of those AADA members who came for the meeting and to watch the practice, but not to participate. As a result, these vehicles are fully combat-ready — but they'll be a little hard to get to once the attack begins . . .

Pedestrians may have body armor (certainly those planning to join in the practice session will), and no one will be carrying a hand weapon more powerful than a heavy pistol — after all, everybody's among friends. If the referee desires, a few pedestrians may have a machine pistol or a grenade or two.

This is not to say that the Brett is devoid of security. The fence surrounding the VIP area has 5 DP if rammed, but has mines along its base to discourage such activity. It also has barbed wire across the top — climbing it takes 3 seconds, 5 if the climber is in body armor, and may do damage to the climber (roll one die: on a 1-3, no damage, on a 4-5, one point; on a 6, two points). In addition, there are four track security guards in the security office in the corner of the building; they are Runner +1, Handgunner +1, and all have body armor, an SMG, a heavy pistol, and 3 grenades. There are also two more

guards in body armor with 3 LAWs each at the car entrance from the VIP parking lot. The gates are wide open, as no one is expecting trouble. Then the fun begins.

## THE ATTACK

The BLUD forces aren't particularly numerous — but they are well-armed, and they do have the element of surprise. The BLUD lineup:

Vehicle One — Stock Hotshot. Driver is Driver, Gunner +1, with fire-proof suit and body armor, a pistol, shotgun, and 3 grenades.

Vehicle Two — Stock Decade Station Wagon: Station wagon, x-hvy. chassis, large power plant, hvy. suspension, 4 PR radials, driver, 3 passengers, RR in turret, SS back, hi-res computer, sleeping area, fire ext. Cargo capacity: 125 lbs., 4 spaces. Armor: F30, B35, R20, L20, T20, U15, four 10-point wheelguards. Acc. 5, HC 3, 5,875 lbs., \$18,000. Driver is Driver, Gunner, Handgunner, and has hvy. pistol and 3 grenades. Passenger I is Handgunner +1, Runner, and has improved body armor, a fire-proof suit and a portable flamethrower. Passenger II is Handgunner, and has body armor, an SMG, a LAW, and 2 grenades. Passenger III is Handgunner, and has body armor, a machine pistol, 3 VLAWs, and 2 grenades.

Vehicle Three — Stock Lumberjack "Lucky Pierre": X-hvy. trike, super trike power plant, OR suspension, 3 OR solid tires, driver, gunner, RR in turret, MG right, MG left, link for MGs, brush-cutter, fire extinguisher, 2 targeting computers. Armor: F20, R15, L15, B20, T15, U10. Acc. 5, HC 2, 3,500 lbs., \$17,320. Driver is Cyclist, Gunner, Handgunner, and has body armor, an SMG, and 4 grenades. Gunner is Gunner +1, Handgunner and has improved body armor and 3 LAWs.

The Lumberjack and Hotshot will lead the charge, while the Decade will slow to

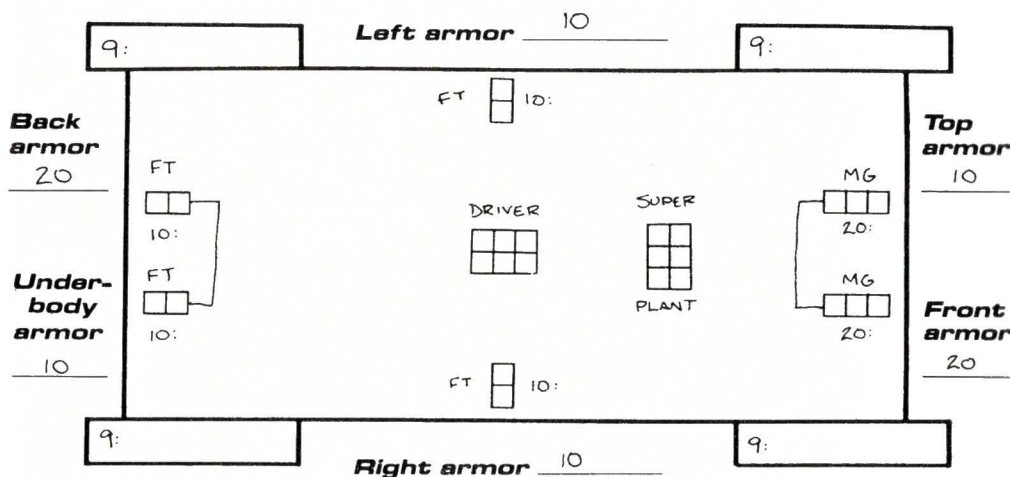

**Vehicle** HOTSHOT **Driver** \_\_\_\_\_  
**Size** LUXURY **Weight** 6,600 **Chassis** X-HVY **Suspension** HVY  
**Acceleration** 5 **Handling Class** 3 **Cost** 14,600  
**Extras** FIRE EXTINGUISHER

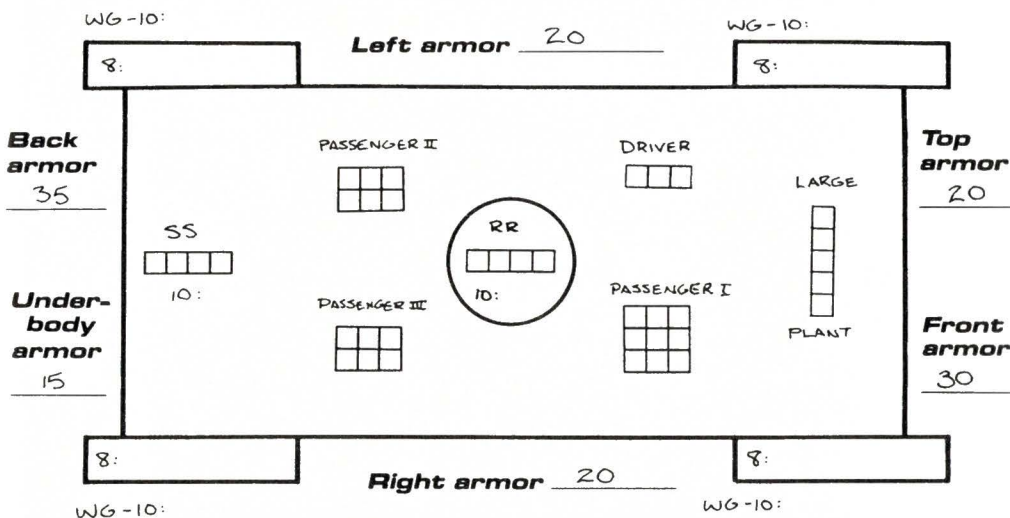

**Vehicle** DECADE **Driver** \_\_\_\_\_  
**Size** Sta. Wgn. **Weight** 5,875 **Chassis** X-HVY **Suspension** HVY  
**Acceleration** 5 **Handling Class** 3 **Cost** 18,000  
**Extras** Hi-RES COMPUTER, FIRE EXTINGUISHER, SLEEPING AREA

Back armor 20

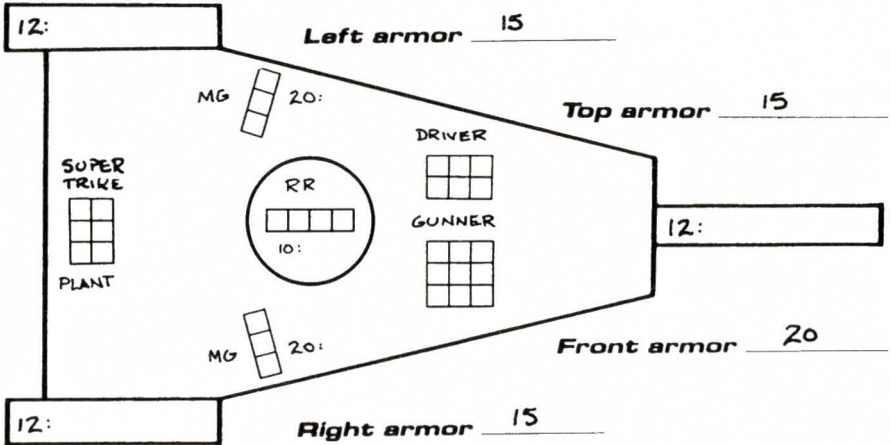

Underbody armor 10

Tricycle LUMBERJACK "LUCKY PIERRE" Driver \_\_\_\_\_  
 Size X-HVY TRIKE Weight 3,500 Chassis \_\_\_\_\_ Suspension OR  
 Acceleration 5 Handling Class 2 Cost 17,320  
 Extras BRUSHCUTTER, FIRE EXTINGUISHER, 2 TARGETING COMPUTERS

10 mph and let out the three passengers. The vehicles will crash the gate, while the three pedestrians will start on the cars in the VIP lot (the portable flamethrower should come in very handy for property destruction). The BLUD goal is simple: Destroy as much AADA property as possible and kill lots of AADA-ers. The AADA players will have the superiority in numbers, but not in firepower; their goal should be survival.

If BLUD times everything perfectly, they'll hit the gate while all the AADA members are down at the stage holding their meeting — a long way from their cars. But what if they're late? A very interesting variant would be to hold off the BLUD attack until some of the AADA vehicles are on the track, with practice going on at full blast. It would certainly give the AADA more of a chance, because even though the cars on the track won't be armed, at least they'll be moving. Referees considering this variant might want to beef up the BLUD forces a little, perhaps by adding a fourth vehicle.

## PRACTICE DUELLING

Non-lethal practice sessions make a nice change of pace for an ongoing campaign.

The main difference in "practice duelling" is in weapon modification. All weapon ammunition is replaced with paint pellet ammo designed for each particular weapon. Paint pellet ammo costs \$1 per shot and has the same weight per shot as the ammo it is replacing. Almost every weapon known in *Car Wars* has paint pellet ammo available; only the tank gun, gauss gun, flamethrower, and autocannon are exceptions. Those four weapons must be completely unloaded before a vehicle equipped with them will be allowed to practice; in fact, no live ammo is allowed where the driver can get to it. Weapons with paint pellet ammo must be completely empty of live ammo as well.

Lasers are a special case. Targeting lasers are allowed, because they do no damage. More powerful lasers are usually just disconnected, but a device is available



# Parking

Howser St



■ TV Bunkers

Saberhagen Dr

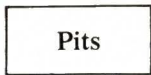
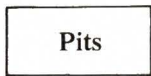
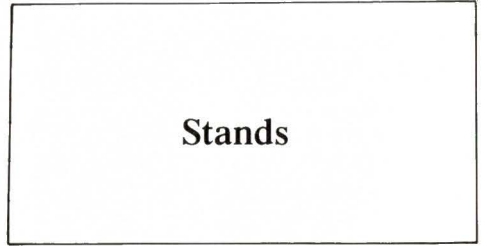
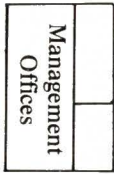

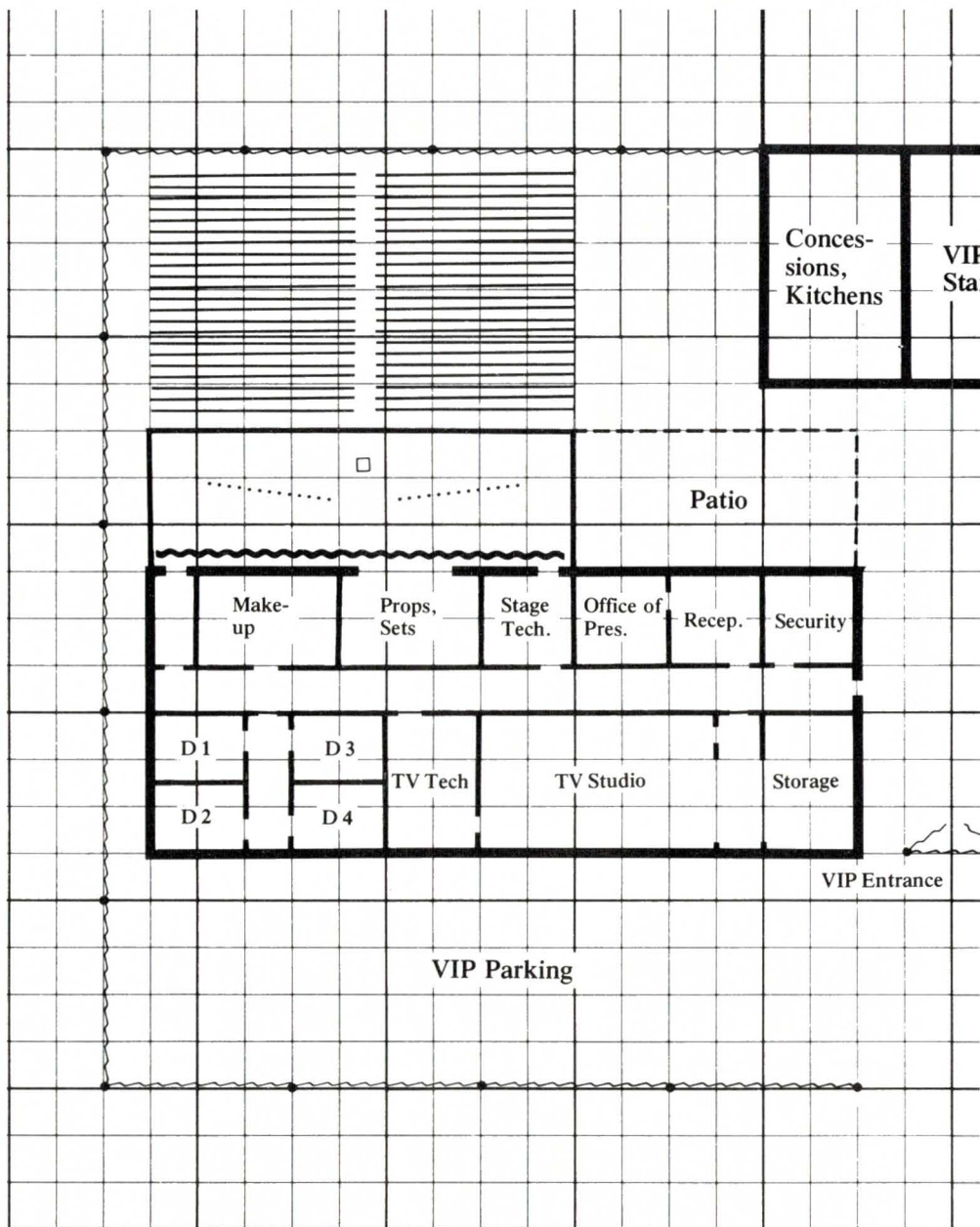

(\$200, no weight or space) that will reduce the output of a laser to that of a targeting laser. This device is attached to the laser itself, and putting one on or taking one off is considered a Trivial job for a mechanic — that is, anybody can do it. The device can only be installed or removed from the

outside of the vehicle. Rockets can use a laser guidance link in practice sessions, but paint rockets must be used. They cost half as much as the regular rocket they replace, and have the same weight. For example, a heavy paint rocket costs \$100 and weighs \$100 lbs.

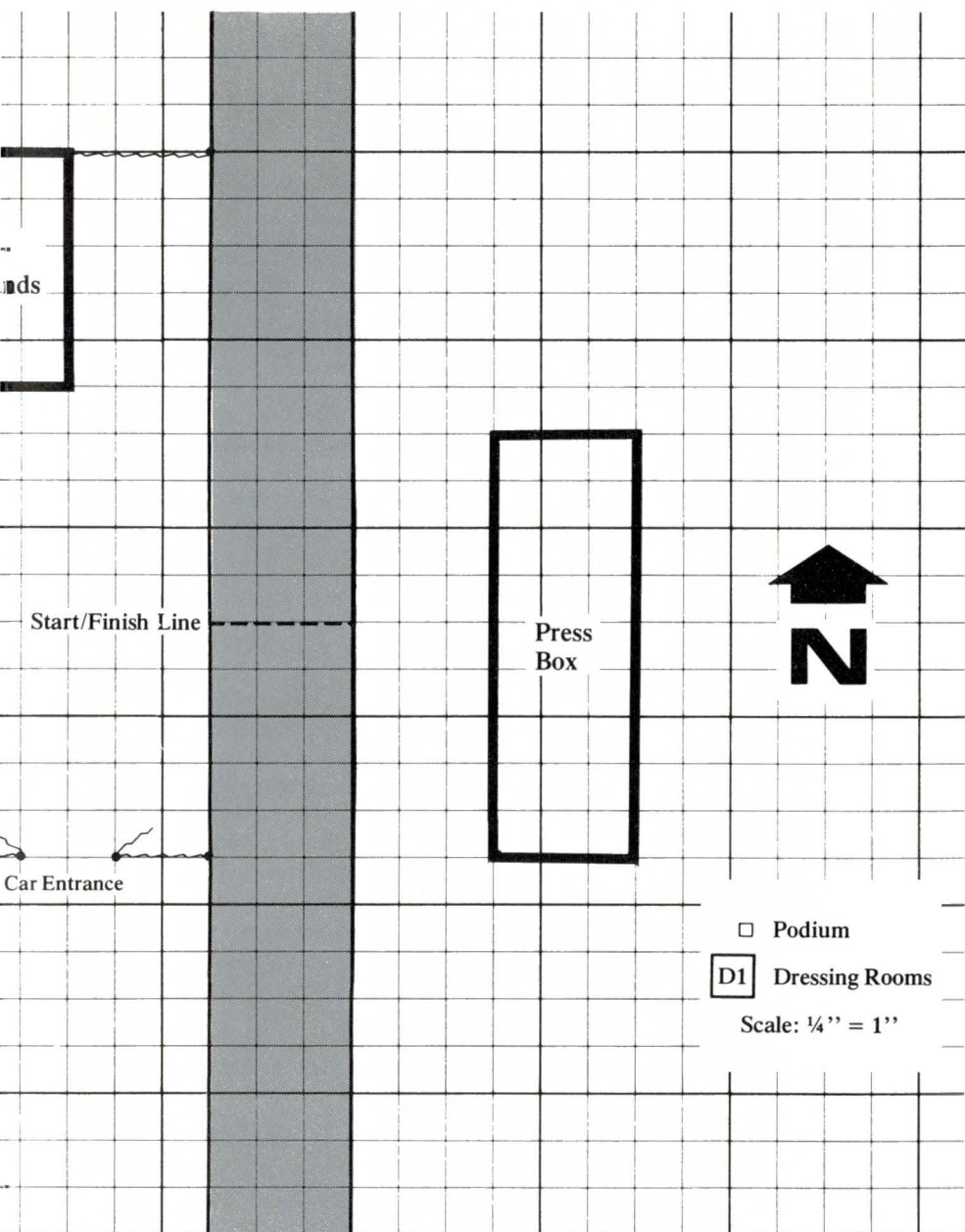

The use of any type of dropped weapon is prohibited, though paint and smoke weapons are allowed. There is no practical way to disarm or remove ramplates, but ramming — with or without ramplates — is strictly prohibited. Obviously, bumper triggers are also not allowed.

Each participant in a non-lethal duel is assigned a different color of paint pellet, so it can be easily established who hit whom. Laser hits are tallied by computer.

Non-lethal duels are good practice, but not as good as “live” action. Driver and Gunner skill is earned in practice

duels as if it were live action, but only at 1/10 the rate. Additional awards for bravery and exceptional luck and the like cannot be earned in practice duels — it's just practice, after all, and the heat isn't really on.

Non-lethal duels can also be used as a basis for friendly competition. Each hit is worth a point to the vehicle that fired the shot, and minus one point to the vehicle hit. Tire and turret shots could be worth more points, depending on how the participants wanted to set up the ground rules. While this type of duelling will never catch on nation-wide (it's not violent enough), it's a great way for small groups to compete among themselves without losing too many members to combat fatalities.

## FUN AT THE BRETT

Of course, the George Brett Memorial Autoduel Arena is more than just a practice ground for the Kansas City ADA. A full slate of events are run at the Brett, including Amateur Night and local celebrity events. As you can see in the diagram on page 23, the Brett has ample parking and a large, well-protected grandstand that provides a fine view of the action. The VIP area also has a number of other facilities beyond the patio and special grandstands.

The stage is used for award presentations, news conferences, and meetings. Directly behind it is a storage room for props and sets, a make-up room, and a

technical room with full light, audio, and set controls for the stage. Next to them is the office of the president of the track, a reception area outside his office, and the security office. The security guards stay in that office when they're not on patrol. A number of hand weapons are kept in the security office — 3 LAWs, 3 SMGs, 12 grenades, 6 tear gas grenades, 2 grenade launchers, 3 shotguns, and 2 rifles.

On the other side of the long hallway is a TV studio (the largest room) and various support areas. The track management uses the studio for interview shows and putting together highlight packages for distribution to the networks. Sets are stored in the room in the southeast corner, and west of the studio is the control room. Beyond that are four dressing rooms.

The patio is a general meeting place and watering hole for the duellists, media, local politicians and celebrities, and other important persons to meet and hobnob and do whatever it is that celebrities do. They serve fairly good food, too. Behind the VIP stands is a concession stand and the kitchens that prepare the food for all the concession stands in the arena. Across the track from all this activity is the press box, and behind it, pit row.

The outer walls of all buildings have 15 DP. It takes 20 breaches to collapse the largest building, but only 8 to collapse the kitchens, VIP stands, or press box. The main grandstand would require 120 breaches before it collapsed.

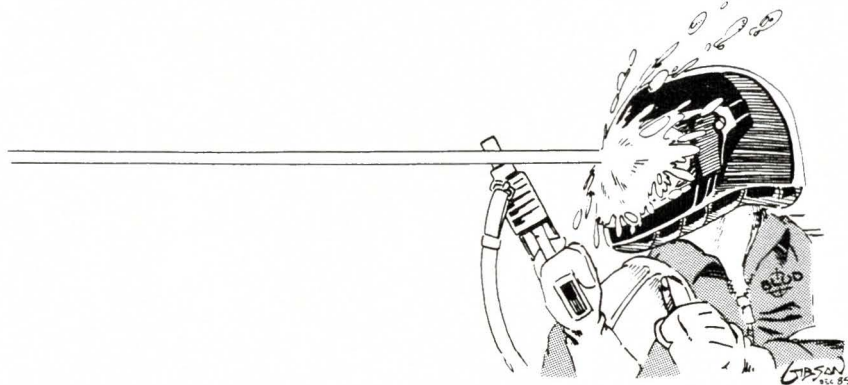

# AUTODUEL<sup>®</sup>

## Now For Your Computer

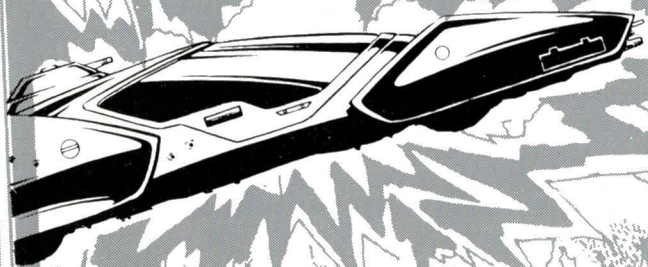

Drive the freeways of the future where the right of way goes to the biggest gun. Somewhere within the 16 cities and outlaw-infested highways are the clues you will need to complete the ultimate mission.

Step into the arena on Amateur Night and earn the right to custom-build your combat vehicles.

The AADA will offer you courier missions. The FBI and the underworld will vie for favors. But watch out! To survive you'll need road experience, the ability to decipher clues, gambling skills, money, a super car – even a clone.

The final gauntlet will test your tactical skills and hair trigger reactions to the limit. But with triumph comes honor, and entry into the elite circle of Autoduellists. The challenge of Autoduel<sup>®</sup> awaits you. Are you ready?



340 HARVEY ROAD  
MANCHESTER, NH 03103

To order by mail send \$52.00 (includes postage and handling) to: Steve Jackson Games, Box 18957-T, Austin, TX 78760. Texas residents please add \$2.67 sales tax.

# Racetrack Arenas: Fancy Passing or Passing Fancy?

by **Scott D. Haring**

Possibly the most interesting development in autoduellling in the past year has been the emergence of “racetrack” style duelling arenas. Rather than an open area with various obstacles — the long-time standard — racetrack arenas force vehicles to follow a set course. It’s a definite throwback to the glory days of 20th century auto racing — but does it work for duelling?

“There’s no doubt that there’s room in autoduellling for the racetrack style,” says Willy Archer, manager of the Baltimore JoustDuel Arena, site of the 2034-2035 AADA World Championships. “It’s got plenty of speed and action, and that’s exactly what the fans want.”

Official AADA statistics indicate that racetrack-style duels last longer than arena duels — up to twice as long. Those same statistics also bear out what the pros driving the cars already know — racetrack duelling is less deadly. “There’s less shooting and more driving,” says pro duellist Art Denmark. “And when you do drop out, it’s usually because of a crash or a roll, and that’s better than getting point-blanked by a pair of Vulcans, any day.”

Denmark and a number of fellow veterans of the racetrack circuit have nominated their five favorite courses, and we’ll profile each one. In addition, we learned some interesting things about this new style of automotive mayhem:

*Dropped weapons are a no-no.* Many events prohibit them outright, but our panel of duellists agreed that even where they weren’t outlawed specifically, no sane person would use them. “What goes around, comes around,” Denmark said. “On a circuit course, anything you drop is going to be waiting for you when you come back around.” The only dropped weapons to consider at all would be the flaming oil jet, because it is gone in just a few seconds.

*Handling counts more than firepower.* Many racetrack events are scored not on kills, but on opponents passed or laps completed.

It’s still important to knock out your fellow combatants, but staying on the track is a surer way to victory.

*More often than not, the winner is the driver who can match any situation with the best speed.* Drivers who go too slow can’t get enough laps or make passes; those who go too fast wipe out without taking a shot from an enemy. “It’s a tight call, and I still don’t always get it right,” Denmark said. “Too slow and you get left behind, too fast and you roll. It’s the single most challenging thing about it. It’s the main reason I’m still in the game.”

## THE TRACKS

*The Baltimore JoustDuel Arena.* Perhaps the best known of the racetrack style arenas, it is a logical extension of colonial Maryland’s favorite sport — jousting. Single best format is to line up two cars at opposite ends of the straightaway and let them go after one another, take the circle and come back. Crossing the center is discouraged by a double layer of mines. The key is to go as fast as possible on the straightaway, so as to give your opponent the fewest good shots. But then, you’ll have to slow down fast to avoid losing it on one of the tightest curves in duelling.

*The Evansville Four-Way.* Nicknamed “The Five-Leaf Clover,” the Evansville Four-Way looks like it was designed by a traffic engineer two bottles past drunk. Despite the remote location, the Four-Way is Indiana’s second-most-popular duelling arena, behind the Hoosier Duellodrome in Brickyard. A common format for a Four-Way event is to line up cars at the center intersection, facing outward. First to complete all four loops wins. As an added rule, weapons fire is often prohibited before the first loop is completed. Our experts say a

car with superior acceleration is often just the ticket, since rapid changes of speed are necessary to turn in the best times.

*The Macon Dragway.* Called "The Kink" by practically everyone, the Macon Dragway is a dragstrip in only the loosest sense of the word. It's true that there is a start and finish line, and the course does not complete a circuit, but the similarity ends right there. The Kink has been host to all sorts of events, including traditional, against-the-clock drag races. No-weapon events are also popular, as drivers try to force each other off the twisting course. And once amonth, teams participate in the "Macon Special" — two teams line up at opposite ends of The Kink, and the first team to get any car or member across the other team's starting line wins.

*The Brett Memorial.* Named after one of the town's 20th century heroes, Kansas City's George Brett Memorial is a large, standard oval with one twist: The backstretch loops itself into a killer of a cross-over intersection. "It's a pretty standard racetrack for the most part, but if you're not ready for the loop, it'll eat your lunch," Denmar points out. "The temptation is to go fast to reduce the amount of time you're vulnerble to T-Bones, but if you do that, you'll never make that 270-degree turn. Worst wreck I've ever had happened at the Brett. Still, the money's good, so as long as Gold Cross is paid up, I'll fight." Events at the Brett are standard racetrack fare: Group starts with restrictions on weapons fire, staggered starts, and team events.

*The Sacramento Autoduel Arena.* Nicknamed "The Camel" for obvious reasons, it's

Sacramento's fans and local regular participants that make this arena distinctive. "I've only won once at the Camel, and I consider myself lucky. That local chapter practices there day in, day out. They know every pebble, every little dip and bump. And their fans are very . . . well, efective," Denmar said. While currently enjoying full AADA approval, it should be noted that twice in the past five years the Sacramento Autoduel Arena has been placed on AADA Probationary status for failure to maintain adequate crowd control. Both probations stem from incidents where incensed fans attacked non-local duellists who happened to be winning. While no incidents of this type have been reported in several months, the reputation of Sacramento's fans is a psychological burden out-of-town duellists have a hard time overcoming.

## GAMING NOTES

Diagrams for the five "racetrack arenas" discussed in this article follow. Three of the tracks — The Sacramento Camel, The Macon Kink, and The Baltimore JoustDuel arena, can all be built with two Set 1: Starter Sets of Deluxe Road Sections. To make the Evansville Four-Way, you'll need three Set 1: Starter Sets and one Set 2: Intersections. The George Brett Memorial in Kansas City requires two Set 1: Starter Sets, and one each of Set 2: Intersections and Set 3: Straights. In a pinch, you could forget the intersections and use overlapping straights to make the four-way at the Brett.

# Baltimore Joustduel Arena

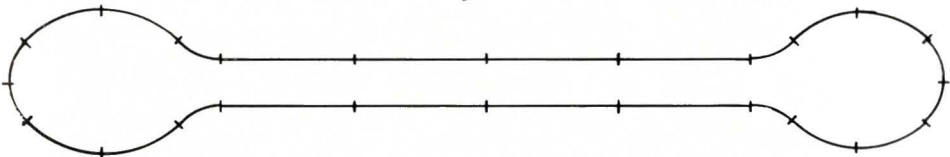
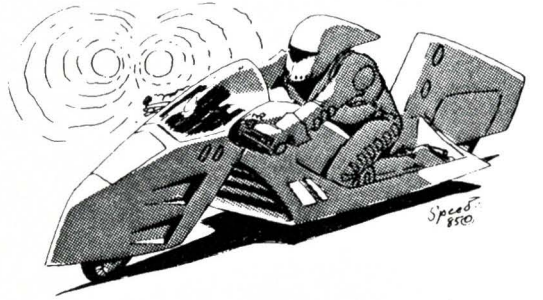

# The Evansville Four-Way

"The Five-Leaf Clover"

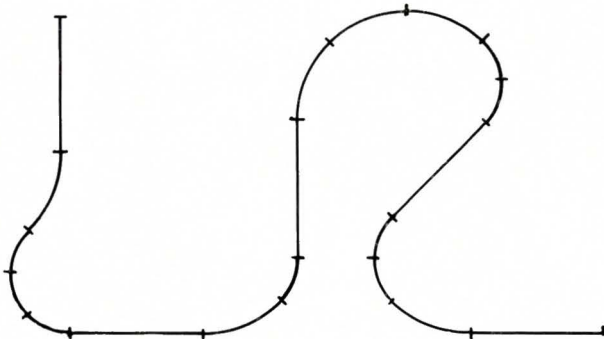
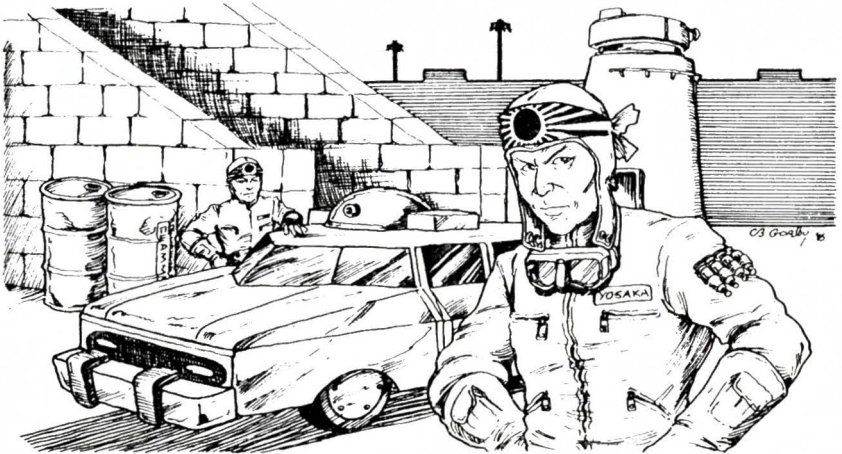
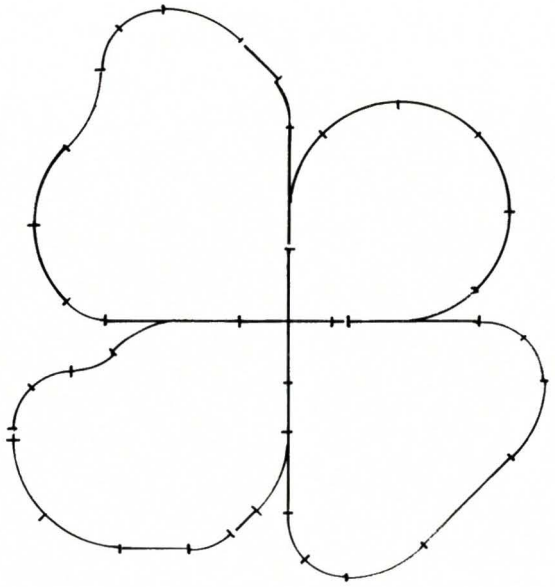

# The Macon Dragway







"The Kink"



# The Brett Memorial

Kansas City

## MAP KEY

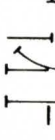
-  Short Straight
-  Straight
-  Tight Curve
-  Regular Curve
-  Turnout
-  Crossroads
-  Various overlapping road sections

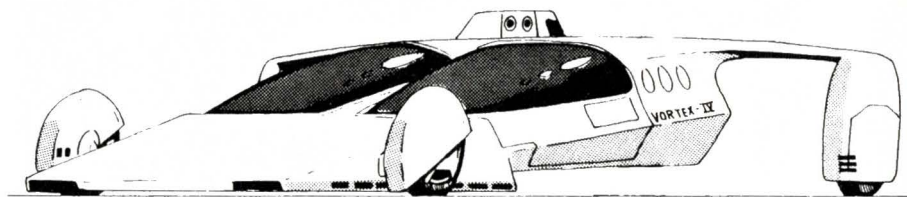
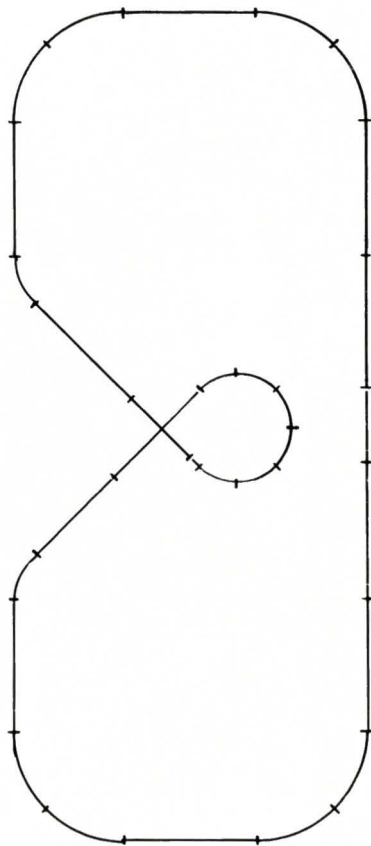

*Speed 8370*

# Sacramento Autoduel Arena

"The Camel"

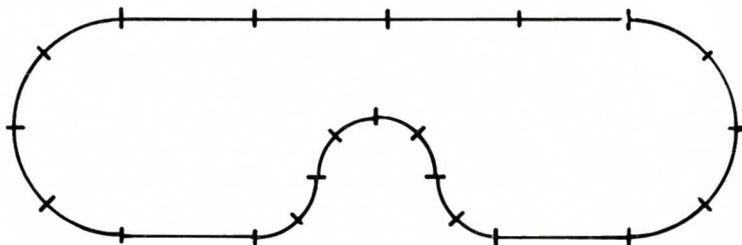



# ATLAS

# BODYWORKS

If there's one spot that duellists can't protect enough, it's their tires. Wheelguards are effective, but can get in the way if you have to do too much fancy driving. Atlas has come up with the answer — we put the armor on the *wheel itself*, and then flanged it out to protect the tire! Everyone will be wanting these beauties, so don't be left behind! Place your order today!

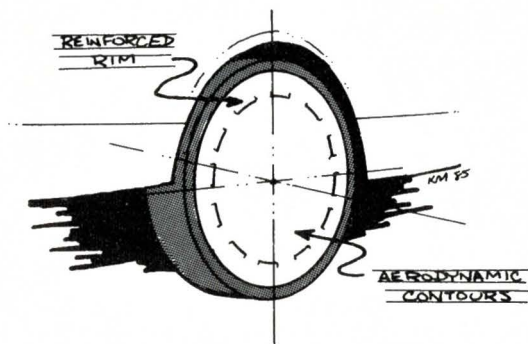

## ARMORED WHEEL HUBS

**Armored Wheel Hubs:** Can be mounted on any wheel facing the outside (not the inner wheel of a pair). Protects just like a wheelguard — when the tire is hit, roll one die; on a 1-4 the armored hub takes damage first, and on a 5-6, the hub is bypassed and the tire takes damage directly. Armored hubs cost \$15 and weigh 4 lbs. per point per wheel. Armored Hubs do not affect the HC of a vehicle in any way. Armored Hubs may be used together with wheelguards for additional protection, but the wheelguards will still affect HC as usual. When hubs and wheelguards are used together on the tire, check to see if the wheelguard stops the damage first (1-4 on 1d6). If the damage bypasses the wheelguard, then roll again to see if the armored hub stops the damage (again, 1-4 on 1d6). Only if both the wheelguard and the hub fail to stop the damage is the tire hit. Unlike the wheelguard, which stops damage from all angles, the armored hub only stops damage from the side (as defined by the target vehicle's side arc of fire).

“We specialize in protection”

## COMPONENT ARMOR

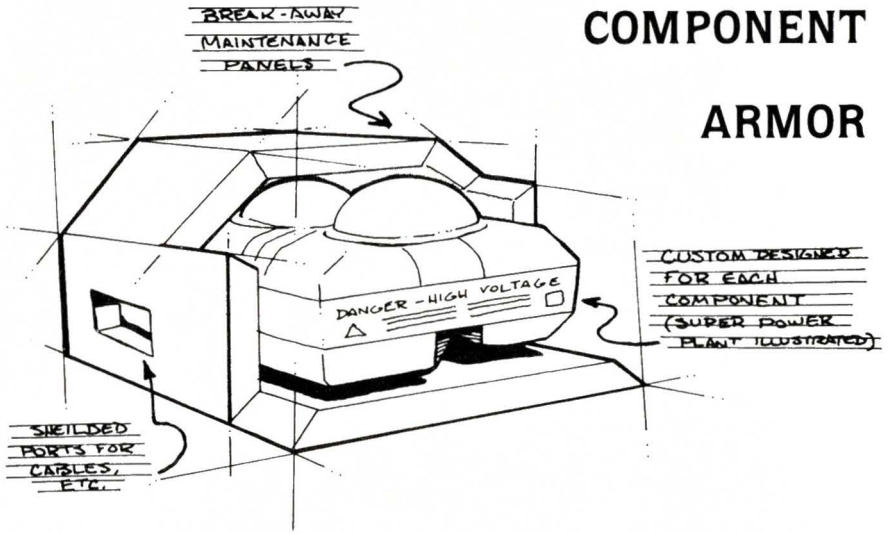

Sometimes, you want some extra protection for a special part of your vehicle — the power plant, or a favorite weapon, or even yourself. Atlas now lets you do it with Component Armor — specially crafted to provide full protection from all angles in all sorts of tight places! For that extra added measure of safety, Atlas' Component Armor can't be beat!

Component Armor: Assigned to any one vehicular component, it costs \$5 and weighs 2 lbs. per point per space the component being protected takes up. (Example: Protecting a super power plant — 6 spaces — costs \$30 and weighs 12 lbs. per point; armor for a laser — 2 spaces — costs \$10 and weighs 4 lbs. per point.) The armor also takes up a space for every 10 points (or fraction thereof) of protection. That is, 10 points of armor takes up one space, 11-20 points takes up two spaces, etc. The armor is universal, providing full protection from all angles — effectively, it increases the DP of the component in question. Extra magazines must be armored with the associated weapon, and laser batteries and other items attached to the power plant must be armored with the plant. Cannot be used to protect weapons in External Weapon Pods, but can protect turreted weapons and anything else in a vehicle. To protect items that take up no space (like computers), calculate the cost as if the component took up one space.

I don't have just oodles of room in this issue, so I'll keep the introduction short. We have five new chapters, and a brand new regional line-up! It'll all be listed at the end of the column. But first, lots of news from the chapters:

NOVA held a tournament at OmaCon 5, with David MacKinnon coming out on top as Richard Baker and Blair Van Brisen eliminated each other in a hand weapon duel before MacKinnon could get over to the action. Baker was awarded second, and Van Brisen third. NOVA has also published *Starburst*, the first of what they plan to be a quarterly newsletter. The first issue offered a detailed account of the OmaCon 5 duel, plus an account of a running problem NOVA has been having with both EDSEL and ARF forces. It's a nice piece of work. Keep it up . . .

The Canton Autoduel Association ("The Precision Mechanism," they call themselves) held their 2034-2035 Club Championship July 4th at the Akron Rubber Bowl. Robert "Pyro" Rolf came out on top, and has received a prize from Steve Jackson Games. Rolf chalked up 4 confirmed kills in the three-battle tournament. The team of Steve and Scott Buchheit finished second, followed by The Sheik Clark and J. L. Dugger.

The NOMADS report that they wiped out the Arcadia Autoduel Association in a 20-second duel on August 11. Arcadia representatives admit the duel went badly, but claim the disbanding of their club has nothing to do with the results of the duel, but instead is due to pressing educational commitments (i.e., they all went off to college).

DEATH has two battles to report. One involves their Club Championship held at the Dumbarton Slalom Arena. Robert "Terminator" Thielemann used sound strategy and conservative tactics to place himself in a position to win at the end, and then charged across the finish line to take the victory.

The following is taken verbatim from DEATH's last communique, titled, "DEATH vs. the Arlington Autoduel Association":

In four-car teams, the two clubs clashed in the Armadillo Autoduel Arena. The two club presidents (David Wilson of DEATH and Larry Lauanders of AAA) served as referees. DEATH's victory was one of the most spectacular since Napoleon at Austerlitz. The AAA vehicles split up on the attack while the DEATH vehicles stayed together and eliminated the opposition one by one. The last AAA driver surrendered rather than face certain extinction at the guns of all four DEATH vehicles. In the end, no DEATH vehicle had taken over 15 hits of damage (one hadn't been hit at all!), while three of the AAA vehicles had been utterly gutted, the fourth surrendering. The prize for the winning club was to do the write-up for *ADQ*; however, I assure you that I have not over-stated DEATH's amazing victory over the extremely embarrassed AAA, who lacked a plan or any sort of cohesiveness in battle. To the victor go the spoils, though. DEATH won because of extensive practice and cooperation, something the opposition lacked. The price limit on each car was \$20,000, and AAA insisted on a "no-laser" rule, which DEATH reluctantly agreed to.

It should be noted that the Arlington Autoduel Association has let their AADA membership lapse, though we hope that the action described above was not solely responsible.

Steven Huntsberry of the Marin Marauders reports that he took first place at a Division 15 Off-Road event held at the Ozark Off-Road Autoduel Arena. Huntsberry defeated two other vehicles for the win, despite having his gunner drop a live grenade in the interior of their trike in the very first second of the duel! "Lucky we had body armor, or it would have been all over in the first second," Huntsberry reported.

The Black Death Autoduel Association, our only Canadian affiliate of the current roster, is doing something a little different. Each member is playing a corporation, with a fleet of vehicles and team of characters per player. Each corporation decides whether to allocate limited resources toward equipment or personnel, and spends prize money to improve their machines and protect their people. Their latest event was the Gasso Invitational Rig Duel, with a \$300,000 limit on a fighting rig and a \$750,000 first prize. Son of Ghost of Don, driving a Demons Talos XH RL 56 for the BAAMACO team, took first. O.P.E.C.

(Organization of People Expecting large amounts of Cash) hosted an off-road event that was crashed by notorious criminal Scuz Kickenbucket, who lived up to his name, with the help of many of the competitors.

The corporate approach is an interesting one, and another chapter has picked it up. The River City ADA (formerly the Austin Autoduel Association) is meeting regularly and using a corporate/team set-up. The River City ADA is meeting regularly at their new sponsor, Hexworld, a gaming center in Austin.

That's it on the news front. Keep sending those reports in — let your fellow duellists know what you're up to!

## CLUB ROSTER

Here's a complete list of AADA chapters, divided into regions, as of November 15, 2035 (new chapters are marked with an asterisk):

### EAST REGION

Black Death Autoduel Association  
Mad Al Loud, President  
501 Kingston Road #105  
Toronto, Ontario  
Canada M4L 1V7

Canton Autoduel Association  
James Davenport, President  
4229 Bellwood Dr. NW  
Canton, OH 44708

Central Massachusetts Crusaders  
Russel Heller, President  
29 Princeton Rd.  
Sterling, MA 01564

### NORTH REGION

The Beer Town Boys  
Jacob Abrams, President  
1638 N. Armington Pl.  
Milwaukee, WI 53202

The Cook County Autoduel Association  
Ray Ciscon, President  
10247 S. 82nd Ct.  
Palos Hills, IL 60465

Land of Lincoln Autoduel Association  
Russel McKinney, President

1407 Scottswood Rd.  
Rockford, IL 61107

\*Minneapolis Autoduel Association  
Chris Yue, President  
3319 Humboldt Ave. S.  
Minneapolis, MN 55408

### MIDWEST REGION

\*Manhattan Organization of Autoduellists  
(MOAD)  
Jimmy R. Jones, President  
P.O. Box 456  
Manhattan, KS 66502

New Omaha Vehicular Association (NOVA)  
Norman McMullen, President  
2201 Joyce Circle  
Bellevue, NE 68005

Southside Chapter of the American Auto-  
duelling Association — Tulsa  
(SCAADAT)  
Stacey Duis, President  
4815 E. 35th St.  
Tulsa, OK 74135

Tulsa Overt Operations for the Betterment of  
Autoduelling (TOO-BAD)  
Carl Neal, President  
5930 E. 25th St.  
Tulsa, OK 74114



## TEXAS REGION

\*Lubbock United National Autoduellists,  
Truckers, and Insane Cyclists  
(LUNATIC)  
Matt Way, President  
3311 41st St.  
Lubbock, TX 79413

\*River City Autoduel Association  
Tim Ray, President  
8910 Research, #C-2  
Austin, TX 78758

Duellists, Experts, Aces, and Terminators  
for Hire (DEATH)  
David Wilson, President  
37 Yorkshire  
Bedford, TX 76021

## CALIFORNIA SOUTH REGION

\*Autoduel Brotherhood of the Southern  
California Axe Murderers (ABSCAM)  
Bryan Fear, President  
17065 W. Bernardo Dr.  
San Diego, CA 92127

North American Mondo And Duellist Society  
(NOMADS)  
Dulio Ramallo, President  
1652 Oakhome Dr.  
Harbor City, CA 90710

## CALIFORNIA NORTH REGION

Berkeley Autoduelling Association  
Ray Churchfield, President  
2819 Milvia  
Berkeley, CA 94703

Carmel Autoduel Association  
Curt Graham, President  
Rt. 1, Box 231  
Carmel, CA 93923

Sacramento Area Autoduel Association  
James Worth, President  
6636 Rinconada Dr.  
Citrus Heights, CA 95610

## NORTHWEST REGION

Marin Marauders  
Steven Huntsberry, President

27 River Oaks Rd.  
San Rafael, CA 94901

NorCal Transit Authority  
Michael Taber, President  
36 Laurel Ave.  
Petaluma, CA 94952

\*Society for Protection of American Road-  
ways (SPAR)  
Rich Hindman, President  
1884 Melody Drive  
Idaho Falls, ID 83402

Spokane Society for Vehicular Combat  
Karl Erickson, President  
13608 E. 7th  
Spokane, WA 99216

## AT-LARGE REGION

\*Royal Autoduelling Association of Australia  
Gary Makin, President  
32 Mary Street  
Northmead  
Sydney, Australia 2152

STATEMENT OF OWNERSHIP, MANAGEMENT AND CIRCULATION			
1. TITLE OF PUBLICATION		2. PUBLICATION NO.	
AUTODUEL QUARTERLY		0 7 4 0 3 3 5 0	
3. FREQUENCY OF ISSUE		4. DATE OF FILING	
Quarterly		0 27 Sept 1985	
5. COMPLETE MAILING ADDRESS OF KNOWN OFFICE OF PUBLICATION (Street City, County, State and Zip Code - No Post Office)		6. NO. OF COPIES PUBLISHED	
P O Box 18957, Austin, Travis County, Texas 78760-8957		ANNUALLY 4 PRICE \$10.00	
7. COMPLETE MAILING ADDRESS OF THE HEADQUARTERS OF GENERAL BUSINESS OFFICE OF THE PUBLISHER (Post Office)		8. FULL NAME AND COMPLETE MAILING ADDRESS OF PUBLISHER, EDITOR, AND MANAGING EDITOR (For item MUST NOT be blank)	
P O Box 18957, Austin, Travis County, Texas 78760-8957		PUBLISHER (Name and Complete Mailing Address)	
Steve Jackson, P O Box 18957, Austin, Texas 78760-8957		EDITOR (Name and Complete Mailing Address)	
Scott Haring, P O Box 18957, Austin, Texas 78760-8957		MANAGING EDITOR (Name and Complete Mailing Address)	
-- NONE --		-- NONE --	
9. OWNER (If owned by a corporation, its name and address must be stated and also immediately thereunder the names and addresses of stockholders owning or holding 1 percent or more of the amount of stock. If not owned by a corporation, the names and addresses of the individual owners must be given. If owned by a partnership or other unincorporated firm, its name and address, as well as that of each individual must be given. If the publication is published by a corporation, its name and address must be stated. (Form must be completed.)			
FULL NAME		COMPLETE MAILING ADDRESS	
Owned by Steve Jackson Games Incorporated		Steve Jackson Games Inc	
by Steve Jackson		P O Box 18957	
P O Box 18957		Austin, TX 78760-8957	
Austin, Texas 78760			
10. KNOWN BONDHOLDERS, MORTGAGEES, AND OTHER SECURTY HOLDERS OWNING OR HOLDING PERCENT OR MORE OF TOTAL AMOUNT OF BONDS, MORTGAGES OR OTHER SECURITIES (If there are none, so state)			
FULL NAME		COMPLETE MAILING ADDRESS	
-- NONE --		-- NONE --	
11. FOR COMPLETION BY NONPROFIT ORGANIZATIONS AUTHORIZED TO MAIL AT SPECIAL RATES (See item 4.2.2. (2) (b) (iii) only)			
The purpose, function, and nonprofit status of this organization and the exempt status for Federal income tax purposes: (Check one)			
<input type="checkbox"/> HAS NOT CHANGED DURING PRECEDING 12 MONTHS <input type="checkbox"/> HAS CHANGED DURING PRECEDING 12 MONTHS         (If changed, publisher must submit explanation of change with this statement)			
12. EXTENT AND NATURE OF CIRCULATION (See instructions on reverse)		13. AVERAGE NO. COPIES EACH ISSUE DURING PRECEDING 12 MONTHS	
A. TOTAL NO. COPIES (Net Press Run)		11625	
B. PAID AND/OR REQUESTED CIRCULATION		12500	
1. Sales through dealers and carries, street vendors and counter sales		8442	
2. Paid distribution by mail (Include paid distribution by mail)		1691	
3. Paid distribution by other means (Samples, complimentary, and other free copies)		1952	
C. TOTAL PAID AND/OR REQUESTED CIRCULATION (Sum of B. 1, 2, and 3)		10133	
D. FREE DISTRIBUTION BY MAIL, CARRIER OR OTHER MEANS (Samples, complimentary, and other free copies)		204	
E. TOTAL DISTRIBUTION (Sum of C. and D.)		10337	
F. COPIES NOT DISTRIBUTED		9009	
1. Office use, left overs, unreturned second class mailings		1210	
2. Returns from News Agents		78	
G. TOTAL (Sum of E, F. 1 and 2. Should equal net press run shown in 12.)		11625	
H. ACTUAL NO. COPIES EACH ISSUE PUBLISHED (Sum of E and F. 2)		12500	
14. I certify that the statements made by me above are correct and complete			
SIGNATURE AND TITLE OF PUBLISHER, BUSINESS MANAGER, OR OWNER		EDITOR	
Steve Jackson		Editor	

# Ramps in Car Wars

## Adding the Third Dimension

by Glenn A. Austin

This article wouldn't be here right now if it weren't for someone else's misfortune. I had submitted an event to GenCon 18, but it was turned down, so when I got a call asking me whether or not I would like to run "Collegiate *Car Wars*," I said yes. Two days later, GenCon called me again and told me that not only couldn't the guy show up, but he hadn't designed his event, and I had to make it from scratch in the next 30 days.

Being a lazy sort, I didn't sit down and put my nose to the grindstone right away. I waited until I had 10 days left (sometimes I'm not too bright). Grabbing a notebook and *The AADA Vehicle Guide* (SJG), I went through and picked a \$40,000 team of cars for each player. Half of the sets of

cars went to offense, and half to defense. (The scenario of CCW is one college attacking another). Bravo! I had some cars for my players!

Well, the person who had submitted the event had designated 3 things. One, the rules were to be taught to the players on the spot (some wouldn't know how to play *Car Wars*). Two, it had to be on "an arena-type battlefield" (on campus? what was I supposed to use? a parking lot?). Three, the game had been allotted three hours and forty-five minutes to run.

To solve the first problem, I decided that since this was a team event, I would put at least one player who knew the rules on each team, so he would help his less knowledgeable team-mates out.

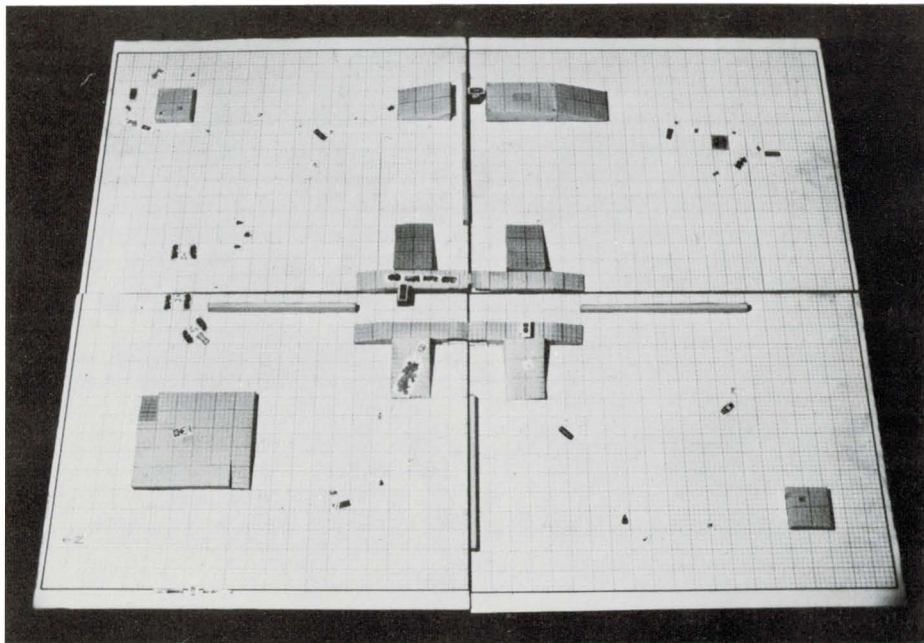

The layout of the arena at GenCon 18.

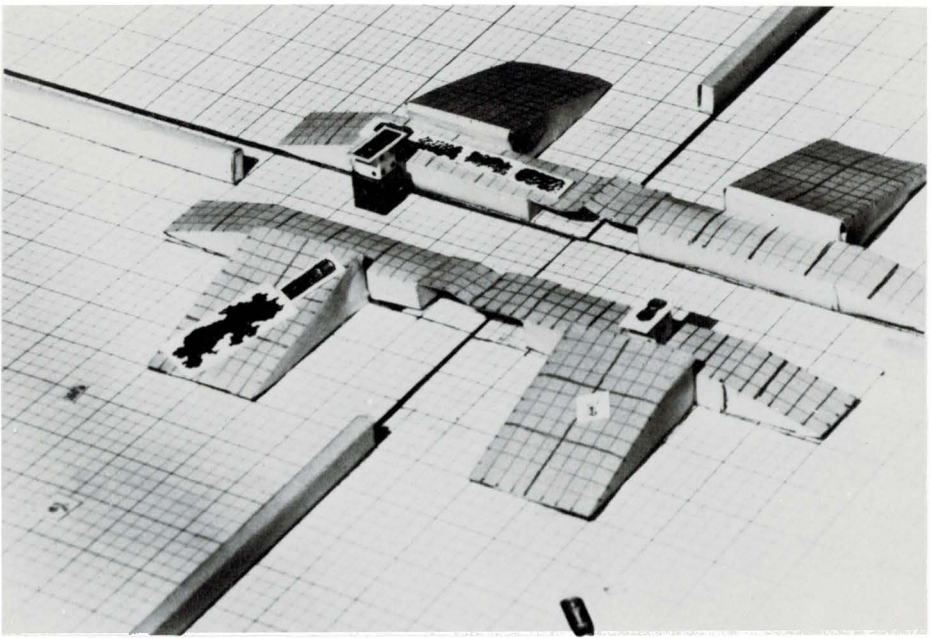

This double jump also has a pair of overpasses in the center.

To solve the second, I bought two *Car Wars Map Sheets* (SJG), cut both in half, and mounted each of the four pieces on cardboard with spray adhesive. I then trimmed the edges. I now had a large arena which could be set up by laying the 4 mounted parts of the map next to each other. The annoyance of the folded maps that had creases in them had been eliminated!

To solve the third problem, I produced a speed chart for each of the players. That way, I would only have to call out the phase; each player would keep track of his own speed and HC. (This makes the game move a lot faster.) I would be needed if a player's HC went below 0, or if there were weapons fired.

I sat back and surveyed my handiwork. I had car sheets for each of my players, a faster way to run the game, and a *boring* "arena-type battlefield." What could I do to make the arena more interesting? Well, to start with, I renamed it. It became the college autodueling team's practice

field. Then I had the inspiration that makes this article possible. **I made 3D ramps, buildings and overpasses and glued them to the board.**

Constructing ramps and overpasses is not very hard. I got some construction paper (I used yellow) and drew some layouts for fold-up buildings and ramps, cut them out, folded them, and glued them to the map. With this article are some samples, including a basic 3'' x 2'' ramp.

The hardest 3D construction to make was the ramp. If the area a ramp is going to cover is 3'' x 22'', then the actual length of the ramp surface is going to be 3.16 inches. (For mathematicians, this comes from Pythagorean's Theorem,  $A^2 + B^2 = C^2$ .) If you're going to construct your own ramp, get a calculator. Find out how long an area the ramp will cover and square that distance (multiply by itself). Write the result down. Then find out how high the ramp is going to be when it reaches the end and square this number



also. Take the square root of the sum of the first squared number and the second squared number. You now know how long to make your ramp surface.

Example: Joe wants to make a ramp that will cover 6 inches by 2 inches of his map and will be 2 inches high at the end. He squares 6 and gets 36. Then he squares 2 and gets 4. Adding these numbers together gives him 40. The square root of 40 is 6.32. His ramp surface will be 6.32 inches by 2 inches.

Included with this article are a basic ramp, an overpass, and a small bunker. If you're in a hurry, just copy my ramp, and you can avoid the math.

Ramps are all very well and good, but the only rules we have for them are in *The AADA Vehicle Guide* that I mentioned earlier, and those are for off-road. These are my recommendations.

**Jumping Distance** — When a vehicle leaves a ramp, it will travel  $\frac{1}{2}$ " for every 5 mph it is travelling above 20 mph. (If there is no opposing ramp, the vehicle will go an additional inch for every inch it

is above the ground when it leaves the ramp.)

**Landing Hazard** — The hazard that a vehicle takes when it lands depends on how far it flew. For every 2" that the vehicle flew there is a D1 hazard. If the vehicle lands on a downward slope (such as an opposing ramp), there is an additional D2 hazard. If it hits the opposing ramp at exactly the speed needed to make the jump, D1 is subtracted from this hazard. (Example: For two opposing ramps, three inches away from each other, the speed would be 50.) If the car lands on a flat surface, there is a D1 hazard. If it lands on an upward slope, there is no hazard beyond that incurred by the distance jumped. If the car fails its control roll, each tire will take 3 points of damage in addition to any other penalties.

**Falling Short** — If the vehicle is going too slow to make it to the opposing ramp, the front armor will take ram damage at the speed the car is going, and an additional 2 dice for every  $\frac{1}{2}$  inch it is above the ground. Each tire will take 1 die of

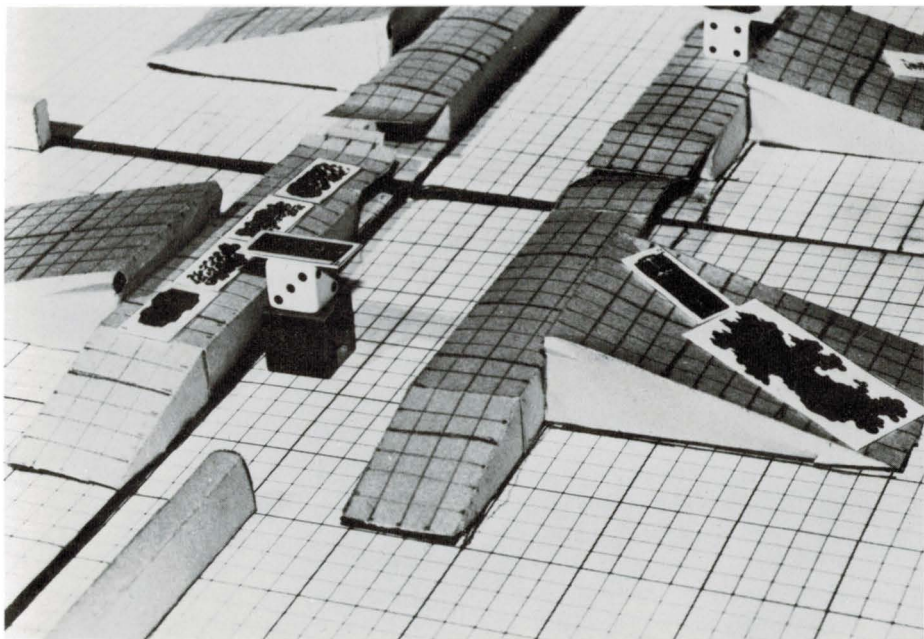

Stacked dice are very handy for simulating a flying vehicle.

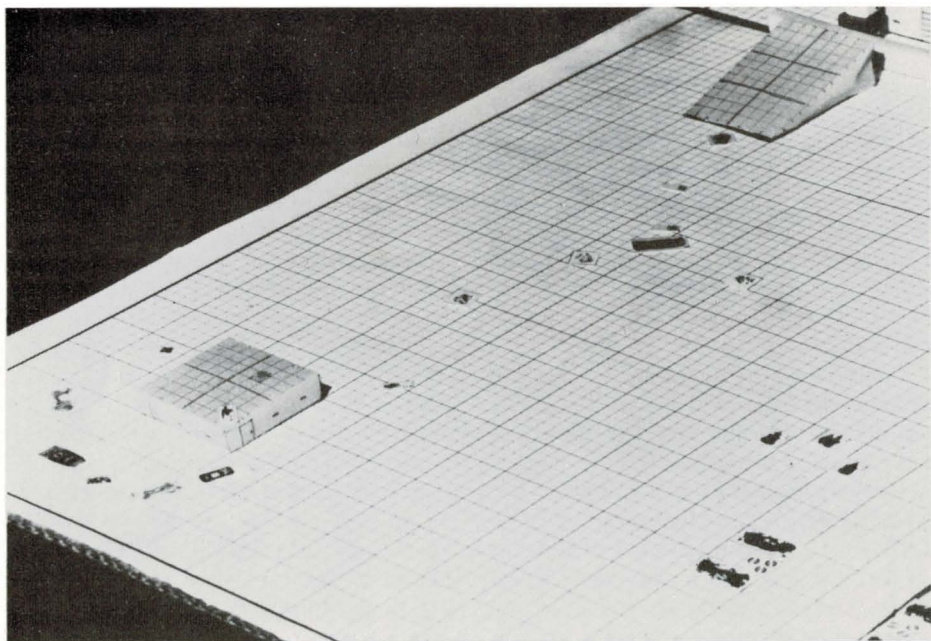

### A bunker in the corner is a lifesaver for pedestrians . . .

damage, and the car will end up at zero miles per hour facing the opposing ramp. (If there is no opposing ramp, the car was probably trying to jump over something. If it fails, it lands in what it was trying to jump over. Deal with this as nastily as you feel appropriate.)

**Evening Out** — After a car leaves a sloping surface, it will find itself out of alignment with the squares beneath it. If the player wishes to align his car with the squares, as in the “evening out” maneuver, he can do so with no hazard, but he must bring his car *towards the slope he just left*. (In other words, making the distance he has traveled shorter.)

**Targeting** — A car in the air can be hit as if it were a helicopter. The car’s underbody can be targeted if it is in a weapon’s arc of fire. A car in the air can target other cars at no additional penalty, but will be unable to use a turret. It can target another car’s top armor, but only if that armor is in the weapon’s arc of fire.

**Jumping Benefits** — Some arenas offer cash bonuses to the winner if he has

made jumps during the combat, and there is an automatic +1 to prestige and driver skill for every jump made successfully.

**Bottom-Mounted Weaponry** — I allow bottom-mounted weapons, bombs and bottom turrets. If cars with bottom-mounted turrets go off-road, however, the turret is torn off. If the underbody armor is stripped, and there is a bottom-mounted bomb which takes damage, roll a die. If the result is 1, 2, or 3 the bomb explodes, destroying the car.

**Acceleration and Deceleration** — When driving up a ramp, acceleration is 5 mph less than normal, deceleration 5 mph more. When driving down one, acceleration is 5 mph more, and deceleration is 5 mph less.

If you have trouble getting your players to go over jumps, there are three things that I suggest you try. 1) Don’t give them an alternative. If they want to go from point A to point B, the only way to do so is to make a jump. 2) Give them an alternative, but make it unpleasant. Fill it with debris, make it far away (so

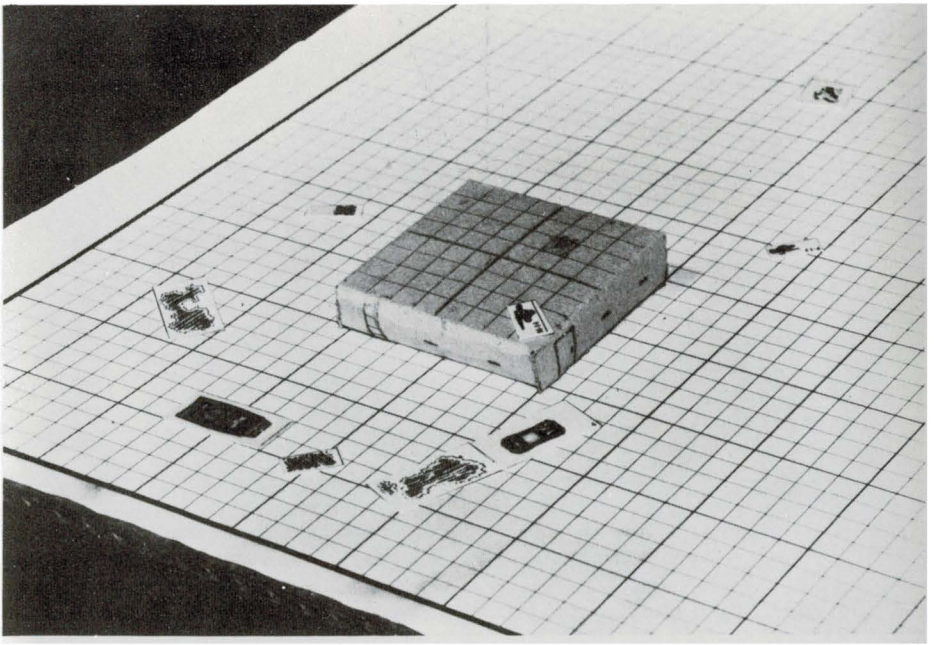

Or they can be used to launch additional attacks.

that it wastes a lot of time), or give them a prestige penalty for chickening out. 3) Make it go over a route that lots of cars take, so they can fire on them and drop stuff.

As a parting statement, I would like to congratulate those that participated in my event. Real masters of mayhem, they littered the field with more debris than I have ever seen.

### Bunker

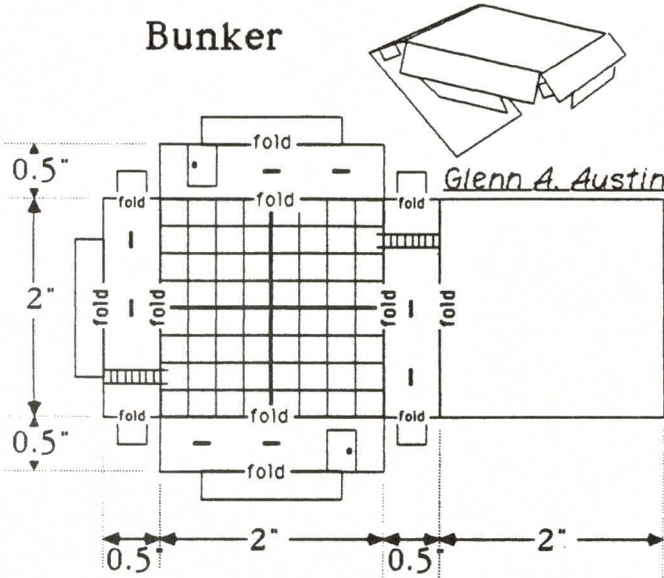

## Basic Ramp

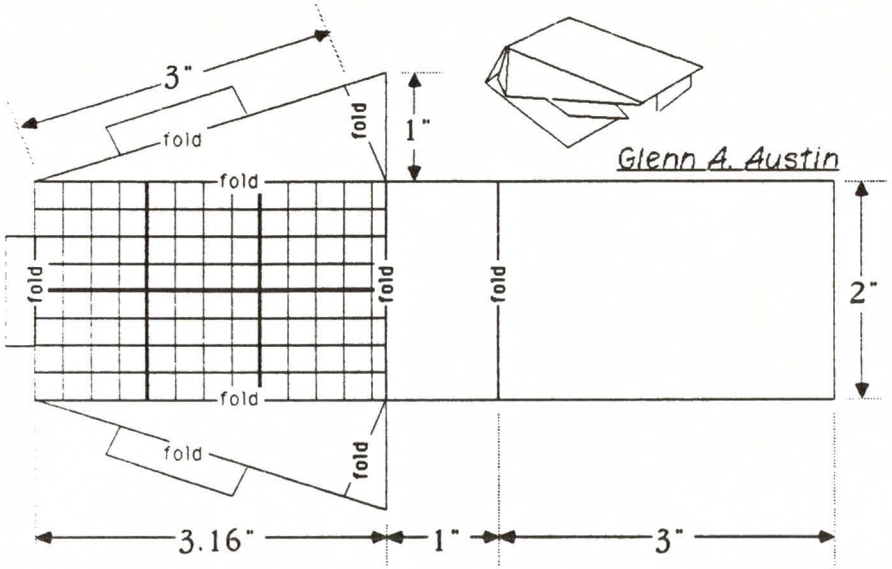

## Overpass

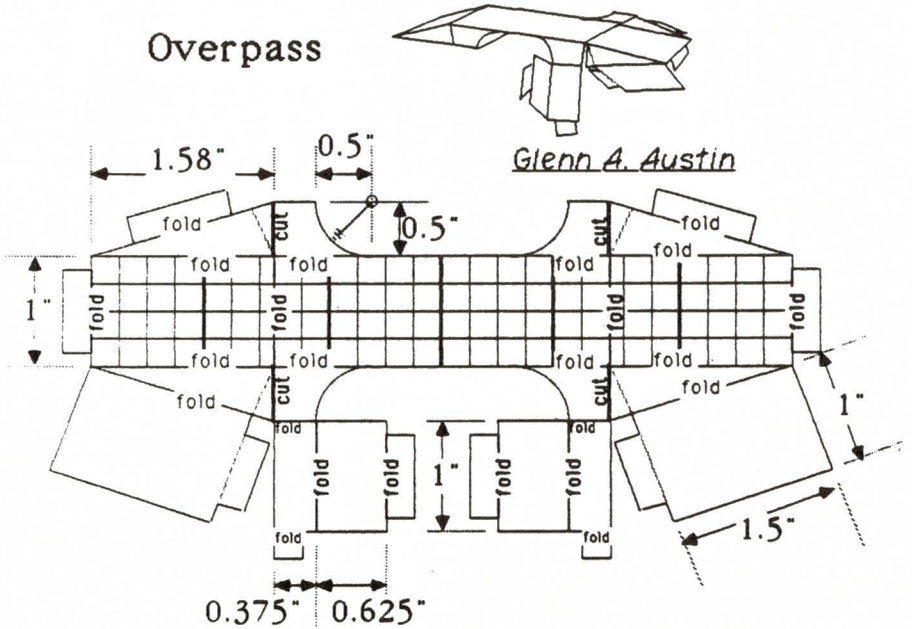

# Backfire

Last week I was driving my brown Lynx to school, when I was involved in (OK . . . when I *caused*) a minor accident which did about \$25 in damage to the other car and no injury. Even though there was no screaming and I agreed to pay for the damages, we agreed that it would be a good idea to call the police and fill out a minor accident form.

The officer arrived and asked to see my car. Since I was at fault, I was being as polite and agreeable as I possibly could (it pays: As I said before, the whole thing was carried off quite amiably). As the officer walked towards my car, my heart sank.

On the back bumper was an innocuous red-and-white sticker saying *Shoot if you Love Autoduelling*.

The officer, thank God, did not comment on it. ("Well, you see, officer, it's a board-game using these little cardboard counters and I write for the magazine . . . no, I wouldn't mind coming along to the station.") But it was about two hours before I saw any humor in the situation.

I was pleasantly surprised to see you decided to publish "Kamicars": thank you. I haven't had enough time to really read the magazine yet, but I was struck enough by Helzer's magnificent letter to start writing back now. (Ed. note: *Both appeared in ADQ 3/3.*)

The points raised by Mr. Helzer are very good ones and I'm glad to see someone taking a serious and critical look at this fictional society. I don't disagree with anything he has to say except for his timing.

I believe it is possible for the society outlined in *Car Wars* to exist. Firstly, the gladiatorial games at Rome continued well past the fall of the Empire as a sort of social appendix. Once autoduelling exists, it would form an NRA-style lobby which would certainly be able to maintain its legality for a good long time. Also, I don't believe autoduelling would actually be as deadly as it often games out to be: A professional duellist would surrender immediately upon realizing the situation was getting away from him (anyone who continues

to fight in a car which has a 17% chance of blowing up each second is suicidal. They can't be that dumb). This could, by the way, account for the popularity of amateur night: These guys don't know when they've lost and stop only when they die. Nice bloody combats.

Yes, I can see that the cycle gangs are on their way out: But that doesn't mean they've gone yet. Especially if you assume that most of the population outside the cities are dancing on the edge of starvation like the villagers in "Doppelganger" or *The Magnificent Seven*. As a matter of fact, the reason that movie took place mostly in Mexico was that, historically, any bandit gang which attacked a US village (where most of the adult male population were veterans of the Civil War) *would* have gotten their backsides blown off. However, I suggest that a cycle gang armed with M-60s as light weapons would, proportionally, be much more dangerous than a gang of hoss-ridin' six-shooters.

And that's basically the point: The cycle gangs will exist for as long as they maintain a dramatic firepower advantage over the average civilian. A decent shot with a decent rifle firing from an emplaced position can cause real headaches for banditos riding horses and armed with six-guns and similar rifles because they can't be as accurate at range as he is and they are vulnerable to his bullets. The same gunner with the same rifle will have a lot of trouble stopping a motorcycle club with armored fairings and wheelguards.

Why are cyclists so easy for players to stomp? Because players are not average citizens — they are duellists or members of the Brotherhood, mounting more firepower than infantry squads of the Second World War. They are the modern warrior elite, and to cross them is to risk destruction.

Thank you for sending me the copy of *ADQ 3/2*. As it happens, it arrived in time to make a good day terrific. Frankly, though, I must admit a certain desire to address commentary to Paul Radecki of South Bend, IN.

Mr. Radecki, a helicopter expansion set containing all the stats published in *Autoduel Champions* would probably be about five pages long. I really don't think there's enough about helicopters to justify publication as a separate rulebook. I could be wrong, though, in which case I and the other *Autoduel Champions* owners would have no possible objection to it. I will admit, however, that I play both Hero System and *Car Wars* and I can understand your

reluctance to purchase *Autoduel Champions*.

I'm certain that comment about "most people of reasonably high intelligence" giving up on superheroes by "the age of eight" has elicited some response. Frankly, from my experience, the reverse is true: Comic collectors tend to be people of reasonably high intelligence. There are enough of us to support *Champions*, many comic conventions each year, and a whole slew of "Ground Level" publishing houses.

Finally, I do eat quiche. So does Nightsword. What's it to ya?

—John Nowak  
LaGrangeville, NY

*Both you and Helzer raise good points. I just received a much longer treatment of the entire question in the mail today, and it's quite good — look for it in issue 4/1. Oh, and those of you wondering about "Shoot if you Love Autoduelling" bumper stickers — that's what we're sending to subscribers as a free bonus this year.*

—SDH

PLEASE put this in *ADQ* 3/4. I have a friend who runs a BBS (bulletin board system) on his Apple 2e, and he has given me 3 sub-boards to work with. I am making these *Car Wars* discussion boards — one for weapon design, another for vehicle design and other stuff, and a never-ending *Car Wars* fiction board. It really hasn't gotten quite off the ground yet, but I'd like you to publish these stats in the next *ADQ* so anyone/everyone can call and put in their two cents' worth. It also gives opportunities for weapon playtesting



reviews. Periodically, I will send in these designs for *ADQ*'s use.

Here's the info: Planes of Armageddon BBS, (415) 254-0863, 300/1200 Baud, Open 24 hrs.

Tell them it is also a regular bulletin board. If you call, leave mail to account #69 (Baron Harkonnen).

—Andy Lloyd  
Orinda, CA

Since the publication of your summer (or second spring) *ADQ*, highway duels involving our club have increased tenfold. Our colors are orange, black, and white, and though we are not affiliated with the AADA (due to a lack of core duellists), neither are we associated with BLUD. Please remind your readers to confirm a target before opening fire. We do not like to blast cars into little piles of debris every time we go to the supermarket.

—Kenneth Wheeler  
President, C.I.T.A.D.E.L.

Help! I, David Feuer, more commonly known as The Phantom, am *Desperate*. I am looking for a copy of *Autoduel Quarterly(s)* Vol. 1, No. 1; Vol. 1, No. 2; Vol. 2, No. 1. If anybody out there reading this has one that they want to sell that is in good condition, I will pay very well for it. Write: David Feuer, 14 Heller Ct., Dix Hills, NY 11746. For issues in very good condition I will pay as much as \$15.

Also, will anybody in the Long Island area be interested in starting a really good, serious organization? If so, write.

—David Feuer, The Phantom  
Dix Hills, NY

P.S. Having just gotten back from a European vacation I would like to inform the general public of the United States that people in Europe drive like madmen with death wishes!

*I normally don't run letters like this, but I'm making an exception to make an example. This is exactly the kind of thing that our new Autoduel Classifieds will help you with. Starting next issue, we'll run small, personal ads for just this sort of thing — requests for out-of-print material, opponents wanted, even clubs trying to form! We'll even run them free. Just send your ad in to us at the regular address and tell us it's for Autoduel Classified. Keep it clean, and keep it short, and we'll do the rest.*

—SDH

I really love *ADQ* and I think you guys are doing a fantastic job. But in Vol. 3, No. 2, on page 8, there seems to be an amazing similarity between the Gauss Gun and the Flechette Gun to those exact weapons in *Space Opera* by Fantasy Games Unlimited, Inc. Don't get me wrong, the weapons are great for *Car Wars*, but give Edward E. Simbalist his due. The creation of these weapons is not new, only the modification to *Car Wars* rules.

—Rob O'Knefski  
Naples, FL

*Oops. Some of you may find this hard to believe, but I've never read a copy of Space Opera. I can't say whether the contributors who sent in those designs had seen them there or not. Both items are well established in science fiction, however, and their recurrence in more than one game should not be surprising.*

—SDH

I am the humble spokesman for a small but loyal band of true believers in the revelation of *Car Wars*; in fact, we find ourselves called to

spread the good news, to become *Car Wars* missionaries and evangelists. But first we need a sign from Steve Jackson Games, the holy of holies of our faith. The sign we await is the publishing of a supplement or substantial *ADQ* article fleshing out the remaining important aspects of "Chassis and Crossbow" (*ADQ 1/3*) that were so tragically overlooked. What about trucks (both tractor-trailer and mid-sized), buses, power plant options (superchargers, nitrous oxide, et al, that would be very rare but nevertheless in existence), body modifications (for handling or defense — probably jury-rigged, of course), and other things that the high priests in their infinite wisdom will undoubtedly come up with? We await this sign with all the dedicated fervor of fanaticism. Of course, would it not be forthcoming we might become disillusioned and fall into *Car Wars* heresy . . .

—Will Montgomery  
Pomona, CA

*Have Faith. For coming soon in 2036 shall be Dueltrack, the answer to your prayers, available at a hobby shop near you . . .*

—SDH

## DELIVERANCE

Courier has been the number one name in cargo and delivery vehicles since 2029. Staying on top requires hard work and constant innovation, and the new Deliverance is proof that Courier's still got what it takes. An ideal delivery vehicle for small- to medium-sized cargoes, the Deliverance is packed with defensive accessories. Mini-Safe is available for small and extra valuable cargo. It's surprisingly nimble for a van, and still manages to pack significant firepower to all quadrants! For safety and security for you and your cargo, Deliverance and Courier are the only names you need to remember.

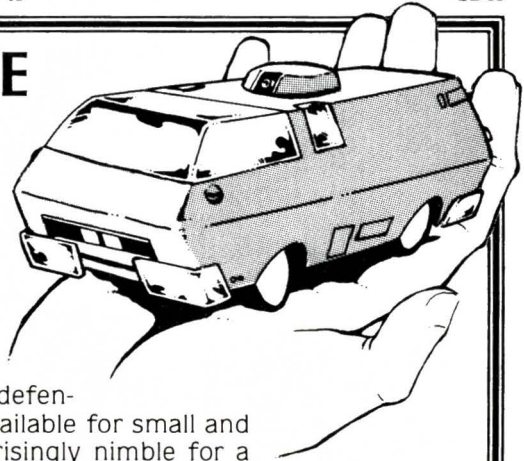

Deliverance — Van, x-hvy. chassis, hvy. suspension, active suspension system, super power plant, 6 solid tires, driver and gunner. RR in turret, extra RR magazine, 2 linked MGs front with high-density ammo, MD back, gas streamer (smoke loads) back, flaming oil jet back, improved fire extinguisher, 2 hi-res computers, mini-safe. Laser-reflective fireproof armor: F20, L20, R20, B15, T10, U5. Cargo capacity: 9 spaces, 169 lbs with Mini-safe removed, 5 spaces, 19 lbs. with Mini-safe installed (Mini-safe itself has 2-space capacity). Accel. 5, HC 3, 7,181 lbs., \$39,725.

# ADQ&A

Can a turret mounted on the roof of a car, van, or truck successfully target the tires of another vehicle regardless of the 0-45 degree range?

—Eric Cheng  
Palos Verdes Peninsula, CA

*The only current rule that may apply is the one that says a turret on an oversized vehicle may fire over a car that is within a certain range. Certainly, if the turreted weapon can fire over a car in a particular range, it would have difficulty hitting the tires of that same car. To keep it simple, let's try this: For trikes and cars smaller than vans, no penalty; for a van or ten-wheeled vehicle or car trailer, a turreted weapon cannot target a tire within 1/2" of the firing vehicle; for big rigs, no tire within 1" can be targeted. Remember, this is for turreted weapons only.*

—SDH

1) I noticed with your vehicular grenade launcher in *ADQ 1/2*, there could be no mixed loads. In the *Uncle Albert's Catalog*, the "improved" GL holds ten fewer shots than the original. Did you do this on purpose to compensate for being able to mix the loads, or did you simply screw up and do it by accident?

2) My friend and I have a disagreement over the Micro Missile Launcher. I say that only one shot at a time may be fired. He says that you can fire all ten missiles at once, for ten dice of damage (nuke!!). What gives?

3) What effect would a smokescreen or paint cloud have on an RGM or WGM?

4) Do explosions (from bombs, mines, rockets, etc.) produce smoke clouds?

5) Can an anti-theft system be hooked up to Smoke Dischargers instead of AP Grenades? Can they be combined in the same system?

—Alex Lofthouse  
Kitchener, Ontario

1) *We don't "simply screw up" anything . . . we screw it up in a very complicated way.*

*The new, "improved" grenade launcher has only 10 shots for a couple of reasons. One was to balance the change in mixed loads capability . . . the other was that a 20-shot GL was just too powerful. The 10-shot's pretty nasty as it is, and we're looking for ways to make it less so. Stay tuned . . .*

2) *The Micro Missile Launcher is a scaled down version of the Rocket Launcher. And just like the RL, it fires one shot at a time.*

3) *The Radar-Guided Missile System would ignore smoke and paint. The Wire-Guided Missile System treats smoke and paint as any other weapon: -2 per counter.*

4) *No.*

5) *Sure.*

—SDH

1) Could you send me a list of the books you use to get your ideas for your games and scenarios?

2) Can a cluster bomb work on a car? If so, does the car need a launcher?

3) If a limpet mine is placed on a turret, is the turret destroyed? Are the weapons destroyed, too?

—Allen Murray  
Salem, OR

1) *We read lots of different books (and see a fair number of movies), but no particular one is responsible for an idea. They just sort of fall from the sky, like pennies from heaven . . .*

2) *A Cluster Bomb will work fine on a car — blows it up real good. To use one as a weapon, however, requires a helicopter.*

3) *If a limpet mine is placed on a turret, it will do 1d+1 to the top armor. If it's placed directly over the weapon port on the turret, that damage will go directly to the weapon, and any remaining damage will continue to the next interior component, leaving the turret itself undamaged.*

—SDH

1) If you install a fire extinguisher in a tractor, does that extinguisher put out flames in the trailer it's hauling? If not, then can I install a fire extinguisher in both tractor and trailer?

2) Do other accessories (infrared, sound enhancement, stealth mode) have to be bought separately for tractor and trailer? Or can my gunners in a trailer use the infrared in the tractor?



3) Could you please tell me the measurements of all the different vehicles, so I can figure out how many flechette grenades or smoke dischargers I can mount?

4) If I mount stealth mode on any vehicle other than a helicopter, does the vehicle have the same restrictions, even trucks?

—Eric Shoup  
San Jose, CA

1) *One fire extinguisher system will do the job. If the tractor and trailer become separated, however, the fire extinguisher in the tractor will continue to work (it's still connected to the power plant). The part in the trailer will stop working.*

2) *The same goes for other accessory systems like the ones you listed in your question.*

3) *Use the measurement of the counter to determine the size of the vehicle (yes, I know this makes all cars 15 feet long. It's an approximation).*

4) *Stealth mode has the same penalties on acceleration and top speed, no matter the vehicle.*

—SDH

1) Why must a tractor (or ten-wheeler's) front tires match its back ones? I've seen trucks on which they aren't even close!

2) Why does the year 2035 have two Springs (according to ADQ's cover)?

3) I'm sure I missed it somewhere, but can a rocket platform rotate like a turret?

4) If a non-laser weapon is fired through several smoke clouds, is the -2 penalty assessed for each one? What if they are adjacent to each other? What about shooting down the long axis of a HDSS?

5) Wouldn't weapons triggered by bumper trigger gain an extra bonus to hit? After all, their barrels are almost touching their targets!

6) What is the hazard for driving over a prone person?

7) Can an anti-theft system be used to set off a self-destruct explosive?

—Paul Radecki  
South Bend, IN

1) *They don't have to match, but it's a -1 penalty to HC if they don't.*

2) *Choose your favorite answer: A) because we hate summer; B) because we really like spring; C) to see if you were paying attention; D) because we're complete idiots and enjoy*

*getting letters making fun of us; E) because we're human and accidents happen.*

3) *Yes, you did; yes, it can.*

4) *This is a real good question. The current rule states that the penalty is -2 per counter. This is simplest. It also means that firing through a heavy-duty cloud lengthwise (2'' of smoke) has the same penalty as nicking the corner of a regular cloud (less than a ¼'' of smoke). There are three solutions. One, stick with the "-2 per counter" rule because it's easiest to figure out, and put up with the inconsistencies; two, use the "-2 per counter" rule as a guide, but let the referee make individual rulings in obvious cases of unfairness (if you use this method, be prepared for lots of arguments: "That's barely as much as one counter! It should only be -2!" "Bull, you're just saying that so you won't die! Anyone can see it should be -4!" Etc., etc.); three, use the following complicated mathematical formula. Measure the exact number of inches of smoke (or paint, or combination of the two) that must be sighted through, including overlapping counters. (That is, if two counters are on top of each other, they both count.) Then assess a -1 penalty for each ½'' of smoke sighted through, rounding to the nearest ½'' and rounding up if the measurement is exactly between. Less than ¼'' of smoke would still count for a -1. Have fun.*

5) *If you want to put a rule like this in your own campaign, go ahead. But I think the +4 point-blank bonus is plenty of an advantage already. In addition, the projectile that comes out of a weapon could physically strike its target and still not make its "to hit" roll, glancing off or failing to detonate or something like that.*

6) *Treat prone pedestrians like obstacles.*

7) *Effective. Messy, but effective.*

—SDH

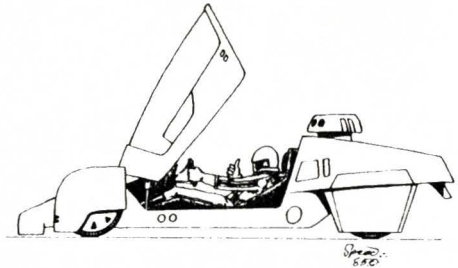



1) Can a Bumper Trigger be designed to fire the linked weapon after the collision has taken its toll, so as to affect any exposed internal components in the target vehicle?

2) Are there any rules concerning getting stuck in mud, sand, snow, etc., while duelling off-road?

—John E. Gerdes  
USS Halsey, Pacific Ocean

1) *That's not the way the Bumper Trigger works. If you assessed collision damage first, the trigger and front weapons may be knocked out before they get to fire.*

2) *No rules yet, but I'm open to suggestion.*  
—SDH

1) In *ADQ 3/1*, it says on page 16, “. . . A typical power plant (fully charged) will last approximately 200 miles if you rarely go faster than 55 mph; . . . subtract 20 miles of range for every 5 mph of speed over 55 . . .” Also, in that issue, was the Thundercat Power Plant, that can go 120 mph. If you calculate the range of a Thundercat in a car going 120 mph, you would get -60 miles for your range. Now don't tell me that a power plant is drained after it gets over 100 mph!

2) Does each single, retractable wheelguard take 1 space for the retracting mechanism, or is it 1 space for all 4 wheelguards?

3) In *ADQ 3/2*, someone asks about ramming a pedestrian with a WGM, and the reply said the WGM was moving at 200 mph.

If that is true, then firing a WGM at a helicopter that is flying away from you at 200 mph is useless. Is this true? If so, how fast are Heavy Rockets and Micro Missiles from a MMR traveling?

4) Can weapons be mounted in or on and fired from a CargoSafe?

—Frank Wong  
Portland, OR

1) *Of course the range isn't -60 miles (talk about an energy crisis!). The best way to calculate range for a Thundercat is to simply add 20 mph to the appropriate rules. Reduce 20 miles of range for every 5 mph over 75 mph.*

2) *One space per wheelguard, four spaces for four.*

3) *That's right, you can't chase down a helicopter at full speed with a WGM (or an RGM, for that matter). The other rockets, however, are treated like all other types of weapon fire: You fire, roll to hit, and assess damage immediately, no matter how far away the target is.*

4) *No.*

—SDH

1) Can you target headlights? If so, can you make them pop-up headlights to protect them when they're not in use?

2) In *ADQ 3/2* you said to Mr. Zisch that the HC subtraction is lifted when wheelguards are destroyed. But you told Mr. Huntsberry that when body and vehicle armor is destroyed, enough of it is still there that there are still penalties. Which is right?

—Derek Riethmeier  
Huntington Woods, MI

1) *No, headlights can't be specifically targeted. Besides, they're fully protected by front armor.*

2) *Sorry about the confusion. Wheelguards, once destroyed, are completely blown away, eliminating the HC penalty. Body armor, on the other hand, still has lots of straps and harnesses and things that continue to slow up the wearer even after the DP of the armor has been eliminated. As for vehicular armor, once the DP has been blown away, the side is not naked — it's just got a lot of holes and gashes in it. If this strikes you as inconsistent, remember the words of Emerson: "Foolish consistency is the hobgoblin of little minds." Or the words of Haring: "It's only a game."*  
—SDH

★ Streamlined Rules!

★ Better Components!

★ More Options and  
Accessories!

★ The Best  
of the  
**CAR  
WARS®**  
World!



ALL RIGHT!  
I FINALLY  
HAVE  
DELUXE  
CAR  
WARS!



I WONDER  
WHAT'S INSIDE..



FAAANTASTIC!

**CAR WARS®** DELUXE EDITION

Coming in June from

**STEVE JACKSON GAMES**

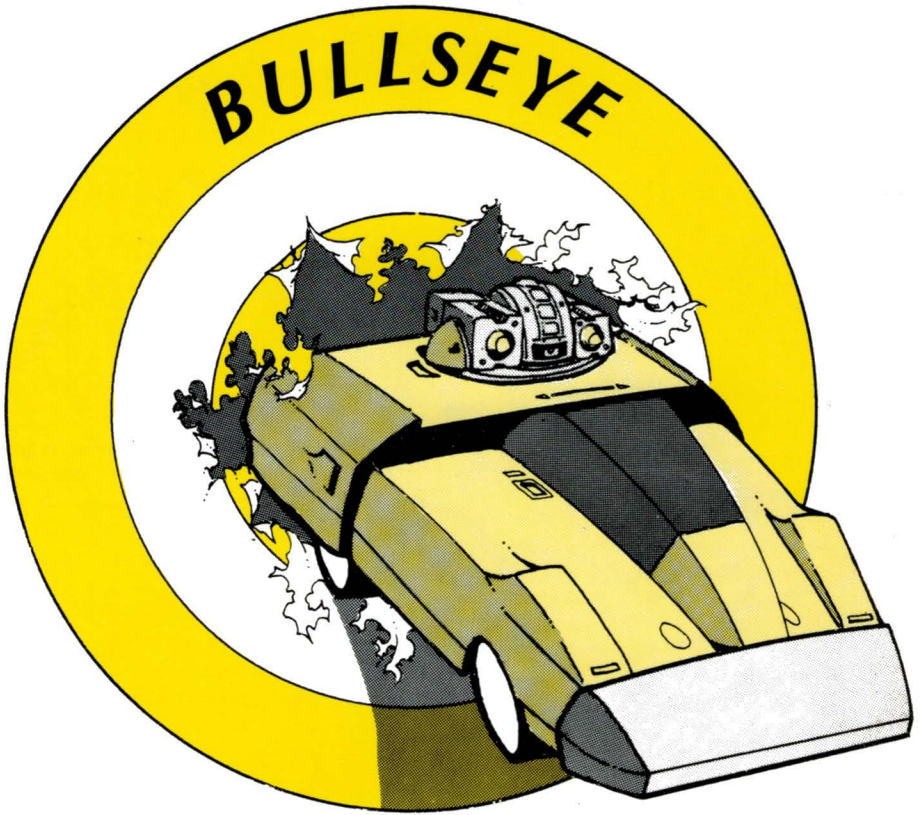

The latest entry from Atlantic Industries is here, and it's a Division 15 beauty that's anything but subtle. During the months of pre-production testing, our engineer's nickname for it was the "Ton O' Bricks" — which is how it will come down on your opponents. Never has so much punch been delivered with this accuracy — and all within Division 15 specifications! The Bullseye is destined to become a standard in the arena and on the highway, just what you've come to expect from Atlantic — the small car leader.

Bullseye — Mid-sized, x-hvy. chassis, hvy. suspension, large power plant, 4 PR tires, driver only. 2 linked HRs in turret, two 2-space HR magazines, targeting laser in turret, laser guidance link. Armor: F40 with ramplate, R40, L40, B50, T20, U20. Accel. 5, HC 3, 5,630 lbs., \$14,970.

Accuracy Option: Add single weapon computer, drop 30 points of armor (from anywhere but front). 5,390 lbs., \$14,980.

Extra Firepower Option: Replace HRs and magazines with RL, drop 40 points of armor (from anywhere but front). Cargo capacity: 4 spaces, 890 lbs. 4,870 lbs., \$14,930. Note: If not concerned with Div. 15 restrictions, additional armor can be added up to the weight limit.

Division 20 option: Replace HRs and magazines with RL, add gunner, RR front, and 2 targeting computers. 5,690 lbs., \$18,620.

# Atlantic Industries

We Aim to Please