

ADVENTURE &1



Publication
&1001

DARE YOU TO ENTER *THE VALLEY OF ETERNAL REST*, WHERE THE TOMBS OF THE ANCIENTS ARE GUARDED BY UNSPEAKABLE MONSTERS AND AN UNBREAKABLE CURSE?

THE VALLEY OF ETERNAL REST

This is the & Publishing Group's first adventure module, a joint venture between readers and the staff of & Magazine

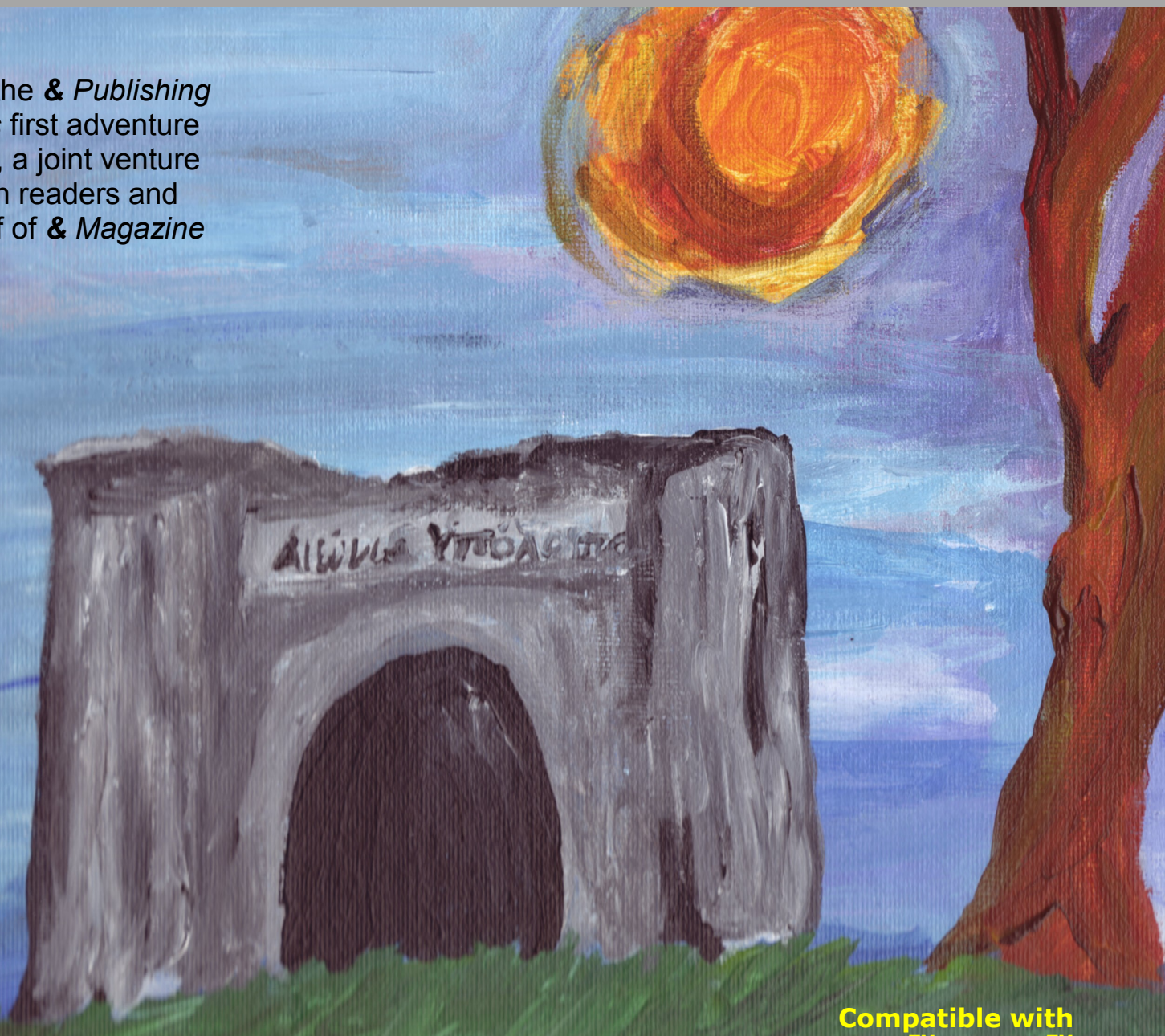

Compatible with
AD&D™/OSRIC™



The Staff

Publisher:

Nicole Massey

Chief Editor/Layout:

Bryan Fazekas

Editors:

Jeremy Dow

Andrew Hamilton

Art Director:

Ralph Glatt

Cartography:

Andreas Claren

Logo Design:

Payton Gauldin

Cover Art:

Caleb Horowitz

Interior Art:

Joe Heirendt

Caleb Horowitz

Contributing Authors:

Patrick Fazekas

Jay Goodenberry

Travis Range

Varl

Featured Artist

This month's cover artist is Caleb Horowitz, a high school student in Raleigh, NC. Caleb has been an artist for most of his life and has been playing AD&D for several years.

Caleb's art graced the cover of & Magazine's inaugural issue, and his interior art is in most of our publications so far.



& Magazine is published four times a year by the & Publishing Group. It is available for download at <http://www.and-mag.com/downloads.html>.

The rights to all material published herein revert to the author(s) of said work upon release of this issue. Articles may be submitted by email to submissions@and-mag.com. Please review the & submission guidelines.

Dungeons & Dragons™, Advanced Dungeons & Dragons™, D&D™ and AD&D™ are owned by Wizards of the Coast

and their use here is not intended as a challenge to their ownership of that copyright. All materials are used here without permission.

All other material copyrighted to the listed author or artist, and used by permission.

Nothing in this publication constitutes official rules additions or changes to the AD&D™ game. Use is at the discretion of the game master and the players of individual games.



Adventure &1

The Valley of Eternal Rest

Featured Artist

Featured Artist 2

Interior Art

Each printed item has the author listed, but not so the artwork.

Andrew Hamilton

Obelisk Shrine 3

Pool Shrine 3

Bryan Fazekas

Chalice of Potions 47

Joe Heirendt

Valley of Eternal Rest 4

Caleb Horowitz

Pyramid and Tomb 7

Monsters

New Monsters 40

Magic Items

New Magic Items 47

The Tombs

Introduction 4

The Shrines 6

Valley Denizens 8

Prelude: Plight of the Thirsty Lamb 9

The Tombs 16

Tomb #1 – The Ancient Warrior 17

Tomb #2 – The Bone Guardian 18

Tomb #3 – Mother of All Worms 20

Tomb #4 – Tomb of the Gnome Prince 23

Tomb #5 – Traps and More Traps 25

Tomb #6: The Pharaoh’s Tomb 26

Tomb #7 – The Forgotten King 28

Tomb #8 – Deathtrap 31

Tomb #9 – Spider Lair 32

Tomb #10 – Bats 33

Tomb #11 – Haunted Treasure Hunt 35

Closing Notes 40

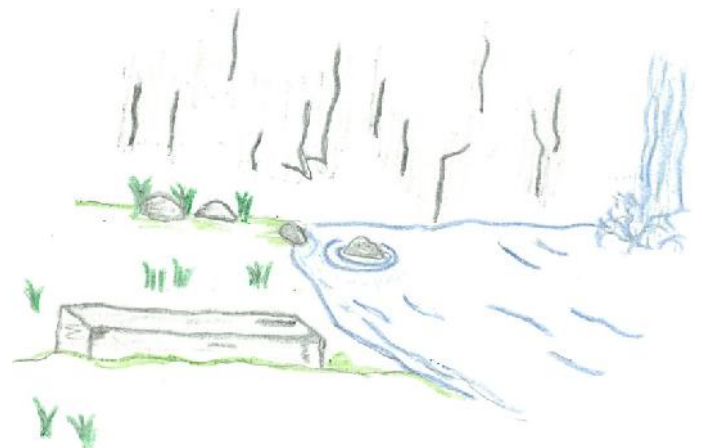

Introduction

This is & Magazine's first effort to develop and publish a co-operative adventure, making the material our readers' material. The expanded version contains material that didn't fit in the version of this adventure originally published in & Magazine, Issue 2. As we compiled this module, we tried to leave the description of each tomb and element in the author's words. While this creates a bit of a "Frankenmodule" with many styles and approaches stitched together, we wanted it to belong to the contributors as well as the readers.

We thank all our readers and contributors, and hope that you find the result interesting, entertaining and useful. As always, your feedback (and continued contribution) is important to us so please let us know what you think.

This generic adventure location is designed to be easily inserted into any campaign, and consists of a number of small tomb complexes located within a valley that has been used as a burial ground for several cultures over several centuries. The location is designed for use with the 1st edition rules, and is intended to challenge a party of 6 or so PCs of levels 4 to 7.

This adventure is designed to be flexible enough to place into an ongoing campaign as a sandbox element, a destination for a quest (as the party seeks a McGuffin or gold), or to break individual tombs out to seed them across their own campaign world. Because the Valley of Eternal Rest has been used by many cultures and races over a long period of time, there is no single architecture, style, or content.



Physical Geography

This narrow valley is located in a foothills region, and has been carved into soft rock (sandstone) by the River of Souls and storm run-off from the plateau above. Tombs have been dug into the cliff faces for centuries, by more than one culture. Others litter the valley floor. The valley is approximately 1.5 miles long, and is about ½ mile wide. There are a few hoodoos, which break up the valley floor. The river descends in falls, with a large pool (a shrine and brier are beside this) then flows out of the valley. The river is about 6' at its deepest, 30' at its widest, averaging 4' deep and 20' wide. It has a rocky bottom and flow is sluggish, moving at one mph. There are suckers and trout in the river.

The cliffs are 200' high, although the bottom quarter to half of the valley walls are actually a steep slope (45 to 70), composed of soil, scree and other material that has eroded from the cliffs and built up along their base. The sandstone faces of the cliffs are

weathered, spalling, and will crumble under a climber's weight (-30% to Climb Wall attempts). They will not hold a piton or spike. The bedrock is laid down horizontally, so there are no chimneys or fractures to aid a climber. The soft rock is easily carved and dug, so deep niches can be created to act as steps, footholds or handholds. Many creatures such as mice, chipmunks, and birds have dug small dens or nests in the cliff faces. Several raptors (including a flock of 11 bloodhawks) also nest on the cliffs.

Bloodhawks (x 11) AC 7, MV 24", HD 1+1, HP 6 each, ATK 3, Dmg d4/d4/d6, SA nil, SD nil, MR Standard, AL N, Size S, Int Animal, XP 32 each (20 xp + 2 xp/hp)

Should someone investigate the nests (a hazardous task as the cliff is unstable and the bloodhawks will aggressively defend their nests) they will find a total of seventeen 10 GPV gems.

Most of the valley is treeless, although willows

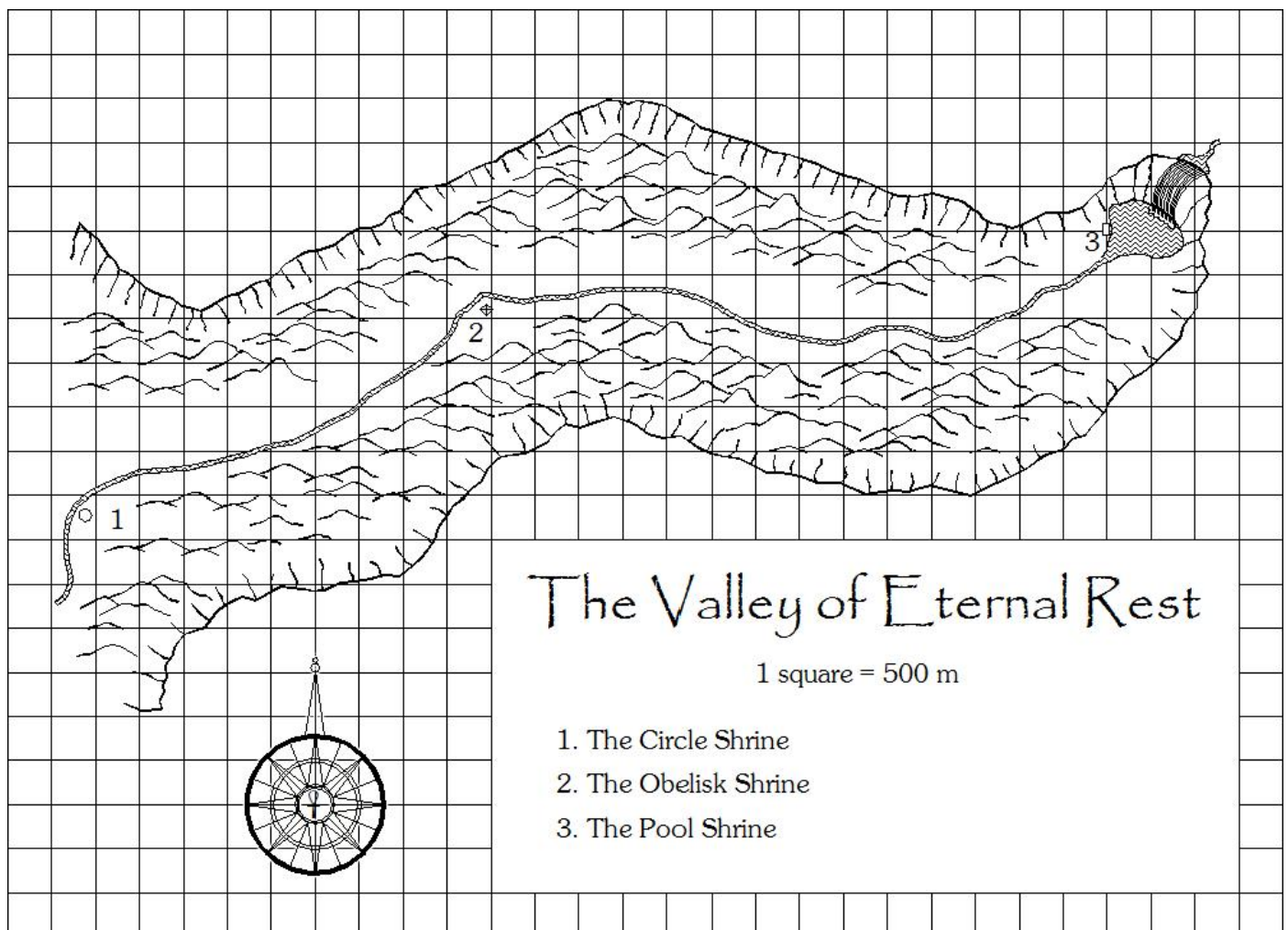

shrubs grow along the river banks, and several small old growth forests hang on. Grasses (tall grass prairie) and wild-flowers blanket the remainder of valley floor, and the slopes at the base of the cliffs.

Valley's Curse and Guardians

A curse protects the entire Valley. The curse does not affect those who come to pay their respect to the deceased, perform funeral and burial rituals, build new tombs, or even pass through, hunting and fishing along the way. However, those who defile a tomb are subject to a -1 penalty to all saving throws for a period of a year and a day. Violators are allowed a saving throw (verse Spells) to avoid the curse, but a saving throw must be made for each and every tomb entered. Repeated defilement results in escalating penalties: For each additional tomb entered there will be an additional -1 penalty and a 49-day increase in the curse duration.

The Valley's curse cannot be removed with a **Remove Curse** spell; this place is sacred to many religions and cultures so the power of the curse is greater than the norm, requiring divine intervention. The curse might (DM's choice) be lifted through a quest sponsored by an appropriate deity.

Each of the three shrines is also protected by a unique curse (as described below).

A residual ward of a long forgotten God of the Dead, there is a band of 8 Guardians of the Dead. The Guardians appear as simple skeletons, wearing battered and tarnished bronze armor (including bronze helms and shields), and wield short swords.

The Guardians cannot be turned, and if destroyed, the power of the God of the Dead causes them to reform each night. These creatures pursue tomb robbers out of the Valley, following them relentlessly. The Guardians must be destroyed 9 times to finally defeat pursuit.

The Guardians of the Dead are not evil, and their charge is to protect the remains of those who have been interred in this location, and to revenge them when necessary. If a party is camping in the Valley but has not defiled any tombs, they may see the Guardians patrolling. However the Guardians will not approach simple travelers, those visiting to pay homage to the dead or worship at a shrine, or prepare a new burial niche or tomb. Should the party defile a tomb, the Guardians will attack, fighting intelligently and without fear or quarter.

Guardians of the Dead (x 8) (AC 2, MV 18", HD 3+3, HP 27 each, ATT 2, DMG 1d6+1 per attack, SA +3 to initiative; strike as 6 HD creature; able to harm any creature, SD immune to turning, sleep, charm, cold, poison of fear; ½ damage from slashing/piercing weapons; regenerate 1 hp/round, MR standard, INT Average, AL N, XPV 318 each)

Turning Undead

Undead may be turned, but not dispelled or disrupted. This is the final resting place of the individuals buried here, they were buried with ceremonies and rituals, so the souls of the undead are strongly anchored here. All turning attempts are made at an effective level 2 lower than the cleric, and any D results are instead treated as a T.

The Shrines

Three shrines dot the floor of the Valley, each dedicated to a different death-oriented deity. The specifics are up to the DM, but at least one should represent a forgotten deity.

Pool Shrine. As already noted, one shrine is located next to the pool at the base of the waterfall, beside a

large funeral brier. One culture who uses (used?) this valley burned their dead and scattered the ashes into the pool, allowing the River of Souls to carry the last of the physical remains on their final journey.



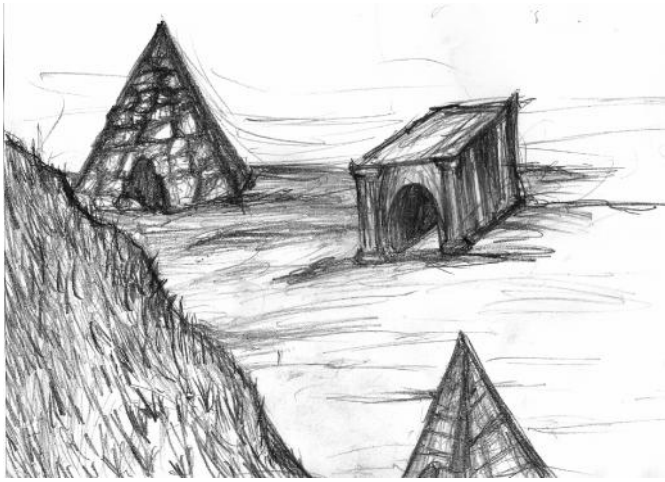

The pool has items thrown in it (including coins, jewelry and other treasure, DM's choice) but is protected by spirits (4 spirits, each equal to a Water Weird of maximum hit points) and a curse. Those who defile the shrine or the pool will suffer nightmares for 13 days, and during that time they will be unable to sleep or rest (suffering a -2 penalty to initiative and surprise rolls, and spell casters will be unable to regain spells). Furthermore, the victim of the curse will automatically fail all saving throws vs. fear until the curse is removed, requiring a cleric or magic-user of 14th level or greater. Note this curse is powerful enough to defeat the cavalier's immunity to fear effects.

Water Spirits(4): AC 4; HD 3+3; HP 16 each; MV 12"; AT: 0; form in two rounds from water to strike as six HD monster; target must save vs. paralyzation or be dragged into the water, drown in a number of segments equal to the victim's Constitution score (see page 100 of the *Monster Manual*); Int Ave; AL N; can be temporarily turned as a six HD undead. Note: these water animated by an undead spirit, not elementals. XP 434 each.

Obelisk Shrine. This shrine is a short obelisk, cylindrical, carved from grey granite standing 9' high and approximately 6' in diameter, the base is sunk 4' into the earth. The obelisk is decorated with carved glyphs and images, although these are weathered and barely readable. The glyphs and images praise a deity of death and rebirth, and they call upon that deity to escort the souls of the deceased to the afterlife and protect the sanctity of their tombs. The Obelisk is a remnant of the original

people who used this valley as a burial ground, and it is holy to a god no longer worshipped by the residents of this region.

Anyone attempting to damage or deface this shrine will be subject to an **Energy Drain** attack as per the 9th level MU spell. Repeated attempts to damage the obelisk will result in repeated Energy Drains and the appearance of the Guardians of the Dead. Anyone who is drained to fewer than 0 levels will immediately rise as a juju zombie and defend the obelisk.

DM's Note: the obelisk might stand atop the entry to a buried shrine and tomb complex, sacred to this forgotten deity. Of course, surviving the energy drain curse and the Guardians of the Dead and actually moving the obelisk to gain entry to such a tomb will be a challenge.

Circle Shrine. This shrine is a low stone "table", 8' long, 5' wide, and 3' high. It is known as the Circle Shrine because wooden and stone benches are placed in a circle around it, providing seating for those who attend funeral services. The deceased are laid upon it, and last rites are read over them, those attending the funeral pay their last respects, and the body is cremated or carried to a grave or tomb. Signs of past funerals can be seen in fire damage, including some piles of ashes.

Located close to the mouth of the Valley of Eternal Rest, and it is actively used by worshippers of a local pantheon. Some refer to this as the Garden Shrine, as some worshippers have planted flowers and flowering shrubs around it, and they tend these flowers during the spring and summer.

The Circle Shrine is protected by the curse of slow healing. Anyone who defiles the shrine, including bringing violence to those who would use it for its intended purpose, is subject to a powerful curse (remember that this location is sacred to an entire pantheon). For a period of nine full moons (one full moon per deity in the pantheon) the PC will receive minimum benefit from any curative magic, and no benefit from any curative spells cast by a deity of this pantheon. Should clerics of this pantheon defile the shrine, they will immediately be stripped of their spell casting abilities until they perform



atonement and return to the good graces of their deity.

Valley Denizens

In addition to the Guardians of the Dead, each tomb may have its own occupants (see below for details), but there are few creatures or entities that make the Valley home. Oddly, there is some small wildlife (rabbits, mice, moles, and coyotes that hunt them), and they do not seem to be bothered by the undead. In fact most of the undead rest peacefully until their tombs or the sanctity of the Valley is disturbed.

Daytime Wandering Monsters

There is a 1 in 10 chance for an encounter, roll every 12 hours.

d100	Monster
01-20	Small game, such as rabbit, grouse, or a similar critter.
21-30	Raptor. 60% lone hawk or eagle, 40% Bloodhawks.
31-50	Large game such as deer, antelope, elk or other creature appropriate to the campaign, likely just passing through
51-60	Tomb robbers (See <i>Monster Manual</i> , p. 66, <i>Bandits</i> , adjust difficulty for party strength). They will be cautious, expect trouble, and will defend themselves violently.
61-75	Worshippers (50% burial party, 25% relative paying respects, 25% clergy)
76-85	Hunters (50% human, 50% gnoll, bugbear or orc). This group is passing through and not looking for trouble, although they'll put up a fighting withdrawal if necessary – and return with reinforcements.
86-99	Spooky but non-violent event, e.g., PC feels fingers on their spine, a voice drifts across the Valley echoing and calling out one of the PC's name, wine turns to vinegar, food spoils or tastes like ashes, horse bolts, etc.
00	DM's choice, e.g., insane necromancer seeking to raise an army of the dead, sage interested in the history of this place, divine manifestation, dragon aloft, etc.

Night-Time Wandering Monsters

There is a 1 in 10 chance for an encounter, roll every 12 hours.

d100	Monster
01-10	Small game (mouse, rabbits, coyote)
11-20	Flying hunters (30% owl or 70% bats)
21-40	Guardians of the Dead (see below)
41-50	Tomb Robber (see daytime description)
51-65	Ghoul pack (2d12 ghouls). These prowl the valley looking for live prey, and will attack immediately.
66-75	Giant Bat/Doombat (80%/20%)
76-85	Wailing, weeping, or other cries (1 in 4 or at DM's discretion). This may be a set-up for an ambush by leucrotta, intelligent undead or tomb robbers, etc., or it may be an unexplained haunting.
86-99	Spooky but non-violent occurrence, e.g. camp fires die or flare up, or changes to green flames, PC feels fingers on their spine, wine turns to vinegar, food spoils or tastes like ashes, horse bolts, etc.)
00	DM's choice, e.g., a ghost appears and converses with the characters, divine manifestation, necromancer and undead minions, etc.



Prelude: Plight of the Thirsty Lamb

by Travis Range

Background Information

The inn known as The Thirsty Lamb has a reputation of fine service and fare. It is several miles away (about a day's travel by cart or wagon) from a town on a minor trade route. The remote location of the inn makes it an ideal resting place for travelers. The inn keeper is known to be on good terms with his neighbors and has often gone out of his way to help some of the local farmers. It has been noticed by the party that trade passing through the area is lighter than normal for this time of year.

The road the inn is situated on travels east and west. It is located roughly a quarter mile north of the road. To the east is a bridge over a deep creek that must be crossed (*unknown to the party, there is a suitable ford that is located north in the tree line that will be used by cultists later*). To the west are a series of

hills that are possibly foothills to a mountain chain that begins to loom in the distance some 20 miles off. The road here is a dirt affair that shows the ruts of passing wagons through the many years. There are mile markers to the town that begin at the bridge but there are no further milestones west of here through the mountains.

The panorama is one of beauty and game is plentiful in the woods here.

DM's Information

A pair of rutterkin demons has taken over this remote inn. They have slain some of the occupants and lure unwary travelers to their demise. Their intention is to build an army of undead beings with which to terrorize the countryside and eventually to begin transformation of this world. How they arrived in the Prime Material Plane in the first place

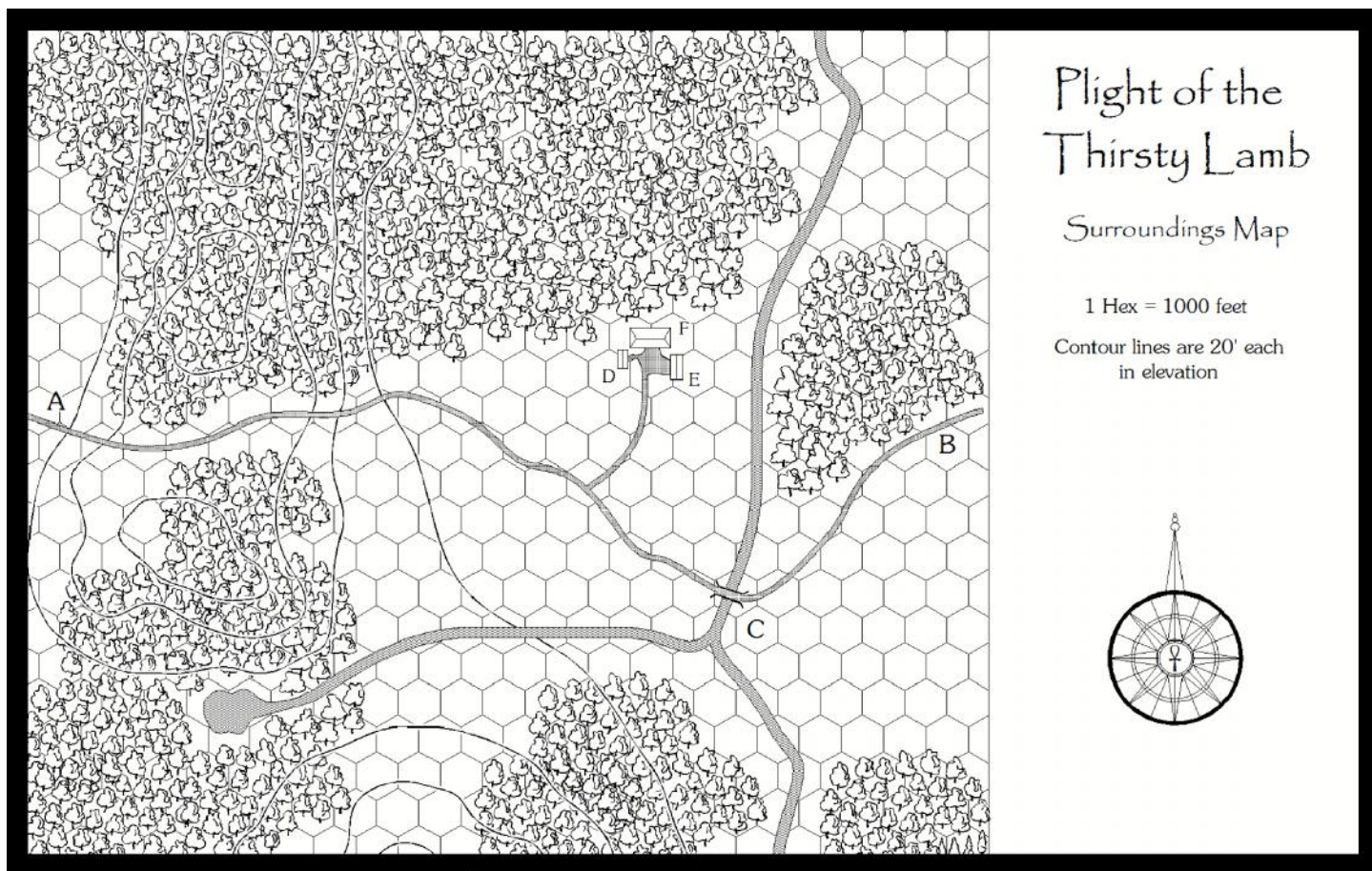

is left to DM's discretion. They currently reside in basement in an extra planar space that is a "gift" of their demon lord. They first attracted the service of a ghoul (who was lost in combat later) who was able to slay and transform three members of the inn staff into ghouls. The demons also managed to charm the remaining three and have used them to help maintain the guise of the Inn. Through the last several months, the little pack of evil has managed to slay several small caravans and convert the dead to zombies. The demons intend to convert three more zombies (no rhyme or reason to why three) then allow the ghouls to grow their numbers.

Monaxis and Malivax (Rutterkin demons): AC 1, MV 12", HD 5+1, HP 28, 22, # Att 1 or 2, D/A BW or 1d6+1/1d6+1, SA Darkness 5' radius, Fear (touch), fly, telekinesis (1000gp wt), teleport once per day, gate chasme (15%). Monaxis (22 hp) uses the snap tongs and (d2-8 then damage every round until break free, and Malivax (28 hp) uses the double crescent polearm (1d10/1d12)

Monaxis 557 xp, Malivax 593 xp

Ghouls (AC: 6, MV: 9", HD: 2, NA: 3, D: 1d3/1d3/1d6, SA: Paralyzation, SD: immune to sleep and charm, AL: CE) who serve the demons posing as cook, maid and stable boy. EXP: 65 + 2 xp/hp

Zombies (AC: 8, MV: 6", HD: 2, NA: 1, D: 1-8, SA: None, SD: Immune Sleep, Charm, Poison, AL: N); EXP: 28 + 2/hp

Has several slaves for food (3 members of former inn staff, charmed). Bartender, Barmaid and Hostler (AC: 10, MV: 12", HD: ½, HP 3 each, NA: 1, D: BW, SA: None, SD: None, AL: LN)

Stirges (AC: 8, MV: 3"/18", HD: 1+1, NA: 1, D: 1d3, SA: Drain blood, SD: None, AL: N); EXP: 36 + 2/hp

Story and Areas

A: Approach from the West

The party is on the road east. They camp out for the night as they are unaware of how close the Inn actually is (about 2 miles down the road). Sometime after dark, the party is beset by three ghouls. Before

ghouls are slain they run down the road. If the party gives chase, they see the inn. It looks lively and the ghouls are heading for the barn.

Good aligned PC's should deduce that the ghouls are there to kill and eat some innocent passerby (already done at this point..... several times over.) It should be noted that it is not the ghoul's intent to kill any party members but rather to get them to give chase. They will try to paralyze one or two of the party and then run off through the woods.

B: Approach from the East

In the woods north of the road across the creek from the inn the party sees firelight. As they approach, they find several cultists engaging in the sacrifice of some young victim.

If the PC's rush in to save the victim, they find out it is a lamb, tied up and dressed to resemble a young child. The poor creature was to be sacrificed, that is for sure. The cultists run off into the night (back to the inn under cover of darkness).

If PCs don't interfere, then the cultists will head to take places in the common room once the sacrifice is held, they have noticed the party passing in the dark at this point. In any event any of these fellows who survive will be encountered later.

Zoulhar Moramen: 3rd level cleric (AC: 4, MV: 9", HP: 14, Str: 14, Int: 12, Wis: 15, Dex: 12, Con: 14, Char: 11, NA: 1, D: 1d6+1 or 1d6, AL: CE). Armed with chain mail and large shield, wields a mace and club carries 30 sp, 15 ep, 4 gp in a purse carried around his neck. In a false heel in his boot, he carries a bloodstone (350 gp)

Spells in memory: Darkness, Cure Light Wounds, Sanctuary, Curse, Hold Person, Silence 15' Radius.

(5) Cultists (3-24 cp ea.) (Scimitar, dagger, leather armor and small wooden shield) (MV: 12", AC: 7, HD: 1d6 hp, HP: 6, 5, 3, 3, 3, NA: 1, D: BW, AL: CE)

C: The Bridge

This Bridge connects the Inn to the town as this is the best place to ford the broad creek that runs between the town and the Inn. The bridge is not



currently occupied but the party will notice a foul stench of something decaying as they cross.

If the party searches the creek, they will find the carcass of a horse and the body of a man. The horse and the man both show signs of combat and are covered in claw marks (the work of the ghouls). If the man is left more than one day he will rise as a ghoul (AC: 6, MV: 9", HD: 2, HP: 9, NA: 3, D: 1d3/1d3/1d6, SA: Paralyzation, SD: immune to sleep and charm, AL: CE) the following night and join the group at the inn. The horse will not rise from dead but possibly could be animated if the party so desires or the Demons somehow get that far. (A rutterkin mounted on an undead horse?????)

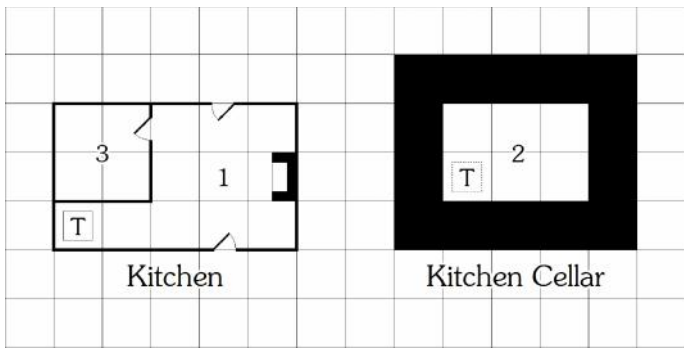

D: The Kitchen

Kitchen: This area is typical of where food is prepared at any other Inn or tavern. There are various counters, cabinets, a bread rack, and other instruments. What are out of place are the charnel smell and the disarray of this area. As one of the ghouls (AC: 6, MV: 9", HD: 2, HP: 11, NA: 3, D: 1d3/1d3/1d6, SA: Paralyzation, SD: immune to sleep and charm, AL: CE) was at one time the cook in the inn, it tries to continue to perform the act in order to lure prey into the Inn.

The conversion from life to un-death has destroyed any real skill the creature had and it's chaotic mind cannot grasp the idea of straightening the place. Pots and pans have been left where ever they were last used; vegetables are out and cut, but very poorly and without regard to any sort of order. If the PC's have ordered food then the ghoul will be here. If not then he will be moving around the back of the inn to the scullery. If encountered and combat

has not yet occurred, he will be in disguise and try to avoid contact muttering about "work to do. Time to prepare....."

Root Cellar: This is where the ghouls do their macabre feasting. They seem to think it is funny joke to feast where once they stored sustenance. In addition to the hanging herbs and sacks of potatoes and onions stored here there are several (3) extra casks of wine (80# weight ea. Worth 30gp ea.)

The place is a mess of filth and gore from prior ghoulish meals and smells so bad that characters must make a save vs. poison or become nauseated. While here all characters nauseated fight at -1 to hit and damage (as if STR: 7).

Discarded within the carrion in this room are several pouches (5) that contain random small coinage (D6 copper and silver) there is one item of value tossed idly into a sack of potatoes. It is a silver ring set with turquoise worth 35 gp.

If the cook discovers adventurers snooping around down here, he will throw the trap door and pin it with a stout rolling pin. It will take several rounds of hacking at the stout cellar trap door to get through it. It should also be noted that the weapon used will also need to make appropriate saving throws if not designed for chopping or smashing wood. He will then run to the Inn to get help. If he succeeds, the whole gang will be there except the barn zombies who will show up three rounds later.

Storage Area: This area is the storage area for hung meats and cheeses. Hanging in the room are also the carcasses of a cow and a goat as well as one of the former guests of the Inn, dressed as the other carcasses. The ghouls find great sport in trying to feed travelers former guests of the Inn. This particular victim was killed by the zombies therefore will not become a ghoul.

The ghouls also store their treasure here. In a small sack under a counter (the ghouls think it is particularly well hidden there but it is out in reasonably plain view.) are 273 cp, 125 sp, 14 gp, and a small piece of jade (20 gp base value). They also have a scroll of 1 magic-user spell (the exact spell to be determined by the DM) in a bone scroll



case that is inlaid with silver and stoppered with carved ivory stoppers (125 gp).

E: The Barn

Stables: This area is quiet. The ghouls will pass through here to grab their costumes and instruct the 5 zombies that are here. The zombies lie under the straw that sits in piles around the barn. Due to the straw and normal smell of the barn, the stench of decay is not readily noticeable. Horses and pack animals will be nervous but will not bolt or run. They will tend to remain grouped together if left here.

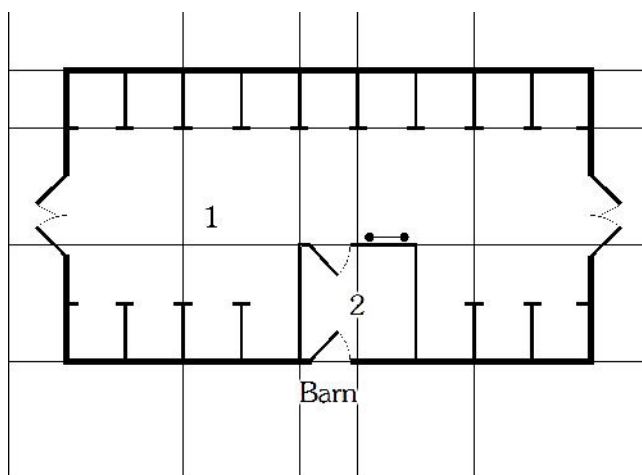

The zombies will rise to attack 6 rounds after the party arrives if they do not leave or begin snooping. If the party stables their mounts and leaves, the zombies will take the mounts out unbridle them and set them free. The zombies statistics are:(AC: 8, MV: 6", HD: 2, HP: 13, 10, 9, 6, 5, NA: 1, D: 1-8, SA: None, SD: Immune Sleep, Charm, Poison ,AL: N)

Barn Storage: This area shows signs of recent activity. The doors are slightly ajar and there many (10) cloaks lay upon a table (disguises taken from former guests). It is otherwise filled with the normal barn implements that are tossed about haphazardly.

Hay Loft: This area is typical of any hayloft but has been disused for quite some time. It has about half the hay in storage that it would at this time of year. As it has been unused it has attracted the attention of a pack of stirges (AC: 8, MV: 3"/18", HD: 1+1, HP: 8, 7, 4, 4, 3, 2, 2, NA: 1, D: 1d3, SA: Drain blood, SD: None, AL: N) who have set up their nest in this

area. They have built their nest in the rafters of the loft. It is a large affair made of straw and sticks they have brought in from the woods. In their depredations they have collected four gems (base 50 gp) and a silver necklace set with garnets (base 400 gp) that they have deposited in their nest.

F: The Inn of the Thirsty Lamb

Main Floor

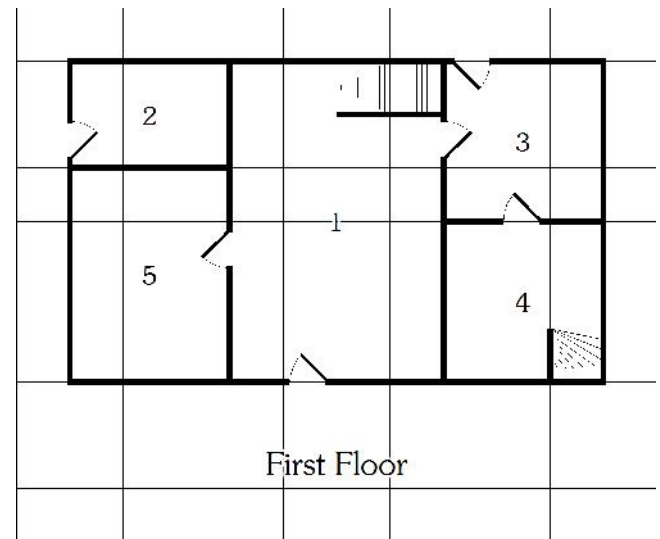

The Common Room: When the party arrives at the inn, they will notice three people in cloaks drinking quietly at the table in the corner (3 zombies (AC: 8, MV: 6", HD: 2, HP: 9, 9, 2, NA: 1, D: 1-8, SA: None, SD: Immune Sleep, Charm, Poison ,AL: N)) the barmaid, bar tender and hostler all speak jovially with the six other men in the bar (Cultists and priest) posing as passing mercenaries and a travelling priest of Hamar. They are drinking, but not eating.

The ale and beer are very good which should at least be somewhat conciliatory for the miserable food served here. Occasionally the cook (Ghoul, 11HP) will be heard bringing trays over from the kitchen (beware the foul!) and the stable boy (Ghoul, 4HP) can be seen in the night tending to the mounts (tending them all the way to the woods). The Maid, who is a ghoul (AC: 6, MV: 9", HD: 2, HP: 8, NA: 3, D: 1d3/1d3/1d6, SA: Paralyzation, SD: immune to sleep and charm, AL: CE), will be heard shuffling around preparing rooms.



If the party actually gets to go to bed (not spooked or tipped off to the sinister plots unfolding) they will each be offered a room for the reasonable price of 2 SP (business has been slow lately).

When the characters get to bed, in whatever arrangements they have, one of their number determined by class (strongest fighter, cleric, mage, thief in that order) will be kidnapped (or at least attempted). The high priest will cast hold person on the victim (one victim saves vs. spell at -2) and then Silence 15' rds on one of the cultists accompanying him. They will then bind and gag the victim and take that worthy to the common room in order to make sacrifice to the new lords (the rutterkin).

The demon Monaxis will make his entrance from the basement in order to enjoy the sights and sounds of sacrifice. The three zombies will have been sent below to await further instructions along with the largest ghoul (preparing the chambers below to make another zombie). Within the room will be the 5 cultists, the priest, and Monaxis. Monaxis and the priest will fight until they reach 1/3 of their hit points and then retreat to the cellars below. The two ghouls will have been sent to the barn to gather the other zombies in order to attack the party sleeping upstairs after the grisly sacrifice. The charmed bartender barmaid and hostler will stare blankly on but will not take part in any fighting. If they survive these ordeals they will be haunted for the rest of their lives by the images they have witnessed.

Mud Room/ Serving Area: This area serves as the back entryway to the inn. It is typically used for bringing in firewood, and when food has been prepared. There is a fireplace in the north wall that has a swing out hook for hanging kettles for tea or stewpots etc. The south wall has a counter which holds extra place settings and mugs and also has a small prep area for minor items as well as a bread rack. This area is also well kept by the hostler and so is reasonably neat and tidy.

Some items of interest in this room are small knives kept in a drawer in the counter. In the back of the drawer behind a long forgotten false back in the drawer pocket is a small box containing 20PP and a small gem (50gp base). There is also a rolled up map

that will radiate dim magic if detected for. It records the entrance to the valley of the dead. It has been protected with a secret page spell. The command word for the secret page is "burgundy". It otherwise appears as a letter of indebtedness to the hostler from one Edgiard Morelsnout (who is this enigmatic character?). Other than that there is little else of interest in this room.

Back Room/ Scullery: This area is where the dirty dishes and mugs are brought. There is a large basin where water is kept for the purpose. In addition to the normal uses of a scullery (where slop is also collected to feed to the pigs) this area has a table and chairs where staff are fed. It is also used as a meeting place, break room, living space, extra kitchen prep space. If not attending to horses, the small stable boy ghoul (AC: 6, MV: 9", HD: 2, HP: 4, NA: 3, D: 1d3/1d3/1d6, SA: Paralyzation, SD: immune to sleep and charm, AL: CE) will be here unless called to other places.

Storage Room: This room serves as a coat room and also where the hostler keeps a rack of his most popular wines and liquors as well as a cask of his house ale. There are cloak pegs on the western wall and in the southeast corner is a set of spiral stairs leading down into the cellar. Aside from some extra beer mugs and crockery stacked neatly on a shelf that runs along the south wall, there is nothing else of interest here.

Private Dining Hall: This room is a private room for those who require privacy or special treatment. Passing nobles will use this room to take their meals or meet with each other particularly when secrecy must be kept. It is also used by merchants who would like to put on the trappings of nobility.

The floor is covered by a thick rug and there is a fireplace in the west wall complete with poker set and holder full of split wood beside it. In the center of the room is a well-made table and six high backed chairs. There is a buffet table under the window in the middle of the south wall with a crystal wine and goblet set sitting upon it. There is a small corner curio cabinet in the northwest corner of the room upon which sit some interesting items (a very clear crystal, a small rodent skull perfectly intact, several painted blown duck eggs, a small



collection of sea shells, and large set of boar tusks. On the table in the center of the room are two small silver candelabra (20gp ea) and six serving sets of silver (10gp ea.). The room is currently unoccupied.

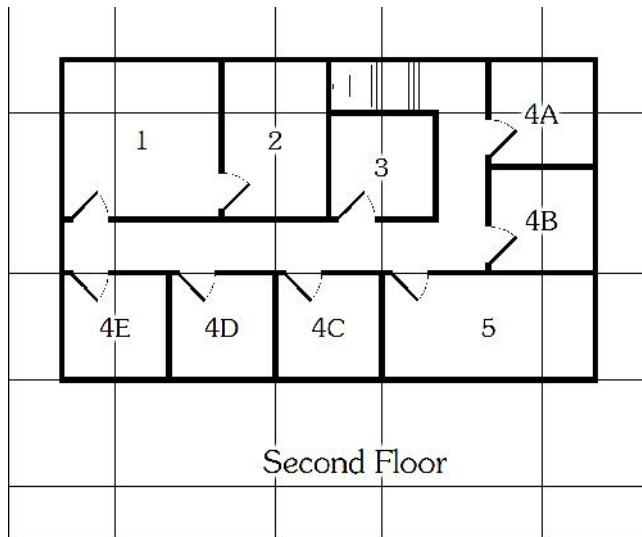

Upstairs

Hostler's Den: This sitting room has a couch and several comfortable chairs. A table with a silver wine service (50gp) set on it and 4 crystal goblets (10gp ea.) sits between two of the chairs arranged in front of a fireplace in the northwest corner of the room. There is a set of fireplace tools by the fireplace and a small stack of split wood sits nearby. The couches sit in northeast corner divided by end tables and a coffee table joins the sitting area here. On the coffee table sits a chess set made of bone and wood. It is well carved and the board is made of two different kinds of marble inlaid into a polished wooden base (20gp)

Hostler's Bedroom: This is the bedroom of the hostler and is neat and tidy. There is a shelf along the east wall of this room and a fireplace in the northeast corner. The shelf holds a collection of books covering various subjects such as wild mushroom identification and habits of various local fish species some are intended for beginning readers. There are ten books in all each worth about 10gp each.

Child's Bedroom: This bedroom was once the sleeping quarters of the hostler's son (now the smallest ghoul). It has a disheveled bed and a chest

that lays open that looks as if at one time it held clothing and the things that a 9 year old boy would find valuable. There is a shelf on the east wall that holds more items but does hold one item of value. A small brass clockwork cat and mouse toy worth 50gp.

Guest Bedroom

These bedrooms are laid out similarly. Each has a dresser a chest and a bed, as well as a stand that holds a chamber pot and other sundries in keeping with any typical Inn. Due to his charm, the Hostler himself takes care of these rooms so there should seem nothing amiss and indeed these are very comfortable quarters.

A. This room has a very comfortable bed that is neatly made with a down comforter and goose feather pillows, obviously attained at great expense. A small footlocker sits open at the foot of the bed. There are two high backed chairs that seat facing a fireplace on the outside wall of the room with a small ottoman in front of each and a small table divides the pair. Fire service sits on the right hand side of the fireplace and a small pile of split firewood next to that. A dresser and a short set of shelves with a chamber pot complete the room.

B. This room is identical to A. above

C. This room is identical to A. above except the mattress is not goose down but is straw instead. The pillows are still goose down.

D. This room is identical to C. above

E. This room is identical to D. above

Sitting Room/ Lounge: This room has several high backed plush red velvet chairs and a shelf with several books and other curios set upon it. There is a fireplace in the middle of the eastern wall. Two windows face out of the south wall that commands a view of the road from here.

There are several bookshelves spaced out in the room and six chairs make three "sitting" areas where guests can read or discuss what they may. There is a chess set that has a board made of bone and walnut squares with pieces made of similar



materials that lays upon one of the three tables that divides each chair. Several oil lamps are placed strategically to allow reading light even in the dead of night.

Along the west stands a small serving station with a bottle of brandy and a bottle of wine ready for the evening's events. If someone in the party scrutinizes the bottles, they will notice a layer of dust covers both bottles. This room is currently unoccupied.

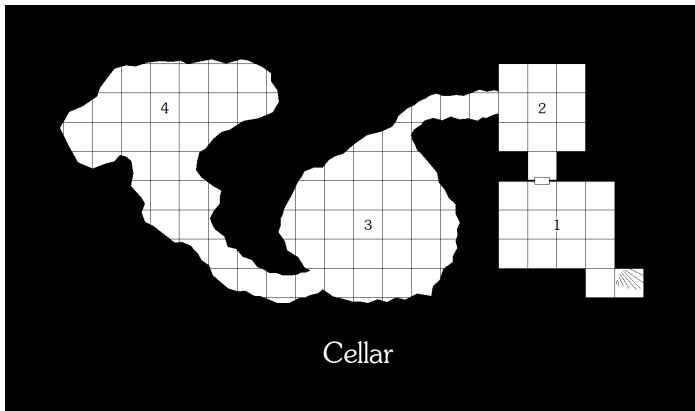

Cellar

Wine Cellar Chamber: This area looks to be like any cellar in any inn. It is as finished as it needs to be so the walls are creek stone foundations for the inn above. There are several large support beams and a line of support pillars that run east to west down the center of the room. It so happens that there is no less than 144 bottles of wine stored in this chamber as well as a tun cask (house wine). They are the Inn's stock in trade and require some space. There is a passageway heading north from this room. The demons have not disturbed this room as they consider the wine to be bait for more humans.

Ale Cellar Chamber: This room is the ale cellar of the inn. It is much the same as any ale cellar in any other inn. The ale here is of several varieties and one of each variety has been bunged. The hostler keeps 16 hogsheads of beer, 6 hogsheads of ale, 5 of mead and there are 15 barrels of other brews including two very fine dwarven varieties (150 gpv ea. 250lbs apiece). As is the case with the wine racks, the demons also consider this room to be their bait supply.

Lair Chamber 1: This chamber serves as an abyssal temple to the powers of chaos. As the players enter

they will feel a slight disorientation when they cross through the barrier where the wall of the beer cellar once was. This is due to the fact that they have entered a small demiplane (a gift from one of the demon princes to their enterprising rutterkin servants). The room is filled with the bones of many animals and a few human skeletons (the remains of former feasts).

The demons also have had an altar constructed that bears leather (made of human hide) manacles and the stains of recent use. It is used for many reasons but with the proper rituals can be used to animate dead, creating zombies and skeletons. The rutterkin plan to leave the charmed slaves they have to the ghouls when the current supply of "bait" is exhausted and the inn is no longer useful.

Lair Chamber 2: This chamber is the lair of the demons and has two pallets made of bones that the demons (who do not sleep) can rest upon as they plan and plot their evil schemes. There are three closed chests that sit in the middle of the room. There are also piles of skulls in various stages of decay that lie haphazardly across the room. Malivax lairs here. Being slightly stronger than Monaxis, he rarely emerges except to occasionally feed or take part in the mayhem and destruction the underlings might wreak. As rutterkin do not possess the ability to animate the dead innately, they must perform the act through combined rituals with the cultists and ghouls. As they build their "army" they are aware that at some point they must abandon this lair in favor of a new one. They are waiting for the cultist priest to become powerful enough to animate dead on his own then they will move on.

In this final encounter, if the battle is going poorly, the demons will use their teleport ability to save themselves and if possible, the priest. If either demon escapes, they will bear a significant grudge toward the PCs, and the demons will be a recurring enemy.

The demons keep their treasure stored here in three chests. So far they have claimed many coins from their victims (2000 sp, 100ep, 110gp, 2 gems (250GP Base)) which they keep in one chest. The second chest contains what appears to be some sort of reptile eggs. Upon inspection the egg appears



translucent with sickly green and black veins that continually move through the “egg”. These are the physical manifestations of souls the demons have collected that will be turned into larva upon their return to the abyss. There are ten of these objects laid in the chest. If or when the eggs are taken out of this minor demi-plane and back to the Prime Material plane they will evaporate as the souls have been released to travel to the pits of hell where they belong. The third chest is left to DM’s Fiat and can contain as little or as much as the DM sees fit. This mini adventure is light on treasure so a party that has performed particularly well might receive some minor magic items. A severely damaged party might find some healing potions or whatever. A party that has played poorly might find nothing in the chest and less in the others.

If both demons are destroyed the party will find themselves in a hurry, as these chambers and the

emi-plane begin to collapse. This process takes three rounds to begin with a low rumbling, three rounds (rounds 4 to 6) later the walls begin to shift and slowly breathe as they begin to compact at a steady rate. Three rounds later (rounds 7 to 9) the magic that holds this plane into existence fails completely, the floors begin to buckle and roll. A round later (the 10th round) the planes completely collapse, any characters remaining within are lost to the Abyss.

This process will also occur if the demons leave the immediate vicinity of the inn (3 mile radius) which, if they teleport away, will occur ten rounds after they leave. In any event, once the party crosses into the beer cellar they are safe. IF the party gets this far, the charms on the remaining slaves will be broken, the party is still not out of danger yet as any remaining cultists, zombies, and ghouls will seek to destroy them as they emerge from the cellar and will have prepared for the PC’s emergence.

The Tombs

There are literally scores of tombs dug into the cliff faces and valley floor. They range from simple graves (a hole in the ground) to multi-room tombs with physical and magical traps and protections, and everything in between.

Many tombs have been despoiled, but many others are untouched and unvisited for decades, even centuries. The number of despoiled tombs would be higher except for the curse upon the Valley and the guardians who slay violators (see page 6).

Over 1,000 graves have been dug, but not everything interred here is human or even demi-human. The DM is encouraged to incorporate tombs of their own design in the Valley.

DM’s Note: The three shrines are placed in the Valley, see the map on page 5. The tombs that follow are not. Each DM should place the tombs they are using in whatever place and order they see fit.

The tombs are described in the following sections.

Tomb #1 – The Ancient Warrior

by Andrew Hamilton



A warrior-chief was interred in this tomb by his clan after he died in battle, defending their ancestral lands.

The entrance to this tomb is a secret door, hidden by loose sandstone at the back of a cave (currently unoccupied) and trapped with a deadfall trap (-15% to find and remove traps, as the mechanisms are on the inside of the door). The trap causes suspended rocks on either side of the door to fall, causing 2d6+2 hp of damage to those in a 7' radius around the door (save vs paralyzation for no damage).

The first room of the tomb is a long narrow hallway, along which 12 armored skeletons slump in alcoves. The skeletons animate and attack as soon as the first living being enters the hallway. Turning the skeletons is at best partially successful as they have nowhere to "flee" except to fight their way through the adventurers, and will drop their swords while doing so. Each skeleton wields an **Animated Longsword**. When a skeleton is destroyed, its sword will continue the attack.

Skeletons (x 12): AC 4 (corroded splint mail), HD 1, HP 7 each, M 15", ATK 1, Dmg d8+1, SA n/a, SD ½ damage from sharp weapons, limited spell immunity, MR Standard, AL N, Size M, XP 21 each

Animated Weapons (x 12): AC 6, HD 3, HP 24 each, M 12", ATK 3/2, Dmg d8+1, SA strike as 7th level fighter, SD limited spell immunity, MR save as "metal, hard", AL n/a, Size S, XP 141 each (see *New Monster*, below)

At the end of the hallway is another door, also trapped. The door is mounted on rails, and the physical effort necessary to force it open will cause the door to fly back on the rails, and the adventurer will topple forward into a pit (15' deep with stakes on the bottom, 3d6 damage) unless they make a Dexterity check at +2 penalty to the roll.

The second room in the tomb complex is the burial room of the warrior-chief. Six armored skeletons are standing and ready to attack, each accompanied by a huge canine skeleton. The skeletons leap to the

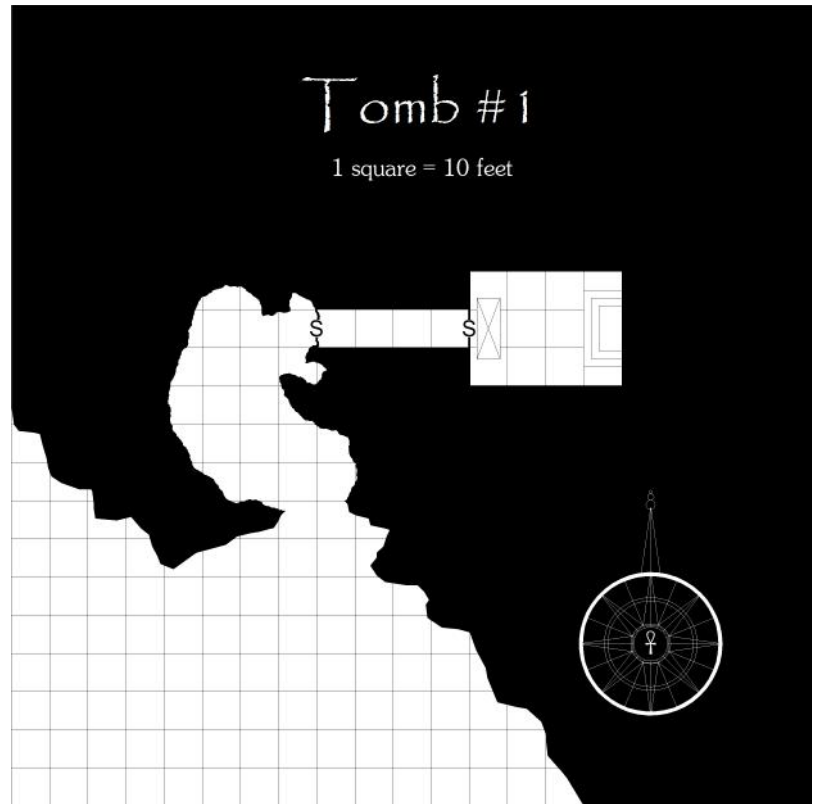

attack, while the warrior-chief rises from his bed and attacks.

Wight (x 1): AC 3 (**Splinted Mail +2**), HD 4+3, HP 35, M 9", ATK 1, Dmg d4, SA energy drain, SD hit by silver or magical weapons, limited spell immunity, MR Standard, AL N, Size M, XP 715

Animal Skeletons (Dire Wolves) (x 6): AC 7, HD 4, HP 25 each, M 15", ATK 1, Dmg d8, SA n/a, SD ½ damage from sharp weapons, limited spell immunity, MR Standard, AL N, Size M, XP 185 each

Skeletons (x 6): AC 4 (corroded splint mail), HD 1, HP 7 each, M 15", ATK 1, Dmg d8+1, SA n/a, SD ½ damage from sharp weapons, limited spell immunity, MR Standard, AL N, Size M, XP 21 each

In addition to the magical splint mail it wears, the wight wears a gold armband (worth 300 gp), and a gold ring with emerald chips (worth 1,100 gp). Leaning against his funeral platform is a corroded long sword (with a silver wire wrapped hilt, 3 gp worth of silver), and a **Large Shield +1**. Engraved on the shield are runes that proudly state (in a long dead tongue) that this is the property of "The loyal Shield-Bearer and Hound-Master of Gorrik Theran".



The last treasure can be found by carefully examining the platform, where a secret compartment is located. The compartment is trapped (poison needle, save vs. poison or die). Inside is a silver box (worth 175 gp) decorated with hound motifs. This box contains 100 gp and six 100 gp gems.

Loose Ends

A number of questions come to mind. Whose tomb is this, and why was he buried here? Who was Gorrik Theran? Perhaps his (or its?) tomb is also nearby?

Tomb #2 – The Bone Guardian

by Andrew Hamilton

The only entrance to this tomb is a sinkhole, where a roof collapsed. Entrance can be gained by dropping through the hole onto the spoil pile. The tomb itself is very plain, essentially a large chamber (40' by 40') carved out of the rock, with a large stone sarcophagus in the centre. The remains of several adventuring parties (14 corpses in total) lie scattered about the room, and a total of 32 skeletons stand at attention, 8 along each wall. These skeletons will immediately attack.

The skeleton guards are actually four bone guardians, magical constructs crafted from humanoid skeletons. In "first generation" form, the bone guardian appears to be 8 skeletons. As the skeletons are defeated and "destroyed", the scattered bones of two skeletons will skitter and slide across the ground, merging to create a "second generation" bone guardian with four arms. A similar merging of two second generation bone guardians occurs to create a third generation bone guardian, and two third generation bone guardians merge after destruction to create an "apex" bone guardian.

Given that there are 32 skeletons to start with, astute players may start doing the math, and not like the potential outcome, which is fine. Let them scare themselves.

Bone Guardians (x 32): AC 7, HD 1, HP 6 each, MV 15", ATK 1, Dmg 1d6, SA recombination, SD ½ damage from edged/piercing weapons, immune to sleep, charm, and poison, ½ damage from cold, MR Standard, AL N, Size M, XP 24 each (18 + 1 xp/hp)

Second Generation (x 16) (AC 6, HD 2, HP 12 each, MV 12", ATK 2, Dmg 1d8 (x 2), XP 60 each (36 + 2 xp/hp)

Third Generation (x 8) (AC 4, HD 4, Hp 24 each, MV 9", ATK 3, Dmg 1d10 (x 3) XP 206 each (110 + 4 xp/hp)

Apex Generation (x 4) (AC 2, HD 8, Hp 48 each, MV 6", ATK 4, Dmg 1d12 (x 4), XP 1,380 each (900 + 10 xp/hp)

Once the bone guardians have been destroyed, adventurers will be able to more carefully examine the tomb. There are three things of interest, the original entrance, the sarcophagus, and the dead adventurers.

The original entrance is sealed from the outside with stone and mortar. Similarly, the entrance tunnel is filled with dirt and rock, and hidden from the outside.

The actual sarcophagus is sealed with a **Stone Shape** spell, and has **Explosive Runes** (6d4 hp damage) carved on it. There is also a warning carved into the lid, "Inside Lies The Great Terror – Hidden Here From The Light of Day". Opening the sarcophagus will require the use of hammers and chisels, and a lot of muscle.

Inside the sarcophagus is a hordling, sealed here centuries ago by local tribesmen because they lacked the magical weapons necessary to destroy the monster. If freed, the hordling attacks without delay, having gone completely insane from



centuries of imprisonment. It will fight aggressively, but use its powers to the best of its ability.

The hordling is an extremely powerful member of its race, roughly man sized (just shy of 6' tall) and very scrawny. It is hairless with coal black skin except for reddish and purple highlights at the extremities. Its head is human-sized, with a huge jaw that has elastic enabling it to engulf something 1' in size. The jaw is filled with ragged, razor sharp teeth. Its eyes glow purple, but they are small (the size of a dime) and sunken. Large, fan-like ears almost form a crest. The creature's arms can stretch to a length of 12', and have wicked claws. Its tail, tipped with barbs, stretches from 3' to 15' in length. The hordling has an effective strength of 18/99.

Hordling (x 1) (AC 0, MV 15", HD 9, Hp 72, ATTK 4 (bite, claws x 2, tail lash), Dmg 2d4 (bite), d6+5 (x2, claws), d4 (tail lash), SA on double claw strike, constrict (d6+5 dmg per round, automatically hit with bite), haste (2/day), SD +2 or better weapon to hit, regenerate 2 hp per round including fire and acid damage, MR 30%, AL NE, Int High, Size M, XP 3,964)

The deceased adventurers include 7 fighters or warriors, 3 clerics, 2 thieves, and 2 magic-users.

Fighter 1 – wears damaged chainmail, with a long sword and round shield in hand, and a hand axe at his belt. In a belt pouch is 12 cp, 11 sp, and 24 gp.

Fighter 2 – wears ring mail, carries a large shield and a club, with a long sword in a scabbard slung across his back. In a pouch on a cord around his neck and under his armor is a 19 cp, 8 sp, and 14 gp.

Fighter 3 – wears plate mail and has a footman's mace close at hand. His discarded two handed sword lies along one of the walls. He wears a gold ring (worth 50 gp), and has a purse (under his armor) with 20 sp, 18 gp, and 6 pp.

Fighter 4 – wears studded leather armor, has a small shield, a broken spear, and a broadsword. He has a purse tucked into his backpack (which contains camping gear) with 34 cp, 18 sp, and 5 gp.

Fighter 5 – wears splint mail, has a sundered shield and battered helm, and holds a footmans' mace. A long sword is in a scabbard at his side, and his

sword belt is decorated with silver studs (60 gpv). His purse (under his armor) holds 31 sp, 6 ep and 13 gp. In the backpack are 3 flasks of oil in steel containers and a tinderbox.

Fighter 6 – a tall, husky female, this corpse wears splint mail and bears a two-handed sword. An ornate but functional silver dagger (75 gp) is tucked into her belt, and a silver holy symbol (50 gpv, local war god) is on a cord about her neck. Her purse holds 29 sp, 7 ep and 5 gp.

Fighter 7 – wears chain mail, has a buckler, a footman's mace, a long sword at his hip, and a quiver of crossbow bolts. His discarded heavy crossbow is at the entrance. His purse contains 12 cp and 9 sp, but he wears a silver bracer (60 gpv), and has 2 100 gp gems tucked in a boot, wrapped in cloth.

Cleric 1 – wears chain mail and has a **Round Shield +1** and footmans mace. She carries a silver holy symbol (50 gpv, of a god of commerce). Her purse (tucked under her armor) holds 19 sp, 14 ep, 27 gp, and 3 pp. In her backpack are some prayer books and a journal.

Cleric 2 – wears ring mail, carries a round shield and a flail, and a holy symbol (50 gpv, to a deity of agriculture). He has a belt pouch (9 sp and 3 gp), and three vials of holy water (3 additional vials are broken).

Cleric 3 – wears plate mail, carries a shield and **Footman's Mace +1**, has a silver holy symbol (50 gpv, of a deity of courage and heroism), and wears a silver armband decorated with agates (worth 110 gpv). In the bottom of his backpack is a journal, some prayer books, and a pouch of 17 gp.

Thief 1 – wearing tattered leather armor, with a very plain looking **Short Sword +2** (due to its properties, this sword does not radiate magic, and has the same effects as an **Amulet of Proof vs. Detection & Location** when carried or held, 5,000 xpv, 40,000 gpv). In a hidden purse are 34 sp, and sewn into his boot cuffs are another 30 pp (15 per boot).

Thief 2 – wears leather armor, and has a short sword in her left hand and a dagger in her right hand, there are another 4 daggers (including one silver



dagger worth 35 gp) tucked in her boots and sleeves. A purse hangs on a cord around her neck with 6 sp, 19 gp and 2 pp, and a carefully folded scroll is concealed in her backpack (illusionist spells cast at 9th level: Blur, Non-Detection, and Minor Creation).

Magic-User 1 – dressed in plain traveling clothes this magic-user is lying face down on top of his oaken staff. In his backpack is a traveling spell book containing the following spells: Armor, Magic Missile, Sleep, Flaming Sphere, and Web. He also has a purse with 34 sp and 19 gp.

Magic-User 2 – wearing the classic robes (with the bushy beard and pointed hat as well), this magic-user wears a golden signet ring (85 gpv, an indication this fellow is minor nobility), and has 6 pp in his purse. There is also a huge sheaf of letters in his backpack that provide more details about his family and identity.

Loose Ends

If the hordling escapes it will begin a campaign of terror in the countryside, slaughtering livestock and families in outlying farms. The adventurers will be blamed for unleashing this horror on the community, and the authorities will expect them to do something about it.

Some of the deceased adventurers have personal belongings that may provide clues to their identities. In particular, the churches of the various clerics would appreciate knowing what became of them, and that they received appropriate last rites.

Selling the noble's signet ring might bring trouble, as the family will find out, and will send agents to investigate what happened. Alternately, returning the ring and possessions of the noble may garner a reward, and demonstrate the party's trustworthiness (which may lead to offers of employment).

Tomb #3 – Mother of All Worms

by Varl

1. Tomb Entrance

The entrance to this tomb is massive. It extends a full 50 feet in width and has a ceiling height of 15 feet. Characters approaching this massive cave opening will immediately notice that, even during the daytime, daylight does not penetrate any further into the cave more than 5 feet. A magical darkness is obviously present, so the characters will need magical light to be able to safely explore this cave-tomb.

They don't need magical light to see what's sprawled out in front of the opening: thousands of small, dry, dead brown worms that disturbingly smash underfoot and roll around in the gentle breeze of the valley. They're everywhere, and they easily extend out the width of the cavern entrance to 20 feet from the cave-tomb's mouth before withering and dying like some macabre, sprawling dead carpet.

Magical light carried by the characters will not dispel all the darkness, nor will the darkness negate their spell. Instead, the characters will be encapsulated within a 15-foot diameter sphere of light, with the light effectively pushing the darkness aside and reforming behind them as the characters move. Once inside the cave-tomb, the characters are immediately overcome by a horrid, nauseating stench (save vs. poison at -1 or retch for one round). The worms, now all living, begin to scuttle and slither towards the characters from all angles, attempting to eat through footwear and climb up legs in search of exposed flesh. The worms have a 5% chance per round of attaching to a character's skin like a leech, and will proceed to burrow in the following round. Fire will kill any attached worms, and they will scurry away from an open flame. Stepping on them and smashing them also kills them by the dozen, but there are so many worms here that the floor cannot be seen throughout the



entire tomb. It's literally a crawling mass of worms, so stomping on them isn't likely to keep them off of characters. Footing is questionable, and movement is reduced to 3" within the cave-tomb to avoid slipping and falling down—something definitely not advisable. Area-of-effect magic is ideal in clearing a path through the worms to maintain movement speeds. A torch can kill 10d10 worms per round of movement, while a spell like **Fireball** will kill 1,000. The DM is advised to adjust these rates to what feels appropriate.

Little Green Worms (10,000): AC 9, HD 1 hp each, Move 1", THAC0 20, No. Atk 1, Damage 0, SA Burrowing into flesh (as per Rot Grubs—see page 83



of the AD&D (first edition) *Monster Manual*), SD Nil, Size T (1/2"–1" long), AL N, XP 1 each.

One suggestion is to have the little green worms attack 10 or 20 at a time. The power of this should not be underestimated. Although each one has only a 1 in 20 chance per round to attach to a character's skin, many worms can attempt to attach each round, while removing just one attached worm takes a full round. Thus it is not difficult to see how quickly a PC could be overwhelmed by sheer numbers.

[DM's Note: Feel free to adjust this according to taste, player skill, character level, etc.]

2. Sarcophagi

Within this cavern, six sarcophagi are placed side by side. The little green worms are in here as well, but there are much fewer than in the main caverns. Sarcophagi 1 is empty and missing its lid.

Sarcophagi 2 has its lid in place, slightly askew. An ancient inscription is on the surface of the lid, but time has eroded it, making it unreadable and unidentifiable. Prying this sarcophagi open reveals a tattered skeleton in rags, with the remnants of a

container of some kind. Scattered on the bottom of the sarcophagi are 34 cp, 77 sp, 18 gp and a small gold ring (worth 50 gp), which is non-magical.

Sarcophagi 3 is sealed tight. In order to pry it open, the characters must chisel and hammer at the lid edge to break it free enough to slide it open. It contains the moldering remains of a female human and two children, entombed here after their deaths. All three mummified corpses rise and attack!

Mummies (3): AC 3, HD 6+3, hp 47, 34, 31; Move 6", THAC0 13, No. Atk 1, Damage 1–12, SA Fear, disease; SD see the 2nd edition AD&D *Monster Manual*, p. 261, Size M and S (5 feet, 2 feet

and 2 feet), AL LE, XP 3,000 each.

The children mummies have no treasure, but the female mummy is wearing a silver chain around its neck with a huge aquamarine pendant (worth 3,140 gp), and it is non-magical.

If the characters flee this cavern without destroying the mummies, the worms will begin to climb onto and cover the mummies head to toe, utterly



consuming anything organic left on the corpses in a couple days.

Little Green Worms (100): See area 1 above.

3. Forgotten Pit Trap

At this location is a 10-foot x 10-foot pit trap. The trap's lid is broken and has been jammed partially open by stone debris. Many of the same grotesque green worms fill this area, and if characters weighing more than a combined total of 350 lbs. step onto the lid, they will inadvertently break the pit lid free from its debris jam and quickly sink up to their waists in a pit filled with squirming, disgusting little green worms. (This is similar to sinking halfway into quicksand).

Characters that sink into the pit are in serious trouble, for the worms have a much greater chance at attaching. The chance of attaching increases to 20%. Characters outside the pit area are advised to use rope to free friends that have fallen into the mass of worms. Stretching and reaching out to them by hand is possible, but dexterity checks must be made by those outside the pit attempting to help to avoid being pulled in.

4. As If There Weren't Enough Worms...

Characters moving into this cavern notice two corpses that are completely covered in worms. Approximately human-sized, the corpses are obviously undead of some kind, but what kind they are is impossible to tell because of all the worms crawling over them.

As the characters observe this gruesome spectacle, both undead reach up to their heads, grab handfuls of little green worms and begin throwing them at the PCs!

Worm-covered Sons of Kyuss (2): AC 10, HD 4, hp 27 each, Move 9", THAC0 17, Attacks 1, Damage 1-8, SA Fear, worms, disease; SD Regeneration, Size M (6 feet), AL CE, XP 215 + 4 per hp each. (For more information, see page 83 of the *Fiend Folio*.)

There is a 3% chance with each throw of worms that the Sons grab and throw some of their own worms as well. Characters can make perception checks at -4 to notice a different worm being thrown at them.

5. The Mother of All Worms

Sprawled and blocking the entire northernmost passageway in this area is an abomination many adventurers have likely never seen. A massive green worm, measuring some 30 feet in length and 5 feet wide, lies in the area. It is covered with a myriad of orifices (about 30), and it undulates and wriggles within the confines of the cavern. She is also covered by thousands more of those little green worms, and every once in a while, an orifice or two vomits out dozens more of the disgusting creatures, seemingly involuntarily. This creature is spawning them!

If the Mother is approached, the little green worms immediately attack, sensing a threat to their parent, and attempt to climb on and burrow into characters as above. If the Mother is attacked, she defends herself by spewing streams of little green worms at the characters. She can also shoot a stream of acid from any orifice 5 times a day out to a range of 30 feet. She shoots these acid streams when under direct attack, but otherwise shoots forth worms in defense. Characters struck by the acid stream must save vs. breath weapon or suffer 2-16 points of corrosive damage, and metal armor and equipment must also make item saves to avoid item destruction per hit (see page 80 of the first edition *AD&D Dungeon Masters Guide*). Mother is particularly vulnerable to fire, suffering double damage if she fails to save. If killed, she explodes into a massive shower of goo and chunks of gore, which cause no damage but force characters to save vs. poison at -1 or spend the next round vomiting from the stench and sheer horridness of her death.

Upon the death of Mother, the little green worms lose the biological link they have with their parent and become docile and dormant for 1 day. After that day, one specific worm amongst the thousands available begins to feed upon its kin, gorging itself



relentlessly until it eventually grows into another Mother. This process takes a month. Halfway through its development, it starts to spawn worms of its own, thus adding to the depleted worm count and helping to feed itself at the same time.

Little Green Worms (5,000): See area 1 above.

Mother (1): AC 10, HD 6 (44 hp), Move 1", THACO 15, Attacks 1, Damage 2-16, SA Spew worms, spew acid, SD Nil, Size H (5' wide x 30' long), AL N, XP 5,000.

Tomb #4 – Tomb of the Gnome Prince

By Jeremy Dow

The wall or door that once denied access to this tomb is long gone; all that remains is rubble strewn about the wide open entrance. The entrance reveals a passage that is ten feet wide until the natural passage begins farther ahead (see map).

1a. A puddle of the Cave Sundew's adhesive drippings lies on the ground directly below the vertical shaft where the creature lurks. The puddle fills the width of the passage (ten feet) and is roughly ten feet long. Careful inspection of the floor will reveal a few bones from small rodents as well as gleaming coins (10 cp, 8 sp, 5 ep, and 6 gp). The monster will attack with its tentacles as soon as any creature gets stuck in the puddle.

1. **Cave Sundew** (see page 41): AC: 8 (body), 5 (tentacles); HD: 6; HP: 24 (body), 6 (each tentacle); Size: Huge; Intelligence: Low; Move: 1"; # Attacks: 1-4, depending on how many tentacles are free; Dmg.: 1-10 from each tentacle, plus adhesive; SA: *Adhesive*: Upon a successful melee attack, target must save vs Paralyzation or be stuck to the tentacle's fibrous end; Alignment: Neutral; XP: 2,136.

2. Water seepage has gradually eroded the walls over the years, forming the opening and downward slanting tunnel, which extends downward and then bends back upward, forming a V shape. The tunnel varies from roughly three to five feet in diameter and is

filled with water. Moving through this tunnel requires one to hold one's breath underwater. This can be done for one segment per point of Constitution of the character, with Constitution bonuses for hit points conferring the appropriate number of bonus segments. Thus, for example, a character with a Constitution score of 18 could hold

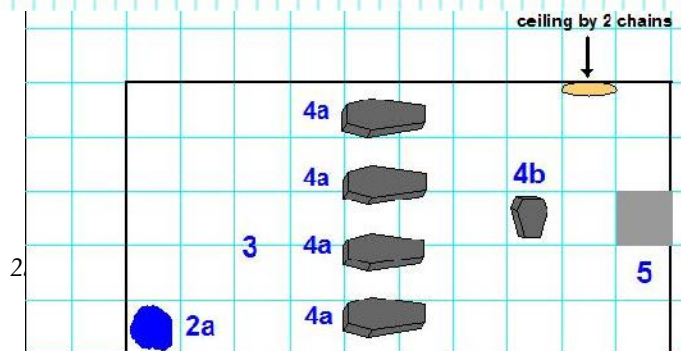
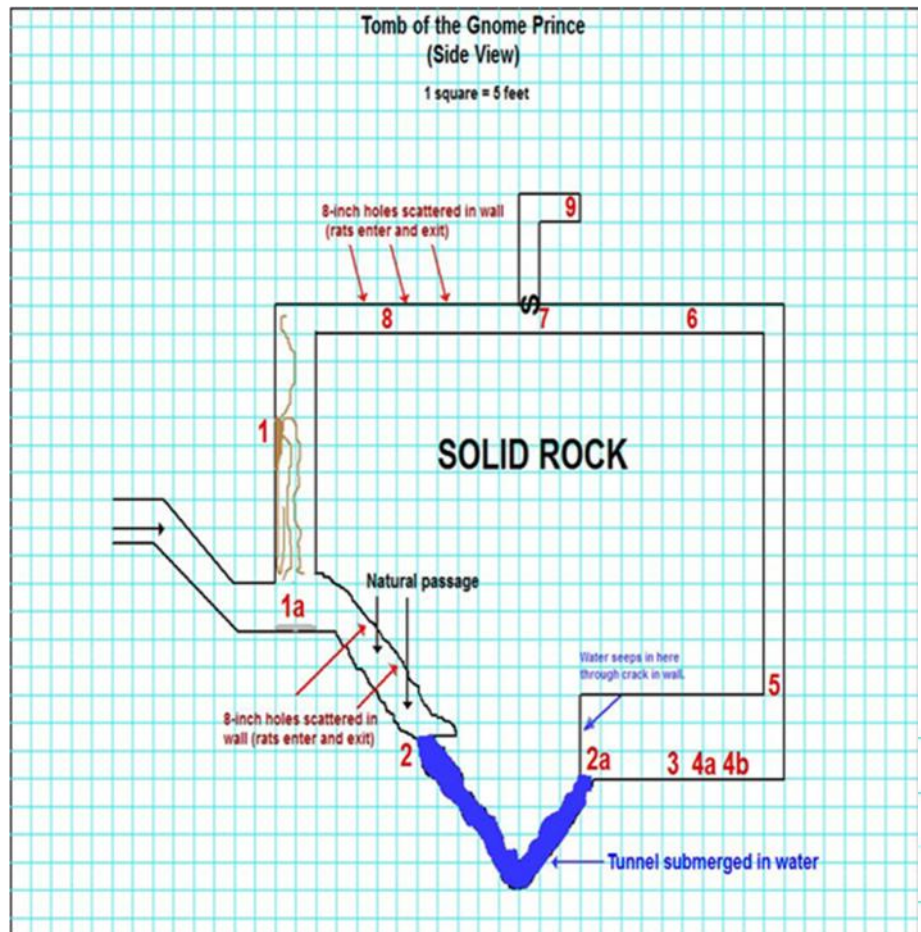

his breath underwater for 18 segments (132 seconds, or two minutes and 12 seconds): $18 \times 6 = 108$ seconds + 24 (Con bonus of four segments) = 132. In addition, although a completely unencumbered character has a normal dungeon movement rate underwater (see the *Dungeon Masters Guide*, p. 56), due to the cramped space in the tunnel, movement will be at one-fourth normal speed, whether encumbered or not.

2a. The water-filled tunnel opens here in the tomb.

3. A Necrophidius (see the *Fiend Folio*, p. 67, for complete information) guards this chamber and will attack any who approach: AC: 2; MV: 9"; HD: 2; HP: 12; THAC0: 19; #AT: 1; Dam.: 1–8 plus save vs. paralyzation or be paralyzed for 1d4 turns; XP: 142; SA: Surprise on 1–3 on d6; if it does not surprise, it will do its *Dance of Death*: All observing must save vs. magic or be unable to act (as hypnotism). Note: The Necrophidius is not undead and therefore cannot be turned.

4a. There are four minor flesh golems here, one in each sarcophagus (each is plain-looking): AC: 9; HP: 13 each; HD: 2+3; THAC0: 16; #AT: 2; Dmg.: 1–6/1–6; MV: 8"; Size: 7.5 feet tall. They can be hit by normal weapons. They have no treasure. See area 4b for how they are activated.

4b. This sarcophagus is much smaller than the other four and contains a long-dead gnome corpse, once dressed in fine apparel. The outside of the sarcophagus is gold-plated (worth 2,000 gold pieces) and expertly carved with artful designs.

There is nothing unusual about the gnome corpse inside. It is not undead and poses no threat. The sarcophagus is trapped, however. If the lid of the sarcophagus is removed and remains open for one round, a small metal ball will shoot out from the

wall directly opposite the bronze gong, striking the gong and creating a deafening noise. All in the chamber must save vs. Paralyzation or be stunned for one round. The noise also immediately activates the four minor flesh golems in the other coffins (4a), who emerge from their sarcophagi in the same round and attack any intruders.

There is no treasure inside the coffin. The dead gnome's valuables are stored in the secret chamber (see area 9 below).

5. A 5-foot-square opening in the ceiling here leads to a vertical shaft.

6. Trap: A heavy stone block will strike downward from the ceiling, causing 2d8 hit points of damage, half damage if a successful saving throw vs. Paralyzation is made. The stone block will return to its position in the ceiling and fully reset in one round.

7. A secret trapdoor is set here in the roof of this cramped tunnel. It opens to a 5-foot-square vertical shaft that extends 20 feet upward. Near the top a passageway opens to area 9.

8. Trap: Same as trap in area 6.

9. Treasure room: This is really a dead-end passage and not a room, being only five feet wide, five feet high, and ten feet long. Two chests (each guarded by a poison needle trap: Save vs. Poison or die (DMs can make this nonlethal by letting a failed saving throw result only in a drop to –1 hit points.) **Chest #1** has 56 p.p., 300 g.p., 500 s.p., and 10 garnet gems, each one worth 500 g.p. **Chest #2** has a +2 short sword, a Potion of Clairvoyance, a +2 Scimitar, and a Wand of Lightning with 84 charges (see page 135 of the *Dungeon Masters Guide*).

Tomb #5 – Traps and More Traps

by Andrew Hamilton

The entry to this Tomb is concealed by a permanent illusion, looking like the natural sandstone of the cliff. Unfortunately, erosion has changed the face of

the cliff, and now the illusion creates the appearance of a cliff face about 3' in front of the remainder of



the cliff, actually drawing attention to the tomb entrance.

1) The Trapped Entrance

The entrance to the tomb is a series of three trapped doors. The entry door is set into an alcove, and is mortared shut. The trap here is a deadfall that is held up in place by the door. Forcing the door open drops the alcove roof (for 4d6 hp of damage).

The second door (5' in from the first door) is mortared and spiked into place, opens outward and must be chiseled loose. When it opens, a spiked ball swings down from behind (inflicts 2d6+2 hp) and the threshold is trapped with a **Glyph of Warding**.

The area beyond the second door is an empty 10' by 10' room, the floor of which covers a pit 20' deep. The third door, situated directly across from the second door, is false, and when opened the floor drops away into the 20' pit.

2) The Hall of Memory

The real tomb entry is a secret door 15' up the pit wall. It leads to a short hallway, the walls of brick and plaster, decorated with a tile mosaic showing the life of a skilled warrior-priest defeating enemies, aiding the poor, raising sons, blessing marriages, etc.

There are two tombs hidden behind secret doors behind the mosaic. Because the doors have been plastered and tiled over, they will not be noticed by an elf passing within 10'. They must be found during a regular search.

The north wall has imagery that includes chests and boxes, all of which are closed except one. These images include a foot on a closed chest, a box tucked under the warrior-priest's arm, and the warrior-priest standing in front of a defeated enemy holding up a closed coffer. One image with an open

chest shows the warrior-priest dispensing coins from an open box to a crowd.

The south wall has imagery that includes books. One scene has a closed book held under the warrior-priest's arm, another has an image of a book being handed from one person to another, and a third image is of a mace, helm and book on a table. The fourth image is of an open book on a lectern.

At the end of the hallway is a false door with an engraved message "Find Here the Legacy of Corlan the Great, Wizard-Priest of Enkar", followed by several lines of "Blessed by the Faithful of the God of Light and Hope", etc. There are also 2 series of **Explosive Runes** (6d4 hp damage) inscribed on the door, and if the door is opened (requiring two rusty

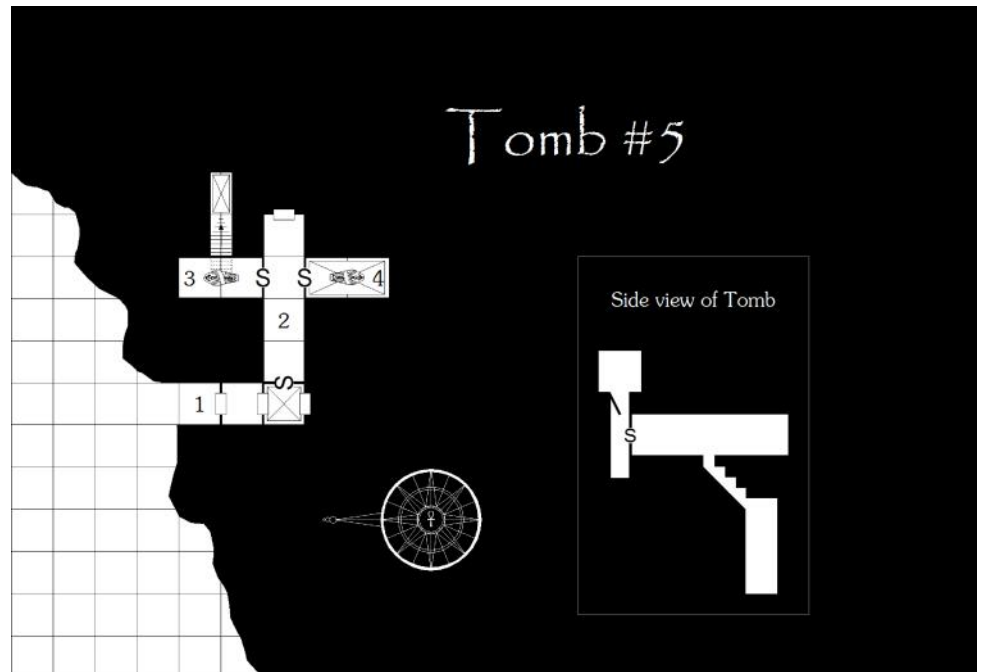

locks to be picked (-10% chance each), each with a paralyzing poison needle (save vs poison or paralyzed for 1d4 hours) a fire-trap (1d4+12 hp damage) will detonate and an unfinished rock wall will be seen.

3) Illusionary Foes

There are three images of chests on the north wall, only one of which is open. Breaking the tile and plaster here will reveal a door that opens to a 10' x 20' room with a sarcophagus in the centre. Upon entry a programmed illusion will be triggered,



causing a spirit seemingly to coalesce from the dust and rush to the attack (treat as an illusionary spectre). Removing the sarcophagus lid reveals stairs down. The stairs are trapped, becoming a slide that drops anyone on them into a 20' deep pit with spikes on the bottom (4d6 damage). A stone lid then slides shut, sealing the pit, and a second programmed illusion is triggered (of the wall crumbling away in 10 locations, releasing 20 skeletons dressed in bronze armor, with bronze shields and swords. Each illusion fights as a 3 HD creature, and rises again 1 round after being defeated, the illusion runs for 12 rounds before winking out of existence.

DM Note: Both sets of illusions lack sound, which may give astute players an increased chance of detecting the illusion.

4) True Tomb

The true tomb is hidden behind the open book mosaic (there are four books on the south wall, three closed). If the sarcophagus lid is moved, the floor

around the sarcophagus drops away into a 20' deep pit (the sarcophagus is on a column/pillar). Inside the sarcophagus is a mummified body (not animate). Buried with it is the following:

A gem-set holy symbol (worth 150 gpv). Anyone taking this will suffer the effects of a curse spell for 1 year and 1 day.

A golden torc set with jade (worth 3,000 gpv). Anyone taking it is cursed to receive the minimum healing effect for 1 year and one day.

A gold box (worth 100 gpv). Opening it sets off a fire trap that inflicts 1d4+12 hp damage.

A silver ring (35 gpv apparent value, actually a **Ring of Protection +1**, but coated with a contact poison that will not work until the skin gets wet, at which point the hand and arm begin swelling (making removing the ring impossible without removing the finger). The swelling is agonizing, and continues to spread to the entire body. Damage is 1d4 hp/round for 3d6 rounds (a successful save reduces damage to 1 hp/round for 3d4 rounds).

Tomb #6: The Pharaoh's Tomb

by Patrick Fazekas

This tomb sets in the middle of a large opening in the forest. Within a 100' radius of the tomb nothing grows. The tomb is clearly ancient, possibly one of the oldest in the valley. Blown dirt has piled up along the sides.

The Pharaoh's tomb is a 70'x70' marble pyramid whose only visible means of entrance is double

stone-slab doors, each 5' wide by 8' high. There is evidence that others have been here in the past ten years as the accumulation of blown dirt has been cleared away from the doors so they can open. The doors open once the party finds and presses the middle panel on the left door.



The Entry Hallway

The entry hall is an unremarkable 15'x10' stone hallway lined with bronze braziers on the walls. The way leading to the burial chamber is another set of stone-slab doors, but with handles to open.

Plate P1. This pressure plate is a tile in the floor, 5' in front of the doors. The plate sinks into the floor 3" when stepped on. When the plate depresses, there will be an audible grinding of gears from above and then compressed poison gas sprays into the hallway. All characters in the hallway must save vs. poison. Those saving will suffer 1d4 points damage, and those who fail suffer 2d4 points of damage. This is a one-use trap, once triggered it does not automatically re-arm itself.

The Interior Hall

The Interior Hall is a 10'x20' room attached to a 10' x 10' hallway ending in double stone-slab doors. The walls are lined with bronze braziers.

Plate P2. This pressure plate is a tile in the floor, 5' in front of the doors. The plate sinks into the floor 3" when stepped on. When the plate depresses, there will be an audible grinding of gears from above, and the 10'x10' pit trap 5' behind the plate will activate. Any characters backing onto or standing on the pit will fall in without a saving throw. Characters falling in the pit will suffer 1d6 points of damage

The Burial Chamber

The Burial Chamber is a 25'x30' room lined with bronze braziers and elaborate paintings on the walls. There is a large 5'x10' coffin in the room, sheathed in gold, ivory, and jade. The coffin is flanked by 10' tall statues of jackal-headed humans. The statues are made of black marble, detailed in gold, and with fig- sized topaz gems for eyes. The statues have a malevolent feel to them, and have empty, haunting gazes.

Behind the coffin is a scattering of bronze, brass, and silver weapons and coffer.

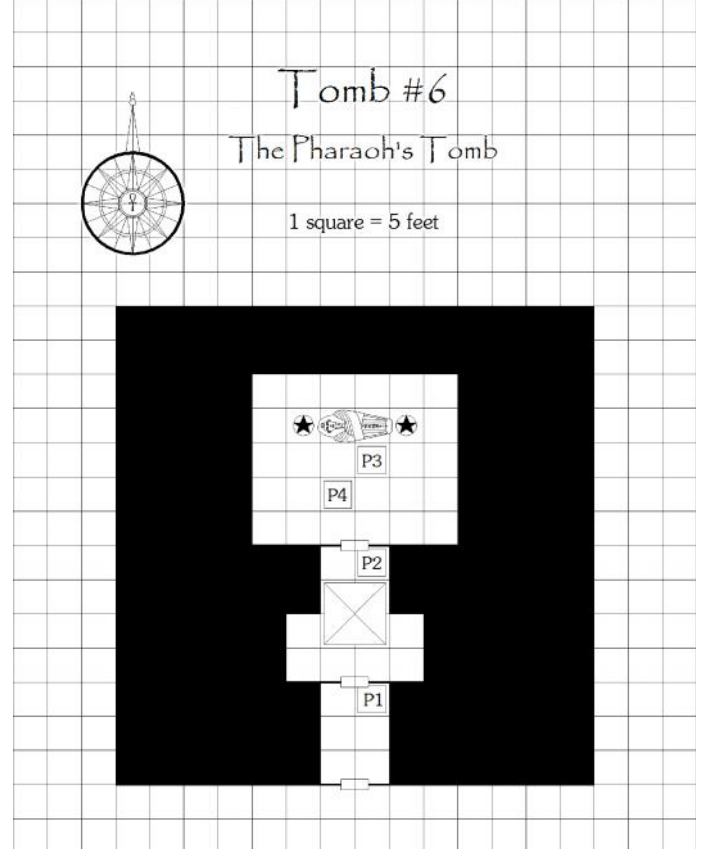

Clockwork Anubis statues; HD 7d6+4; Mv 12"; AC 0; # Att 1; Dam/Att 2d8; Int non.

The statues are black marble, gold detailed figures in the semblance of Jackal-Headed humans (Anubis). They are mostly mechanical clockwork statues, with just enough magic to power their basic thought processes and make them appear as statues. They will not be detected by a *Detect Magic* or *Detect Trap* spell. [See the New Monsters section for a complete description.]

Plates P3 & P4- These tile plates are fakes. They will stand out to anyone who has seen the first two plate traps. Stepping on either plate will produce the sound of grinding gears from the ceiling, but nothing will happen.

Pseudo- Treasure

Within the Burial Chamber is a fair amount of wealth, though it is not the actual treasure. The pseudo-treasure is as follows:

- 20 assorted, finely crafted bronze weapons. They are valued at about 5 gp each
- 5 bronze coffers, filled with 500 cp each. The coffers are worth 7 gp each



- 5 brass coffer, filled with 500 cp each. The coffers are worth 10 gp each
- 5 silver coffer, filled with 500 sp each. The coffers are worth 20 gp each

The Real Treasure

If the party searches the coffin they will find a concealed jade button on the back of the coffin. When pressed, the button will depress a latch, which will open a tile on the floor. The opened tile reveals a ladder leading down. However, at the same time, pressing the button will activate the Anubis statues.

The ladder leads to a 30'x 30' room filled with treasure. It is scattered with gold and silver coffers, ceremonial daggers, a golden scepter, scroll cases, goblets, a boat, and a gold coffin containing the dead pharaoh.

The treasure is as follows:

- 5 silver coffers, filled with 1,000 silver each. The coffers are worth 200 gp each
- 5 gold coffers, filled with 1,000 gold each. The coffers are worth 500 gp each
- A small Ivory coffer, etched in platinum, filled with 500 mithril coins. The coffer is worth 2,000 gp
- 10 assorted gold and silver ceremonial daggers, worth 150-200 gp each
- A jade scroll case (20 gpv), containing magic user scroll with the following spells cast at 7th level: Fireball, Wall of Ice, Magic Missile.
- 20 assorted gem inlaid, gold goblets. They are worth 100 gp each
- A golden scepter worth 500 gp
- A finely made, 18 ft. boat. As the boat is 5,000 years old, it is not seaworthy and is completely worthless

Tomb #7 – The Forgotten King

by Jay Goodenbery

Centuries ago, the king of a long-fallen kingdom was carefully preserved and interred here. None alive are likely to have ever heard of him or his realm, though searching musty tomes or old histories could unearth stories about him.

1) The False Tomb

The front door of the tomb is a huge bronze portal, scribed with runes and glyphs (most are warnings against grave-robbing, but one is a Glyph of Warding cast by a 12th level cleric, which deals 24 points of electrical damage to anyone who tries to open the great door). The runes are in a dead language, but a Comprehend Languages will reveal their nature.

Inside is a small chamber, the walls engraved with a bas-relief showing the deeds of the king (triumphing over his enemies in battle, passing

judgment from his throne, casting down demons, and so forth). At the far end is what appears to be a stone door, this one also covered in engraved runes (these recite the lineage and titles of the king).

Standing before it is a statue of the king, clad in rich robes, a torc-collar bearing a scarab, and an elaborate metal headdress, holding a rod of office. In each corner stands a stone statue of a warrior clad in a skirt, breastplate, bracers, greaves, and helmet; each holds a stone khopesh sword crossed over their chest. Their faces are grim and they wear a narrow beard with no mustache. Laid before the foot of the king-statue are a scattering of coins (32 sp, 18 ep, 24 gp, and 7 pp), several small clay or pottery dishes holding small amounts of long-dried and desiccated matter (once flowers or food offerings), and scraps of ancient, brittle parchment (poems or prayers), that are likely to crumble to dust if disturbed.



Once more, a Comprehend Languages will reveal the inscription. It reads something like the following (DM's can elaborate based on their own campaign world):

Here lies Dankara Garai, Fourth of His Name, Sha stone ker of the Heavens, Vanquisher of the Scions of Val-Kur, Master of the Sapphire Scarab, Smiter of the Unworthy, Whose Fists are the saviors of his people, Beloved of Denjera of the raven hair, son of Chuma the Foe-Slayer, son of Gyasi the Wise, son of Khalid the Twice-Born, etc., etc. in the same vein for several paragraphs.

The stone door is actually a false door, and cannot be opened. The real door to the burial chamber is a secret door in the left wall; it is opened by pressing in the scarab on the king-statue's throat.

If anyone touches either the false door or the king-statue, the four warrior-statues will animate and attack any intruder, until all are slain or fled (after which they will resume their positions). They will remember intruders and attack them immediately upon re-entry, and will also attack anyone who strikes them.

Stone Guardians (x4) (AC 2, MV 10", HD 4+4, Hp 30 each, ATT 2, Dmg 1d8+1/1d8+1, SA none, SD 1/4 damage from edged weapons, immune to normal missiles, 1/2 damage from cold/fire/electricity, other various immunities, MR special, Int Non, AL N, Size M, XP 790 each.

2) The Way Down

Beyond the secret door is a short, narrow (5') passage, leading to a vertical shaft that descends to the actual burial chamber. The shaft is a hewn stone chimney, about 4'x4', and descending 60' to a sandy floor. Midway (30') down this shaft is a trap, triggered by any pressure on special plates in the walls (if the PCs can descend without touching any of the walls, the trap will not be triggered). If the trap is triggered, scything blades will sweep across the entire shaft; anyone in their path (the person tripping it, typically) will take 2d8 damage. Note that this will also automatically sever any rope

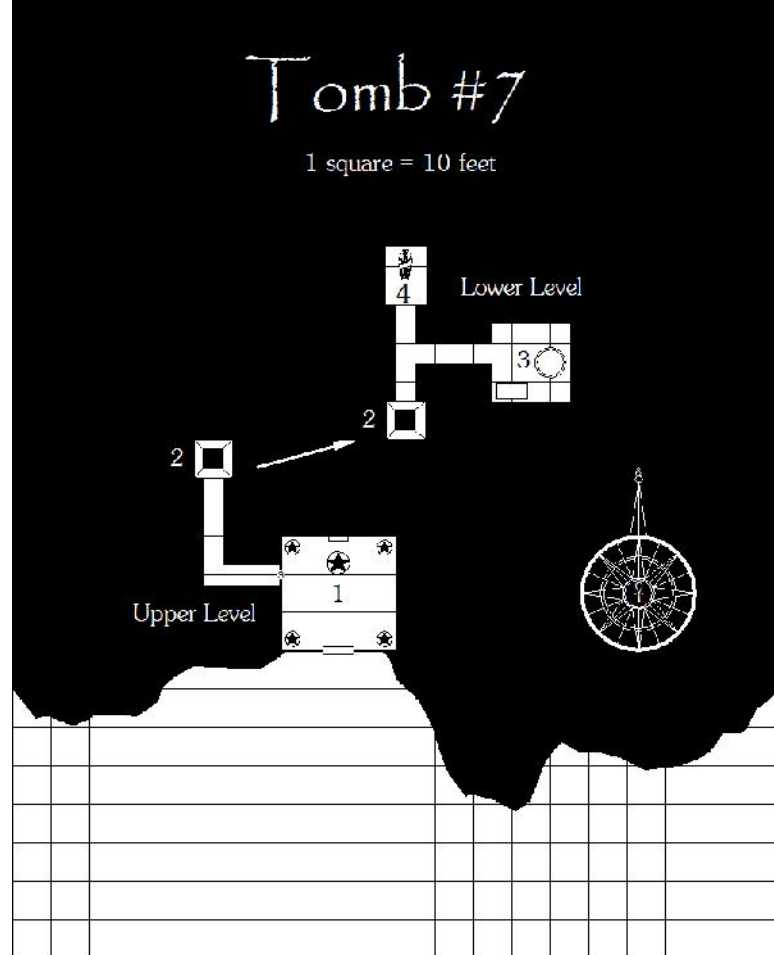

going down the shaft at this point; someone struck by the trap while climbing down must make a save vs. Paralysis or lose their grip and fall.

The trap can be detected in the normal fashion (by a thief). Because the walls of the shaft are so smooth, anyone saying they pay close attention to the walls should also be told about the unusual crack (for the blades) that runs all the way around at the 30' point (assuming they have sufficient light to see, they should have a warning before the trap is tripped). The pressure plates are very carefully set, and will not be seen by visual inspection (except by a thief who made a successful Find Traps check).

A thief climbing down (with hands) or anyone descending the shaft by bracing against the sides will automatically trip this trap if it is not detected. Someone descending with a rope is 40% likely to trip it, unless they specify that they are bracing their feet against the walls (automatic) or that they are taking care not to touch the walls (never).

The trap automatically resets, and can strike any number of times.



3) The Embalming Room

Off a side tunnel lies the place where the king was prepared for his interment. This room is a plain stone room, containing nothing but some ancient and fragile wooden shelves, a large (4'x8') stone table, and a round stone tub or basin (8' across, about 4' deep) set in the floor. The basin is empty, but crusted with white powder (chemical residue, from bathing the corpse in preservatives).

The table holds a few scraps of linen, some dry powder or dust (remains of spices and herbs), and a bronze knife (perfectly ordinary, but worth 4 gp, perhaps 5-10x that to a historian or collector).

The shelves hold some old clay jars and pots, most of which are filled with worthless powder and crumbling residue (again, remains of herbs and spices used in the embalming process). A few are still sealed with wax. One contains oil of myrrh (worth 10 gp, but considerably more to a temple or anyone interested in preserving the dead or creating mummies); if used to treat the bandages when creating a mummy, that mummy will have +1 HP per die and +1 to all saves. Another contains several old dried leaves; these are high-quality black lotus, a powerful and dangerous drug (worth 400 gp, but highly illegal in most civilized lands). Finally, on the bottom shelf is a tiny bottle holding Oil of High John the Conqueror (originally from Dragon Magazine #33; grants a +3 bonus to any weapon anointed with it for 24 hours).

4) The Burial Chamber

This small room holds the last earthly remains of King Dankara. The walls are painted with murals depicting the land of the dead (mostly rivers and weeping willows, albeit with a somewhat creepy motif). In each corner is a bronze stand lamp (unlit, but filled with oil). Against the far wall is a carved stone sarcophagus containing the king, who is

(naturally enough) a mummy. He will not react when his coffin is opened, but will spring to life when he is touched (surprises on 3 in 6) or attacked. He is well-preserved, and his wrapped body is clad in finery: his golden headdress set with stripes of lapis lazuli (worth 500 gp); a golden death mask covered with fine engraving (worth 150 gp); his golden torc-collar, bearing a scarab carved from a sapphire (worth 1150 gp, but see below); a gilded breastplate set with turquoise (worth 175 gp); rich robes (now quite old and of little worth), and his rod of office, made of ebony and capped with gold at either end (worth 125 gp, but see below).

Mummy (AC 3, MV 6", HD 6+3, HP 50, ATT 1, Dmg 1d12, SA Fear, Disease, SD immune to normal weapons, half damage from magic weapons, immune to cold, other various immunities, MR special, Int Low, AL LE, Size M, XP 1550)

The king's rod of office is a Rod of Smiting (14 charges remaining). The scarab set in his torc will radiate powerful magic (conjuration and alteration). When the mystic command words ("Kaa-Jee-Daa") are spoken, the wearer of the scarab will be clad in shining azure Chainmail +3, which also grants the wearer the unarmed combat abilities of a 9th level monk (2/1 attacks for 3-12 damage each, plus chances to stun and kill as normal). The armor can be dismissed at will by touching the scarab, and can be summoned or dismissed as often as desired.

Loose Ends

The special **Ring of Protection** that will protect one against these Stone Guardians was entrusted to the royal vizier of the fallen king; he died sometime later, and the ring was lost. If PCs could somehow find or locate the ring (by a special quest, or perhaps by lucky happenstance), it would make robbing the tomb much easier.

Tomb #8 – Deathtrap

by Nicole Massey



DM's Note: This crypt sits in plain sight, intended by its builders to be part of the defenses of this sacred Valley. The crypt has a plain stone face, lacking ornamentation. The entry doors are made of thick oak, jacketed in bronze, and very well attached to the door frame. The doors are locked shut with a thick iron bar (as described below).

As you approach the crypt in front of you the path is mostly overgrown, making it clear that no one has been there in a very long time. The crypt is mostly overgrown, the iron bar locking the bronze doors into the crypt is rusty and glistens with an eerie shimmer, and the name above the door – Everfair – can only be read after some effort. The remains of several skeletons lie outside the door along with some rusty armor and weapons.

The moment someone touches the crypt, a voice booms out, "Despoilers! Do not enter this tomb lest you face a death most swift and an end to all that you found desirable in life. None who enter leave alive. This is your only warning."

DM's Notes: There was never an Everfair family. When the necropolis was established several tombs of this type were created, though the rest have decayed to the point where they no longer function.

There is no treasure in the tomb, and no corpse either, just deadly traps to eliminate any potential tomb robbers.

First, there's the lock on the iron bar. It's a special type, with six rotating poison pins that must all be disarmed to open the lock. Touching the lock will require a save vs. Poison at -2 to keep the person who touched the lock or locking bar from dying in 2d4 rounds from contact poison that eats flesh away. The lock will also have to be opened using an object, as pins slide out of the lock sides and the insides and outsides of the locking hasp to deliver the same poison.

Anyone entering the crypt will see an empty room twenty feet on a side with a black floor of some unknown stone. Count softly backwards from twenty and at zero the floor, a force field, disappears. Beneath the party is a 400-foot shaft. The space down to one foot above the floor is an

anti-magic zone in nine-foot-and-eleven-inch sections, with a one-inch section between each field consisting of vorpal wire (akin to monofilament) arrayed horizontally in a net (except for the first one-inch section—see below). Any material caught in the wire is teleported back to the top right under the level of the floor, while anything that is severed by it goes on for "further processing" below in identical nets. Feather fall spells and any spell cast after the fall starts won't work unless the player rolls 00 on percentile dice, meaning that the spell goes off in one of the inches where the field isn't working, but then he or she has to contend with the vorpal wire net. An anti-magic shell also activates surrounding the crypt and a 40' radius around it.

To add insult to injury, the first one-inch section has, instead of a vorpal net, a programmed teleport that will teleport all metal or glass on the falling character to the spot outside of the crypt.

Falling is at double the normal falling rate, as small pinprick-sized holes dot the walls, creating a suction effect in the abyss. Woe to anyone who tries to go to gaseous form.

A vorpal net will dice the falling person up into a grid $\frac{1}{2}$ on a side, while the suction will cause things to pivot and tumble, so that soon the person is at best a collection of half inch cubes, though of course very messy.

Any object with a high calcium content will likewise be teleported to the outside when hitting the bottom – anything else will be teleported back up to the level just below the force field floor to make the fall again. This teleportation field is six inches above the final floor.

Every fourth vorpal web has an astral component – making it an excellent way to cut a silver cord.

Award 1,000 experience points for any character that heeds the warning, and give no experience for any character that enters.

Finally, there is a very nasty surprise waiting at the bottom if a caster manages to cast a **Dispel Magic**: the space under the teleport field is a flattened out sphere of annihilation.



Finally, just to add insult to injury, in the one inch spaces are programmed magic mouths that laugh when anything passes by them, peals of mirth ringing out for about a minute after each one is triggered.

The only treasure in this crypt is located in a niche in the top – this is where the unseen servant tasked

with applying the poison every six weeks keeps its supply of the stuff, which it makes from plants growing around the crypt.

Note: Vorpal nets will cut through mithril or adamantite with no problem.

Tomb #9 – Spider Lair

by Andrew Hamilton

This tomb has been breached and emptied by a pack of ghouls, leaving behind an empty complex which has become the home to a nest of stirges and a giant spider.

1) The Spider Web

The entry way has hanging webs, and the remains of several small bats can be seen (there are many dark little nooks and crannies in the cliff face here for bats to lair in). A giant spider lurks here, and will attack anything disturbing the web. The web is very sticky, and the spider can make the web collapse, trapping characters.

Giant Spider (x 1) AC 4, MV 3"*12", HD 4+4, HP 29, ATK 1, Dmg 2d4 + poison, SA webs, poison, SD nil, MR Standard, AL CE, Int Low, Size L, XP 385.

2) Hall and Deadfall

The doors and seals in this tomb have all been torn open, and several traps set off. A ghoul's remains can be found under a stone block between the doors to areas 3 and 4, the result of a deadfall trap set off by the ghouls.

3 & 4) Burial Niches

Each of these 40' long hall ways contains eight burial niches (four pairs, one niche at floor level and one at chest height). The niches were originally

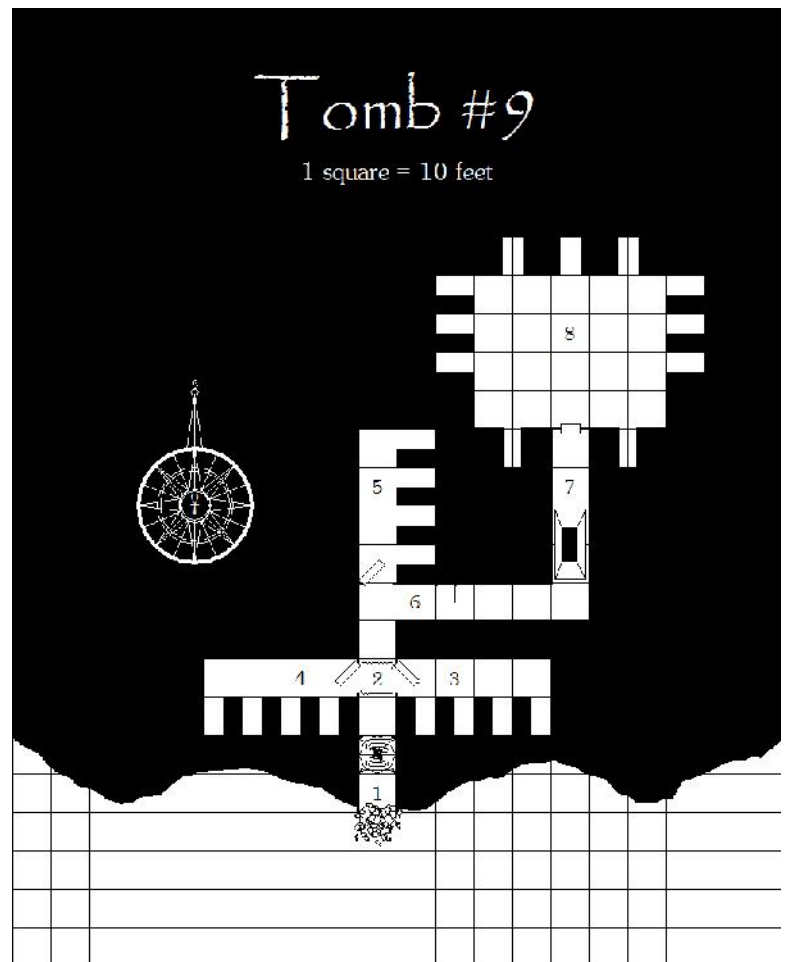

bricked shut, but they have been torn open by ghouls, the contents consumed or scattered about. Sorting through the debris will find nothing of value.



5) Stirge Nest

The stirges hide back in the tomb. They have learned to avoid the giant spider web, and the giant spider has learned to be cautious of the stirges, since they swarmed and killed two other giant spiders.

Stirges (x 13) AC 8, MV 3"/18", HD 1+1, HP 5 each, ATK 1, Dmg d3, SA blood drain, strike as 4 HD creature, SD nil, MR Standard, AL N, Size S, Int Animal, XP 46 each (36 xp + 2 xp/hp).

6) Spear Trap

This trap has already been triggered, and the remains of a ghoul hang impaled on two spears is visible.

7) Pit Trap

This 30' deep pit was once concealed by a tarp covered with mud and dust to make it blend in with the floor. Now it is open, and the remains of two ghouls lie at the bottom. Investigation reveals that

one ghoul survived the fall and feasted on its pack-mate before succumbing to hunger.

8) Main Tomb

In the main crypt, a total of 11 burial niches were torn open and the bodies consumed. Scattered treasure includes five gold rings (180, 120, 100, 75 and 50 gpv respectively), 3 necklaces (300 and 200 gpv, and one broken of agate beads worth 75 gpv), 2 bracelets (gold and jade worth 400 gpv, silver worth 25 gpv), a jeweled dagger (90 gpv), a jade carving of a cat (fist sized and crude, 60 gpv), and some scattered coins (87 sp, 31 gp and 11 pp).

The tomb is occupied by an undead giant spider, slain but not eaten by ghouls, which has some ghoulish traits.

Giant Spider Ghoul (x 1) AC 4, MV 3"*12", HD 4+4, HP 33, ATK 1, Dmg 2d4 + poison + paralysis, SA webs, poison, paralysis, SD immune to sleep, charm, and mind affecting magic, turned as a 7 HD creature, MR Standard, AL CE, Int Low, Size L, XP 480.

Tomb #10 – Bats

by Andrew Hamilton

This tomb was breached by ghouls at the same time as the Spider Tomb. It became the lair of bats, including several giant bats, and this fresh meat attracted the ghouls for a return visit, although the ghouls bit off more than they could chew with the giant bats/mobats, and they were forced to flee.

1) Collapsed Entry

Two ghoul-bats now lair in the darkness of the entry corridor. Ghoul Bats (x 2) AC 8, HD 1, HP 7 each, M 3"/24", ATK 1, Dmg 1d4 + paralysis, SA paralysis, blood drain (1d4 hp/round), SD immune to sleep,

charm and mind affecting magic, turned as a ghoul, MR Standard, AL NE, Int Animal, Size S, XP 87 each.

2) Bat Roost and Trapped Hallway

All the normal bats are now undead, having fallen prey to the ghoul bats' killing frenzies. The hundred or so bats are not dangerous, but are creepy, as they flit about on tattered wings, clearly skeletal and rotting.



A dart trap along one hall way has not been set off, and finding the trigger plate requires digging through a few inches of old bat guano.

3) Guardians' Rest

The burial chamber has four sarcophagi (along the back wall), and two bodies laid to rest on podiums. The two bodies are dressed in full armor and wield weapons, and will have been roused from undead slumber by the sounds of combat with the ghoul-bats. They lie motionless until someone is close enough to be attacked with surprise. As they defend the burial chamber (coffer corpses) the occupants of the four sarcophagi emerge (Sons of Kyuss, ready for combat on the third round). A powerful spell was placed on this chamber to hamper turning, which is done with a -4 penalty to the die roll, and any turning attempt triggers a magical backlash of 2d4 hp damage to the cleric. If a save vs. Spells is failed the cleric will be incapacitated for 1d3 rounds.

Coffer Corpse (x 2) (AC 4 (bronze plate), MV 6", HD 2, Hp 12 each, ATTS 1, Dmg d8 (sword) or d6 (hands), SA strangle, SD hit by magical weapons only, immune to Sleep, Charm and mind-affecting spells, MR standard, AL CE, Int Low, Size M, XP 105 each (81 xp + 2 xp/hp).

Sons of Kyuss (x 4) (AC 10, MV 6", HD 4, Hp 19 each, ATTS 1 +1 brain worm, Dmg 1d8, SA fear 3" diameter, leprosy (25%/blow), brain worm, SD regenerate 2 hp/rd, MR immune to Sleep, Charm & mind-affecting spells, AL CE, Int Low, Size M, XP 341 each (265 xp + 4 xp/hp)

Treasure includes 2 jeweled sword pommels (110 gpv each), a bracelet (gold & agate, 200 gpv), rings (6 rings, gold 35 gpv each), a silver belt & buckle (175 gpv), a bag of platinum discs (14 discs, 15 gpv each), a clerical scroll cast at 10th level (Cure Light Wounds, Detect Evil), and a **Flail +1**). Four potions, each in a container carved from a large tusk (200 gpv each) with **Nystul's Magic Aura** cast on them,

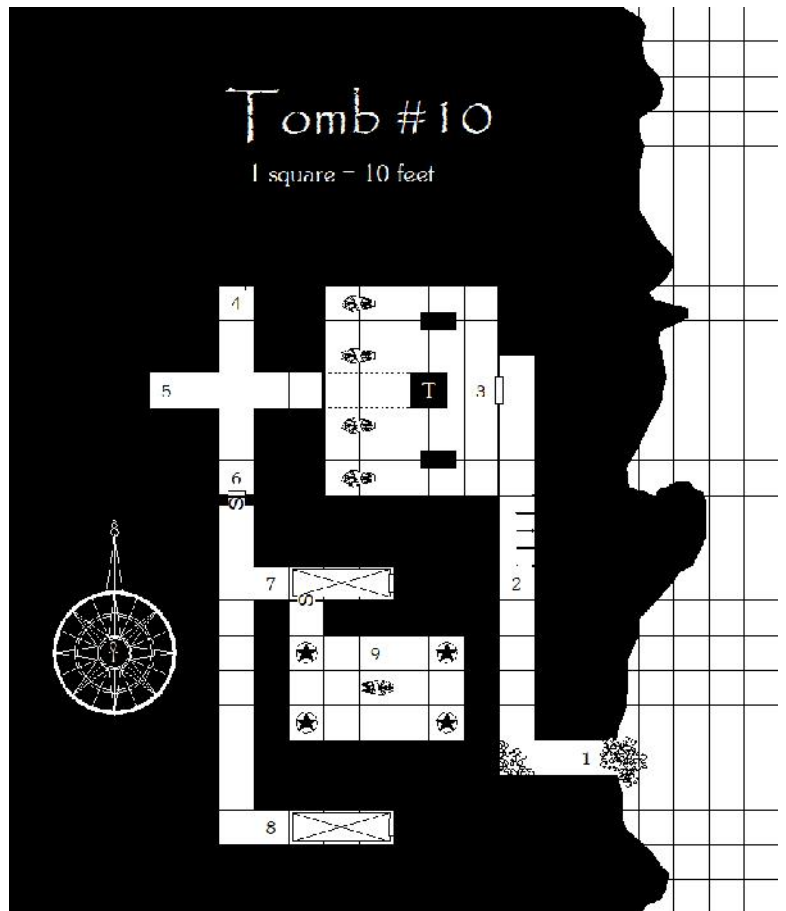

are: Poison, Acid, **Oil of Fiery Burning**, and Poison respectively.

4) False Door

When opened this door triggers an **Evard's Black Tentacles**, affecting 360 square feet of hallway (back to the intersection). Twelve tentacles, each 10' long, erupt from the floor (AC 4, Hp 12).

An individual attacked by a tentacle must save vs. Spells. On a successful save, the victim takes 1d4 hp damage but the tentacle is destroyed. On a failed save, the victim takes 2d4 hp of damage on the 1st round, and then 3d4 hp of damage for the remainder of the spell effect. The **Evard's Black Tentacles** lasts for 12 rounds.

5) False Door

When opened this door triggers a **Web** spell (as per the MU2 spell), filling 80' of corridor with webbing.



One round later a **Fire Trap** spell is activated at the door location, causing 1d4+7 hp of damage.

The **Fire Trap** will ignite the webs, burning 10' per round, and anyone stuck within the webs when the fire reaches them suffers 2d4 hp of damage.

6) False Door & Secret Passage

This false door opens to reveal both a trap and a wall of rough carved stone. The wall conceals a secret door that leads to the rest of the tomb.

The trap is a two part trap; initially it releases a gas with the combined effects of **Stinking Cloud** and **Fog Cloud** spells, the gas spews out for a total of 9 rounds. The initial round fills 2,000 cubic feet (cf) of hallway, each additional round fills another 1,000 cf. On the 2nd round 6 skeletons are released and they immediately attack. The effects of the gas (particularly the obscured vision) will make it possible (even probable) that PCs will harm each other during melee combat.

Skeletons (x 6) (AC 6, MV 15", HD 1, Hp 6 each, ATTS 1, Dmg 1d6, SA none, SD ½ damage from edged & piercing weapons, immune to sleep & charm spells, MR Standard, Int Non, AL N, Size M, XP 24 each

7 and 8) Pit Traps

When the false door at the end of these short hallways is opened, a cover drops away, revealing a 20' deep pit. There are some (inanimate) snake

skeletons in the bottom of the pit, once placed here as guardians to attack tomb robbers.

9) Main Tomb

This tomb is guarded by 4 caryatid columns (each carved to appear as a winged, armored spirit, reminiscent of a Valkrie or similar collector of the dead). They remain inanimate for 3 rounds before attacking (possibly with surprise).

Caryatid Columns (x 4) (AC 5, MV 6", HD 5, Hp 22 each, ATTS 1, Dmg 2d4, SA none, SD ½ damage from normal weapons, no magical bonuses to damage from magical weapons, weapons striking the column break 25% of the time (-5%/"plus"), MR +4 to all saving throws, Int Non, AL N, Size M, XP 360 each.

Inside the sarcophagus is a corpse (inanimate) in funeral dress. Its funeral dress includes a golden torc, a scepter (actually a **Rod of Smiting** with 6 charges), a bracer and a necklace (actually a **Necklace of Strangulation**). There are three scroll tubes (made of silver, worth 35 gp each, and sealed with wax). One contains a clerical scroll (Bless, Aid, Prayer) cast at 7th level. Another is a trap, Explosive Runes, for 6d4+6 hp damage. The third is a treasure map, treated with contact poison (type A, save at +4, no damage on save, 10 hp damage on failed save). The contact poison will transfer to gloves, and might poison the glove wearer later on when they remove and handle their gloves. The destination of the treasure map is up to individual DMs to describe. Alternately, the map can be replaced with a contact poison treated scroll of neutralize poison.

Tomb #11 – Haunted Treasure Hunt

by Bryan Fazekas

DM Background

In a nearby kingdom five soldiers found a map while looting a house. The corporal, Topper, could read a bit and managed to decipher the map which

led to the tomb of a priest, Seisyll, who was laid to rest only three years ago. Thinking that looting a tomb full of gold items would be more rewarding and less hazardous than soldiering, the five deserted as a group and went treasure hunting.



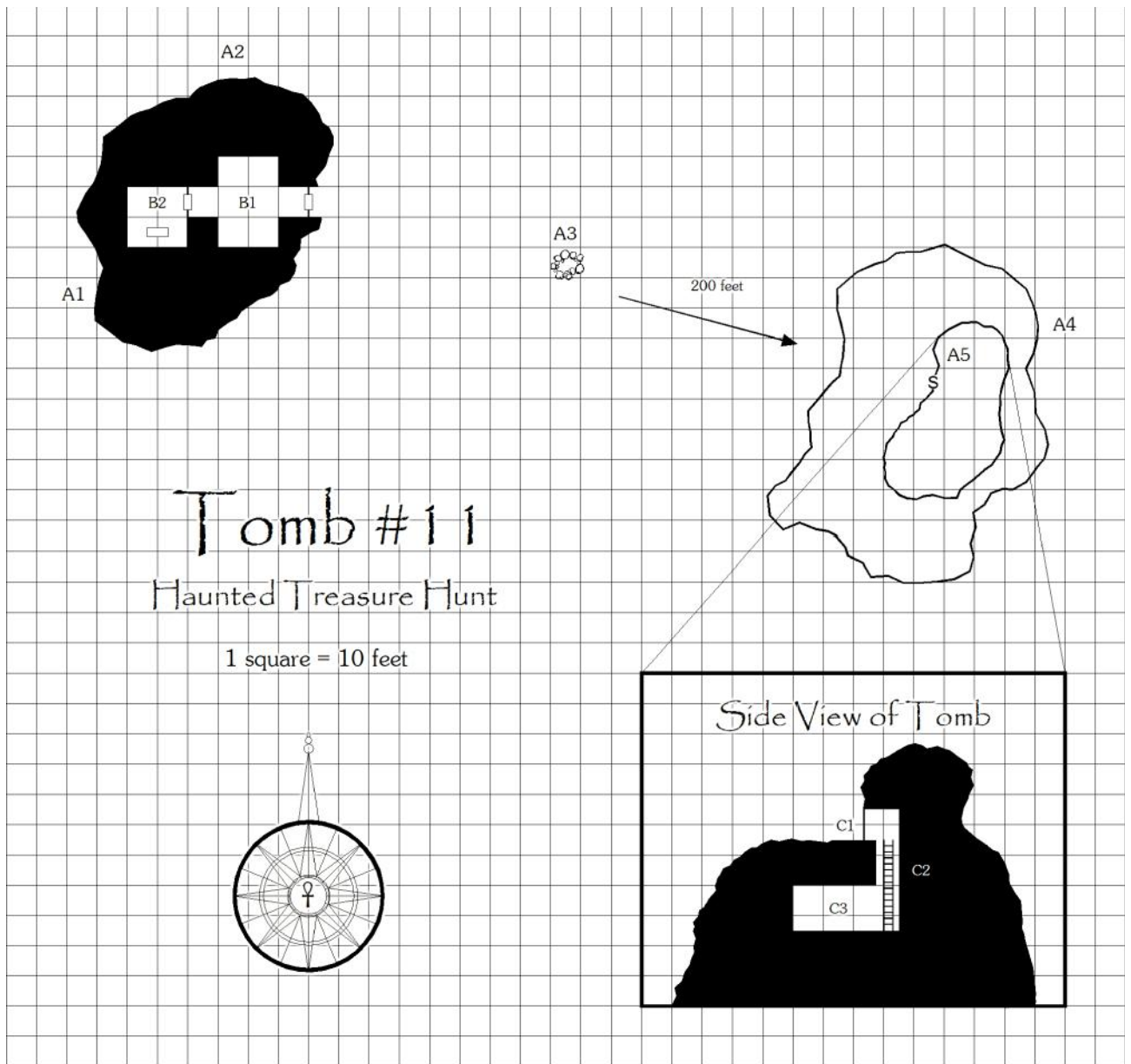

The group found the tomb after a few minor misadventures. Set among tall hardwoods, the tomb is carved in a rock outcropping about 80' across and roughly 60' high. The front of the tomb has been shaped so that it is flat, and the entrance door, which is nearly centered in this face, is of carved stone, well balanced on steel pins. The door weighs in the neighborhood of 1,000 lbs but is well balanced and moves easily.

The group unhappily found that the tomb had been looted. It was bare inside, stripped of everything except dust. They would have left in dejection except that Topper found tiny writing in the corner of the map that stated the treasure was well hidden.

He convinced the others to hunt for a secret panel that hid untold wealth.

Almost immediately a large party of treasure hunters arrived and camped out for three days. The ex-soldiers barely got away before the interlopers arrived, and they watched from hiding as the group pored over the tomb in vain. After they left Topper got the idea of "haunting" the tomb in case anyone else arrived, so they could scare interlopers off. Being a bit brighter than the others Topper invented a few ideas based upon stories his grandfather told him as a child.

Along with the map they acquired a 300' length of spider silk rope, a 1/8" cable that was nearly



impossible to cut and could hold more than the entire group could collectively lift. The back side of the tomb has one spot (A1) where the sheer rock can be climbed quite easily, and the group moved their camp to the top of the tomb as it gives them a defensible position and an excellent viewpoint. Thieves and rangers passing within 10' of the climbing spot will have a chance equal to 10 times their level to notice it, but unless specifically searching others will not.

The ex-soldiers also spotted another large rock outcropping facing the tomb, nearly 300' away. Investigating they found the second rock formation was of similar girth and over 40' tall. Instead of being nearly flat on top this one is mostly flat with a 15' taller outcrop near the back. Similar to the tomb formation this one also hid an area at the back (A4) which provides even unskilled climbers a way up.

The men cut saplings from up in the woods and built a framework on each outcropping, strung the spider silk rope in between, and fashioned a zip line. They also hooked a block and tackle to a tree near each outcrop and setup a line by which materials, including a man, could be pulled up.

This group is typical men at arms, barely skilled with shield and short sword. Each soldier wears decent quality leather armor, and carries an adequate shield and short sword. They are not bad men but are not good either, just a group of young men looking to make the easiest living they can. Their corporal is brighter than average, but none of the five is impressive.

Topper, human M@A, align N, hp 7, Str 12 Int 13
Wis 10 Dex 11 Con 11 Cha 11

Dog, human M@A, align N, hp 5, Str 9 Int 9 Wis 11
Dex 9 Con 12 Cha 10

Kalfort, human M@A, align N, hp 4, Str 12 Int 10
Wis 10 Dex 9 Con 10 Cha 11

Hemp, human M@A, align N, hp 6, Str 12 Int 9 Wis
11 Dex 10 Con 10 Cha 11

Talek, human M@A, align N, hp 5, Str 12 Int 10 Wis
9 Dex 11 Con 9 Cha 11

Tactics, First Night

The ex-soldiers have been here five weeks and have found nothing. They have searched all the walls inside the tomb, the entire outside up as high as they can reach, and the top of the rock outcrop. They have refined their technique for scaring interlopers, twice using it successfully.

The woods are airy enough they can see and possibly hear visitors more than half a mile away. They will hide at the top of the tomb until after dark.

About 100' in front of the tomb is a 4' ring of stones (A3) that treasure hunters have used for a campfire. If the visitors camp here the ex-soldiers will be able to observe them and any attempts they make at security for their camp. Knowledge of the visitor's tactics will be used to adjust the following plans.

When the visitors settle down for the night three of the men will hold the spider silk rope so that it droops to about 20' over the campfire.

Dog, the fleetest among them, will put on an old white robe and climb down the back of the tomb. With the hood pulled up to hide his face he will wait until all but the guards are sleeping and then charge the fire, screaming as he reaches it. He will vault the fire and run for the second outcrop. Ducking around the back he will pull off the robe and quickly climb to the top in the one climbable spot (A4). This will probably shake up the visitors and should wake them all up, breaking their sleep.

What the party sees: a ghostly figure will appear suddenly from the darkness, floating along the ground. It screams a terrible cry of anguish and flies over the fire and disappears into the darkness. This is all optical illusion caused by darkness and surprise. Unless the players immediately give chase they have absolutely no chance of catching Dog.

After they settle again Talek, the lightest, will cover himself in another old white robe. He will slide down the zip line (spider silk cable) with a scream and will fly over the campfire while the remaining three haul the spider silk line taut. He will appear to fly into the trees while in reality he will slide to the second outcrop where Dog will slow him down.



The zip line will be pulled completely taut, hiding it among the leaves. The "haunters" will settle down for the night and get good rest, which the visitors will probably not.

What the party sees: a ghostly figure similar to the first one flies from the tomb entrance with another horrible scream of anguish. It flies 10' above the ground, over the fire like the first one, and then flies vertically into the trees. This is another optical illusion caused by the suddenness and the point of view of the watchers.

Tactics, Next Day

The men picked up a few small bags of a powder that emits a foul stench and a prodigious amount of smoke when burned. They have five bags remaining.

1d8	Direction
1	Forward
2	Forward Right
3	Right
4	Backwards Right
5	Backwards
6	Backwards Left
7	Left
8	Forward Left

If the party leaves their campsite unguarded during the day the men will bury a bag in the cold ashes of the fire when it is likely to catch fire by the next fire built in the ring. The bag will start burning 3d6 turns after the fire is re-started. The smoke initially will form a column 30' high, but the smoke is denser than air and will act like a fountain, dropping to the ground just outside of the ring of stones and spreading 20' in the next round, forming a layer 7' high. The bag will burn for 2d4 rounds with the smoke spreading 10' outward per round, and will continue to spread for 1d4 rounds after the burning is complete. It will clear in 6d6 rounds. The smoke is thick and blue, making vision impossible beyond 5'.

Characters will be disoriented in the smoke, roll 1d8 for each character's initial direction:

Depending upon circumstances the men may use the zip line or the running ghost tactics to further scare or disorient the visitors. Note that these tactics will not be used in daylight.

Tactics, Second Night

The next night Dog will reverse his course, again jumping the fire while screaming. He will run into muddy ground around the north side of the tomb (A2) where he will grab a waiting rope that will be lowered when the men on top of the tomb hear his scream, and he will be pulled straight up. Once into the trees he will pull off the robe and hide in heavy leaves. If the party investigates they will find apparently human tracks which abruptly stop in the middle of an open area.

What the party sees: This is a repeat of the first night's first encounter, but from the other side. Human nature indicates that since two ghosts came from the tomb, attention will be concentrated in that direction. The ghostly figure floating over the ground towards the tomb will be a surprise. If the party reacts immediately and gives chase they will see it fly straight up into the trees, otherwise they will merely find human-like tracks that abruptly stop in the middle of a clearing.

An hour or so later Dog will repeat Talek's wild ride down the zip line.

What the party sees: This repeats the second ghostly encounter of the first night. Note that the zip line is moving more quickly than a man can run so the party will not be able to catch sight of the "ghost" landing on top of the second outcrop.

The DM should improvise other non-magical tactics as the situation dictates.

The first two groups the ex-soldiers encountered left after the second night, to the great amusement of the "haunters".



If Caught?

Topper and his men are not cowards, nor are they especially brave. They aren't anything other than average men with a slightly crafty leader and a good sense of humor. They have no interest in causing harm to interlopers – they simply want to be left alone so they can hunt for treasure. If faced with a fight they don't believe they will win, they will surrender.

Fake Tomb

B1 – Empty Room

This 10' high room is empty except for some blown in leaves and dust, its function not obvious. The stone walls are etched with vines at the 3' and 6' levels. Druids and rangers will not recognize the species represented as they were an engraver's stylized version of generic vines.

B2 – Empty Bier

This room contains a 2' high stone platform that is 7' long by 3' wide. The room is otherwise completely featureless.

The stone platform can be moved, although it weighs more than 1,500 lbs. Characters with strength sufficient to carry 500 lbs collectively can move the platform with 5 rounds of concentrated effort. Beneath the platform is a hole 1' deep, 3' long, and 2' wide. It is empty.

Real Tomb

The cleric who constructed this tomb realized that no tomb goes unlooted. His method to secure his eternal rest was to provide a fake tomb as a diversion and hide his real tomb where it would be difficult to find. The men who carved his real tomb were unknown to those who carved the fake, and he used **Geas** to ensure none would ever reveal his final resting place. **A5** marks the location of the entrance to the real tomb atop the second outcrop.

C1 – Hidden Door

This secret door can be found using normal chances for detection (1 in 6), although a dwarf or gnome

has double this chance to realize there is something here. A latch is covered by a thin layer of rock that was glued in place. It cannot be removed intact but can be broken. Once open the door reveals a 6' wide and 8' tall corridor that goes a mere 6' before reaching a shaft down.

C2 – Ladder Down

The shaft down goes 20' and at that point it opens into a room. Bolted into the wall is a wooden ladder leading down.

C3 – The Tomb

The cleric who worried so much that his eternal slumber would be disturbed? His worry was so strong that he carried it into death with him, and he rose as a wight. Since he ensured that he would not be disturbed, he locked himself into his own vault and has been here for three years since rising. The captivity and realization that he will not rest eternally has unhinged him, and he is quite mad. He clings to a shelf on the north wall and will leap out at the first character to touch his coffin, fighting madly until he or they are destroyed.

Wight AC5, Mv 12", HD 4+3, # Att 1, D/A 1d4 + energy drain, SD silver or magic weapon to hit, Int Average, AL LE, Size M. hp: 27

The room contains a carved wooden coffin worth 1,000 GP if the characters can get it out of the tomb and back to civilization. Six dozen items of tableware – chalices, cups, and the like – line the shelves along the wall. Unfortunately they are all made of copper – they are well made – but are copper, valued at 1GP each. While the cleric could **Geas** his servitors so they could not reveal the location of his tomb, he failed to consider that they might rob him, substituting cheap items in place of his favored items of gold and platinum. However, the servitors did not realize that one of the worthless copper chalices is actually a **Chalice of Potions**.

However, the wight's left boot contains 8 amethysts worth 200 GP each.

Also, the spider silk rope used by the ex-soldiers is very rare – the intelligent species that weaves it is quite rare – and is worth 5 PP per foot.



Loose Ends

Topper and crew are not cowards, but they are not willing to die for nothing. Or maybe not even for something. If pressed they will surrender and will cooperate in good faith, especially if the party demonstrates they are stronger. They may be enlisted in searching other tombs and will actively

help for a share of the treasure. However, except under duress they will not act as trap detectors and can be expected to fight back violently at the worst moment if treated as expendable.

Topper and crew may have a map indicating other tombs in the Valley, or possibly treasure maps to other areas.

Closing Notes

There may be literally a hundred unexplored and unlooted tombs in the Valley of Eternal Rest. The Curse might discourage some tomb robbers, but greed and PC ingenuity has a tendency to overcome almost any obstacle. Of course there may be something (or someone) specific buried here that forces the PCs to deal with the consequences of the Curse for a greater good (assuming they are of heroic bent) or for personal gain (for the more mercenary). Powerful magic, an artifact required to defeat some foe, arcane lore, a heirloom needed to claim hereditary right, etc. Some of the tombs may be veritable death traps, others a simple grave.

When various groups learn their sacred ground has been desecrated and the resting places of their ancestors and faithful violated, they will seek justice. Adventuring parties may find themselves outlaw, with multiple groups cooperating to bring them to before a judge and jury, or send them to the afterlife to face final justice.

DMs should let their imaginations run wild. For those with too much real life commitment draining their creative energy, the article *Tombs & Crypts* by James M. Ward, printed in the *Best of Dragon, Volume I* is a highly useful and highly recommended resource.

New Monsters

Editor's Note

One discussion held early in the genesis of & Magazine regards the format to use for various things. While all staff members are nominally AD&D players ... we all do different flavors of AD&D. Several integrate varying amounts of 2nd Edition AD&D into their game. Another has adopted OSRIC format. At least one pulls material from OD&D and/or BECMI while others are more mainstream AD&D without much outside influence.

How do we select a format that meets everyone's needs? Do we force all material into a mold, possibly adopting a strict AD&D stance on the format of things such as stat blocks?

Our answer is "no".

We agreed to use a modified AD&D format for monster stat blocks. This format includes the original Monster Manual stat block in the same order, and adds as optional the additional fields used in 2nd Edition. Some monsters have these extra fields, some don't.

Our contributors are as eclectic as the staff, and we do our best to preserve the flavor of all submissions.

If we publish an OD&D article? We will probably leave it in that format as it makes sense to do so. The staff and readers of & Magazine are an eclectic bunch and we, the staff, are working to keep everyone on common ground.



Animated Weapon

Frequency: Rare
No. Appearing: varies (typically d4+4 or more)
Armor Class: 4
Move: 12"
Hit Dice: 3 (24 hp)
% in Lair: 100%
Treasure Type: n/a
No. of Attacks: 3/2
Damage/Attack: by weapon type +1
Special Attacks: attack as a 7th level fighter
Special Defences: limited spell immunity
Magic Resistance: Saves as "metal hard"
Intelligence: n/a
Alignment: N
Size: S
Level/X.P. Value: 177 xp (Animated Weapon)

By Andrew Hamilton

These magical constructs, typically in the form of a sword, were a common form of guardian in the days prior to The Shattering. Magic-users and clerics both had the capability of animating weapons, although the spells and rituals once used to do so appear to be lost.

Only melee weapons may be animated (i.e. no bows, crossbows, slings, etc.). Animated weapons have a limited form of flight, and whirl or dance through the air to attack. They are unable to rise more than 12' off of the ground however, although they are able to "fly" above water, mud or other less than solid surface without penalty.

Animated Weapons are treated as +1 for determination of what they can strike, and cause the same base damage as a normal weapon of their type, with a +1 damage bonus. Once their hit points have been depleted, the animated weapon will be ruined, and fall to the ground suddenly corroding, splintering, warping, or showing other signs of damage.

Being an animated construct rather than a living being, animated weapons are immune to Sleep, Charm, ESP, or spells that only affect living things (e.g. **Magic Missile**). Furthermore, animated

weapons do not save using the "monster" saving throw table, they save as "metal hard" under the object saving throw table.

Greater Animated Weapons

There are rumors of animated magical weapons, the result is a more powerful and deadly construct. The "greater animated weapon" gains the to hit and damage bonuses of the weapon, the AC is reduced by the "plus" of the weapon, the weapon attacks twice per melee round, and the weapon gains additional hit points (equal to 3x the "plus"). The animated weapon saves at a bonus equal to the "plus" of the weapon. The downside to using a magical weapon in the creation of an animated weapon is that upon the depletion of its hit points, it is likely to be destroyed and useless in the same manner as the standard **Animated Weapon**, with only a 1% chance per "plus" of surviving.

Cave Sundew

Frequency: Uncommon
No. Appearing: 1 (typically)
Armor Class: 8 (body); 5 (tentacles)
Move: 1"
Hit Dice: Body: 6; each tentacle: 2
% in Lair: 90%
Treasure Type: J, K, L, M
No. of Attacks: 1-4, depending on how many tentacles are free
Damage per Attack: 1d10 from each tentacle, plus adhesive
Special Attacks: *Adhesive*: Any creature struck by a tentacle must save vs. Paralyzation or be stuck to the tentacle's fibrous end. *Sensitive to vibrations*: Can sense vibrations of creatures as small as a mouse walking/crawling below it. *Surprise*: Any potential victim not actively scanning the area above the creature's puddle can be surprised on 1-3.
Special Defenses: None
Magic Resistance: None
Intelligence: Animal
Alignment: Neutral
Size: L
Level/x.p. Value: 1,800 + 14 per hit point
Climate: Subterranean



Organization: None
 Activity: Solitary/usually stationary predator
 Diet: Carnivorous
 Morale: Never checks morale
 Modifiers: None

by *Jeremy Dow*

The cave sundew is a strange but horrifying hybrid of fungus and the carnivorous sundew plant. Unlike plants, however, this creature has a large mouth (3' diameter) with sharp teeth. A meat-eater with a huge, amorphous body (roughly ten feet in diameter) and four 30-foot tentacles, this creature is truly a fearful menace to the underworld. It lacks eyes, and it relies on its sensitivity to vibrations to detect approaching victims. Its body and tentacles secrete a highly adhesive goo, which it uses to trap and grab prey.

The cave sundew moves very slowly—only ten feet per round—by inching forward much like an inchworm. What it lacks in speed, however, it makes up for by laying traps for the unsuspecting. Typically it will attach itself to a wall some thirty feet above the floor of a cave or cavernous passageway. After secreting a puddle of its adhesive substance on the ground directly below its position, it lies in wait for unwary creatures. A constant dripping of the adhesive goo keeps the viscous puddle from drying out. Once a victim moves onto the adhesive, it will be held fast for a number of rounds depending on its strength: A victim with a strength of 18 can break free in one round, a victim with a strength of 17 in two rounds; and so on. While the victim is struggling to break free from the adhesive, however, the creature will attempt to surprise its prey (1–3 chance) by quickly attacking with its tentacles at +2 (as if attacking from the rear). If it successfully grabs a victim, it will rapidly carry its prey upward for devouring.

The adhesive substance on the Cave Sundew's tentacles makes it unnecessary to wrap them around prey as an octopus does. Any creature successfully struck by a tentacle must save vs. Paralyzation or be stuck to the appendage for a number of rounds depending on its strength (see above). If the victim is alone and unaided, it will be

devoured immediately. If there are allies who attack, however, the creature will attach its victim to the adhesive on its body until a later time when it can be devoured. It takes one full round to transfer a victim from a tentacle to its body.

A seized victim may be able to make melee attacks while held. Use the following chart to determine which part of the victim's body is adhered to the tentacle:

1d8	Body part seized
1	face
2–3	arm (d4: 1–2 = left, 3–4 = right)
4–5	torso
6–7	leg (d4: 1–2 = left, 3–4 = right)
8	back of head

If an attack is possible at all, it suffers a –2 penalty. DMs should use judgment and common sense, however, to determine whether such attacks are even possible. Fighting back will be difficult for a victim grabbed by a leg and dangling upside down in midair (–4 to hit and damage). A victim grabbed by the face attacks at –4, as though attacking an invisible opponent. Of course, if a melee weapon was not drawn when seized, fighting back is futile. The Cave Sundew typically has little treasure other than what small items happen to fall from victims down into the adhesive puddle (everything else is consumed). Even the coins and gems

Clockwork Anubis Guardian

Frequency: Very rare
 No. Encountered: 2-6
 Size: Large
 Move: 12"
 Armor Class: 0
 Hit Dice: 7+4
 Attacks: 1
 Damage: 2d8
 Special Attacks: *Nil*
 Special Defenses: *Nil*
 Magic Resistance: Standard



Lair Probability: 100%
Intelligence: Non
Alignment: Neutral
Size: L
Level/x.p. Value: 725 + 10 per hit point
Climate: any
Organization: None
Activity: animated construct
Diet: None
Morale: Never checks morale
Modifiers: None

by Patrick Fazekas

The Clockwork Anubis Guardians are 10' tall statues that are carved in the semblance of Anubis, a Jackal-Headed Egyptian god associated with the afterlife and mummification. The Anubis Guardians are black marble, with gold detailed kilts and armor pieces. They have fig-sized topaz gems for eyes and have empty, haunting stares even when inactivated.

Clockwork Anubis Guardians are exactly what they sound like: mechanical. They are powered by a spark of magic which keeps them working and their thoughts moving. The Guardians have low, simple intelligence, but can recognize dangers and challenges presented to them. What passes for their brains can process basic thoughts and words. They are neutral, and will not treat a certain alignment creatures/players any differently than others.

As automatons, Clockwork Anubis Guardians are immune to spells that affect living creatures including charm person or monster, hold person, sleep, cause wounds, vampiric touch, etc.

The Anubis Guardians are fairly quick, moving as quickly as an unarmored man (12"). They attack with large brass maces. When activated, Clockwork Anubis Guardians will zero in on and attack the threats presented to them.

Note: The Clockwork Anubis Guardians are mechanical statues powered by a spark of magic. They will not show up under Detect Magic or Detect Trap spells.

Ghoul Bat

Frequency: Very Rare
No. Appearing: 2d12

Armor Class: 8
Move: 3"/24"
Hit Dice: 1
% in Lair: 100% (day), 0% night
Treasure Type: nil
No. of Attacks: 1
Damage/Attack: 1d4
Special Attacks: paralysis
Special Defences: turned as a ghoul
Magic Resistance: immune to sleep, charm, and mind affecting magics
Intelligence: Animal
Alignment: Neutral Evil (attack all living creatures)
Size: S
Level/X.P. Value: II/49 xp + 1 xp/hp
Climate: Any
Organization: Undead, flock
Activity: Undead
Diet: Living creatures
Morale: ??

by Andrew Hamilton

While the undead condition of a ghoul is most commonly associated with humans and humanoids, there are cases where other creatures slain but not consumed by a ghoul rise as a ghoul. The ghoul bat is one example of such an undead creature. These creatures seek the refuge of caves, attics, tree hollows and similar dark and secluded places during the day. At night the bats emerge as a group and fly in search of prey, swarming any warm-blooded prey they encounter (livestock, wild animals, or humanoids).

Any creature paralyzed (the normal result if a creature is swarmed by a dozen ghoul bats), the bats will eat the creature then and there unless they are attacked by another creature, in which case they will descend en masse upon the intruders.

Ghoul bats collect no treasure, and lack the evil cunning of a humanoid ghoul, driven only by an insatiable need to feed.

Author's note – these are modified Giant Bats, from the *Fiend Folio*, taking inspiration from Len Lakofka's ghoul striges, published in *L1 The Secret of Bone Hill*. The concept behind the ghoul bats was extended to the giant ghoul spider as well.



Ghoul Spider, Giant

Frequency: Very Rare
No. Appearing: 1d4
Armor Class: 4
Move: 3"*12"
Hit Dice: 4+4
% in Lair: 100%
Treasure Type: C (reduce all amounts by ½)
No. of Attacks: 1
Damage/Attack: 2d4
Special Attacks: webs, poison & paralysis
Special Defences: turned as 7 HD creature,
Magic Resistance: immune to sleep, charm, and
mind affecting magics
Intelligence: Low
Alignment: Chaotic Evil
Size: L
Level/X.P. Value: V/320 xp + 5 xp/hp
Climate: Any
Organization: Undead, solitary hunter
Activity: Undead
Diet: Living creatures
Morale: ??

by Andrew Hamilton

While the undead condition of a ghoulish is most commonly associated with humans and humanoids, there are cases where other creatures slain but not consumed by a ghoulish rise as a ghoulish. The giant ghoulish spider is one example of such an undead creature; frightening as it retains its evil intelligence, lethal bite and web-spinning abilities, and gains the paralytic touch of the ghoulish. Thus, prey bitten by a giant ghoulish spider must save vs. poison or die (no bonus) and save versus paralysis or be paralyzed for 2d6 turns. Elves are immune to the paralytic effect of the bite.

A ghoulish spider will attempt to strike from ambush, either dropping from above or waiting until prey is trapped in their webs. They may collect treasure (often to be used as a lure), but often change lairs seeking more prey. In these cases they abandon their treasure.

For details on the giant spider's webs, refer to the Spider, Giant entry in the *Monster Manual*.

Guardians of the Dead

Frequency: Very Rare
No. Appearing: 4, 8 or 12
Armor Class: 2
Move: 18"
Hit Dice: 3+3 (27 hps)
% in Lair: see below
Treasure Type: nil
No. of Attacks: 1
Damage/Attack: 1d6+1
Special Attacks: strike as 6 HD creature, +3 to initiative
Special Defences: ½ damage from cutting & piercing weapons, regeneration (1 hp/rd), reformation, limited spell immunities
Magic Resistance: Limited spell immunity, save as 6th level Fighter
Intelligence: Average
Alignment: Neutral
Size: M
Level/X.P. Value: V/448 xp
Climate: Any
Organization: Divine Construct
Activity: Divine Construct
Diet: none
Morale: Never checks morale

by Andrew Hamilton

Although they appear to be undead, the Guardians of the Dead are actually divine minions, created by and serving an ancient and forgotten God of the Dead. Guardians of the Dead appear as a quartet, a group of eight or a group of twelve (the number 4 is a sacred number to the God of the Dead).

The Guardians of the Dead appear as simple skeletons, wearing battered, corroded and tarnished bronze armor (including bronze helmets and shields), and they wield bronze short swords in a similar condition. The bronze is magically hard, and immune to further corrosion. The Guardians cannot be turned, and even if destroyed, the power of the God of the Dead causes them to reform each night. These creatures will also pursue any tomb robbers, unerringly and relentlessly honing in on them (unless foiled by non-detection magic). The



Guardians must be destroyed 9 times to finally defeat pursuit.

The Guardians of the Dead are not evil, and they are interested only in protecting the remains of those who have been interred in the location that they have been set to watch over. Travelers or visitors to a burial site may witness Guardians patrolling the area, but the Guardians will not approach simple travelers, those visiting to pay homage to the dead or worship at a shrine, or prepare a new burial niche or tomb. However, should someone defile a tomb, the Guardians will attack, fighting intelligently and without fear or quarter.

Empowered by a deity, the Guardians have a range of powers. Their skeletal form provides a resistance to edged and piercing weapons similar to that of normal skeletons (½ damage from slashing & piercing weapons). They also share a number of spell immunities with undead, including immunity to sleep, charm, cold, poison or fear effects. The divine spark that powers the Guardians also provides them great durability (maximum hit points per die and regeneration of all damage at a rate of 1 hp/round) and quickness (including a +3 bonus to initiative). They are also able to harm any creature (even those normally harmed by +4 or better weapons), and attack as a 6 HD creature.

Guardians of the Dead collect no treasure, and are only interested in protecting the remains of burial possessions of those under their care. Should tomb robbers fall before Guardians of the Dead, the Guardians will recover any stolen items, but leave all else to lie where it falls. They do not communicate (either through speech or ESP), but can gesture, although this is rare.

NOTE: These statistics represent Guardians of the Dead empowered by a forgotten god that lacks worshippers. On realms where the God of the Dead is actively worshipped, the Guardians of the Dead are more powerful. In a realm where the God of the Dead is a lesser god, the Guardians are AC 1, HD 4+4, 36 hps, attack and save as 8 HD, and strike for 1d8+1 hit points of damage. In a realm where the God of the Dead is a greater god, the Guardians are AC 0, HD 5+5, 45 hps, attack and save as 10 HD, and strike for 1d10+1 hit points of damage.

Worm, Little Green

Frequency: Very Rare
No. Appearing: 1,000d10
Armor Class: 9
Move: 1"
Hit Dice: 1 hp
% in Lair: 100%
Treasure Type: incidental
No. of Attacks: 1
Damage per Attack: 1 hp
Special Attacks: burrowing into flesh
Special Defenses: nil
Magic Resistance: standard
Intelligence: Non-
Alignment: Neutral
Size: Small (1-2' long)
Level/x.p. Value: I / 1 xp
Climate: Temperate
Organization: Swarm
Activity: Any (special)
Diet: Carnivore
Morale: Fearless (20)

by Varl

Little green worms are the spawn of Mother Worm, a monstrous, massive green worm with orifices all over its body. Little green worms are spewed out of Mother as a biological reflex as well as a defensive action. Little green worms defend the Mother worm through some unknown physiological connection.

Combat

Little green worms do not attack of their own accord. They are a response trigger or threat reply made against the Mother. If either condition is met, they locate, crawl and swarm over the targeted creature in mass. They are able to burrow into the flesh of living or unliving creatures, slowly devouring them from the inside out. The nutrients gained are then transferred back to the Mother via entry into Mother's numerous mouth orifices.

Habitat/Society

Little green worms prefer cold, dark, dank caverns and dungeons. Sunlight kills them quickly by drying out their skin, and withering them away into



dry husks. They congregate together in mass, typically surrounding their creator-Mother worms as a means of defense and food gathering. Most little green worms will not venture further than 100 yards or so from the creator-Mother. The physiological link between the worms and the Mother prevents it, even if the cavern or area is larger. If transition to a new area outdoors is needed, little green worms will merge back inside of their Mother worms first.

Upon death of Mother, the little green worms lose the biological link they have with their Mother, and become docile and dormant for 1 day. After that day, one specific worm amongst the thousands available begins to feed upon its kin, gorging itself relentless and endlessly, until it eventually grows into another Mother. This process takes a month. Halfway through its development, it starts to spawn worms of its own, thus adding to the greatly depleted worm count and helping to feed itself at the same time.

Ecology

Little green worms serve little use to the ecology of an area other than they do tend to clean up carcasses or other detritus within their range as "commanded" by their Mother worms. They are fearless scavengers, not hesitating to attack any foe they deem threatening or as a potential food source as deemed by Mother, even undead.

Worm, Mother

Frequency: Very rare

No. Encountered: 1 (+1d6x1000 little green worms)

Move: 1"

Armor Class: 10

Hit Dice: 6

Attacks: 1 or 1

Damage: 2d8 (acid) or worms

Special Attacks: *Spew worms, spew acid*

Special Defenses: *Nil*

Magic Resistance: Standard

Lair Probability: 100%

Intelligence: Non

Alignment: Neutral

Size: L

Level/x.p. Value: 525 + 6 per hit point

Climate: subterranean

Organization: None

Activity:

Diet:

Morale: Standard

Modifiers: None

by Varl

Mother worm is a huge green worm thought to have been created by some foul magic or spawned as an offshoot or castoff abomination from a Deepspawn. Whatever their origins, Mother worms are considered a plague creature by some; others consider them a natural ecosystem cleaner.

Combat

Mother worms do not fight directly against enemies. They spews out thousands of little green worms as a defense measure and a feeding mechanism. These little green worms she spews out swarm and are capable of taking down much larger prey. If the Mother is approached, the little green worms immediately attack, sensing a threat to the mother, and attempt to climb onto and burrow into characters as above. If the Mother is attacked, she defends herself by spewing streams of little green worms at the characters. She can also shoot a stream of acid from any orifice 5 times a day out to a range of 30 feet. She shoots these acid streams when under direct attack, but otherwise, shoots forth worms in defense. Characters struck by the acid stream must save vs. breath weapon or suffer 2d8 points of corrosive damage, and metal armor and equipment must also make item saves to avoid item destruction per hit. Mother is particularly vulnerable to fire, suffering double damage if she fails to save. If killed, Mother worms explode into a massive shower of goo and meat chunks (no damage), forcing characters to save vs. poison at -1 or spend the next round vomiting from the stench and sheer horridness of her death.



Habitat/Society

Mother worms prefer the same habitat as the little green worms they release. Mother worms prefer cold, dark, dank caverns and dungeons. Sunlight kills them just as quickly as little green worms by drying out their skin, and withering them away into dry husks. If transition to a new area outdoors is needed, Mother worms travel only at night when it's cool and dark. If killed, the masses of little green worms left behind begin the process of creating their new Mother worm, a process which involves one specific worm devouring and gorging itself upon its kin and any other food it can find. After a month of feeding, the new Mother now huge in size,

establishes its physiological connection with the remaining worms, as well as beginning to spew out new little green worms to replenish the greatly depleted worms.

Ecology

Mother worms serve little use to the ecology of an area other than they do tend to clean up carcasses or other detritus within their range. They are fearless scavengers, not hesitating to attack any foe they deem threatening or as a potential food source, even undead.

New Magic Items

Chalice of Potions

This magical chalice appears well made, but of cheap copper not more valuable metals, although it detects as magical. The original was produced by a wizard famous for the efficacy of his potions. When used in the fabrication of potions the Chalice adds +3 or +15% to all saving throws or chance of success.

Further, when potions are drunk from the Chalice the imbiber gains +3 on any applicable saving throw, or -3 if the imbiber is trying to fail the save. If multiple potions are drunk and at least one is drunk from the Chalice, the imbiber receives +15% on the roll on the Potion Miscibility Table (AD&D DMG, page 119).

XP: 1,500 Value: 15,000 GP

by Bryan Fazekas

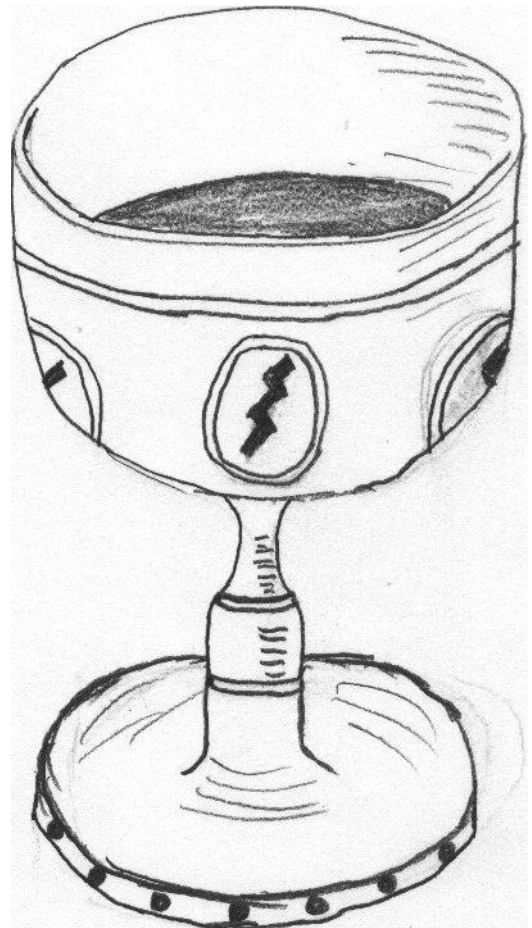

Stay tuned for more publications from the & Publishing Group!

This adventure module is compatible with
Advanced Dungeons & Dragons (AD&D)™
Advanced Dungeons & Dragons 2nd Edition (AD&D 2E)™,
and open gaming license versions of these games
including OSRIC™.

With game master ingenuity and translation,
this adventure is also compatible with the original
Dungeons & Dragons™, including the *Holmes*,
Moldvay/Cook, *Mentzer/BECMI/RC*, and
open gaming license versions of these games.

Dungeons & Dragons™, *Advanced Dungeons & Dragons*™, *D&D*™ and *AD&D*™ are owned by Wizards of the Coast and their use here is not intended as a challenge to their ownership of that copyright. All materials are used here without permission.

Nothing in this publication constitutes official rules additions or changes to the *AD&D*™ game. Use is at the discretion of the game master and the players of individual games.

The **& Publishing Group** publishes fantasy role playing game articles, fiction, columns, adventures, and related materials primarily focused on the *Advanced Dungeons & Dragons*™ game. We also publish for *Advanced Dungeons & Dragons 2nd edition*™ and all variants of the original *Dungeons & Dragons*™, plus similar open source game systems including *OSRIC*™, *Labyrinth Lord*™, etc.

Article submissions must be in RTF, Microsoft Word, or OpenOffice format. Artistic submissions must be in a common format including JPG, PNG, TIF, and GIF. Other formats may be acceptable, please inquire before submitting. No submissions in non-digital format will be accepted excepting some extreme mitigating circumstances.

Please spell check and proof articles before submitting, and please submit only articles that are completed. Drafts and outlines will be rejected. Please note that & will copy edit articles for content or length at staff discretion, although we make every effort to preserve the author's style. Authors will be required to sign a release giving & permission to publish their works.

Please no articles or art of pornographic, graphic, or distasteful nature. & reserves the right to reject any material deemed objectionable.

See the <http://www.and-mag.com/> for detailed submission guidelines.