



**Twilight:  
2000**

# LAST BATTLE™

*Tim Ryan*



Complete Man-to-Man,  
Tank-to-Tank Boardgame  
for Battles in World War III

**GDW**

Easy-to-Learn, Fun-to-Play  
Combat Resolution System  
for Twilight: 2000

# LAST BATTLE™ Rules Book

Twilight:  
2000

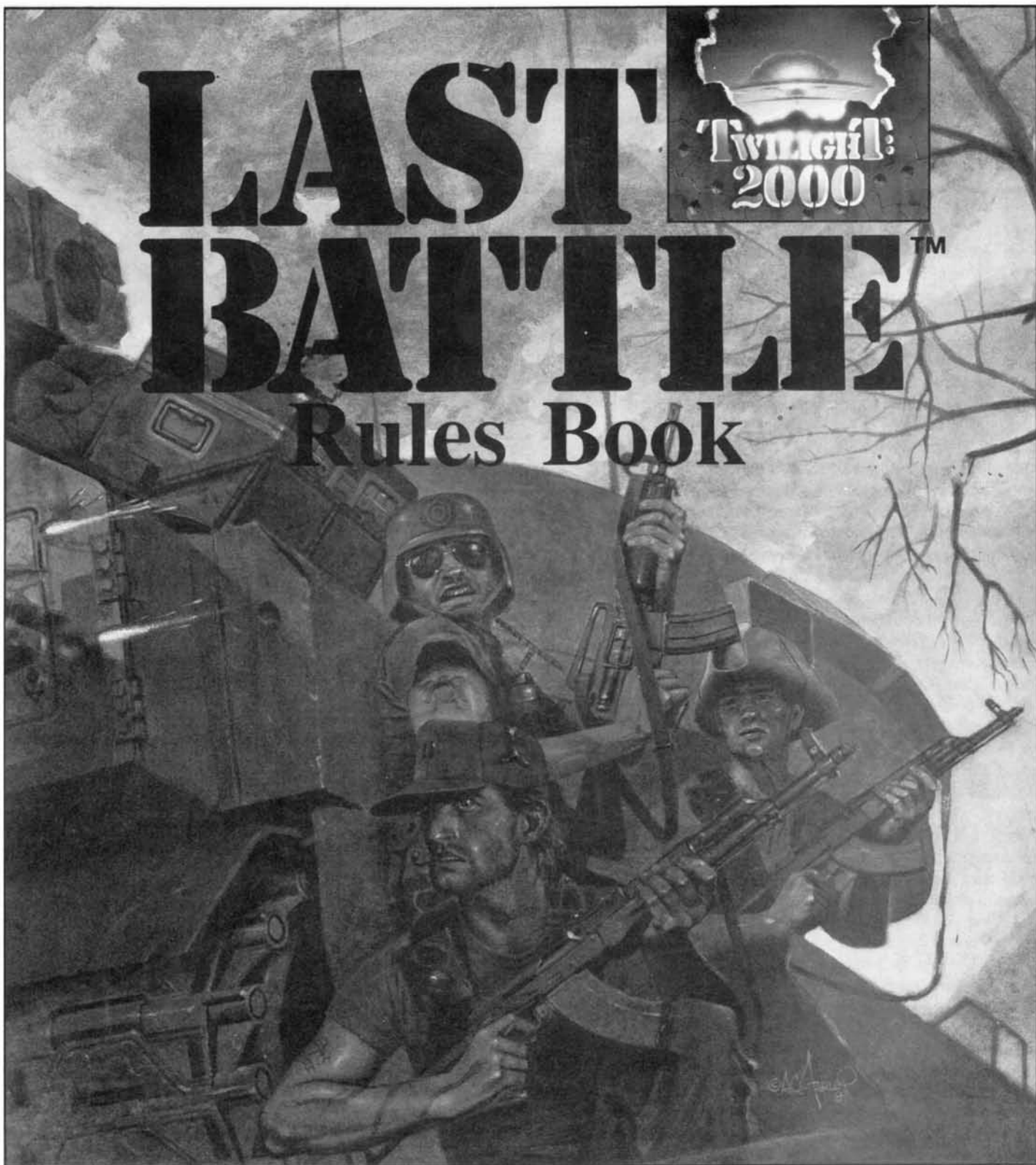

Since 1973

**GDW**

**FIRST  
BATTLE**

series game from GDW

# Last Battle

World War Three has begun.

Two world wars and countless skirmishes in the 20th century could not placate man's seeming desire for warfare. Once again, every nation of Earth has been drawn into a global contestation for land, resources, and power. What is different this time is the sophisticated technology of the tanks, aircraft, personal weapons, and particularly the nuclear missiles.

All-out global nuclear warfare would destroy the planet, and every nation knew this, but none prevented the limited nuclear warfare. Cities have been leveled; entire armies have been destroyed; governments have fallen. What remains are small groups of soldiers—platoons and fireteams—separated from their chain of command and supply lines, who rely on training, instincts, and what remains of their weapons to fight the last battle.

**Last Battle** is two distinct games:

- A system for resolving combat in the role-playing game **Twilight: 2000**.
- A stand-alone boardgame.

As a **Twilight: 2000** boardgame, **Last Battle** quickens vehicle and troop combat resolution while preserving the detail and flavor which has made the role-playing game so popular. As a complete, stand-alone boardgame, **Last Battle** is the ultimate simulation of immediate post-holocaust warfare.

## GAME COMPONENTS

The following is a list of the components in **Last Battle**.

**Maps:** **Last Battle's** game maps are stylized maps of real terrain with a hexagonal grid laid over them. This grid regularizes the distances represented on the maps and provides cells or hexes in which the counters are placed.

**Counters:** Some counters in **Last Battle** represent a specific force; these are called *units*. The units vary greatly, from a one-man machinegunner to a four-man fireteam, a howitzer, tank, or helicopter. Other **Last Battle** counters do not represent military units; these are referred to as *markers*. The illustrations located to the right show the various units which will be used in **Last Battle**. The game markers are illustrated in

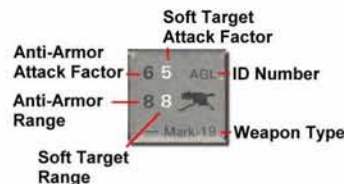
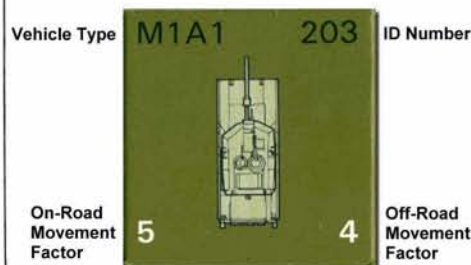
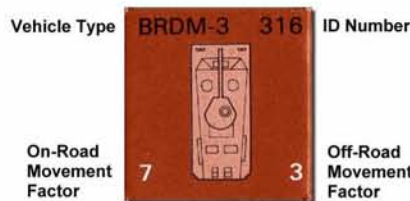
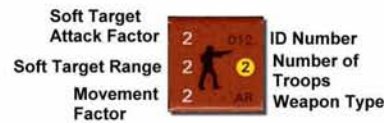

the sections of this text which govern their use.

The infantry unit counters come in sets, which are identified by a weapon abbreviation in the bottom right-hand corner of the counters. Each counter also has a separate ID number. Infantry counters have a side view illustration of a soldier. To the right of the illustration is a yellow circle with a number inside it. This number is how many soldiers the counter represents: a 1 indicates a single soldier; a 4 indicates a four-man team. Each point of damage which an infantry unit takes results in the loss of one man from the unit.

**Rules:** This rules book presents all the information needed to play **Last Battle**. All the game charts are presented together in the back of the book to aid play.

**Vehicle Cards:** Any self-propelled vehicle which requires a crew onboard has a vehicle card. The vehicle cards present detailed information about each vehicle in **Last Battle** (tanks, APCs, helicopters, trucks, etc.). Each also includes an illustration of the vehicle, special charts, and a place to put the counters which represent the vehicle's crew and passengers (troops).

The large illustration of the vehicle inside the hex is used to determine the vehicle's armor value on the side that has been hit. The inside of each hexside lists an armor value. The M1, for example, has an armor value of 60 if hit from the front or front flanks, an armor value of 8 if hit from the rear or rear flanks, an armor value of 56 if hit in the turret, and an armor value of 2 if hit in the treads.

**Scenarios:** A separate book of scenarios presents all the information needed to play different battles.

**Dice:** Many decisions in the rules are resolved by rolling dice. When the rules say "roll a die," the player rolls one six-sided die.

**Learning the Rules:** If you are fairly new to wargaming, the best way to gain familiarity with the rules of **Last Battle** is to read through the basic rules first, then play the first scenario in the *Scenarios Book*.

If you are an old hand at wargaming, read through the entire rules book and then pick a scenario that interests you.

# Basic Rules: Infantry

The basic rules presented in this chapter apply to all **Last Battle** scenarios.

## URNS

Each **Last Battle** turn represents 30 seconds; many scenarios run for a specific number of turns. Each turn consists of a player-turn for each side. When both players have completed their player-turns, the game-turn is over, and the next game-turn begins.

Each player-turn brings an opportunity for the player to move his units and to attack enemy units. During the player-turn, activity takes place in phases.

## GAME-TURN

Player-Turn 1

Player-Turn 2

## PHASES IN A PLAYER-TURN

**A. Movement Phase:** The player moves his units.

**B. Reaction Fire Phase:** The enemy player gets reaction fire.

**C. Attack Phase:** The player can fire any units which did not move in the Movement Phase.

In the Movement Phase, the player selects which of his units should move and then moves them. A unit which moves in the Movement Phase may not fire in the Attack Phase. The only exception is a unit armed with a submachinegun (SMG) or pistol (PST); SMG and PST units may move in the Movement Phase *and* fire in the Attack Phase.

In the Reaction Fire Phase, enemy units may fire once.

**Initiative:** Each game scenario indicates which player is the attacker and which player is the defender. The attacker in each scenario has the initiative. While holding the initiative, the player decides at the start of each game-turn whether to take his player-turn first or second. For example, he may take his player-turn second in one game-turn and first in the next game-turn (thus having two friendly player-turns in a row without an intervening enemy player-turn).

## MOVEMENT

Units may move during the Movement Phase of the friendly player-turn. Each unit has a movement factor (MF). This movement factor is the number of movement points (MPs) it may spend in a turn. Unused movement points do not carry over to the next turn. Each map hex has a cost to enter expressed in MPs.

Movement points are spent as a unit moves through the terrain on the map. When a unit has spent all its MPs, it must stop and cannot move any farther in that turn.

**Terrain Costs:** The terrain in map hexes costs MPs to enter. For example, clear terrain hexes cost 1 MP to enter; woods terrain hexes cost 2 MPs to enter. A unit with 4 MPs could move through four clear terrain hexes in a row, or two woods hexes in a row, before having to stop. Alternatively, the unit could move through one woods hex and two clear terrain hexes.

The Terrain Effects Chart (on the back page) shows the types of terrain on the maps, their MP cost to enter, and their effects on combat.

There may be more than one type of terrain in a hex; in such cases, the cost to enter the hex is the cost of the most expensive terrain in the hex. For example, a hex might contain clear terrain and woods terrain. The cost to enter the hex would be 2 MPs because woods terrain costs more to enter than clear terrain. Likewise, there may be more than one elevation in a hex; a unit is always assumed to be at the higher elevation. Infantry may enter a hex with an elevation which is as much as two levels higher or lower than that of their present hex.

When moving along a road or trail, units ignore all other terrain in the hex (e.g., an infantry unit moving along a road that runs through forest may move 2 hexes along the road). But for combat purposes, the unit is considered to be in the cover of the woods (e.g., a unit on the road mentioned above is both on the road and in the forest).

When initially entering a road or trail hex from a non-road or trail hex, the cost to enter the road or trail hex is the cost of the other terrain in the hex. For example, a road hex in forest terrain costs 2 MP to enter.

## TERRAIN TYPES

Type	Movement Cost
Clear	1
Woods	2
Road	1*
Trail	**
River	Impassable***
Town	1
Rubble	2
Bridge	1

\*Vehicles have separate onroad movement factors.

\*\*Infantry pay 1 MP. HMMWVs and FAVs use their onroad MF, and UAZ-469s use their offroad MF; both pay 1 MP. All other vehicles pay the cost of the terrain in the hex.

\*\*\*River hexes may not be entered except at bridge or by amphibious vehicle.

**Terrain Effects:** When attacking units in town, rubble, and woods hexes, subtract 1 from the number needed to hit. For example, a unit firing at Medium range normally needs to roll a 2 or less to hit, but if the enemy is in a forest hex, the firing unit must roll a 1.

**Stacking:** Any number of infantry counters may occupy the same hex. It is possible for infantry units from both sides to occupy the same hex at the end of a Movement Phase; in this case, the attack range would be zero (Close range for all weapons except grenades and pistols).

**Making Change:** Troop counters come in increments of men, ranging from one to six. A single counter may be replaced by several counters, and several counters may be combined into one, provided this does not change the weapon with which the troops are equipped and the number of men in the hex is not altered. This may be done at any time during the turn, but is usually done to either take losses or split a unit up to move into different hexes.

**Minimum Movement:** Any unit (except an immobilized vehicle, destroyed unit, or dummy) can always move one hex, even if the MP cost to enter the hex is greater than the unit's movement factor. These units may also change their facing in a hex at no cost in MPs (see Facing in "Advanced Rules: Vehicles").

## ATTACKS

In the Attack Phase, the moving player may attack enemy units. Each unit may fire in any direction, and may divide its attack strength to fire at several enemy units. Attacks are resolved in two steps: hit determination and casualty determination. The printed range on the counter affects hit determination, while the printed attack strength affects casualties.

## HIT DETERMINATION

The firing player indicates the target unit for each of his units which are firing, and the attack by each firing unit is resolved separately.

An infantry unit's chance of successfully attacking an enemy unit is based on the distance to the enemy and the infantry unit's attack range (printed on the counter).

**Close Range:** If a unit is attacking at half its printed range or less, the attack is considered Close range; the attacker needs to roll a 4 or less on one die to hit.

**Medium Range:** If a unit is attacking at between Close range and its printed range factor, or at its printed range, the attack is considered Medium range; the attacker must roll a 2 or less on one die to hit.

**Long Range:** If a unit is attacking at between Medium range and twice its printed range, the attack is considered Long range; the attacker must roll a 1 on one die.

**Extreme Range:** If a unit is attacking at between Long range and four times its printed range, the attack is considered Extreme range; an attacker must roll a zero. (Only Veteran and Elite troops have a chance of hitting at Extreme range. Troop quality rules are additional and can be found on page 5.)

**Pistols and Rifles:** When a single-man pistol (PST) or rifle (Rifle) unit attacks, first calculate the number needed for the unit to hit (including troop quality, terrain modifications, etc.), and then divide that number in half (round all fractions up).

For example, a one-man Rifle unit is firing at another unit in the same hex. The base number for a Rifle to hit at this range is 4 (see Range Effects Table below). The Rifle unit then divides this number in half and gets a 2. The Rifle unit must roll a 2 or less to hit.

**Pistols:** Pistols (PSTs) are a special case when determining range. PST units always fire in the same hex (range 0) as if firing at Medium range; pistols may fire 1 hex (range 1) as if firing at Extreme range. Pistols always fire at one of these two ranges.

**Other Modifiers:** The chance of hitting the target is also affected by the quality of

the firing troops and the terrain occupied by the target troops. These modifications are expressed as additions to or subtractions from the number needed to hit, and are summarized on the table below.

## HIT MODIFIERS

Condition	Modifier
Novice	- 1
Trained	0
Veteran	+ 1
Elite	+ 2
Firing into rubble	- 1
Firing into woods	- 1
Firing into town	- 1

## CASUALTY DETERMINATION

If a unit does not hit its intended target, there are no casualties produced. If it does hit its intended target, it produces casualties equal to its attack strength. However, the target player first has an opportunity to make a saving die roll.

**Saving Roll:** The target player rolls one die per attacking strength point. The base saving throw number is one, but this is modified by the unit's troop quality (see page 5). After adjustments have been made for troop quality, Elite troops save on a three or less, Veteran on a two or less, and Trained on a one or less. Novice troops cannot make saving rolls.

For each successful saving roll, subtract one from the enemy's attack strength. The resulting attack strength is the number of casualties taken by the target unit. (Saving rolls may reduce this to zero.)

**Shotguns:** Units attacked by shotguns (SG) may not make saving rolls.

## LINE OF FIRE

In order to be attacked, a target unit must be in the attacker's line of fire (LOF). The line of fire is a straight line from the firing unit to the target. The line of fire is blocked if it passes *through* any intervening woods or town hexes, any friendly unit, or any wreck. If the line of fire is blocked by one of these obstructions, the target may not be attacked. A unit in a blocking terrain hex can see and fire *out* of that hex, and enemy units can see and fire *into* the hex, but no unit may see or fire *through* the hex. A unit may fire into a hex which contains both friendly and enemy units.

Terrain which is higher in elevation than both the firing and target units blocks the line of fire. (If a hex contains two different elevation lines, the higher of the two elevations applies; this is also true for movement.) A unit may fire into a hex which is one elevation higher but may not fire through that hex.

## RANGE EFFECTS

Range	Close	Medium	Long	Extreme
Distance	½ or less	Equal or less	2 × or less	4 × or less
Roll to Hit	4	2	1	0

*Note:* Round all fractions up when calculating range.

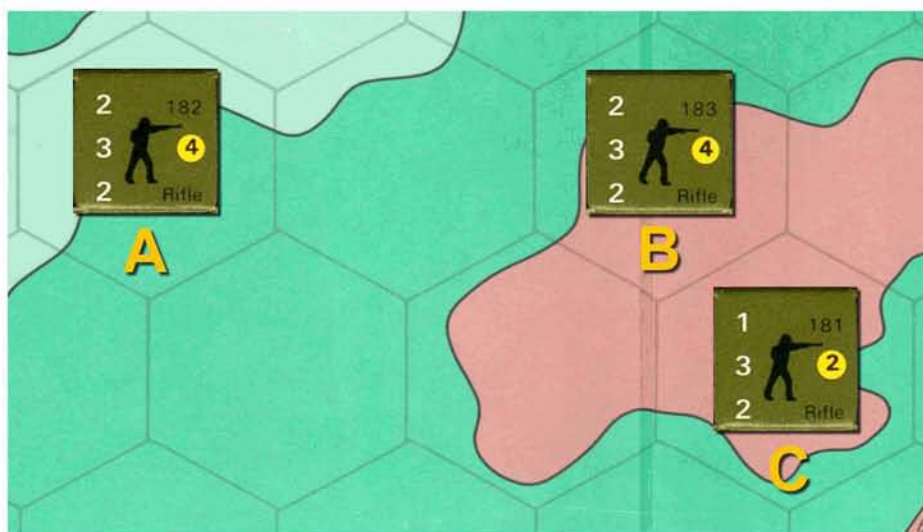

Unit A can see and shoot at B, but not C.  
 Unit B can see and shoot at A and C.  
 Unit C can see and shoot at B, but not A.

Units on high ground can see and fire over LOF-blocking units and terrain in lower-elevation hexes. Town and woods hexes cast a one-hex shadow, as does smoke, making units directly behind those obstacles unspotted by units on higher terrain.

An attacking unit may not fire at an enemy unit which is on a lower elevation if the LOF passes through one or more hexes of the same elevation as the attacking unit.

An attacking unit may not fire at a target unit on a higher elevation if the LOF passes through one or more hexes of the same elevation as the target unit (see diagram on page 4).

## GRENADES

Infantry units may elect to throw grenades at targets in the same hex. If the infantry unit is a leader or a single infantryman, then he may throw the grenade *instead* of firing his weapon. If the infantry unit is a multiple infantry unit, it may throw a grenade but must subtract 1 from its attack strength if firing other weapons in that phase. The grenade has a range of 0 and an attack strength of 4. Grenades always attack as if at Medium range and are treated the same as any other attack.

## TROOP QUALITY

Troop quality measures the level of training and experience that an infantry has had. Better trained and more experienced troops have a much better chance of staying calm, shooting well, and surviving. The Troop Quality Chart shows the modifiers for different troop qualities. These modifiers are referred to again in the appropriate places, but they cover such things as a unit's chance to hit an enemy unit, a unit's ability to save versus an enemy attack, and a unit's ability to spot concealed enemy troops.

Each scenario lists troop qualities. Record the ID numbers of the counters and their troop quality on a separate piece of paper.

### TROOP QUALITY CHART

Troop Quality	Modifier
Novice	-1
Trained	0
Veteran	+1
Elite	+2

*Note:* These troop quality modifiers are always the same, whether being applied to attacks or saving throws; this is why, for instance, a Novice has no chance to make a saving throw (the base saving throw roll is 1, but the Novice receives a -1 modifier, resulting in 0, or no chance).

## REACTION FIRE

All units of the nonmoving player may fire during the Reaction Fire Phase. Each one may fire at any enemy unit which is within or moved within its range, and may do so as if firing at any time during the enemy unit's movement. This fire is resolved in the same manner as any other attack.

## COMBAT EXAMPLE

A two-man Veteran assault rifle (AR) unit attacks an Elite two-man pistol unit two hexes away. The AR unit's range is 2, and the enemy unit is two hexes away, making the attack range Medium, so the AR unit must roll a 1 or 2. But the firing unit is also Veteran, so it gains a +1 modifier. The AR unit must roll a 3 or less to hit ( $2 + 1 = 3$ ). It rolls a 2, which is a hit. The AR unit's attack factor is 2, so the PST unit must make two saving rolls. The base number to save is 1, and the PST unit is Elite, so it gains a +2 modifier to avoid damage; it must roll a 3 or less to save ( $1 + 2 = 3$ ). It rolls a 4 and a 1, meaning the PST is reduced one level (one man). The two-man PST unit is replaced with a one-man PST unit.

## SPOTTING

Any unit which is not in the LOF of an enemy unit is concealed.

Only units which are spotted may be attacked. A target unit is spotted if an enemy unit can trace an LOF to that unit, unless the target unit is concealed.

**Concealment:** Units in town and woods hexes are concealed. They remain concealed unless and until they conduct an attack, they move out of the hex, an enemy unit moves adjacent to them, or an enemy unit makes a successful spotting attempt. When any of the above happen (assuming the concealed unit is in the LOF of an enemy unit), it is spotted. If a spotted unit moves into a woods or town hex, it immediately becomes con-

cealed unless it is also adjacent to an enemy unit. To indicate that a unit (or stack of units) is concealed, flip them over to their back "concealed" side. If a concealed unit is spotted, flip it over to reveal its front side.

A unit may make one spotting attempt per phase per concealed enemy counter, but only the unit with the best chance of success may make the attempt. The unit must have a LOF to the concealed unit. To spot a concealed enemy, roll on the Spotting Chart.

### SPOTTING CHART

Range (in hexes)	1	2	3	4
Roll*	A	4	3	2

A: Automatic spot. \*: Roll this number or less on one die to spot.

### MODIFIERS TO SPOTTING

Condition	Modifier
Novice	-1
Experienced	0
Veteran	+1
Elite	+2
Spotting a Vehicle	+1
Spotting From a Vehicle	-1

*Note:* The above modifiers are to the number needed to roll in order to successfully spot an enemy unit. Thus, an Elite troop trying to spot a enemy unit 4 hexes away would need to roll a 4 or less ( $2 + 2$ ).

**Dummies:** A certain number of dummy units are provided to the defender in some scenarios in order to confuse the situation. Dummy units may not move or attack. Once spotted, the dummy is removed from play.

You May Now  
Play Scenario **1**

155mm Howitzer

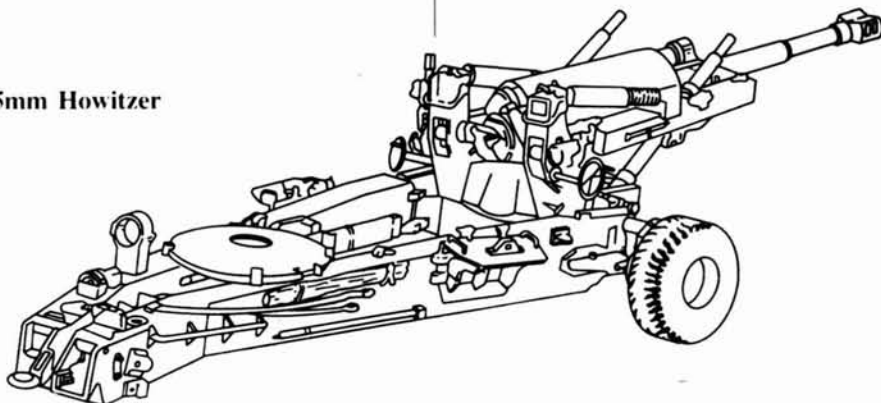

# Advanced Rules: Vehicle and Urban Warfare

One of the most valuable methods of assessing your enemies' strengths and capabilities is by capturing some of their equipment, particularly armored fighting vehicles such as tanks and APCs. Vehicles and equipment inevitably fall into enemy hands. To simulate this, the vehicles in **Last Battle** are printed in either green (for NATO forces) or brown (for Warsaw Pact forces), but the scenarios will often allow a player to own and control several captured vehicles. For this reason it is helpful to record on a piece of paper the ID numbers on the counters of the vehicles you control at the beginning of a scenario.

## FACING

Facing is a term which describes how a counter is positioned inside a map hex. In **Last Battle**, all vehicle counters must be positioned with the top of the counter (the front of the vehicle) pointed toward a hex side. See the diagram below.

It costs no MPs to change facing, and any unit which is not immobilized, destroyed, or a dummy marker may always change facing within a hex. However, a vehicle which stays in the same hex during its Movement Phase but makes a facing change is no longer considered concealed for spotting purposes. Also, any unit which changes its facing in the Movement Phase is not eligible to fire in the Attack Phase.

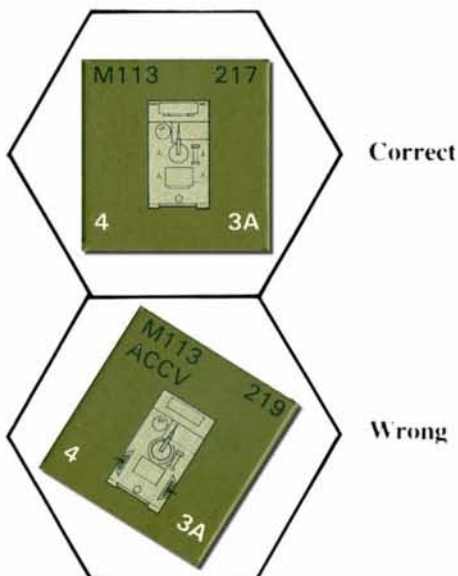

**Roads and Trails:** Vehicle units have two movement factors listed on their counters. The first factor (in the bottom left-hand corner) is the number of MPs the vehicle may expend if moving along a road (not a trail). The second factor (in the bottom right-hand corner) is the number of MPs the vehicle may expend if it is travelling offroad.

To use the road movement factor, a vehicle must begin the Movement Phase on a road and must stay on the road for its entire movement.

Trails are considered offroad terrain for all vehicles except High Mobility Multipurpose Wheeled Vehicles (HMMWVs).

**Elevation:** Whereas infantry may cross a two-level difference in elevation, a vehicle may only cross up to a one-level elevation difference.

**Stacking:** Each player may not have more than four of his vehicles in one hex at the end of any turn (this includes immobile and destroyed vehicles). This number is reduced to two if the hex is a road hex. Any number of other units and markers may be present.

Enemy vehicles, however, may never occupy the same hex. A friendly vehicle unit may move through hexes with other friendly vehicles but may not end its turn in a hex with four other vehicle units. Troops may enter hexes with enemy vehicle units. Any number of troop units (friendly or otherwise) may occupy the same hex, and any number of troop units may be stacked with enemy vehicles.

**Mounting and Dismounting Vehicles:** A troop may mount a vehicle if both the troop and the vehicle are in the same hex and if each pays 1 MP. Dismounting also costs both the troop and the vehicle 1 MP. Troops are dismounted into the same hex as the vehicle carrying them. Generally, only trucks and APCs (armored personnel carriers) carry troops. Consult the vehicle card for limitations on the number of troops which can be carried. Troops who dismount during the Movement Phase may not fire in the Attack Phase.

Armored personnel carriers are identified as such on their vehicle cards. Although APCs usually begin a scenario with their associated troop unit already mounted, any troop unit can mount and ride any friendly

APC, regardless of its designation. A vehicle's crew is subject to the same mounting and dismounting MP restrictions as troops (see *Escape From Destroyed Vehicles*).

**Amphibious Vehicles:** Vehicles which have the letter A after their offroad movement allowance are amphibious and may cross water hexes as well as travel along them.

**Crossing:** To cross a river (move through a water hex), the amphibious vehicle must begin its movement phase adjacent to the water hex it wishes to enter and may then move across it. Moving through a water hex consumes half the vehicle's movement factor (rounding fractions down). The vehicle must pay the normal terrain cost of the hex it enters from the water hex. Note: If the vehicle is unable to pay the terrain penalty, it must remain in the water hex or may move to an adjoining water hex (see *Travelling*).

**Travelling:** Any amphibious vehicle may drive up or down a river by expending half its movement points for each water hex it enters (thus, all amphibious vehicles may move along a river at the rate of two hexes per turn). The amphibious vehicle does not pay the terrain cost of the hex. To exit a water hex, the amphibious vehicle must be adjacent to the hex it wants to enter and then pay the normal terrain penalty for entering that hex. Any remaining MPs may be expended in land movement.

**HMMWVs:** High Mobility Multipurpose Wheeled Vehicles (pronounced HUM-veez) treat trails exactly like roads; thus, a HMMWV may use its onroad movement factor when driving on trails.

**Carrying Capacity:** Each vehicle unit has a vehicle sheet which tells how many crewmembers are onboard and how many additional troops can be carried. The counters which represent the vehicle's crew and passengers are placed in the appropriate boxes on the vehicle card. The vehicle counter placed on the map represents the vehicle, its crew, and its troops.

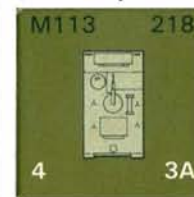

## ATTACKING WITH VEHICLES

Much of the information concerning combat with vehicles is contained on the individual vehicle cards, rather than the counters. While several of these cards are included in the game, we recommend that you make additional photocopies of them, and permission is expressly given for you to do so.

Each vehicle card lists the vehicle's weapons. Most vehicle cards have an Armament Chart which lists the weapon's name, its antivehicle capability (if any), and its antipersonnel capability.

### ARMAMENT CHART

<i>Weapon</i>	<i>Antivehicle</i>	<i>Antipersonnel</i>
120mm	70, 20	3, 16

The format for the weapon's statistics is: strength, range. So the 120mm gun would have a strength of 70 and a range of 20 when attacking vehicles, and a strength of 3 and a range of 16 when attacking personnel.

A few vehicle cards do not have Armament Charts, but instead have a list of weapon types that they may carry (GPMG, HMG, etc.) and a box to place the grey weapon counter in. The weapon strengths and ranges are already printed on the counter. Consult the scenarios to find which precise type of weapon is to be mounted. (See portable weapons under Infantry Versus Vehicles on page 8.)

A vehicle with multiple weapons may only fire one of its attack factors in an Attack Phase. It may also fire only one weapon in the Reaction Fire Phase.

More than one unit may fire at a single enemy unit, but all attacks must be declared before any are resolved. Fires declared against a target which becomes destroyed may not be shifted to another target.

## ATTACKS AGAINST VEHICLES

The combat sequence for resolving attacks against vehicles is conducted in three steps: hit determination, hit location, and damage assessment.

**Hit Determination:** Only weapons with an antivehicle attack strength may attack armored vehicles. Antivehicle strengths are noted on the Armament Chart of each vehicle's data card. For weapons represented by separate counters, antivehicle strengths are printed in black rather than white. Hit determination is done in the same way as for fire attacks by troops, except that the printed ranges are generally quite a bit longer.

**Rangefinders:** Some scenarios specify special rangefinders for vehicles. These give a bonus to the chances of hitting. The bonus

is expressed as an addition to the basic number needed to hit. The bonus applies only to the main weapon (the first one listed on the vehicle's Armament Chart), and may never raise the basic number needed to hit to more than four. Rangefinder modifications are made before any modifications due to terrain or troop quality.

**Missiles:** Antitank guided missiles (ATGM) have their chances of scoring a hit halved (round fractions up) when firing at a target in a woods hex.

**Hit Location:** If the vehicle is hit, consult the Location Chart on that unit's vehicle card, and roll a die. The result will be either Miss, Hull, Turret, Tread, or Wheel. A Miss result means the shot flew over the vehicle; there is no further effect. With any other result, go on to damage assessment.

**Damage Assessment:** Determine the angle of attack of the firing shot and find the appropriate armor value (listed on the target unit's vehicle card). Create a ratio of the attack strength of the shot to the armor value of the vehicle, rounding fractions down in favor of the target. Locate the corresponding column of the Vehicle Combat Results Table, roll a die, and determine the result. Ratios below 1:3 have no effect on the target vehicle; ratios higher than 5:1 are treated as 5:1. Four results are possible: No Effect, Minor damage, Major damage, and Destroyed. A No Effect result has no effect on the target vehicle, while a Destroyed result completely destroys the vehicle; remove its counter and replace it on the map with a "Burning Wreck" marker.

Note that when attacking soft vehicles (those with an armor rating of 0), all attacks are conducted at the 5:1 odds ratio.

Minor and Major damage require one additional step. Minor or Major damage to the wheels or treads immobilize the vehicle; place a "Mobility Damage" counter on it to indicate that it may not move for the rest of the scenario. A Minor or Major damage result to the turret or body is resolved by rolling a die and consulting the appropriate damage table on the vehicle card. This will indicate which specific type of damage is suffered.

**Attack Strength Modifiers:** Antiarmor weapons which rely on the kinetic energy of their projectiles to penetrate the armor of the target lose effectiveness with range. These weapons comprise all main guns of tanks and armored vehicles as well as ground-mounted heavy machineguns (HMG). They do not include automatic grenade launchers (AGL), antitank rocket launchers (ATRL), or antitank guided missiles (ATGM). Kinetic energy antitank weapons have their attack strength doubled

at Close range, halved at Long range, and quartered at Extreme range, rounding all fractional strength values up.

## TYPES OF DAMAGE

Always consult the vehicle card for additional notes when assessing damage.

**Crewmember(s):** If a crewmember is killed, in the next Movement Phase the player may reassign remaining crew to vacant positions; the crew may immediately perform their new functions (including firing weapons). Possible crew hits follow.

**Driver:** If the driver is killed, the vehicle may no longer move. If a new driver is assigned, the vehicle's movement is permanently cut in half (round fractions up). This limitation is to simulate another crewmember's relative unfamiliarity with driving the vehicle.

**Commander:** If the commander is killed, the vehicle may not spot concealed units. In addition, the vehicle may not fire its heavy machinegun (M2HB, DShK, KPV), assuming it has one, unless that is the only weapon mounted on the vehicle.

**Gunner:** The vehicle may not fire its primary weapon (the weapon listed first on the Armament Chart on the vehicle card). If this position is filled by another crewmember, the primary weapon may not be fired in the Reaction Fire Phase.

**Loader:** If the loader is killed, the vehicle's main weapon (the first one listed on the Armament Chart) may not be fired in the Reaction Fire Phase.

**Troops:** Roll one die for each person in the unit separately (in the same manner as saving throws) with a 1-3 resulting in a kill and a 4-6 indicating no damage.

**Treads/Wheels:** Any result other than NE means the vehicle is immobilized. Place a "Mobility Damage" marker on the vehicle counter.

**RF:** The range finder is destroyed. The vehicle receives a penalty of -1 when trying to hit an enemy with the main weapon.

**Radio:** The radio is destroyed; same result as Commander, above. Place a "Radio Damage" marker on the vehicle counter.

**Weapon:** Check the vehicle card for the specific weapon hit; that weapon is destroyed. Place a "Weapon Damage" marker on the vehicle card.

**Engine:** The engine is destroyed. The vehicle may not move or change facing. Place an "Engine Damage" marker on the vehicle counter.

**Fuel:** On a roll of 1-5, the fuel ignites, and the vehicle explodes. A Burning Wreck marker is placed over the vehicle (see Escaping From Destroyed Vehicles). On a



roll of 6, there is no effect.

**Ammo:** The ammunition explodes, and the vehicle is destroyed. A Burning Wreck marker is placed over the vehicle (see Escaping From Destroyed Vehicles). Consult the vehicle card for possible exceptions.

### COMBAT EXAMPLE

An M2 Bradley tank is attacked from behind by a T-72. The T-72 fires its 125mm gun which has a range of 20, and the M2 is 12 hexes away, so the attack is conducted at Medium range (the attacker needs a 2 or less on one die to hit). The attacking player rolls a 2—the M2 is hit. The M2 player consults the Location Chart on his vehicle card and rolls a 3, which indicates that the Body of the M2 was hit. The M2 player then consults the vehicle diagram on his vehicle card and finds that he has a rear body armor value of 2. The attack value is 70 for the T-72's 125mm gun, and the M2's armor value is 2, which yields a 5:1 ratio. A roll of 4 in the 5:1 column of the VCRT yields a MAJ result. He then consults his Body Major Damage table. He rolls a 2 on that table, which is an Ammo result. The M2 is destroyed, a "Burning Wreck" marker is placed on the vehicle counter, and the crew must try to escape.

### ESCAPING FROM DESTROYED VEHICLES

A troop, crew, or leader mounted on a vehicle which is destroyed by an attack is very often destroyed by the attack as well. The mounted unit escapes on a roll of 1, 2, or 3, and is placed in the hex with the vehicle. If a troop-carrying vehicle is only damaged by combat, the troops automatically dismount at no MP cost.

### INFANTRY VERSUS VEHICLES

Infantry units may occupy the same hex as friendly or enemy vehicles and have a variety of means available with which to attack them.

#### Soft Vehicle Attacks:



Strength and range values printed in white (which include all infantry weapons and many heavy weapons) may not be used to attack armored vehicles; however, they may be used to attack soft vehicles. A soft vehicle is attacked as if it were a troop unit, with several exceptions. The attack strength of the firing unit is the number of separate fire attacks made against the vehicle. No saving rolls are allowed in the event of a hit. Each actual hit is rolled for separately on the vehicle's Location Chart, and damage is assessed for each hit by a single roll on the 2:3 odds column of the Vehicle Combat Results Table.

**Grenades:** Troops may throw grenades at vehicles. If the attack is against an armored vehicle, consult the vehicle sheet—only a Tread or Wheel result indicates damage; any other result has no effect.

A grenade thrown against a troop unit or a soft target is treated like any other attack. Grenades may only be thrown in the same hex (range 0) and attack as if at Medium range.

Helicopters may not be attacked with grenades.

### PORTABLE WEAPONS

Some weapons are represented on grey counters and have no inherent infantry. These weapon counters must be stacked with infantry units in order to be used. If the infantry unit is killed, the portable weapon counter is left on the board. Any infantry unit (friendly or enemy) may pick it up (by moving into the hex) and may use it normally.

These weapons may also be mounted on some vehicles. In this case, the counter is placed on the vehicle card. If the weapon or vehicle is destroyed, the weapon counter is removed from the vehicle card. The anti-armor factors are listed in black; their soft target factors are listed in white.

**Portable Antitank Weapons:** These weapons are represented on separate counters and are stacked with the troop units which are carrying them. Any one-man troop unit may carry an antitank missile. In combat, the troop unit may elect to fire the missile or attack with its usual weapon (PST, AR, etc.). Once the missile is fired, flip it over. If there is a "1" on the back side, then the missile may be fired one more time. If there is a "0" on the back side, the missile launcher must be discarded. Once a missile launcher has used all its missiles, remove the counter from play.



**Tank Breaker:** The Tank Breaker (Tankbr) can be programmed to hit either the side of the vehicle closest to the firer, or to fly over the vehicle and attack it from above. The player firing the Tank Breaker must specify which mode it is programmed for. If programmed for a normal attack, the fire is resolved normally. If programmed for an overhead attack, two exceptions are made to the normal procedure. First, all hit location results of Tread or Wheel are treated as misses instead. Second, any other hit location is resolved using the lowest armor value of the vehicle.

**Heavy Weapons:** The TOW II, all automatic grenade launchers (AGL), and all heavy machineguns (HMG) are heavy weapons. Heavy weapons normally require a

crew of two soldiers. If only one soldier is carrying the weapon, he has a movement factor of 1, not 2. If only one soldier is firing the weapon, it may not be fired during the Reaction Fire Phase.

### MISSILES

Missiles (ATGM) have several restrictions on their use which gun-armed units do not. These restrictions are summarized again here for clarity.

Missiles cannot attack beyond the range printed on the counter, and they can never be used to attack units in the same hex. Missiles can only be fired against vehicles; they have no effect against troops. Missiles always attack as if at Medium range.

Missile hit chances are halved when firing at targets in a woods hex.

Missiles may not attack units in the same hex.

Missiles never halve or double their attack factors due to range.

### CAVALRY

Any infantry unit may be mounted on a horse. Place the infantry counter on top of the horse counter on the map.

To mount or dismount a horse, both the infantry unit and the horse must be in the same hex and spend 1 MP. In any player-turn (except those in which the infantry unit mounted or dismounted), the infantry unit may both move and fire.

**Attacks:** When mounted, any infantry unit fires at a -1. If a mounted unit is hit, roll a die for each casualty sustained: On a 1-4, the horse is killed (the infantry unit automatically dismounts and may not take any other action that player-turn); on a 5-6, the infantry unit is hit.

### URBAN COMBAT

The following rules allow for more detail and realism.

**Vehicles:** Vehicles may only move through town hexes with roads: They may not move through rubble or building hexes which do not also have roads. Vehicles must also "follow the road."

**Infantry:** Infantry may move through any hex (rubble, buildings, and roads, etc.). They may also enter any building with a grey square on top of it. It costs 1 MP to enter the building and 1 MP to leave it. Once inside a building, an infantry unit gains a +1 when firing at enemy units, and enemy units firing at the infantry unit incur a -1 penalty. Infantry units inside a building may not hide (see Special Rules).

**Line of Fire:** Buildings block LOF.

# Special Rules

## MORALE

Battles are most often lost when one side breaks; rarely does a battle end with everyone on a side dead. Every casualty a side takes undermines its morale somewhat, but even while taking heavy casualties a force will often continue to fight if it has good leadership.

**Leaders:** Each **Last Battle** scenario will specify how many leaders are present. The player is free to choose which counter represents the leader (it must be a single-man counter with either a PST, SG, SMG, Rifle, or AR). The player should record the ID number of the counter on a piece of paper for future reference. Leaders always function as Elite troops.



If a leader receives one attack point of damage in combat, instead of removing him from the board, place an "Injured" marker on his counter. A second point of damage in combat kills the leader.

**Morale Procedure:** Some scenarios state a morale level for the beginning of the battle, along with a hesitation point and a break point. As units are destroyed during a battle, the morale level declines. As units are lost during a battle, place them aside and note their morale points. At the end of each player-turn, compare the total morale points lost on a side with the scenario's hesitation point and break point.

### MORALE POINT LOSSES

Unit Type	Morale Points
Leader	3
One Infantryman	1
Soft Vehicle	4
Armored Vehicle	6

When morale point losses bring a side to its hesitation point, it loses the initiative (if it has initiative).

When morale point losses bring a side to its break point, it will break off the engagement and withdraw. The scenario is over, and the other side has won the battle (but not necessarily the scenario).

If the remaining player can then achieve his victory conditions, he wins. If he cannot, the scenario is a draw.

**Mutual Hesitation:** Once both sides have hesitated, the initiative switches randomly between the two sides every turn. Every turn, the attacking player rolls a die and has the initiative on a roll of 1-3; otherwise, the defending player has the initiative for that turn.

**Optional Rule:** Novice and Trained troops may not advance toward a spotted enemy unless the troops are in or adjacent to a hex with a friendly leader.

## HIDING



A unit which does not move during its Movement Phase may hide; place a "Hiding" marker under the unit. This means that the unit has dropped prone and has taken advantage of any cover that the terrain provides. A unit may not fire in the first player-turn that it hides. Firing at units which are hiding is done at a penalty of -1. As soon as the unit moves, it loses all benefits of hiding. A unit which is hiding is not necessarily concealed.

## You May Now Play Scenario 2

## ARTILLERY

Artillery fire is delivered by howitzers and mortars which are typically deployed off the game map. Artillery fire is controlled by a forward observer (FO) who directs it by radio.

If the scenario does not specify ammunition, you may choose any 10 rounds for each artillery piece.

**Off-Map Artillery:** Off-map artillery consists of long-range mortars. The specific mortars available will be listed in the scenario; their effects are summarized in the Artillery Chart on this page.

**On-Map Artillery:** On-map artillery consists of short-range mortars (namely the 82mm). On-map artillery fire is conducted like any other on-map attack. That is, it can be fired during the Attack Phase if it did not move in the Movement Phase. On-map ar-

tillery may be moved about the board, but it has the following restrictions.

- Mortars may not fire while they are hitched (limbered) to a vehicle. To unlimber a mortar, the towing vehicle pays 3 MPs. The mortar may not fire until the Attack Phase of the next friendly player-turn. Once it has fired in the Attack Phase and as long as it is not limbered again in a Movement Phase, it can make a reaction fire attack (one salvo).

- To limber a mortar, the towing vehicle must begin its Movement Phase in the same hex as the mortar and spend 3 MPs. If the vehicle has any MPs remaining, it may then move (towing the mortar).

- On-map artillery can either make a direct-fire attack against a unit in its LOS or make an indirect fire attack against a unit that is in the LOS of any forward observer. An FO used to plot a fire mission for off-map artillery at the beginning of a turn can also be used to call indirect fire from any number of on-map artillery units in the same turn. On-map artillery has restricted movement factors; it cannot both move and fire in the same turn.

**Fire Missions:** Artillery fire against a target is called a fire mission. Fire missions are requested at the beginning of the turn (before either player begins his player-turn) and are resolved at the end of the turn (after both players have completed their player-turns). Each artillery unit available may shoot one fire mission per turn. If artillery fire is available in a scenario, the scenario will identify the number and types of artillery units available to each side.

**Targeting:** The firing player indicates the specific target hex he wants the artillery fire to hit. One target hex may be indicated for each unit firing. Players record their selected target hex in secret on a piece of paper. At the end of the turn both players place their artillery markers in the target hex and resolve fire missions. If more than one salvo is fired, the marker is left in the hex throughout the next turn. All units (of both sides) which pass through the hex are attacked by the artillery. The marker is removed at the end of the turn when new fire mission markers are placed.

**Forward Observers (FOs):** In order for

an off-board artillery unit to perform a firing mission or an on-board artillery unit to conduct indirect fire, an FO must be able to see the target being attacked and communicate with the artillery that is firing the salvo.

Any vehicle or leader who did not move in the Movement Phase may be an FO. A unit may not be an FO and also attack in the same Attack Phase.

The FO must be able to trace a line of sight to the fire mission target hex. A line of sight is identical in all respects to a line of fire except that friendly units do not block it. An FO can direct only one fire mission per turn.

**Concealed Units:** An FO can direct artillery fire at any hexes which contain concealed units. When the artillery fire is resolved, the player owning the target unit checks to see any results achieved on the type of unit being fired upon. If a result is called for, it is applied to the unit but does not cause the unit to become spotted. An "X" result destroys the vehicle; reducing a troop unit's attack strength to 0 removes that unit from play.

**Salvoes:** One attack by an artillery unit is called a salvo. Different types of artillery can fire various numbers of salvoes in one fire mission in one turn. After the first salvo is resolved, the firing player may decide to fire a second salvo (if the artillery has that capability), then a third and a fourth (again, assuming the artillery type has that capability). Salvoes beyond the first are always voluntary.

Salvoes are distinguished by type (HE, smoke, chemical, and others). Any mix of available salvoes can be fired in a fire mission. Scenarios specify the number of sal-

voes (by type) available and the maximum total number of salvoes which can be fired in the battle. For example, the scenario may state that three HE salvoes and three smoke salvoes are available, with a maximum of four salvoes total.

The rate of fire (ROF) listed on the Artillery Chart is the maximum number of salvoes which the weapon can fire in a turn. The 203mm howitzer has a ROF of ½, indicating that it may only fire every other turn. Multiple rocket launchers always have a ROF of 1 and may only fire once per scenario. (After a full salvo is fired, the launcher has exhausted its supply of rockets.)

The type of weapon fired determines the pattern of hexes hit by the attack. Howitzers and mortars hit the target hex; multiple rocket launchers hit the target hex and all six adjacent hexes.

#### MORTAR AND HOWITZER PATTERN



#### MULTIPLE ROCKET LAUNCHER PATTERN

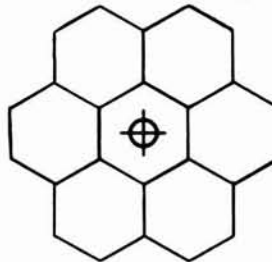

**High Explosive (HE) Fire:** HE salvoes attack each vehicle in the target hex and collectively attack all troops in the hex. First, roll to see if the round hit. It hits on a roll of 1, just as if firing at Long range. This roll is made separately for each vehicle in the hex and once for all troops. If the attack hits a vehicle, roll for hit location normally

and resolve the attack as an antivehicle attack using the HE attack strength of the firing weapon. If the attack hits the troops in the hex, it causes casualties equal to the HE attack strength of the round. Troops may make their normal saving roll attempts, but add one to their chance of a successful roll if hiding and add two to their chances if in a building.

**Improved Conventional Munitions (ICM):** ICM salvoes attack in the same manner as HE salvoes, with the following exceptions. ICM hits on a roll of 1 or 2, just as if firing at Medium range. ICM has no effect on troops in buildings, entrenchments, or woods. Troops in clear terrain and which are not hiding may not attempt a saving roll. ICM has no effect on vehicles except for those weapons which have an asterisk after their ICM strength (4.2" mortar; 105mm, 155mm, and 203mm howitzers; 160mm and 227mm multiple rocket launchers). These weapons fire dual purpose ICM. Roll for a hit on the vehicle normally (as if at Medium range). If it is hit, roll for hit location as for an overhead attack from a Tank Breaker (all Wheel and Tread hits are misses), and use the ICM strength of the round versus the weakest armor value of the target vehicle to resolve damage.

**Illumination Rounds (Illum):** Weapons which have a numeric value in the Illum column of the Artillery Chart may fire Illum rounds. The effects of Illum rounds are explained in the Limited Visibility rule.

**Field Artillery Scatterable Mines (FASCAM):** Weapons with the notation "yes" in the FASCAM column of the Artillery Chart may fire scatterable mines, the effects of which are discussed on page 11.

### ARTILLERY CHART

Type	Range	ROF	HE	ICM	Illum	FASCAM	Points
<b>Mortars</b>							
60mm	25	4	2	—	1	—	2
81mm	30	2	3	—	2	—	2
82mm	20	10	3	—	2	—	4
4.2"	40	2	4	4*	4	—	5
120mm	35	2	4	—	4	—	5
<b>Howitzers</b>							
105mm	60	2	3	4*	4	—	5
122mm	100	2	3	6	4	—	6
152mm	120	1	4	10	6	—	7
155mm	160	1	4	10*	6	yes	8
203mm	130	½	6	15*	8	yes	9
<b>Multiple Rocket Launchers</b>							
122mm	130	1	5	—	—	—	7
140mm	70	1	3	—	—	—	5
160mm	160	1	3	6*	—	yes	10
220mm	230	1	5	10	—	yes	15
227mm	200	1	4	10*	—	yes	20

Note: Point cost is included for use with the scenario generation rules.

## You May Now Play Scenario 3

### LIMITED VISIBILITY

A unit may attack any unit which is visible and which is within range. Smoke and night can limit visibility.

**Equipment:** Units in Last Battle scenarios will usually have no special vision-enhancement equipment, but occasionally they will have thermal or infrared sights. The type of equipment available (if any) will be indicated in the scenario. Write these in under "RF" on the vehicle card.

**Night:** The limit of visibility at night for units without special sights is 16 hexes. For units with thermal or infrared sights, the limit of visibility is 40 hexes. Units with no

sights or with infrared sights adjust their range one level higher (e.g., a Medium-range attack becomes Long range). Note that for pistols, this means that only same-hex combat is allowed, and it is conducted at Extreme range. At less than half range, nonmissile attack factors (other than small arms) are still doubled, resulting in normal attack values.

**Illum:** Illum rounds fired by artillery units illuminate the target hex and all additional hexes within the distance listed on the Artillery Chart. The Illum round from a 105mm howitzer, for example, illuminates the target hex and all hexes within four hexes of it. All units within the illumination radius of the round may be seen normally, as if it were daylight. Illumination lasts for one complete turn.

**Smoke:** Units with no special sights cannot see into a smoke hex. Units with infrared sights can see into the first hex of smoke, but they cannot see through a smoke hex. Units with thermal sights can see through smoke to a maximum of 40 hexes.

Smoke can be called as an artillery fire mission, or it may be created by armor or infantry units.

#### SMOKE PATTERN

Wind Direction

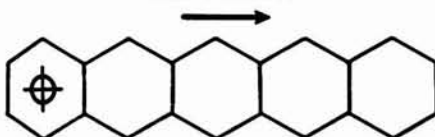

**Smoke Fire Missions:** All artillery units may fire smoke. Each smoke mission creates a smoke screen beginning in the target hex and extending downwind to a total length in hexes equal to the HE strength of the weapon. An 82mm mortar, for example, creates a three-hex smoke screen. Each additional salvo fired adds hexes to the smoke screen equal to its original length.

**Armor or Infantry Smoke:** Smoke may be created by armored vehicles and troop units during the Movement Phase. Smoke created by these units covers only the hex in which the unit began its Movement Phase.

**Height of Smoke:** Smoke is considered to be an obstruction one elevation high. For purposes of line of sight from higher elevations, smoke throws a one-hex shadow, just as town or woods hexes.

You May Now  
Play Scenario **4**

## MINES

Mines may be laid by engineers, or they may be scattered by artillery.

**Engineer-Laid Mines:** Mines may be laid by engineers using mine emplacement machinery. Engineer-laid mines cover one hex. The mines are in place before the scenario begins and may be specified as camouflaged or marked. If camouflaged, the location of the mines is noted secretly by the player who placed them: they are invisible to the other player until he enters a hex containing them. If marked, they are identified by a mine marker during the day. Marked mines at night are treated as camouflaged mines.

The scenario instructions will indicate how many engineer-laid mines (if any) are available.

**Field Artillery Scatterable Mines:** Field Artillery Scatterable Mines (FASCAM) are placed by an artillery fire mission. Each howitzer salvo places one hex of mines; each MRL salvo places seven hexes of mines in the same pattern as the HE pattern for multiple rocket launchers. This minefield is placed directly on the map unless the scenario takes place at night, in which case its location is secretly noted.

The scenario instructions will indicate how many (if any) FASCAM salvos are available.

**Mine Attacks:** Mines attack both sides indiscriminately. A player must be sure that if he enters his own secret minefield he declares the fact and resolves the attacks against his own troops and vehicles. Mine attacks are done as if at Medium range and have a attack strength of 2. Units are attacked immediately as they enter the mined hex. (If a unit is in a hex that FASCAM is dropped into, the unit immediately suffers a mine attack.) Vehicles which are hit are automatically hit in the wheel or track, whichever is appropriate.

## HELICOPTERS

Helicopters demand an inordinate amount of maintenance time (sometimes as much as 120 man-hours per week) and are delicate aircraft. For these reasons, only a handful have survived the war thus far. High-tech fighter aircraft, with their complicated computer equipment and exorbitant maintenance schedules, have not survived the war.

Helicopters are air units used according to the following rules.

**Movement:** Helicopter movement works much like other vehicle movement. The first movement factor listed on the helicopter's vehicle card applies only if it does not enter nap-of-earth flight at any point during its

Movement Phase. The second movement factor applies if it conducts any nap-of-earth flight during its Movement Phase.

Helicopters may fly either high above the terrain or nap-of-earth. When flying high above the terrain, a helicopter can spot any unconcealed unit on the board (and be spotted by it, in turn). But the helicopter cannot see concealed units, even if they are adjacent to it. When flying nap-of-earth, the helicopter is considered to be at the level of the terrain of the hex it is in, and normal LOF and spotting rules apply, as if it were a ground unit.

A helicopter can change from flying high above the terrain to nap-of-earth and back any number of times during its movement.

The helicopter included in **Last Battle** is an Mi-17 HiP transport helicopter which can carry troop units; consult its vehicle card. It takes a helicopter's entire movement allowance for a turn to mount or dismount any troops. Therefore, on any turn in which troops dismount from a transport helicopter, the helicopter must remain in the hex at nap-of-earth height for the entire game turn and may not conduct attacks.

**Firing:** Helicopters may conduct attacks in the same turn in which they moved.

## FIRING AT HELICOPTERS

Helicopters are fired upon slightly differently than are other units. The exact procedure used for firing on them depends on their flight mode.

**NOE Flight:** Helicopters in NOE flight mode are fired at exactly as if they were a soft vehicle on the ground.

**High Flight:** Helicopters in high flight mode may not be fired at by ATGM or ATRL weapons, any artillery weapon, or any vehicle main armament larger than 75mm. All other weapons fire at them as if they were soft vehicles, but do so at two range bands greater than the normal range calculation would indicate. For example, a weapon with a printed range of 6 would fire at any helicopter within three hexes as if at Long range and at any within six hexes as if at Extreme.

## CHEMICAL WARFARE

Chemical warfare attacks are delivered by artillery. They are plotted like any other artillery fire mission, and their primary effect covers a line of hexes like smoke. Their secondary effect covers the entire map.

After a chemical strike is made, all units on the map (except air units) must button up and take protective measures. This requires one turn, during which time no movement or fire may be performed by that unit, but artillery fire may still be plotted and

delivered. (Units may begin the scenario buttoned up; the controlling player should note the fact on paper.)

Any unit within one hex of the primary effect line when a chemical fire mission is delivered may suffer damage. Units within that area that do not have chemical protective equipment suffer an immediate attack at Medium range. Units that have chemical protective equipment available and spend the turn buttoning up—but that were not buttoned up before the fire mission occurred—suffer an immediate attack as if at Long range. (Unless a unit is destroyed by the attack, it is considered buttoned up for the rest of the scenario.) Units that were buttoned up before the fire mission suffer no damage.

For the duration of the scenario, all units on the entire map that are not buttoned up suffer an attack as if at Extreme range every turn.

**Degraded Effectiveness:** Units that are buttoned up against chemical attacks make all fire attacks at one greater range than normal (e.g., Close-range attacks become Medium range; this does not apply to artillery and air units).

**Escaping From Destroyed Vehicles:** In a chemical warfare environment, troops escape from a destroyed vehicle on a roll of 2 or less (rather than the usual 3 or less).

## You May Now Play Any Scenario



# Optional Rules

## COMMAND CONTROL

A unit is in command control as long as it begins its player-turn within five hexes of a leader.

At the beginning of each player-turn, roll a die for each unit which is out of command control, and add the troop's modifier (see the Command Control Modifiers Table below). On a 1, 2, or 3, the unit may not move in the current player-turn; it may, however, fire in the Attack Phase. On a roll of 4 or more it may move normally.

Leaders and air units are always in command control.

### COMMAND CONTROL MODIFIERS

Troops	Modifier
Novice	-1
Trained	0
Veteran	+1
Elite	+2

## LIMITED AMMO

Missile-firing units have only a limited number of missiles with them. To reflect this limit, each of these units may only fire its missile armament twice per scenario.

## COHESION

The cohesion of a unit is at least as important as its morale, perhaps more so. For purposes of cohesion, every individual maneuver element on a side is treated separately throughout the game. A maneuver element is defined as a leader, and all troops and vehicles which begin the scenario subordinated to him.

Whenever any unit of a maneuver element is fired at and suffers one or more casualties, it must roll a die and check cohesion. Cohesion checks are made at the end of the player-turn in which the casualties were suffered. A casualty result on the command unit of the maneuver element counts as two casualties for cohesion purposes. If the die roll result is equal to or less than the number of casualties the maneuver element suffered that player-turn, the maneuver element is disordered.

**Effects of Disorder:** A disordered maneuver element immediately loses the ability

to conduct reaction fire. In addition, all damaged vehicles are removed from play and replaced with Wreck Markers (since the crews have abandoned them). Place the crew counters in any hex adjacent to the vehicle.

In the next Movement Phase of the disordered maneuver element, all units must move away from the enemy. Each unit must move until it can no longer see any enemy units or until it exhausts its movement factor, whichever comes first. At the end of the move, all remaining troop units (but not crew) dismount from their vehicles (into any hex adjacent to the vehicle) and may not move further. None of the units of the disordered maneuver element may fire in the turn they retreat.

The effects of disorder are not permanent. Vehicles that have not been abandoned are free to move in their next Movement Phase, and troop units may move normally.

**Low Cohesion Troops:** Some troops have particularly low cohesion. These units are noted in the scenario as checking cohesion at +1. This means that they check as if they had received one more casualty than was the case. If the maneuver element is fired at but suffers no casualties, it still must check cohesion as if it had suffered one.

**High Cohesion Troops:** Some troops have particularly high cohesion and they are noted in the scenario as checking cohesion at -1. This means that they check as if they had received one less casualty than was the case. If they suffered only one casualty, they need not check cohesion at all.

M60A4



# Hints on Play

If you have a good understanding of how modern armies fight and *why* they fight that way, you are well on your way to becoming a master-level player.

## 1. FIREPOWER

The firepower and variety of weapons has increased dramatically in several decades. Individual infantrymen can now carry not only automatic rifles, grenades, and mines, but portable, laser-guided missile weapons which are able to destroy heavily armored tanks. In a war, however, the most powerful weapons are usually the first to be used, and the more delicate weapons will not last. Such is the case in **Last Battle**. WWII has ground on for several years now—equipment has been destroyed, captured, and worn out. Vehicles are rare, and so are armor-piercing weapons, but some do exist. It's difficult to plan ahead: Your enemy may have a T-90 tank and a helicopter waiting just over the hill, or he may have a few pistols and a worn out HMMWV.

The most important tactical challenge is to survive long enough to bring your own firepower to bear.

## 2. SURVIVING

No matter how well armored your vehicles are, the odds are that there is something out there that can kill you. Your best bet is to avoid giving the enemy a shot at you. To do this, you have to make maximum use of *cover* and *concealment*.

**Cover:** A physical obstacle to visibility and fire, such as a hill or woods. If there is a hill or woods between you and the enemy, you are reasonably safe. Most of the time, however, he is reasonably safe as well, and that's the disadvantage to the use of cover. At times, the intelligent use of cover can avoid this disadvantage, however. Mortars are a good example of this. If you have a concealed observer, you can place your mortars under total cover and fire with impunity. The observer will not be exposing himself by moving or firing, so you have the best of both worlds. A second example is an approach march. If you are attacking, you want to get as close to your objective as possible before exposing yourself to enemy fire, and covered routes of advance

are the method of choice. Finally, if you are defending a position against an enemy force that is equipped with longer-ranged weapons than you have, cover is a means of offsetting his advantage. If you are under cover, neither side can engage the other until the attacker crosses through the covering terrain. At that point your range disadvantage may not be a problem anymore.

For example, infantry with short-range antitank weapons would probably not want to defend the crest of a hill against enemy tanks, but rather would defend the reverse slope. If on the crest, the enemy tanks can blow the infantry away from a distance. If on the reverse of the crest, the tanks actually have to top the hill, and then they can be shot by your antitank weapons. If you are concealed on the crest of the hill, the enemy only has to send one unit forward to locate you, and then all of his tanks can concentrate their fire on you. If you are on the reverse slope and he sends one vehicle to scout your position, only that one vehicle can engage you, while you can concentrate all your fire back at him. And once that vehicle is knocked out, you are no longer visible.

If you have a few long-range weapons, you can combine them with the defense listed above fairly easily. Put them on the reverse slope as well, but place them so that they can fire to your flanks. That way if the enemy tries to send a group to outflank you, your long-range weapons can fire at them while the majority of your short-range weapons guard against the direct assault across the crest of the hill.

**Concealment:** Consists of using the surrounding terrain to deny your enemy a clear view of your position, while maintaining clear fields of fire for your own weapons. For example, tanks deployed on a woods line can fire out freely but are difficult to spot due to the concealment offered by the trees and brush. Effective use of concealment, particularly in conjunction with the use of dummy units, forms the basis of all ambush tactics.

## 3. SUPPORTING FIRES

In general, it is easier for the attacker to use artillery effectively than for the defender, since the defender is more or less

tied to a particular chunk of terrain. You know where the defender is likely to be in a few minutes. The attacker, on the other hand, is moving rapidly, and it is extremely difficult for forward observers to make sure artillery keeps correcting onto enemy advancing units.

## 4. MOBILITY

Firepower kills units, but mobility wins battles. Many of the scenario objectives reflect this directly, but this has a broader tactical validity as well. Aggregate firepower of a force is important in a theoretical sense, but for practical purposes all that matters is how much you can bring to bear on the enemy. What this usually means is that the side which can best concentrate its firepower at the critical point will win.

A number of factors affect concentration of force. (Longer range on your weapons, for example, extends the area over which you can concentrate the fire of several weapons in different positions.) The most important variable affecting concentration of force, however, is mobility. If you stop moving, the enemy will be able to concentrate his troops from all over the map to deal with you. If you keep mobile, however, he can't concentrate his forces nearly as well without risking leaving you an open flank to turn.

## 5. COUNTER-MOBILITY

If defending against a well conceived attack, you must always think in terms of denying the enemy mobility. Once the enemy stops moving forward, half the battle is won. Players always dream of setting up perfect killing zones, but the enemy will never wander into a killing zone unless you make him do so. You may push him into that option, however, by denying him mobility along other routes of advance.

To deny your enemy the mobility he needs to win, try several things. If you have mines, lay them to deny some avenue of approach and then concentrate your fire on the remaining open route. If the terrain is open, place long-range fire assets well back out of the way to snipe at the enemy; if the terrain is congested and broken up, sew infantry in his way to clog up his movement.

# Last Battle and Twilight: 2000

This chapter gives all the necessary information on how to convert **Twilight: 2000** characters, weapons, and vehicles into **Last Battle** and back to **Twilight: 2000**.

## PLAYER CHARACTERS

All player characters are considered to be leaders in **Last Battle**. All player characters save versus attacks as if they were Elite (they must roll a 3 or less to receive no damage). If the character fails to save and rolls a 4, he has received a slight injury (no wound marker is placed on the character, but the referee may penalize the character by reducing his movement rate, lowering his chance to hit, etc.). If the character rolls a 5 or 6, he receives a Wound marker and a serious wound (the referee may allow the character to retain consciousness or may make him roll against his CON as per the standard **Twilight: 2000** rules). The second wound becomes a critical hit (on a roll of 5 or 6), and a second Wound marker is placed on the character.

Any player character who receives two wounds is unconscious. The character must receive medical help within 10 minutes (20 game-turns), or he is dead. Another PC (or NPC) with MED must spend two game-turns in the same hex as the unconscious PC and roll versus his MED skill as per standard **Twilight: 2000** rules. The character may not move or attack while treating the unconscious character.

Once the battle is over, roll normally for NPC hits as per the **Twilight: 2000** rules.

**Skills:** Most character skills in **Twilight: 2000** transfer into **Last Battle** as die roll modifiers. The Translation Chart below shows the skill levels, the **Last Battle** equivalent in troop quality, and the resulting die roll modifiers.

## TRANSLATION CHART

Skill Level	Troop Quality	Modifier
0-25	Novice	-1
26-50	Trained	0
51-75	Veteran	+1
76-100	Elite	+2

A player character with RCN60 would receive a +1 bonus when attempting to spot a concealed enemy unit. A player character with PST80 would add a +2 to the number needed to hit an enemy unit when shooting a pistol.

**Coolness Under Fire (CUF):** At the beginning of each friendly player-turn, roll for each PC and NPC on the board to determine whether they can act this turn. You must roll half their CUF or greater (round fractions up) in order for them to act. If you roll below this number, the unit may take no actions this player-turn but is eligible for reaction fire in the enemy player-turn.

For example, a PC with a CUF rating of 5 must roll a 3-6 in order to act freely ( $5/2 = 2.5$ , rounded up to 3).

BRDM-2

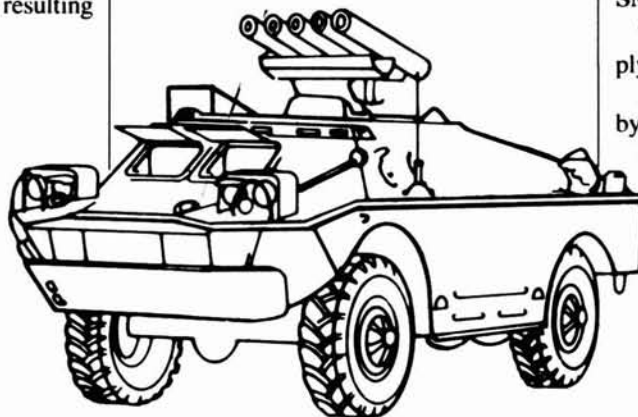

## NON-PLAYER CHARACTERS

**Last Battle** uses the same troop quality ratings as **Twilight: 2000**, so a Veteran NPC is still a veteran troop in **Last Battle**. The setup of **Last Battle** makes it very easy, then, to deal with mass combat: Simply record which NPCs are what troop level and then treat them accordingly as you play **Last Battle**.

## VEHICLES

The following are *guidelines* for transferring other vehicles from **Twilight: 2000** into **Last Battle**. Remember that **Last Battle** is meant to be a fun and quick way to play out **Twilight: 2000** encounters: all the fun without the bookwork.

**Armor:** Divide the armor rating for a particular area of a vehicle by 10. Use the C: TF, R: TF, and L: TF ratings to determine the armor on the left front, front, and right front of the vehicle's turret.

**Heavy Weapons and Artillery:** To determine the damage at Medium range for any antiarmor weapon (those listed with damage multipliers on the Referee's Charts in **Twilight: 2000**), multiply its Damage rate by 2. If the Damage rate has a "C" next to it, however, leave the number as it is.

To determine the damage that HE rounds do against troops, multiply the ROF by the Burst and divide by 10 ( $(ROF \times Burst) \div 10$ ).

To determine the weapon range, divide by 25.

**Movement:** **Last Battle** map hexes represent a distance of 50 meters. Divide the **Twilight: 2000** Com Mov statistic by 10, rounding up.

## SMALL ARMS

The following conversion guidelines apply to small arms.

**Attack Strength:** Divide the ROF statistic by 2.

**Range:** Divide the RNG statistic by 2.

## UNIT STATISTICS AND POINT VALUES FOR SCENARIOS AND CAMPAIGNS

### TANKS AND LCVs

<i>Unit</i>	<i>Primary Weapon</i>		<i>Missile Attack</i>	<i>Missile Range</i>	<i>Movement</i>	<i>Point Cost</i>
	<i>Attack</i>	<i>Range</i>				
T-72/80	70	20	—	—	4/3	12
T-90	70	20	—	—	4/3	15
M1	60	20	—	—	5/4	15
M1A1	70	20	—	—	5/4	16
M1A2	70	20	—	—	5/4	17
Stingray	60	20	—	—	5/4	12
Leopard II	70	20	—	—	5/4	14
M60A4	60	20	—	—	5/3	10
BRDM-3	12	10	—	—	7/3	6
LAV-25	10	10	—	—	6/4A	6
LAV-75	30	16	—	—	6/4	8

### APCs

<i>Unit</i>	<i>Primary Weapon</i>		<i>Missile Attack</i>	<i>Missile Range</i>	<i>Movement</i>	<i>Point Cost</i>
	<i>Attack</i>	<i>Range</i>				
M113	—	—	—	—	4/3A	4
M113 ACCV A3	3	6	—	—	4/3A	5
BTR-70/80	4	6	—	—	6/3A	5
BMD-B	12	10	—	—	6/3A	6
BMP-B/C	12	10	35	60	5/3A	7
M2	10	10	30	60	5/4A	7

### TROOPS AND PORTABLE WEAPONS

<i>Unit</i>	<i>Antipersonnel</i>		<i>Antivehicle</i>		<i>Movement</i>	<i>Point Cost</i>
	<i>Attack</i>	<i>Range</i>	<i>Attack</i>	<i>Range</i>		
1-man pistol	1/2	0	—	—	2	1/4
1-man assault rifle	1	2	—	—	2	1
1-man submachinegun	1	1	—	—	2	1/2
1-man shotgun	1	0	—	—	2	1/2
1-man rifle	1/2	3	—	—	2	1/2
Tankbreaker	—	—	30	80	—	4
AT-4	—	—	30	80	—	4
TOWII	—	—	40	140	—	4
Armburst	—	—	20	4	—	3
RPG-16	—	—	25	6	—	3
Mark-19	6	8	5	8	—	2
AGS-17	3	6	2	6	—	2
M60	2	5	—	—	—	2
M2HB	2	6	3	6	—	2

### HELICOPTERS

<i>Unit</i>	<i>Primary Weapon</i>		<i>Missile Attack</i>	<i>Missile Range</i>	<i>Troops Carried</i>	<i>Point Cost</i>
	<i>Attack</i>	<i>Range</i>				
Mi-17 Hip	—	—	15	16	34/20	20

### SOFT VEHICLES

<i>Unit</i>	<i>Primary Weapon</i>		<i>Missile Attack</i>	<i>Missile Range</i>	<i>Movement</i>	<i>Point Cost</i>
	<i>Attack</i>	<i>Range</i>				
HMMWV	—	—	—	—	7/4	3
HMMWV FSV	10	10	—	—	7/4	5
Truck	—	—	—	—	6/3	3
FAV	—	—	—	—	8/3	3
UAZ-469	—	—	—	—	7/3	3



# COMBAT AND MAP TABLES

## MODIFIERS TO SPOTTING

Condition	Modifier
Novice	-1
Experienced	0
Veteran	+1
Elite	+2
Spotting a Vehicle	+1
Spotting From a Vehicle	-1

*Note:* The above modifiers are to the number needed to roll. Thus, an Elite troop trying to spot a enemy unit 4 hexes away would need to roll a 4 or less (2+2).

## ATTACK MODIFIERS

Condition	Modifier
Novice	-1
Experienced	0
Veteran	+1
Elite	+2
Firing into rubble	-1
Firing into woods	-1
Firing into town	-1

## VEHICLE COMBAT RESULTS TABLE (VCRT)

Die	1:3	1:2	2:3	1:1	3:2	2:1	3:1	4:1	5:1
1	MIN	MIN	MAJ	MAJ	MAJ	MAJ	X	X	X
2	NE	MIN	MIN	MIN	MAJ	MAJ	MAJ	X	X
3	NE	NE	MIN	MIN	MIN	MAJ	MAJ	MAJ	X
4	NE	NE	NE	MIN	MIN	MIN	MAJ	MAJ	MAJ
5	NE	NE	NE	NE	MIN	MIN	MIN	MAJ	MAJ
6	NE	NE	NE	NE	NE	MIN	MIN	MIN	MAJ

An NE result means that the shot was reflected or absorbed by the armor—there is no further result. On a MIN result, roll a die on the defending vehicle's minor damage table (keeping in mind whether the shot was against the body or turret) and implement the results there. On a MAJ result, consult the vehicle's major damage table (either for the body or turret) and implement that result. An X result destroys the vehicle entirely. (See Escaping From Destroyed Vehicles.)

Any result other than NE against a Tread or Wheel means that the vehicle is immobilized for the remainder of the game.

## SPOTTING









Range (in hexes)	1	2	3	4
Roll*	A	4	3	2

A: Automatic spot.  
\*: Roll this number or less on one die to spot.

## MORALE POINT LOSSES

Unit Type	Morale Points
Leader	3
One Infantryman	1
Soft Vehicle	4
Armored Vehicle	6

## TERRAIN EFFECTS CHART

Terrain Type	Movement Costs	Combat Effects	Line-of-Fire Effects
 Clear	1 MP	No effect	No effect
 Woods	2 MP	-1 to number needed to hit	Blocks LOF through hex
 Town	2 MP	-1 to number needed to hit	Blocks LOF through hex
 Rubble	2 MP	-1 to number needed to hit unit in rubble	
 Building	1 MP to enter	-1 to number needed to hit +1 when firing from building	Blocks LOF through hex
 Road	1 MP	No effect	No effect
 Trail	1 MP	No effect	No effect
 Bridge	1 MP	No effect	No effect
 River	3 MP	Impassable except at bridge or by amphibious vehicle	No effect

## ELEVATION CHART

Color	Level
Green	0
Dark Green	1
Medium Brown	2
Dark Brown	3

A unit is considered to be on the highest terrain in the hex it occupies.

## ANTIARMOR WEAPON RANGE EFFECTS

Range	Distance	Strength
Close	1/2 or less	×2
Medium	Equal or less	×1
Long	Twice or less	×1/2
Extreme	Four times or less	×1/4

*Note:* Round all fractions up when calculating distance and attack strengths.

## ABBREVIATIONS

MF—Movement Factor  
FAV—Fast Attack Vehicle  
MBT—Main Battle Tank  
APC—Armored Personnel Carrier

# LAST BATTLE™

## Scenarios Book



Since 1973



# FIRST BATTLE

series game from GDW

# Last Battle Scenarios

This book contains nine predesigned scenarios. They are roughly divided by complexity, with the quickest and easiest scenarios appearing first. Thus, the earlier scenarios do not deal with morale and fire support, but the later ones do. These scenarios should make you familiar enough with the **Last Battle** rules that you can go on to design your own interesting scenarios.

These scenarios are based upon previously released **Twilight: 2000** modules. The name of the scenario is the same as the module it was adapted from. Each scenario describes a battle for survival in the post-holocaust society of WWII. Small, isolated groups clash, bringing only their experience and their few remaining weapons to bear on their enemy, hoping that this battle will be their last.

## LAST BATTLE™

### Credits

*Design:* Tim Ryan

*Development:* Frank Chadwick

*Scenario Design:* Loren K. Wiseman and Tim Ryan

*Cover Art:* A. C. Farley

*Art Direction:* Dana Reischauer

*Graphic Design and Production:* Christine Foreman

*Text Manager:* Michelle Sturgeon

*Text Processing:* Julie Amdor and Julia Martin

### Last Battle

Copyright©1989 GDW, Inc.

All rights reserved.

Printed in USA. Made in USA.

ISBN 1-55878-017-3.



PO Box 1646  
Bloomington, IL 61702-1646

### SCENARIO FORMAT

**Last Battle** is played in scenarios that list the forces of each side and their victory conditions. All the scenarios in this booklet follow the same format for ease of play.

#### Scenario Title

Each scenario begins with a title and a short introduction, which explains the background of the battle.

**Maps:** The specific maps to be used and how they should be combined are indicated.

**Objective:** The objective is a concise declaration of what each side is trying to accomplish.

**Initial Conditions:** This statement tells which side is the attacker and which side must set up first.

**Special Rules:** This statement indicates any special rules and rules which are not covered in the rules booklet. These rules are usually unique to the scenario, but you should feel free to include any appropriate special rules in the scenarios which you create.

**Scenario Length:** This statement tells the maximum number of game-turns that the scenario will last. When the deadline is reached, the scenario ends, and victory is determined. The scenario may end early if one side achieves its victory conditions. If a scenario length is listed as variable, then the scenario has no time constraint.

#### Defender

This section of the scenario identifies which side in the conflict is the defender, and it gives all the information that the defending player needs.

**Defending Forces:** This section indicates the color of the troop counters that the defending player is to use. The vehicles listed may or may not be the same color of counter. Also included is precise information about the defending forces, such as their types, numbers, and quality.

**Defender Fire Support:** This statement provides information about any available artillery.

**Defender Morale:** This section provides the hesitation point and the break point for the defender.

**Defensive Setup:** This section indicates where defensive units may initially be placed on the maps and what restrictions apply.

#### Attacker

This section identifies which side in the battle is the attacker and provides pertinent information for the attacking player.

**Attacking Forces:** This section identifies the color of the troop counters which the attacking player uses. Any vehicles listed here may be a different color. This section also lists specific forces, their numbers, and their quality.

**Attacker Fire Support:** This section provides information about any available artillery.

**Attacker Morale:** This section provides the hesitation point and break point for the attacking forces.

**Attacker Setup:** The section indicates where on the maps the attacking forces may be initially placed. It also includes any restrictions for that setup.

#### Winning

This statement indicates exactly what the attacking player must accomplish in order to obtain a victory. If the attacking player does not succeed (does not meet the requirements listed here), then the defender wins.

LAV-25

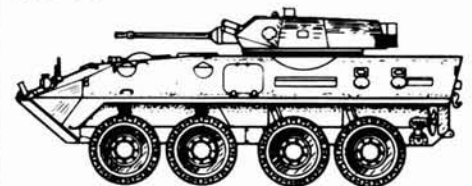

**New York City, New York**

Fighting in war-torn Poland or picking your way through the rubble that was Paris is one thing, but coming home, coming back to the United States, and seeing the same destruction, poverty, and chaos here is overwhelming.

New York City was hit by two nuclear bombs in late 1997. The streets of New York have always been dangerous, but hunger, war, and the lack of government have transformed the entire city into a battlefield.

**Maps:**

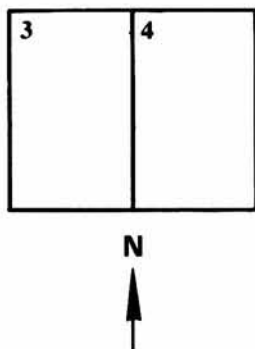

**Objective:** The *Los Diablos* gang player must eliminate the US Army player's forces.

**Initial Conditions:** The *Los Diablos* player attacks and has initiative. The US Army player sets up first, anywhere on map 3.

**Special Rules:** Any force which leaves the board is automatically eliminated.

**Scenario Length:** Variable.

**Defender: US Army**

The US government has sent you on a reconnaissance mission. You must assess what measures should be taken to restore law and order to New York City.

**US Army Forces:** Green counters. Veteran: 15 troops (9 AR, 2 SMG, 3 PST, 1 Rifle). One leader.

**US Army Morale:** Hesitation point is 9; break point is 13.

**US Army Setup:** Anywhere on map 3.

**Attacker: Los Diablos Gang Members**

The US government has done nothing for you. Your city was nuked, and hundreds of thousands of people were killed—many more still starve to death. And now there are rumors that the government wants control of the city. For what purpose you wonder—to start another war?

**Los Diablos Forces:** Brown counters. Experienced: 24 troops (16 PST, 4 SG, 2 Rifle, 2 SMG). 1 leader.

**Los Diablos Morale:** Hesitation point is 10; break point is 20.

**Los Diablos Setup:** Anywhere on map 4.

**Winning**

The *Los Diablos* player wins by destroying all the US Army player's forces.

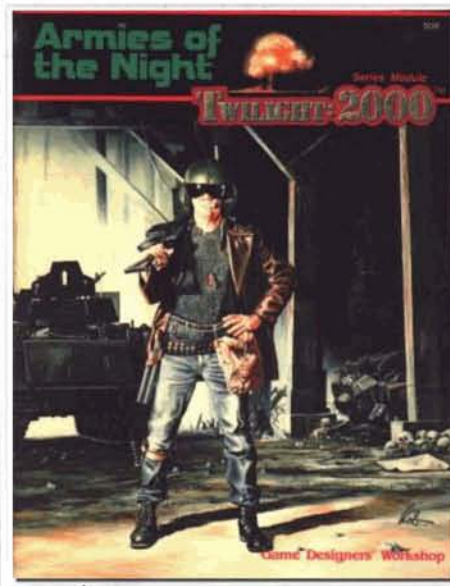

# 1 Armies of the Night

**Mauser Mark X**



**AK-74**

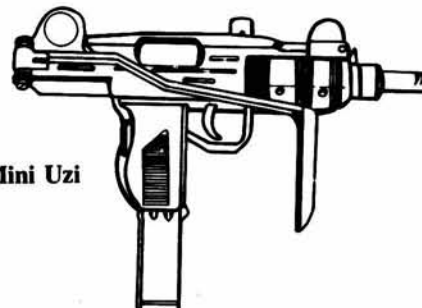

**Mini Uzi**

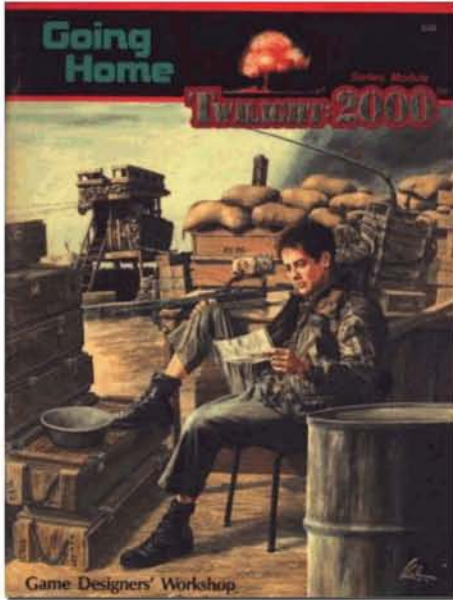

## 2 Going Home

### Neutral Zone, France

The war in Europe has been bloodier and more destructive than any in history. Army headquarters on all sides were destroyed, resulting in the fall of entire governments and countries. Many of the US soldiers fighting the war in Europe have grown accustomed to spending each day selecting their own operations, simply staying alive being high on the list of priorities.

Wandering around Europe with incomplete and now out-of-date maps, trying to hook up with more American soldiers, and having to scrounge for food at every turn has left many soldiers tired, demoralized, and dangerously apathetic. Apathetic, that is, until what's left of SACEUR (the Supreme Allied Command, Europe) decided to evacuate all American forces from Europe.

The German government has agreed to cooperate with the American troops and has arranged for a ragtag fleet to ship the soldiers home. But the strain of tens of thousands of American troops travelling across the European countryside to get to Germany has ruined many cities. The soldiers take what they need as they pass, only thinking about making it to that ship; meanwhile, local citizens are being robbed of the supplies they will need to weather the coming winter. Many European citizens are flocking to the biggest cities for supplies and for protection.

Some of the US troops must cross the French "dead zone," an area that French troops patrol in order to keep marauders and refugees out.

#### Maps:

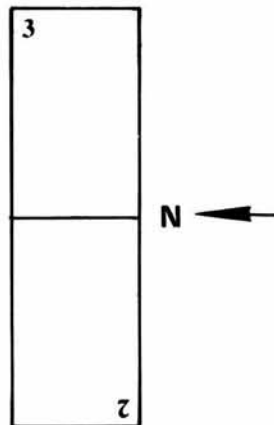
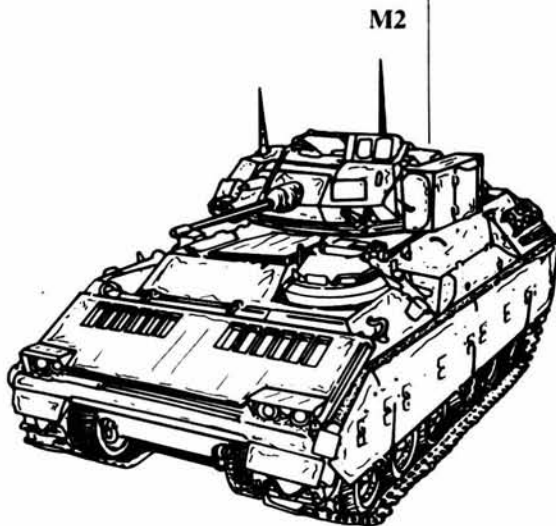

**Objective:** The US player must exit the east side of map 3.

**Initial Conditions:** The US attacks and has the initiative. The French set up first.

**Scenario Length:** Variable.

### Defender: France

In order to survive the winter and begin to rebuild your country, you must not let anyone cross the dead zone into France.

**French Forces:** Green counters. 3 GPMG, 1 Tankbr. Veteran: 20 troops (16 AR, 4 PST). Experienced: 18 troops (13 AR, 5 PST). 2 leaders.

**French Fire Support:** None.

**French Morale:** Hesitation point is 20; break point is 32.

**French Setup:** Anywhere on map 3.

### Attacker: US

You must cross the French dead zone with all haste in order to make it to Germany and the fleet which will take you home.

**US Forces:** Brown counters. 1 M2, 2 FAVs, 1 HMG. Elite: 8 troops (6 AR, 2 SMG). Veteran: 12 troops (8 AR, 3 SMG, 1 PST). Trained: 10 troops (3 AR, 3 Rifle, 2 SMG, 2 PST). 2 leaders.

**US Fire Support:** None.

**US Morale:** Hesitation point is 20; break point is 32.

**US Setup:** Not more than three hexes from the west edge of map 2.

### Winning

The US player gets 1 point for every man he gets across the dead zone (the east edge of map 3). The French get 1 point for every man destroyed and 6 points if they have not fired their Tankbr by the end of the scenario. The player with the highest score wins.

**Allegheny Mountains, Western Pennsylvania**

The US government has split into two primary factions: MilGov (the military government) and CivGov (the civilian government). The CIA, a branch of CivGov, has extensive plans for reintegrating what's left of the American population under its banner. But to do this, the CIA needs supplies: computers, medical supplies, grain, clothing, and, of course, endless records and files of bureaucratic data.

The CIA is convinced that it knows where these things can be obtained. It has information on a secret cache, Strategic Reserve Stockpile 17374-2. Unfortunately, however, SRS 17374-2 is located in the Allegheny Mountains, the site of a tremendous clash between CivGov and MilGov, and also the site of tremendous marauding units called the Allegheny Warlords.

The CivGov agents are charged with the task of finding SRS 17374-2, examining the cache's contents, and radioing the report back to a column of CIA troopers who stand a few miles off. If the CivGov agents find the cache but are being attacked by enemy troopers, the agents can call in the CIA troops, who will arrive in minutes.

A small band of the Allegheny Warlords spots the CivGov agents as they enter the warlord's territory. Guessing that they must be after something important, the warlords wait for an opportune moment and then attack.

Players should agree before setup as to which hex will represent the cache. The hex must be on map 2 in the woods.

**Maps:**

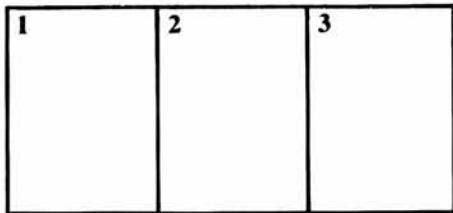

**Objective:** The Allegheny Warlords player must not allow the CivGov player to examine the contents of SRS 17374-2 and radio a report back to the CIA agents. For the CivGov player to succeed, he must have at least one unit (of at least two men) spend two consecutive turns on the cache. After that, you will find the cache full of valuable items, radio for the CIA agents, and be relieved.

**Initial Conditions:** The Allegheny Warlords attack and have the initiative. The CivGov player must set up first, with no unit closer than 10 hexes to the cache.

**Scenario Length:** Variable.

**Defender: CivGov**

A quick, quiet trip is what you had hoped for, but then the Allegheny Warlords arrived.

**CivGov Forces:** Brown counters, 3 HMMWVs, 1 truck, 2 FAVs, 1 HMG, 2 GPMG. Veteran: 22 troops (12 AR, 4 SMG, 3 PST, 3 Rifle). 2 leaders.

**CivGov Fire Support:** None.

**CivGov Morale:** Hesitation point is 16; break point is 38.

**CivGov Setup:** Anywhere on map 3.

**Attacker: Allegheny Warlords**

If CivGov is really onto something, it could be worth a fortune to you on the black market.

**Warlord Forces:** Green counters, 1 BMP-B/C, 1 truck, 2 HMMWVs, 1 GPMG. Elite: 14 troops (8 AR, 3 SMG, 2 Rifle, 1 PST). Trained: 13 troops (7 AR, 3 SG, 2 SG, 1 Rifle). 1 leader.

**Warlord Fire Support:** 1 82mm.

**Warlord Morale:** Hesitation point is 12; break point is 26.

**Warlord Setup:** All units must set up on map 1.

**Winning**

The warlords win if they can destroy (or drive off) the CivGov agents before they have time to examine the cache and call for reinforcements. Once the reinforcements are called, it's all over.

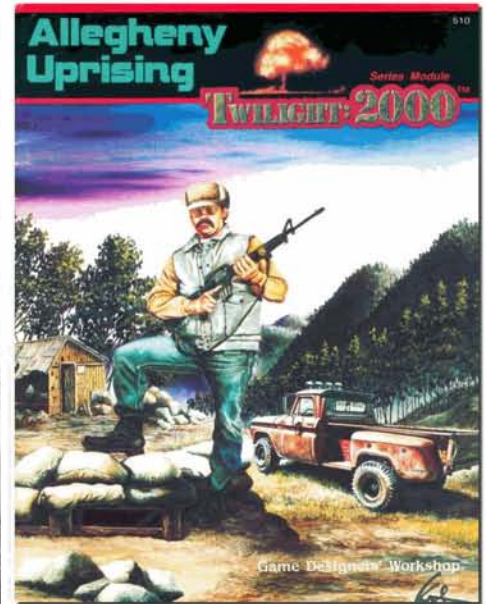

# 3 Allegheny Uprising

BMP-A

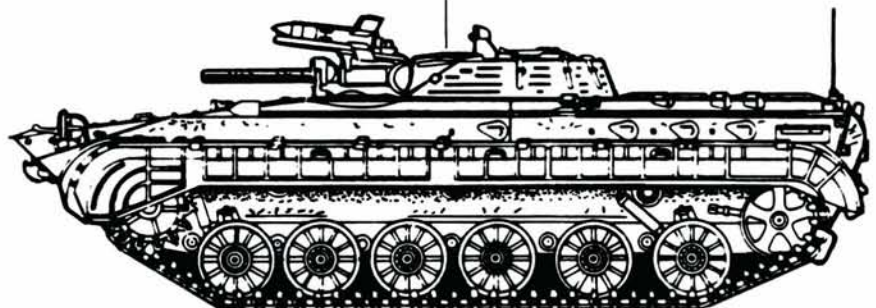



## 4 Airlords of the Ozarks

### Ozark Mountains, Tennessee

Repeated rumors of marauders in the Ozark region have come to the attention of CivGov. The marauders, calling themselves the "Airlords of the Ozarks," obtained several dirigibles and have been harrying the countryside, looting and destroying whatever they come upon. CivGov agents were sent to assess the strength and precise whereabouts of the marauders, then return to CivGov headquarters.

The CivGov agents infiltrated one of the marauder bases and got the information they were sent to obtain, but they were careless as they withdrew. The marauders have been alerted and are pursuing the CivGov agents through the Ozark Mountains.

#### Maps:

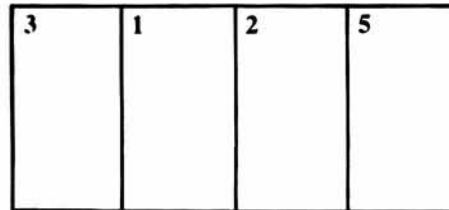

M113

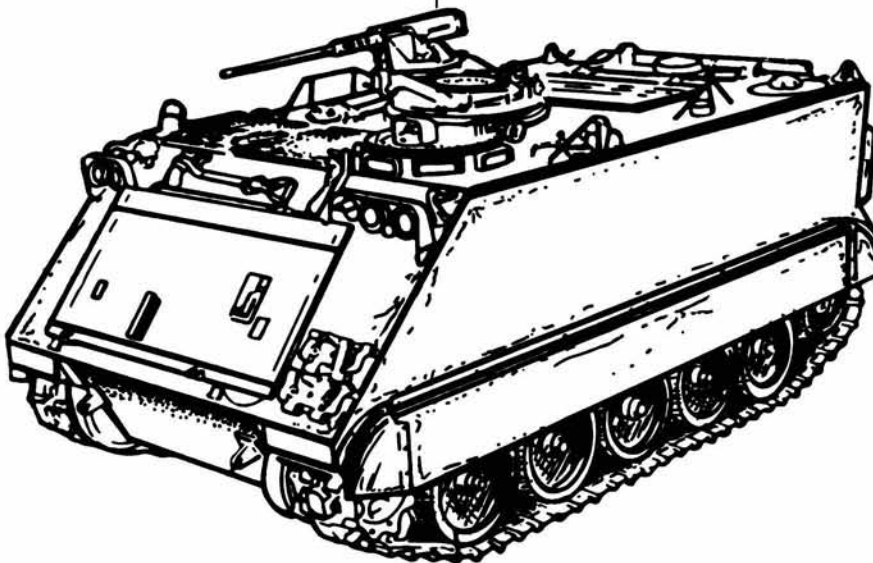

**Objective:** The Airlords player must stop the CivGov agents from escaping off the east edge of map 5.

**Initial Conditions:** The Airlords player is the attacker and has the initiative. The CivGov player sets up first.

**Special Rules:** There is a bridge counter on map 5. This scenario takes place at night.

**Scenario Length:** Variable.

#### Defender: CivGov Agents

Having obtained the information you need, you must get back to CivGov headquarters.

**CivGov Forces:** Green counters. 1 M113, 2 HMMWVs. Elite: 4 troops (2 Rifle, 1 AR, 1 SMG). Veteran: 6 troops (4 AR, 1 SG, 1 PST). Trained: 4 troops (2 PST, 1 SMG, 1 AR). 2 Leaders.

**Fire Support:** None.

**CivGov Morale:** Hesitation point is 10; break point is 24.

**CivGov Setup:** On map 1, no more than 2 hexes from the west edge.

#### Attacker: Airlords of the Ozarks

Agents of the defunct government have meddled one too many times in your business. This time they have entered your camp at night and spied on your operations. Teach them a lesson now!

**Airlords Forces:** 2 FAVs, 1 HMMWV, 1 M113, 1 truck. Veteran: 6 troops (3 AR, 2 Rifle, 1 PST). Trained: 20 troops (8 PST, 4 SG, 6 Rifle, 2 SMG). 2 Leaders.

**Fire Support:** None.

**Airlords Morale:** Hesitation point is 18; break point is 30.

**Airlords Setup:** Anywhere on map 3, but no closer than six hexes to any CivGov force.

#### Winning

The CivGov player gets 4 points for every vehicle which exits the map and 1 point for every man who exits. The Airlords player gets 1 point for every enemy man killed and 4 points for every immobilized or destroyed vehicle.

### Corpus Christi, Texas

A Mexican kingpin named Navarro and LaMarr, an ex-marauder, have been slowly pushing their sphere of influence into Texas. Their mobility has been seriously limited, however, by their lack of fuel. They hit upon the idea of trying to restart one of the off-shore oil drilling platforms located 40 kilometers off the shore of Brownsville, Texas. Since they didn't have the technical expertise, they kidnapped someone who did—a man named Bill Bob Kingsley. Navarro and LaMarr also took Kingsley's wife, Kathy Jean, and are holding her hostage to ensure her husband's cooperation. The two are being kept in Brownsville.

The rumor of oil in Brownsville has leaked out: it has attracted the attention of a fairly large and well armed Soviet detachment, which plans to attack Navarro in Brownsville. It is scheduled to arrive in Brownsville at 0900 hours (9:00 a.m.).

At 0900, Navarro will send a message to LaMarr in Corpus Christi ordering him to take all his men and get to Brownsville to help repel the attack.

LaMarr's base is the demolished ruins of the Corpus Christi Air Station, once the possession of the US government. LaMarr has Kathy Jean thrown in with 40 other prisoners. During the day these people work to clear the rubble at LaMarr's base.

A small group of US soldiers has been hired to attack LaMarr's base to ensure that he does not relieve Navarro during the Soviet attack. Several Texans volunteered to join the troops.

#### Maps:

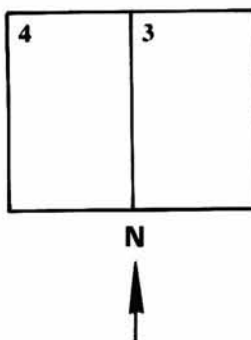

**Objective:** The US player must break LaMarr's morale and receive his surrender by 0900.

**Initial Conditions:** The US player is the attacker and has the initiative. The Mexican player sets up first.

**Special Rules:** If the Mexican player's morale reaches break point, he will surrender to the American soldiers (instead of retreating). The Mexicans may not begin the game with any troops or crew in the vehicles, and may not board the vehicles until attacked. Crew boarding a vehicle costs 1 MP, the same as for troops.

The mortars must be placed inside the city hexes.

**Scenario Length:** 15 turns.

#### Defender: Mexicans

Unaware of the Soviet advance on Brownsville and the US rescue mission, you are not expecting any problems.

**Mexican Forces:** Green counters. 2 M113s, 1 M1A1 (RF+1), 1 LAV-75. Trained: 30 troops (6 PST, 2 SG, 4 SMG, 4 Rifle, 14 AR). Novice: 12 troops (5 PST, 6 AR, 1 SG). 2 leaders, 4 dummies.

**Fire Support:** 1 82mm mortar and 1 120mm mortar, with 20 salvoes of HE total.

**Mexican Morale:** Hesitation point is 24; break point is 50.

**Mexican Setup:** Any city hexes.

#### Attacker: US

Mechanical difficulties delayed your arrival: You have less than 10 minutes to make your attack effective!

**US Forces:** Brown counters. 2 FAV, 1 HMMWV with TOWII, 1 M2, 1 M1, 1 Stingray. Veteran: 9 troops (4 AR, 4 SMG, 1 PST). Novice: 45 troops (7 SG, 8 Rifle, 12 PST, 5 SMG, 13 AR). 4 leaders.

**US Fire Support:** None.

**US Morale:** Hesitation point is 30; break point is 68.

**US Setup:** In any hills or woods hexes, at least 5 hexes from the nearest Mexican unit.

#### Winning

The US player wins if the Mexicans reach break point by the end of the 15th game-turn.

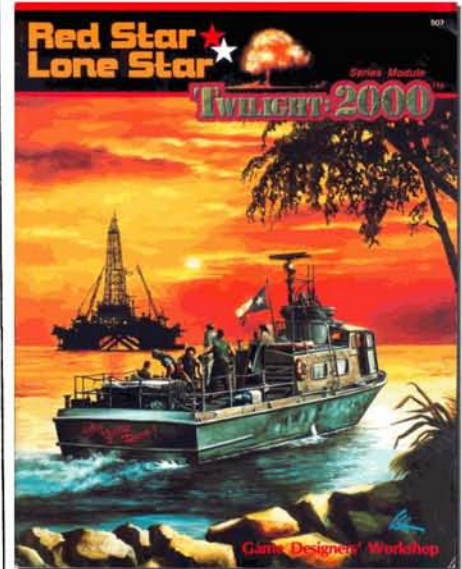

## 5 Red Star/ Lone Star

TOW II

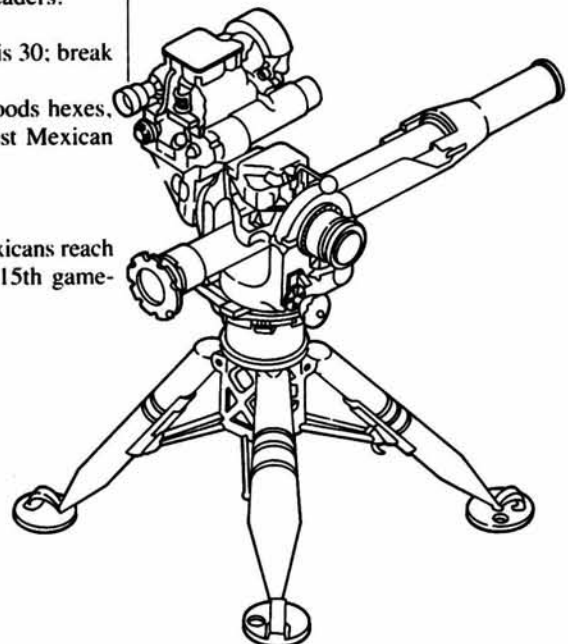



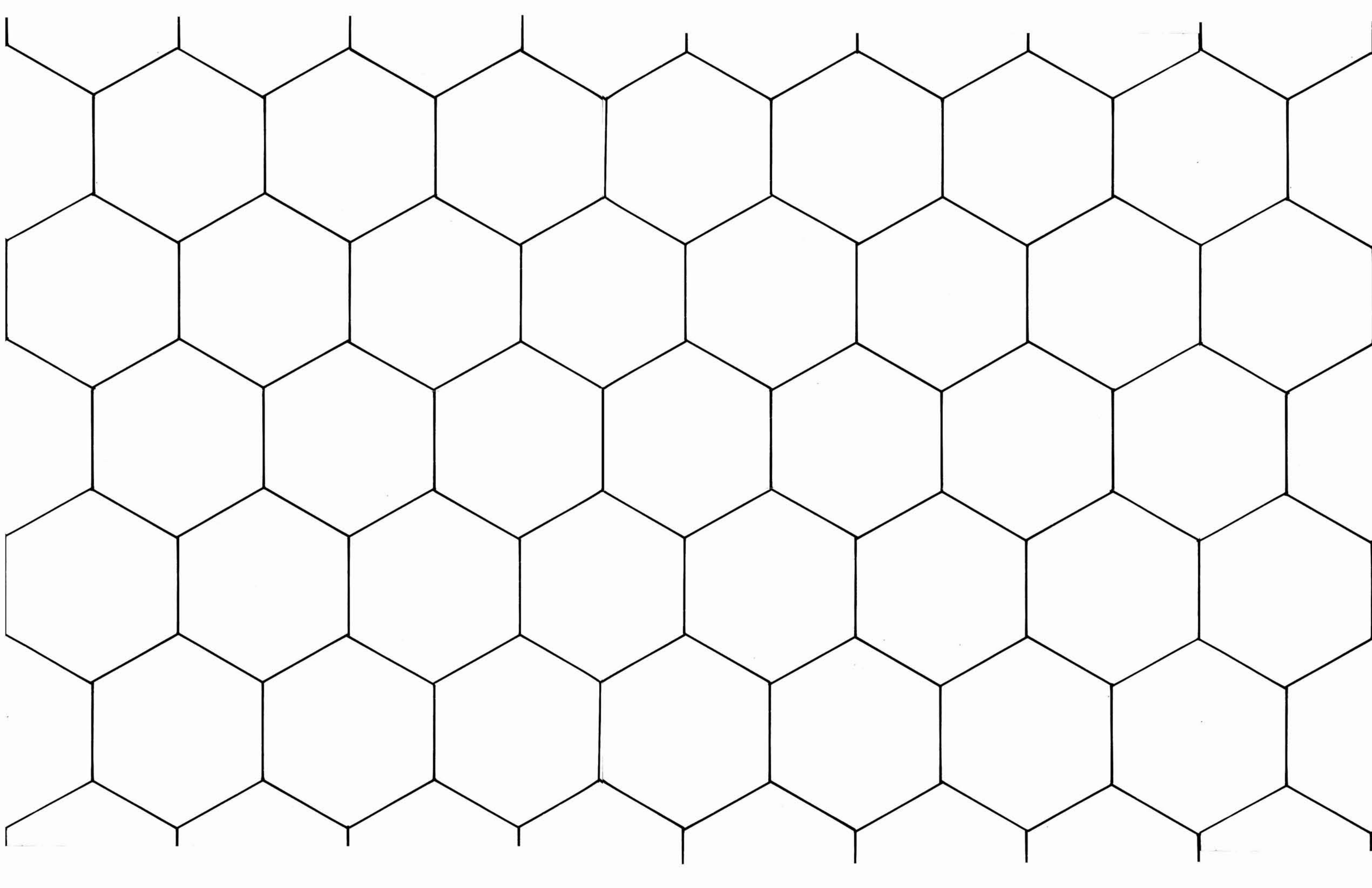



## 6 Red Star/ Lone Star

### Harlingen, Texas

A Soviet column from *Division Cuba* in San Antonio is seeking to seize control of one of the few remaining active oil wells in the country. To do this, they must pass through Harlingen. If the Soviets gain control of a producing oil well, their hold on San Antonio will be greatly strengthened, and they will be 10 times harder to dislodge from that city. In addition, they will be tremendously furthered in their attempts to conquer a seaport and escape back to the USSR.

#### Maps:

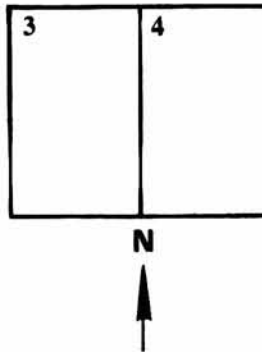

BTR-70

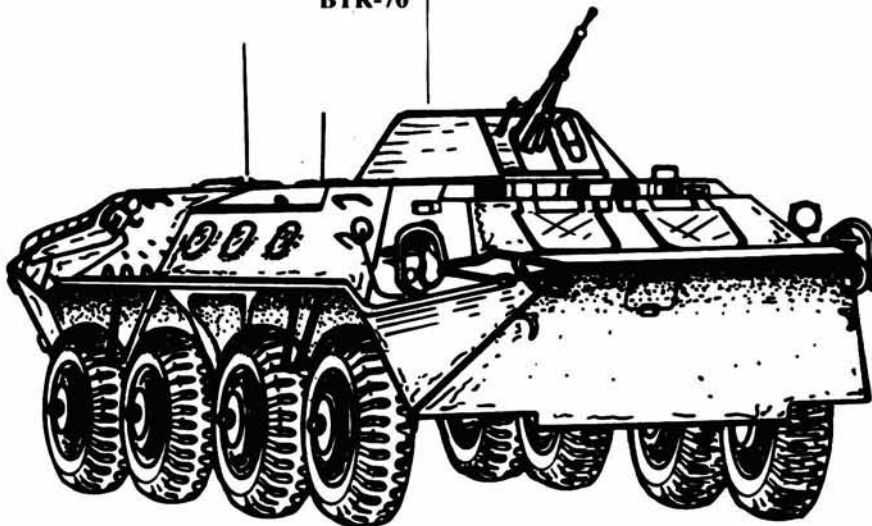

**Objective:** The Soviet column must get through Harlingen to get to the oil field beyond, without taking too many casualties. The Texans must stop them.

**Scenario Length:** Variable.

#### Defender: Texan Forces

The defenders are a scratch collection of ex-soldiers, ranchers, and other civilians thrown together to prevent the Soviet forces from getting through the city of Harlingen.

**The Texan Forces:** Green counters. 1 truck, 1 ATGM, 4 horses. Trained: 14 troops (6 AR, 2 PST, 6 Rifle). 1 leader. The ATGM is carried aboard the truck but cannot be fired from it. It also has limited ammunition, and can only be fired twice.

**Texan Forces Morale:** Hesitation point is 7; break point is 12.

**Texan Forces Setup:** Anywhere in the city of Harlingen or within two hexes of it.

#### Attacker: Soviet Forces

The attacking force consists of a flying column from the Soviet *Division Cuba* in San Antonio.

**The Soviet Forces:** Brown counters. 2 trucks, 2 UAZ-469s, 1 BTR-70, 2 HMG. Veteran: 16 troops (12 AR, 4 PST). 1 leader.

**Soviet Morale:** Hesitation point is 10; break point is 20.

**Soviet Setup:** The Soviet forces must enter on the west side of map 3, within one hex of the trail.

#### Winning

The Soviets win if they exit at least three vehicles and two-thirds of their initial personnel off the east edge of the map 4 (within one hex of the road). The Texans win if they prevent the Soviets from winning.

**Tushkuyeh, Iran**

An American infantry team is performing a long-range reconnaissance mission when it encounters an exceptionally large party of hostile *Tudeh* guerrillas. Since the American force is not intended to engage and destroy the guerrillas, it must escape with minimum casualties (although any casualties it manages to inflict on the guerrillas will be a good thing) and report the encounter to its chain of command.

In order for their presence to remain unknown for as long as possible, the guerrilla forces must prevent the Americans from escaping with word of their approach.

**Maps:**

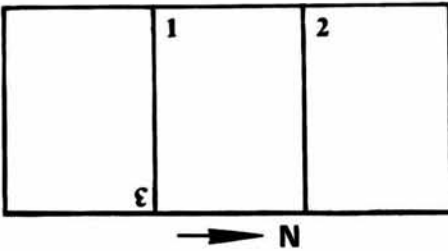

**Colt Combat Commander**

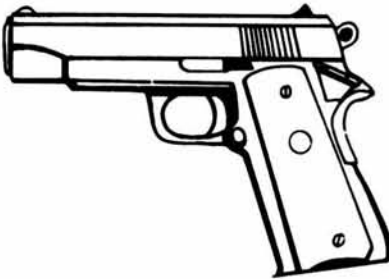

**Objective:** The American party must elude the *Tudeh* guerrillas and escape with minimal casualties of the north edge of map 2 within two hexes of the east edge. The *Tudeh* guerrillas must prevent the Americans from carrying word of their approach to the allied high command.

**Scenario Length:** Variable.

**Defender: American Soldiers**

The defenders are a party of American soldiers, on a long-range recon patrol in the vicinity of the town of Tushkuyeh.

**The American Forces:** Brown counters. 2 trucks, 1 M113, 1 GPMG. Veteran: 11 troops (2 PST, 8 AR). 1 leader.

**American Forces Morale:** Hesitation point is 10; break point is 18.

**American Forces Setup:** Set up anywhere along the southern edge of map 3, more than two hexes from either the north or south edge.

**Attacker: Tudeh Guerrillas**

The attackers are a roving band of Soviet-backed *Tudeh* guerrillas, passing through the area of Tushkuyeh on their way to raid American installations to the southeast. Part of the guerrilla force is on horseback; part of it is carried in the group's one truck.

**The Tudeh Forces:** Green counters. 1 truck, 4 horses, 1 HMG. Trained: 20 troops (4 PST, 16 AR). 1 leader.

**Tudeh Morale:** Hesitation point is 8; break point is 16.

**Tudeh Setup:** Anywhere on maps 1 or 2, at least three hexes from the western edge.

**Winning**

The Americans win if they exit the board with at least 5 troops and no vehicles lost. The guerrillas win if the Americans do not meet their victory conditions.

**M16**



**M60**



**M2HB**

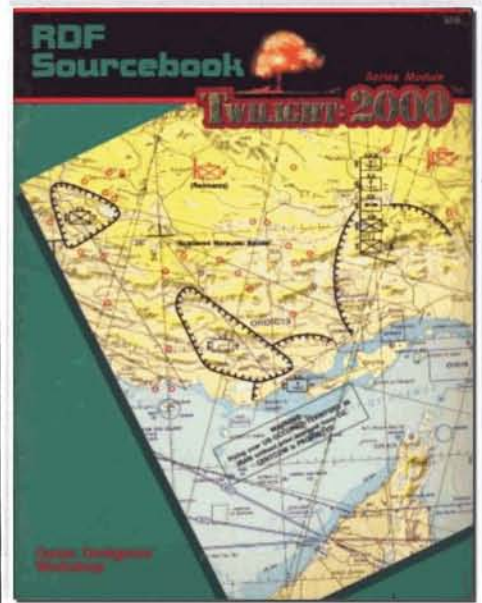
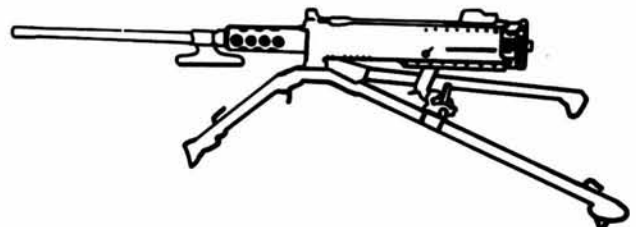

**7 RDF Sourcebook**



## 8 The Free City of Krakow

### Krakow, Poland

Krakow has declared itself a free city. Soldiers from all armies are welcome here as long as they do not carry on the war in Krakow. Soviet, American, and European soldiers are often seen side-by-side in Krakow, but their governments still carry on a silent and often deadly war inside the city.

To keep the peace, a policing unit was created called the ORMO. At the head of the ORMO is Dowodca Josef Kutrzeba. Although Kutrzeba was responsible for creating the ORMO and has successfully kept the city neutral, he is not doing it strictly for the good of Krakow. Kutrzeba's next step is to make himself the sole dictator as soon as possible.

The impact of this is hard to measure, and the likelihood of his success is difficult to gauge, but Kutrzeba is popular with the people of Krakow and worshipped by his personal guard.

Among his personal accomplishments are the ORMO, an ambitious rebuilding program for portions of the city, and the impounding of a Polish Army Mi-17 Hip Transport Helicopter. This helicopter's tremendous firepower and perfect working condition will go far in helping assure that Kutrzeba's ambitions are realized.

#### Maps:

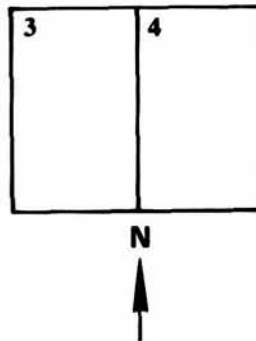

Laser Range Finder

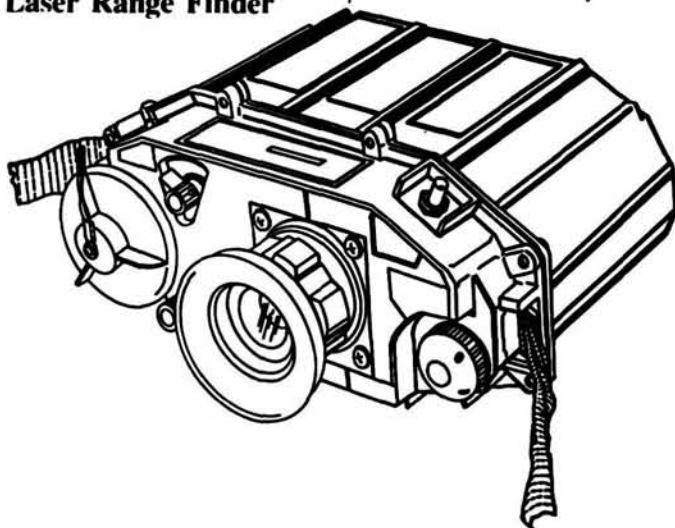

**Objective:** The US player must capture the helicopter and successfully fly it to nearby Tynec, where CIA agents are waiting.

**Initial Conditions:** The US player attacks and has the initiative. The Krakow player sets up first.

**Special Rules:** This scenario takes place at night. The Stingray has infrared sights. One of the US player's leaders is also a helicopter pilot. The US player must write down the ID number of the counter that represents the pilot. If the pilot is killed, the helicopter cannot be stolen. The Krakow player may not shoot at the helicopter until there are enemy troops aboard it. During the turn after the pilot is aboard, the helicopter may lift off. After the next turn it will be out of range.

**Scenario Length:** 12 turns.

### Defender: Krakow

You are Kutrzeba's personal guard. You would defend his property and serve him in any capacity possible.

**Krakow Forces:** Green counters. 2 82mm. Veteran: 14 troops (9 AR, 4 PST, 1 SG). Trained: 10 (5 AR, 2 Rifle, 2 PST, 1 SG). 2 leaders, 5 dummies.

**Krakow Fire Support:** 1 82mm, 1 4.2 inch.

**Krakow Morale:** Hesitation point is 12; break point is 21.

**Krakow Setup:** All Krakow troops must be set up within two hexes of the helicopter on map 4.

### Attacker: US

The CIA has sent you on a commando raid to steal the helicopter and turn it over to American forces.

**US Forces:** Brown counters. 1 Stingray (with infrared sights), 2 GPMG, 1 HMG. Elite: 8 troops (5 AR, 3 SMG). Veteran: 6 troops (3 SG, 3 AR). Trained: 10 troops (6 AR, 3 PST, 1 SMG). Novice: 10 troops (5 AR, 3 PST, 2 Rifle). 4 leaders.

**US Fire Support:** None.

**US Morale:** Hesitation point is 15; break point is 32.

**US Setup:** No closer than three hexes to the nearest Krakow unit.

### Winning

The US player wins if his pilot boards the helicopter and can fly it out of Krakow.

**Warsaw, Poland**

The Baron has taken control of Warsaw, but the people are ready to revolt. The Baron has a large piece of artillery—a D-30, 122mm howitzer—which he could use to quiet all those who oppose him. The D-30 can fire at targets up to 15 kilometers away. With some skill and a little luck, it could flatten four city blocks in about two minutes. But the Baron has one problem—he has no ammunition!

The Baron has sent his Black Guard in a convoy to Baranovic to obtain the ammunition that he needs. If he can get it within three days, he will be able to suppress any rebellion. If his attempt to obtain the ammunition is unsuccessful, he will be destroyed.

Polish rebels have received information about the convoy and have managed to elicit the help of several American troops in the area. When the American/Polish forces caught up with the Baron's convoy and saw its size, they realized that an ambush was their only hope. The Baron's convoy is within one kilometer of Baranovic when the rebels find him.

**Maps:**

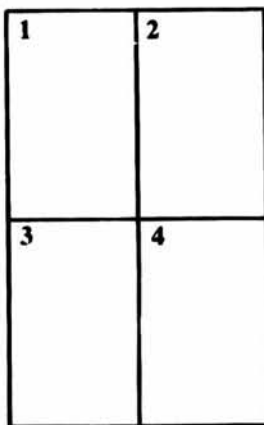

**Objective:** The US player must destroy the Baron's caravan before it can load the ammunition in Baranovic and escape back to Warsaw.

**Initial Conditions:** The US player has the initiative and must set up first. The Baron's forces may not leave the road until they are attacked.

**Scenario Length:** Variable.

**Defender: The Baron's Convoy**

Any one of your vehicles (except the T-72/80 and T-90) must spend two turns in Baranovic (the city on map 2) to load the ammunition before you can exit the south side of map 2 and win. No troops may be carried in the vehicle which transports the ammunition.

**The Baron's Forces:** Green counters. 1 T-90, 1 T-72/80, 1 BMD, 2 BMP-B/Cs, 2 trucks, 2 GPMG, 1 HMG. Veteran: 34 troops (21 AR, 2 SG, 8 PST, and 3 SMG). Three leaders.

**The Baron's Morale:** Hesitation point is 35; break point is 70.

**The Baron's Setup:** Anywhere along the road on map 4.

**Attacker: Americans and Polish Rebels**

Thinking the Baron a ruthless dictator, the rebels have vowed to stop him at any cost.

**Rebel Forces:** Brown counters. 1 M1A2, 1 M2, 1 M113, 1 AT-4, 1 Tankbr, 1 HMG. Trained: 28 men (21 AR, 3 PST, 3 SG, 1 SMG). 3 leaders.

**Rebel Morale:** Hesitation point is 20; break point is 40.

**Rebel Setup:** Anywhere except map 4.

**Winning**

The Rebel team wins if it can destroy all vehicles in the convoy before it exits the south side of map 2.

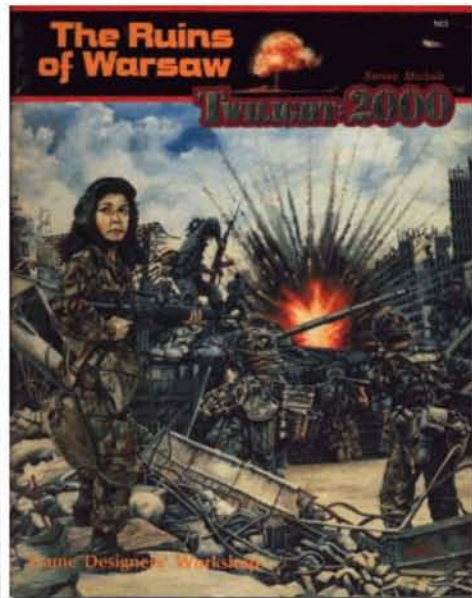

# 9 The Ruins of Warsaw

T-72

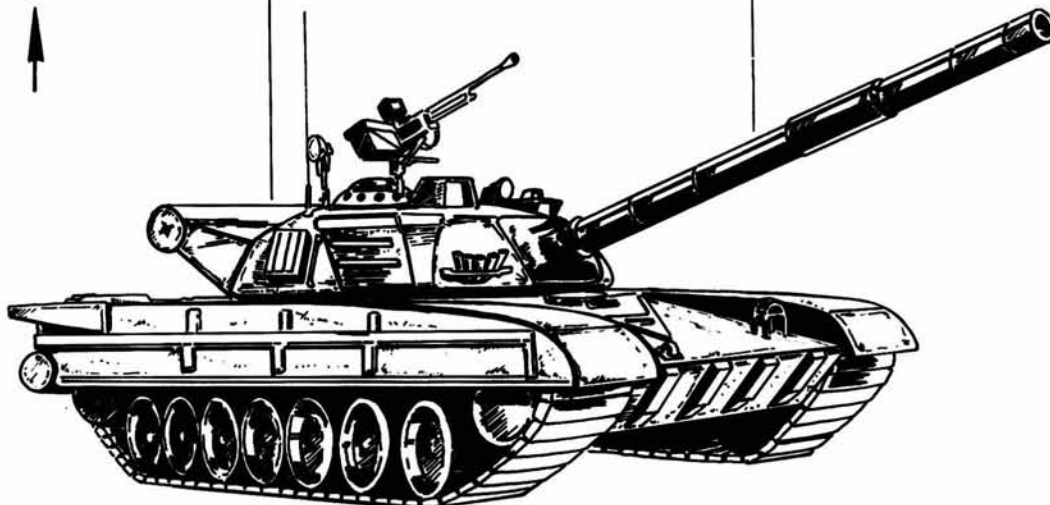

# Designing Your Own Scenarios

Once you have played and mastered the scenarios included in the game, you may want to go on to fight other battles. The maps and counters from **Last Battle** can be used to fight a wide variety of scenarios. Use the maps in the game to get as close an approximation of the terrain as you can manage and then select units from the counter mix that represent the opponents.

Creating scenarios for hypothetical battles is fun because it enables you to experiment with different approaches to raising and organizing an army. In effect you are designing your own military force, deciding its organization, leadership, troop quality, and how it will be equipped. You will then match it against your opponent's force. While it is impossible to design scenario rules which encompass the full diversity of situations possible, these rules do provide useful guidelines for laying out battles in an even-handed and interesting manner.

## 1. SIDES

Both players should agree which color pieces they will use to represent their troops. Players should then decide which player will be on the defensive and which will attack. If players cannot agree, each should roll a die. High die roll picks color, and the other player picks attack or defense.

## 2. MAP

Players should decide on the map or maps used. If they cannot agree, the attacker will pick the maps and their configuration. The defender will then decide which half of the map he will defend.

## 3. SCENARIO SIZE

Players need to agree whether it will be a small, medium, or large scenario. If they cannot agree, roll a die with the high die roll deciding.

## 4. CHOOSE MISSIONS

Both sides secretly choose a mission and write it down. Each mission has an objective and three levels of asset points: The first is used in a small scenario, the second in a medium scenario, and the third in a large scenario.

### A. Attacker's Missions

The attacker generally has more points to spend per mission than does the defender.

**(1) Seize The Objective:** The attacker must seize either half the villages or half the hills on the defender's side of the map. The attacker must choose which of these options he will attempt prior to the start of the scenario and write them down. If there is an odd number, round the fraction up.

*Asset Points: 50/100/150*

**(2) Break The Front:** The attacker must exit the opposite board edge with at least half his force.

*Asset Points: 50/100/150*

**(3) Contain The Enemy:** The main effort is to be launched elsewhere. Your task is to engage the enemy with sufficient force to occupy his attention and prevent him from shifting troops elsewhere. To do this you must inflict sufficient losses to cause a hesitation result.

*Asset Points: 40/80/120*

### B. Defender's Missions

Because the defender can make better use of concealment, he has fewer points to spend than does the attacker.

**(1) Hold:** You must hold the important terrain features in your area and prevent significant enemy forces from exiting the map into your force's rear areas.

*Asset Points: 30/60/90*

**(2) Delay:** With a minimum of forces you must either prevent the enemy from exiting the board in strength, or you must inflict sufficient losses to cause a hesitation.

*Asset Points: 20/40/60*

### 5. PURCHASE ASSETS

Assets are the combat tools you will use to attempt to meet your objective. Although your real-life counterpart would not have this much latitude, for the sake of variety and game interest, you will be able to pick your assets, within limitations. Those limitations are the asset points provided in the mission description. All assets are purchased with these asset points.

### A. Ground Forces

Ground forces are purchased in individual vehicles and troops. The point cost of each unit is given in the section of these rules that discusses their capabilities.

### B. Troop Types

Troop point costs are given for Novice troops equipped with the weapon listed. Troops of a higher experience level cost additional amounts. Add ½ point per Experienced troop, 1 point per Veteran, 2 points per Elite, and 6 points per leader. (Remember that all leaders are counted as Elite.)

### C. Force Morale

Ground forces may be purchased with fair, good, or excellent morale. The difference is the point at which the units reach their hesitation point and their break point. All troops in a scenario must have the same morale level. If you intend to purchase troops as good troops, pay asset points equal to those in the Choose Missions section. To purchase them as fair troops, multiply your total asset point budget by 1.25. To purchase them as excellent troops, multiply your total asset point budget by 0.8.

To determine the hesitation point and break point of your force, first total up the morale points of your force. You do this by adding up the total number of pieces in your force and then adding 5 for every leader unit. (This makes each leader worth 6, one for the piece and an additional five for being a leader.) If your force is fair, multiply the total by 0.2 and by 0.4, rounding all fractions up. When total losses reach the first number, your force hesitates; when they reach the second number, your force breaks. If you have good troops, multiply by 0.3 and by 0.6 to determine hesitation and break levels. If you have excellent troops, multiply by 0.4 and by 0.8.

### D. Engineering Support

The following assets may be purchased:  
*Engineer-laid minefield:* 1 point.  
*Concealed engineer-laid minefield:* 3 points.

### D. Artillery Support

One off-map battery in support costs 5 asset points plus the cost listed below for the actual system used. Each additional battery costs only the amount listed below:

82mm: 5

4.2 inch or 120mm: 10

Artillery fire costs the following per salvo:

#### ARTILLERY FIRE COSTS

Type	HE	Smoke	Chemical
82mm	1/2	2	6
4.2 or 120mm	1	2	6

On-map artillery does not incur the initial cost of 5 asset points. Instead, 82mm mortars cost 3 points.

### 6. VICTORY

In most cases the results are fairly clear-cut. One side will achieve its objective, and the other side will not. However, in a few combinations of missions it is possible for both sides to achieve their objectives. In this case the player who left the highest proportion of his asset points unspent is the winner.

### CAMPAIGN RULES

After you have had some experience in designing individual scenarios, you may want to try your hand at an entire war campaign. To do so, you will need rules to adjudicate what happens between battles. For the purposes of the campaign rules that follow, rules that cover the course of an individual battle are considered to be *tactical rules*; maps on which an individual battle is fought are considered to be *tactical maps*; rules that cover events between battles are considered to be *strategic rules*; and combined maps that consist of all tactical maps and their relationships to one another are considered to be *campaign maps* (sometimes called *strategic maps*).

**The Campaign Map:** To begin a campaign, you must first generate a campaign map.

The campaign map is a strategic-level representation of the location of various battlefields in relation to one another. Each box on the campaign map represents one battlefield—one tactical map. Each tactical map box indicates which maps are used to create the battlefield and how they are oriented to one another, just as the map section of each scenario in the *Scenarios Book* does. It is suggested that one player be the defender of his home country and the other player be the attacker.

**Strategic Turns:** The lines between the boxes on the strategic map indicate which battlefields can be reached from which. Each battlefield is considered to be one strategic turn away from the other battlefields it connects with. A strategic turn is eight hours long; one day on the strategic map consists of one morning turn, one afternoon turn, and one night turn.

**Strategic Movement:** Mechanized forces (forces with no infantry to move on foot) move a maximum distance of three boxes on the strategic map every strategic turn. Infantry forces on foot march one box per strategic turn, but they can never march two strategic turns in a row.

Each strategic turn can therefore be divided into three phases: (1.) first mechanized movement phase, (2.) second mechanized movement phase, and (3.) infantry movement and third mechanized movement phase. (Each strategic turn is equivalent to 60 tactical turns, making each phase equivalent to 20 tactical turns; therefore, phase one represents tactical turns 1-20, phase two represents tactical turns 21-40, and phase three represents tactical turns 41-60.)

Units cannot exit a box that contains enemy forces during strategic movement. (They can exit such boxes during a tactical battle if they break through the opposing forces.)

**Tactical Battles:** At the end of each phase of movement, once all moves have been made for that phase, combat occurs in boxes that contain opposing forces. The force that has had the most recent arrivals to the box is considered the attacker; the other force is the defender. (If both sides have had equally recent arrivals, roll a die to determine who is the attacker.)

The tactical map for that box is set up, and forces are deployed. The attacker has the initiative, and the defender sets up first.

Combat continues until either one side's forces leave the board or 20 tactical turns have passed. At the end of 20 turns, another phase of strategic movement is conducted, possibly bringing reinforcements onto the board.

**Strategic Air Movement:** Helicopters can fly a maximum of six boxes per strategic turn to conduct a mission and another six boxes to return to a base. Helicopters can fly a maximum of 12 boxes to transfer from base to base.

**Air Routes:** Some boxes on the campaign map are not connected by ground routes but are connected by air routes. Air routes are indicated by a dotted line. Air travel distance can be calculated using both ground routes and air routes.

### Tactical Victory

The side that wins control of a box on the strategic map gains back half its destroyed troop counters and may attempt to repair all its vehicles that received damaged results in that battle. For each damaged component (e.g., radio, engine, etc.), roll a die. On a roll of 1-2 the component is fixed; on a roll of 3-6 there are not enough spare parts to fix the component. Repaired vehicles are returned, repaired, to the box in which they were damaged at the end of the next strategic turn.

The other side involved in the battle gains back one-fourth of its destroyed troop counters. It does not gain back any of its damaged vehicles.

### Building Forces

At the beginning of the campaign, each player gets a number of points to spend equivalent to 50 points times the number of boxes on the entire campaign map. With these points, the player can purchase forces as per the design-your-own-scenarios rules. See page 15 of the *Rules Book* for unit costs.

**Air Bases:** Each air base costs 25 points plus 20 points for each helicopter.

**Deployment:** Each player can deploy the forces he purchases in any box or boxes behind his country's border on the campaign map.

### NEW UNITS

As the war wears on, it becomes more and more difficult to replace men and equipment.

**Deployment:** Each player can deploy the forces he purchases in any box or boxes behind his country's border on the campaign map.

### New Units

At the beginning of each morning campaign turn, each player gains 5 percent of his original build points to spend on new forces. Units that have been destroyed may be purchased again at double the normal costs. Totally new types of units cost triple the normal costs.

New units that are purchased in this way begin the campaign turn in any box controlled by the player.

# COMBAT AND MAP TABLES

## MODIFIERS TO SPOTTING

Condition	Modifier
Novice	-1
Experienced	0
Veteran	+1
Elite	+2
Spotting a Vehicle	+1
Spotting From a Vehicle	-1

Note: The above modifiers are to the number needed to roll. Thus, an Elite troop trying to spot a enemy unit 4 hexes away would need to roll a 4 or less (2+2).

## ATTACK MODIFIERS

Condition	Modifier
Novice	-1
Trained	0
Veteran	+1
Elite	+2
Firing into rubble	-1
Firing into woods	-1
Firing into town	-1

## VEHICLE COMBAT RESULTS TABLE (VCRT)

Die	1:3	1:2	2:3	1:1	3:2	2:1	3:1	4:1	5:1
1	MIN	MIN	MAJ	MAJ	MAJ	MAJ	X	X	X
2	NE	MIN	MIN	MIN	MAJ	MAJ	MAJ	X	X
3	NE	NE	MIN	MIN	MIN	MAJ	MAJ	MAJ	X
4	NE	NE	NE	MIN	MIN	MIN	MAJ	MAJ	MAJ
5	NE	NE	NE	NE	MIN	MIN	MIN	MAJ	MAJ
6	NE	NE	NE	NE	NE	MIN	MIN	MIN	MAJ

An NE result means that the shot was reflected or absorbed by the armor—there is no further result. On a MIN result, roll a die on the defending vehicle's minor damage table (keeping in mind whether the shot was against the body or turret) and implement the results there. On a MAJ result, consult the vehicle's major damage table (either for the body or turret) and implement that result. An X result destroys the vehicle entirely. (See Escaping From Destroyed Vehicles.)

Any result other than NE against a Tread or Wheel means that the vehicle is immobilized for the remainder of the game.

## SPOTTING

Range (in hexes)	1	2	3	4
Roll*	A	4	3	2









A: Automatic spot.

\*: Roll this number or less on one die to spot.

## MORALE POINT LOSSES

Unit Type	Morale Points
Leader	3
One Infantryman	1
Soft Vehicle	4
Armored Vehicle	6

## TERRAIN EFFECTS CHART

Terrain Type	Movement Costs	Combat Effects	Line-of-Fire Effects
 Clear	1 MP	No effect	No effect
 Woods	2 MP	-1 to number needed to hit	Blocks LOF through hex
 Town	2 MP	-1 to number needed to hit	Blocks LOF through hex
 Rubble	2 MP	-1 to number needed to hit unit in rubble	
 Building	1 MP to enter	-1 to number needed to hit +1 when firing from building	Blocks LOF through hex
 Road	1 MP	No effect	No effect
 Trail	1 MP	No effect	No effect
 Bridge	1 MP	No effect	No effect
 River	3 MP	Impassable except at bridge or by amphibious vehicle	No effect

## ELEVATION CHART

Color	Level
Green	0
Dark Green	1
Medium Brown	2
Dark Brown	3

A unit is considered to be on the highest terrain in the hex it occupies.

## ANTIARMOR WEAPON RANGE EFFECTS

Range	Distance	Attack
Close	1/2 or less	× 2
Medium	Equal or less	× 1
Long	Twice or less	× 1/2
Extreme	Four times or less	× 1/4

Note: Round all fractions up when calculating distance and attack strengths.

## ABBREVIATIONS

MF—Movement Factor  
FAV—Fast Attack Vehicle  
MBT—Main Battle Tank  
APC—Armored Personnel Carrier



# LAST 1 BATTLE™

Copyright © 1989 GDW, CC-0551/M1

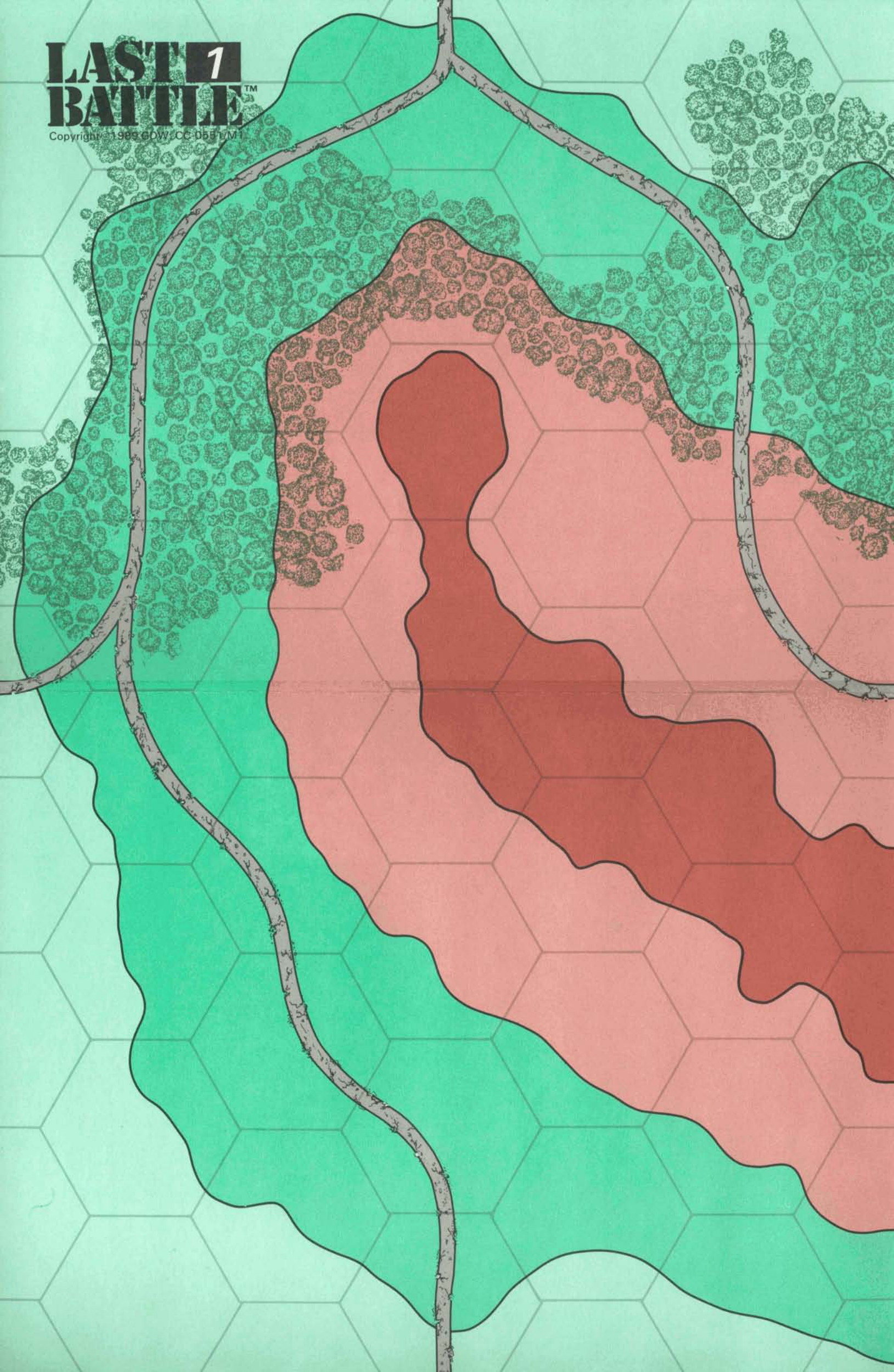

# LAST 2 BATTLE™

Copyright © 1989 GDW, Inc. 0581/M2

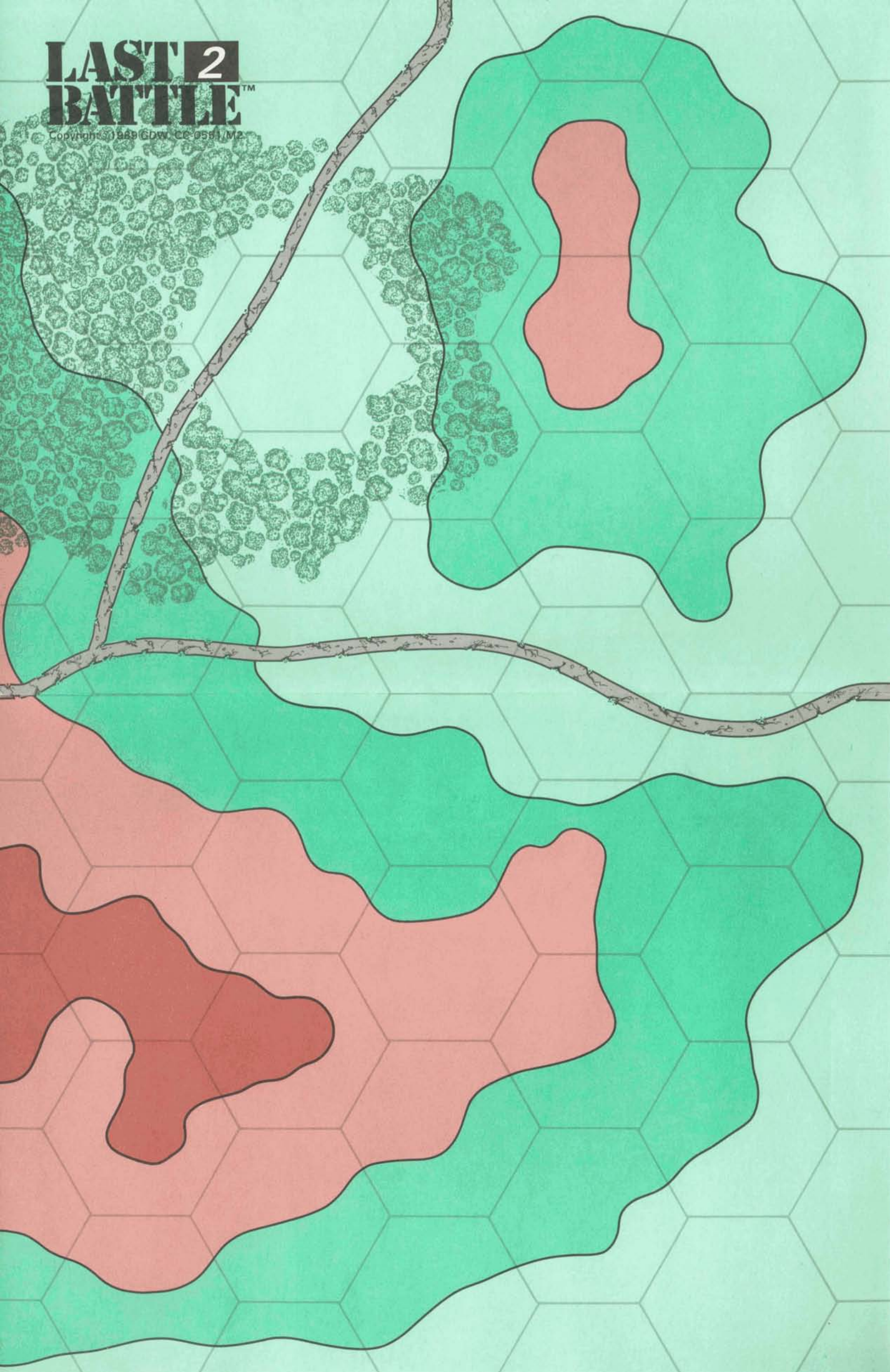

# LAST 3 BATTLE™

Copyright © 1989 GDW. CC-0551/M8

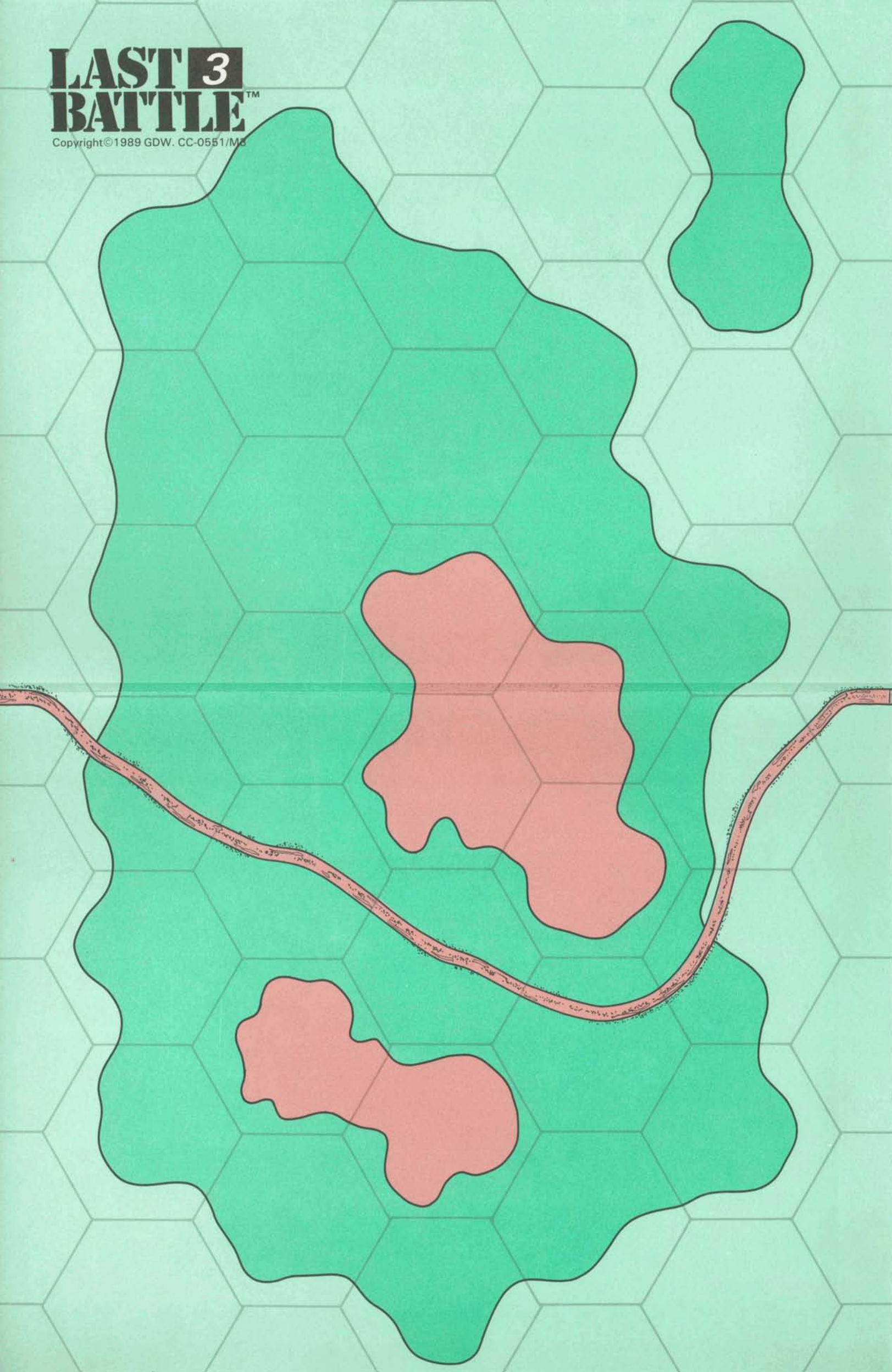

# LAST 4 BATTLE™

Copyright © 1989 GDW. CC-0551/M4

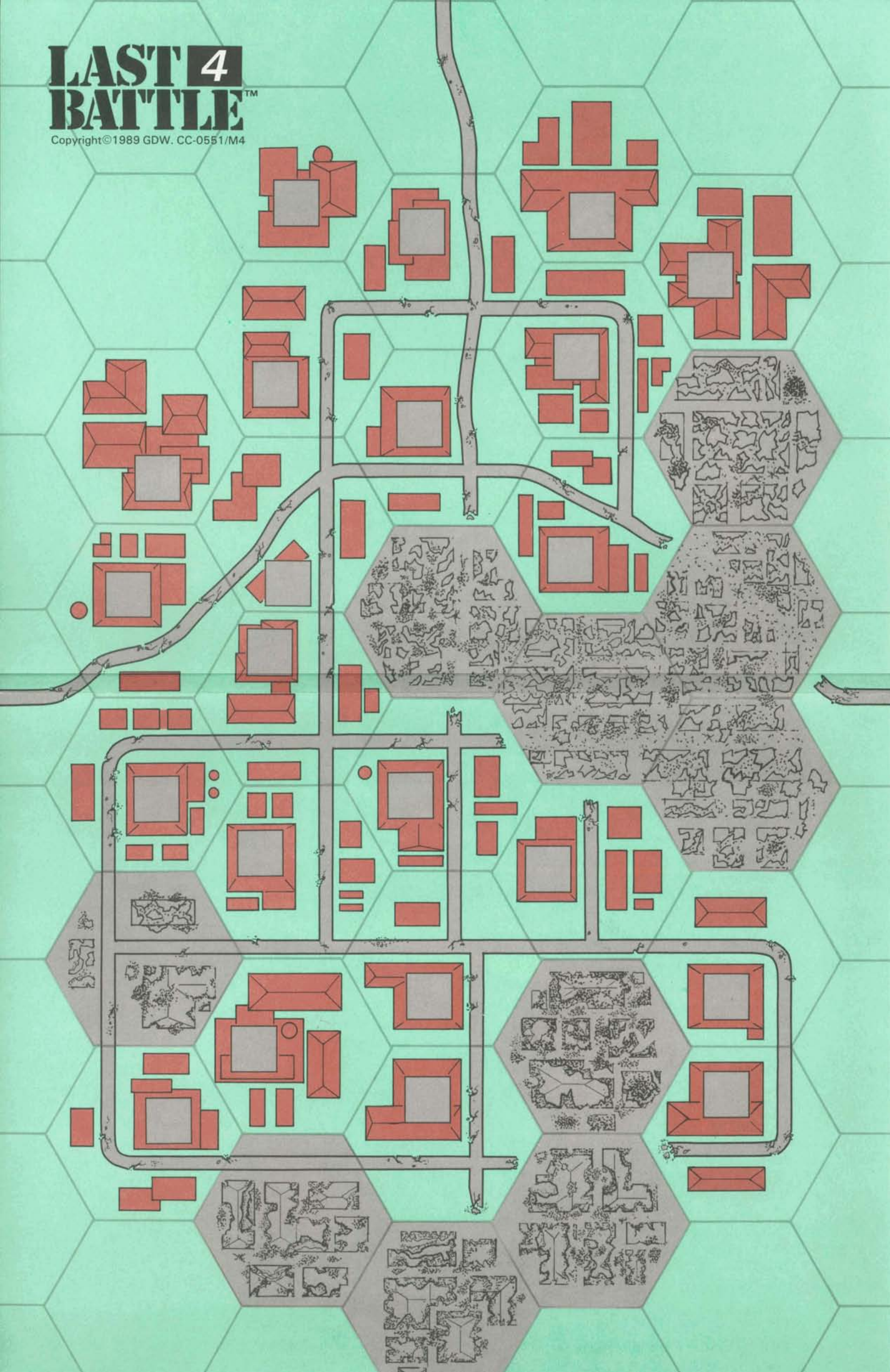

# LAST 5 BATTLE™

Copyright © 1989 GDW. CC-0551/M5

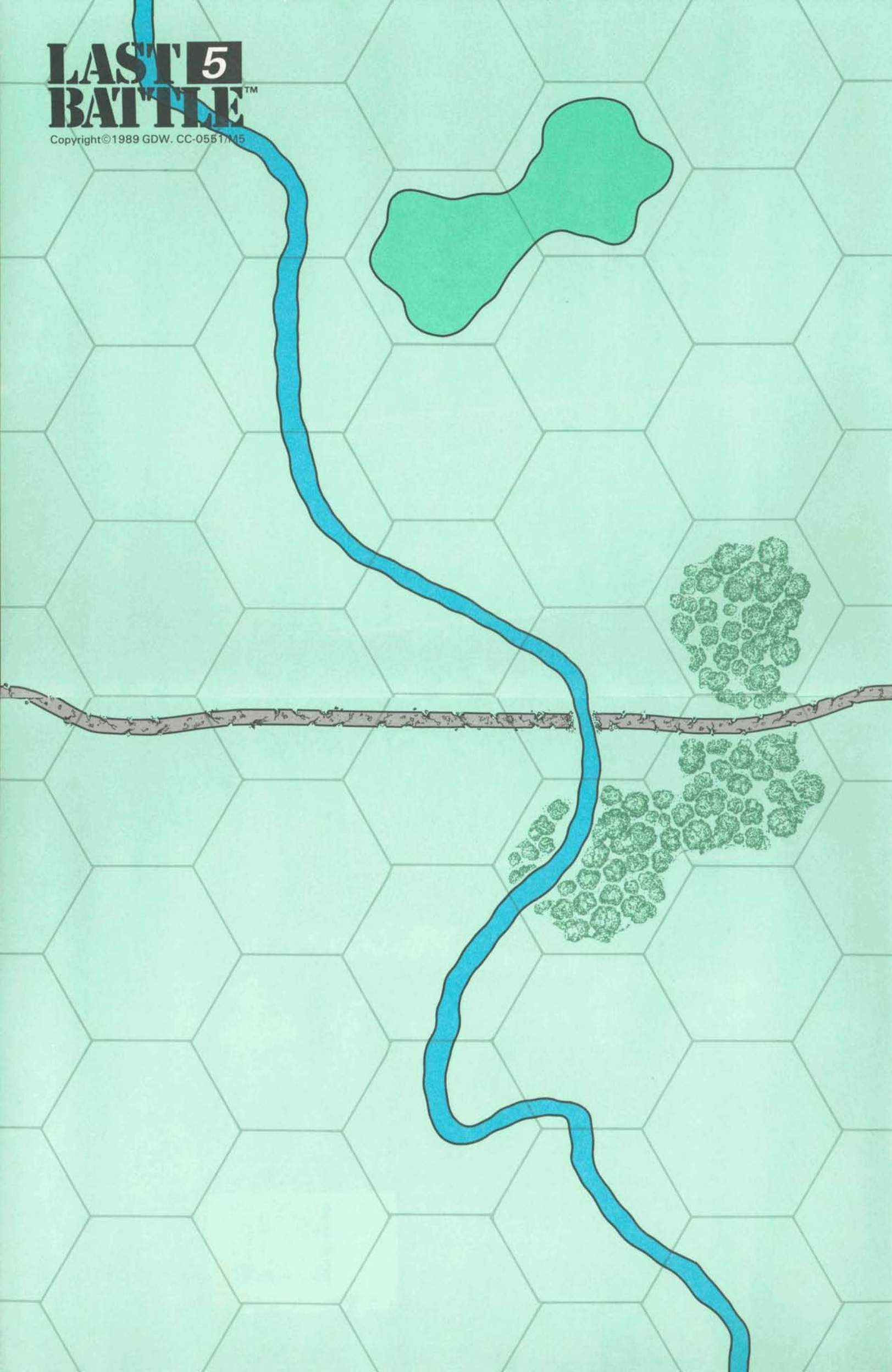

# LAST 6 BATTLE™

Copyright © 1989 GDW. CC-0551/M6

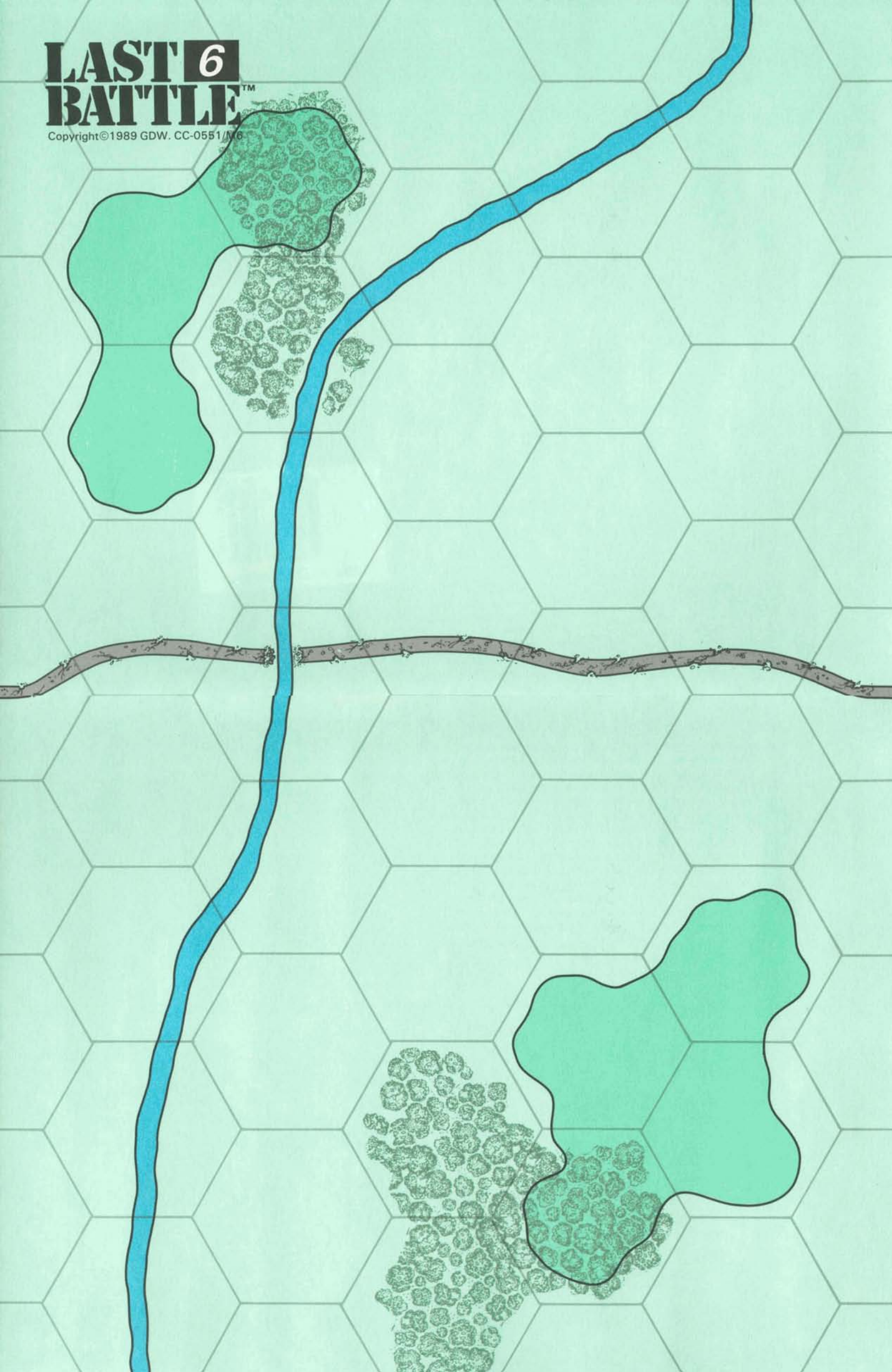

# Generic

APC

ID#: \_\_\_\_\_  
Crew: \_\_\_\_\_  
Troops: \_\_\_\_\_  
Movement: \_\_\_\_\_  
RF: \_\_\_\_\_  
Troop  
Quality: \_\_\_\_\_

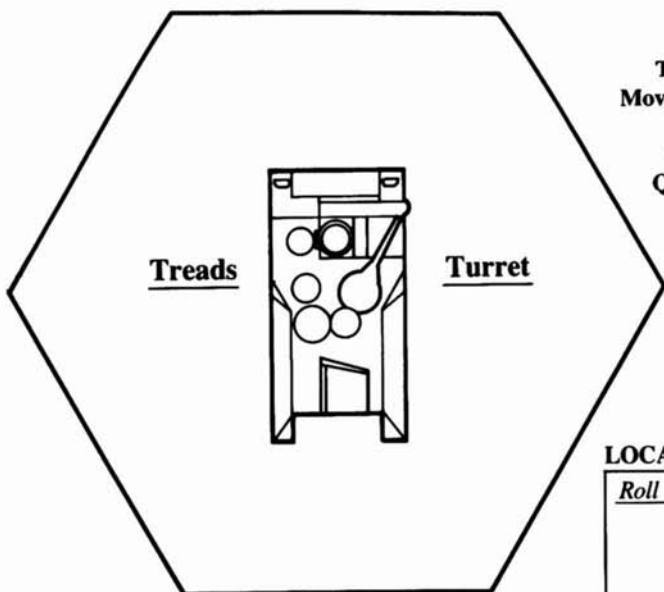
## LOCATION CHART

<i>Roll</i>	<i>Hit</i>

## ARMAMENT CHART

<i>Weapon</i>	<i>Antivehicle</i>	<i>Antipersonnel</i>

Functional

Functional

Functional

### TURRET Minor

<i>Roll</i>	<i>Hit</i>

### BODY Minor

<i>Roll</i>	<i>Hit</i>

### Major

<i>Roll</i>	<i>Hit</i>

### Major

<i>Roll</i>	<i>Hit</i>

Notes:

NATO

# Leopard II

MBT

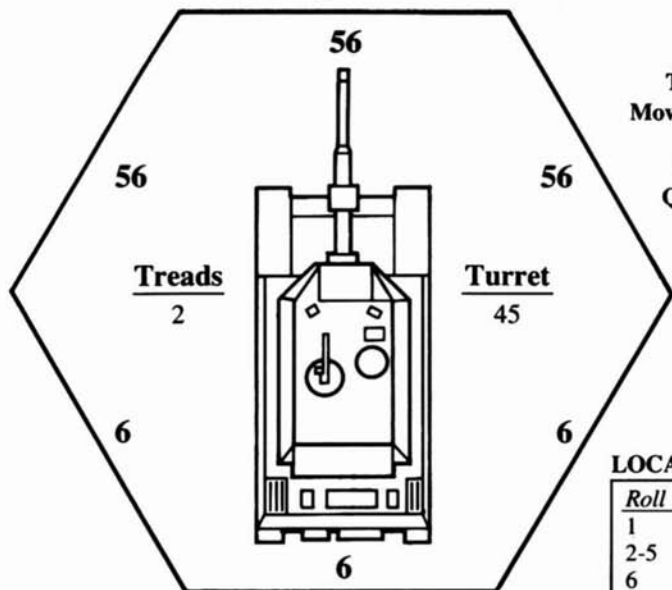

**ID#:** \_\_\_\_\_  
**Crew:** 4  
**Troops:** 0  
**Movement:** 5/4  
**RF:** \_\_\_\_\_  
**Troop Quality:** \_\_\_\_\_

Comnder

Driver

Gunner

Loader

Functional

Functional

Functional

## LOCATION CHART

Roll	Hit
1	Treads
2-5	Body
6	Turret

## ARMAMENT CHART

Weapon	Antivehicle	Antipersonnel
120mm	70, 20	3, 16
MAG MG	—	2, 5
M2HB	3, 6	2, 6

### TURRET Minor

Roll	Hit
1-2	RF
3-4	Loader
5	Gunner
6	Major Turret

### BODY Minor

Roll	Hit
1	Commander
2	Gunner
3	MAG MG
4	Radio
5	Driver
6	Major Body

### Major

Roll	Hit
1-3	120mm
4-5	Ammo
6	Minor Body

### Major

Roll	Hit
1-3	Engine
4	Ammo
5-6	Fuel

Notes:



# Generic

**MBT**

ID#: \_\_\_\_\_  
Crew: \_\_\_\_\_  
Troops: \_\_\_\_\_  
Movement: \_\_\_\_\_  
RF: \_\_\_\_\_  
Troop  
Quality: \_\_\_\_\_

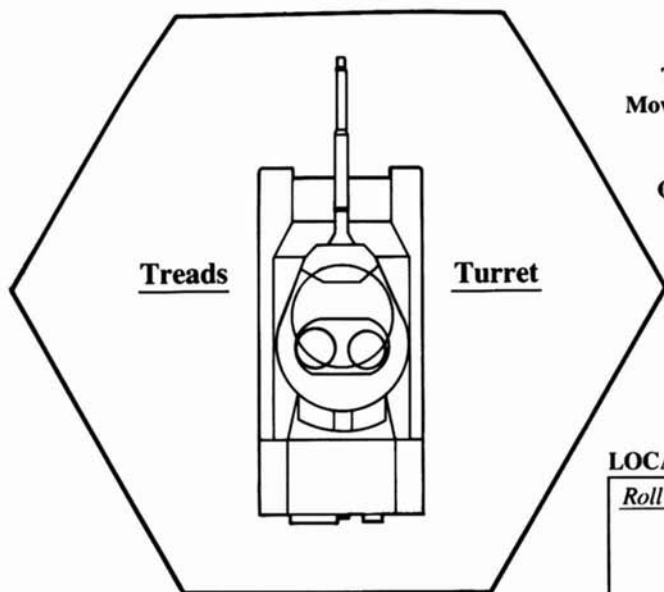
## LOCATION CHART

<i>Roll</i>	<i>Hit</i>

## ARMAMENT CHART

Functional
Functional
Functional

<i>Weapon</i>	<i>Antivehicle</i>	<i>Antipersonnel</i>

### TURRET Minor

<i>Roll</i>	<i>Hit</i>

### BODY Minor

<i>Roll</i>	<i>Hit</i>

### Major

<i>Roll</i>	<i>Hit</i>

### Major

<i>Roll</i>	<i>Hit</i>

**Notes:**

## NATO

## FAV

Comnder/  
Gunner

Driver

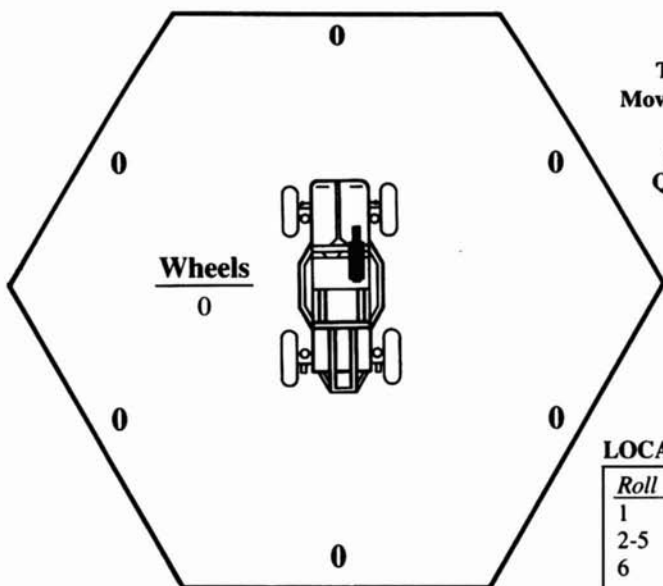

ID#: \_\_\_\_\_  
Crew: 2  
Troops: 0  
Movement: 8/3  
RF: None  
Troop Quality: \_\_\_\_\_

### LOCATION CHART

Roll	Hit
1	Wheels
2-5	Body
6	Miss

One of the following weapons may be mounted on the FAV\*:

Weapon Mounted

GPMG  
HMG  
AGL  
ATGM

### BODY Minor

Roll	Hit
1	Driver
2	Comnder/Gunner
3-4	Weapon
5	Radio
6	Major Body

### Major

Roll	Hit
1-4	Engine
5-6	Fuel

**Notes:** Unless otherwise noted in the scenario, an FAV will mount a GPMG.

**NATO****HMMWV****Fire Support Vehicle**Comnder/  
Gunner

Driver

Troops

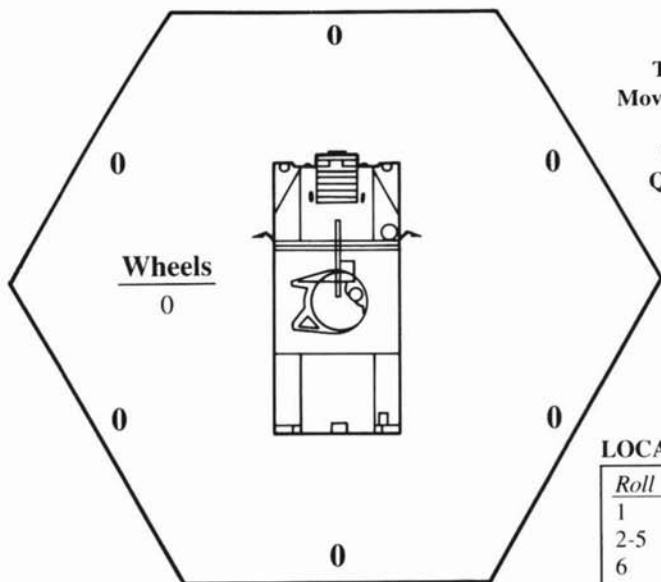
 ID#: \_\_\_\_\_  
 Crew: 2  
 Troops: 4  
 Movement: 7/4  
 RF: \_\_\_\_\_  
 Troop  
 Quality: \_\_\_\_\_
**ARMAMENT CHART****LOCATION CHART**

<i>Roll</i>	<i>Hit</i>
1	Wheels
2-5	Body
6	Miss

Functional

<i>Weapon</i>	<i>Antivehicle</i>	<i>Antipersonnel</i>
25mm Autocannon	10, 10	2, 10

**BODY**  
**Minor**

<i>Roll</i>	<i>Hit</i>
1	Driver
2	Commander/ Gunner
3	Radio
4-5	Troops
6	Major Body

**Major**

<i>Roll</i>	<i>Hit</i>
1-2	Engine
3-4	Fuel
5-6	25mm Autocannon

**Notes:**

# NATO

# HMMWV

Comnder/  
Gunner

Driver

Troops

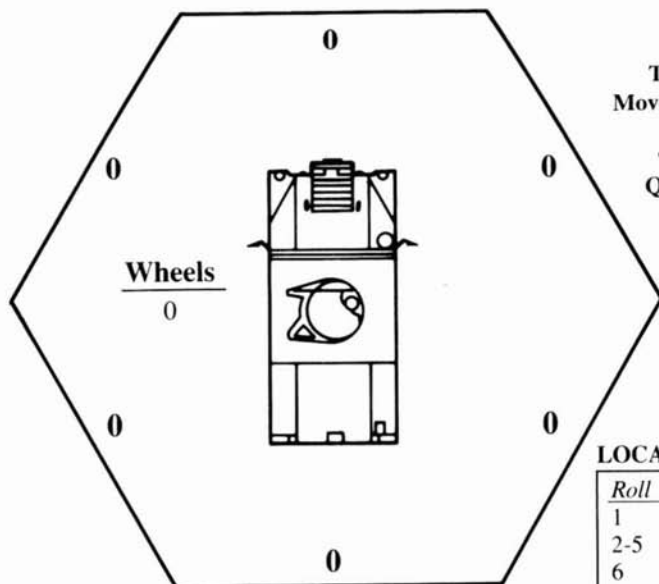

ID#: \_\_\_\_\_  
 Crew: 2  
 Troops: 4  
 Movement: 7/4  
 RF: \_\_\_\_\_  
 Troop Quality: \_\_\_\_\_

## LOCATION CHART

Roll	Hit
1	Wheels
2-5	Body
6	Miss

One of the following weapons may be mounted on a HMMWV\*:

Weapon Mounted

GPMG  
 HMG  
 AGL  
 ATGM

## BODY Minor

Roll	Hit
1	Driver
2	Comnder/Gunner
3	Radio
4-5	Troops
6	Major Body

## Major

Roll	Hit
1-2	Engine
3-4	Fuel
5-6	Weapon

**Notes:** \*Unless otherwise stated in the scenario, the HMMWV will have a HMG mounted.

**NATO****LAV-25****LCV**

Comnder

Driver

Gunner

Troops

Functional

Functional

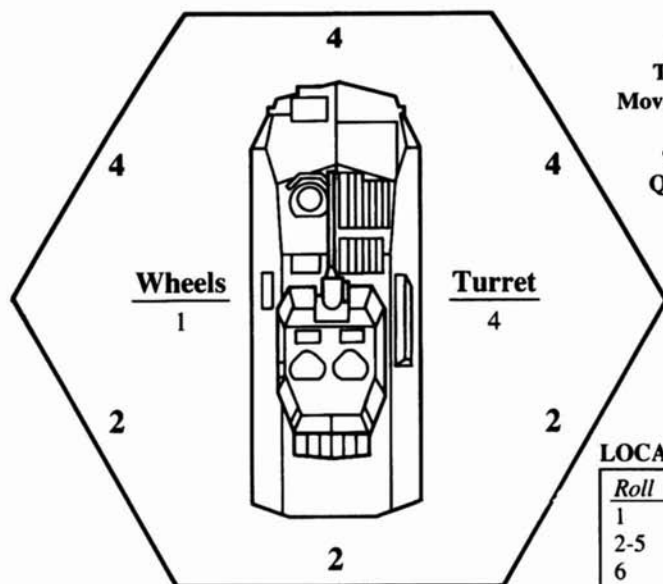

ID#: \_\_\_\_\_  
 Crew: 3  
 Troops: 6  
 Movement: 6/4A  
 RF: \_\_\_\_\_  
 Troop Quality: \_\_\_\_\_

**ARMAMENT CHART**

<i>Weapon</i>	<i>Antivehicle</i>	<i>Antipersonnel</i>
25mm Autocannon	10, 10	2, 10
MAG MG	—	2, 5

**LOCATION CHART**

<i>Roll</i>	<i>Hit</i>
1	Wheels
2-5	Body
6	Turret

**TURRET**  
Minor

<i>Roll</i>	<i>Hit</i>
1-2	MAG MG
3	Gunner
4	Commander
5	RF
6	Major Turret

**Major**

<i>Roll</i>	<i>Hit</i>
1-3	25mm Autocannon
4	Ammo
5	Commander & Gunner
6	Minor Body

**BODY**  
Minor

<i>Roll</i>	<i>Hit</i>
1-2	Radio
3-4	Troops
5	Driver
6	Major Body

**Major**

<i>Roll</i>	<i>Hit</i>
1-2	Engine
3-4	Fuel
5-6	Ammo

**Notes:**

**NATO**

# LAV-75

**LCV**

Comnder

Driver

Gunner

ID#: \_\_\_\_\_  
 Crew: 3  
 Troops: 0  
 Movement: 6/4  
 RF: \_\_\_\_\_  
 Troop Quality: \_\_\_\_\_

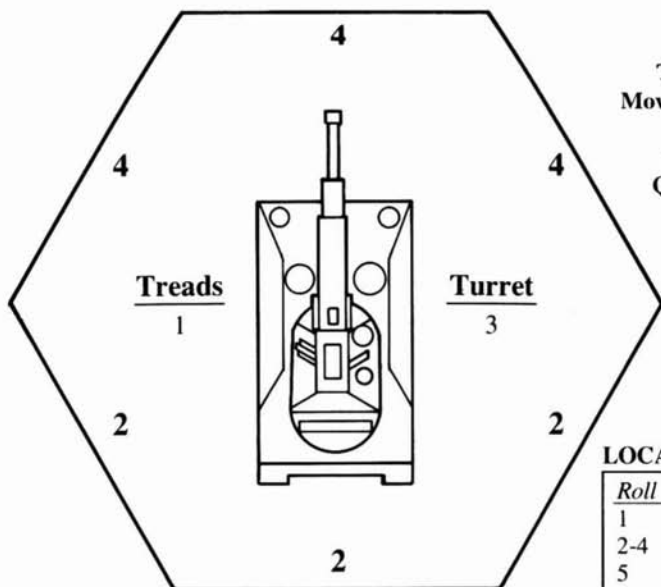

**LOCATION CHART**

Roll	Hit
1	Treads
2-4	Body
5	Turret
6	Miss

**ARMAMENT CHART**

Functional

Functional

Weapon	Antivehicle	Antipersonnel
75mm Autocannon	30, 16	8, 12
MAG MG	—	2, 5

**TURRET**  
Minor

Roll	Hit
1-2	MAG MG
3-4	Commander
5	RF
6	Major Turret

**BODY**  
Minor

Roll	Hit
1-2	Driver
3-4	Gunner
5	Radio
6	Major Body

**Major**

Roll	Hit
1-3	75mm Autocannon
4-5	Commander & MAG MG
6	Minor Body

**Major**

Roll	Hit
1-3	Engine
4	Ammo
5-6	Fuel

**Notes:**

# NATO

# M1 Abrams

# MBT

Comnder

Driver

Gunner

Loader

Functional

Functional

Functional

ID#: \_\_\_\_\_  
 Crew: 4  
 Troops: 0  
 Movement: 5/4  
 RF: \_\_\_\_\_  
 Troop Quality: \_\_\_\_\_

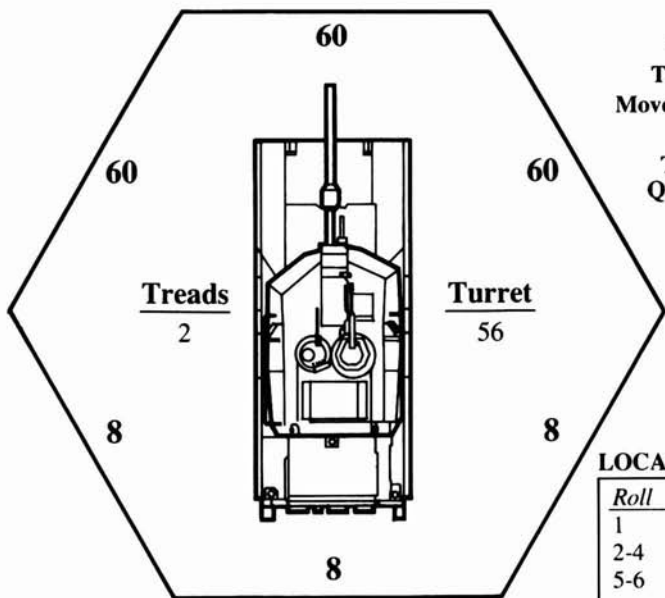

### LOCATION CHART

Roll	Hit
1	Treads
2-4	Body
5-6	Turret

### ARMAMENT CHART

Weapon	Antivehicle	Antipersonnel
105mm	60, 20	3, 16
MAG MG	—	2, 5
M2HB	3, 6	2, 6

### TURRET Minor

Roll	Hit
1	Commander
2	RF
3	Gunner
4	MAG MG
5	M2HB
6	Major Turret

### BODY Minor

Roll	Hit
1	Driver
2-3	Radio
4	Commander
5	Loader
6	Major Body

### Major

Roll	Hit
1	Commander & Gunner
2	Gunner & Loader
3-4	105mm
5	Ammo*
6	Minor Body

### Major

Roll	Hit
1-2	Engine
3-4	Fuel
5-6	Ammo*

**Notes:** \*The M1 has blow-out ports in case the 105mm ammunition detonates inside the vehicle. Roll a die: 1-4, no ammo for the 105mm; 5-6, vehicle destroyed.

**NATO****M113 ACCV A3****APC**Comnder/  
Gunner

Driver

Troops

Troops

Functional

Functional

Functional

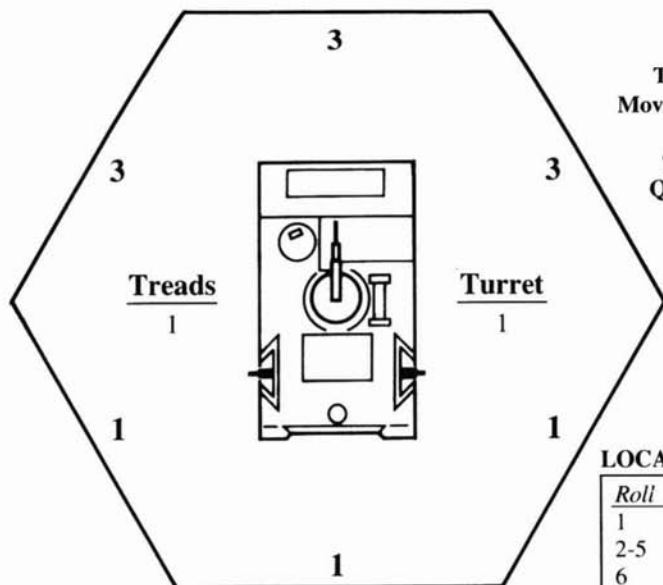
**ID#:** \_\_\_\_\_  
**Crew:** 2  
**Troops:** 11  
**Movement:** 4/3A  
**RF:** \_\_\_\_\_  
**Troop Quality:** \_\_\_\_\_
**LOCATION CHART**

Roll	Hit
1	Treads
2-5	Body
6	Turret

**ARMAMENT CHART**

Weapon	Antivehicle	Antipersonnel
M2HB	3, 6	2, 6
M60	—	2, 5
M60	—	2, 5

**TURRET  
Minor**

Roll	Hit
1-2	Commander/ Gunner
3-5	M60
6	Major Turret

**Major**

Roll	Hit
1-3	Comnder/Gunner & M2HB
4-5	M2HB
6	Minor Body

**BODY  
Minor**

Roll	Hit
1	Radio
2	Driver
3	Commander/ Gunner
4-5	Troops
6	Major Body

**Major**

Roll	Hit
1-4	Engine
5-6	Fuel

**Notes:** Two troops may fire the M60s.



**NATO****M113****APC**Comnder/  
Gunner

Driver

Troops

Troops

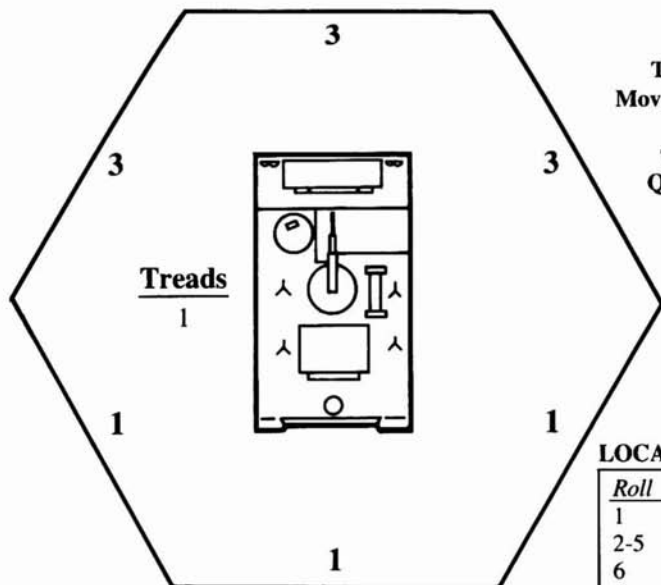

ID#: \_\_\_\_\_  
 Crew: 2  
 Troops: 11  
 Movement: 4/3A  
 RF: \_\_\_\_\_  
 Troop Quality: \_\_\_\_\_

**LOCATION CHART**

<i>Roll</i>	<i>Hit</i>
1	Treads
2-5	Body
6	Miss

One of the following weapons may be mounted on a M113:

Weapon  
Mounted

GPMG  
HMG  
AGL  
ATGM

**BODY**  
Minor

<i>Roll</i>	<i>Hit</i>
1	Radio
2	Driver
3	Comnder/Gunner
4-5	Troops
6	Major Body

**Major**

<i>Roll</i>	<i>Hit</i>
1-2	Weapon
3-4	Engine
5-6	Fuel

**Notes:**

**NATO**

**M1A1**

**MBT**

Comnder

Driver

Gunner

Loader

Functional

Functional

Functional

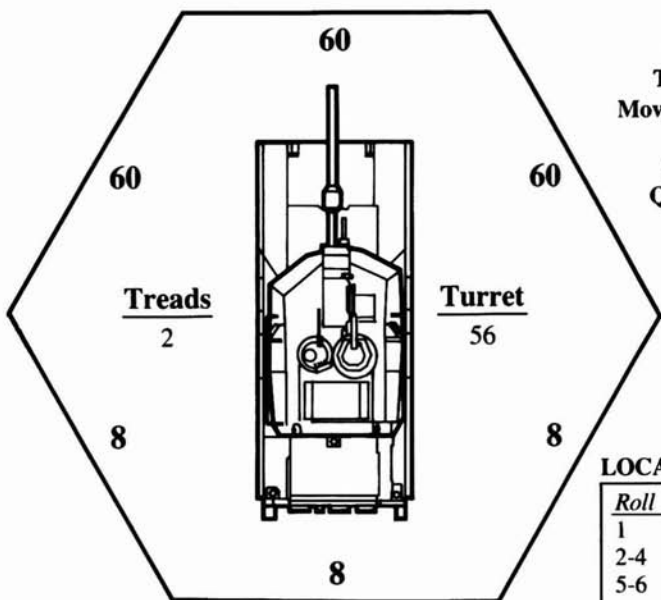

ID#: \_\_\_\_\_  
 Crew: 4  
 Troops: 0  
 Movement: 5/4  
 RF: \_\_\_\_\_  
 Troop Quality: \_\_\_\_\_

**LOCATION CHART**

Roll	Hit
1	Treads
2-4	Body
5-6	Turret

**ARMAMENT CHART**

Weapon	Antivehicle	Antipersonnel
120mm	70, 20	3, 16
MAG MG	—	2, 5
M2HB	3, 6	2, 6

**TURRET  
Minor**

Roll	Hit
1-2	Commander
3	RF
4	Gunner
5	MAG MG
6	Major Turret

**BODY  
Minor**

Roll	Hit
1	Driver
2-3	Radio
4	Commander
5	Loader
6	Major Body

**Major**

Roll	Hit
1	Commander & Gunner
2	Gunner & Loader
3-4	120mm
5	Ammo*
6	Minor Body

**Major**

Roll	Hit
1-2	Engine
3-4	Fuel
5-6	Ammo*

**Notes:** \*The M1A1 has blow-out ports in case the 120mm ammunition detonates inside the vehicle. Roll a die: 1-4, no ammo for 120mm; 5-6, vehicle destroyed.

NATO

M1A2

MBT

Comnder
Driver
Gunner

ID#: \_\_\_\_\_  
 Crew: 3  
 Troops: 0  
 Movement: 5/4  
 RF: \_\_\_\_\_  
 Troop Quality: \_\_\_\_\_

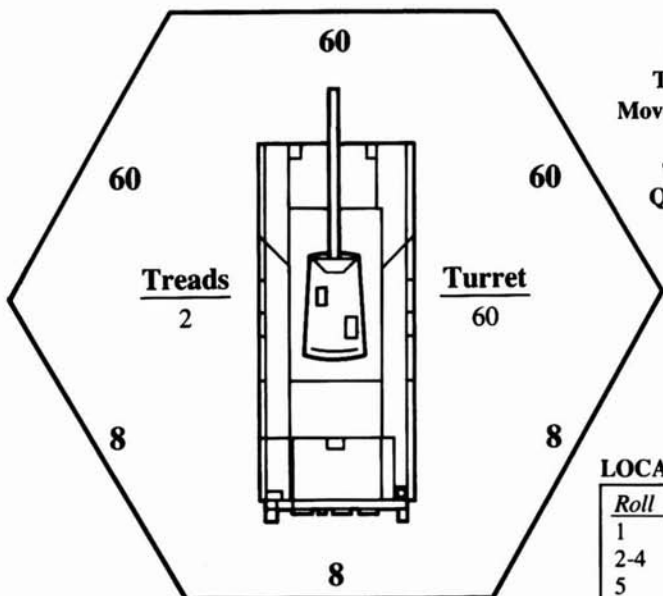

## LOCATION CHART

Roll	Hit
1	Treads
2-4	Body
5	Turret
6	Miss

## ARMAMENT CHART

Weapon	Antivehicle	Antipersonnel
120mm	70, 20	3, 16
MAG MG	—	2, 5
M2HB	3, 6	2, 6

Functional
Functional
Functional

**TURRET**  
 Minor

Roll	Hit
1	RF
2-3	Autoloader*
4	MAG MG
5-6	Major Turret

## Major

Roll	Hit
1-4	120mm
5-6	Minor Body

**BODY**  
 Minor

Roll	Hit
1	Driver
2	Commander
3	Gunner
4-5	M2HB
6	Major Body

## Major

Roll	Hit
1-2	Engine
3-4	Fuel
5-6	Ammo**

**Notes:** \*The autoloader has been hit. Each attack phase roll a die: 1-2, the 120mm may fire normally; 3-6, it is jammed. \*\*The M1A2 has blow-out ports in case the 120mm ammunition detonates inside the vehicle. Roll a die: 1-4, no ammo left for 120mm; 5-6, vehicle destroyed.

**NATO****M2 Bradley****APC**

Comnder

Driver

Gunner

Troops

Functional

Functional

Functional

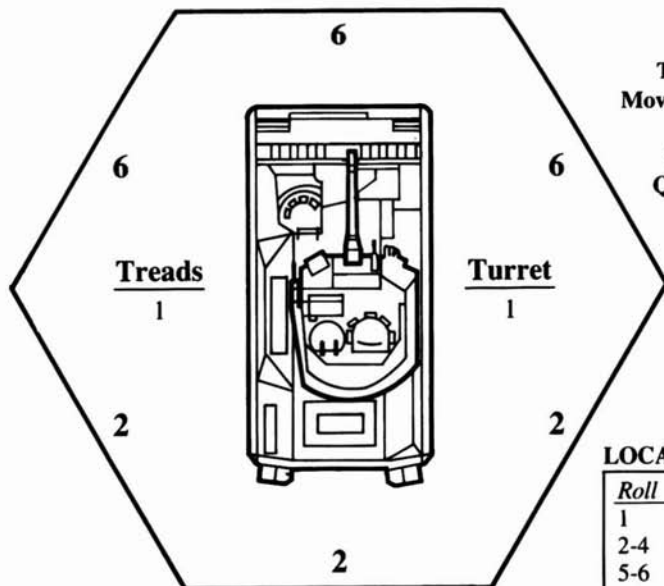

ID#: \_\_\_\_\_  
 Crew: 3  
 Troops: 7  
 Movement: 5/4A  
 RF: \_\_\_\_\_  
 Troop Quality: \_\_\_\_\_

**Treads**

1

**Turret**

1

2

2

2

**LOCATION CHART**

Roll	Hit
1	Treads
2-4	Body
5-6	Turret

**ARMAMENT CHART**

Weapon	Antivehicle	Antipersonnel
25mm Autocannon	10, 10	2, 10
Twin TOW	30, 60	3, 60
MAG MG	—	2, 5

**TURRET  
Minor**

Roll	Hit
1	RF
2	Twin TOW
3	MAG MG
4	Gunner
5	Commander
6	Major Turret

**Major**

Roll	Hit
1-2	25mm Autocannon
3-4	Ammo
5	Commander & MAG MG
6	Minor Body

**BODY  
Minor**

Roll	Hit
1	Radio
2-3	Driver
4-5	Troops
6	Major Body

**Major**

Roll	Hit
1-2	Ammo
3-4	Engine
5-6	Fuel

**Notes:**

NATO

M60A4

MBT

Comnder

Driver

Gunner

Loader

Functional

Functional

Functional

ID#: \_\_\_\_\_  
 Crew: 4  
 Troops: 0  
 Movement: 5/3  
 RF: \_\_\_\_\_  
 Troop Quality: \_\_\_\_\_

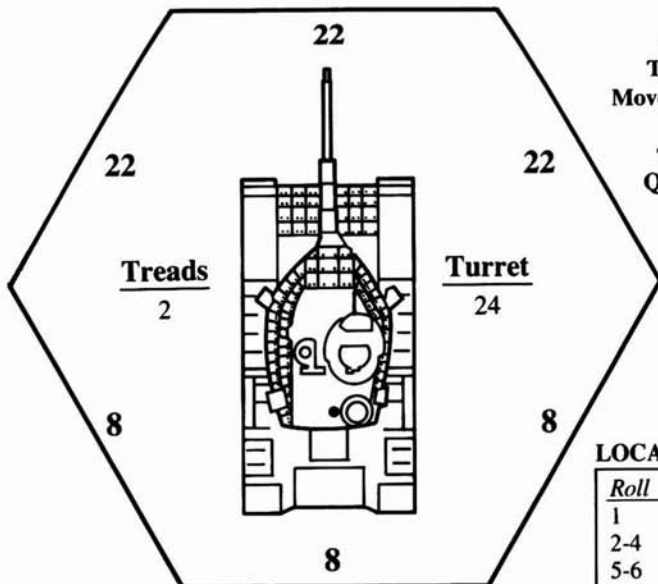

LOCATION CHART

Roll	Hit
1	Treads
2-4	Body
5-6	Turret

ARMAMENT CHART

Weapon	Antivehicle	Antipersonnel
105mm	60, 20	3, 16
M2HB	3, 6	2, 6
MAG MG	—	2, 5

TURRET  
Minor

Roll	Hit
1	MAG
2	M2HB
3-4	Commander
5	RF
6	Major Turret

BODY  
Minor

Roll	Hit
1	Driver
2	Gunner
3	Loader
4	MAG MG
5	Radio
6	Major Body

Major

Roll	Hit
1-3	105mm
4-5	M2HB & Commander
6	Minor Body

Major

Roll	Hit
1-3	Engine
4-5	Fuel
6	Ammo

Notes:

NATO

# Stingray

MBT

Comnder

Driver

Gunner

Loader

Functional

Functional

Functional

ID#: \_\_\_\_\_  
 Crew: 4  
 Troops: 0  
 Movement: 5/4  
 RF: \_\_\_\_\_  
 Troop Quality: \_\_\_\_\_

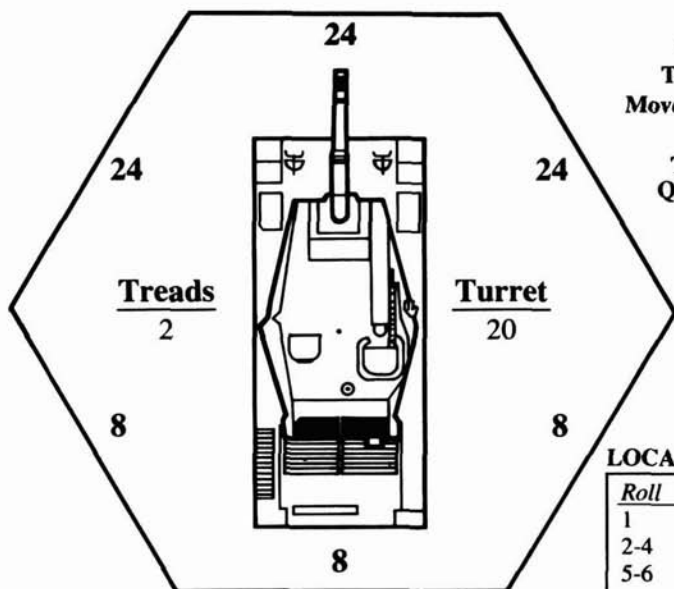

### LOCATION CHART

Roll	Hit
1	Treads
2-4	Body
5-6	Turret

### ARMAMENT CHART

Weapon	Antivehicle	Antipersonnel
105mm	60, 20	3, 16
MAG MG	—	2, 5
M2HB	3, 6	2, 6

### TURRET Minor

Roll	Hit
1	RF
2-3	MAG MG
4	Commander
5	M2HB
6	Major Turret

### BODY Minor

Roll	Hit
1-2	Driver
3	Radio
4	Gunner
5	Commander
6	Major Body

### Major

Roll	Hit
1-3	105mm
4-5	Commander & MAG MG
6	Minor Body

### Major

Roll	Hit
1-3	Engine
4	Fuel
5-6	Ammo

Notes:

# Generic

# Truck

Comnder

Driver

Troops

Troops

Functional

Functional

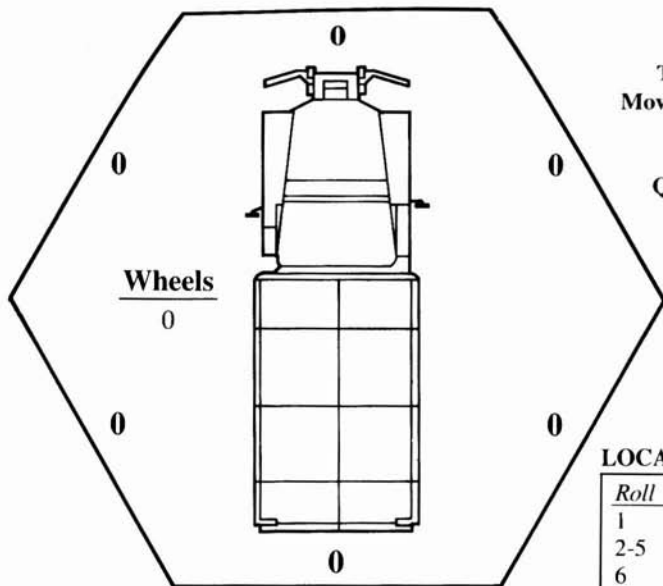

ID#: \_\_\_\_\_  
 Crew: 2  
 Troops: 20  
 Movement: 6/3  
 RF: \_\_\_\_\_  
 Troop Quality: \_\_\_\_\_

## ARMAMENT CHART

<i>Weapon</i>	<i>Antivehicle</i>	<i>Antipersonnel</i>

## LOCATION CHART

<i>Roll</i>	<i>Hit</i>
1	Wheels
2-5	Body
6	Miss

## BODY Minor

<i>Roll</i>	<i>Hit</i>
1	Driver
2	Commander
3	Radio
4-5	Troops
6	Major Body

## Major

<i>Roll</i>	<i>Hit</i>
1-4	Engine
5-6	Fuel

Notes:

**USSR****BMD-B****APC**

Comnder

Driver

Gunner

Troops

Functional

Functional

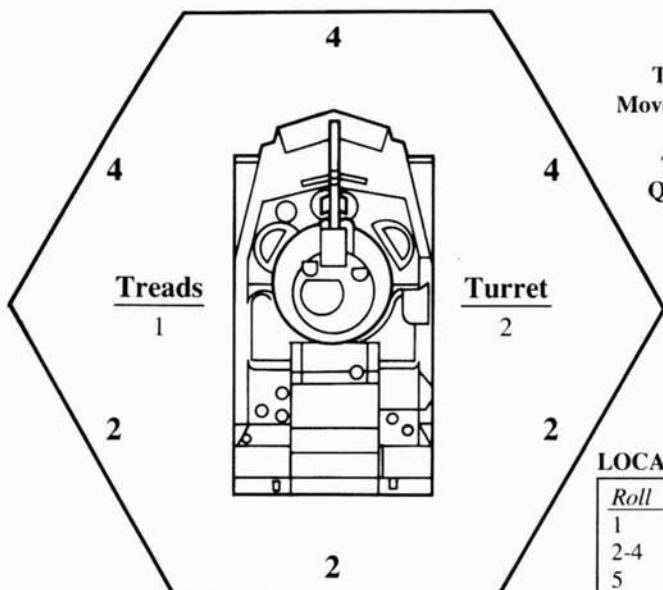
 ID#: \_\_\_\_\_  
 Crew: 3  
 Troops: 6  
 Movement: 6/3A  
 RF: \_\_\_\_\_  
 Troop Quality: \_\_\_\_\_
**LOCATION CHART**

Roll	Hit
1	Treads
2-4	Body
5	Turret
6	Miss

**ARMAMENT CHART**

Weapon	Antivehicle	Antipersonnel
30mm Autocannon	12, 10	3, 10
PK MG	—	2, 5

**TURRET**  
Minor

Roll	Hit
1	Gunner
2	Commander
3-4	PK MG
5	RF
6	Major Turret

**BODY**  
Minor

Roll	Hit
1	Driver
2	Radio
3-5	Troops
6	Major Body

**Major**

Roll	Hit
1-3	30mm Autocannon
4-5	Commander & PK MG
6	Minor Body

**Major**

Roll	Hit
1-4	Engine
5-6	Fuel

**Notes:**



**USSR****BMP-B/C****APC**

Comnder

Driver

Gunner

Troops

Functional

Functional

Functional

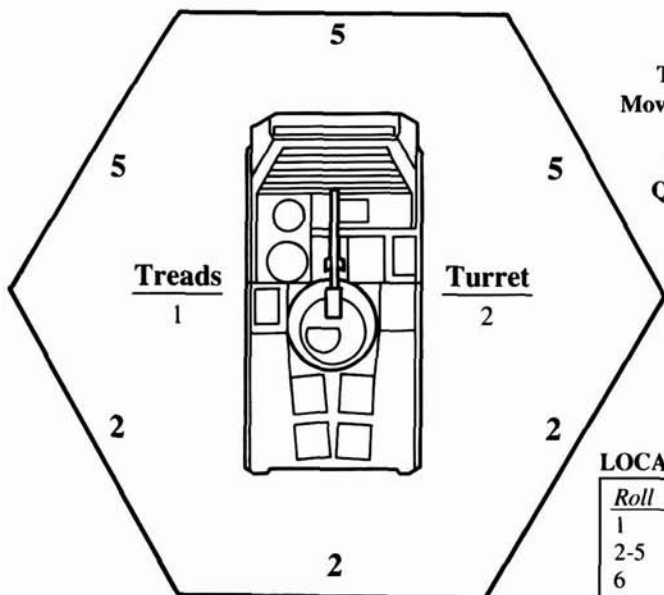

ID#: \_\_\_\_\_  
 Crew: 3  
 Troops: 6  
 Movement: 5/3A  
 RF: \_\_\_\_\_  
 Troop Quality: \_\_\_\_\_

**LOCATION CHART**

Roll	Hit
1	Treads
2-5	Body
6	Turret

**ARMAMENT CHART**

Weapon	Antivehicle	Antipersonnel
30mm Autocannon	12, 10	3, 10
AT-5	35, 60	2, 60
PK MG	—	2, 5

**TURRET  
Minor**

Roll	Hit
1	Gunner
2	Commander
3	AT-5
4	PK MG
5	RF
6	Major Turret

**Major**

Roll	Hit
1	Gunner & Commander
2-4	30mm Autocannon
5	Ammo
6	Minor Body

**BODY  
Minor**

Roll	Hit
1	Driver
2	Commander
3	Radio
4-5	Troops
6	Major Body

**Major**

Roll	Hit
1-2	Engine
3-4	Ammo
5-6	Fuel

**Notes:**

USSR

## BRDM-3

LCV

Comnder

Driver

Gunner

Loader

Functional

Functional

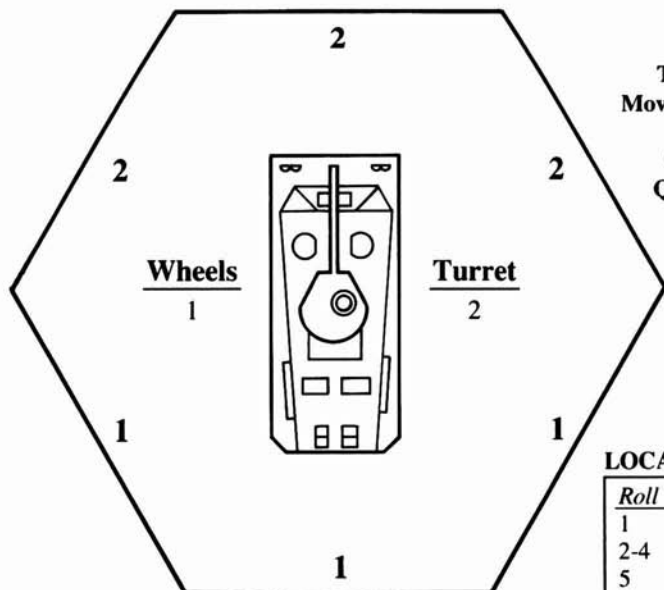

ID#: \_\_\_\_\_  
 Crew: 4  
 Troops: 0  
 Movement: 7/3  
 RF: \_\_\_\_\_  
 Troop Quality: \_\_\_\_\_

## ARMAMENT CHART

<i>Weapon</i>	<i>Antivehicle</i>	<i>Antipersonnel</i>
30mm Autocannon	12, 10	3, 10
PK MG	—	2, 5

## LOCATION CHART

<i>Roll</i>	<i>Hit</i>
1	Treads
2-4	Body
5	Turret
6	Miss

**TURRET**  
 Minor

<i>Roll</i>	<i>Hit</i>
1	RF
2-3	PK MG
4	Gunner
5	Loader
6	Major Turret

## Major

<i>Roll</i>	<i>Hit</i>
1-3	30mm Autocannon
4-5	Gunner & PK MG
6	Minor Body

**BODY**  
 Minor

<i>Roll</i>	<i>Hit</i>
1	Commander
2-3	Driver
4	Radio
5-6	Major Body

## Major

<i>Roll</i>	<i>Hit</i>
1-4	Engine
5-6	Fuel

Notes:

USSR

**BTR-70/80**

APC

Comnder

Driver

Gunner

Troops

Troops

Functional

Functional

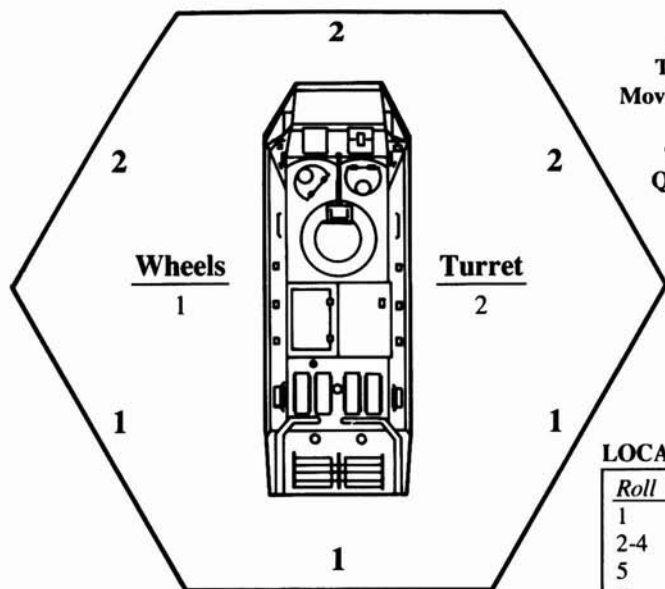

ID#: \_\_\_\_\_  
 Crew: 3  
 Troops: 14  
 Movement: 6/3A  
 RF: None  
 Troop Quality: \_\_\_\_\_

**ARMAMENT CHART**

<i>Weapon</i>	<i>Antivehicle</i>	<i>Antipersonnel</i>
PK MG	—	2, 5
KPV MG	4, 6	2, 8

**LOCATION CHART**

<i>Roll</i>	<i>Hit</i>
1	Wheels
2-4	Body
5	Turret
6	Miss

**TURRET  
Minor**

<i>Roll</i>	<i>Hit</i>
1-2	Gunner
3-5	KPV MG
6	Major Turret

**Major**

<i>Roll</i>	<i>Hit</i>
1-4	Gunner & KPV MG
5-6	Minor Body

**BODY  
Minor**

<i>Roll</i>	<i>Hit</i>
1	Commander & PK MG
2	Driver
4-5	Troops
6	Major Body

**Major**

<i>Roll</i>	<i>Hit</i>
1-4	Engine
5-6	Fuel

**Notes:**

**USSR****Mi-17 'Hip'****Transport Helicopter**

Pilot

Copilot/  
Gunner

Troops

Troops

Functional

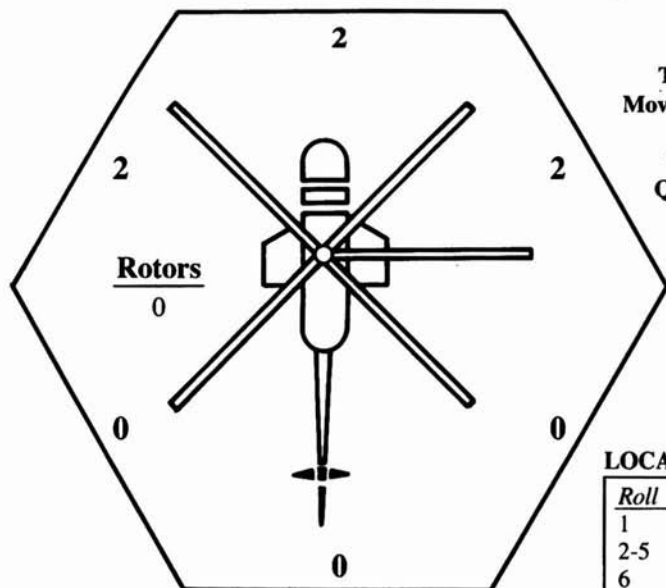

ID#: \_\_\_\_\_  
 Crew: 2  
 Troops: 24  
 Movement: 34/20  
 RF: \_\_\_\_\_  
 Troop  
 Quality: \_\_\_\_\_

**ARMAMENT CHART****LOCATION CHART**

<i>Roll</i>	<i>Hit</i>
1	Rotors***
2-5	Fuselage
6	Miss

<i>Weapon</i>	<i>Antivehicle</i>	<i>Antipersonnel</i>
UV-16-57 Rockets	15, 16	5, 16

**FUSELAGE****Minor**

<i>Roll</i>	<i>Hit</i>
1	RF
2-3	Copilot/Gunner
4-5	Troops/Cargo
6	Major Fuselage

**Major**

<i>Roll</i>	<i>Hit</i>
1	UV-16-57*
2	Pilot
3-4	Engine**
5-6	Fuel

**Notes:** \*If this is hit, roll a 25 attack on helicopter's fuselage. \*\*Engine Hits: Pilot must land helicopter within the hex of the place he takes damage. \*\*\*Rotors: The pilot must roll a 1 (modified by troop quality) in order to land the helicopter, otherwise it crashes. *Escaping from Crash:* See Escaping From Destroyed Vehicles.

USSR

T-72/80

MBT

Comnder

Driver

Gunner

ID#: \_\_\_\_\_  
 Crew: 3  
 Troops: 0  
 Movement: 4/3  
 RF: \_\_\_\_\_  
 Troop Quality: \_\_\_\_\_

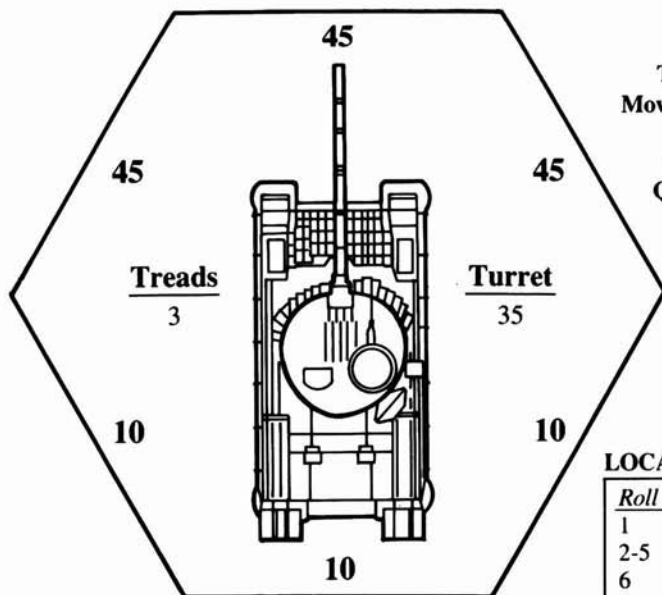

## LOCATION CHART

Roll	Hit
1	Treads
2-5	Body
6	Turret

## ARMAMENT CHART

Weapon	Antivehicle	Antipersonnel
125mm	70, 20	4, 16
DShK	3, 6	2, 6
PK MG	—	2, 5

Functional

Functional

Functional

**TURRET**  
 Minor

Roll	Hit
1-2	DShK
3	PK MG
4	Commander
5	RF
6	Major Turret

## Major

Roll	Hit
1-2	125mm
3	Commander & Gunner
4-5	Ammo
6	Minor Body

**BODY**  
 Minor

Roll	Hit
1-2	Driver
3	Radio
4-5	Commander
6	Major Body

## Major

Roll	Hit
1-3	Engine
4	Fuel
5-6	Ammo

**Notes:** The T-72/80 has particularly effective tread skirts which protect the treads.

**USSR****T-90****MBT**

Comnder
---------

Driver
--------

Gunner
--------

ID#: \_\_\_\_\_  
 Crew: 3  
 Troops: 0  
 Movement: 4/3  
 RF: \_\_\_\_\_  
 Troop Quality: \_\_\_\_\_

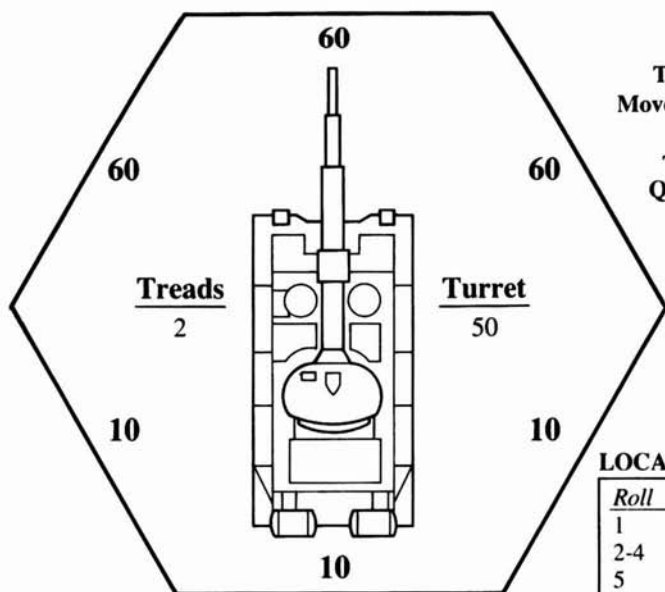
**LOCATION CHART**

Roll	Hit
1	Treads
2-4	Body
5	Turret
6	Miss

**ARMAMENT CHART**

Weapon	Antivehicle	Antipersonnel
125mm	70, 20	4, 16
PK MG	—	2, 5
DShK	3, 6	2, 6

Functional
------------

Functional
------------

Functional
------------

**TURRET**  
Minor

Roll	Hit
1	PK MG
2-3	Autoloader*
4	RF
5-6	Major Turret

**Major**

Roll	Hit
1-4	125mm
5-6	Major Body

**BODY**  
Minor

Roll	Hit
1	Radio
2	DShK
3	Driver
4	Gunner
5	Commander
6	Major Body

**Major**

Roll	Hit
1-2	Engine
3-4	Ammo
5-6	Fuel

**Notes:** The T-90 has an autoturret; no crew ride inside of it, and the 125mm ammunition is fed to the gun from inside the body of the tank via an autoloader. \*The autoloader has been hit. Each attack phase roll a die: 1-2, the 125mm may fire; 3-6, it is jammed.

USSR

# UAZ-469

Comnder/  
Gunner

Driver

Troops

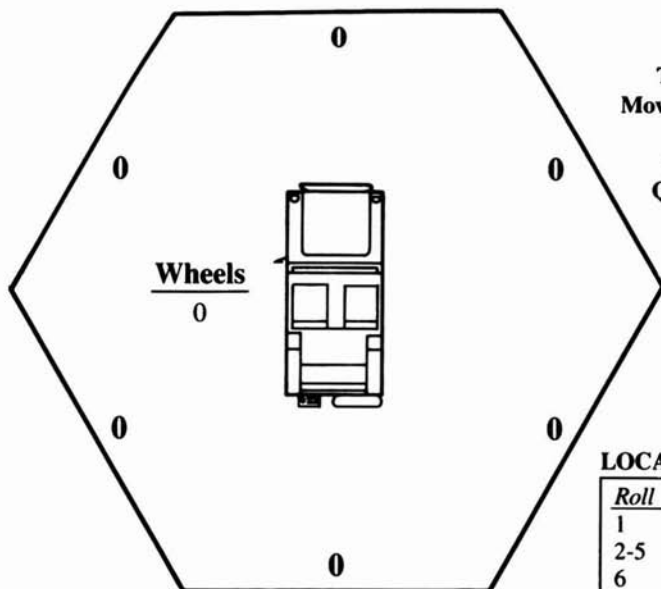

ID#: \_\_\_\_\_  
 Crew: 2  
 Troops: 6  
 Movement: 7/3  
 RF: \_\_\_\_\_  
 Troop Quality: \_\_\_\_\_

## LOCATION CHART

<i>Roll</i>	<i>Hit</i>
1	Wheels
2-5	Body
6	Miss

One of the following weapons may be mounted on a UAZ-469:

Weapon Mounted

GPMG  
AGL

## BODY

### Minor

<i>Roll</i>	<i>Hit</i>
1	Driver
2	Comnder/Gunner
3	Troops/Cargo
4	Weapon
5	Radio
6	Major Body

### Major

<i>Roll</i>	<i>Hit</i>
1-4	Engine
5-6	Fuel

Notes:

1 2 2	001 1 2	1 2 2	002 1 2	1 2 2	003 1 2	1 2 2	004 1 2	1 2 2	005 1 2	1 2 2	006 1 2	1 2 2	007 1 2
1 2 2	008 1 2	1 2 2	009 1 2	1 2 2	010 1 2	2 2 2	011 1 2	2 2 2	012 1 2	2 2 2	013 1 2	2 2 2	014 1 2
2 2 2	015 2 2	2 2 2	016 2 2	4 2 2	017 2 2	4 2 2	018 2 2	4 2 2	019 2 2	4 2 2	020 2 2	4 2 2	021 2 2
4 2 2	022 2 2	4 2 2	023 2 2	4 2 2	024 2 2	4 2 2	025 2 2	4 2 2	026 2 2	6 2 2	027 2 2	6 2 2	028 2 2
6 2 2	029 2 2	6 2 2	030 2 2	6 2 2	031 2 2	1/2 0 2	032 1 2	1/2 0 2	033 1 2	1/2 0 2	034 1 2	1/2 0 2	035 1 2
1/2 0 2	036 1 2	1/2 0 2	037 1 2	1/2 0 2	038 1 2	1/2 0 2	039 1 2	1/2 0 2	040 1 2	1/2 0 2	041 1 2	1 0 2	042 1 2
1 0 2	043 1 2	1 0 2	044 1 2	1 0 2	045 1 2	1 0 2	046 1 2	1 0 2	047 1 2	2 0 2	048 1 2	1 0 2	049 1 2
1 0 2	050 1 2	1 0 2	051 1 2	1 0 2	052 1 2	2 0 2	053 1 2	2 0 2	054 1 2	1 1 2	055 1 2	1 1 2	056 1 2
1 1 2	057 1 2	1 1 2	058 1 2	1 1 2	059 1 2	1 1 2	060 1 2	1 1 2	061 1 2	2 1 2	062 1 2	2 1 2	063 1 2
2 1 2	064 1 2	2 1 2	065 1 2	2 1 2	066 1 2	4 1 2	067 1 2	4 1 2	068 1 2	4 1 2	069 1 2	4 1 2	070 1 2
6 1 2	071 1 2	1/2 3 2	072 1 2	1/2 3 2	073 1 2	1/2 3 2	074 1 2	1/2 3 2	075 1 2	1/2 3 2	076 1 2	1/2 3 2	077 1 2
1/2 3 2	078 1 2	1 3 2	079 1 2	1 3 2	080 1 2	1 3 2	081 1 2	2 3 2	082 1 2	2 3 2	083 1 2	Dummy	
Dummy	Dummy	Dummy	Dummy	Dummy	Dummy	Dummy	Dummy	Dummy	Dummy	Dummy	Dummy	Dummy	Dummy
3 3 3	084 3 3	3 3 3	085 3 3	3 3 3	086 3 3	3 3 3	087 3 3	3 3 3	088 3 3	3 3 3	089 3 3	3 3 3	090 3 3
3 3 3	091 3 3	3 3 3	092 3 3	3 3 3	093 3 3	3 3 3	094 3 3	3 3 3	095 3 3	3 3 3	096 3 3	3 3 3	097 3 3
3 3 3	098 3 3	3 3 3	099 3 3	Bridge	Bridge	2 5 5	GPMG M60	2 5 5	GPMG M60	2 5 5	GPMG M60		

1 2 2	101 1 2	1 2 2	102 1 2	1 2 2	103 1 2	1 2 2	104 1 2	1 2 2	105 1 2	1 2 2	106 1 2	1 2 2	107 1 2	1 2 2	108 1 2		
1 2 2	109 1 2	1 2 2	110 1 2	2 2 2	111 2 2	2 2 2	112 2 2	2 2 2	113 2 2	2 2 2	114 2 2	2 2 2	115 2 2	2 2 2	116 2 2		
4 2 2	117 2 2	4 2 2	118 2 2	4 2 2	119 2 2	4 2 2	120 2 2	4 2 2	121 2 2	4 2 2	122 2 2	4 2 2	123 2 2	4 2 2	124 2 2		
4 2 2	125 2 2	4 2 2	126 2 2	6 2 2	127 2 2	6 2 2	128 2 2	6 2 2	129 2 2	6 2 2	130 2 2	6 2 2	131 2 2	1/2 0 2	132 1 2		
1/2 0 2	133 1 2	1/2 0 2	134 1 2	1/2 0 2	135 1 2	1/2 0 2	136 1 2	1/2 0 2	137 1 2	1/2 0 2	138 1 2	1/2 0 2	139 1 2	1/2 0 2	140 1 2		
1/2 0 2	141 1 2	1 0 2	142 1 2	1 0 2	143 1 2	1 0 2	144 1 2	1 0 2	145 1 2	1 0 2	146 1 2	1 0 2	147 1 2	0 0 2	148 4 2		
1 0 2	149 1 2	1 0 2	150 1 2	1 0 2	151 1 2	1 0 2	152 1 2	2 0 2	153 1 2	2 0 2	154 1 2	1 0 2	155 1 2	1 0 2	156 1 2		
1 1 2	157 1 2	1 1 2	158 1 2	1 1 2	159 1 2	1 1 2	160 1 2	1 1 2	161 1 2	2 1 2	162 1 2	2 1 2	163 1 2	2 1 2	164 1 2		
2 1 2	165 1 2	2 1 2	166 1 2	4 1 2	167 1 2	4 1 2	168 1 2	4 1 2	169 1 2	4 1 2	170 1 2	6 1 2	171 1 2	1/2 3 2	172 1 2		
1/2 3 2	173 1 2	1/2 3 2	174 1 2	1/2 3 2	175 1 2	1/2 3 2	176 1 2	1/2 3 2	177 1 2	1/2 3 2	178 1 2	1 3 2	179 1 2	1 3 2	180 1 2		
1 3 2	181 1 2	2 3 2	182 1 2	2 3 2	183 1 2	Dummy	Dummy	Dummy	Dummy	Dummy	Dummy	Dummy	Dummy	Dummy	Dummy		
Dummy	Dummy	Dummy	Dummy	Dummy	Dummy	Burning Wreck	Burning Wreck	Burning Wreck	Burning Wreck	Burning Wreck	Burning Wreck	Burning Wreck	Burning Wreck	Burning Wreck	Burning Wreck		
Burning Wreck	Burning Wreck	Burning Wreck	Burning Wreck	Burning Wreck	Burning Wreck	Mobility Damage	Mobility Damage	Mobility Damage	Mobility Damage	Mobility Damage	Mobility Damage	Mobility Damage	Mobility Damage	Mobility Damage	Mobility Damage		
Mobility Damage	Mobility Damage	Mobility Damage	Mobility Damage	Mobility Damage	Mobility Damage	Radio Damage	Radio Damage	Radio Damage	Radio Damage	Radio Damage	Radio Damage	Radio Damage	Radio Damage	Radio Damage	Radio Damage		
Radio Damage	25 6	ATRL RPG-16	25 6	ATRL RPG-16	25 6	ATRL RPG-16	20 4	ATRL Armbit	3 6	2 6	AGL AGS-17	2 6	3 6	HMG DSHK	6 8	5 8	AGL Mark-13
2 5	GPMG M60	2 5	GPMG M60	2 5	GPMG M60	30 80	ATGM Tankbr		40 140	ATGM Tow II	30 80	ATGM AT-4	2 6	3 6	HMG M2HB		





M1	201	M1	202	M1A1	203	M1A1	204	M1A2	205	M113	217	M113	218	M113	ACCV	219
5	4	5	4	5	4	5	4	5	4	4	3A	4	3A	4	3A	4
M1A2	206	M2	207	M2	208	Leopard II	209	M60A4	210	HMMWV	220	HMMWV	221	HMMWV	222	
5	4	5	4A	5	4A	5	4	5	3	7	4	7	4	7	4	
Stringray	211	Stringray	212	LAV-25	213	LAV-25	214	LAV-75	215	Truck	226	Truck	227	Truck	228	
5	4	5	4	6	4A	6	4A	6	4	6	3	6	3	6	3	
T-90	301	T-90	302	T-72/80	303	T-72/80	304	Tank	216	APC	229	BRDM-3	315	BRDM-3	316	
4	3	4	3	4	3	4	3			7	3	7	3	7	3	
T-72/80	305	T-72/80	306	BTR-70/80	307	BTR-70/80	308	BTR-70/80	309	UAZ-469	317	UAZ-469	318	Truck	319	
4	3	4	3	6	3A	6	3A	6	3A	7	3	7	3	6	3	
BMP-B/C	310	BMP-B/C	311	BMD-B	312	Mi-17	313	Tank	314	Truck	320	Truck	321	APC	322	
5	3A	5	3A	6	3A	34	20			6	3	6	3			
										Hiding	Hiding	Hiding	Hiding	Hiding	Hiding	
										Hiding	Hiding	Hiding	Hiding	Hiding	Hiding	

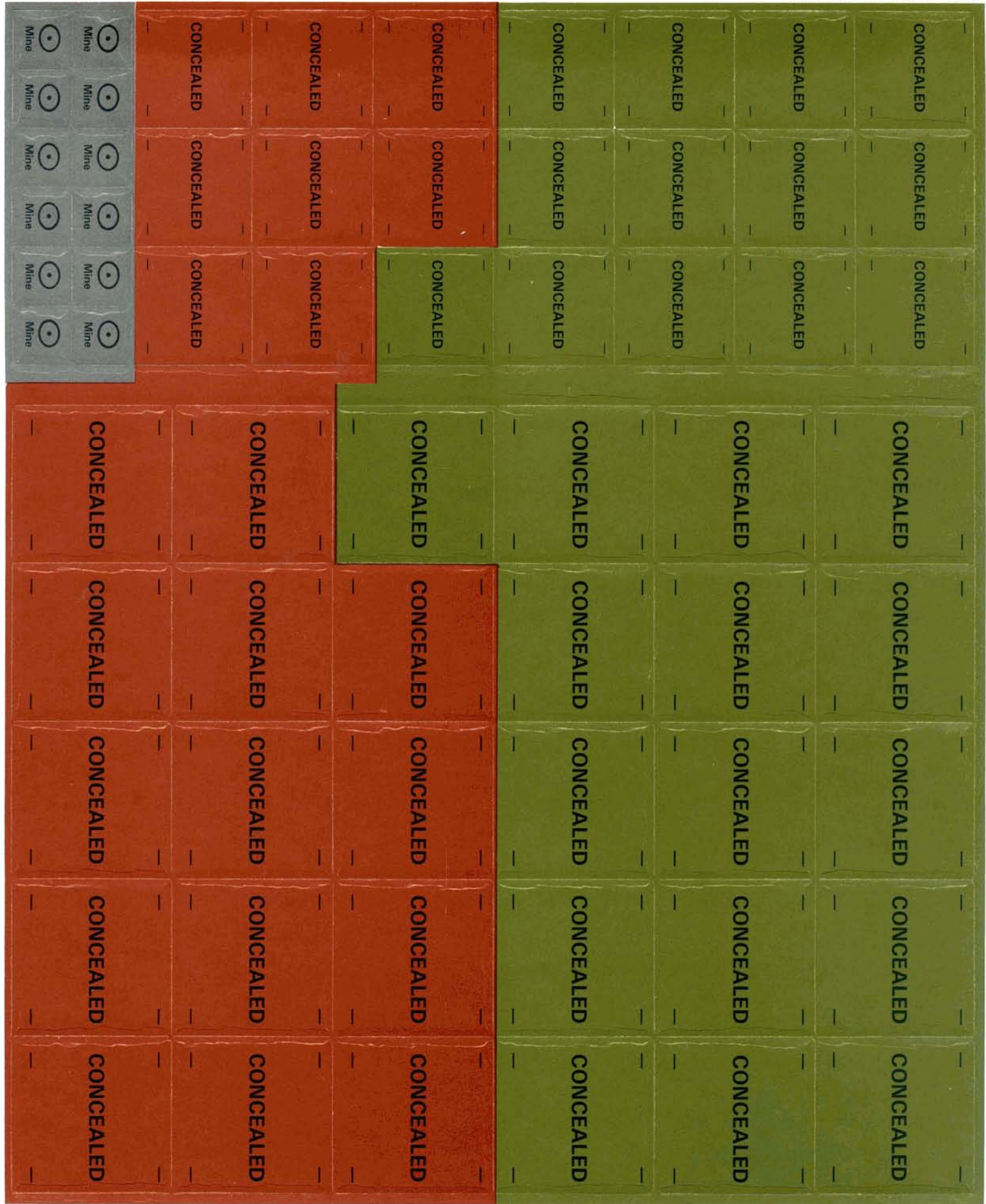

## Complete Man-to-Man, Tank-to-Tank Boardgame for Battles in World War III

Easy-to-Learn, Fun-to-Play  
Combat Resolution System  
for Twilight: 2000

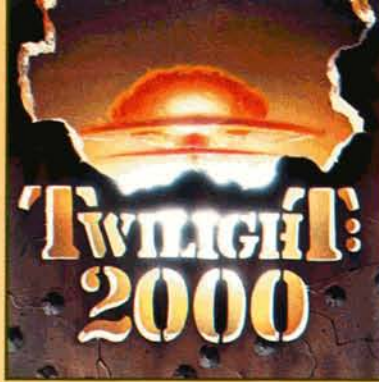

# LAST BATTLE™

## World War III

Every nation of Earth has been drawn into a global contest. What is different this time is the sophisticated technology of the tanks, aircraft, personal weapons, and particularly the nuclear missiles.

**Last Battle** is the ultimate simulation of immediate post-holocaust warfare. Tattered remnants of armies fight for survival in war-ravaged Europe. Cities have been leveled; entire armies have been destroyed; governments have fallen. Small groups of soldiers, separated from their chain of command and supply lines, rely on training and what remains of their sophisticated weapons to fight the last battle.

## Special Rules

Detailed Vehicle Damage  
Armored Vehicles  
Soft-Skinned Vehicles  
Leadership and Cohesion Rules



Made in U.S.A.  
Printed in U.S.A.

ISBN 1-55878-017-3

Copyright©1989 GDW.  
PO Box 1646, Bloomington, IL 61702.  
All rights reserved.  
Twilight: 2000, Last Battle, and First Battle  
are Trademarks of GDW, Inc.

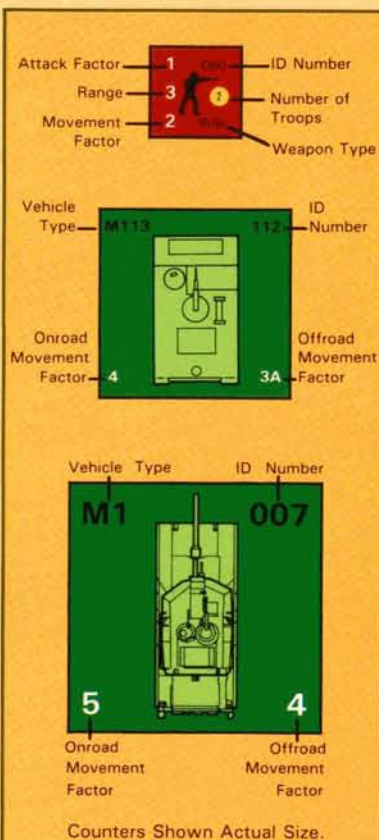

## Components

252 Small Counters  
21 Medium Counters  
30 Large Counters  
Rules Book  
Scenarios Book  
64 Vehicle Cards  
6 Geomorphic Maps  
2 Six-Sided Dice



PO Box 1646  
Bloomington, IL 61702-1646

## Two Distinct Games

- A system for resolving combat in the role-playing game **Twilight: 2000**.

- A stand-alone boardgame.

As a **Twilight: 2000** boardgame, **Last Battle** quickens vehicle and troop combat resolution while preserving the detail and flavor which has made the role-playing game so popular. As a complete, stand-alone boardgame, **Last Battle** is the ultimate simulation of immediate post-holocaust warfare.

NATO	M1	MBT	
Commander	60	ID#: 4	
Driver	60	Crew: 4	
Gunner	8	Troops: 0	
Loader	8	Movement: 5.4	
Functional	8	RF: 1	
Functional	8	Troop Quality: 1	
Functional	8		
<b>ARMAMENT CHART</b>			
	Weapon	Antivehicle	Antipersonnel
Functional	105mm	60, 20	3, 16
Functional	MAG MG	—	2, 5
Functional	M2HB	3, 6	2, 6
		<b>TURRET</b>	<b>BODY</b>
		Minor	Minor
Roll Hit	1	Commander	1
Roll Hit	2	RF	2
Roll Hit	3	Gunner	3
Roll Hit	4	MAG MG	4
Roll Hit	5	M2HB	5
Roll Hit	6	Major Turret	6
		Major	Major
Roll Hit	1	Commander & Gunner	1-2
Roll Hit	2	Gunner & Loader	3-4
Roll Hit	3-4	105mm	5-6
Roll Hit	5	Ammo*	
Roll Hit	6	Minor Body	
Roll Hit	1-2	Engine	
Roll Hit	3-4	Fuel	
Roll Hit	5-6	Ammo*	

Notes: \*The M1 has blow-out ports in case the 105mm ammunition detonates inside the vehicle. Roll a die 1-4, no ammo for the 105mm; 5-6, vehicle destroyed.

Sample Vehicle Card—Actual Size 5 1/2" X 8 1/2"