

POLISH ARMY SOURCEBOOK

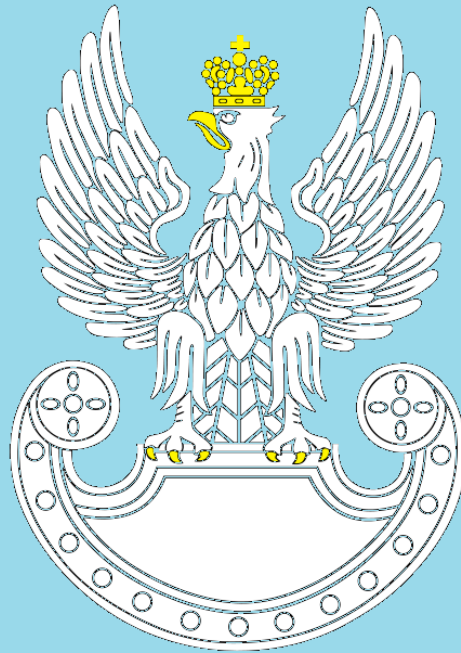

Twilight:2000

Wojska Lądowe

Sourcebook

Designs by Paul Mulcahy



Copyright © Anders Larsson 2009 All Rights Reserved. No part of this document may be reproduced without written consent from the author.

The Twilight 2000 game in all forms is owned by Far Future Enterprises. Copyright 1983 - 2008 Far Future Enterprises. Twilight 2000 is a registered trademark of Far Future Enterprises. Far Future permits web sites and fanzines for this game, provided it contains this notice, that Far Future is notified, and subject to a withdrawal of permission on 90 days notice. The contents of this document are for personal, non-commercial use only. Any use of Far Future Enterprises's copyrighted material or trademarks anywhere in this document should not be viewed as a challenge to those copyrights or trademarks. In addition, any text or images used in this document cannot be republished or distributed without the consent of the author who contributed it.

Fair Use Notice

This document may contain copyrighted material the use of which has not been specifically authorized by the copyright owner. This work makes use of such material available in our efforts to advance understanding of environmental, political, human rights, economic, democracy, scientific, and social justice issues, etc. This work is for non-profit and educational purposes only and is of a purely non-commercial nature.

The drafters of the document believe this constitutes a 'fair use' of any such copyrighted material as provided for in section 107 of the US Copyright Law. In accordance with Title 17 U.S.C. Section 107, the material in this document distributed without profit to those who have expressed a prior interest in receiving the included information for research and educational purposes. If you wish to use copyrighted material from this site for purposes of your own that go beyond 'fair use', you must obtain permission from the copyright owner.

GNU Materiel Notice

Material sourced from Wikipedia is licensed under the GNU Free Documentation License. The work contains material from numerous Wikipedia articles found at <http://en.wikipedia.org/wiki/Wikipedia>

CHAPTER 1 MILITARY HISTORY

IN THE EARLY 1990s, Poland addressed its national security issues as an independent state for the first time in more than fifty years. The loss and restoration of independence, and the fluctuations of national security that accompany such trauma, were not unusual in Polish history, however. When it was included in the Soviet Union's new empire after World War II, Poland lost control of its national security for the second time in two centuries. After functioning as two separate entities during the war, the Polish military was consolidated after the war as a subordinate component of a multinational military organization devoted primarily to defense of the Soviet Union. Following the Soviet model, the Polish communist government also established strong military-style internal security forces to protect the regime from internal and external threats.

In 1989 Poland's communist government fell unexpectedly after several decades of civil unrest that periodically had brought the threat of punitive intervention by the Soviet Union. The ensuing political chaos forced Poland to develop a new doctrine of national defense emphasizing cooperation with Western military and security organizations and friendly relations with previously hostile neighbor states. By 1991 the Warsaw Treaty Organization, better known as the Warsaw Pact, the multinational military structure created by the Soviet Union to dominate its East European empire, also had crumbled.

Poland's new doctrine developed slowly and fitfully in the first years of the 1990s. The country's economic need to trim its defense establishment clashed with perceptions of possible new threats and alliances in post-communist Europe. After emerging from the Warsaw Pact, Poland found itself without military alliances at the same time as its military infrastructure was rapidly decaying. In this setting, harsh budget restrictions caused alarm that national security again might be compromised before restructuring and rearmament could take place.

Poland's location between two powerful neighbors, Germany and Russia, had influenced the country's national security for centuries. By the early 1990s, however, the changing political circumstances of the region had mitigated Polish concerns about German or Russian aggression for the foreseeable future. Beginning in 1990, Germany's attention was largely absorbed by the massive problems of reunification. The disintegration of the Soviet Union at the end of 1991 enabled the nations of Lithuania, Belarus, and Ukraine to emerge as newly independent states on Poland's eastern border. Thus, in less than three years the number of countries on Poland's borders increased from three to six. Under those circumstances, Poland was concerned about a security vacuum that might promote internal instability, border disputes, or even an armed regional conflict close to Polish territory. Poland's national security depended not only on the stability of neighboring states but also on domestic political and economic stability.

A healthy military was important for two reasons. Historically, the army had represented Polish self-esteem and the survival of the

Polish state. National leaders were anxious to recapture that tradition to boost domestic morale. Also, a capable military establishment would help Poland present itself to the world as a viable, independent state. To achieve these goals, Polish leaders sought a complete restructuring of the defense establishment in the early 1990s. A new national military doctrine was formulated to reflect the end of the Warsaw Pact and the end of the political and military division of Europe into rival camps, as well as Poland's possible inclusion in existing Western security structures. The reform program was intended to streamline the Ministry of National Defense and military administration and to include civilians more closely in the process of defense decision making. The reform program sought to extricate the Polish Army from the constraints of Soviet dominated Warsaw Pact military doctrine and training standards. Reform leaders also sought to reestablish the prestige of the armed forces as a national institution separate from and above politics. The quasi-military forces that the Ministry of Internal Affairs had used to quell civil unrest during the communist era were abolished or redirected against genuine threats to the welfare of society.

The Communist Era and Postwar Consolidation



Partisan forces of the Polish Home Army

For forty-five years following World War II, the Polish military subordinated its organization and its doctrine to the larger geopolitical and military aims of the Soviet Union. Until 1981, however, Polish society largely retained the traditional notion that the first mission of its army was to represent and defend the Polish people, regardless of political conditions. The final eight years of communist rule marked an unnatural combination of military and political doctrines, triggering a reorganization process that continued into the noncommunist 1990s.

The noncommunist Home Army officially disbanded in January 1945, and the course of the war left the eastern front armies in control of all Polish territory. In the immediate postwar era, the army took second place to Poland's new internal security forces in

purging political opponents and consolidating communist power. This purging process lasted until the formation of the Polish United Workers' Party (*Polska Zjednoczona Partia Robotnicza*—"PZPR") in 1948.



Polish Cavalry at the outbreak of World War II

Unlike other important institutions, the army did not suffer wholesale purges of its noncommunist elements in the immediate postwar period. Communists controlled the top ranks and leadership positions, however, and political commissars installed in military units taught communist party principles to regular soldiers and ensured their loyalty to the party. Many wartime political officers played a significant role in the indoctrination process and based glittering civilian careers on their contributions to the building of the communist state.

In the late 1940s, the main roles of the military were resettlement of Poland's newly acquired western territory, helping in economic reconstruction, and waging a three-year civil war against former Home Army supporters, Ukrainian nationalists, and various outlaw bands in the foothills of the Carpathian Mountains. Some 70,000 people were arrested by internal security and military authorities in the repression of civil uprisings between 1945 and 1948. In 1981 General Wojciech Jaruzelski, who later would head the last communist government, cited the threat that such uprisings would recur in his rationale for imposing martial law in Poland.

The sociological composition of Poland's army changed dramatically after World War II. The interwar officer corps had come mostly from the gentry and professional classes. By 1949, however, only 29 percent of Polish officers had begun service before the war, and peasants and workers were favored highly in postwar officer training programs. From 1948 through 1953, in keeping with Stalin's intrusive totalitarian influence throughout Eastern Europe, the PZPR and the Soviet Army exercised increasing influence in Polish military affairs. Soviet officers headed the Polish General Staff, all service branches, and all military districts during this period. A Soviet general, Konstantin Rokossovskii, served as minister of defense of Poland between 1949 and 1956. His first assignment was to purge the Polish armed forces of remaining prewar personnel who were considered ideologically unreliable. Accordingly, between 1950 and 1955, many faithful communist officers were imprisoned or executed. In 1949, as the Cold War set in, the Polish People's Army (as it was renamed after World War II) went on a war footing, conscription was reinstated, and preparations were made to operate as part of the Soviet army in a future European land war.

The ravages of World War II somewhat eroded society's faith in the Polish military's ability to defend the country. Postwar politicization caused a further decline in the military's stature and a parallel decline in military morale and organization. Soviet army officers in close cooperation with the Committee for State Security (*Komitet gosudarstvennoi bezopasnosti*—"KGB") occupied all key commands until 1956. This command structure bypassed Polish communist authorities often and openly in making military policy.



Polish, Soviet, GDR and Hungarian officers.

In June 1956, major failures of communist state economic policy brought a large-scale uprising of workers in Pozna demanding

"bread and freedom." Polish troops refused to fire on the workers, heralding a political upheaval that ended the Stalinist era in Poland. The uprisings of 1956 greatly alarmed the Soviet Union and ultimately reduced Soviet control over the Polish military and internal security agencies. Poland's Security Service (*Sluzba Bezpieczenstwa*—"SB"), which had crushed the Pozna workers ruthlessly, was revamped in 1956. The widely unpopular Rokossovskii and thirty-two Soviet generals were recalled to the Soviet Union in spite of intense Soviet diplomatic pressure. At this critical point, Polish units went on alert in response to a massing of Soviet troops and tanks on the eastern border. Incoming party chief Wladyslaw Gomulka skillfully negotiated Poland's position with the Soviets; backed by Poland's demonstrated willingness to defend itself, Gomulka was able to avert an invasion. Just two weeks later, in October 1956, Soviet tanks would roll into Hungary. The Moscow Declaration and the Treaty of December 17, 1956 then stipulated the sovereignty of the Polish communist elite over the Polish military and established limitations on the stationing and maneuver of Soviet forces in Poland.



Warsaw Pact era Polish Tankers

Many of Gomulka's reforms proved short-lived, however, and no full offensive was mounted against Soviet control of the military. In his campaign against "revisionism," which began in 1957, Gomulka gradually returned pro-Moscow officers to key positions. Moscow continued to station troops in Poland, train Polish officers in the Soviet Union, supply Soviet-made weapons, and include Poland in regional defense plans. And in 1957, Gomulka formed the Military Counterintelligence Service to continue supplying the party information about political attitudes in the military. At the same time, he refined and professionalized the Internal Security Corps, which had been discredited in 1956. Political officers received training to give them a higher level of professional military competence and credibility with the troops and their professional counterparts. Nevertheless, experts consider the events of 1956 a watershed in Polish military history. Because Polish forces had helped the Polish communist government to a new autonomy, the military regained some of its prestige and influence in society.

Gomulka's government sought to consolidate PZPR control of military policy, which in the Stalinist years had been a tangled combination of informal Polish and Soviet lines of authority. Gomulka replaced departing Soviet commanders with Polish officers who had served with him in the wartime communist

underground (as opposed to the Soviet-controlled Polish First Army) and with commanders who had prepared their troops to resist the threatened Soviet invasion in 1956. Nominal control of military affairs rested with the Council of Ministers and its National Defense Committee (*Komitet Obrony Kraju*—"KOK"). As in all other national policy matters, however, the Political Bureau (*Politburo*) of the PZPR had the final word in all important policy questions. Personalities and factions continued to dominate policy. Under Gomulka's trusted minister of national defense, General Marian Spychalski, the top grades of the officer corps were riven by political conflict. A conservative nationalist group known as the Partisans became a major force opposing military and political reform. Their leader, internal security chief Mieczyslaw Moczar, gained substantial power in the 1960s by playing factions against one another and purging reformist rivals. In 1967-68, using the June 1967 War between Israel and its Arab neighbors as a pretext, Moczar and his faction instigated the purge of the remaining 200 Jewish officers in the Polish People's Army and the ouster of Spychalski. Moczar's methodology did not yield him complete control, however, because most of the purged officers were replaced by young professionals uninterested in the ideological infighting of the military establishment.

One such figure was Wojciech Jaruzelski, the lieutenant general who capped a rapid rise through the ranks by replacing Spychalski as minister of national defense in 1968. Jaruzelski's appointment began the retreat of the Partisans' influence. In 1970 the military again was ordered to quell worker riots, this time in the Baltic ports of Gdansk and Gdynia. Jaruzelski refused to transmit the order, and the army generally refrained from action. Although army units inflicted some civilian casualties, the Internal Security Corps again was the main force brought against Polish demonstrators. The army's reaction reinforced the message of 1956 that the Polish military could not be expected to defend a communist regime from the people by suppressing political unrest.

In the 1970s, the prestige of the military continued to grow while that of the PZPR plummeted because of the economic failures and corruption associated with the regime of Gomulka's successor, Edward Gierek. Through the 1970s and the 1980s, the military took a noncommittal attitude toward major episodes of civil unrest. In 1976 Minister of National Defense Jaruzelski informed Gierek that Polish soldiers could not be expected to fire on striking Polish workers. The army remained strictly loyal to the communist system, but it showed much less loyalty to particular regimes when they came under attack from the Polish population. In 1980, when the Solidarity (*Solidarnosc*) union set off a series of large-scale strikes in the Baltic ports, the government apparently did not consider using the military to quell unrest. A 1981 poll showed the military behind only the church and Solidarity in the level of respect afforded by Poles to their national institutions.



Polish troops of the 6th Air Assault division on a joint exercise with Soviet troops in the late 1970's

While the Polish military remained neutral in internal affairs, it fulfilled completely the foreign duties expected of a Warsaw Pact member. Two Polish divisions took part in the 1968 invasion of Czechoslovakia that was precipitated by Soviet alarm at that country's experimentation with economic and political reform. In keeping with the Soviet Union's decision to distribute defense responsibilities more widely among Warsaw Pact members, the Polish defense industry grew rapidly in the 1970s and early 1980s. Poland reached fifth place in world arms exports in 1987.

Martial Law

Although the military was taking a low public profile, Jaruzelski played a major behind-the-scenes role in unseating the discredited Gierek in 1980. The following year, Jaruzelski himself became prime minister as a compromise candidate acceptable to all factions of the PZPR's divided leadership. By 1981 military officers occupied fourteen seats in the PZPR Central Committee (three had been the norm during the Gierek regime). Until late 1981, Jaruzelski represented a moderate wing of the PZPR willing to negotiate with the ever-more powerful Solidarity movement. The restraint Jaruzelski had shown in using military force in 1970, 1976, and 1980 sustained his public prestige and that of the armed forces through 1980.



A Solidarity march in Warsaw, 1980

In 1981, however, the near-collapse of the PZPR caused civilian party leaders to tie the army, by way of Jaruzelski, closer to the role of defending the regime against popular dissent. Party leaders

named Jaruzelski prime minister and then first secretary of the PZPR, making the general the most powerful political figure in Poland and completely closing the gap between military and political authority. In December 1981, the party's continued collapse, the country's economic decay, and Solidarity's increasingly radical demands and fear of a Soviet Army invasion triggered by those conditions caused Jaruzelski to declare martial law, in effect executing a military coup.



ZOMO units enforce the 1981 declaration of Martial Law

The military was mobilized but did not confront activists and demonstrators directly. The army staffed checkpoints and protected communications and transportation facilities while the specialized Motorized Units of the Citizens' Militia (*Zmotoryzowane Oddziały Milicji Obywatelskiej*—"ZOMO") performed riot control functions on the streets. Nevertheless, martial law associated the military directly with the severe curtailment of civil liberties and the imprisonment of thousands of antigovernment activists. The use of the military to keep a Polish regime in power again tarnished the public perception of the armed forces. The prospect of facing fellow Poles in life-threatening confrontations fragmented and demoralized the army as well. Once the public regained its voice in government policy in 1989, the memory of martial law prompted strong insistence that control of the armed forces henceforth be distinctly lodged with responsible civilian officials and totally separate from any political party.

The state of emergency ended officially in mid-1983, but Jaruzelski and his military subordinates remained in control of top party and government offices for the next six years. Jaruzelski supporters replaced the discredited upper echelon of civilian PZPR officials, and during this period political officers remained in place at all levels of the military. Especially in the early and mid-1980s, the special police forces of the Ministry of Internal Affairs remained a potent arm of the government in suppressing dissident activity by surveillance and physical intimidation. The public's negative image of the military regime was reinforced in 1984 when Jaruzelski's government was implicated in the murder of dissident priest Jerzy Popiełuszko by internal security agents. After a unique public trial, the security service was reorganized, but dissidents still were harassed in the years that followed. During this period, military

recruitment became increasingly difficult because the declaration of martial law had reduced the prestige of a military career.

By 1985 Mikhail S. Gorbachev's highly visible reforms in the Soviet Union removed the rationale that political reform in Poland might incite an invasion from the East, and Jaruzelski moved cautiously in the same direction as Gorbachev. Shortly thereafter, the Soviet Union also orchestrated changes in Poland's international military position by restructuring the Warsaw Pact and revising the military doctrine that justified the alliance. When the Soviet Union began streamlining military planning and increasing doctrinal reliance on reserve forces throughout the alliance in 1987, Poland was able to begin sorely needed reductions in its military budget. In 1988 military personnel were reduced by 15,000 persons, and another 33,000 were cut in 1989. The military budget for 1989 was 4 percent less than that for 1988.

Transition and Reform

In 1989 the peaceful transition from the Jaruzelski regime to the popularly elected Solidarity-led government had little immediate impact on the organization of the Polish military. General Florian Siwicki, who had been Jaruzelski's minister of national defense, served in the first cabinet of noncommunist Prime Minister Tadeusz Mazowiecki, even though Siwicki had been closely involved in the 1968 invasion of Czechoslovakia and the imposition of martial law. Under Mazowiecki, Siwicki directed a first phase of military reforms until he was replaced in mid 1990. General Czesław Kiszczak, Jaruzelski's minister of internal affairs throughout the martial law period, also was held over in Mazowiecki's first cabinet. Kiszczak began redirecting the charter of the infamous special police services away from their traditional communist role of support for the government in power and toward protection of society as a whole.

In 1989, for the first time since the interwar period, the military came under open scrutiny by the Polish media and parliament. Public resentment of the armed forces as a tool of communist repression was increased by exposures of brutality and corruption under Jaruzelski. The military responded with a campaign of openness and humanization that finally led to substantial reform and reduced hostility between the military and Solidarity. Reform measures taken by the end of 1990 included removal of all political organizations from the military, further budget and manpower reductions, conversion of thirty military installations to civilian use, shortened terms of service for draftees, and freedom of religious practice in the military. Shortages of personnel already had forced passage of an alternative service law in 1988. Lech Walesa, the first popularly elected president, who came to power in December 1990, became commander in chief of the armed forces, and the Ministry of National Defense began a transition from a basically military body into a civilian agency of the government in which military authority would be distinctly subordinate).

Externally, Poland's chief military goal in the first post-communist years was ending the Warsaw Pact obligations that still placed Soviet troops on Polish soil in the early 1990s, then moving as quickly as possible to a new set of national security agreements. In 1990 Czechoslovakia, Hungary, and Poland began urging the dissolution of the Warsaw Pact, citing new geopolitical conditions

that made such an arrangement superfluous for the security of both the Soviet Union and the East European member nations.



Eastern Europe, 1995

In late 1990, the Poles then entered long and difficult bilateral negotiations on the Soviet troop issue, including the timing for withdrawal from Poland and the method by which Soviet troops leaving Germany would cross Polish territory. Soviet negotiators resisted an early timetable (Walesa's initial bargaining position required complete withdrawal by the end of 1991) and demanded compensation for installations that Soviet forces had built. The Soviet position on Poland was determined by existing agreements for complete Soviet withdrawal from Czechoslovakia and Hungary, and by the recent reunification of Germany. After those events, Poland was perceived as the last pillar of the Soviet Union's European security structure. The issue was finally resolved in late 1991 with Soviet agreement to remove all combat troops from Poland by the end of 1992 and all support troops by the end of 1993. A separate agreement defined terms for transit of Soviet troops from Germany through Poland.

CHAPTER 2 NATIONAL SECURITY POLICY

In mid-1991, the Warsaw Pact ceased to function as a military alliance, ending the dominating role of that organization in Polish national defense. Poland's approach to national security changed drastically, but the change really was a return to the geopolitical fundamentals that had formed the nation's long-term threat perception and military doctrine. Poland sought a new balance among its immediate neighbors (including Russia and Germany) and new security arrangements with other states, such as Hungary and the Czech and Slovak Federative Republic (CSFR--see Glossary), that were also emerging from Soviet domination. Like Poland, those nations now felt exposed on all sides. They were free to determine their own future, but they were also solely responsible for the results of their political and national security choices.

Threat Perception



By 1990 Polish centralized industry had produced over 8,000 T-55L tanks which were obsolete in the face of potential threats from the West.

Throughout the communist era, official threat perception by the Polish military was identical to that of the Soviet Union: the North Atlantic Treaty Organization would confront the forces of the socialist nations on the plains of Northern Europe in a massive conventional war. Until 1990 Poland had the special threat perception of renewed invasion from Germany; although the Federal Republic of Germany (West Germany) was itself a substantial military power, it was also the ostensible staging area for large numbers of NATO troops against the Warsaw Pact. On the other hand, the Soviet invasions of Czechoslovakia and Hungary exemplified the eastern threat perceived by both communist and noncommunist Poles with nationalist loyalties. That threat was also a convenient tool for the Jaruzelski government in justifying oppression of reform activity.

By 1987 the inefficient centralized industrial systems of the Warsaw Pact countries were increasingly unable to produce high-technology weaponry, and their national economies had become

severely distorted by the priority given military production. Accordingly, Gorbachev's "new thinking" on Soviet security prompted a redesign of Warsaw Pact strategy based on sober reassessment of Warsaw Pact resources and on the belief that political means could replace military strategy in protecting the security of the alliance. The new strategy included reducing defense spending and emphasizing a pan-European security plan that might split NATO into American and European factions. Although the new structure continued to regard Poland as a central player in the coalition defense system, Poland was able to reduce and streamline key military units beginning in 1987. Thus, before the revolutions of 1989, the Warsaw Pact's combined threat perception had changed pragmatically, and member nations had the opportunity to relieve somewhat the onus of mandatory support of the alliance's military structure. For Poland, this change triggered the search for a more realistic and independent threat perception that continued into the early 1990s.

The post-communist era complicated Poland's threat perception. The new outlook began with the recognition that Poland was not and could not be militarily comparable to its traditionally dangerous neighbors. To the east, the Soviet Union had fractured into numerous republics, abolishing any remaining threat of an attack launched from the east to keep Poland within ideological limits. The uneasy relations among the former Soviet republics, especially between Russia and Ukraine over issues such as jurisdiction over nuclear weapons and control of the Black Sea, caused alarm in Poland. So did the possibility that reform would fail in Russia, allowing an ultranationalist, hard-line regime to come to power, reassert Soviet or imperialist prerogatives, and renege on troop withdrawal schedules. Another threat was the rejection by the newly independent republics of arms control agreements signed by the Soviet Union. Such a move could lead to uncontrolled proliferation of nuclear weapons and the failure of limits on conventional forces in the region. In another scenario, central authority might fail entirely in former republics, causing conflicts among former Soviet forces to spill over onto adjacent Polish territory. In 1991 three events--the Soviet crackdown in Lithuania in January, the attempted reactionary coup in the Soviet Union in August, and the chaos of the Balkan wars in the last half of the year lent urgency to the formation of Poland's new European security policy.

Polish concerns were magnified by the strength and disposition of forces in the former East Germany. Russian troops withdrawn from Germany and Poland went to Kaliningrad, the isolated Russian province on Poland's northern border, and often remained there because the surrounding republics, Belarus and Lithuania, would not permit Russian troops to pass through their territory. The continued concentration of Russian armored, artillery, and infantry forces in Kaliningrad was a source of alarm for Poland in 1992. (Poland did not seek a change in the political status of Kaliningrad, however.) To the east, the armed forces in Ukraine's Carpathian Military District adjoining Poland exceeded Poland's entire combat

strength in 1994 (although bilateral relations with Ukraine were quite friendly). Many Polish storage depots were located close to the borders of both Kaliningrad and Ukraine, making them vulnerable in case of attack from either direction.

Past territorial and military conflicts with Belarus, Lithuania, and Ukraine were confined increasingly to the memories of the older generations on all sides. Nevertheless, Belarus, remembering that the Treaty of Riga had divided that republic between Poland and Soviet Russia in 1921, still claimed the Bialystok region of eastern Poland, which was home to a substantial Belarusian population. And Ukrainian nationalists remembered the role of the Polish People's Army in helping the Soviet Union crush the anticommunist Ukrainian Resistance Army in 1947, as well as the interwar Polish hegemony in western Ukraine. The most divisive issue in Polish-Lithuanian relations was treatment of the Polish minority in Lithuania, estimated at 300,000 people in 1990. In 1991 and 1992, that well-organized minority pressed for autonomy, putting the Polish government in a difficult diplomatic position and blocking Poland's efforts to secure its eastern and northern borders from ethnic turmoil.

Poland's evaluation of Germany's position was even less reassuring. In the early 1990s, Polish policy makers saw the newly reunified Germany's domination of NATO as a threat to Poland's territorial sovereignty. The German national outlook, and continued reemphasis of the German military were taken as indicators that Germany would remain a malignant neighbor through the 1990s. Poles increasingly perceived the threat from Germany as one of both economic and military domination. Accordingly, Poland's best defense appeared to lie in forming closer ties with the former members of the Warsaw Pact and strategic military planning. Doubts about Germany's long-term territorial goals were revived publicly in 1990 when Germany rejected the Oder-Neisse Line as a permanent border between the two countries and tensions were reinforced by Germany's refusal to sign a border treaty in late 1991.

Military Doctrine



Following the collapse of the Warsaw Pact, the Visegrád Group strengthened its military ties.

Throughout the existence of the Warsaw Pact, Poland was a key element in the security system of the Soviet Union. The Polish

armed forces were the largest non-Soviet national component of the alliance. Located in the "northern tier" between NATO countries and the Soviet Union, Poland was expected to play a major role in any major conventional conflict with West European forces. Polish force structure gave priority to armor in expectation of a blitzkrieg-style theater offensive across Europe. In joint offensive warfare training exercises in the early 1980s, Poland had the mission of attacking northern West Germany and Denmark. Poland was also the major corridor for supply and communications between the Soviet Union and the large Soviet force in place in the German Democratic Republic (East Germany). These factors were the rationale for the assignment of approximately 30,000 Soviet ground and air troops on Polish soil from the late 1940s until 1992.



A new (in 1990) T-72M1Z represents Polish resistance to foreign invasion.

After essentially following Soviet military doctrine for forty-five years, in 1990 Poland began formulating independent doctrine taking into account a vastly different European strategic situation. The first public declaration of a new approach came in February 1990, when Poland was still a member of the Warsaw Pact. The guidelines issued by Jaruzelski's national security agency, the National Defense Committee (which at that point still included some communists), were clearly labeled as transitional, and the statement included a one-sentence reiteration of loyalty to Warsaw Pact obligations. Nevertheless, some independent positions were taken. Poland now categorically rejected initiation of military action against another state and participation in a war unless its allies were attacked. Maintenance of Polish troops beyond national borders was described as contradictory to national interests. In case of an attack on a Warsaw Pact member, only Polish authorities would determine the appropriate response of Poland, Polish commanders would retain full control of Polish troops, and Polish forces would remain discrete units rather than being integrated with Soviet troops. As an extension of the Warsaw Pact doctrinal revision that began in 1987, the guidelines assigned the highest priority to defending against attack by air, armored, and amphibious forces.

In 1990 the Commission on National Defense of the Sejm, the lower house of Parliament, strongly criticized the initial KOK reform program as insufficient for full military reform and as retaining too much of Poland's past subservience to the Warsaw Pact. The total collapse of the pact in the following year required more complete revision of military doctrine. A new program called Armed Forces '90 represented a second, truly post-communist,

phase of military reform. It was a long-term plan of steps to be completed by the year 2000. Already in mid-1990, the military began implementing plans to apportion defensive forces more evenly between Poland's eastern and western borders.

From mid-1990 to mid-1995, the topic of appropriate doctrine for Poland received extensive treatment in general and specialized forums, but doctrinal reform was stymied by internal political conflicts. All agreed that henceforth the basic mission of the Polish defense system should be protecting the sovereignty, independence, and territorial integrity of the Polish nation. The means to that end were more problematic, however. In mid-1991 a deputy to the chief of the General Staff proposed that the new Polish Army (the word people's having been dropped from the title in 1990) be built around assault-landing brigades, helicopter regiments, armored and motorized units, and special forces such as mountain infantry, to achieve optimal flexibility and mobility in the defensive posture. Poland would also begin manufacturing sophisticated modern weapons and purchase medium-class warships. The chief obstacle to this plan, however, was a military budget that in 1991 barely sustained routine maintenance.

A comprehensive doctrinal reform first proposed in mid-1991 was never approved because of disagreement between President Lech Walesa, on one side, and Prime Minister Jan Olszewski and Minister of National Defense Jan Parys, on the other, over the question of which office should control military policy. In mid-1992, after the Olszewski government fell, a new draft doctrine was prepared by the president's National Security Bureau (*Biuro Bezpieczeństwa Narodowego*—"BBN") and officials of the ministries of foreign affairs and national defense.



Serbian guns fire on Croat positions during the Croatian war of independence.

The basic assumption of the new doctrine was that Poland could be threatened with any form of attack from outside, emphasizing possible spillover from ethnic or border conflicts in the former Yugoslavian and Soviet republics. In addition, serious consideration was given to concerns about civil unrest or strikes, a massive influx of refugees from the Balkans, and the failure of other countries to fulfill economic obligations. In early 1992, Russia provided a prime example of the third type of risk by unexpectedly demanding a revision of the terms of a crucial barter agreement to supply natural gas to Poland. Within Poland conversion from a centrally planned economy to free enterprise would cause social strains, leading to mass emigration, crime, and relaxation of social rules. The new doctrine therefore recommended

completing social reconstruction as quickly as possible to minimize disruptions that might threaten national security. Given budgetary constraints, planners estimated that national security requirements could be met with a total force of about 200,000, or 60 percent of the force level in the 1980s, together with a National Guard force of unspecified size.

In the spirit of cooperation with all neighbors, the doctrine refused membership in any military alliance directed against any neighbor. It also rejected deployment of Polish forces abroad except in accordance with international agreements; a United Nations (UN) peacekeeping mission, for example, would be permitted. Specifically mentioned were close and friendly relations with Russia, Belarus, Ukraine, and Lithuania. An important element of this general concept was close cooperation with the Conference on Security and Cooperation in Europe.

Strategy and Tactics

Until 1990 Polish strategic missions were determined by the country's assigned role in the Warsaw Pact. The overall theme was prevention of war in peacetime and defense of the Soviet Union and its allies in wartime. Through the mid-1980s, the alliance emphasized strategic offense over strategic defense, with a single strategic plan integrating the two aspects. The plan heavily emphasized overlap and cooperation of strategic missions in a combined arms format. The Soviet Union initially used the Warsaw Pact primarily to retain military and political control of its East European allies beneath a facade of collective decision making. Soviet dominance began to diminish in the 1960s, however, and by the 1980s the alliance had become a forum for debate and bargaining over issues of national independence and autonomous decision making. Until 1989, Poland's military leaders remained cautious in expressing independent views on questions of strategy.

By the mid-1990s, international events fully had fully revealed the utility of Poland's Warsaw Pact membership. The anti-West German rationale behind the alliance seemed especially relevant in view of Soviet approval of German reunification and Germany's rejection of the Oder-Neisse Line as the permanent border with Poland. In the summer of 1990, Czechoslovak and Polish proposals for substantial reform in the alliance structure brought no constructive response from the Soviet Union. Shortly thereafter, the Russian Ministry of Foreign Affairs began making public reference to Poland's withdrawal from the Warsaw Pact and the pact's impending disintegration. Meanwhile, internal strife in the Poland reinforced the need for the return to Warsaw Pact strategic (an argument that in reality had been strengthening at least since Gorbachev's reform programs began in the mid-1980s).

Beginning in 1990, Polish military strategists and tacticians shifted toward defensive techniques over offensive operations. Their theories promoted a mobile, nonlinear defense based on enhanced force maneuverability. The new strategic defense plan included creating conditions favorable to a war of maneuver, constructing tactical and permanent fortifications, protecting the military communications network in wartime, and preparing to destroy key objectives to prevent their use by the enemy. The context of this program was defensive battle against superior forces, using terrain features to channel the enemy into areas vulnerable to a Polish

counterattack. If this goal were not possible, the mission would be to extend the engagement long enough to raise the political cost to the aggressor by making the conflict a threat to general European security. Partisan resistance after defeat of Poland's conventional forces was rejected because of projected human and material losses. New strategies featured defensive combat in the forested and flooded areas that predominate in the eastern border region--a strong indication of Poland's new threat perception. Air defense, although labeled a top priority by Polish planners, remained very poorly defined and equipped in mid-1995.

Strategic writings in the early 1990s contemplated no action outside Poland. In keeping with Poland's shifting threat perceptions involving Kaliningrad and Gdansk, the military establishment agreed on a shift of force concentration to the western borders and shore of the Baltic. Military districts were redesignated accordingly in 1991. Budget constraints and the lack of military basing infrastructure limited implementation of this policy by preventing large-scale force shifts, however. In 1995 about 70 percent of Polish forces remained west of the Vistula River (compared with 75 percent in the Warsaw Pact alignment), and Polish defensive lines remained static, deep, and echeloned, in keeping with standard Soviet practice.

Military Cooperation and Exchanges



Polish UN peacekeepers in Bosnia, 1992

Poland's pattern of military cooperation changed as drastically as its political climate in 1989. Participation in Warsaw Pact joint exercises ended in 1988, and the Polish military establishment was forced to end its close working relationship with its Soviet counterparts. The April 1990 appointment of Solidarity intellectual Janusz Onyszkiewicz as deputy minister of national defense for foreign military relations signaled a new orientation in the defense establishment. Once the disintegration of the Soviet Union altered the geopolitics of all Eastern Europe, however, Poland sought new, equal military partnerships with Russia and other former Soviet republics. A comprehensive cooperation treaty completed in late 1991 replaced the Polish-Soviet friendship treaty of 1965, which had legitimized Soviet domination of Polish military policy. The

new pact, given urgency on the Polish side by the terrorist plot uncovered of August 1991, rejected all interference in Polish affairs by the then current Soviet state or by any state that might succeed it.

In the Persian Gulf War, Poland provided a hospital ship, a rescue ship, and a ground field hospital to U.N. forces. Polish troops were among U.N. peacekeeping forces in the Balkans in 1991-95. In 1992 the Polish navy participated with the Russian navy in a joint exercise in the Baltic Sea.

Before the collapse of the Warsaw Pact in 1991, security specialists from the Visegrád Triangle member nations (the CSFR, Hungary, and Poland) discussed military cooperation to supplement the economic and political programs already underway. National security cooperation within the grouping had already included decades of Warsaw Pact joint military exercises, use of standardized Soviet weapons, organization, and tactics, negotiation as a bloc for favorable arms purchase prices and joint licensing agreements for their arms industries, and collaboration in 1988-89 in demanding a restructured Warsaw Pact. Beginning in 1991, the Visegrád Triangle nations arranged group purchases of equipment from suppliers to reduce per-unit cost. The defense industries of Poland and the CSFR also began coproduction of specific armaments in 1991.

The common objective that emerged in the Visegrád talks was regional stability based on links with Eastern European security systems and a renewed commitment to defense from potential western (nee German) aggression. The Visegrád Triangle nations extended their economic rationale to strategic doctrine, seeking segregation from West European groupings by presenting a united security position to organizations such as NATO and the CSCE. According to that position, security depended on the broadest possible Eastern European integration, reinforcing formal bilateral and multilateral military alliances that excluded parts of the continent.



Polish units assigned to KFOR in Kosovo, 1995.

CHAPTER 3 DEFENSE ORGANIZATION

The overall reassessment of Poland's military position brought fundamental change in the structure of the military establishment, beginning with the separation of the military branches from the civilian administration. Ultimate command was firmly assigned to civilian officials. Such a change from the simplicity of the Jaruzelski government, where the military had occupied top government positions, caused considerable friction and confusion in the 1990s.

The Communist Tradition

Under Poland's communist regimes, the Politburo of the PZPR was ultimately responsible for major military policy decisions, with nominal responsibility lodged with the Council of Ministers. The Administration Department of the PZPR's Central Committee closely supervised military affairs, monitoring such items as promotions and budgets. The minister of national defense, who was always a general officer and usually a full member of the Politburo, was supreme commander of the army and chief of operations. Beginning in 1982, however, Jaruzelski delegated this responsibility (which he nominally retained after becoming head of state) to General Siwicki. The Polish People's Army included all branches--ground forces, navy, air force, and air defense-- but lines of command differed among the services. Commanders of the naval and air forces reported directly to the minister of national defense. The ground forces, on the other hand, reported to the minister of national defense through the General Staff. In practice, the minister of national defense often commanded all aspects of a military exercise, and the General Staff, which nominally commanded only the ground forces, made policy binding on all branches.

The armed forces were divided into the operational army and the National Territorial Defense Forces (*Obrona Terytorium Kraju* - "OTK"). The former was organized as an integral part of Warsaw Pact forces, whereas the latter was limited to service in Poland and had no role in Warsaw Pact activities. The operational army forces were administered in three military districts--Wroclaw, Bydgoszcz, and Warsaw--each of which had a two-division corps and a rapid-reaction corps.

Evolution and Restructuring

The accommodation of the Polish Army's command structure to the domestic and foreign conditions of post-Warsaw Pact Europe was a fitful and controversial process. The transfer of military policy making to civilian authority, in itself a widely accepted goal, brought intragovernmental power struggles. Together with severe budgetary limitations, those struggles caused great uncertainty in the military community about future directions.

Civilian Command Structure

In mid-1991 an Interministerial Commission for the Reorganization of National Defense submitted its structural reform recommendations to the Council of Ministers, citing the need to amend the constitution and the law on military service. The

Ministry of National Defense was to be converted into a civilian organ of state administration with a separate, subordinate armed forces section. Appointment of a civilian minister of national defense would improve the ministry's communications and joint activity with Parliament, state agencies, and the national economy, ensure depolitization of the military, and relieve the military of responsibility for budgets, administration, supply, social issues, and other matters judged more appropriate for a civilian agency. The military section would prepare concepts for national defense, forecast international situations that might bear on national security, plan long-term projects of the arms industry, and assist in export and import policy making.



Polish infantry performing field maintenance on a damaged Skorpion.

Passage of the Little Constitution in the fall of 1992 was expected to define the previously hazy lines of national security authority. However, Walesa expressed open dissatisfaction with the control allotted the presidency, heralding possible future clashes with Parliament and the Council of Ministers over individual aspects of security policy. The Little Constitution specifies that peacetime command of the Polish Army be exercised by the president of the republic and by the prime minister and the Council of Ministers (see Constitutional Revisions after April 1989; Presidency; Council of Ministers, ch. 4). All levels of central and local government are charged with managing aspects of the national defense assigned them by the constitution and by legislation. The president oversees the activities of all such agencies. The president determines the composition of military advisory bodies in peacetime and the composition of a war staff in wartime. After consultation with the prime minister, the president appoints a minister of national defense, after consultation with the minister of national defense, he appoints the chief of the General Staff. In turn, the minister is to consult with the president on appointment of commanders of military districts and the individual services.

The Sejm is responsible for assigning appropriate levels of annual funding and for passing laws regulating defense. The Sejm's Commission on National Defense was revamped and empowered to call a defense official to testify under oath on general questions of national defense policy. The wartime national defense system

gives the president and the Council of Ministers supreme decision-making power; in wartime the Sejm is to appoint the chief commander of the Polish Army, who would have strategic command of all armed forces for the duration of wartime and who would be directly responsible to the president. If the Sejm were not in session when war began, the president would appoint the commander. The Council of Ministers has specific wartime responsibility for organizing supply and other support services from the civilian sector to the armed forces, and for protecting the civilian population from the effects of war. District governors have decision-making power for all administrative and economic units within their jurisdiction.

The minister of national defense is responsible for shaping and implementing national defense policy. The minister administers the development, education, and training of the armed forces; resolves issues of international cooperation; and oversees defense tasks assigned to outside agencies. The civilian component of the Ministry of National Defense includes vice ministers for social relations and education, defense policy, and armament. The Viceministry for Social Relations and Education includes veterans' affairs, public information, physical education, and departments of education and social policy. The Viceministry for Defense Policy includes strategic planning, foreign relations, legal affairs, mobilization policy, and the National Defense Academy (*Akademia Obrony Narodowej*—"AON"). And the Viceministry for Armament includes procurement, research and development, military technical inspection, and military and transportation infrastructure. The minister of national defense also is supported by offices or departments for intelligence (the so-called Department Two), control and supervision, personnel, and finances, as well as the office of the chief military prosecutor.

Military Command Structure

In peacetime the direct commander of the armed forces is the chief of the General Staff, who also carries the title general inspector of the armed forces. The General Staff is responsible for all phases of command, including training, strategic and organizational planning, mobilization, and logistics--activities previously divided among several departments in the Ministry of National Defense. The chief of the General Staff has three deputies: the chief of the training inspectorate, the chief of armed forces strategic planning and organization, and the chief inspector of logistics. Those officers in turn head the three main support commands of the military branch. The chief commands directly the four military districts, together with unified air and air defense, navy, and higher military education commands. Directorates for personnel, medicine, education, finances, and military police are commanded by the General Staff as a whole.

Throughout the 1980s, Poland's armed forces were administered through three military districts. In 1991, in keeping with the south western shift of threat perception, plans were made to split the Warsaw Military District, which had covered all of eastern Poland, to form a fourth military district centered in Kraków. Although this step nominally gave Poland a district to stem the influx of Balkan

refugees, the actual formation of the Kraków Military District was delayed until 1994 because funding was unavailable to make the necessary shifts of personnel and equipment.

Lines of Authority



General Waldemar Skrzypczak of the "Pomeranian" Mechanized Division consults with his staff officers outside Pila in the fall of 1997.

Many proposals for restructuring the armed forces commands suffered the same fate as those for reforming military doctrine. In 1995 no clear apportionment of military and civilian policymaking powers existed in practice, and many civilian and military offices and directorates performed redundant functions. For example, the military Directorate of Logistics Planning and the civilian Department of Procurement performed similar tasks. The relative authority of officials at comparable levels of the two organizations (such as military chiefs of staff and viceministers of defense) also remained undefined.

The locus of ultimate military command remains a hot issue; Jan Parys, minister of national defense in the Olszewski government (and the first civilian to hold that position), was dismissed by President Walesa because Parys complained that his ministry was a powerless bureaucracy under Walesa's complete control. In mid-1994 Walesa ceded nominal approval of high military appointments to Janusz Onyszkiewicz, minister of national defense in the newly formed government of Hanna Suchocka. Although Walesa's move was presented as a concession to the stature of Onyszkiewicz, many observers believed that peacetime command of the Polish Army would remain an issue of contention between the presidency and the Council of Ministers.

Establishing civilian control over the Ministry of National Defense was a necessary move toward Western-style democratic rule. However, in the early 1990s high civilian officials often were named because of political influence rather than expertise, especially in the newly redesigned Department of Education. In fact, few civilians brought any military policy experience with them into Poland's post-communist governments. This was mainly because Solidarity had avoided involvement with military and internal security policy in the contentious 1980s, fearing that opposition on those fronts might be a pretext for harsher

government repression. Even after the fall of Jaruzelski, the first Solidarity government replaced communist officials in the defense and internal affairs establishments very cautiously to avoid antagonizing the PZPR in its last two government strongholds. Once the PZPR collapsed in 1990, however, the pace of reform increased.



Officers of the Giżycka Mechanized Brigade plan for a counteroffensive against German forces.

In January 1991, Walesa began forming a National Security Council (*Rada Bezpieczeństwa Narodowego*—“RBN”) that would take the place of the KOK as the chief security policy advisory body to the executive branch. The KOK had been established by Gomulka for administration of wartime efforts (it also implemented communist party decisions during the martial law period). The RBN would have the broader task of determining appropriate defense measures against military, economic, and ecological threats to national security. It would be directed by the Bureau of National Security (BBN) and headed by a representative of Walesa. It would include experts in military, legal, foreign affairs, and domestic security matters. Because of this broad mission and RBN's direct subordination to the president, Walesa's plan immediately ran afoul of the Sejm, which refused to pass legislation making the RBN an official government body. The RBN then existed in 1991 and 1992 as an unofficial adjunct to the president's office, but the Sejm had no legal obligation to follow the RBN's policy recommendations.

By mid-1992 the RBN was taking an active and controversial role in defense planning, largely because the responsibility for national security planning had not been firmly assigned to any agency. Walesa's enemies attacked the RBN because the agency's bimonthly meetings allowed interested parties to attend unofficially and, under that stipulation, some of Walesa's cronies seemed to have access to classified information. Jan Parys, an advocate of higher force strength as a prerequisite for national security, engaged in polemics with RBN officials over budget cuts and restructuring during 1994 when he was minister of national defense.

In the meantime, the KOK had continued to exist as the official maker of national defense policy. Control of national security was a key issue of Olszewski's term as prime minister; after Olszewski's ouster, the atmosphere of defense policy making calmed, and the KOK recovered some of its stature. However, it was the BBN that issued a new defense doctrine, including potential threats and recommended responses, in July 1993. The doctrine, produced by a task force representing the General Staff and the ministries of national defense, foreign affairs, and internal affairs, became official when ratified by the KOK in the fall of 1993. The Little Constitution, ratified in October 1993, officially renamed the KOK as the RBN and prescribed changes in the structure and control of the existing agency.

ARMED SERVICES

At the time of the German invasion the Polish Army consisted of the ground forces, the navy, and the air force and air defense forces. The air force and air defense forces formally merged in 1991 when full command of the air force reverted to Poland from the Warsaw Pact and the strategic requirement for air combat outside Polish territory ended. The size of the Polish Army began to decrease dramatically in 1988, but changes in force structure were more gradual in the early 1990s. Between 1988 and 1995, the total number of armed forces personnel dropped from 897,000 (406,000 active, 491,000 reserves) to 731,500 (296,500 active, 435,000 reserves). Plans called for further reduction in the late-1990s to a total active force of slightly over 200,000.

The armed forces model proposed in 1991 for the next ten years called for increased mobility of forces, principally provided by helicopters; improved equipment quality, especially in command, air defense, and radio-electronic systems; completion of force redeployment with operational and strategic supply support in place; increased staff professionalism; and a stronger position in the world market for selected military products such as helicopters, radio-electronic equipment, and tanks. The short-term model called for air traffic control and air defense system cooperation with partners in the Visegrád Triangle; reactivation of several mechanized divisions to balance reduction of the combat readiness of the two western military districts; and complete activation of the Kraków Military District, all within the next two to three years.

In 1989 some sixty-eight military units were disbanded, and another 147 units were reorganized. According to reports, this meant the retirement of 400 tanks, 700 artillery pieces, 600 armored personnel carriers, and eighty aircraft, as well as a cut of 30,000 active-duty personnel. The 1990 schedule called for elimination of fifty-seven more units and reorganization of seventy units, retiring 450 tanks, 200 artillery pieces, and 100 armored personnel carriers.

After completion of the restructuring program, planners envisioned ground forces of nine streamlined divisions, one airborne brigade, and one coastal defense brigade. The air and air defense forces

would include one fighter division, two fighter-bomber divisions, an air reconnaissance regiment, two combat helicopter regiments, and one transport helicopter regiment. Five training regiments would serve the remaining active forces. The structure of the navy would remain essentially unchanged, featuring three flotillas and one coastal defense brigade.

Military Manpower



A young Polish conscript scouts out enemy positions.

In 1992 several factors affected the supply and demand of manpower for the Polish Army. Given reduced force levels, fewer individuals were needed; however, reduced terms of active duty created faster turnover. At the same time, reliance on sophisticated electronics, especially in the air force, made recruitment, training, and retention of highly qualified individuals more important. And the availability of qualified personnel was influenced by society's general attitude toward the military and by availability of employment in the civilian economy.

The Military and Society

The declaration of martial law in 1981 and the repression in the years that followed greatly harmed the image of the military in Polish society and within the military itself. Until that time, the Polish People's Army had consciously maintained an apolitical posture that was bolstered by its abstention from action against mass demonstrations in Polish cities in 1956 and 1970. At the same time, however, PZPR membership was strongly encouraged among military personnel and was practically a prerequisite for advancement to the senior officer grades. Party membership among military officers increased from about 50 percent in the mid-1950s to about 85 percent by 1980. Almost all senior officers were party members.

In the year 1981, however, the military became identified fully with the communist state for the first time when General Wojciech Jaruzelski became party leader and president. Throughout the 1980s, the army was viewed with distrust and antagonism. With

the fall of the Jaruzelski government in early 1989, the Polish military began an active campaign to separate itself from all political parties, to work with the former opposition leaders, and to "humanize" its image. In early 1990, Jaruzelski's announcement of his resignation from the PZPR precipitated the mass return of party cards by Polish officers, and at the last PZPR congress in 1990 the military delegation sat apart. Such symbolic acts were stimulated by the political reality that the military's symbiotic relationship with the PZPR had ended and that the military had no relationship whatever with Solidarity, the now-dominant political force that had enormous public support. And public support acquired a direct strategic value for planners in the post-Warsaw Pact world. In 1992 Professor Kazimierz Nózko of the National Defense Academy stated that the new Polish defense system must be based on "the stable foundation of psychological and patriotic preparation of all society and the armed forces to repel aggression determinedly."

In 1990 officials of the ministries of national defense and internal affairs approached officials of the Roman Catholic Church with proposals to upgrade and increase chaplain positions in the military and security forces. In 1991 the Field Ordinariate was reestablished as the church's arm to minister to the armed services. A field bishop was appointed for the first time since World War II. Between 1989 and mid-1992, the number of military chaplains had risen from twenty-nine to sixty-two.

Participation of military personnel in religious services, long discouraged under the communist regimes, increased dramatically in 1990 and became an important element of the campaign by the Ministry of National Defense to refurbish the military's image. To reinforce the patriotic image of the armed forces, the military establishment revived historical traditions such as appointing officers by a sword stroke and playing the fife and drum at the changing of the guard at the Tomb of the Unknown Soldier.



Tank crews of the 78th Tank Brigade take a moment to relax following the defeat at Częstochowa in 1997.

All political organizations were banned from the military in 1989, and military personnel were forbidden from participation in

political parties or trade unions during their term of active duty. Depoliticization of the Polish military proceeded rapidly in the early 1990s, and outward manifestations of loyalty to the military in society increased accordingly. One survey showed that 80 percent of Poles had a positive view of the military as early as 1991, and a 1992 survey showed that the military had surpassed the Roman Catholic Church as the most trusted institution in Poland. Some experts believed that such results were premature and unrealistic, however, contending that the memory of the military's role in martial law would linger in Polish society, and that attitudes among career military personnel remaining from the Warsaw Pact era would lag behind organizational reform.



A Polish paratrooper armed with a silenced Skorpion Submachinegun provided by Visegrad Partner, the Czech Republic.

In 1990 the government called in army transport equipment and personnel during a rail workers' strike in Pomerania to prevent a collapse of the national transport system. Comparisons were made between that military intervention and the role of the military in suppressing the demonstrations of 1981. However, Deputy Minister of National Defense Onyszkiewicz, whose role in Solidarity gave him public credibility, cited this application of the military as an example of a justifiable, nonpolitical use of military assets to serve society in a national emergency, without the use of force toward strikers—in contrast to the repressive activities of the martial law period. In mid-1992 Walesa's power struggle with the Ministry of National Defense again aroused public fears that the military would be used to reach political goals. Again Onyszkiewicz, now acting minister of national defense, reassured

Poles that competing political factions would use instruments of civilian government to resolve their differences.

A controversial issue after 1989 was the status of communist civilian officials and military officers who had been responsible for quashing civilian uprisings and labor strikes. Many individuals who had served during that era remained in command positions in 1992. According to a 1991 survey by the antiestablishment reformist Viritim officers' group, 40 percent of officers had "conservative" views, 45 percent were "indifferent" to reform, and only 5 percent were willing to speak openly for institutional reform. A second activist group, the illegal Association of Junior Officers for Promoting Change in the Army, sought purges of officers whose military policies did not conform to their philosophy. Their attempt to undermine the authority of the Ministry of National Defense became part of the ongoing public dispute between Walesa and the ministry over control of military policy making (see Evolution and Restructuring , this ch.).

The Polish public was not reluctant to express opinions on the military. Because of public pressure, Jaruzelski himself was called to testify about the killing of striking coal miners in 1981. Czeslaw Kiszczak, who had been minister of internal affairs in 1981, was scheduled for indictment in the fall of 1992 for issuing orders to shoot strikers. Some Poles demanded the largescale trial of former communist authorities, but by mid-1992 none had gone to jail. Especially controversial was the case of Colonel Ryszard Kuklinski, a Jaruzelski aide who defected in 1981 and revealed Warsaw Pact military secrets to the United States. Some Poles demanded that Kuklinski be pardoned; others, including many military personnel, felt that because he had betrayed Poland as well as the Jaruzelski regime, Kuklinski should remain in exile or return to serve the sentence given him in absentia.

Recruitment and Service Obligations



A Polish conscript undergoing basic training

In 1949 Polish law stipulated universal, obligatory military service for males. The Military Service Law of 1967 and its amendments set the age of mandatory service at nineteen and the age for

volunteering for service at seventeen. Failure to register and failure to report after being drafted were punishable by fine or imprisonment. The basic term of service was two years, except in highly technical positions, where the term was three years. The Council of Ministers could add one year to the term in case of national need. Soldiers entered the reserves after completing active duty. For enlisted personnel, reserve status continues until age fifty. For noncommissioned officers (NCOs) and officers, reserve status continues until age sixty. With permission of the recruitment command, a conscript could perform alternative service in a civilian social service organization, a civil defense unit, or the civilian police force. The term of service, housing, and discipline of such individuals are similar to those for active-duty personnel. The rank and grade structure is similar to that of other armed forces organizations. There are some variations, however, in the number and titles of authorized enlisted, warrant officer and officer grades.

In 1960 mandatory military training programs were instituted in civilian colleges; upon completion, a student was eligible to enter reserve status as an NCO or to secure a reserve commission in a short officer training program. In 1980 social resentment of this privilege and the inadequacy of such a training program led to a nominally mandatory one-year term of active duty upon completion of university studies. In practice, however, the training and assignments of graduating college students usually were not arduous, and many evaded the obligation entirely.

The first post-communist regime immediately shortened the terms of active duty. Terms in the ground forces dropped from twenty-four months to eighteen months, and terms in the navy and air forces dropped from thirty-six months to twenty-four months. Planners projected an eventual twelve-month term for ground forces inductees. An alternative service option was continued from the policy established by the Jaruzelski regime in 1988.

In the early 1990s, an average of 250,000 individuals were examined yearly by recruiting commissions; fewer than half entered active duty. Inductions were scheduled for spring and fall of each year, but the fall 1991 and spring 1992 calls were either limited or eliminated entirely. Experts speculated that the change in schedule was caused by a combination of low budgeting and the lack of eligible individuals; at the 1992 induction rate, Poland's active-duty forces would fall below the limitations of the 1990 Conventional Forces in Europe (CFE) Treaty (see Glossary) that cut the forces of all NATO and Warsaw Pact nations (see table 22, Appendix). In mid-1992, some 220,000 billets were listed as filled, compared with the force level of 300,000 prescribed for that stage of force reduction. Of the 220,000 billets, about 100,000 were career military and more than half were in rear-echelon rather than combat units.

In the early 1990s, cities provided the majority of recruits, and students normally received deferments. In 1991 the armed forces showed about a 20 percent shortage of officers, warrant officers, and junior officers, although interest in attending military schools had increased after military reform began. In 1992 policy makers

discussed offering qualified individuals five-year contracts as a means of augmenting skilled military specialties outside CFE limitations.

In 1990 the government enacted measures to improve military housing, living conditions of dependents, pay, and leave. By 1990 specialized personnel such as jet pilots had begun leaving the service in large numbers, partly because of personnel cutbacks but also because low pay, low prestige, and outdated equipment were not commensurate with the rigorous entrance and training requirements for their specialties. Because the military doctrine of the 1990s would rely heavily on sophisticated equipment and skilled personnel, improving service conditions for such individuals was an important planning goal in the early 1990s.

Military Training and Education

Under communist leadership, Poland's programs for military training and education received generous funding and formed a large network of institutions, all of which included political indoctrination as well as technical training. The doctrinal reorientation that began in 1987 and intensified in 1989 reduced the training load and made efficient use of training institutions an economic imperative. The new emphasis on public approval of the military brought civilian and military education programs closer together. And the political officers that had preserved party loyalty and taught communist doctrine in the Polish Army since 1944 were removed in favor of establishing a general education agency.

Conscript Training



Polish recruits basic training graduation ceremony.

Prior to 1990, individual and unit training followed the Soviet model because of Poland's regular participation in joint Warsaw Pact exercises with the Soviet Union and northern-tier allies Czechoslovakia and East Germany. Most conscripts served their entire term of active duty as privates or privates first class. Outstanding individuals were identified early for specialized schooling as NCO candidates. NCOs were required to commit to four years of additional service after completing their schooling. Thirteen warrant officer candidate schools operated in 1981,

offering specialized technical programs of between one and three years that included more political indoctrination than did programs

for NCOs.

Rank Insignia							
Rank	Starszy sierżant	Sierżant	Plutonowy	Starszy kapral	Kapral	Starszy szeregowy	Szeregowy
Abbv.	st. sierż.	sierż.	plut.	st. kpr	kpr.	st. szer.	szer
English equivalent	Staff Sergeant	Sergeant	Master Corporal	Senior Corporal	Lance Corporal	Private 1st Class	Private

Enlisted and NCO Rank Insignis

The Main Political Administration (*Główna Biuro Administracji*, known in the West by its English-language acronym, “MPA”) was headed by a deputy in the Ministry of National Defense. But the MPA also exercised independent authority as a department of the PZPR Central Committee; ultimate responsibility was to the PZPR, and the head of the MPA was appointed by the PZPR Secretariat. The MPA conducted political indoctrination in the armed forces and counseled the army in personnel policy making and appointments. Political officers in Polish People's Army units supervised party organizations and communist youth groups for conscripts. The most significant youth group was the Union of Military Youth, which sought to improve both the moral and ideological outlook of service personnel, at the same time reinforcing party control of society. In the 1980s, about half of Polish conscripts were members of the union.

In 1989 the first noncommunist government pressed hard to reform or replace the MPA. In late 1989, the organization was replaced by the Main Education Board (*Główny Zarząd Wychowawczy*—“GZW”), and party posts in the military were abolished. Party influence on military training continued, however, until late 1990, when the collapse of the PZPR and of the old state security system (together with strong pressure from Parliament), made clear to the military establishment that meaningful reform was necessary to garner crucial public support. In the post-communist years, conscript training has been limited by the budget. As of mid-1992, no division-scale exercises had been held since the Warsaw Pact era. Total exercise time for trainees was significantly reduced, and items such as projectile allotments were limited. Cruises by navy personnel and training flights for pilots, both very expensive phases of training, were curtailed; in 1992 Polish pilots averaged between forty and fifty flying hours annually, compared with an average of 200 hours for NATO pilots.

Officer Education

In the communist era, officer education began with the precepts of Marxism-Leninism and their importance in defending the socialist system. The MPA directed the officers' indoctrination in these precepts. By contrast, in training both officers and enlisted personnel the post-communist military education system emphasized the individual's role in maintaining Poland's military

heritage and traditions rather than in preserving a particular ideology. The Education Officers Corps was abolished, as was the post of deputy commanding officer in military units, which had been obligatory billets for political officers. In 1990, public skepticism toward the initial reshuffling of the military education program led to a second stage of reform. The GZW was then reconstituted as the Department of Education and given a broad educational mission. These moves were seen as a clean break with political indoctrination of the military and an opportunity to improve the professional level of military personnel.



Recent group of AON Graduates.







Higher officer candidate schools had been the major source of career officers in the Polish People's Army, although a few graduates of civilian schools switched to a military career after completing their active-duty obligation. Of the fourteen higher officer candidate schools in the 1980s, only the Technical Military Academy and the Medical Military Academy received sufficient qualified applicants. In the communist era, all schools offered programs for political officers as well. Graduation from a higher officer candidate school yielded a bachelors degree and a commission as a second lieutenant.

From 1949 to 1989 all instruction at Polish military schools was heavily politicized. At the higher officer schools and military

graduate schools, mandatory courses included Marxist philosophy, political economy, and scientific socialism. The stated goal of such courses was "to instill the socialist outlook among soldiers."

Officer training reform in the early 1990s stressed defensive techniques and sought to blend military training with education to produce well-rounded officers who could be integrated more fully into Polish society. Low attendance and low budgets required

closing some specialized schools, and several other specialized schools were merged. In some cases, joint programs were established with universities.

Rank Insignia											
Rank	Marszałek Polski	General	General broni	General dywizji	General brygady	Pułkownik	Podpułkownik	Major	Kapitan	Porucznik	Podporucznik
Abbv.	marsz.	gen.	gen. broni	gen. dyw.	gen. bryg.	plk	pplk	mjr	kpt.	por.	ppor.
English equivalent	Field Marshal	General	Lieutenant General	Major General	Brigadier	Colonel	Lieutenant Colonel	Major	Captain	Lieutenant	Second Lieutenant

Officer Rank Insignia

In another effort to depoliticize Polish military training, a single senior military school, the National Defense Academy (*Akademia Obrony Narodowej*—"AON") was established in 1990. The AON merged the General Staff and military-political academies, which had been criticized as bastions of cronyism that provided nonfunctional instructor positions for senior officers. The AON's mission is to train commanders and senior staff officers as well as to prepare civilians for service in the upper echelons of the defense bureaucracy. Graduate programs have been established offering masters and doctoral degrees. The AON also develops policy recommendations for national defense, and its faculty often participates in intragovernmental working groups assembled to define future national security policy.

Poland

Reserves and Mobilization

In the communist era, reserve training programs were inadequate to maintain large numbers of personnel in serviceready condition. In fact, some reservists completed their twentyyear obligation without ever attending training. Regulations limited both total training time and total call-up time of reserve personnel to twenty-four months or less. In 1982 this system had produced 605,000 reservists whose training was labeled as adequate. In the early 1990s, reserve training remained quite spotty.

The new Polish defense system places special emphasis on the mobilization preparation of reserves because of drastic decreases in active-duty forces. In case of military threat or war, an estimated 5 to 6 percent of overall combat forces would come from reserve

units. In this context, the training of reserve personnel, especially command, staff, and specialist positions, is much more important than it was under the communist system. According to 1992 policy, which did not vary greatly from communist-era doctrine on the subject, 400,000 to 500,000 reservists would be available for call-up. Reserve units are formed according to geographical location to achieve cohesiveness. In wartime their mission is to delay an enemy force in their area long enough for the regular army to engage. One difficulty with this system is the requirement that individual reservists maintain weapons at home specifically for emergency use, a practice at variance with Polish culture and criticized as introducing firearms into civilian society. As of the outbreak of the Twilight War in 1995, the Polish Army consisted of the ground forces, the navy, and the air force and air defense forces. The air force and air defense forces formally merged in 1991 when full command of the air force reverted to Poland from the Warsaw Pact and the strategic requirement for air combat outside Polish territory ended. The size of the Polish Army began to decrease dramatically in 1988, but changes in force structure were more gradual in the early 1990s. Between 1988 and 1992, the total number of armed forces personnel dropped from 897,000 (406,000 active, 491,000 reserves) to 731,500 (296,500 active, 435,000 reserves). Plans called for further reduction in the mid-1990s to a total active force of slightly over 200,000.



Polish Reservists called up following the German invasion of 1995

ORGANIZATION

The *Wojska Lądowe* or Polish Ground Forces were administered in four military districts. The districts defend the northeast, southeast, northwest, and southwest quadrants of the country, respectively. Once forces were redeployed to balance defenses of the eastern and western borders, Poland had a truly omnidirectional ground

defense in which two districts would engage the aggressor and the other two would serve as reserves, depending on the direction of the attack. In 1995 the Pomeranian Military District (formerly the Bydgoszcz Military District) in the northwest included the 16th Mechanized Division, 2 independent brigades, an independent armored brigade and the single remaining Polish marine.

In the Silesian Military District (formerly the Wrocław Military District), two tank divisions were converted the 12th Mechanized Division and two independent brigades.

Between 1990 and 1995, the Warsaw Military District, which covered all of eastern Poland pending organization of the Kraków Military District, went from one motorized rifle division to one mechanized division, plus one engineer brigade, three ceremonial guard brigades, one independent artillery brigade, and one air cavalry combat brigade. Once completed, the Kraków district was equipped with the new 11th armored cavalry division, one air assault unit, and one mountain infantry brigade.

CHAPTER 4 THE POLISH ARMY

The chief small arm of the Polish ground forces, the Kalashnikov rifle, is rated at the top of its class. The Radom Lucznik Works, a sewing-machine plant, is the domestic manufacturer.



Mechanized infantry advance under cover of their BWP-1

With the reductions in manpower and equipment in the post cold war era, Poland could field 3,190 Main Battle Tanks in June of 1995. Poland's front line tank force consisted of locally developed PT-91 and locally produced T-72 "Wilk" (wolf) and T-72M1 series tanks. In addition two Mechanized Divisions were still equipped with Soviet-designed T-55 tanks, introduced in the 1950s; they had been substantially upgraded by the Poles.

Some 730 amphibious reconnaissance vehicles were in use in 1995. Two types, the Hungarian-designed FUG and the Soviet designed BRDM-2, were included in that inventory; Poland began using the FUG in 1966 and the BRDM-2 around 1981. In addition Poland had 1,300 fully amphibious infantry fighting vehicles. The majority of Poland's IFVs were locally produced BWP-1 and MTLB-23 types with a smattering of locally built and BMP-2 IFVs. Some 2000 SKOT wheeled armored personnel carriers, a joint Polish and Czechoslovak design of 1959, remained in use. Many of these vehicles had been refitted as specialized command and communications vehicles, although the class was considered obsolete.

In 1995 the Polish ground forces had a total of 2,316 artillery pieces. Of that number, 883 were towed, including 715 M-1938 howitzers (122mm), 166 D-20 gun-howitzers (152mm), and 2 D-1 howitzers (152 mm). Another 617 artillery pieces were self propelled, including 498 of the 2S1 model (122mm), 111 of the Dana (M-77, 152 mm), and eight of the 2S7 (203-mm) variety. The Soviet-built M-1938 howitzer had been upgraded and replaced several times in the Soviet arsenal since its introduction in 1938.

The D-20 was designed shortly after World War II, and the D-1 was first used in 1943.

The artillery arsenal in 1995 also included 262 multiple rocket launchers, of which 232 were BM-21 and thirty RM-70 (both models 122mm). The BM-21 had been in Warsaw Pact arsenals since at least 1964; the RM-70 was added in the late 1980s to replace the older BM-14. Some 554 Soviet-designed 120mm mortars were still in service in 1995.

TERRITORIAL RESERVE

In the period between the disbanding of the Warsaw Pact and the beginning of the Twilight War Poland underwent a massive demobilization with the total number of armed forces personnel dropping from 897,000 (406,000 active, 491,000 reserves) in 1989 to slightly over 200,000 at the outbreak of the War.

While the demobilization called for the liquidation of a vast amount of soviet era armaments, Poland maintained a substantial stockpile of older weapon systems for use in the event of a general mobilization. Poland (along with other former Warsaw Pact members) flooded the international arms market with locally built T-55 main battle tanks. Due to conventional arms reduction agreements Poland destroyed over 2,000 main battle tanks and sold off another 2,000. These reductions still allowed the Polish forces to retain 4,000 T-55 tanks for use in a general mobilization.



ORMO troops from Wloclawek prepare for the last German offensive, spring of 2000.

The Polish regular army had converted to a western brigade based organizational structure. In contrast the Polish reserves retained the old Soviet organizational structure based on the Division. In the event of a general mobilization each of the military districts were bolstered by reserve units on a 2 to 1 ratio. That is, for every Regular unit one (category II) and one (category III) unit would be mobilized.

The "active reserve" (formally category II units) were comprised of former conscripts with at least 24 months prior service who had been demobilized recently (within 36 months). Throughout the demobilization period these forces remained semi-active as social organizations and were tied to specific locations. All active reserve units could be fully active within 72 hours of a general mobilization and were able to respond to local emergencies within 24 hours.

ORDER OF BATTLE



Polish tankers of the 34th Armored Cavalry Brigade lie in ambush, waiting for advancing British troops on the outskirts of Słupsk.

Pomeranian Military District, HQ in Bydgoszcz

16th Mechanized Division "Pomeranian" (Elbląg)

- 9th Armored Cavalry Brigade (Braniewo)
- 15th Mechanized Brigade "Giżycka" (Giżycko)
- 20th Mechanized Brigade "Bartoszycka" (Bartoszyce)

Independent Brigades:

78th Independent Tank Brigade

Active Reserve Units:

8th Armored Division "Studenten"
3rd Mechanized Division
137th Naval Assault Brigade
138th Naval Assault Brigade

Territorial Guard Units:

13th Infantry Division
139th Naval Assault Brigade
101st Border Guards Brigade
102nd Border Guards Brigade
103rd Border Guards Brigade

Silesian Military District, HQ in Wrocław

12th Mechanized Division "Szczecin" (Szczecin)

- 2nd Legion Mechanized Brigade (Złocieniec-Budowo)

The territorial guard units (formally category III units) were made up of former conscripts with at least 12 months prior service who had been demobilized more than 36 months before the general mobilization.

Territorial guard units tended to be geographically dispersed and would require at least 1 week to enter active duty after a call up had been issued.

- 7th Coastal Defense Brigade "Pomeranian" (Słupsk)
- 12th Mechanized Brigade (Szczecin)

Independent Brigades:

1st Engineering Brigade "Brzeska" (Brzeg)

Active Reserve Units:

5th Armored Division "Saxon"
4th Mechanized Division
232nd Air Assault Brigade

Territorial Guard Units:

15th Infantry Division
105th Border Guards Brigade
106th Border Guards Brigade



One of the remaining 3 operational T-55L Tanks of the "Dresden" Armored Division following the Battle of Radom, Spring of 1999.

Warsaw Military District, HQ in Warsaw

1st Mechanized Division "Warsaw" (Legionowo)

- 1st Mechanized Brigade "Warsaw" (Wesoła)
- 3rd Legion Mechanized Brigade (Lublin)
- 21st Podhale Rifles Brigade (Rzeszów)

Independent Brigades

25th Air Cavalry Brigade (Tomaszów Mazowiecki)
2nd Engineering Brigade "Mazovian" (Kazuń)
1st Artillery Brigade "Masurian" (Węgorzewo)

Wojska Lądowe
Sourcebook

Active Reserve Units:

- 2nd Armored Division "Dresden"
- 7th Mechanized Division
- 60th Mechanized Brigade

Territorial Guard Units:

- 17th Infantry Division
- 109th Border Guards Brigade
- 110th Border Guards Brigade
- 111th Border Guards Brigade

Krakow Military District, HQ in Krakow

11th Armored Cavalry Division (Żagań)

- 10th Armored Cavalry Brigade (Świętoszów)
- 17th Mechanized Brigade "Greater Polish" (Międzyrzecz)
- 34th Armored Cavalry Brigade (Żagań)

Independent Brigades:

- 6th Air Assault Brigade (Kraków)
- 112th Mountain Guards Brigade

Active Reserve Units:

- 10th Mechanized Division "Ponzan"
- 9th Mechanized Division
- 233rd Air Assault Brigade

Territorial Guard Units:

- 104th Border Guards Brigade
- 107th Border Guards Brigade
- 108th Border Guards Brigade



A damaged T-72 of the "Ponzan" Mechanized Division advances on U.S. positions outside Kalisz, July of 2000.



The remaining elements of the 7th Mechanized Division regroup after the recapture of Gdańsk in the Winter of 1998.

OPERATIONAL ORGANIZATION

By 1995 the Polish army was a mix of Western and old style Soviet organizational structures. The regular army units were organized along a flexible western brigade system while the reserve and territorial units retained cold war era organization. The Polish army was primarily equipped with weapons of indigenous design and manufacture – the SKOT-2 and OT-62 APCs (equivalent to the Soviet BTR-70 and BTR-50 respectively), the Dana 152mm self-propelled howitzer in lieu of the SAU-152/2S3 Soviet system and the RM-70 mounting for the Soviet

M-21 multiple-launch rocket system, in addition to the products of Poland’s historically strong small arms industry. Czechoslovakia actually spent more per capita on its military than the USSR, which is reflected by the standard of equipment provided to its army. For example, the Polish Army’s Mechanized divisions were equipped with two IFV (either BWP-1 or MTLB-23) regiments and one SKOT-2 regiment – a standard of equipment achieved by only select Red Army Category I motor rifle divisions.

		Armored Btn.						Mech Btn.						Aty. Btn.				Hel. Sqdn.				
		PT-91 Twardy	T-72M1Z Wilk	T-72M1	T-72M	T-65AM "Merida"	T-55L	BWP-1M Puma	BWP-1	SKOT-2C	ML-TB	TOPAS-2	SKOT-2A	Truck	2S1 Goździk	Wz. 1977 Dana	152mm(t)	122mm(t)	Mi-24W	W-3W	Mi-2URP	Mi-8T / Mi-17
Regular Army Units	1st Mechanized Division "Warsaw"	-	2	2	-	-	-	1	2	1	2	-	-	-	3	1	-	-	-	1	-	1
	11th Armoured Cavalry Division	1	1	4	-	-	-	1	2	1	-	-	-	-	3	1	-	-	-	1	-	1
	12th Mechanized Division "Szczecin"	-	1	2	1	-	-	1	2	1	2	-	-	-	2	1	-	1	-	1	-	1
	16th Mechanized Division "Pomeranian"	-	1	1	1	1	-	1	1	2	1	-	1	-	1	1	1	1	-	1	-	1
	78th Independent Tank Brigade	-	-	1	1	1	-	-	-	1	-	-	1	-	1	-	-	-	-	-	-	-
	25th Air Cavalry Brigade	-	-	-	-	-	-	-	-	-	2	-	-	-	-	-	-	-	2	1	-	1
	6th Air Assault Brigade	-	-	-	-	-	-	1	1	-	-	-	-	-	-	-	-	-	2	1	-	1
	"Masurian" Artillery Brigade	-	-	-	-	-	-	-	-	-	-	-	-	-	-	-	3	3	-	-	-	-
	112th Mountain Guards Brigade	-	-	-	-	-	-	-	-	-	4	-	-	-	-	-	-	2	-	-	-	-
Active Reserve Units	8th Armored Division "Studenten"	-	-	1	1	4	2	-	-	1	-	-	2	-	-	-	1	2	-	-	-	-
	5th Armored Division "Saxon"	-	-	1	1	3	3	-	-	1	-	1	1	-	-	-	1	2	-	-	-	-
	2nd Armored Division "Dresden"	-	-	-	2	4	2	-	-	1	1	1	-	-	-	-	1	2	-	-	-	-
	12th Mechanized Division "Ponzan"	-	-	-	1	1	2	-	1	1	1	1	-	-	-	-	1	2	-	-	-	-
	3rd Mechanized Division	-	-	-	1	1	2	-	1	-	1	2	1	-	-	-	1	2	-	-	-	-
	4th Mechanized Division	-	-	1	-	1	2	-	1	-	1	1	2	-	-	-	1	2	-	-	-	-
	7th Mechanized Division	-	-	-	1	1	2	-	-	1	-	2	2	-	-	-	1	2	-	-	-	-
	9th Mechanized Division	-	-	-	1	1	2	-	-	1	-	2	2	-	-	-	1	2	-	-	-	-
	60th Mechanized Brigade	-	-	-	-	-	2	-	-	-	-	1	2	-	-	-	-	1	-	-	-	-
	232nd Air Assault Brigade	-	-	-	-	-	-	-	1	-	-	-	-	1	-	-	-	-	-	2	2	-
	233rd Air Assault Brigade	-	-	-	-	-	-	-	1	-	-	-	-	1	-	-	-	-	-	2	2	-
	137th Naval Assault Brigade	-	-	-	-	-	-	-	-	2	-	2	-	-	-	-	-	1	-	-	1	-
	138th Naval Assault Brigade	-	-	-	-	-	-	-	-	2	-	2	-	-	-	-	-	1	-	-	1	-
Territorial Guard Units	13th Infantry Division	-	-	-	-	-	2	-	-	1	-	1	1	3	-	-	-	2	-	-	-	-
	15th Infantry Division	-	-	-	-	-	2	-	-	1	-	1	1	3	-	-	-	2	-	-	-	-
	17th Infantry Division	-	-	-	-	-	2	-	-	1	-	1	1	3	-	-	-	2	-	-	-	-
	139th Naval Assault Brigade	-	-	-	-	-	-	-	-	2	-	2	-	-	-	-	-	1	-	-	1	-
	101st Border Guards Brigade	-	-	-	-	-	1	-	-	-	1	-	-	2	-	-	1	1	-	-	-	-
	102nd Border Guards Brigade	-	-	-	-	-	1	-	-	-	1	-	1	2	-	-	-	1	-	-	-	-
	103rd Border Guards Brigade	-	-	-	-	-	1	-	-	-	-	1	-	2	-	-	-	2	-	-	-	-
	104th Border Guards Brigade	-	-	-	-	-	1	-	-	-	1	-	-	2	-	-	1	1	-	-	-	-
	105th Border Guards Brigade	-	-	-	-	-	1	-	-	-	1	-	1	2	-	-	-	1	-	-	-	-
	106th Border Guards Brigade	-	-	-	-	-	1	-	-	-	-	1	-	2	-	-	-	2	-	-	-	-
	107th Border Guards Brigade	-	-	-	-	-	1	-	-	-	1	-	-	2	-	-	1	1	-	-	-	-
	108th Border Guards Brigade	-	-	-	-	-	1	-	-	-	1	-	1	2	-	-	-	1	-	-	-	-
	109th Border Guards Brigade	-	-	-	-	-	1	-	-	-	-	1	-	2	-	-	-	2	-	-	-	-
	110th Border Guards Brigade	-	-	-	-	-	1	-	-	-	-	-	1	2	-	-	-	2	-	-	-	-
111th Border Guards Brigade	-	-	-	-	-	1	-	-	-	-	-	1	2	-	-	-	2	-	-	-	-	
112th Border Guards Brigade	-	-	-	-	-	1	-	-	-	-	-	1	2	-	-	-	2	-	-	-	-	

Unit History and Current Status (July, 2000):

This section provides players and referees with an overview of the current position and approximate strength of the Polish Army forces as of July 1, 2000. The divisional histories give a brief description of the major units of the Polish Armed Forces. Referees are encouraged to exercise considerable freedom in manipulating this data to suit the needs of their campaign. All strengths given for manpower have been rounded to the nearest five hundred. Tank strength is for main battle tanks only, and the numbers reflect the current best estimate of operable numbers.

1ST CAVALRY DIVISION (EX-1ST "WARSAW" MECHANIZED DIVISION)

Formerly the 1st Mechanized Division "Warsaw" This unit was badly mauled in the opening German offensive, and was withdrawn from the line in late 1996 for rest and refit. During this time, its survivors were reequipped with horses instead of armored vehicles and became cavalry.

Subordination: 1st Polish Army
Current Location: Gdynia, Poland
Manpower: 2,600
Tanks: 6 T-55



A factory fresh PT-91 moves forward to join the advance on Dresden, Spring 1998.

11TH ARMORED CAVALRY DIVISION

The 11th has fought with distinction since the German invasion.

Subordination: 1st Polish Army
Current Location: Podgaje/Jastrowiel, Pila, Poland
Manpower: 3,500
Tanks: 16 T-72s



Mechanized infantry of the Ponzan Division check the hull of their BWP for battle damage.

16TH CAVALRY DIVISION "POMERANIAN" (EX-16TH "POMERANIAN" MECHANIZED DIVISION)

Formerly the 16th Mechanized Division "Pomeranian", this unit was badly damaged by the Germans in early 1997 and was reformed as a horse cavalry division in 1998.

Subordination: 1st Polish Army
Current Location: Slupsk / Ustkallebork, Poland
Manpower: 1,200 cavalry

12TH MECHANIZED DIVISION "SZCZECIN"

The division is currently stationed in Pleszew along the road to in preparation for the NATO spring offensive. Colonel Maczek's headquarters is at Pleszew with about 100 men. There is a detached combat group of the division with 250 men, a half dozen APCs, and two tanks north of the Warta River, now trying to march south to rejoin the division main body.

Subordination: 2nd Polish Army
Current Location: Pleszew, Poland
Manpower: 2,500
Tanks: 12 *Wilk*, 10 T-72s, 3 T-55



A scout team from the "Saxon" armored division relax between battles, Summer 1997.

KRAKOW GUARDS (EX-8th "STUDENTEN" ARMORED DIVISION)

The Polish 8th Armored Division no longer exists, having formed the core of the defense force of the Free City of Krakow. The former division commander, Major General Zygmunt Bohusz-Szyszko, is now the city's police prefect.

Subordination: None
Current Location: Krakow, Poland
Manpower: 2,000+8,000 militia
Tanks: 2 *Wilk*, 8 T-55

10TH "PONZAN" MECHANIZED DIVISION

The commander of the division, Colonel Julian Filipowicz, has set up an autonomous state in southern Poland which includes the territory south and west of the deserted and devastated Katowice area. He has now styled himself the "Margrave of Silesia", and plans to increase the territory he holds north toward Czestochowa.

Subordination: None
Current Location: Raciborz, Poland
Manpower: 1,500
Tanks: 6 T-55

5TH CAVALRY DIVISION (EX-5th "SAXON" ARMORED DIVISION)

This division was reformed from remnants of the 5th Armored Division "Saxon" in 1998.
Subordination: 1st Polish Army
Current Location: Chojnice/Czluchowl
Sepolno, Poland
Manpower: 1,000 cavalry



Horse Cavaliers of the 5th "SAXON" Cavalry Division patrol Chojnice, spring 1999.

2ND "DRESDEN" ARMORED DIVISION

This division was nearly destroyed in the initial German offensive of 1995 defending Ponzan. The division was withdrawn to Katowice in January of 1996 and reequipped. In 1997 the division was heavily engaged with German in the Gdansk area and was the target of a tactical nuclear strike in late 1997.

Subordination: 1st Polish Army
Current Location: Koscierzynal Gniew/
Tczew, Poland
Manpower: 1,500
Tanks: 6 T-72, 8 T-55

25



A recently refurbished T-55L of the 9th Mechanized Division enters combat near Opole in response to a Panzergrenadier raid in force.

25TH AIR CAVALRY BRIGADE

The personnel of this brigade are now serving as infantry, since their aircraft have been grounded for lack of fuel. This unit is presently in cantonment on the outskirts of Czaplinek.

Subordination: High Command Reserve
Current Location: Czaplinek / Miroslawiecl Rusinowo,
Poland
Manpower: 200
Helicopters: 2 MI-24 Hinds, 4 MI-8 Hips

78TH INDEPENDENT TANK BRIGADE

Current strength of 600 troops and two horse-drawn howitzers. The brigade was responsible for guarding the current site of the national command headquarters at Lublin, but was dispatched west to help counter the expected NATO offensive.

Subordination: 2nd Polish Army
Current Location: Lask, Zdunska Wola, Poland
Manpower: 600



A T-72 of the 7th Mechanized Division pauses for directions following the defense of Katowice, Summer 1996.

112TH MOUNTAIN GUARDS BRIGADE

This unit was heavily engaged with Austrian and German Jagger units in the area of Ostrava inside the Czech Republic. In 1997 the unit was withdrawn to Bielsko-Biala for reorganization.

Wojska Lądowe
Sourcebook

Since the defection of the 8th Armored division the unit has been effectively cut off from the Polish high command but routinely launches independent raids on Krakow and the so-called “Margrave of Silesia”.

Subordination: 2nd Polish Army
Current Location: Bielsko-Biala, Poland
Manpower: 400

CHAPTER 5 INFANTRY WEAPONS

SMALL ARMS

Radom P-64



P-64 Pistol

<i>Weapon</i>	<i>-Recoil-</i>						
	<i>ROF</i>	<i>Dam</i>	<i>Pen</i>	<i>Blk</i>	<i>SS</i>	<i>Brst</i>	<i>Rng</i>
P-64	SA	1	Nil	1	Nil	8	388

Weapon:	P-64
Ammo:	9x18mm
Weight:	0.62 kg
Magazine:	6 Box
Price:	\$144 (C/V)

This pistol was replaced by the P-83 in Polish service in the early 1980s. Externally, it resembles the Makarov; internally, it more resembles the Walther PP. The P-64 is a basic blowback pistol that can be difficult to aim due to poorly-designed sights (though the rear sight is dovetailed in and can be replaced). It has several features inherited from its Walter PP heritage, such as a slide-mounted safety/decocker and a chamber-loaded indicator. Oddly, while the P-64 has a slide catch, but the catch has no manual release – the shooter must pull back on the slide to release it. The magazines are similar in design to those of the PP (though not interchangeable), and the P-64 even has a finder rest at the bottom of the grip. The P-64 is a rather small pistol, with a short 3.3-inch barrel and only 6.1 inches in length total.

The P-64 is a Polish 9 mm semi-automatic pistol designed to use the 9x18mm Makarov cartridge. Developed in the late 1950s at the Institute for Artillery Research (Polish: Zakład Broni Strzeleckiej Centralnego Badawczego Poligonu Artyleryjskiego, which would later become the Military Institute of Armament Technology,

Polish: Wojskowy Instytut Techniczny Uzbrojenia w Zieloncu – WITU) by a team consisting of: W. Czepukajtis, R. Zimny, H. Adamczyk, M. Adamczyk, S. Kaczmarek and J. Pyzel. The pistol is also known as the CZAK (an acronym of the designer's last names with the exception of J. Pyzel, who joined the team after the name had been established).

The P-64 was drawn from a competition for a new service pistol issued in 1958. At the prototype stage two versions of the CZAK pistol were created: the Model M (Milicyjny), with a magazine capacity of 6 rounds and chambered to use the 9x17mm Short (.380 ACP) cartridge and the Model W (Wojskowy), with a longer barrel than the Model M, a 7-round magazine capacity and using the 9x18mm Makarov round). During the evaluation phase that took place in 1961, both pistols were compared and the Model M was selected over the Model W. It was then redesigned to use the Makarov round and improved with a modified slide catch (the external catch button was removed) and better ergonomics. In 1965, the P-64, produced at the Łucznik Arms Factory in Radom, entered service with the army, police and security forces under the official designation 9 mm pistolet wz. 1964 replacing the 7.62 mm TT pistol. Currently the firearm is no longer produced, but remains in the inventories of the Polish Armed Forces and police.

The P-64 is a double-action blowback-operated pistol. It has a spring extractor contained in the slide. The rotating slide catch, installed inside the pistol's frame has a protrusion that acts as a fixed empty case ejector. The pistol has a trigger mechanism with a disconnecter (that ensures semi-automatic-only fire), a double-action trigger (that allows the pistol to be cocked as a result of pulling the trigger) and a hammer striking mechanism with an exposed hammer. The slide features a loaded chamber indicator (that visually indicates the presence of a round in the chamber) and a manual safety lever that secures the weapon from being accidentally discharged with the hammer either cocked or released also enabling the weapon to be chambered with the safety engaged or toggled off. In the "safe" position, the firing pin is locked and the trigger bar is disconnected from the hammer's notch. If the hammer is cocked and the safety engaged, the safety will release the hammer.

The P-64 is fed from a single-stack box magazine with a 6-round capacity. After the last round has been fired from the magazine the magazine's follower lifts the slide catch and locks the slide open. The slide is released by pulling it to the rear. The weapon has fixed iron sights. The square notch rear sight is fixed for firing at 50 m.

The P-64 is an original design, holding a Polish patent, number 54822. The patent applies to the unique disconnecter, shaped like an elongated plate sliding vertically inside the pistol's frame, which performs the following functions: provides an internal safety, decocks the hammer when the safety is engaged, interrupts

the weapon's cycle after every shot fired and allows the weapon to be reloaded with the safety on.

In the 1970s the trigger mechanism was slightly modified and the hammer's shape was changed (larger hammer spur).

The pistol is manufactured mainly through machine cutting. It comes equipped with a spare magazine, leather holster and cleaning kit.

With the introduction of advanced and more cost-effective production techniques in the 1970s, a comprehensive redesign of the P-64 was attempted. In 1972, a prototype pistol was developed (called the P-70) with a 14-round magazine capacity and a slide made from copper-welded stamped steel. The frame was made from a lightweight alloy. In 1976 another prototype was introduced designated the P-75, with an itamide synthetic frame, and in 1978 – the P-78 was unveiled, which features a modular trigger group and a 12-round magazine. Production of the P-78 was abandoned as it lost to the P-83 Wanad pistol in a bid for a new service sidearm for the Polish Army and police.

Twilight 2000 Notes: A large number of Polish forces, particularly reserves and militia, were still equipped with this weapon during the Twilight War.

Radom P-83 Wanad



P-83 Pistol

This pistol first entered service in late 1970s, the idea being to replace the P-64 in Polish service with a weapon that is cheaper and easier to produce. It is generally similar to the P-64, but generally using pressings, stampings, and welding. The weapon is usually finished in black oxide, though some have a bright or dull chrome finish. One of the objectives was to produce a pistol equivalent to Makarov, but cheaper to produce; the real-life price is much less than a Makarov, but the P-83 also has a relatively rough appearance. The magazines are compatible with the Makarov and vice versa. The sights are fixed, but the rear sight is dovetailed into the slide. The manual safety also automatically

decocks the P-83, and unlike the P-64, the P-83 has a proper slide lock. The P-83 is often called the "Wanad" after the name of the development and trials program that produced the P-83.

The Wanad may also be fitted with a gas cartridge/blank cartridge/rubber bullet firing adapter. This device is a muzzle attachment and when equipped with it, the Wanad is known as the P-83G. An alternative attachment may be used for firing flares, though the nomenclature is the same when this device is attached to the Wanad. The pistol itself is not loaded to fire this ammunition, and the caliber of the base pistol is not important for using the devices. The muzzle attachments add 0.1 kg each to the weight of the ammunition as well as one bulk level (as the attachments are large and round.) The attachments each hold four rounds. Gas rounds may be CS (common) or a tranquilizer gas (extremely rare). When used with blank cartridges, the P-83G is suitable for use as a starter's pistol at sporting events (and used as such in Poland).

Pistol Weapon	-Recoil-						
	ROF	Dam	Pen	Blk	SS	Brst	Rng
P-83	SA	1	Nil	1	3	Nil	9
P-93	SA	1	Nil	1	3	Nil	10

Weapon:	P-83 Wanad	P-93
Ammo:	9x18mm	9x18mm
Weight:	0.73 kg	0.75 kg
Magazine:	8	8
Price:	146	150

The P-93 is an updated version of the P-83 described before. The P-93 is more conducive to two-handed shooting, with a squared-off trigger guard front (for putting the index finger of the supporting hand). The P-93 is safer to carry, with a hammer safety, and has an adjustable high-contrast rear sight and high-contrast front sight.

Twilight 2000 Notes: This weapon equipped almost 50% of pistol-armed Polish forces in the Twilight 2000 timeline.

Lucznik PM-63 Rak

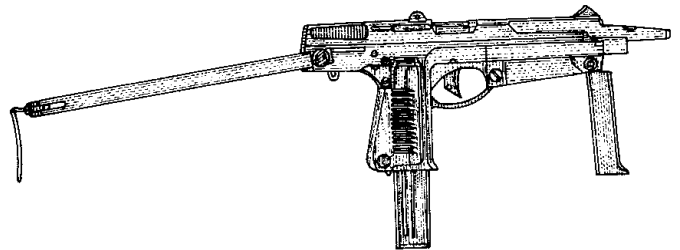

PM-63 Submachinegun

The PM-63 (also known as the Wz. 63) is basically a large automatic pistol in construction. It is meant to be a light and handy weapon for vehicle crews, rear area troops, and senior command personnel. Designed by famed Polish weapon designer Piotr

Wilniewicz, the PM-63 was one of the first of the PDW-type weapons to be mass-produced and issued on a large scale to troops. The origin of the name by which the PM-63 is commonly known in Poland, the Rak, is a bit of a mystery; some say it is an acronym for *Reczny Automat Komandosow* (Commando Hand-Held Automatic Weapon), but it is more likely that it is based on the Polish slang word *rakiem*, meaning cancer. Mr. Wilniewicz was, during most of the design process, fighting a losing struggle against cancer, and it killed him before he could finish the PM-63. (The weapon was actually finished by the rest of the design team he assigned to the PM-63.) The PM-63 was (and may still be) used by Polish troops and police forces; other users and/or former users include several Arab countries, Vietnam, Cambodia, the former East Germany, and unfortunately some terrorist groups. In addition, a version of the PM-63 was later supplied by China to other countries (see below).



The method of operation is very much like a Browning M-1903 modified for automatic fire and made much larger. The trigger is two stage; a light pull fires single shots, while a harder pull fires the weapon on automatic. The bolt has been given a little extra weight to help reduce the rate of fire to manageable proportions. Most of the cyclic rate reduction, however, is done by a weighted and spring-loaded rate reduction mechanism.

Weapon	ROF	Dam	Pen	Blk	-Recoil-		
					SS	Brs	Rng
PM-63	5	2	Nil	2/3	1	3	17
PM-70	5	2	Nil	2/3	1	3	17
PM-73	5	2	Nil	2/3	1	3	16

Weapon:	PM-63	PM-70	PM-73
Ammo:	9x18mm	9x19mm	9x17mm
Weight:	1.8 kg	1.81 kg	1.77 kg
Magazine:	15, 25, 40	15, 25, 40	15, 25, 40
Price:	304	307	291

The PM-63 has a detachable folding stock as well as a folding plastic foregrip (though early production models had no foregrip; versions without a foregrip could use the butt of the folded stock as a foregrip). Most production versions use a folding stock that has a buttplate that pivots to fold under the weapon. Aiming the weapon is virtually impossible in sustained fire, since the slide carries the rear sight, and it moves back and forth (again, like a pistol). However, the muzzle also has a simple "muzzle brake" of sorts at the end of its 5.91-inch barrel; consisting of a simple extension of

the frame, this does little more than direct the muzzle blast upward, but does a decent job of helping to reduce barrel climb (not enough, however, to count using the Twilight 2000 v2.2 rules). The device is also strong enough to allow the shooter to cock his weapon one-handed by pushing it against a hard surface and shoving the weapon forward. The PM-63 has a manual safety, but no fire selector; instead, the PM-63 uses a progressive trigger; if the trigger is pulled back to the first stop (about halfway), the shooter gets semiautomatic fire. Pulling the trigger completely back gives the shooter automatic fire. The manual safety mechanism is somewhat unusual in that it allows the slide and bolt to be locked fully back, halfway back (for stripping), or fully forward.

A special holster was also designed for use with the PM-63, though only the 15-round short magazine would fit in the holster (the 15-round magazine fits flush inside the pistol grip). 40-round magazines for the PM-63 are relatively rare, as they are rather cumbersome in such a small weapon and somewhat disliked by the troops.

There were a limited amount of PM-63s designed for use by special operations and certain espionage teams; this version had a threaded muzzle and omitted the spoon-shaped muzzle brake. This allowed that version of the PM-63 to accept a silencer. This silencer was designed for use only with subsonic ammunition, and standard Makarov ammunition will quickly destroy it.

In 1971, an abortive attempt was made to produce an export version of the PM-63 chambered for 9mm Parabellum ammunition, called the PM-70. However, the hoped-for demand for the PM-70 never materialized, and only 20 of the PM-70s were actually built. Another version, the PM-73, was chambered for .380 ACP, but also produced only in a small evaluation batch and never placed into production. I have included both below for curiosity's sake and for completeness. The PM-63 was produced in the 1980s and early 1990s in China (without a license) and called the Type 82; the Chinese don't appear to have used the Type 82, but politically-allied countries in Southeast and South Asia are known to employ them (reputedly including Iran). For game purposes, the Type 82 is identical to the PM-63.

Radom PKM-DGN (AKM)



PKM-DGN assault rifle

This is a locally-produced version of the Russian AKM and AKMS assault rifles. They are basically the same as the standard AKM and AKMS, but the Radom version can also mount the Polish Pallad grenade launcher, the Radom version can mount both Eastern-Bloc and Western optics, the handguard and stock (of the fixed-butt version) are made from plastic, and the folding-stock

version uses a different style of stock. The Radom AKM and AKMS were used by Polish forces until the Poles replaced it with the AK-74.



PKMS-DGN assault rifle

Assault Rifle Weapon	-Recoil-						
	ROF	Dam	Pen	Blk	SS	Brst	Rng
Radom AKM	5	4	2-Nil	6	4	9	46
Radom AKMS	5	4	2-Nil	5/6	4	9	46

Weapon:	Radom AKM	Radom AKMS
Ammo:	7.62x39mm	7.62x39mm
Weight:	3.165 kg	3.165 kg
Magazine:	30	30
Price:	\$807	\$827

The AKM or "automatic rifle Kalashnikov modernized") is a 7.62 mm assault rifle designed by Mikhail Kalashnikov. It is an upgraded version of the AK-47 rifle and was developed in the 1950s. Introduced into service with the Red Army in 1959, the AKM is the most ubiquitous variant of the entire AK series of firearms and it has found widespread use with most member states of the former Warsaw Pact and its many African and Asian allies. The production of Soviet rifles was carried out at both the Tula Arsenal and Izhevsk Mechanical Works. It was officially replaced in Soviet service by the AK-74 in the late 70s, but remains in use worldwide.

The AKM was accepted into service with the Polish Armed Forces in 1956 as the karabinek AKM. Produced locally at the Łucznik Arms Factory since 1966. The AKM was slated to be replaced by the kbk wz. 96 Beryl rifle, but the Beryl program was canceled with the German invasion of 1995.

Twilight 2000 Notes: There were still a fair amount of these rifles in the hands of the Polish Army at the start of the Twilight War, and most of the ones that were in storage were passed out to units raised later in the war and local militia units. Radom AKMs and AKMSs in the Twilight 2000 world do not have the ability to use Western optics.

Tantal Wz-88

The karabinek wz. 1988 Tantal ("carbine model 1988") is a 5.45mm assault rifle designed and produced in Poland in the late 1980s. At first, the design work was based directly on the AKS-74, but new firing mechanisms were eventually used, a new buttstock, four selector positions on two selector levers (the large

characteristic AK lever is used only to switch the rifle to safe), and the gas system modified to prevent the bolt cover from falling off when firing rifle grenades (a persistent problem with the AK-74 series). It may fire Polish or other Pact rifle grenades, as well as mount the GP-25 or PALLAD.



Tantal Wz-88 Assault Rifle

Design work on the new rifle officially began in 1984 at the government-owned Ośrodek Badawczo-Rozwojowy (OBR) in the city of Radom at the request of the Polish Ministry of Defense (the OBR institute had already been studying a possible 5.45mm weapon platform since late 1980). In 1985, the weapon's parameters were confirmed and factory tests were conducted by the end of that year. In 1986 the first batch of prototypes was fabricated for evaluation and qualification testing.

Assault Rifle Weapon	-Recoil-						
	ROF	Dam	Pen	Blk	SS	Brst	Rng
Tantal	3/5	3	1-Nil	4/6	2	3/4	47
Onyx	3/5	2	1-Nil	3/4	2	3/4	15

Weapon:	Tantal Wz-88	Onyx
Ammo:	5.45x39mm	5.45x39mm
Weight:	3.4 kg	2.9 kg
Magazine:	30, 40, 75	30
Price:	\$742	\$656



Onyx Wz-89 Carbine

These early prototypes, initially designated wz. 1981, were modeled on the Soviet 5.45mm AK-74 assault rifle and emphasized a high degree of parts commonality with the AKM rifle. As the weapon was intended to be able to launch rifle grenades, a newly designed, multi-functional muzzle device and a sturdier folding shoulder stock were used (the wire stock is a copy of the wire stock used on the East German MPi-KMS-72 rifle). Additionally, the wz. 81 was equipped with a mechanically-limited burst fire mode, borrowed from the AKMS wz. 1980 prototype developed in the late 1970s by OBR.

By the end of 1987 the rifle was extensively overhauled and improved (among the changes made, a series of components were introduced that were meant to be interchangeable with the AK-74, including the bolt carrier, bolt, magazines and the burst fire mode

was further refined). In January 1988, these product improved prototypes were again evaluated, and in 1989 the rifle was declared to have met its requirements, followed by an order for a pre-production batch, which was manufactured that same year. In 1990 the rifles were successfully evaluated and then transferred for final operational testing. In 1991 the rifle was introduced into service with the Polish Army as the 5,45 mm karabinek wz. 1988 (kbk wz. 88).

The weapon's design was authored by the team of engineers at OBR in Radom, under the guidance of B. Szpaderski. The rifle was produced exclusively with a folding wire stock by the Łucznik Arms Factory in Radom.

The karabinek-granatnik wz. 1974 variant with the wz. 74 Pallad under-slung grenade launcher. The Tantal is a selective fire, gas piston operated weapon that taps expanding exhaust gases off through a port in the barrel to a gas cylinder above the barrel. The barrel is locked against its longitudinal axis by a right rotating bolt. A spring extractor is contained inside the bolt head, and a fixed ejector—inside the receiver housing.

The fire control selector, with its lever located on the left side of the receiver wall, enables fully automatic fire (lever in the "C"-marked position), semi-automatic fire ("P") and 3-round burst fire mode ("S"). The selector can be operated with the safety either engaged or disabled.

The weapon is secured against misfires through a manually operated safety (whose lever, as in the AKM is located on the right side of the receiver), that disables the trigger bar and limits the movement of the bolt carrier. Sliding the safety selector to the top position (marked with a "Z" symbol) secures the weapon, lowering the lever down ("O" setting) disables the safety. The Tantal feeds from a double-column curved box magazine, made from a synthetic Bakelite material or stamped metal, with a 30-round cartridge capacity.

The cold hammer forged barrel has a chrome-plated bore with 4 right-hand grooves at a 200 mm twist rate. It is equipped with a multifunction muzzle device that can be used to launch rifle grenades.

The Tantal features a metal wire side-folding stock (folds to the right side), ended with a profiled shoulder pad. The rifle can also use a fixed wooden buttstock from the AKM rifle. Both the upper and lower handguard and pistol grip are fabricated from a synthetic material.

The rifle has mechanically adjustable iron sights that are comprised of a notch on a sliding tangent and forward post. The rear sight's drop arm has a range scale engraved with settings from 1 to 10 (corresponding to firing ranges from 100 to 1,000 m, graduated every 100 m) and a fixed setting "S" that is the equivalent to setting "4" on the range scale. Additionally, the sight assembly is fitted with a tritium gas illuminated vial that enables use in low light and near dark conditions.

Equipment supplied with the Tantal includes: three spare magazines, a 6H4 type bayonet with scabbard, bipod, four 15-round stripper clips (they enable rapid magazine charging), a stripper clip guide, cleaning kit, sling, magazine pouch and a lubricant bottle. The weapon can also be used with a blank firing adaptor after removing the muzzle device.

The wz. 88 rifle fires the intermediate 5.45x39mm ammunition with either standard, tracer or training cartridges, all produced locally by Zakłady Metalowe "Mesko" in the town of Skarżysko-Kamienna.

The Tantal was used to develop the Onyks carbine, the karabinek-granatnik wz. 1974 rifle/grenade launcher combination and a "night" variant of the wz. 1988, equipped with a receiver side-rail used to mount an NSP-3 night sight.

Twilight 2000 Notes: This weapon equipped about a quarter of Polish forces at the start of the Twilight War, and was definitely preferred over the AK-74. Tantals in the Twilight 2000 world do not have the ability to use Western optics.

SVD

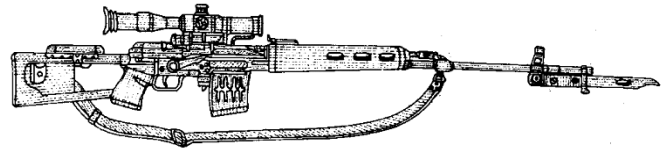

SVD Sniper Rifle

The SVD has apparently been around since the late 1950s; however, its existence was merely conjecture and rumor until the mid-1960s when examples were captured by US troops in Vietnam. The SVD is basically a highly-modified Kalashnikov, using a similar bolt system, but using a short-stroke piston system with a lightweight piston instead of the long-stroke heavy piston of the Kalashnikov series. Thus, while the Dragunov may look like it uses the Kalashnikov action from the outside, internally the Dragunov is a very different weapon

Sniper Rifle Weapon	-Recoil-						
	ROF	Dam	Pen	Blk	SS	Brst	Rng
SVD	SA	4	2-3-Nil	8	4	Nil	90
SWD-M	SA	4	2-3-Nil	8	2	Nil	107
(With Bipod)	SA	4	2-3-Nil	8	1	Nil	135

Weapon:	SVD Dragunov	SWD-M
Ammo:	7.62x54R	7.62x54R
Weight:	4.43 kg	4.37 kg
Magazine:	10	10
Price:	\$1334	\$2060

The 24.4-inch barrel is better than that used on the typical Russian rifle of the period, but is still not equal in quality to comparable Western sniper rifles of the period (such as the M-21). This barrel

is tipped with a long, slotted flash suppressor, and also has a bayonet lug (an unusual feature for a sniper rifle). The trigger group is also simply adequate for a sniper's weapon, but nothing exceptional; the fire controls include a safety sear and a disconnecter, which ensures that the trigger must be released after each shot (or trigger bar will not reconnect with the sear, and the weapon will not fire). The SVD is equipped with a sight mount attached to the left side of the receiver; this mount accepts the PSO-1 4x24 telescopic sight (standard until recently for the SVD series). The PSO-1 includes an illuminated reticle low-light conditions, and is powered by a battery which is essentially a proprietary Russian design that will fit into very few other devices. The mount will also accept the PSO-1M2, an updated PSO-1 which includes a metascope that can detect IR light sources (but is not sensitive enough for use as night vision device). Another device usable by the SVD is the NSPU-3 3.46x image intensifying scope. Iron sights are also provided. The stock has a distinctive skeletonized profile, built of weatherproofed beechwood and including a semi-pistol grip and a raised cheekpiece.



SWD-M Sniper Rifle

In the early 1980s, an upgraded version of the SVD (sometimes referred to as the SVDM) was introduced. This version is basically the same as the standard SVD, but the wooden stock has been replaced by one made of synthetic materials, and a mount is provided for a detachable bipod. In addition to the standard telescopic sights available to the SVD, the SVDM can mount a Minuta 3-9x42 scope. This scope includes an orange light filter to improve image contrast, a rangefinder and an aiming reticle, both illuminated (either simultaneously or individually).

The Polish make what is possibly the ultimate version of the SVD: the SWD-M. This version uses synthetic furniture and magazines, a light detachable bipod, and a new scope mount that in standard Polish Army issue uses a PCO LD 6x42mm telescopic sight. The stock has an adjustable cheekpiece and is adjustable for length of pull. The barrel is the same 24.4 inches long, but tipped with a compact muzzle brake and uses a heavier bull profile. The SWD-M is not issued outside certain units of the Polish Army.

Kalashnikov PK

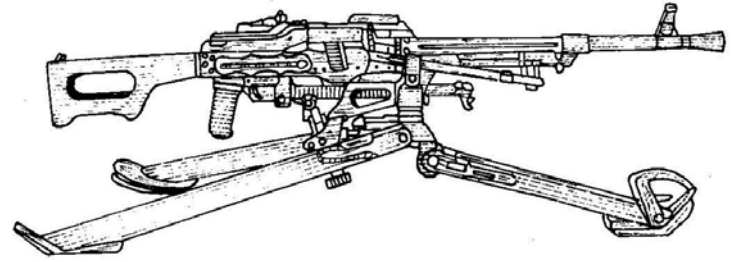

PK Machinegun

This standard GPMG in Polish service fills the same role as the M-60, MAG, MG-3, and other such weapons in other armies. The PK is sort of a mix of ideas from several previous machineguns; however, it is for the most part basically the same Kalashnikov action of the AK series of assault rifles, turned upside down and enlarged. This is added to the belt feed mechanism of a VZ-59, the trigger group of the DP, and the cartridge feed and quick change barrel of the Goryunov (though a shorter barrel). The Kalashnikov/Goryunov action makes it a very reliable and robust weapon, despite the light weight.

Introduced in 1964, the PK replaced the RP-46 and SGM in Polish service. The PK was designed to be used from a bipod or tripod (the tripod is known in *Twilight 2000* as the PLT, or Pact Light Tripod, though the weight is actually 7.47 kilograms), or pintle and vehicular mounts. The barrel is heavy, fluted for most of its length, and is 25.9 inches long with a short, conical flash hider at the end. The bipod folds forward and is attached to a reinforced section of the gas tube just behind the gas block. Feed is from the right, and the PK has been seen fed by several different lengths of non-disintegrating link belts and with several different types of ammunition boxes and containers ranging from small canvas bags holding 25 rounds to large boxes containing 250-round belts. (The box for the 250-round belt is not designed to be attached directly to the PK, but the others can be hung on a bracket on the side of the receiver.) Even larger containers are found for variants of the PK used as internal vehicular weapons. The pistol grip is of high-impact plastic, but the stock is made of wood, and its distinctive skeletonized shape is well-known to the troops of most countries.

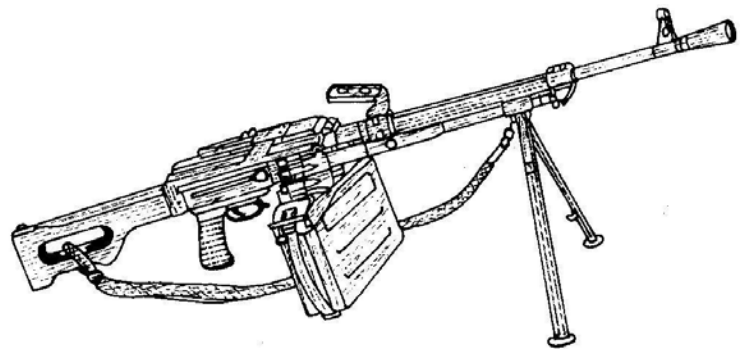

PKS Machinegun

The PKS is a variant of the PK designed for use as a support weapon and for anti-aircraft use; it is normally issued in the Russian Army at the company level. It is essentially the same weapon as

the PK, but the bipod is deleted, and the tripod used for the PKS is designed for use in both the ground role and antiaircraft role (the legs are collapsing and can be quickly raised up or collapsed again as necessary). This tripod weighs 9.3 kilograms.

The PKT is designed only for use in an internal vehicle mount, such as a coaxial weapon or the bow weapons found on some Russian-built vehicles. As is typical for such a weapon, it has no sights, stock, pistol grip, trigger mechanism, etc. – it is electrically fired by whatever trigger is used on the vehicle in question, using the vehicle's sighting devices. The PKT also uses a much longer 28.4-inch barrel.

Machinegun Weapon	-Recoil-						
	ROF	Dam	Pen	Blk	SS	Brst	Rng
PK/PKS	5	4	2-3-Nil	8	3	7	91
(With Bipod)	5	4	2-3-Nil	8	1	3	118
(With Tripod)	5	4	2-3-Nil	8	1	2	182
PKT	5	4	2-3-Nil	*	*	*	202
PKM	5	4	2-3-Nil	8	3	7	91
(With Bipod)	5	4	2-3-Nil	8	1	3	118
(With Tripod)	5	4	2-3-Nil	8	1	2	182

Weapon:	PK/PKS	PKT	PKM
Ammo:	7.62x54R	7.62x54R	7.62x54R
Weight:	8.8 kg	*	8.21 kg
Magazine:	25 Belt, 50 Belt, 100 Belt, 200 Belt, 250 Belt	*	25 Belt, 50 Belt, 100 Belt, 200 Belt, 250 Belt
Price:	\$2569	*	\$2574

The PKM is the current Polish production version of the PK (and has been since 1969); it is version of the PK which has been lightened by removing the flutes from the barrel and making it from lighter (but stronger) steel, as well as removing any excess metal possible, using almost entirely steel stampings instead of machined steel, and replacing the stock with one made from high-impact plastic (and later, polymer). A hinged support plate was also added to the stock to help support the weapon on the shooter's shoulder when it is fired from a bipod. There are several variants of the PKM which differ only in minor details; the PKMS uses a different bipod which allows the ammunition boxes (even the large one) to be secured to the right rear leg so that the gun and ammunition can be moved easier.

Degtyarev/Shpagin DShK



DShK Heavy Machinegun on tripod mount.

This design was a pre-World War 2 cooperative effort between Russian gun designers Degtyarev and Shpagin. It remained the standard Soviet and Russian heavy machinegun for almost the next 50 years before being replaced in Russian service by the NSV series. Most Russian-designed tanks in the world are still using the DShK as antiaircraft/commander's machineguns.

Operation of the DShK is by gas, with a long-stroke gas piston and capable only of automatic fire. (With a cyclic rate of fire of 550 rpm, however, squeezing off single shots is generally not difficult.) The DShK has a gas regulator, but this requires a wrench to adjust. The internal mechanism sounds complex in description, but in reality it is not that complicated. The 42.13-inch barrel is heavy, finned for cooling, and is fitted with a large muzzle brake on the end. The barrel is definitely not "quick-change," as changing a barrel requires it to be unscrewed a long way from the receiver, and before this is done, a cross-bolt must also be removed. Fire is by spade grips and a butterfly trigger. Sights consist of ladder-type rear sight and a hooded front sight post. A kit exists to affix AA sights onto the DShK. The DShK ground mount is usually a wheeled carriage, but some countries have devised a variety of tripod mounts, and a special AA mount also exists.

In the design phases, the DShK was to be magazine-fed. This was changed to belt-feeding, but not until the design process was nearly over, and belt-feed was almost an afterthought. The feed mechanism is therefore a bit complex, but does reliably feed the rounds into the gun; it essentially links what would have been the magazine well with the belt-feed gate, using a mechanism similar to the running wheels one finds in a hamster's cage. The charging handle of the DShK is really too small to be gripped in the heat of battle; most crews put extensions on the handles or at least jam a spent cartridge case into a hole that is on the end of the charging handle.

Machinegun		-Recoil-						
Weapon	ROF	Dam	Pen	Blk	SS	Brst	Rng	
DShK (PHC)	5	9	2-2-3	11	1	3	326	
APDS	5	9	1-1-1	11	1	3	326	
DShK (vehicle)	5	9	2-2-3	10	*	*	388	
APDS	5	9	1-1-1	10	*	*	388	
Weapon:	DShK							
Ammo:	12.7x108mm							
Weight:	35.5 kg							
Magazine:	50 Belt							
Price:	\$10275							

After World War 2, several design changes were made to the DShK, resulting in the DShK-38/46 (also called the DShKM). The DShK-38/46 fixed the overly-complicated and somewhat jury-rigged belt-feed mechanism, making it much simpler and giving the option of changing the feed direction of the belt. The muzzle brake was made lighter and easier to produce. Otherwise, it is identical to the DShK for game purposes.

Molot NSV Utyos



NSV Heavy Machinegun

Work on the machinegun that became the NSV began in 1969, but the first examples were not observed by the West until several years later. The NSV heavy machinegun was designed to replace the DShK in Russian and Warsaw Pact service, as well as for export sales, and it can be found almost anywhere in the world now. Until recently, the Russians no longer manufactured the NSV; however, it is still being manufactured -- by Metallist Uralsk and Kaspex in Kazakhstan, where the facilities for NSV manufacture were located after the breakup of the Soviet Union, as well as by Molot.

Machinegun		-Recoil-						
Weapon	ROF	Dam	Pen	Blk	SS	Brst	Rng	
NSV	5	9	2-3-4	10	1	3	312	
NSVT	5	9	2-3-4	10	*	*	374	
Weapon:	NSV							
Ammo:	12.7x108mm							
Weight:	24.99 kg							
Magazine:	50 Belt, 70 Belt							
Price:	\$10261							

The NSV is for the most part a conventional gas-operated heavy machinegun. The gas system uses a three-position gas regulator, which allows the gunner to compensate for fouling or dirt. The barrel, approximately 41 inches long (as with the KORD, I have not been able to find any solid figures on this) is tipped with a large conical flash hider, and though the barrel looks thin and flimsy, it is actually quite robust. Feed may be from the right or left, but the side from which the NSV feeds is set at the factory according to the needs of the buyer and cannot be changed afterwards without considerable work by an armorer. The receiver is of stamped steel with a combination of welds and rivets holding it together. For the most part, sights consist of a front hooded post and a rear folding adjustable tangent leaf sight. Ground-mounted versions and those on pintle mounts may also mount an SPP telescopic sight; this sight is a 3x/6x sight with an illuminated reticle similar to that of the PSO-1 telescopic rifle scope. The ground-mounted NSV is also able to mount a IPN52-1 night vision device. There are a several versions of the NSV, both for ground and pintle use and for internal vehicular use, most of which differ little from each other except in the direction from which they feed or the iron sights they use (or in the case of internal vehicular mountings, the use of electrical triggers instead of manual ones). Ground-mounted versions have what amounts to a rudimentary wooden stock on a strut attached to the bottom of the receiver and a conventional trigger group, while pintle-mounted models normally have spade grips and the associated trigger group.

Many NSVs on Russian and Eastern European-built or designed tanks can often be aimed and fired from either inside the turret by the commander, or directly by the commander while standing in his hatch; these use electrical firing mechanisms and the firing controls are just inside the commander's hatch. The NSV can be fired only from a tripod, pintle, or vehicular mount; while early rumors stated that the NSV could be fired from a bipod, this is in fact incorrect (though it can be fired from the prone position using the rudimentary stock). The standard ground-mount tripod weighs 16.01 kilograms, but there is also a version of this tripod which has a thick armored gun shield in front (AV3) which is meant for used in fixed fortified positions. A special antiaircraft tripod is also available, which is essentially a taller version of the standard tripod that also comes with an antiaircraft sight reticule and lead arms.

INFANTRY SUPPORT WEAPONS

RPG-76 KOMAR

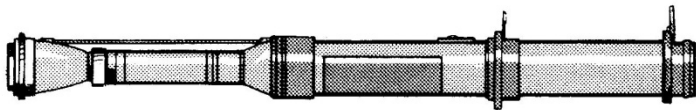

Komar single shot Anti-Tank rocket

The RPG-76 is a one-shot disposable rocket launcher, similar in design to the World War 2 German Panzerfaust. Before firing, the leaf sights are raised and a rudimentary shoulder stock is unfolded. Minimum range is 10 meters.

The Komar (eng. Mosquito) is a Polish light one-shot anti-tank grenade launcher that fires an unguided anti-tank rocket propelled grenade. The weapon was designed as a smaller and lighter alternative to the RPG-7, especially for use by airborne troops.

In 1971 in the Polish Military Institute of Defense Technology a program codenamed "Argus" was begun. The goal of the project was to develop an anti-tank grenade launcher with a single use launch tube, which could supplement the RPG-7 launcher. Two versions were considered: a recoilless rifle and a rocket propelled grenade launcher. The rocket variant was chosen due to the fact that earlier experience gained during the development of the rocket assisted PGN-60. At this stage apart from the team of Polish scientists (Z.Zborowski, K.Kowalewski, T.Witzak, Z.Kapustka, A. Perekowicz, K. Laskowski, Z.Kupidura), a team of Bulgarian scientists from the Military Institute of Research and Development in Sophia was also involved. The task of The Bulgarian scientists was to develop the rocket engine and the launcher. The presentation of the first prototype took place in 1973 on the III Central Military Invention and rationalization Exhibition, the weapon was then designated as "HEAT grenade with single use launch tube RPG-73" In 1980 a series of prototype launchers was produced. In the following years cooperation with Bulgarians has broken down, and the launcher was continued to be developed as a Polish only project.

<i>LAW</i>					
<i>Weapon</i>	<i>Round</i>	<i>Rng</i>	<i>Damage</i>	<i>Pen</i>	<i>IFR</i>
RPG-76	HEAT	65	C5 B25	53C	Nil

Rld: 0

Weapon:	RPG-76 KOMAR
Caliber:	68mm
Weight:	2.1 kg
Length:	1119mm
Price:	\$250

The weapon was adopted by the Polish Army in 1985 as "RPG-76 Komar", and with the warhead incapable of penetrating the front armor of modern western tanks it became a specialized weapon, never to be deployed by regular troops. It was produced in the Precision works in Niewiadowo, Poland.

The weapon is no longer produced, in the year 2003 it was withdrawn from front line units due to the limited ant-tank capabilities of the grenade. Polish Airborne and Special forces have replaced the RPG-76 with a small number of heavier multipurpose Carl Gustav recoilless rifles using a variety of modern ammunition types.

RPG-7 Knut

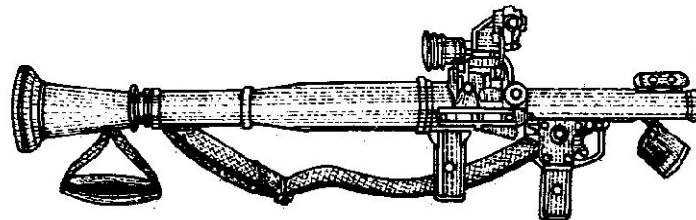

RPG-7

<i>LAW</i>					
<i>Weapon</i>	<i>Round</i>	<i>Rng</i>	<i>Damage</i>	<i>Pen</i>	<i>IFR</i>
RPG-7	M110 HEAT	105	C16 B40	140C	800
<i>Rld: 1</i>	OG-7 HE	70	C7 B25	4C	500
	OG-7M HE	90	C8 B30	4C	700
	PG-7M HEAT	85	C5 B20	51C	600
	PG-7N HEAT	100	C6 B25	72C	700
	PG-7L HEAT	85	C10 B30	103C	600
	HEAT-T	80	C11 B35	98C/122C	600

Weapon:	RPG-7
Caliber:	Several Calibers
Weight:	6.9 kg
Length:	950mm
Price:	\$850

The RPG-7 is a progressive development of the RPG-2 and a forerunner of the RPG-16. It fires a larger, but less powerful warhead. The sheer flexibility and variety of warheads have meant that the RPG-7 has been retained in service despite the introduction of several newer rocket launchers, even in Russian service. It can be found almost anywhere else and is possibly the most popular rocket launcher ever produced.

SA-14 Gremlin

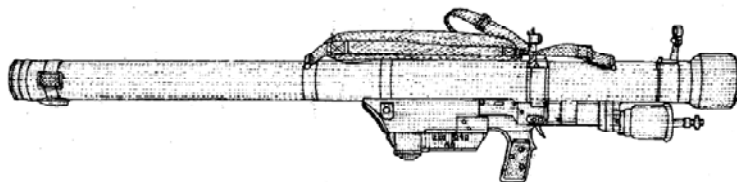

Strela-2 (SA-14) shoulder fired Surface to Air Missile

This is an improved version of the SA-7, with better guidance features. It is also less vulnerable to flares (one level harder to decoy with flares), and is less likely to take off after heat sources like the Sun.

The 9K32 “Strela-2” (Russian 9K32 “Стрела-2” — arrow, (NATO reporting name SA-7 Grail) is a man-portable, shoulder-fired, low-altitude surface-to-air missile system with a high explosive warhead and passive infrared homing guidance. Broadly comparable to the US Army FIM-43 Redeye, it was the first generation of Soviet man portable SAMs, entering service in 1968, with series production starting in 1970.

SAM						
Weapon	Round	Min	Max	Damage	Pen	Speed
SA-14A	FRAG-HE	500	4500	C6 B38	4C	2350
SA-14B	FRAG-HE	500	4500	C7 B38	4C	2350

Rld: 2

Weapon:	SA-14A	SA-14B
Weight:	16 kg	16 kg
Accuracy:	Average	Average
Guidance:	IR	IR
Sensing:	Side Aspect	Side Aspect
Price:	\$12,486	\$12,486

Described by one expert as being "...the premier Russian export line", the Strela and its variants have seen widespread use in nearly every regional conflict since 1968.

SA-16 Gimlet

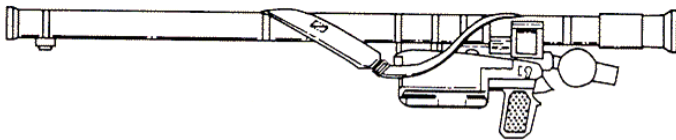

Igla (SA-18) SAM launcher

This is the standard Russian MANPADS SAM, used by Russian, Pact, Chinese, Iraqi, Iranian, and several countries' forces. It uses advanced homing capabilities. Two versions exist: one version (Igla-1E) primarily equips Russian and former Warsaw Pact troops, and has all the bells and whistles normally designed into the SA-16. The second version (Igla-1M) has no IFF interrogator (a device that tells the operator when he is aiming at a friendly aircraft) – something that be useful under some circumstances when your enemy is operating aircraft built by your own country.

SAM

Weapon	Round	Min	Max	Damage	Pen	Speed
SA-16	FRAG-HE	200	5200	C7 B38	4C	2850

Rld: 1

Weapon:	SA-16
Weight:	16.65 kg
Accuracy:	Average
Guidance:	IR
Sensing:	Side Aspect
Price:	\$12,499



9K38 Surface to Air missile

The 9K38 Iгла (Russian: Игла, needle) is a Russian/Soviet man-portable infrared homing surface-to-air missile (SAM). "9K38" is the Russian GRAU designation of the system. Its US DoD designation is SA-18 and its NATO reporting name is Grouse; a simplified, earlier version is known as the 9K310 Iгла-1, or SA-16 Gimlet.

AT-3 Sagger

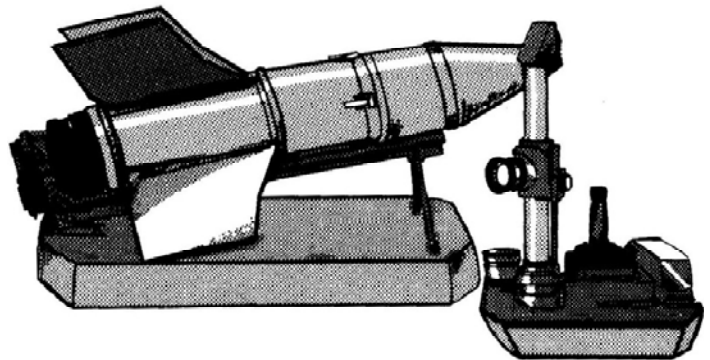

Malyutka (AT-3) Anti Tank Guided Missile system

This is the Western designation for the 9K11 Malyutka ATGM. It was first introduced in the early 1960s, and over the years, there were several new versions of the missile to cope with increasing armor threats and to increase flexibility. It is a wire guided missile that is guided from a separate guidance unit that may be physically separated from the launcher by up to 3 meters, connected by wire. The missile is very difficult to guide and requires considerable operator skill and practice, since the operator must keep both the target and missile in his sights for the entire duration of the flight. The AT-3 has long been out of service in most Warsaw Pact armies as well as Russian Category 1 and 2 units, but is still issued to lower category units and the armies of many Third World countries.

ATGM

Weapon	Round	Diff	Damage	Pen	Min	Max
AT-3 Sagger	9M14	FOR	C13 B35	70C	500	3000
	9M14M	DIF	C13 B35	70C	500	3000
	9M14P	DIF	C15 B40	89C	500	3000
	9M14MP1	DIF	C18 B40	108C	500	3000
	9M14-2	DIF	C21 B45	121C/152C	500	3000
	9M14G	DIF	C62 B40	48C	500	3000

Weapon: AT-3 Sagger
 Weights: 10.9 kg
 Missile Caliber: 125mm
 Guidance: SACLOS
 Missile Speed: 600
 Launcher Price: \$2,074
 Reload: 1

AT-3 The 9K11 Malyutka (Russian: Малютка; little or tiny baby) is the (NATO reporting name: AT-3 Sagger) is an MCLOS wire-guided anti-tank guided missile developed in the Soviet Union. It was the first man-portable anti-tank guided missile of the Soviet Union and is probably the most widely produced ATGM of all time—with Soviet production peaking at 25,000 missiles a year during the 1960s and 1970s. In addition copies of the missile have been manufactured under various names by at least five countries.

AT-4 Spigot

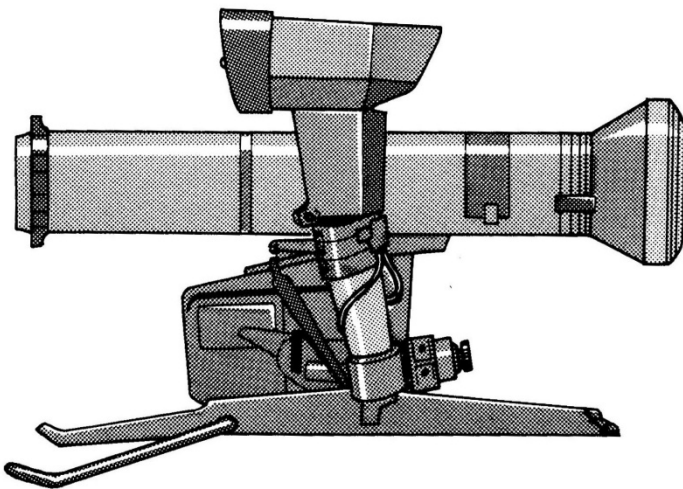

9M111 Bassoon (AT-4) Anti Tank Guided Missile system

This man-portable replaced the AT-3 Sagger in most Russian units as well as those of most First World and Second World Soviet and Russian client states. It is a large improvement in terms of guidance over the Sagger, and many comparisons have been made between the AT-4 and the Milan with regards to form factor and method of guidance. Though the AT-4's tripod/sight unit are less bulky, they are heavier than that of the Milan; the AT-4 also lacks the toughness of the Milan's electronics and is quite easy to put out of commission by a stray bump or being dropped in the wrong

way. Most AT-4's are sold with a clip-on night vision system; this is IR in the case of export systems, but usually thermal vision for Russian systems. A handicap of both of these night vision systems is that neither has the range of the 9M111-2 or 9M111M missiles that can be fired from it (2000 meters of range for the NOD, 2500 meters of range for the missiles mentioned). A later thermal imaging unit increases the observation range of the viewer to 3600 meters. Despite these shortcomings, the AT-4 has proliferated widely throughout the world. Note that the updated 9P135M-series firing units may also fire AT-5 Spandrel missiles.

AT-4 The 9M111 Fagot (Russian: 9M111 «Фарот»; English: bassoon) is a SACLOS wire-guided anti-tank missile of the Soviet Union. "9M111" is the GRAU designation of the missile. Its NATO reporting name is AT-4 Spigot.

Development

The 9M111 Fagot was developed by the Tula Machinery Design Bureau (Tula KBP). Development began in 1962 with the aim of producing the next generation of SACLOS ATGM's, for use in both the man portable role and the tank destroyer role. The 9M111 Fagot was developed alongside the AT-5 both missiles use similar technology - only differing in size.

ATGM

Weapon	Round	Diff	Damage	Pen	Min	Max
AT-4 Spigot	9M111	AVG	C14 B40	79C	70	2000
	9M111-2	AVG	C17 B40	113C	70	2500
	9M111M	AVG	C19 B45	137C	70	2500

Weapon: AT-4 Spigot
 Weights: 35.5 kg
 Missile Caliber: 120mm
 Guidance: SACLOS
 Missile Speed: 900
 Launcher Price: \$4,125
 Reload: 4

The anti-tank platoon of a Polish SKOT-2 equipped motor rifle battalion had two ATGM squads, each squad has two 9M111 Fagot teams. The team consisted of 3 men - the gunner carries the 9P135 launcher and tripod as a back pack - the other two men carry two launch tubes each. The men also carry assault rifles, but do not carry an RPG - because unlike the earlier missiles there is only a small deadzone inside which the missile cannot engage the target. In addition to the four missiles the team carries, they normally have a BTR with an additional 8 missiles.

It can also be deployed from the BWP-1, BTR-D and Skorpion.

9K113 Konkurs missile system (launcher and missile) and a 9M111M Faktoriya missile in launch tube (standing)The missile is stored and carried in a container/launch tube. It is fired from the 9P135 launcher post - a simple tripod. A 9S451 guidance box is

fitted to the tripod - with the missile sitting just above. The 9Sh119 sight is fitted to the left side (from the gunners POV). The complete launcher system weighs 22.5 kg. The gunner lays prone while firing. The system can engage moving targets providing they are travelling at less than 60 km/h. The launcher post can traverse through 360 degrees horizontally, and +/- 20 degrees in elevation. The sight has a magnification of 10x and a 5 degree field of view. Up to 3 missiles a minute can be fired from a launcher post.

The system uses a gas generator to push the missile out of the launch tube - the gas also exits from the rear of the launch tube in a similar manner to a recoilless rifle. The missile leaves the launch tube at 80 m/s. It is quickly accelerated to 186 m/s by its solid fuel motor. This initial high speed reduces the deadzone of the missile, since it can be launched directly at the target, rather than in an upward arc.

The launcher tracks the position of an incandescent infrared bulb on the back of the missile relative to the target - and transmits appropriate commands to the missile via a thin wire that trails behind the missile. The SACLOS guidance system has many benefits over MCLOS, with the accuracy of the system stated as 90% in some sources, though its performance is probably comparable to the TOW or the later SACLOS versions of the AT-3 Sagger.

AT-5 Spandrel

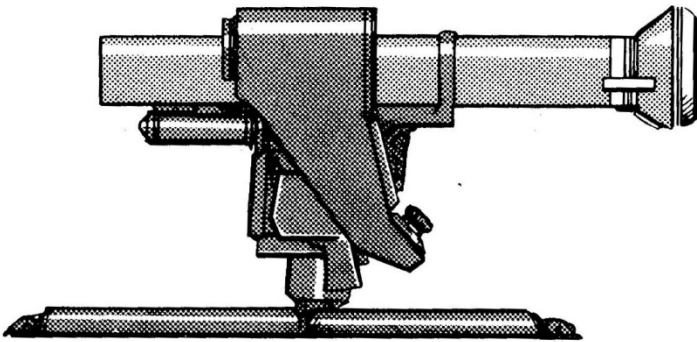

9M113 Konkurs (AT-5) Anti Tank Guided Missile system

The Spandrel was designed to replace older AT-1, 2, and 3 missiles on vehicular launchers. It was supposed to replace all vehicular AT-1, AT-2, and AT-3 missiles, there are still a lot of AT-3 and even in some smaller countries, AT-2 missiles in circulation. In some cases, the older missiles were in fact replaced by AT-4 ATGM. Also, in some cases, the deployment of the AT-5 has been leapfrogged by the newer AT-14 system. In addition, provisions were made to allow the AT-5 to be fired from newer iterations of the AT-4 Spigot launcher.

The 9M113 Konkurs (Russian: 9M113 «Конкурс»; English: contest) SACLOS wire-guided Anti-tank missile of the Soviet Union. "9M113" is the GRAU designation of the missile. Its NATO reporting name is AT-5 Spandrel.

The 9M113 Konkurs was developed by the Tula Machinery Design Bureau (Tula KBP). Development began in 1962 with the aim of producing the next generation of SACLOS ATGM's, for use

in both the man portable role and the tank destroyer role. The 9M113 Konkurs was developed alongside the AT-4; both missiles use similar technology, only differing in size.

There was some speculation that the missiles were based on the Euromissile HOT/MILAN - which employ similar concepts.[citation needed]

The missile entered service in 1974. Iran began producing a copy, the Towsan-1/M113, sometime around 2000.

ATGM

Weapon	Round	Diff	Damage	Pen	Min	Max
AT-5 Spandrel	9M113	AVG	C17 B40	129C	70	4000
	9M113M	AVG	C22 B45	119C/149C	70	4000

Weapon: AT-5 Spandrel
Weights: 35.5 kg
Missile Caliber: 135mm
Guidance: SACLOS
Missile Speed: 1000
Launcher Price: \$2,074
Reload: 6

The missile is designed to be fired from vehicles, although it can also be fired from the later models of AT-4 Spigot launchers. It is an integral part of the BMP-2, BMD-2 and BRDM-2 vehicles. The missile is stored and carried in a glass reinforced plastic container/launch tube.

The system uses a gas generator to push the missile out of the launch tube. The gas also exits from the rear of the launch tube in a similar manner to a recoilless rifle. The missile leaves the launch tube at 80 meters per second, and is quickly accelerated to 200 meters per second by its solid fuel motor. This initial high speed reduces the deadzone of the missile, since it can be launched directly at the target, rather than in an upward arc. In flight the missile spins at between five and seven revolutions per second.

The launcher tracks the position of an incandescent infrared bulb on the back of the missile relative to the target and transmits appropriate commands to the missile via a thin wire that trails behind the missile. The system has an alarm that activates when it detects jamming from a system like Shtora. The operator can then take manual control, reducing the missile to MCLOS. The SACLOS guidance system has many benefits over MCLOS. Accuracy of the system is quoted in some sources as 90%, though its performance is probably comparable to the TOW or later SACLOS versions of the Sagger.

Israel's military has unveiled that Hezbollah used 9M113 Konkurs in the 2006 Lebanon War. The Israel Defense Forces asserted that Hezbollah has employed the AT-5 Spandrel against Israeli main battle tanks in Lebanon. The Spandrel is a Russian-origin anti-tank missile sold to Iran in the 1990s and later copied by Iran. The wire-guided Spandrel measures about two meters and has a range of 3.6

kilometers. Iran was said to have begun serial production of the missile in 2000 .

9M113 Konkurs (NATO: AT-5 Spandrel, AT-5A Spandrel A)
9M113M Konkurs-M (NATO: AT-5B Spandrel B) Tandem warhead - with extended explosive probe.

AT-7 Saxhorn

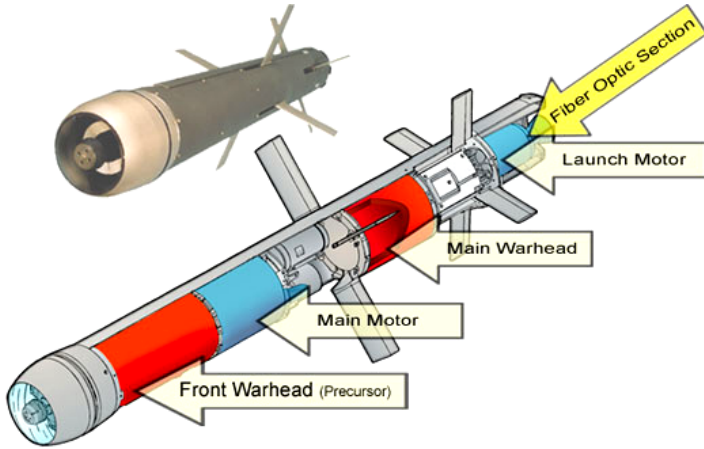

9K115 Metis (AT-7) Shoulder fired Anti Tank Guided Missile system

Originally believed to be in form and function similar to the US Dragon ATGM, that missile was subsequently revealed to in fact be a captured Dragon that the Soviets were testing with the intent to reverse-engineer. They found the Dragon's performance as lacking as US troops did, and came up with their own missile instead. The actual AT-7 is a tube-launched missile mounted on a lightweight tripod launcher. It is small and light and can even be used against slow-moving helicopters or aircraft. It is normally issued with the 1PN86V/Mulat-115 thermal imaging sight, and I have included this as part of the AT-7's cost. The AT-7 can be fired from enclosed spaces, though Russian doctrine recommends at least 2 meters of space between the back of the weapon and the wall. If fired at a target less than 500 meters away, the AT-7 may be shoulder-fired.

ATGM

<i>Weapon</i>	<i>Round</i>	<i>Diff</i>	<i>Damage</i>	<i>Pen</i>	<i>Min</i>	<i>Max</i>
AT-7 Saxhorn	9M115	AVG	C10 B30	90C	40	1000

- Weapon: AT-7 Saxhorn
- Weights: 16.5 kg
- Missile Caliber: 94mm
- Guidance: SACLOS
- Missile Speed: 800
- Launcher Price: \$3,600
- Reload: 2

The AT-7 Saxhorn is the NATO reporting name for the 9K115 Metis ("mongrel") man-portable SACLOS wire-guided anti-tank missile system of the Soviet Union. The missile was developed by the Tula KBP. It is very similar to the AT-4 Spigot in external appearance - having 3 main fins - however the missile is much lighter - primarily because of the reduced fuel load. This reduced load cuts the maximum range to 1,000 m.

During the 1980s an upgraded version of the missile was developed - the Metis-M 9M131 (sometimes labelled Metis-2). Fired from the same launcher, the new missile is much larger and heavier, with an increased range and a larger warhead. NATO labelled this missile the AT-13.

The missile was introduced into the Russian army in 1979 to supplement the AT-4 Spigot at company level. The system is lighter than the AT-4 Spigot system, due to a less complicated launcher tripod and a lighter missile.

In Russian service the AT-7 is deployed with motor rifle companies, with three launchers per company. The missile is operated by two man teams, with the gunner carrying the 9P151 launching post and one missile, his assistant carries an additional 3 missiles.

The missile can be launched from an enclosed space such as a building or cave but requires at least 6 meters behind the launcher, and a total internal volume of at least 100 m³. The missile has a short minimum range of 40 meters, and can engage targets moving at up to 60 km/h.

The missiles warhead is a single HEAT shaped charge.

CHAPTER 6 VEHICLES

UNARMORED CARGO VEHICLES



Tarpan Skorpions of the Podhale Rifles, Warsaw Spring of 1995.

Tarpan Skorpion- This is a jeep-like vehicle used in place of the UAZ-469 by Poland. The layout is conventional, and the vehicle looks similar to a Land Rover. The Skorpion comes in two sizes, a short wheelbase version (the 4012) and a long wheelbase version (the 4022). Hardtop and soft-top versions are available. There is a weapon mount either on the roof of the hardtop version or on a post behind the front seats in the soft-top version.

The prototype of the Skorpion was created in 1984 in the Farming Vehicles Works (FSR) in Poznań. Based on the earlier design of the Tarpan car, it was to replace it as the basic Polish-made pick-up truck in public service. However, it was not until 1988 that the serial production was started. The car was produced in two varieties:

- Tarpan Skorpion 4012, a typical hard top with room for up to 10 passengers
- Tarpan Skorpion 4022, a pick-up truck with room for 2 passengers

Soon after production started, the FSR started the construction of a new, slightly shorter and more narrow (2210 mm) version, which received the designation of Skorpion 4032. Although the prototype never entered serial production, it was the first car to be known solely as Skorpion, without any indication of its' relation to the earlier Tarpan.

Vehicle:	Tarpan Skorpion LWB	Tarpan Skorpion SWB
Price:	\$3800 (S/C)	\$3900 (R/S)
Range Finder:	None	None
RF modifier:	+0	+0
Armament:	None	None
Stabilization:	None	None
Ammo:	As Cargo	As Cargo
Fuel Type:	D, A	D, A
Load:	800 kg	1.18 tons
Veh Wt:	2 tons	1.68 tons
Crew:	2+8	2+4
Mnt:	2	2
Night Vision:	Headlights	Headlights

Radiological: Open Open

Movement Data

Travel Mov:	204/82	204/82
Combat Mov:	51/21	51/21
Fuel Cap:	110	110
Fuel Cons:	27	27

Combat Statistics

Config:	Std	Std
Susp:	W(2)	W(2)
ERA Facings:	None	
Hull, Front:	1 (UA)	1 (UA)
Hull, Side:	1 (UA)	1 (UA)
Hull, Rear:	1 (UA)	1 (UA)

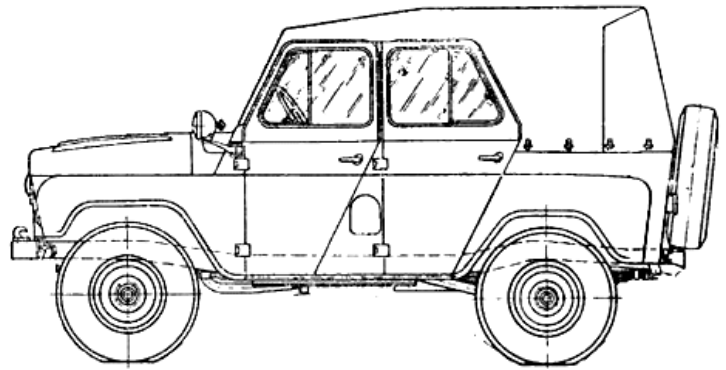

UAZ-469 Utility Vehicle

UAZ-469 This was the standard light vehicle of Russian and Polish forces, as well as almost all former or current Russian or client states. In addition, it was sold as a civilian off-road vehicle in Eastern Europe. Though in many countries it was being replaced by newer versions of the UAZ-469 or other light vehicles, the UAZ-469 was an ubiquitous sight in most of the world. It is a light Jeep-like vehicle, of conventional layout. The rear area may be open or covered by a canvas tilt; hard-bodied versions are also available. There is a weapon mount behind the front seats; however, no weapon is provided in the cost of the vehicle.

Vehicle:	UAZ-469	UAZ-469B	UAZ-3151
Price:	\$3200 (S/C)	\$3100 (S/C)	\$3250 (C/V)
Range Finder:	None	None	None
RF modifier:	+0	+0	+0
Armament:	None	None	None
Stabilization:	None	None	None
Ammo:	As Cargo	As Cargo	As Cargo
Fuel Type:	G, A	G, A	D, A
Load:	695 kg	695 kg	800 kg
Veh Wt:	1.49 tons	1.49 tons	1.38 tons
Crew:	2+5	2+5	2+5
Mnt:	1	1	1
Night Vision:	Headlights	Headlights	Headlights

Radiological:	Open	Open	Open
---------------	------	------	------

Movement Data

Travel Mov:	236/94	236/94	284/114
Combat Mov:	59/24	59/24	71/29
Fuel Cap:	78	78	78
Fuel Cons:	54	54	33

Combat Statistics

Config:	Std	Std	Std
Susp:	W(2)	W(2)	W(2)
ERA Facings:	None	None	None
Hull, Front:	1 (UA)	1 (UA)	1 (UA)
Hull, Side:	1 (UA)	1 (UA)	1 (UA)
Hull, Rear:	1 (UA)	1 (UA)	1 (UA)

The UAZ-469 was introduced in 1973, replacing the earlier GAZ-69. The UAZ-469 presented two great advantages: It was able to drive in virtually any terrain and it was very easy to fix. The UAZ-469 reached legendary status for its reliability and off-road ability. The vehicle was not available for purchase by the public, but many were sold as surplus to private owners.

The UAZ-469 (and its modifications) has earned a reputation as a very reliable and capable 4x4. It has gained huge popularity among off-road enthusiasts within Poland, as well as Europe, Asia, South America and Africa, and is preferred by many over other legendary 4x4's such as Land Rover, Jeep and Toyota.

One of the main reasons the 469 has enjoyed such popularity is its deliberately simple design, which allows for easy maintenance and repairs. Its simplicity is a deliberate design feature for 2 main reasons: the requirements of the Armed Forces, as well as the little known fact that most people in Eastern Europe prefer to fix their cars themselves as opposed to tinging them to an authorized mechanic.

UAZ-469B The UAZ-469B is a version of the standard UAZ-469. It has a lower ground clearance, which reduces the cost of the vehicle. The UAZ-469B has been sold in the West as the Tundra (not to be mistaken for the Toyota Tundra), and is used by the Warsaw Pact, Afghanistan, Cuba, Egypt, Iran, Iraq, and Syria.

UAZ-3151 The UAZ-3151 is the version of the UAZ-469 produced after 1990. It has a more powerful engine, and a diesel engine is an option. A heater is fitted, and cross-country

performance is improved with a better suspension. Poland and Czechoslovakia use this version.

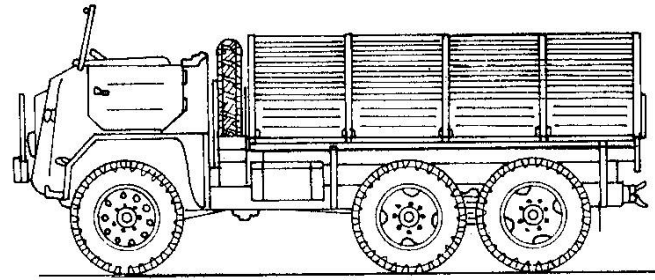

Star 66 This medium truck is a former standard medium truck used by Poland. It was also used by the Czechs, and is still used by the Vietnamese. The Star 66 was improved in the 1970s to produce the Star 660M1, and then the further improved Star 660M2 (all of which are essentially the same in game terms). Another version, which didn't get much production, was the Star 660D, with a diesel engine.

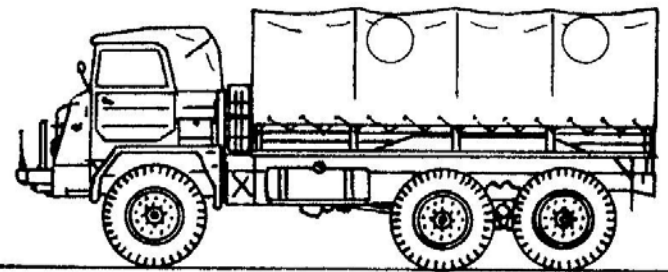

Star 266 The Star 266 is a medium 6x6 truck used by Poland. The vehicle is of cabover construction, and the cab is all steel. The rear cargo area has a removable canvas cover and a drop tailgate. The front bumper has a 6000kg capacity winch. Variants include a cargo/troop carrier and a hard-bodied workshop.

The design work on the Star 266 started in 1968. The first prototypes were ready a year later. Between 1970 and 1973 the vehicle was being prepared to enter serial production which it did in 1973.

One of the two Star 266 trucks used for the 1988 Dakar Rally in Nature and Technology Museum in Starachowice. Star 266 is widely used by civilians to transport goods and served as a basis for many civilian vehicles including fire engines, garbage trucks, sewerage service trucks and truck-mounted cranes.

Star 266 is a basic medium-capacity transport vehicle of the Polish Armed Forces and as such is used for a number of different tasks. Polish Army also uses the modernized variant of Star 266 known as Star 266M. Star 266 also served as basis for a number of different vehicles including CD-5 tank trucks which are used for transport of liquid fuel by supply platoons of tank and mechanized battalions, GD-2 smokescreen generation vehicles, truck-mounted cranes, excavators, WUS-3 and IRS special vehicles used for disinfection, deactivation and decontamination of vehicles, terrain, equipment and buildings, ADK-11 command vehicles as well as

Star-266 AP-64 and Star-266 BP-64 special transport vehicles used for transporting the elements of the PP-64 Wstęga pontoon bridge.

Vehicle:	Star 66	Star 660D	Star 266M	Star 244
Price:	\$8400 (R/S)	\$8400 (S/C)	\$8600 (S/C)	\$7800 (S/C)
Range Finder:	None	None	None	None
RF modifier:	+0	+0	+0	+0
Armament:	None	None	None	None
Stabilization:	None	None	None	None
Ammo:	As Cargo	As Cargo	As Cargo	As Cargo
Fuel Type:	G, A	D, A	D, A	D, A
Load:	2.5 tons	2.5 tons	3.5 tons	5 tons
Veh Wt:	5.7 tons	5.7 tons	7.35 tons	5.5 tons
Crew:	3+10	3+10	2+14	3+20
Mnt:	3	3	4	4
Night Vision:	Headlights	Headlights	Headlights	Headlights

Radiological:	Open	Open	Open	Open
---------------	------	------	------	------

Movement Data

Travel Mov:	134/54	132/52	138/56	142/56
Combat Mov:	34/14	33/13	35/14	36/14
Fuel Cap:	300	300	300	180
Fuel Cons:	75	36	54	55

Combat Statistics

Config:	Std	Std	Std	Std
Susp:	W(3)	W(3)	W(3)	W(2)
ERA Facings:	None	None	None	None
Hull, Front:	1 (UA)	1 (UA)	1 (UA)	1 (UA)
Hull, Side:	1 (UA)	1 (UA)	1 (UA)	1 (UA)
Hull, Rear:	1 (UA)	1 (UA)	1 (UA)	1 (UA)

Star 244 The Star 244 (4 × 4) 5,000 kg truck series was developed from the (4 × 2) Star 200 series. The proposed replacement for the Star 244 was the Star 744 (4 × 4) 3,000 kg truck. The Star 744 was subsequently replaced by the MAN-influenced Star 944 (4 × 4) 3,000/4,000 kg truck first displayed in 1999. Full details of the Star 944 can be found elsewhere in this section. Small numbers of Star 744 trucks are believed to have entered service with Polish armed forces and a small number of Star 742, a (4 × 2) variant, were supplied to the Polish Air Force as carriers of LUZES ground auxiliary power units (APU). MAN acquired the then Zakłady Starchowickie STAR SA in 2000.

The Star 244 (4 × 4) 5,000 kg truck series differs from the earlier Star 200 series mainly by the addition of front-axle drive and a reduction gear. The Type 359 6.842 litre diesel engine was retained. The forward control all-steel cab was developed in association with Chausson of France. Variants of the basic Star 244 are the Star 244RS, produced primarily for agricultural purposes; the A244 adapted to carry various forms of cross-country bodies; the P244L (wheelbase 3.9 m) for mounting fire truck bodies; and the 3W244 (wheelbase 3 m) for tipper bodies. The proposed replacement for the Star 244, the Star 744 (4 × 4) 3,000 kg truck was fitted with a shorter but essentially similar cab to the Star 266 (6 × 6) 3,500 kg truck, and powered by the same (but updated) Star T359E R6 6.842 litre six-cylinder 147 hp diesel engine.

LIGHT ARMORED VEHICLES

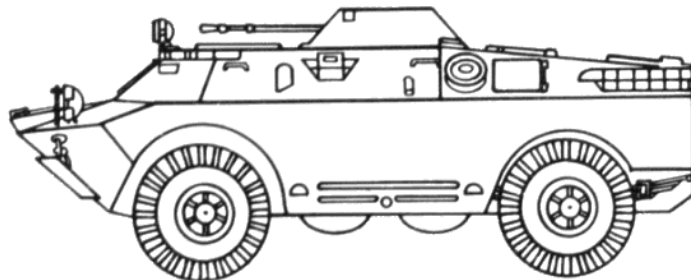

BRDM-2 reconnaissance vehicle.

BRDM-2 This replacement for the BRDM-1 was first seen in public in 1966. It features a more powerful engine for better speed, a better suspension for improved off-road maneuverability, heavier armament in a fully enclosed turret, a more powerful waterjet for higher amphibious speeds, an NBC system, and improved night vision equipment. Like the BRDM-1, the chassis is very adaptable and was produced in Poland from 1970 through the late 80's. The turret uses manual traverse and elevation and can be a bit slow in a tense situation. The BRDM-2 is or was used in its history by 45 countries and is quite a common sight throughout the world.

The BRDM-2 differs from the original BRDM in that the powerplant has improved and moved to the rear of the vehicle, and that a small 14.5mm machinegun-armed turret has been fitted. This turret is identical to that found on the BTR-60PB armored personnel carrier. The original BRDM (BTR-40P) first appeared in 1959. The BRDM-2 also is known as BTR-40P-2 or BTR-40PB (hence also BTR-40P-2rkh or BTR-40PB-rkh, etc.). It was first seen in 1966 and by the mid-1980s was rapidly replacing the BRDM in the Soviet and Warsaw Pact armies. Care must be taken to distinguish the BRDM-2 from the Hungarian FUG (OT-65) and FUG-70 amphibious scout cars which also have rear engines but have twin waterjets.

The BRDM-2 series, with maximum armor of 14 mm, can be penetrated by artillery fragments and .50 caliber machine gun fire. Its tires are not protected by armor and are particularly vulnerable to puncture from fire of all kinds.

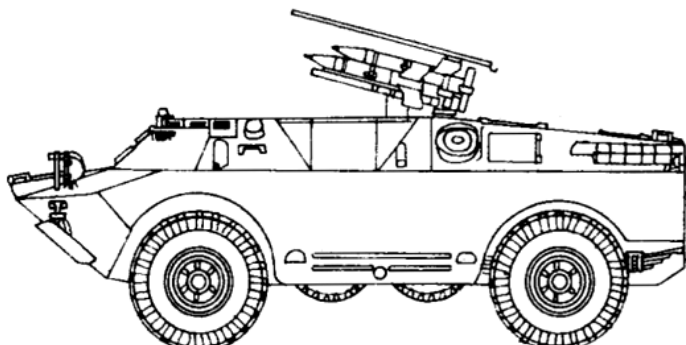

BRDM-2 Anti Armor Vehicle with AT-3 ATGM

Like the earlier BRDM, the BRDM-2 is a fully armored, four-wheel drive, amphibious reconnaissance vehicle with two pairs of

belly wheels and a centralized tire pressure regulation system for increased cross-country capability and a single water jet for propulsion through water. Externally, it differs from the BRDM due to a larger, box-like hull. It retains the boat-like bow of the BRDM, but the crew compartment has been moved farther forward and the engine has been moved to the rear. In the basic model, a small conical turret is mounted on the hull in a central position above the belly wheels. There are two front cupolas, and vision blocks are located centrally on both sides. The engine is larger than in the BRDM (140hp V-8 as opposed to 90hp 6-cylinder). The BRDM-2 is fitted with an IR spotlight and IR driving lights as well as an NBC filter system.

Like the BRDM, the BRDM-2 exists in several versions. The versions employed by the Polish Army include:

BRDM-2- The BRDM-2 reconnaissance vehicle is distinguished by its turret, which is the same as that mounted on the BTR-60PB. The conical turret, which mounts two machine guns (1 4.5-mm and 7.62-mm), is unusual in that it has no top hatch opening. This model carries a crew of four (commander, gunner, driver, and co-driver).

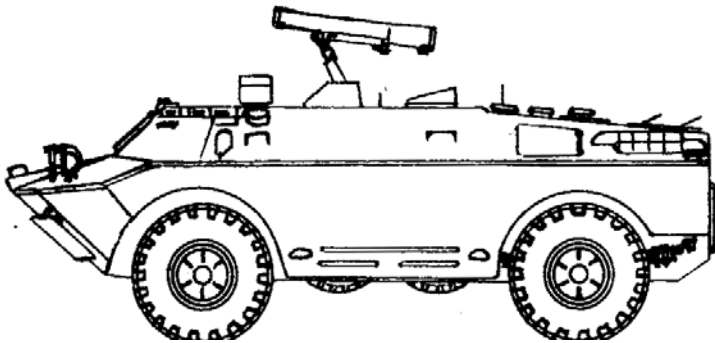

BRDM-2 Anti Armor Vehicle with AT-5 ATGM

BRDM-2 ATGM Vehicle- This vehicle is a tank destroyer version of the BRDM-2 scout car, along the same lines as the BRDM-1 ATGM Vehicle. They were first seen in public used by Egyptian and Syrian forces against the Israelis in the 1973 Yom Kippur war, carrying AT-2 or AT-3 missiles, and have been steadily upgraded since then. The launcher can be raised for firing or lowered under armor protection if necessary, and the gunner stays under armor protection.

The ATGM launcher vehicle (BRDM-2) is used for the AT-2/SWATTER, AT-3/SAGGER and AT-5/SPANDREL. The ATGM launcher replaces the turret. This model is found in regimental and divisional antitank units of motorized rifle divisions and in the antitank regiment or brigade in the artillery division of a front.

BRDM-2-RKhb -The BRDM-2-RKhb is a BRDM-2 fitted out as an NBC reconnaissance vehicle. In this role, there are two dispensers at the back of the vehicle for marking pennants. The vehicle has an optical chemical sniffer, a Geiger counter, a computerized land navigation system, and extra radios.

Vehicle:	BRDM-2	BRDM-2-RKhb	BRDM-2 ATGM
Price:	\$45000 (R / C)	\$45000 (- / S)	\$45000 (R / S)
Range Finder:	Optical	Optical	Optical
RF modifier:	+1	+2	+2
Armament:	KPV, PKT	2xPKT	5xAT-3/AT-5 Launchers
Stabilization:	Basic	Basic	Basic
Ammo:	500x14.5, 2000x7.62	2000x7.62	10xATGM
Fuel Type:	G, AvG, A	G, AvG, A	G, AvG, A
Load:	600 kg	600 kg	600 kg
Veh Wt:	7 tons	7 tons	7 tons
Crew:	2+2	4	3
Mnt:	2	4	4
Night Vision:	Passive IR	Image Int.	Passive IR
Radiological:	Shielded	Shielded	Shielded

Movement Data

Travel Mov:	150/60	150/60	173/104
Combat Mov:	38/15/4	38/15/4	29/19/3
Fuel Cap:	290	290	290
Fuel Cons:	81	81	81

Combat Statistics

Config:	CiH	CiH	CiH
Susp:	W(4)	W(4)	W(4)
ERA Facings:	None	None	None
Hull, Front:	6	6	6
Hull, Side:	3	3	3
Hull, Rear:	2	2	2
Turret, Front:	5	5	1
Turret, Side:	4	4	1
Turret, Rear:	3	3	1

Machineguns

Weapon	-Recoil-							
	ROF	Dam	Pen	Blk	Mag	SS	Brst	Rng
KPV	5	11	2-2-3	13	105B	*	*	475
PKT	5	4	2-3-Nil	8	50B	*	*	202

ATGM

Weapon	Round	Diff	Damage	Pen	Min	Max
AT-3 (9M14MP1)	HEAT	DIF	C18 B40	108C	500	3000
<i>Rld: 1</i>						
AT-5 (9M113)	HEAT	AVG	C17 B40	129C	70	4000
<i>Rld: 6</i>						

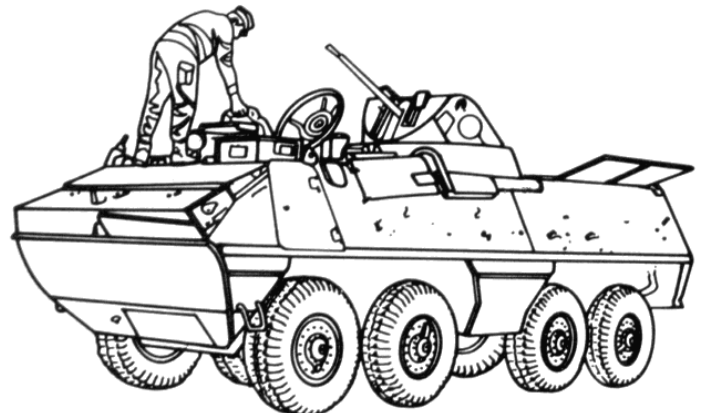

SKOT-2A Wheeled Armored Personnel Carrier

SKOT (OT-64) The OT-64 (known as the SKOT to the Poles) is a joint product of Poland and Czechoslovakia used by those countries in place of the BTR-60 and BTR-70. There are several variants available, but the main version is a basic wheeled APC with a turret in the center of the hull mounting a KPV and a PKT machinegun. This turret is the same one as mounted on the BRDM-2 and BTR-70. The next most common variant is the OT-64C(1)/SKOT-2AP; this has a new turret of a different shape than the BTR-70 and BRDM-2 turrets, and the weapons have a much higher elevation (capable of firing almost straight up). After that, there is another variant of the OT-64C(2)/SKOT-2AP; this version has a launcher for an AT-3 Sagger ATGM on either side of the turret or a double launcher to the left side and to the rear of the turret. There are at least 10 other variants for differing roles, from recovery vehicles to command post carriers. Besides Czechoslovakia and Poland, the OT-64 is used by 11 other nations, including Cambodia, India, Iraq, Syria, and several African countries.

Jointly developed and used by Czechoslovakia and Poland in place of the similar Soviet BTR-60 (8 x 8) APC, the OT-64 (SKOT) is the official designation of this armored personnel carrier with the designation "OT-64" often being used in the West.

The OT-64 wheeled amphibious personnel carrier is a combat and transport vehicle used with mechanised, communications and other specialised units. The OT-64 development was motivated by the need to replace the obsolete OT-810 APC by a newly designed armoured vehicle. The first prototype called SKOT (for "medium wheeled armoured carrier") was designed in 1959, in 1961 the first test series was produced and a contract closed between the Czech Republic and Poland on joint production. The OT-64 was introduced into both countries' armed forces in 1964.

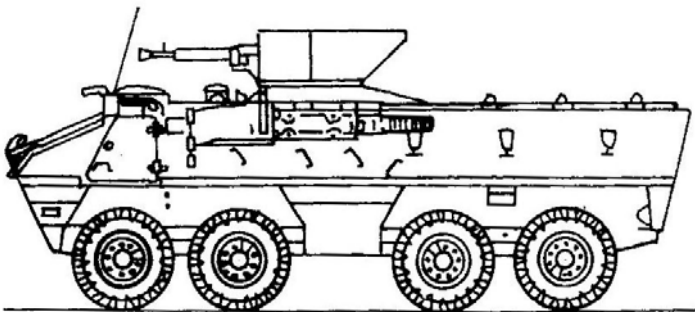

SKOT-2 Armored Personnel Carrier

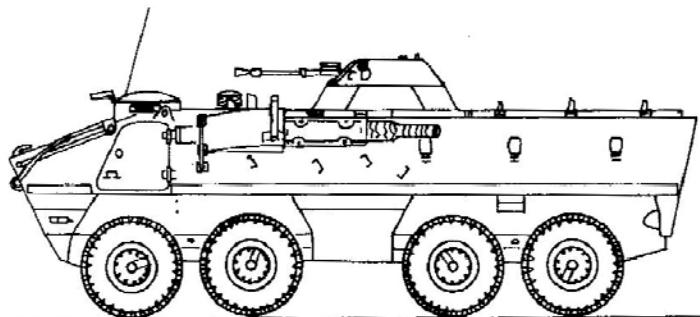

SKOT-2A Armored Personnel Carrier

SKOT-2 (OT-64B)- This model has been used only by Poland and has a pintle-mounted 7.62-mm or 12.7-mm machine gun. The gun has a shield that gives front and side protection to the gunner, but has an open top and open rear. The OT-64B has three hatches over the troop compartment: one opens forward and the other two open to each side.

Vehicle:	SKOT-2	SKOT-2A	SKOT-2AP
Price:	\$39000 (R/S)	\$55000 (S/C)	\$99500 (R/S)
Range Finder:	None	None	None
RF modifier:	None	None	None
Armament:	KPV, PKT	KPV, PKT	KPV, PKT, 2xAT-3 Launchers
Stabilization:	None	None	None
Ammo:	1250x7.62	500x14.5, 2000x7.62	500x14.5, 2000x7.62, 4xAT-3
Fuel Type:	D, A	D, A	D, A
Load:	1.7 tons	1.7 tons	1.6 tons
Veh Wt:	14.3 tons	14.3 tons	14.36 tons
Crew:	3+10	3+10	3+10
Mnt:	4	4	4
Night Vision:	Passive IR	Passive IR	Passive IR
Radiological:	Enclosed	Enclosed	Enclosed

Movement Data

	SKOT-2	SKOT-2A	SKOT-2AP
Travel Mov:	116/70	120/72	120/72
Combat Mov:	30/18/3	30/18/3	30/18/3
Fuel Cap:	330	330	330
Fuel Cons:	66	66	66

Combat Statistics

	SKOT-2	SKOT-2A	SKOT-2AP
Config:	CiH	CiH	CiH
Susp:	W(4)	W(4)	W(4)
ERA Facings:	None	None	None
Hull, Front:	6	6	6
Hull, Side:	4	4	4
Hull, Rear:	3	3	3
Turret, Front:	4	4	4
Turret, Side:	4	4	4
Turret, Rear:	4	4	4

Machineguns

Weapon	-Recoil-							
	ROF	Dam	Pen	Blk	Mag	SS	Brst	Rng
KPV	5	11	2-2-3	13	105B	*	*	475
PKT	5	4	2-3-Nil	8	50B	*	*	202

ATGM

Weapon	Round	Diff	Damage	Pen	Min	Max
AT-3 (9M14MP1)	HEAT	DIF	C18 B40	108C	500	3000

Rld: 1

SKOT-2A (OT-64C(1))- The OT-64C(1) has two layers of armament: main and secondary. Some models have been observed with a single Sagger ATGW mounted on each side of the turret with lateral armor protection. OT-64C(1) main armament is a 14.5-mm heavy machine gun mounted in the forward part of the vehicle. The practical rate of fire for this gun is 150 rds/min with a basic load of 500 rounds. OT-64C(1) secondary armament is a 7.62-mm gun mounted coaxially to the right of the main armament with the telescopic sight to the left. A practical rate of fire for this weapon is 250 rds/min with a basic load of 2,000 rounds.

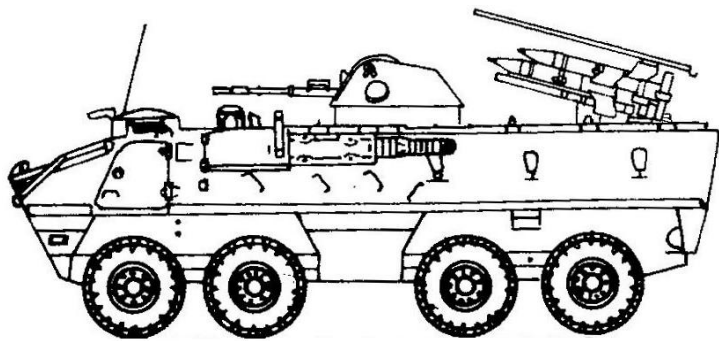

SKOT-2AP Wheeled Infantry Fighting Vehicle

SKOT-2AP (OT-64C(2))- This version is used only by Poland and is similar to the OT-64C(1) except that it has a new turret with a curved top. It is armed with a 14.5-mm KPVT machine gun with a 7.62-mm PKT machine gun mounted to the right of the main armament and the sight to the left. The weapons have an increased elevation capability, which allows them to be used against aircraft. Some vehicles have been observed with a single Sagger ATGW mounted on each side of the turret. The turret on this model is also installed on the OT-62C tracked APC.

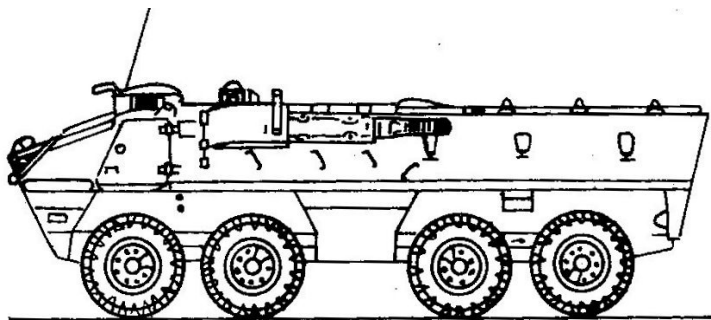

SKOT-WPT Recovery Vehicle

SKOT-WPT. A recovery vehicle based on the OT-64 is known to be in service with Poland. This is armed with a 7.62-mm PKT machine gun and is provided with a light crane for changing components in the field.

BTR-60- The BTR-60 armored personnel carrier, the first in the line of Russian 8-wheeled APC's, was developed in the late 1950s to replace the BTR-152 (6x6) APC and was first seen in public in 1961. It was continuously improved throughout the 1960s culminating in the production of the BTR-60PB, and was subsequently replaced in production by the similar BTR-70 (8x8). Numerically, the BTR-60 was the most important vehicle in the Soviet Army. It was issued in quantity to the Polish, East German, Bulgarian and Romanian Armies. It has also been exported to Yugoslavia. Significantly, it was the standard armored personnel carrier of the Soviet Naval Infantry.

The BTR-60 was developed in the late 1950s to replace the BTR-152 series. By 2000, they were mainly found in the armies of Third World nations and local police/milita units, having been replaced in the Polish army by newer versions of wheeled APCs in the OT-64 series. Early versions had an open-topped troop compartment and a pintle-mounted machinegun; a little later, the troop

compartment was enclosed and a commander's hatch with a pintle-mounted weapon was introduced, and then the primary version found by 2000 was introduced (the BTR-60PB), which has the now-familiar closed top and turret with a KPVT/PKT combination. The turret is almost identical to that on the BRDM-2 (except for the level of armor protection).

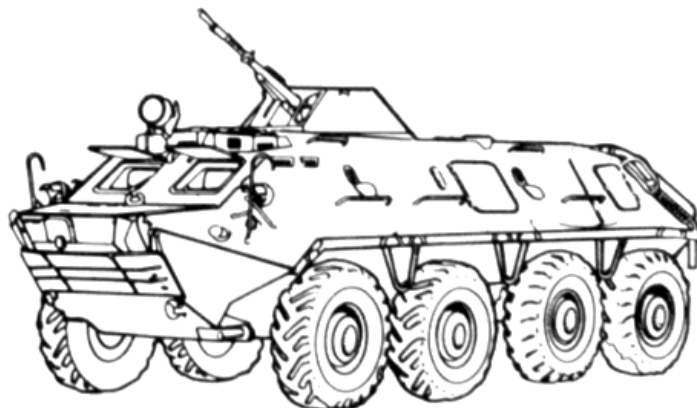

BTR-60PB Armored Personnel Carrier

The traverse and elevation are manual, and thus are slower than on newer vehicles. Throughout the course of its history, the BTR-60 was produced in over 10 versions by almost 35 countries. There are hatches on the front deck for the driver and commander; the turret does not have a hatch. On the rear deck is a large hatch for the passengers (if closed-topped); this hatch is the primary method of ingress and egress for the passengers and gunner, since the two doors in the hull are very small and best suited for emergency use or as auxiliary firing ports. There are also two firing ports in each side of the hull. In the front of the vehicle is a winch with a capacity of 4.5 tons.

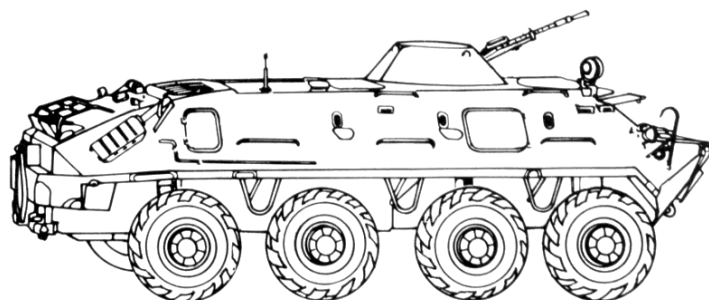

BTR-60PB Armored Personnel Carrier

The *Ludowe Wojsko Polskie* (LWP) used BTR-60PA APCs but since Polish/Czechoslovak OT-64 SKOT APC proved to be superior to BTR-60, it gave those away to *Milicja Obywatelska*. They were used by ZOMO riot control units and later by the Polish Police. Polish Army also received a number of command variants which were used within the Soviet supplied 9K33 Osa (SA-8 Gecko) SAM regiment delivered in 1980s. ZOMO special squads (An equivalent of modern Anti-Terrorist squads) also used BTR-60PB since early 1980s. These were later modified with additional radio. Some received breakers mounted to the front of the vehicle which were used for clearing obstacles. They were also used later

by Polish Police which used them for security during European Economy Summit 1994 in Warsaw.

Vehicle: BTR-60PB
Price: \$72,000 (- / R)
Range Finder: None
RF modifier: None
Armament: KPV, PKT

Stabilization: None
Ammo: 500x14.5,
2000x7.62
Fuel Type: G, A
Load: 1.2 tons
Veh Wt: 10.3 tons
Crew: 3+8
Mnt: 4
Night Vision: Active IR
Radiological: Enclosed

Movement Data

Travel Mov: 151/91
Combat Mov: 35/20/4
Fuel Cap: 290
Fuel Cons: 66

Combat Statistics

Config: CiH
Susp: W(4)
ERA Facings: None
Hull, Front: 2
Hull, Side: 2
Hull, Rear: 2
Turret, Front: 1
Turret, Side: 1
Turret, Rear: 1

Machineguns Weapon	-Recoil-							
	ROF	Dam	Pen	Blk	Mag	SS	Brst	Rng
KPV	5	11	2-2-3	13	105B	*	*	475
PKT	5	4	2-3-Nil	8	50B	*	*	202

BTR-60PB: The BTR-60PB is an eight-wheel-drive vehicle with a long, boat-like hull with well-sloped armor on the sides and overhead armor cover. The hull is of all-welded steel construction, with the driver and commander seated at the front, a personnel compartment in the mid-section, and the engine compartment at the rear of the hull. The BTR-60 has a fully enclosed troop compartment on top of which is a one-man turret. The small conical turret, placed over the second set of wheels, is identical to the one fitted on the BRDM-2. It mounts coaxial 14.5-mm KPV and 7.62-mm PKT machine guns to right, with a telescopic sight mounted coaxially on the left. The crew use two semicircular hatches forward of the turret, and a pair of rectangular hatches aft of the turret for access by up to eight passengers. Three firing ports are located on either side of the troop compartment.

This eight-wheel-drive vehicle has evenly spaced wheels, except for a slightly larger space between the second and third wheels. The tires have the centralized pressure regulation system common to Soviet wheeled APCs, and are partially filled with a foam-

rubber-like substance. All eight wheels are powered, and the first four which are used for steering, are power-assisted. The rear-mounted power plant employs a pair of 6-cylinder 90-hp gasoline engines mounted at the rear of the hull. The first and third axles are powered through the transmission of the right engine and the second and fourth axles through the transmission of the left engine. The BTR-60P is fully amphibious, propelled by a single water-jet mounted at the rear of the hull.

Although its armor is thicker than that of older model APCs, the BTR-60PB is vulnerable to HE fragmentation as well as small arms fire. The tires are extremely vulnerable to puncture. Soft ancillary equipment (antennas and integral fuel tanks) are vulnerable to destruction by field artillery weapons. Troops must mount and dismount through the top hatches, which exposes them to fire. A notable vulnerability is that passengers have to exit the vehicle through top hatches, which makes them vulnerable to fires. Also, gunners must be at least shoulder high out of the vehicle to operate the mounted weapons.

TRACKED ARMORED VEHICLES

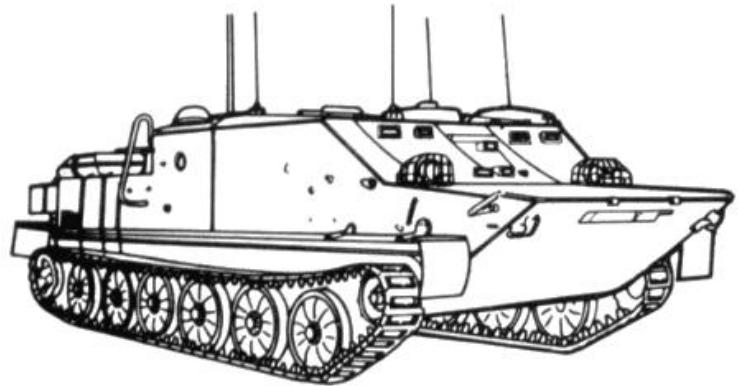

TOPAS-A Amphibious Armored Carrier

TOPAS (OT-62) The OT-62 is a tracked amphibious vehicle that was jointly developed and used by Czechoslovakia and Poland. It is equivalent to the Soviet BTR-50PK APC and in appearance is almost identical to the BTR-50PU model 2 command vehicle with some significant differences. These differences include higher road and water speeds, a fully enclosed troop compartment and in some versions, fully-enclosed armament installations rather than simple pintle-mounted machine guns. TOPAS is the official designation of this armored personnel carrier with the designation "OT-62" often being used in the West. The Western term "OT-62" will be used principally in this lesson.

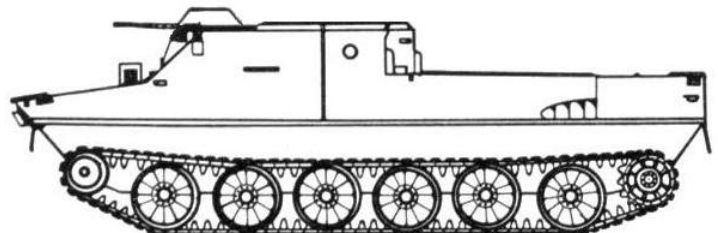

TOPAS-2A Armored Personnel Carrier. (Mortar Carrier similar)

This vehicle was conceived by Czechoslovakia and Poland as an upgraded version of the BTR-50PK, entering service in 1964 with Czechoslovakia and 1966 with Poland. The improvements over the BTR-50 include an NBC system, higher speeds, a fully enclosed weapon station, and doors in the sides of the passenger compartment. There are at least 8 variants, including several APCs with different armament, a recovery vehicle, an ambulance, and several command versions. They are still in service with the Czechs and Polish, as well as Bulgaria, Iraq, India, and several African nations. In addition, Israel captured almost 100 of them during several past wars and equipped some of their reserve units with OT-62s. The T-21 is a Czech/Polish version of the Russian B-10 recoilless rifle.

Vehicle: TOPAS-2A	TOPAS-2AP	TOPAS Mortar Carrier
Price: \$66000 (-/R)	\$70000 (-/R)	\$90000 (-/R)
Range Finder: None	Optical	None
RF modifier: None	+1	None
Armament: PKT, T-21	KPV, PKT	PKT, M-43
Stabilization: None	Basic	None
Ammo: 1250x7.62, 12x82	500x14.5, 2000x7.62	1250x7.62, 80x120
Fuel Type: D, A	D, A	D, A
Load: 1 ton	1 ton	1 ton
Veh Wt: 15 tons	16.39 tons	15 tons
Crew: 2+18	3+12	8
Mnt: 9	9	9
Night Vision: Active IR	Active IR	Active IR
Radiological: Enclosed	Enclosed	Enclosed

Movement Data

Travel Mov: 129/90/22	120/84/20	129/90/22
Combat Mov: 30/20/5	25/20/4	30/20/5
Fuel Cap: 417	520	417
Fuel Cons: 88	88	88

Combat Statistics

Config: Stnd	CiH	Stnd
Susp: T3	T3	T3
ERA Facings: None	None	None
Hull, Front: 3	3	3
Hull, Side: 2	2	2
Hull, Rear: 2	2	2
Turret, Front: -	2	-
Turret, Side: -	2	-
Turret, Rear: -	2	-

Machineguns

Weapon	-Recoil-							
	ROF	Dam	Pen	Blk	Mag	SS	Brst	Rng
KPV	5	11	2-2-3	13	105B	*	*	475
PKT	5	4	2-3-Nil	8	50B	*	*	202

Mortars

Type	Round	Min	Damage	Pen	IFR
120mm M-43	CHEM	460	C3 B12	Nil	5700
Rld: 1	HE	480	C16 B44	0C	5700
	ILLUM	480	B1500	Nil	5700
	WP	480	C3 B36	Nil	5700

TOPAS-2AP (OT-62C)- This version has a turret similar to the Soviet BTR-60PB. Main armament is a 14.5-mm heavy machine gun mounted in the turret over the troop compartment. Secondary armament is a coaxially-mounted 7.62-mm machine gun. A practical rate of fire for the 14.5-mm gun is 150 rds/min with a basic load of 500 rounds. A practical rate of fire for the 7.62mm gun is 200 rds/min with a basic load of 1,000 to 2,000 rounds. This version and the modified OT-62C version below are used only by the Polish Armed Forces within the Warsaw Pact.

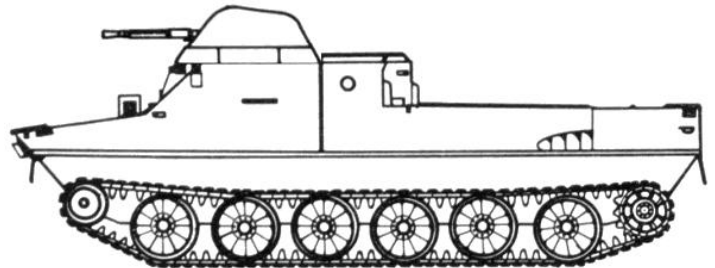

TOPAS-2AP Armored Personnel Carrier

BWP-1 The Bojowy Wóz Piechoty - 1 or "Infantry Fighting Vehicle - 1 is the Polish designation for Soviet BMP-1 (Ob'yekt 765Sp2 and later Ob'yekt 765Sp3). The BWP-1 has been produced locally since the beginning of the 1970's and remains a vital part of Poland's mechanized units.

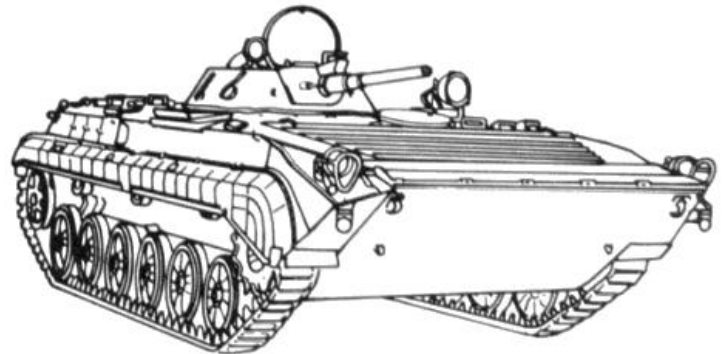

BWP-1 Infantry Fighting Vehicle

Wojska Lądowe
Sourcebook

Vehicle:	BWP-1	BMP-1 Puma	BWP-1 Puma E-8
Price:	\$197000 (S/R)	\$205000 (R/-)	\$347000 (R/-)
Range Finder:	None	Optical	
RF modifier:	+1	+2	+2
Armament:	73mm LCG, PKT, AT-3	73mm LCG, PKT, AGS-17 (C), AT-5	30mm AC, AGS-17, PKT, AT-5
Stabilization:	Fair	Fair	Good
Ammo:	40x73, 2000x7.62, 5xAT-3	40x73, 2000x7.62, 200x30GL, 4xAT-5	500x30, 350x30GL, 2000x7.62, 4xAT-5
Fuel Type:	D, A	D, A	D, G, AvG, A
Load:	1 ton	1 tons	1.5 tons
Veh Wt:	13.5 tons	13.55 tons	14.5 tons
Crew:	3+8	3+8	3+7
Mnt:	8	8	8
Night Vision:	Passive IR, Searchlight	Passive IR, Searchlight	TI, Passive IR, Image Inte.
Radiological:	Shielded	Shielded	Shielded

Movement Data

Travel Mov:	145/102	105/74	102/72
Combat Mov:	30/20/3	25/15/2	20/15/2
Fuel Cap:	460	460	462
Fuel Cons:	111	92	94

Combat Statistics

Config:	Trtd	CiH	Trtd
Susp:	T2	T2	T2
ERA Facings:	None	None	HF, HS
Hull, Front:	8	8	8
Hull, Side:	4	4	4
Hull, Rear:	4	4	4
Turret, Front:	10	4	10
Turret, Side:	6	4	6
Turret, Rear:	6	4	6

Machineguns

-Recoil-

<i>Weapon</i>	<i>ROF</i>	<i>Dam</i>	<i>Pen</i>	<i>Blk</i>	<i>Mag</i>	<i>SS</i>	<i>Brst</i>	<i>Rng</i>
PKT	5	4	2-3-Nil	8	50B	*	*	202

Large Caliber Guns

<i>Type</i>	<i>Round</i>	<i>Rng</i>	<i>Damage</i>	<i>Pen</i>	<i>IFR</i>
73mm	HE	240	C8 B20	4C	Nil
<i>Rld: 1</i>	HEAT	240	C5 B15	51C	Nil
AGS-17 AGL	HE	170	C2 B9	Nil	850
<i>Rof: 5</i>	HEDP	170	C2 B9	4C	850
30mm 2A42 AC	APDS	460	7	10/9/7/5	Nil
<i>Rof: 5</i>	API	460	7	6/5/4/3	Nil
	HE	350	C2 B10	-3C	Nil

ATGM

<i>Weapon</i>	<i>Round</i>	<i>Diff</i>	<i>Damage</i>	<i>Pen</i>	<i>Min</i>	<i>Max</i>
AT-3 (9M14MP1)	HEAT	DIF	C18 B40	108C	500	3000
<i>Rld: 1</i>						
AT-5 (9M113)	HEAT	AVG	C17 B40	129C	70	4000
<i>Rld: 6</i>						

The BWP-1 is a fully armored amphibious infantry combat vehicle (AICV). Its low silhouette hull has a sharp sloping front with a conspicuously ridged surface. A centrally located, extremely flat, truncated cone turret mounts a 73-mm smoothbore gun and a 7.62-mm coaxial machine gun. A launching rail for SAGGER missiles is attached above the gun. The 290 hp, water-cooled, 6-cylinder diesel engine is located at the right front, while the driver's hatch is at the left front, directly in front of the commander's hatch which mounts an IR searchlight. The gunner's hatch is on the left side of the low turret roof. To the rear of the turret there are four large hatches in the roof of the troop compartment, as well as two large exit doors in the rear. There are four firing ports in each side of the troop compartment and one in the left rear door. The suspension has six unevenly spaced road wheels of the PT-76 type, with three track support rollers and a front drive sprocket.

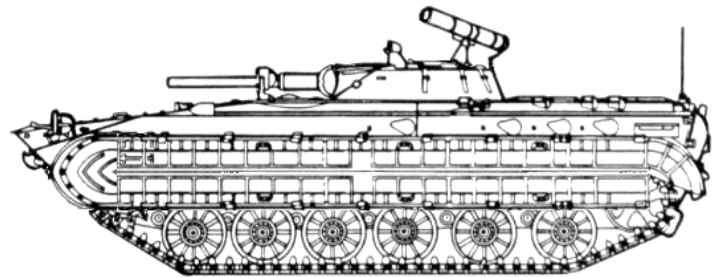

BWP Puma I

BWP-1M "Puma 1" Polish modernization of BWP-1. It has anti-slip covering in order to protect the crew from slipping while walking on the armour, an independent system for heating the crew compartment, engine compartment and fuel compartment, fire and explosion protection systems, knives for crew members to fight infantry trying to disable the vehicle while it is driving with its top hatches opened, way clearing system, night vision device for the driver, electrical system adjusted to connect to a firing simulator, new improved integrated NBC protection system, flotation side-skirts, a laser radiation warning system, a power unit module enabling its quick replacement in field conditions, modernised vision device for the commander.

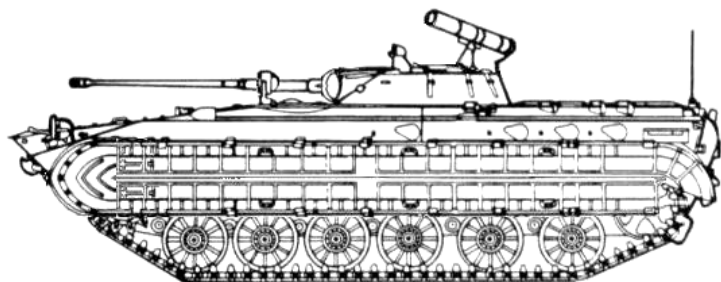

BWP Puma II

BWP "Puma II" Polish modernization of BWP-1 with all the improvements from the BWP-1M except it has thirteen 81 mm shrapnel grenade launchers instead of six (three on the left hand side of the turret, three on the left hand side of the hull, three on the right hand side of the hull and four on the right hand side of the

turret) and the new slab-sided one-man E-8 turret armed with 30 autocanon. It has a large ammunition drum with outboard machine gun mount on right hand side of the main armament. It also has wire cutters installed on the top of each side of the hull.

MT-LB Multipurpose Armored Vehicle The MT-LB amphibious armoured tracked vehicle is fully amphibious, propelled in the water by its tracks. The low-silhouette MT-LB has a flat-track suspension consisting of six road wheels with no return rollers. The box-like welded steel plate hull has a crew compartment at the front, engine immediately behind on the left side, and a troop compartment at the rear which has inward-facing folding canvas seats for 10 infantrymen. The flat hull roof has two forward opening troop exit hatches. The infantry enter and leave the vehicle by two rear doors which are provided with firing ports. The total of four firing ports also include one on each side of the vehicle. The small turret to the right of the commander's position mounts a single 7.62-mm machine gun. Standard equipment on all vehicles includes an NBC protection system.

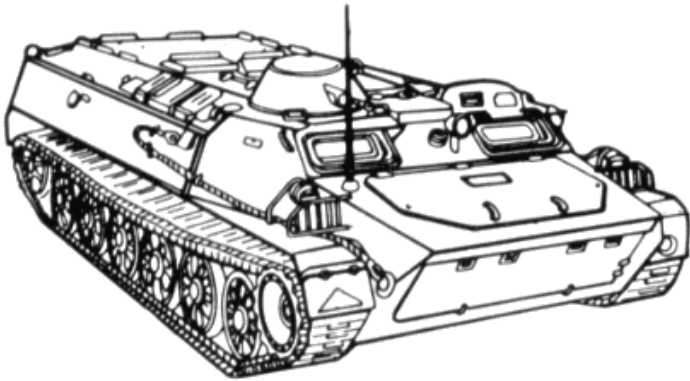

MT-LB Armored Personnel Carrier

The MT-LB is a multipurpose vehicle. When used as an ARC or command vehicle, it can carry ten personnel besides its two-man crew (driver and commander-gunner). It also is used as a prime mover for various types of artillery. In this case it can also carry the artillery crew (six to ten personnel). It is frequently used as prime mover for the 100-mm antitank gun T-12. As a cargo and general transport vehicle, it has a cargo capacity of 2.0 metric tons (towed load 6.5 metric tons). The wide-tracked MT-LBV is used as a soft-terrain vehicle.

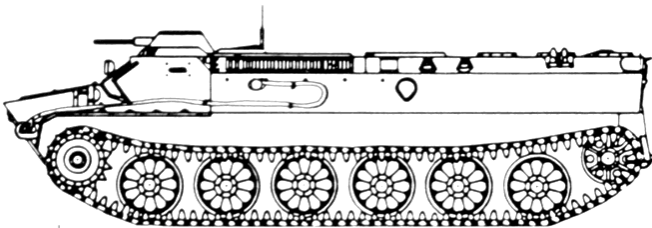

Basic ML-TB Chassis

This vehicle was not originally meant to be an armored personnel carrier; instead, it was designed to be a versatile chassis that could be easily modified for a variety of roles, from artillery tractor to

command vehicle. There are almost 40 variants of the MT-LB in service worldwide today, including many APC variants; they are valued in that role due to their size and surefootedness on uneven terrain. They also have a very good heating system, as one of the roles the MT-LB was designed for was to replace several over-the-snow vehicles used in Arctic and Siberian conditions. The treads can be replaced with tracks almost twice as wide as normal for even better performance in snow and swamps. On the front deck is a hatch for the driver and a small turret above the commander's position with a machinegun. Next to this small cupola is a hatch for the commander. The base version also has two large hatches on the rear deck, two doors in the rear face, and four firing ports, one on each side of the passenger area and one in each rear door.

MT-LB - basic APC variant fitted with an additional cupola with DShK-M.

WEM "Lotos" - medical evacuation vehicle with 4 stretchers.

Vehicle:	MT-LB	WEM "Lotos"
Price:	\$47000 (S/R)	\$60000 (R/-)
Range Finder:	Optical	Optical
RF modifier:	+1	+1
Armament:	DShK, PKT	DShK, PKT

Stabilization:	Fair	Fair
Ammo:	1000x12.7, 2500x7.62	1000x12.7, 2500x7.62
Fuel Type:	D, A	D, A
Load:	2.2 tons	1.6 tons
Veh Wt:	11.9 tons	11.4 tons
Crew:	2+11	3+8 Seated or 4 Stretchers
Mnt:	5	7
Night Vision:	Passive IR	Headlights
Radiological:	Shielded	Shielded

Movement Data

Travel Mov:	133/93	133/93
Combat Mov:	30/20/2	30/20/2
Fuel Cap:	450	450
Fuel Cons:	71	71

Combat Statistics

Config:	Std	CiH
Susp:	Std	Std
ERA Facings:	T3	T3
Hull, Front:	4	4
Hull, Side:	2	2
Hull, Rear:	2	2

Machineguns Weapon	-Recoil-							
	ROF	Dam	Pen	Blk	Mag	SS	Brst	Rng
DShK (APDS)	5	9	1-1-1	10	105B	*	*	388
PKT	5	4	2-3-Nil	8	50B	*	*	202

MAIN BATTLE TANKS

T-72 Main Battle Tank. Polish industry produced various versions of the Soviet designed T-72 MBT. Poland also based its

first indigenous tank design, the PT-91 Twardy, off the locally built T-72. All of the modernized variants of the T-72 were designed to be highly reliable systems having superior firepower, improved crew protection and impressive mobility over the Soviet originals.

Vehicle:	PT-91 Twardy	T-72M1Z Wilk
Price:	\$772000 (R/-)	\$554000 (R/-)
Range Finder:	Laser	Laser
RF modifier:	+4	+3
Armament:	125mm gun, PKT, DShK (C)	125mm Gun, PKT, DShK (C)
Stabilization:	Good	Good
Ammo:	45x125, 2000x7.62, 300x12.7	45x125, 2000x7.62, 300x12.7
Fuel Type:	D, A	D, A
Load:	500 kg	500 kg
Veh Wt:	46 tons	48 tons
Crew:	3	3
Mnt:	17	17
Night Vision:	Image Int. or TI	Image Int. or TI
Radiological:	Shielded	Shielded

Movement Data

Travel Mov:	113/79	148/103
Combat Mov:	25/15	33/22
Fuel Cap:	1000+400	1000+400
Fuel Cons:	428	502

Combat Statistics

Config:	Trtd	Trtd
Susp:	T6	T6
ERA Facings:	HF,HS,TF,TS	HF,HS,TF,TS
Hull, Front:	149C (229)	151C (231)
Hull, Side:	20S (108)	20S (108)
Hull, Rear:	10	12
Turret, Front:	119C (189)	120C (200)
Turret, Side:	28 (108)	27 (107)
Turret, Rear:	16	19

Machineguns

Weapon	Recoil-							
	ROF	Dam	Pen	Blk	Mag	SS	Brst	Rng
DShK (APDS)	5	9	1-1-1	10	105B	*	*	388
PKT	5	4	2-3-Nil	8	50B	*	*	202

Large Caliber Guns

Type	Round	Rng	Damage	Pen	IFR
125mm	APFSDS	470	28	124/108/92/59	Nil
Rld: 2	HE	350	C27 B35	12C	Nil
	HEAT	350	C18 B25	118C	Nil
	APFSDSDU	470	28	155/135/115/74	Nil

In April 1951 the Stalin Mechanical Factory in Labedy (abbreviated later as ZMIS), was erected with the purpose of producing heavy tracked vehicles such as tanks, agricultural and artillery tractors, excavators and cranes. The name of the factory and sometimes structure was a matter of change several times within the space of these years. In 1956 the name was shortened to Mechanical Factory "Labedy" in Labedy, and after joining the Labedy to Gliwice of course appeared name in Gliwice. In the years from 1951 to 1956 were produced tanks of T-34 type, later

T-54 type that were produced until 1964 and next, after upgrading, tanks of T-55A type until 1969. In this last period simultaneously started production of tanks of T-55 and T-55A type, which were produced until 1979. On the base of this tank new modification was constructed with new designation as Recovery Vehicle WZT-1 and WZT-2 and Engineering Vehicle in the Experimental Production Unit, later the Research and Development Centre of Mechanical Systems (OBRUM) in Gliwice. Regulation No.77 of Machine Industry Minister from December in 1975 established, on the basis of our Factory, Mechanical Equipment Industrial Complex "Bumar - Labedy" in Gliwice.

From 1980 Bumar produced the T-72, T-72M1 and its variations: commander tank T-72M1K and Recovery Vehicle WZT-3 and Mine Clearing Vehicle. The Gulf War revealed some defects of this tank never the less it is treated as a tank at the turn II and III generation of tanks. So it was upgraded using domestic research and development resources such as OBRUM (Research and Development Centre of Mechanical Systems), OPTA, WITU (Military Institute of Armament), WITPiS (Military Institute of Armored and Truck Vehicles) and constructed type PT-91 (Hard). Now it doesn't correspond fully to III generation of tanks but significantly approached to this. Bumar has produced this tank since 1993.

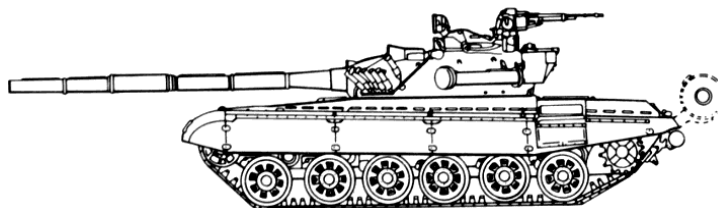

Basic T-72M without reactive armor package

T-72M (Ob'yekt 172M-E3) This model was build under licence by "Bumar-Labedy" in Gliwice. In Western sources the T-72M is often referred to as T-72G which might be the designator for the Middle East export version. Like Soviet tanks, the Polish T-72M was initially fitted with "gill armour"; later the tanks were upgraded with rubber side skirts and "Tucha" smoke grenade launchers. Late production models have the additional 16 mm steel plate welded on the upper glacis plate, like the T-72M1.

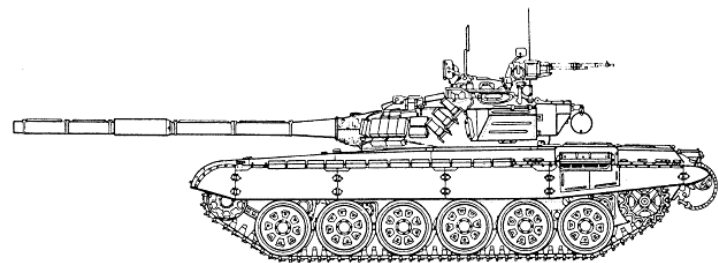

T-72M1 with 1st generation reactive armor on turret.

T-72M1 (Ob'yekt 172M-E5) - This export version of the T-72A was also build under licence in Poland. An external difference with the Soviet original is the reduced number of KMT mounts on the lower glacis plate.

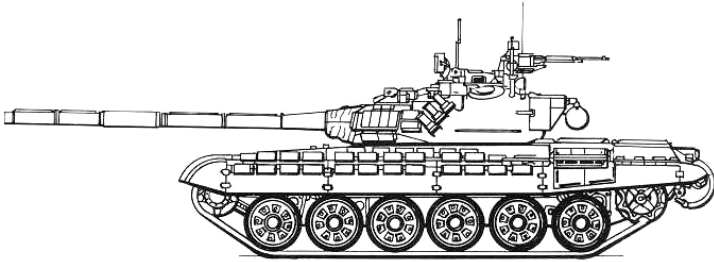

T-72M1Z Wolf with 1st generation reactive armor on turret and hull.

T-72M1Z Wilk (Wolf)- In 1986, the Polish T-72 Wilk project was instituted to allow the tank repair plants to upgrade T-72 tanks at their own facilities. In particular, it was proposed that the Soviet-made Volna fire control system be replaced by the Czechoslovak made Kladivo FCS or by the Polish Merida, both originally designed for T-55AM "Merida". Beside the new FCS, the Radomka illumination-free night vision devices were installed in the driver's compartment, as were the LIS-Varta night sight, Obrla laser illumination warning system, Tellur anti-laser smoke dischargers, solid or sectionalized metal side skirts and the Polish-developed Erawa-1 or Erawa-2 explosive reactive armour were also fitted. It was further developed as PT-91.

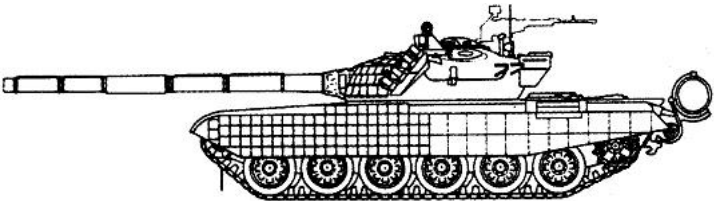

PT-91 fitted with 2nd generation reactive armor effective against tandem HEAT and APDS weapons.

PT-91 Twardy (Hard)- Starting in July 1991 T-72 modernization programs were implemented by the "Bumar" combine which had been serially producing the T-72 under Soviet license. The modernized main battle tank was designated PT-91 Twardy. From base modification it differs in increased defense, fire control system and engine. In 1993 the Polish Defense Ministry ordered 20 PT-91 tanks to be used for field trials and Armed Forces tests.

The main battle tank's defense from high-explosion projectiles and missiles is increased by the new Erawa dynamic second-generation reactive armor that is effective against both AP and HE attack. The system was developed by the Poland Military-Technical Institute and consists of 394 tiles with explosives, detonating in case of a direct hit. The tiles cover 9m² on the tank. 108 tiles are placed on the turret, 118 on the hull and 84 on each side's anti-cumulative screens. The Twardy uses steel anti-cumulative screens instead of the rubber used on the T-72. Erawa's main difference from the Soviet analogs is that Erawa's containers fit almost without gaps while on the Soviet modernised T-72 gaps reach 10 - 15 mm noticeably decreasing defense effectiveness. There are two Erawa modifications: Erawa-1 and -2, differing in weight of the explosives.

The Twardy is armed with the same 125-mm smoothbore gun 2A46 used in the T-72, fitted with an automatic reloading

mechanism which reduced the tank crew by one as it replaced the gun loader, and gave a rate of fire of 8 to 10 rounds per minute. Additional armament comprises the 7.62 mm PKT coaxial general purpose machine gun and 12.7 mm NSVT anti-aircraft heavy machine gun. The PT-91 has a thermosmoke device generating smoke screens from fuel and 24 grenade launchers fitted with smoke or anti-personnel frag grenades.

Vehicle:	T-72M1	T-72M
Price:	\$328000 (R/-)	\$324000 (S/R)
Range Finder:	Optical	Optical
RF modifier:	+2	+2
Armament:	125mm gun, PKT, DShK (C)	125mm Gun, PKT, DShK (C)
Stabilization:	Fair	Fair
Ammo:	45x125, 2000x7.62, 300x12.7	45x125, 2000x7.62, 300x12.7
Fuel Type:	D, G, AvG, A	D, G, AvG, A
Load:	500 kg	500 kg
Veh Wt:	42.6 tons	42 tons
Crew:	3	3
Mnt:	14	14
Night Vision:	Passive IR, WL/IR, Searchlight	Passive IR, WL/IR, Searchlight
Radiological:	Shielded	Shielded

Movement Data

Travel Mov:	145/102	146/103
Combat Mov:	30/20	30/20
Fuel Cap:	1000+400	1000+400
Fuel Cons:	579	579

Combat Statistics

Config:	Trtd	Trtd
Susp:	T6	T6
ERA Facings:	HF,HS,TF,TS	TF,TS
Hull, Front:	151C (231)	135C
Hull, Side:	20S (108)	20S
Hull, Rear:	12	12
Turret, Front:	120C (200)	105 (185)
Turret, Side:	27 (107)	27 (107)
Turret, Rear:	19	19

Machineguns

Weapon	-Recoil-							
	ROF	Dam	Pen	Blk	Mag	SS	Brst	Rng
DShK (APDS)	5	9	1-1-1	10	105B	*	*	388
PKT	5	4	2-3-Nil	8	50B	*	*	202

Large Caliber Guns

Type	Round	Rng	Damage	Pen	IFR
125mm	APFSDS	470	28	124/108/92/59	Nil
Rld: 2	HE	350	C27 B35	12C	Nil
	HEAT	350	C18 B25	118C	Nil
	APFSDSDU	470	28	155/135/115/74	Nil

The Drawa fire control system, developed by Polish engineers, contains the gunner's day sight PCD and the TES thermovision night sight developed by the Israeli company ELOP, the commander's combined day-night passive observation and aiming

sight POD-72, a ballistic computer, a laser rangefinder and a data system processing information for the ballistic computer. The sighting of the ballistic computer depends on the target's speed, weather conditions, projectile temperature and projectile type.

The modernized tank's increased weight led the developers to add a more powerful engine. It is a 12 cylinder S-12U diesel engine, a modernized version of the Soviet V-46-6 produced in Warsaw by PZL-Wola (850 hp instead of 780). The main improvement is the modernized fuel and air injection system. This caused a noticeable decrease in the tank's road endurance. The latest Twardy variants have the 1000hp S-1000 engine with a turbocharger.

T-55 Main Battle Tank- The layout of the T-54 is conventional, with the main armament comprising a 100mm rifled gun. The T-54 has been used more than any other tank since the Second World War. It is intended for combat actions involving tanks, combat vehicles, armoured personnel carriers and other armored enemy targets. The T-55 combines a high velocity gun with exceptional long-range endurance. The T-55 has a fully tracked, five-road-wheeled chassis with a low-silhouetted hull and a dome shaped turret.

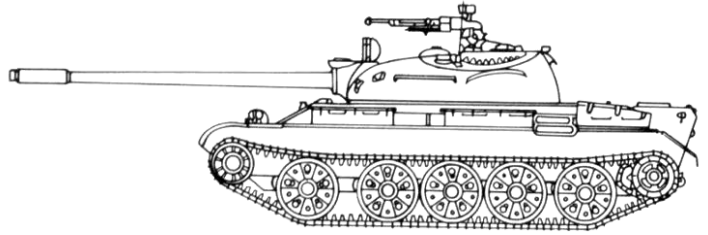

Basic T-55L without side skirts or reactive armor

The T-55 medium tank has a fully tracked, five-road wheeled chassis with a space between the first and second road wheels and no return rollers. It has a low-silhouetted hull with a dome-shaped turret mounted over the third road wheel. The 100-mm rifle-bore main gun has a bore evacuator at the muzzle. A 7.62-mm coaxial machine gun and 7.62-mm bow machine gun are also mounted. The later T-55A version lacks the bow machine gun.

The T-55 is distinguishable from the other T-54 models in that it lacks the right-hand cupola and the turret dome ventilator located in front of that cupola on the T-54. Most T-55s also lack the turret-mounted 12.7-mm AA machine gun of the T-54, and all T-55s mount an infrared gunner's searchlight above and to the right of the main gun. This searchlight, however, is not a distinguishing feature, since it has been retrofitted to many T-54 and T-54A tanks.

The T-55 combines a high-velocity gun with a highly mobile chassis, a low silhouette, and exceptional long-range endurance. Improvements over the T-54 include a larger V-12 water-cooled diesel engine with 580 hp rather than 520 hp, increased cruising range of 500km (up to 715 km with two 200-liter auxiliary fuel tanks which can be carried on the rear) rather than 400 km (600 km with auxiliary tanks). The T-55 also has two-plane stabilization of the main gun rather than vertical stabilization only, and a basic load for the main gun of 43 rounds rather than 34.

The T-55, which can ford depths of 1.4 meters without preparation, has snorkel equipment which enables it to cross depths of up to 5.5 meters at a speed of 2 km/hr. This equipment takes about 15 to 30 minutes preparation but can be jettisoned immediately on leaving the water. All T-55s have the PAZ radiation detection system, and the T-55A also has an anti-radiation liner. Some T-55s also may have been retrofitted with a full NBC collective protection system (air filtration and overpressure). A dense smoke screen can be generated by injecting vaporized diesel fuel into the exhaust system.

T-55s with "bra armor", semi-circular add-on armor, have turret protection increased to 330 mm (KE) and 400-450 mm (CE). Other improvements available include a hull bottom reinforced against mines, better engines, rubber track pads, and a thermal sleeve for the gun. The 1K13 sight is both night sight and ATGM launcher sight; however, it cannot be used for both functions simultaneously. Optional sights and fire control systems include the Israeli El-Op Red Tiger and Matador FCS, Swedish NobelTech T-series sight, and German Atlas MOLF. The Serbian SUV-T55A FCS, British Marconi Digital FCS, South African Tiger, and Belgian SABCA Titan offer upgraded function. One of the best is the Slovenian EFCS-3 integrated FCS.

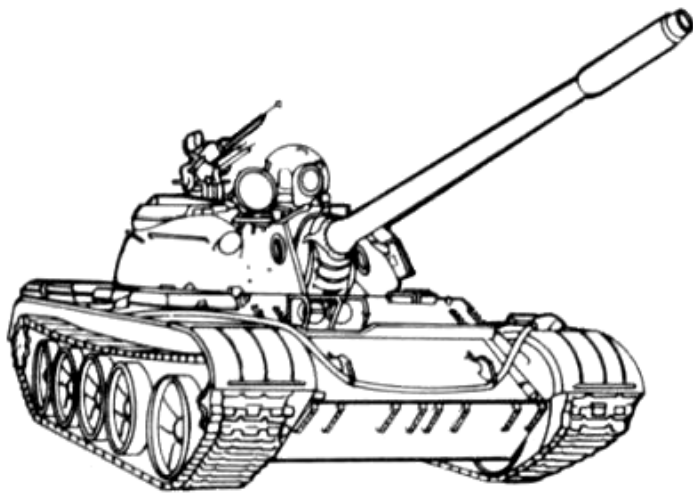

Polish produced T-55L Main Battle Tank

Poland produced 3,000 T-54, T-54A, T-54AD and T-54AM between 1956 and 1964 and 5,000 T-55 (between 1958 and 1964), T-55L, T-55AD-1 and T-55AD-2 between 1964 and 1979. Polish-produced tanks often have different stowage arrangements. The arrangement includes a rectangular box mounted on the left side of the turret, a smaller square stowage box on the left side of the turret-rear, and a slightly different rear decking.

The layout of the T-54 is conventional, with the main armament comprising a 100mm rifled gun. The T-54 has been used more than any other tank since the Second World War. It is intended for combat actions involving tanks, combat vehicles, armoured personnel carriers and other armored enemy targets. The T-55 combines a high velocity gun with exceptional long-range endurance. The T-55 has a fully tracked, five-road-wheeled chassis with a low-silhouetted hull and a dome shaped turret.

A variety of thermal sights is available. They include the Russian/French ALIS and Namut-type sight from Peleng. There are thermal sights available for installation which permit night launch of ATGMs.

Vehicle:	T-55L	T-55AM2BP	T-55AM "Merida"
Price:	\$314000 (R/S)	\$304000 (R/S)	\$360000 (-/R)
Range Finder:	Optical	Laser	Digital
RF modifier:	+1	+2	+3
Armament:	100mm Gun, PKT, DShK (L), DShK (C)	10mm D-10T Gun, PKT, NSVT (C)	10mm D-10T Gun, PKT, NSVT (C)
Stabilization:	Fair	Fair	Fair
Ammo:	49x100, 3000x7.62, 500x12.7	45x125, 2000x7.62, 300x12.7	45x125, 2000x7.62, 300x12.7
Fuel Type:	D, A	D, A	D, A
Load:	400 kg	400 kg	400 kg
Veh Wt:	36.2 tons	38.5 tons	40.5 tons
Crew:	4	4	4
Mnt:	12	22	13
Night Vision:	Active IR, IR Searchlight	Passive IR, Image Inten., Searchlight	Passive IR, IR Searchlight
Radiological:	Shielded	Shielded	Shielded

Movement Data

Travel Mov:	98/68	128/90	54/38
Combat Mov:	23/16	26/20	14/10
Fuel Cap:	960+380	812+380	960+380
Fuel Cons:	243	263	318

Combat Statistics

Config:	Trtd	Trtd	Trtd
Susp:	T6	T6	T6
ERA Facings:	None	TF, HF	TF, TS, HF, HS
Hull, Front:	67	54S (134)	72S (152)*
Hull, Side:	16	12S	20S (100)*
Hull, Rear:	8	8	10
Turret, Front:	54	43S (123)	58S (138)*
Turret, Side:	22	14S	28S (108)*
Turret, Rear:	13	11	16

Machineguns

Weapon	-Recoil-							
	ROF	Dam	Pen	Blk	Mag	SS	Brst	Rng
DShK (APDS)	5	9	1-1-1	10	105B	*	*	388
PKT	5	4	2-3-Nil	8	50B	*	*	202

Large Caliber Guns

Type	Round	Rng	Damage	Pen	IFR
100mm D-10	APFSDS	360	22	97/84/71/56	Nil
<i>Rld: 2</i>	HVAPDS	360	22	82/72/61/39	Nil
	APC	360	22	46/40/34/22	Nil
	AP	360	22	40/35/30/19	Nil
	APHE	360	C8 B15	40C	Nil
	HEAT	270	C10 B20	73C	Nil
	FRAG-HE	270	C11 B30	6C	Nil
	HE	270	C15 B25	8C	Nil

The T-55 is not airtight. Although crew members are protected from radioactive dust by the filtration system, they must wear

individual protective masks and clothing to guard against chemical and biological agents. The tank must thus pass through contaminated areas rapidly and then be decontaminated before it is fully operational.

The tank can be made watertight for fording water obstacles up to 1.4 meters deep (5.5 meters with snorkel). However, it may take up to half an hour to prepare a medium tank unit for a snorkeling operation, and entrance and exit points may also require preparation.

T-55L - New-build Polish versions of the T-55A with upgraded NBC protection and an infrared searchlight. The 100mm gun is stabilized vertically only.

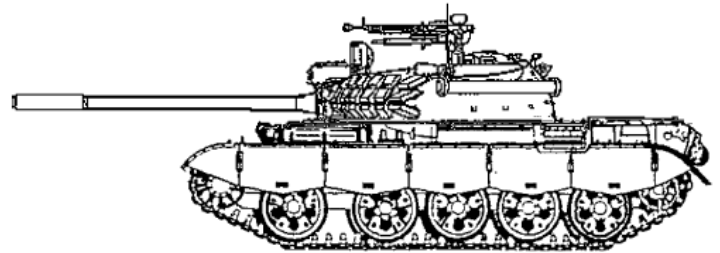

T-55AM Merida with upgraded ballistic computer, side skirts and second generation reactive armor

T-55AM "Merida" - Polish version of T-55AM developed between late 1970s and early 1980s, fitted with a new SKO (SKO stands for System Kierowania Ogniem - fire control system) fire control system with cross-wind sensor and a new CCDN-1 (CCDN stands for celownik-dalmierz dzienno-nocyj - day/night sight-rangefinder) day/night sight-rangefinder system. The tank is also equipped with additional passive armour (type BDD) on the hull and turret front, and with a protection system that consists of a laser-warning system WPL-1 "Bobrawa" (Wykrywacz Promieniowania Laserowego) and WWGD-1 "Erb" (Wyrzutnia Wybuchowych Granatów Dymnych) and WPD-1 "Tellur" (Wyrzutnia Pocisków Dymnych) 81 mm smoke grenade launchers, both in clusters of 8 on each side of the turret. Finally, the original engine has been replaced by an upgraded W-55 WAX developing 613 hp (457 kW).[37] Some were fitted with new radio sets like the R-123 or R-173. Considered to be a second generation MBT because of the high degree of modernization.

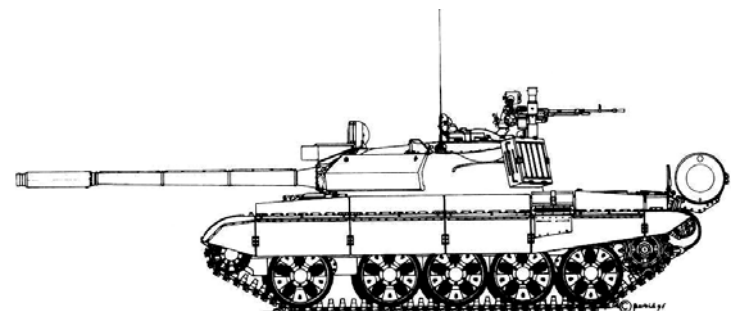

T-55AM with additional armor and side skirts

T-55AM2BP - This is a modernized T-55. The T-55 was built by Poland in 1950s by the thousands; by the early 1990s, Poland had

come up with an upgrade package that basically carries out almost every modification done on Warsaw Pact tanks through the decades. They then offered this upgrade package for export, and modified a large number of their T-55s to this standard.

The upgrades begins with appliqué armor to the turret and hull; for the turret, this is similar to the "horseshoe" armor first fielded by the Russians in the 1960s, but is also spaced. The added hull armor consists of spaced steel plates for the glacis and lower nose, and side skirts that also incorporate spaced armor; in addition, extra belly protection is provided. The gun is the same 100mm rifled gun, but a thermal sleeve is added to prevent warping under sustained fire. Rubber parts are largely replaced with hard vulcanized rubber, ceramic, or metal to increase protection against napalm-type flammables and Molotov cocktails. A screen is provided for the engine for the same reason. On either side of the rear of the turret is a bank of seven smoke grenade launchers. The engine has been modified to increase the output to 610 horsepower. The suspension is modified to provide a smoother ride; this also contributes to firing on the move. The tracks have been redesigned to nearly double their life. Finally, a laser rangefinder has been added, and the gun given more stabilization.

ARTILLERY

The 100 mm field gun M1944 (BS-3)- (Russian: 100-мм полевая пушка обр. 1944 г. (БС-3)) was a Soviet 100 mm anti-tank and field gun. The gun was successfully employed in the late stages of World War II, and remained in service into the 1950s, being replaced in Soviet service by the T-12 antitank gun and the 85 mm antitank gun D-48 in 1955. The BS-3 was also sold to a number of other countries and in some of these countries the gun is still in service. A number of BS-3 pieces are still stored in Russian Army arsenals.

Field Gun

Weapon	Round	Rng	Damage	Pen	IFR
100mm L/53	AP	360	22	40/35/30/19	21000
Rld: 2	APC	360	22	46/40/34/22	21000
	APFSDS	360	22	97/84/71/56	21000
	APHE	360	C8 B15	40C	21000
	FRAG-HE	270	C11 B30	6C	21000
	HE	270	C15 B25	8C	21000
	HEAT	270	C10 B20	73C	21000
	HVAPDS	360	22	82/72/61/39	21000

Gun:	D-10 100mm L/53 Gun
Crew:	8
Set Up:	5 minutes
Weight:	3.66 tons
Gun Shield:	2
Price:	\$16,800 (-/S)

The BS-3 was based on a B-3 naval gun. The development team was led by V. G. Grabin. The gun was employed by light artillery brigades of tank armies (20 pieces along with 48 ZiS-3) and by

corps artillery. In the Second World War the BS-3 was successfully used as a powerful anti-tank gun. It was capable of defeating any contemporary tank at long range. The gun was also used as a field gun. Less powerful than the 122 mm A-19, the BS-3 was more mobile and had a higher rate of fire.

122mm Towed Howitzer M-30-In 1930 Red Army (RKKA) authorities started to look for a new divisional level howitzer to replace the pre-World War I 122-mm howitzer M1909 and 122-mm howitzer M1910. Although both pieces were eventually modernized, resulting in the 122-mm howitzer M1909/37 and the 122-mm howitzer M1910/30 respectively, these upgrades did not address some shortcomings in the original designs.

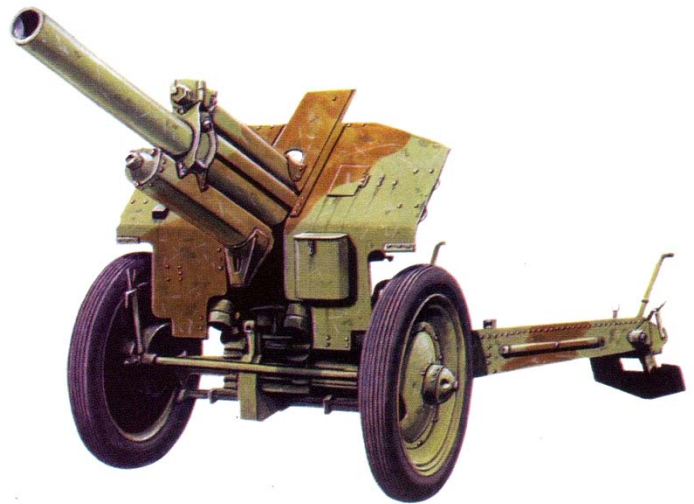

The first attempt to develop a new howitzer was made by the KB-2 design bureau under the supervision of German engineers. The design, known as Lubok, reached trials in 1932 and in 1934 was adopted as 122-mm howitzer model 1934. It had a 23 caliber long barrel, a maximum elevation of 50°, a traverse of 7°, and a combat and travelling weight of 2,250 and 2,800 kg respectively. Like its predecessors, Lubok had a fixed trail carriage and although it was equipped with suspension, its wheels lacked tires, limiting towing speed to only 10 km/h. Nevertheless, it was undoubtedly superior to the M1910/30 which remained in production until 1941. However, after eight pieces were built in 1934-1935, production was stopped for unclear reasons, possibly relating to the disbanding of KB-2.

In the mid-1930s, the Main Artillery Directorate (GAU) considered a transfer to 105 mm caliber guns, as used by some other armies. A smaller caliber meant that the gun could be lighter and consequently more mobile. On the other hand, a 105 mm gun would also be less powerful. Moreover, 105 mm caliber ammunition was new for Russia/USSR, while for the 122 mm the country already possessed both production lines and large numbers of already manufactured shells (but similar 107 mm caliber manufacturing equipment and ammunition — for the 107-mm gun

M1910 — were available). Finally in 1937 the RKKA Head of General Staff I. I. Egorov supported the 122 mm caliber.

Howitzer

<i>Weapon</i>	<i>Round</i>	<i>Rng</i>	<i>Damage</i>	<i>Pen</i>	<i>IFR</i>
122mm M-30	CHEM	270	C3 (B30)	Nil	15000
<i>Rld: 7</i>	HE	270	C30 B40	11C	15000
	HEAT	270	C20 B25	139C	15000
	ILLUM	Nil	(B1825)	Nil	15000
	ICM	Nil	B35	Grenade	15000
	WP	270	C3 B35	Nil	15000

Gun: 122mm M-30 Howitzer
Crew: 8
Set Up: 4 minutes
Weight: 2.5 tons
Gun Shield: 1
Price: \$11,500 (R/S)

Consequently, three howitzers were tried out in 1938–1939. The design bureau of UZTM (Ural Heavy Machinery Plant, Russian: Уральский Завод Тяжёлого Машиностроения, УЗТМ), which was required by GAU to design the new howitzer, developed a piece designated U-2. Similar projects were privately undertaken by the design bureaus of Motovilikha Plants, headed by F. F. Petrov (M-30), and of the No. 92 plant under V. G. Grabin (F-25).

The U-2 (barrel length 21 calibers, chamber volume 3.0 litres, horizontal sliding breechblock from Lubok, muzzle brake, combat weight 2,030 kg) reached trials on 5 February 1939 and was rejected because of insufficient carriage strength and inferior ballistics. The F-25 project (barrel length 23 calibers, chamber volume 3.7 litres, horizontal sliding breechblock from Lubok, muzzle brake, combat weight 1,830 kg) was closed by GAU on 23 March 1939 as GAU considered it redundant to the M-30 which had reached trials earlier. The latter, after being returned several times for revision, was finally adopted in September 1939 as 122 mm divisional howitzer M1938 (Russian: 122-мм гаубица образца 1938 года (M-30)).

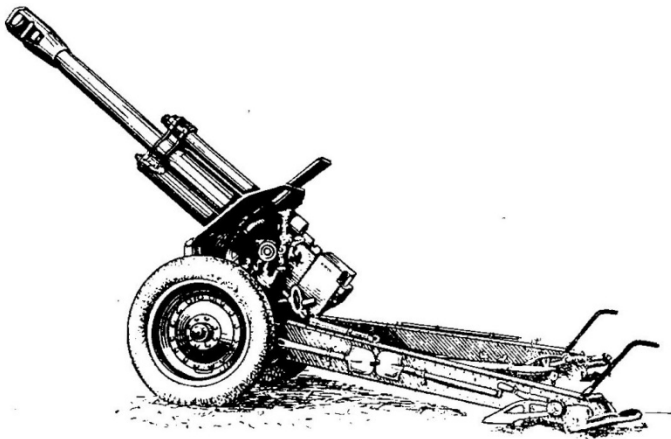

152mm Towed Howitzer D-20-The 152 mm howitzer M1955,

also known as the D-20 is a manually loaded, towed 152 mm artillery piece, manufactured in the Soviet Union during the 1950s. It was first observed by the west in 1955 and was therefore known as the M1955. There is also a Chinese copy, called Type 66.

The D-20 gun-howitzer was developed shortly after the end of WW2 by the F. Petrov Design Bureau; it was intended to replace the pre-war 152 mm ML-20 howitzer (M1937). The barrel length of the gun is 25 calibers. The D-20 was the first 152-mm cannon system to incorporate a semiautomatic vertical-sliding-wedge breech block. The gun was also used for the self-propelled 2S3 Akatsiya. The D-20 is in operation in at least 13 countries and has been license manufactured in the People's Republic of China as the Type 66 (or the improved version Type 66-1). Its self-propelled version known as Type 83 was first introduced in the mid-1980s. Yugoslavia also produced a further developed gun called the M84 NORA-A.

Howitzer

<i>Weapon</i>	<i>Round</i>	<i>Rng</i>	<i>Damage</i>	<i>Pen</i>	<i>IFR</i>
152mm D-20	APHE	350	C23 B24	122C	19000
<i>Rld: 14</i>	CHEM	260	C3 (B30)	Nil	19000
	HEAT	260	C30 B30	175C	19000
	HEI	260	C24 B45	87C	19000
	ICM	Nil	B60	Grenade	19000
	ICM-DP	Nil	B60	Grenade*	19000
	ILLUM	Nil	(B2830)	Nil	19000
	WP	260	C3 B45	Nil	19000

Gun: D-20 152mm L/34 Howitzer
Crew: 8
Set Up: 6 minutes
Weight: 10.5 tons
Gun Shield: 2
Price: \$48,200 (-/S)

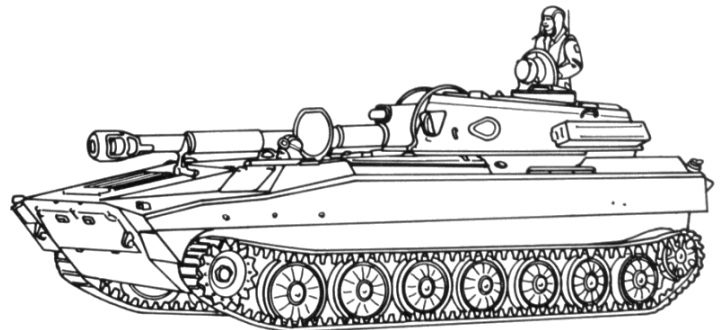

2S1 M-1974 Gvodzika (Carnation)-While the chassis of the 2S1 somewhat resembles that of the PT-76, it is essentially a new design, derived from the MT-LB chassis. The 2S1 has seven road wheels (versus six for either PT-76 or MT-LB) and no return rollers, with the drive sprocket at the front and the idler at the rear. As with the MT-LB, two different widths of track can be fitted, the

wider tracks lowering the ground pressure and facilitating travel over soft terrain. The amphibious 2S1 is driven through the water by its tracks.

The boat-like hull contains the engine compartment at the right front and the driver's compartment at the left front, with the driver's hatch to the left of the gun tube. The fighting compartment in the rear of the hull is topped by a low-silhouette, rotating turret. Atop the all-welded turret are the commander's cupola (with single hatch cover) on the left and the loader's hatch on the right. The gunner, also located in the left side of the turret, has no hatch. The commander and driver have IR night sighting equipment, but there is no IR gunnery equipment. An interesting feature on the turret is the tear-drop shaped port cover on the left front near the gunner's position. The 2S1 has a direct fire sight besides its panoramic telescope. The vehicle is fitted with a collective NBC overpressure and filtration protective system.

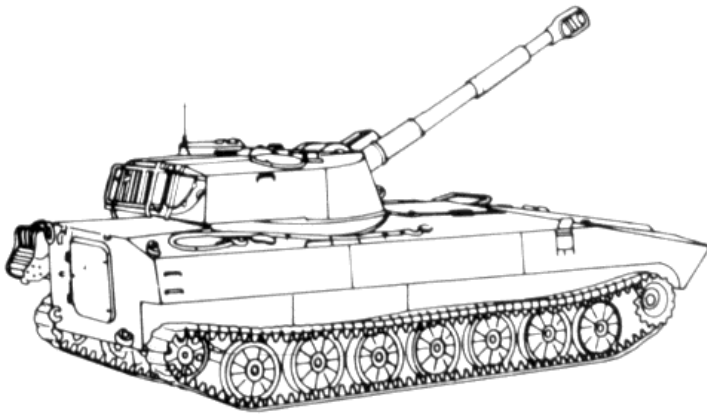

The long 122-mm howitzer mounted on the rounded front of the turret is derived from the towed 122-mm howitzer D-30. The double-baffle muzzle brake is flush with the forward edge of the hull, and the bore evacuator is located midway along the tube.

The 2S1 can be quickly distinguished from the 152-mm self-propelled howitzer 2S3 by the smaller turret and less massive gun on the 2S1. The 2S1 also has a single unit shield for the recoil-recuperator mechanism above the tube, while the 2S3 has two separate cylinders above the tube. Also, the tube of the 2S1 does not extend beyond the front of the vehicle, while the 2S3 tube does.

The 2S1 is found in the howitzer battalion of BMP-equipped motorized rifle regiments and some tank regiments. Since it is tracked and amphibious, it has the cross-country capability necessary to keep pace with supported BMPs and tanks. It has a maximum range of 15,300 meters and is also used extensively in a direct fire role against armored vehicles or to breach minefields and other obstacles.

Vehicle: 2S1 Gvozdika
Price: 188074
Range Finder: Optical
RF modifier: +1
Armament: 122mm L/40 D-30 Howitzer

Stabilization: Basic
Ammo: 40x122
Fuel Type: D, A
Load: 600 kg
Veh Wt: 15.7 tons
Crew: 4
Mnt: 8
Night Vision: Passive IR

Radiological: Shielded

Movement Data

Travel Mov: 127/89
Combat Mov: 25/20/3
Fuel Cap: 550
Fuel Cons: 110

Combat Statistics

Config: Trtd
Susp: T4
ERA Facings: None
Hull, Front: 4
Hull, Side: 2
Hull, Rear: 2
Turret, Front: 6
Turret, Side: 6
Turret, Rear: 6

Howitzer

<i>Weapon</i>	<i>Round</i>	<i>Rng</i>	<i>Damage</i>	<i>Pen</i>	<i>IFR</i>
122mm D-30	CHEM	270	C3 (B30)	Nil	15000
<i>Rld: 4</i>	CLGP	270	C30 B40	22C (TA)	15000
	HE	270	C30 B40	11C	15000
	HEAT	270	C20 B25	139C	15000
	HE-ERFB	270	C30 B40	11C	21000
	ICM	Nil	B35	Grenade	15000
	ICM-DP	Nil	B35	Grenade*	15000
	ILLUM	Nil	(B1825)	Nil	15000
	VHF Jammer	270	(B700)	Nil	15000
	WP	270	C3 B35	Nil	15000

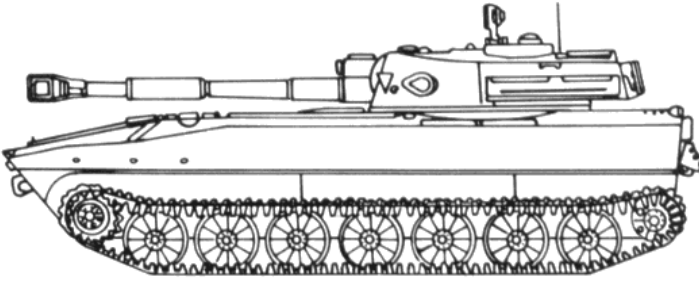

The vehicle has a relatively light weight of less than 16 metric tons, with a ground pressure of approximately 0.5 kg/cm². This enables it to operate in swamps and deep snow and also contributes to its amphibious capability. It is propelled by track drive in water as well as on land. The light weight and low profile also make air-lifting easier. The tightly sealed hull with its filtration system enables the 2S1 to operate in irradiated or contaminated zones as well as under heavy dust conditions. The turret is mounted with a ball-bearing race and has an electric drive for rapid traverse, although precise aiming is performed with a manual drive. A ramming mechanism speeds up the loading process, and fired cases are ejected automatically.

Because of its light weight, the 2S1 offers only slight armor protection for its four-man crew.

Since the 2S1 was seen in public for the first time in 1974, it also has been known under the provisional designation M1974. It also has been referred to as SP-74 and SAU-122. Although the 2S1 has been variously referred to as a gun, a gun-howitzer, or a howitzer, the Soviet press called it a howitzer. Its introduction coincided with the expansion of the Soviet motorized rifle regiment's artillery battery to a battalion and with the introduction of the ACRV M1974, which is associated with self-propelled artillery units. The self-propelled howitzer 2S1 provided the Soviet Army with highly mobile firepower that fit neatly into its doctrine of the offensive. It also was found in some non-Soviet Warsaw Pact armies, but this is rare. There is a large door in the rear of the hull to resupply the vehicle with ammunition.

Dana (Vzor 77)

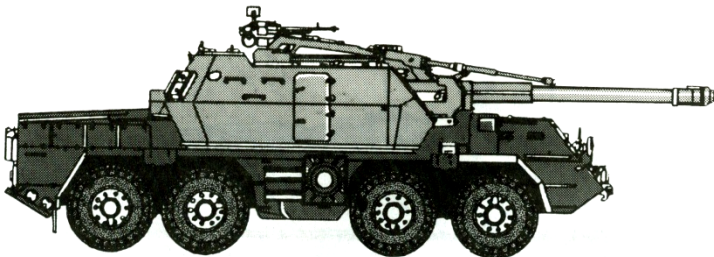

The Dana is an extensively modified Tatra T-815 Kolos truck chassis with a turret in the center mounting a 152mm howitzer. Aside from the turret, the most extensive modification is the fully armored body and the engine that has been moved to the rear of the vehicle. The turret may be traversed 112.5 degrees to the right and left of center. There is a modification of this vehicle with a 155mm NATO howitzer (the Zuzana), as well as a version with the turret

mounted on the chassis of a T-72 tank. The cab of the Dana has roof hatches for the driver and commander. The turret is divided into two compartments due to the combination of small turret and large gun, and each of these compartments has a door on the side of the turret and a roof hatch. In addition, on the right compartment of the turret (the smaller one), there is a small cupola mounting a heavy machinegun. This vehicle is in service with Czechoslovakia, Libya, and (in relatively small numbers) Poland. An overload of 60 howitzer rounds may be carried, but Travel Move and Combat Move is reduced by 10%.

The Dělo Automobilní Nabíjené Automaticky (self-propelled auto-loading gun), also known as Samohybná Kanónová Húfnica vzor 77 (ShKH-77) (self-propelled gun howitzer model 77) was designed by Konštrukta Trenčín and built by ZTS Dubnica nad Váhom in the former Czechoslovakia (now Slovakia) as the first wheeled 152 mm self-propelled artillery gun to enter service. It was introduced in the 1970s. It is based on the 8x8 Tatra 815 truck, the best off-road truck at the time. Currently it is in service with the Czech Republic, Libya, Poland, Georgia and Slovakia.

Wheeled vehicles have the advantage of being cheaper to build and easier to maintain with greater mobility. Tire pressure can be regulated to allow good mobility off-road and there is power-assisted steering on the front four wheels. It lowers 3 hydraulic stabilizers into the ground prior to firing, and has a roof mounted crane to assist with ammunition loading.

The crew of the DANA consists of the driver (operates the hydraulic stabilizers) and commander sitting in the front cabin, the gunner (aims the gun and opens fire) and loader operator (selects the appropriate amount of powder charges) are on the left side of the turret, the ammo handler (sets the shells' primers) is on the right side turret.

The DANA was designed in the 1970s by Konštrukta Trenčín to fill the role of an indirect fire support weapon without buying the Soviet 2S3 Akatsiya self-propelled artillery. In 1976 the team of designers finished work on the DANA project and production was passed to ZTS Dubnica nad Váhom.

It is a 152 mm gun mounted on an 8x8 Tatra T815 truck. It was a significant departure from traditional self-propelled guns as it used a wheeled carriage. It was accepted for service in 1981 and by 1994 over 750 units had been built.

DANA's unique feature is that its autoloader is able to load a shell and a cartridge in any elevation of the barrel. Although this feature is nowadays considered as standard, Dana was one of the first such artillery systems in the time of its introduction to service.

As there is no gyroscopic or similar system for independent, automated and autonomous gun laying of DANA, the gunner of DANA uses panoramic telescope with horizontal scale to set the appropriate horizontal laying via aiming at directing points. This means there needs to be other device to help gun laying of DANA (in fact, the firing positions of such artillery systems are usually prepared BEFORE the guns are stationed there). After laying the

Wojska Lądowe
Sourcebook

gun in horizontal plane, the gunner uses bubble level to set the desired gun elevation.

Vehicle: Dana

Price: 243749

Range Finder: Optical

RF modifier: +1

Armament: 152mm L/37 Howitzer, NSV

Stabilization: Basic

Ammo: 40x152, 300x12.7

Fuel Type: D, G, AvG, A

Load: 500 kg

Veh Wt: 28.1 tons

Crew: 5

Mnt: 8

Night Vision: Active/Passive IR

Radiological: Enclosed

Movement Data

Travel Mov: 122/73

Combat Mov: 29/17

Fuel Cap: 690

Fuel Cons: 126

Combat Statistics

Config: Trtd

Susp: W(4)

ERA Facings: None

Hull, Front: 6

Hull, Side: 5

Hull, Rear: 4

Turret, Front: 6

Turret, Side: 6

Turret, Rear: 6

Howitzer

<i>Weapon</i>	<i>Round</i>	<i>Rng</i>	<i>Damage</i>	<i>Pen</i>	<i>IFR</i>
152mm L/37	APHE	440	C23 B24	122C	24000
<i>Rld: 14</i>	CHEM	330	C3 (B30)	Nil	24000
	HE BB	330	C46 B45	16C	36500
	HE ER	330	C46 B45	16C	40300
	HEAT	330	C30 B30	175C	24000
	HEI	330	C24 B45	87C	24000
	ICM	Nil	B60	Grenade	24000
	ICM-DP	Nil	B60	Grenade*	24000
	ICM-DP BB	Nil	B60	Grenade*	36500
	ILLUM	Nil	(B2830)	Nil	24000
	Krasnopol CLGP	330	C46 B45	16C (TA)	25200
	MP-152 RAP HE	330	C46 B45	16C	36400
	SADARM	Nil	B30	Submunition*	24000