

Horizon Survey Craft

100 ton Spacecraft for Cepheus
Engine and the TL 9 Orbital setting

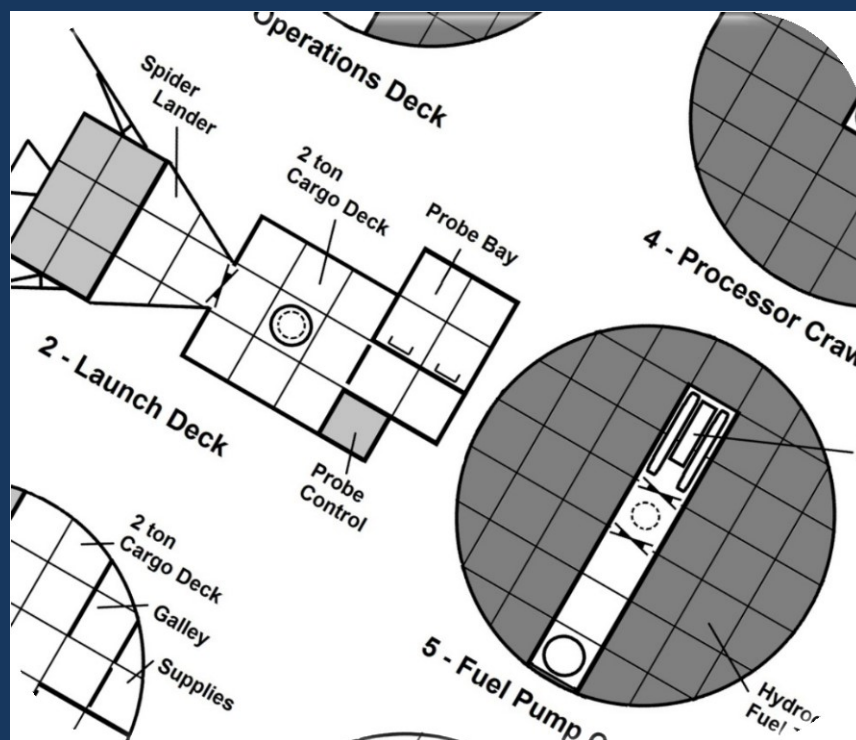

ZOZER

Horizon Survey Craft

Author

Paul Elliott

Interior Art

Paul Elliott

Publisher in PDF format

Zozer Games 2016

Visit Zozer Games at www.zozer.weebly.com

Find me on Facebook as Zozer Games

All rights reserved. Reproduction of this work by any means is expressly forbidden. This book is fully compatible with the Cepheus Engine roleplaying game, a Classic-Era Science Fiction 2D6-Based Open Gaming System. Cepheus Engine and Samardan Press are the trademarks of Jason "Flynn" Kemp," and Zozer Games is in no way affiliated with either Jason "Flynn" Kemp or Samardan Press™.

Horizon Survey Craft details a TL 9 spacecraft powered by a fission reactor and a nuclear thermal rocket. It was designed using the rules in Zozer Games' setting book called [Orbital 2100](#). Find information about Orbital 2100 and its roots in Traveller here at www.paulelliottbooks.com.

Orbital is a science fiction role-playing setting that makes use of the Cepheus Engine and other popular 2D6 SF rules with an overall Tech Level of 9 (but with the notable absence of gravitics, jump drive and anything related to psionics). Spacecraft use nuclear thermal rockets, fission powerplants and spin capsules in order to simulate on-board gravity. The world of **Orbital** describes a universe where humans have colonised the solar system but no further; where a Cold War rages and the people of Luna are engaged in a desperate political race against the Earth Union for domination of the solar system. Humanity has spread throughout the solar system, discovered life on several worlds, and confirmed the existence of intelligent life beyond our own little piece of real estate.

Yet even through all of these advances human kind remains largely unchanged. **Orbital** is a setting that is familiar, believable, and exotic. It focuses on exploration and adventure, and although science and technology have created a multitude of wonders, humans remain humans.

SPECIFICATIONS

Reiner Gama DRV Horizon

Using a 100 ton self-sealing hull, the Horizon is a light scientific research and reconnaissance craft. It has nuclear thermal rocket-A and powerplant-A giving a delta-V of 65 km/s. Fuel tankage of 40 tons allows for two trips at full thrust, and 1 ton of fuel processors is fitted. Adjacent to the bridge is a Model/1 computer and a basic civilian sensor suite. There are two double-cabins for the crew, a laboratory, and a 4-man emergency low berth unit for emergency situations. The Horizon has no spin capability; all interior areas are in zero-G. The vehicle has a single hardpoint with a double turret fitted. No weapons are installed. There are 5 science probes on-board with a launching station, as well as 5 tons of mining drones, used to bring ice aboard for fuel reprocessing. Carried craft is a small 5 ton Spider light lander used for surface missions. Overall cargo capacity is 4 tons. The craft includes a flare damper.

The Horizon requires a crew of four: pilot-commander, navigator, engineer and science specialist. The vehicle costs MCr 39.16 and takes 10 months to build.

Spider Light Lander (LL): The Spider is a lander used as an excursion craft by some DSVs. A lander is unstreamlined, and designed to drop from orbit to land passengers or cargo onto a moon with atmosphere 0 or 1. It requires landing suspension and resembles the small Apollo LEM. Using a 5-ton hull, the light lander is capable of 2 burns, carries 0.5 tons of fuel and has a crew of two. It is fitted with landing suspension and chemical batteries that provide 80 days of power. The craft can carry 1.17 tons of cargo which can be customized instead to carry two passenger couches. It costs MCr4.84.

DEVELOPMENT

The Horizon DRV was designed and built back in the 2070s by Reiner Gama to fulfil a need by the Lunar government. Expansion and colonisation of the solar system was accelerating and Luna found itself in competition with the Earth Union. This was a 'rush for the planets' and Luna didn't want to be left behind. What it needed was a type of low cost survey vehicle that it could manufacture in large numbers and which it could turn to other uses as needed. While the Earth Union was building 400 ton Surveyors for detailed surveys of possible mining and colony sites,

Luna was forced to respond with the Reiner Gama Horizon, a quarter of the size and only a sixth of the cost of the sophisticated Surveyor.

The stated mission of the developers was to create a 'light scientific and reconnaissance craft' and in this respect the Horizon proved perfectly suited, able to take a small crew anywhere within the solar system to take samples from asteroids, photograph possible colony landing sites, intercept comets and so on. With so many available it seemed only natural that the sensors aboard the Horizons would inevitably turned towards Earth Union installations and vehicles. In the same way that some Russian trawlers in the Cold War were actually spy ships, Horizons were renowned within the Union military for turning up when least expected, and when least wanted. Officially they are on some minor scientific mission, but the Union forces understand well enough their true mission ...

EXTERNAL APPEARANCE

Unusually, the Horizon has no spin capability and the interior is therefore a zero-G environment. It is laid out as a cylinder divided into four main sections, the aft and longest section is the propulsion compartment, three decks in length, housing the fuel tanks, reactor and nuclear thermal rocket. Two radiator panels are mounted on the hull here, spreading out like rectangular wings. Forward of this is the habitation compartment, covered with reflective Mylar. Forward of the hab section are more two compartments, first the launch deck with a docked Spider lander, science probes and cargo space; then at the forward end of the spacecraft, the operations deck. Here the flight deck is located, along with two airlocks, emergency low berths and a double turret; it forms the nerve centre of the vehicle.

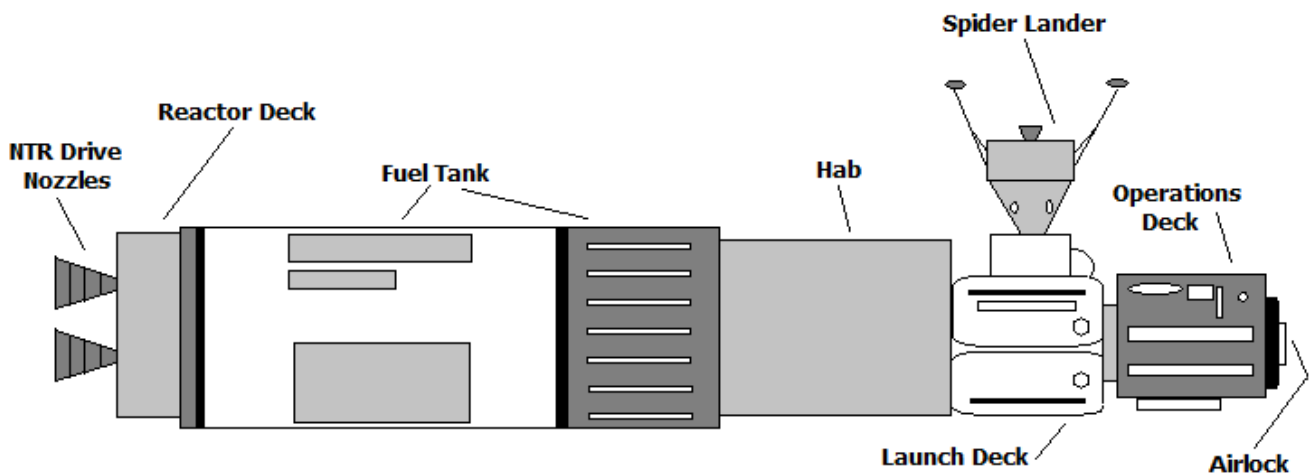

DECKPLANS

Reiner Gama DRV Horizon

□ 1.5m square

F Fresher

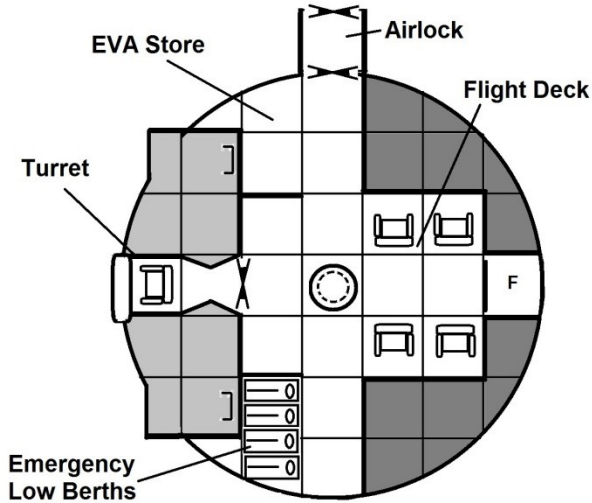

1 - Operations Deck

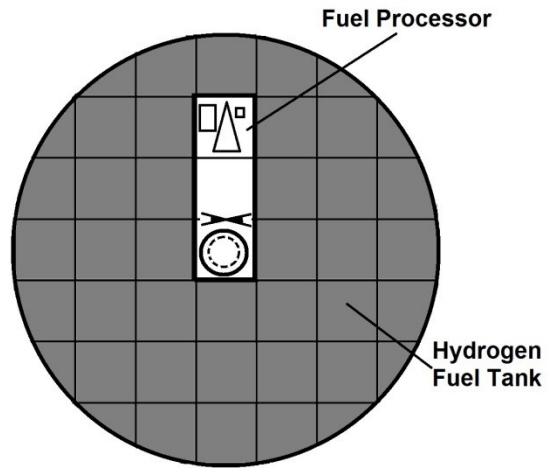

4 - Processor Crawlway

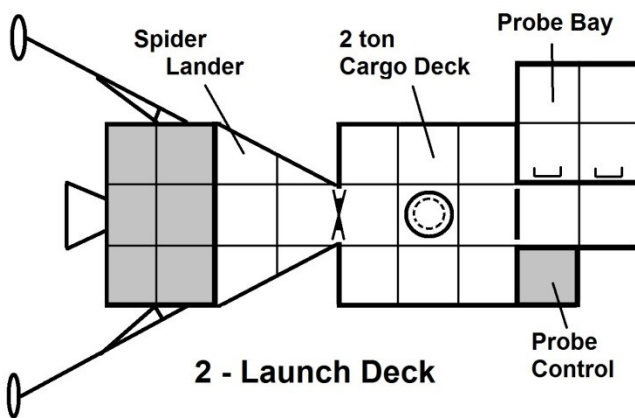

2 - Launch Deck

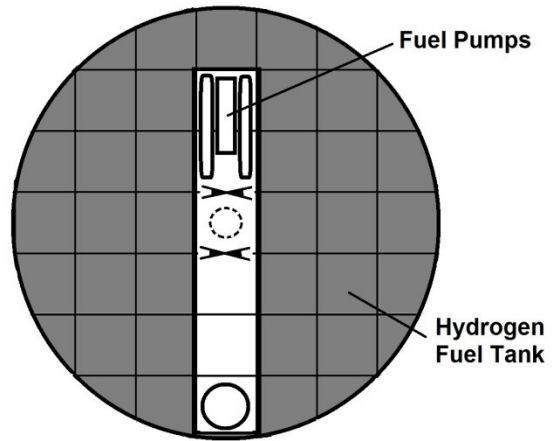

5 - Fuel Pump Crawlway

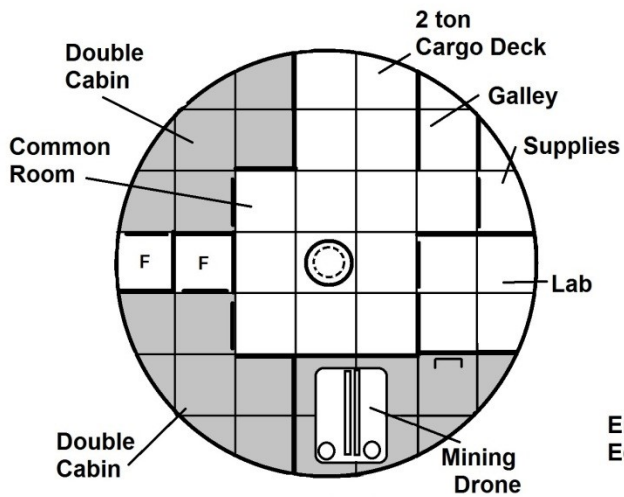

3 - Hab Deck

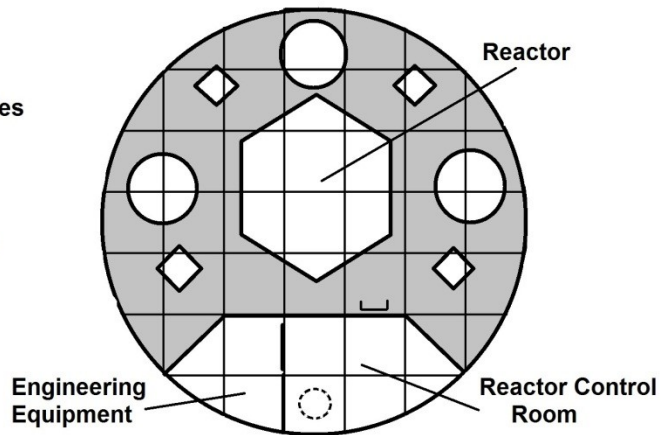

6 - Reactor Deck

TOUR

Let us explore the Horizon from the perspective of a crewman, use the deckplans included in this book to help you navigate the interior of the spacecraft. Our DRV, the Red Shift, is docked at a spin gravity station and Dmitri, the command-pilot, is going aboard to conduct a routine check. Since the docking port is at the very nose of the Horizon, Dmitri pulls himself through the airlock to find himself floating down into the flight deck, a tunnel continues below him right through the centre of the craft passing through all six decks, but the pilot stops here. Two pairs of seats, back to back form the cockpit, beyond is a fresher. The command-pilot and co-pilot sit next to each other, the flight engineer and mission specialist back to back, behind them. Looking around him, Dmitri sees he is in an open area used by the crew as a rest area, gym and lounge. With his back to the seats of the cockpit he looks ahead at the pressure door to the turret, on many Horizons this turret is not armed and instead is used as a scientific monitoring station. To the left of the pressure door are four emergency cryogenic berths. To the right a place for five hardsuits (one for each crewman and one spare) and various EVA tools. In the far right wall next to the spacesuits is the main airlock which can be used for EVAs, or emergency evacuation, even when the Red Shift is docked at a station.



Dmitri drifts into the cockpit area to check the power and life support readings, much of the life support machinery, along with computer and sensor equipment lies behind the panelling of the cockpit on this deck. Happy that everything is OK, the pilot kicks over to the hatch leading to the next level, and drifts out onto the launch dock. He emerges into a cargo area, Cargo Transfer Bags are stored in ceiling and wall racks, large cargoes are strapped to the floor all around him. Much of it is food and other supplies for the crew's survival. He faces a pressure door that leads to the Spider landing craft, the vehicle used by the Red Shift's crew to land on moons and asteroids, to conduct surface surveys or access colony worlds. The Spider is powered down, it will take at least 2 hours to prepare the lander for undocking and flight. A skilled individual might be able to do this much faster in an emergency.

Launching the Lander: Pilot, Intelligence, 1-6 hours, Average (0). Reduce time to 10-60 mins (Difficult -2); reduce time to 1-6 mins (Very Difficult -4).

Turning around, Dmitri passes through a sliding door to enter the probe bay. In this small area are the controls and monitoring station for scientific probe drones on the right, with panels to the left allowing access to the launch tubes of the probes should the drones require maintenance or replacement (they are considered expendable).

Floating back onto the cargo deck, the pilot of the Red Shift descends once again to emerge into the rec area of the vehicle. This area holds a large TV screen, a table and an area for additional supplies and equipment loaded into CBTs and stored against the curved hull. There are four doorways, usually open, leading off from the rec area. Two of these are double bunk rooms for the crew, each with wall mounted sleeping bags and privacy curtain, shared fresher, storage lockers for clothing and personal items, 'space' for gym equipment, decoration, plants etc. The third doorway leads into a laboratory where soil, rock or other samples can be properly studied. On those Horizons re-tasked for other purposes, the lab is often configured for another purpose. The final doorway leads into the galley, complete with refrigerator, freezer, microwave and food prep

area. A maintenance hatch on the hab deck allows access to the mining drone that is mounted within a hanger, this hanger has an external door allowing the drone access to space.

Now the command-pilot descends into the drive compartment. He passes a pressure door that gives access to the fuel processor, the tunnel continues to arrive at a dead end. In front of him a pressure door leading to the fuel pumps, these squirt high pressure cryogenic liquid hydrogen into the reactor. Behind him is a final pressure door that opens into a short corridor, he is on his way to the reactor room. Floating to the end of the 5m corridor, he descends through a locked hatch into the reactor control room. Windows provide a view into the reactor, banks of controls are on hand to control every aspect of the reactor and the power distribution system. The reactor runs the electrical power systems of each Horizon, and serves the dual purpose of superheating liquid hydrogen to provide thrust during acceleration and deceleration burns.

A doorway leads to a small store of engineering tools and racks of spare parts that allow routine maintenance to be carried out. Once the power systems have been checked, Dmitri returns through the locked hatch, along the short corridor to the base of the tunnel and then kicks off to float all the way up into the operations deck and the docking lock that he first gained access to through. His tour of the Red Shift is over.

VARIANTS

Military Reconnaissance better sensors

Light Attack Craft carrying a star sabre interceptor

Rescue vehicle, modified mining drone, 4 ton lab is a 16 e low berths, Orion pod, mission medic

CREW OF THE RED SHIFT

Captain Dmitri Solokov (command-pilot) 497A86 Age 42 6 terms Cr 3,000
Vacc Suit 1, Pilot 2, Zero-G 2, Astrophysics 2, Computer 3, Engineer 1, Navigation 1, Comms 1

Solokov trained as a commercial airline pilot before retraining as a spacer. He took to orbit along with his wife, but in an accident in Mars orbit, his wife was killed. Solokov blamed himself, though in fact the mistake that killed her was the fault of his best friend, Ray Friedman. Solokov doesn't know this, but Ray keeps the secret that haunts him. ESDA hired both men fifteen years ago and they have both worked on Horizons DSVs ever since. Dmitri is talkative and confident, but can lapse into sullen moods. Always unshaven, he wears a baseball cap with the Red Shift mission patch at the front.

Executive Officer Raymond Friedman (pilot) 558777 Age 38 5 terms Cr 1,000
Vacc Suit 2, Pilot 1, Comms 1, Persuade 1, Sensors 3, Navigation 2, Computer 1, Biology 1

Friedman has known the captain for years, and they have a shared history (see Solokov). Friedman is a thin, blonde spacer with a goatee beard. He is a member of the Planetary Reproductionists, a scientific group that believe humans are the agency for planet's to reproduce via terraforming and colonisation. It's a fringe theory and Friedman often passes information and data to his colleagues. Raymond is light-hearted and easy-going, a real optimist.

Senior Flight Officer Marina Shu (flight engineer) 858998 Age 30 3 terms Cr 1,000
Vacc Suit 1, Pilot 1, Engineer 2, Zero-G 2, Mechanics 2

Marina and the rest of her previous crew was captured by the White Tigers in 2095 when that terror group (allied with the Lunars) tried to launch a coup on Iapetus, a moon of Saturn. The crew were held hostage and finally ransomed, but Marina has developed a hatred for the Lunars that persists to this day. She was debriefed by the Earth Union security forces and continues to feed them information. In truth she is terrified of being captured by the Lunars again. Marina is stubborn, her brown hair is pulled severely back into a pony-tail and sleeves are perpetually rolled up.

Flight Officer Mark Martinez (science officer) 6897A5 Age 34 4 terms Cr 2,000
Vacc Suit 2, Geomorphology-1, Glaciology-2, Survival (Polar) 1, Pilot 1

Mark is the crew's science officer, and he also pilots the lander when required. He is always keen to get his hands dirty, land, dig down and recover samples. His geology training was conducted at the University of Adrienne, giving him a love of Mars and a great sympathy with the Greens on that world. Humans can achieve great things if given the tools and the resources. Mark is flippant and terse, and he does not waste words. He has Latin features, short, wiry black hair and tattoos on his forearms and chest.

Legal Information

The Cepheus Engine Compatibility-Statement License (CSL)

You must state on the first page where you mention Cepheus Engine that "Cepheus Engine and Samardan Press are the trademarks of Jason "Flynn" Kemp," and that you are not affiliated with Jason "Flynn" Kemp or Samardan Press™.

If you're using the license to commit legal fraud, you forfeit the right to continue using the license: specifically, if you are claiming compatibility with the rules of Cepheus Engine, the claim must not constitute legal fraud, or fraud in the inducement, under the laws of the State of Texas. Note that this requirement is almost impossible to violate unintentionally—it's largely intended to keep me out of trouble, not to restrict legitimate statements of compatibility.

You must comply with the terms of the OGL if the terms apply.

Your cover must include the words "House Rules" or "Variant Rules" or "Alternate Cepheus Engine Universe" near the title if the document is a full, free-standing game that includes modifications. Feel free to contact the author if you wish to use a different form of disclaimer.

Selling a full version of this game with your house rules incorporated into it is perfectly permissible, but you may not sell an effectively unchanged copy of the rules for money.

If your document is a private house rules document, not being sold for profit or general use, you may scan and use artwork (including the cover) from the printed version, published in print under the title of **Cepheus Engine Core Rules**, provided that the cover contains the words "House Rules," near the title, and that the artists are appropriately credited.

Your rights under this CSL cannot be revoked, and are perpetual, unless you breach the terms of the license, in which case your rights terminate.

If you comply with the above, you may state that your resource is "for use with the Cepheus Engine Core Rules", "compatible with the core rules of Cepheus Engine" or "with the Cepheus Engine Core Rules." If you have questions about the license, feel free to contact the author.

OPEN GAME LICENSE Version 1.0a

The following text is the property of Wizards of the Coast, Inc. and is Copyright 2000 Wizards of the Coast, Inc ('Wizards'). All Rights Reserved. 1. Definitions: (a)'Contributors' means the copyright and/or trademark owners who have contributed Open Game Content; (b)'Derivative Material' means copyrighted material including derivative works and translations (including into other computer languages), potation, modification, correction, addition, extension, upgrade, improvement, compilation, abridgment or other form in which an existing work may be recast, transformed or adapted; (c) 'Distribute' means to reproduce, license, rent, lease, sell, broadcast, publicly display, transmit or otherwise distribute; (d)'Open Game Content' means the game mechanic and includes the methods, procedures, processes and routines to the extent such content does not embody the Product Identity and is an enhancement over the prior art and any additional content clearly identified as Open Game Content by the Contributor, and means any work covered by this License, including translations and derivative works under copyright law, but specifically excludes Product Identity. (e) 'Product Identity' means product and product line names, logos and identifying marks including trade dress; artifacts; creatures characters; stories, storylines, plots, thematic elements, dialogue, incidents, language, artwork, symbols, designs, depictions, likenesses, formats, poses, concepts, themes and graphic, photographic and other visual or audio representations; names and descriptions of characters, spells, enchantments, personalities, teams, personas, likenesses and special abilities; places, locations, environments, creatures, equipment, magical or supernatural abilities or effects, logos, symbols, or graphic designs; and any other trademark or registered trademark clearly identified as Product identity by the owner of the Product Identity, and which specifically excludes the Open Game Content; (f) 'Trademark' means the logos, names, mark, sign, motto, designs that are used by a Contributor to identify itself or its products or the associated products contributed to the Open Game License by the Contributor (g) 'Use', 'Used' or 'Using' means to use, Distribute, copy, edit, format, modify, translate and otherwise create Derivative Material of Open Game Content. (h) 'You' or 'Your' means the licensee in terms of this agreement. 2. The License: This License applies to any Open Game Content that contains a notice indicating that the Open Game Content may only be Used under and in terms of this License. You must affix such a notice to any Open Game Content that you Use. No terms may be added to or subtracted from this License except as described by the License itself. No other terms or conditions may be applied to any Open Game Content distributed using this License.

3. Offer and Acceptance: By Using the Open Game Content You indicate Your acceptance of the terms of this License.
4. Grant and Consideration: In consideration for agreeing to use this License, the Contributors grant You a perpetual, worldwide, royalty-free, non-exclusive license with the exact terms of this License to Use, the Open Game Content.
5. Representation of Authority to Contribute: If You are contributing original material as Open Game Content, You represent that Your Contributions are Your original creation and/or You have sufficient rights to grant the rights conveyed by this License.
6. Notice of License Copyright: You must update the COPYRIGHT NOTICE portion of this License to include the exact text of the COPYRIGHT NOTICE of any Open Game Content You are copying, modifying or distributing, and You must add the title, the copyright date, and the copyright holder's name to the COPYRIGHT NOTICE of any original Open Game Content you Distribute.
7. Use of Product Identity: You agree not to Use any Product Identity, including as an indication as to compatibility, except as expressly licensed in another, independent Agreement with the owner of each element of that Product Identity. You agree not to indicate compatibility or co-adaptability with any Trademark or Registered Trademark in conjunction with a work containing Open Game Content except as expressly licensed in another, independent Agreement with the owner of such Trademark or Registered Trademark. The use of any Product Identity in Open Game Content does not constitute a challenge to the ownership of that Product Identity. The owner of any Product Identity used in Open Game Content shall retain all rights, title and interest in and to that Product Identity.
8. Identification: If you distribute Open Game Content You must clearly indicate which portions of the work that you are distributing are Open Game Content.
9. Updating the License: Wizards or its designated Agents may publish updated versions of this License. You may use any authorised version of this License to copy, modify and distribute any Open Game Content originally distributed under any version of this License.
10. Copy of this License: You MUST include a copy of this License with every copy of the Open Game Content You Distribute.
11. Use of Contributor Credits: You may not market or advertise the Open Game Content using the name of any Contributor unless You have written permission from the Contributor to do so.
12. Inability to Comply: If it is impossible for You to comply with any of the terms of this License with respect to some or all of the Open Game Content due to statute, judicial order, or governmental regulation then You may not Use any Open Game Material so affected.
13. Termination: This License will terminate automatically if You fail to comply with all terms herein and fail to cure such breach within 30 days of becoming aware of the breach. All sublicenses shall survive the termination of this License.
14. Reformation: If any provision of this License is held to be unenforceable, such provision shall be reformed only to the extent necessary to make it enforceable.
15. COPYRIGHT NOTICE
Open Game License v 1.0a Copyright 2000, Wizards of the Coast, Inc.
High Guard System Reference Document Copyright © 2008, Mongoose Publishing.
Mercenary System Reference Document Copyright © 2008, Mongoose Publishing.
Modern System Reference Document Copyright 2002-2004, Wizards of the Coast, Inc.; Authors Bill Slavicsek, Jeff Grubb, Rich Redman, Charles Ryan, Eric Cagle, David Noonan, Stan!, Christopher Perkins, Rodney Thompson, and JD Wiker, based on material by Jonathan Tweet, Monte Cook, Skip Williams, Richard Baker, Peter Adkison, Bruce R. Cordell, John Tynes, Andy Collins, and JD Wiker.
Swords & Wizardry Core Rules, Copyright 2008, Matthew J. Finch
System Reference Document, Copyright 2000, Wizards of the Coast, Inc.; Authors Jonathan Tweet, Monte Cook, Skip Williams, based on original material by E. Gary Gygax and Dave Arneson.
T20 - The Traveller's Handbook Copyright 2002, Quiklink Interactive, Inc. Traveller is a trademark of Far Future Enterprises and is used under license.
Traveller System Reference Document Copyright © 2008, Mongoose Publishing.
Traveller is © 2008 Mongoose Publishing. Traveller and related logos, character, names, and distinctive likenesses thereof are trademarks of Far Future Enterprises unless otherwise noted. All Rights Reserved. Mongoose Publishing Ltd Authorized User.
Cepheus Engine System Reference Document, Copyright © 2016 Samardan Press; Author Jason "Flynn" Kemp
16. The Horizon and its layout constitutes Product Identity, which is protected by copyright as identified in section 1. Copyright © 2016 Zozer Games; Author Paul Elliott.