

# TRAVELLER

SOLOMANI ADVENTURE 1:  
MYSTERIES ON ARCTURUS STATION



SCIENCE FICTION ADVENTURE IN THE FAR FUTURE



# TRAVELLER

## SOLOMANI ADVENTURE 1: MYSTERIES ON ARCTURUS STATION

### CREDITS

#### CLASSIC TRAVELLER

Marc Miller

Loren Wiseman, John Harshman, Frank Chadwick, Darryl Hany, Winston Hamilton, Tony Svajlenka, Scott Renner, Doug Poe, David MacDonald, Wayne Roth, Paul R. Banner.

Original Murder on Arcturus Station written by J. Andrew Keith

#### MONGOOSE TRAVELLER

##### Author

Seth Skorkowsky

##### Editor

Matthew Sprange

##### Layout

Morné Schaap, Sandrine Thirache

##### Illustrations

Quentin Soubrouillard (cover), Andoni Fernandez, Diego D. Diez, Maria Assinimova, Maia Anderson, Michael Leonard, Mark Graham

#### TRAVELLER INNER CIRCLE

Andrew James, Alan Welty, Colin Dunn, M. J. Dougherty, Rob Eaglestone, Sam Wissa, Joshua Bell, Maksim Smelchak

#### Special Thanks

Marc Miller, Loren Wiseman

#### Playtesters

Kayci Skorkowsky, Jorge Soto, Steven Foskett, Elizabeth Foskett, Matthew McCloud, James Sugrue, Rick Thomas, Pedro Moreno, Betty Tatum, Marsha White, and William 'Butterfly' Paprocki

### CONTENTS

INTRODUCTION	2
ARCTURUS	3
STATION THREE	4
ADVENTURE 1:	
THE HUNT FOR SABRE IV	6
ADVENTURE 2:	
MURDER ON ARCTURUS STATION	18
CHARACTERS AND OPPOSITION	49
LIBRARY DATA	61
CENTRAL SUPPLY CATALOGUE	62
HIGH GUARD: ARCTURUS STATION	66
PLAYER HANDOUTS	72



*Traveller* ©2021 Mongoose Publishing. All rights reserved. Reproduction of this work by any means without the written permission of the publisher is expressly forbidden. All significant characters, names, places, items, art and text herein are copyrighted by Mongoose Publishing.

This game product contains no Open Game Content. No portion of this work may be reproduced in any form without written permission. To learn more about the Open Game License, please go to [www.mongoosepublishing.com](http://www.mongoosepublishing.com).

This material is protected under the copyright laws of the United Kingdom and of the United States. This product is a work of fiction. Any similarity to actual people, organisations, places or events is purely coincidental.

Traveller is a trademark of Far Future Enterprises and is used under licence.

Printed in China

# T R A V E L L E R INTRODUCTION

*Mysteries on Arcturus Station* consists of two investigative adventures where the Travellers must solve a crime. These adventures may be played individually, or together, with one leading directly into the other. As the title suggests, both adventures are set on board a space station in the Arcturus system, although they could easily be transplanted to any major asteroid belt.

The Arcturus Belt is located in the Solomani Rim sector. An unimportant system by most standards, it has attracted a number of mineral exploitation firms, which have established large-scale mining operations among the asteroids; the bulk of the system's small population is made up of miners employed by these firms.

In the first adventure, *The Hunt for Sabre IV*, the Travellers are hired by a mining company to locate a stolen ore carrier. This is followed by the second adventure, *Murder on Arcturus Station*, where the Travellers must solve a murder that they are suspected of committing.

Any group of Travellers will be suitable for these adventures. They are not required to have access to their own starship. Investigative and social skills are useful but the events of the adventures can be handled in a variety of different ways.

Referees only require the *Traveller Core Rulebook* to run these adventures.

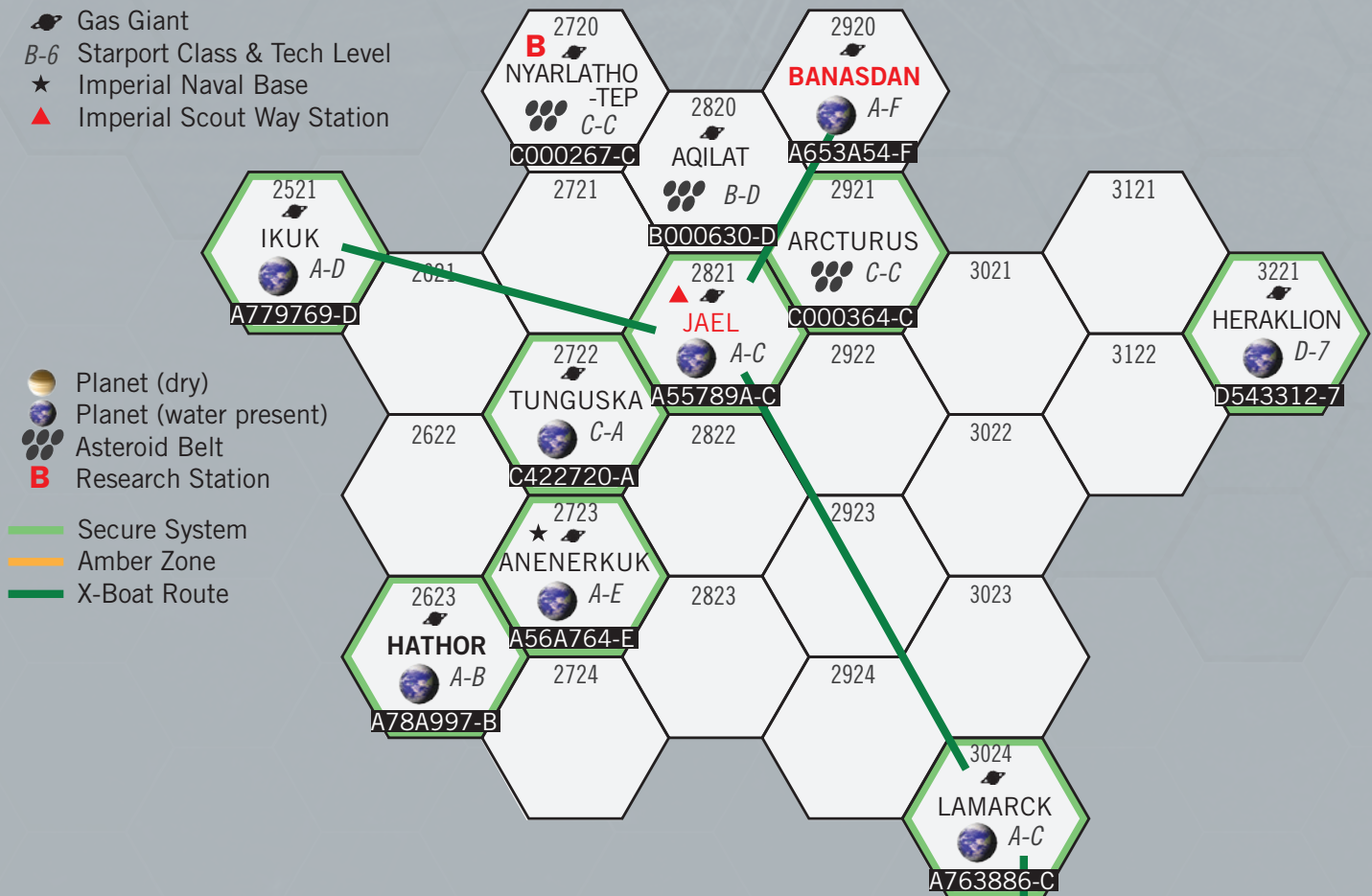



# ARCTURUS

The Arcturus Belt (C000364-F) is a comparative backwater system of the Solomani Rim. The system is of little importance, with no better than Class C starport facilities and a small (about 8,000) population. Most of these are miners employed by one of the mineral exploitation firms operating in the belt.

Mining licenses are granted by representatives of Banasdan government, based at Wainwright Starport. For the most part, mining licenses are held by large corporations; smaller companies and individuals have found it extremely expensive to participate in belt mining operations – a major point of contention that has received considerable attention in recent months.

Arcturus Belt has been roughly divided into four quadrants, each defined loosely by the location of an administrative station. There are three such stations, plus Wainwright Starport. Variations in orbital paths between these four bodies cause some shifting in the definition and nature of each quadrant but the changes are so gradual as to be completely unimportant during the period of these adventures.

Each station is operated under the auspices of the Banasdan government. They serve as centres of supply, administration and recreation open to miners from each of the companies working in the quadrant.

Stations are run by a station manager and a small administrative staff (total station personnel, including staff, technicians and support people, numbers about 75 in each station).

Miners being what they are, a certain degree of enforcement is necessary to ensure 'recreation' is kept reasonably well controlled. Because there are insufficient numbers of Banasdan representatives in the system, local enforcement is largely handled by the various companies at each station. Companies are given jurisdiction over their own employees, with the understanding this jurisdiction is not to be abused, subject to revocation of the corporate mining license.

Four patrol cruisers and a detachment of Banasdan Port Authority Police are stationed at Wainwright Starport. Here they maintain general order, enforce customs and immigration restrictions and act as a mobile backup in case of problems that cannot be handled through normal channels. In the past century, such problems have only arisen three times – the Station Two Riots of 1061, the piratical activities of Jon Fastern in 1078 and the sabotage carried out by independent miners on corporate property belonging to Lamarck Minerals and Triple-G Resources, LIC, in 1098. In each case, the Wainwright Starport police detachment was more than adequate to handle the problems as they arose.

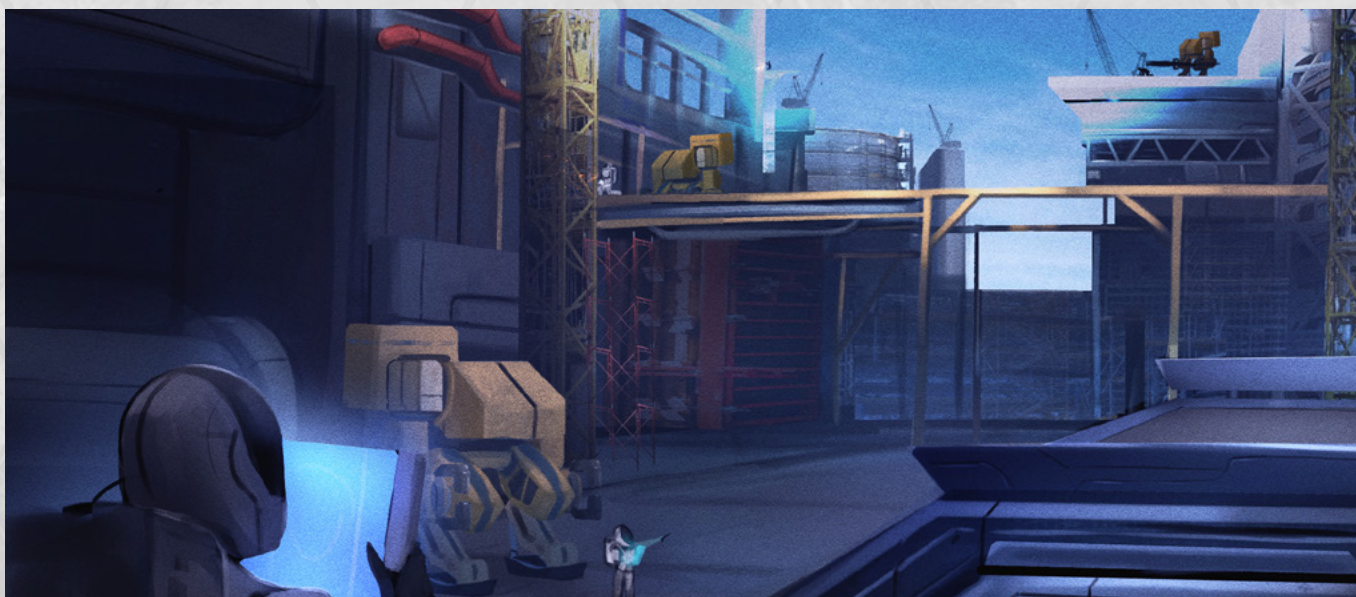



# C H A P T E R - 2

# STATION THREE

Arcturus Station Three serves as the base of operations for Lamarck Minerals' mining operation. While some corporate offices make their home at Wainwright Starport, the bulk of the employees and mining craft use Station Three as their hub. Mining crews dock there between deployments for ship maintenance and R&R. Many enjoy use of the retail stores, restaurants and entertainment available, while staying in staterooms far more comfortable than those aboard their ships. A team of dock crew employees inspect and maintain Lamarck Minerals' ships.

The manager of Station Three is Marja Aguilar, an employee of the Banasdan government who regularly works with Lamarck Minerals and their president Ringiil Urshukaan. Her job is to oversee the small staff of station employees, maintain order and keep their client happy. It is not an easy job. At any time, Station Three houses 70 staff and 150 guests.

## STAYING AT STATION THREE

As with all Lamarck Minerals employees, the Travellers are expected to pay for their own rooms at Arcturus Station. Basic staterooms are Cr150 a night and can house up to four guests (although not very comfortably). Deluxe rooms are Cr350 a night and include a separate living, bedroom and kitchenette. These comfortably house four but can accommodate up to eight guests if they really like each other.

## SECURITY CAMERAS

As with any large space station, security cameras monitor all public areas and passages. Footage is monitored at security stations on each level and can be accessed at any terminal connected to the network (providing the user has the authority clearance). As per Banasdan Law, there are no cameras in staterooms or lavatories.

The cameras on the Middle Deck (staterooms) have been broken. Inquiring Travellers are informed the damage recently occurred after a rumour Lamarck Minerals was spying on its employees during their time off. Marja

Aguilar explains that while the station is owned and operated by the Banasdan government, the security personnel are employed by Lamarck Minerals, LIC. Replacement cameras have been ordered but are not expected for at least two months. Regardless, there is no security footage available for the Middle Deck.

**Referee Note:** Alternatively, some cameras on the Middle Deck might still function, providing further clues or misdirection. The camera directly outside a crime scene might be damaged but deeper searching of the deck's footage could provide a brief glimpse of a suspect as they cross a distant intersection. A criminal might destroy or disable a camera before or after a crime, providing a clue that the crime was premeditated or that the perpetrator possesses the necessary skills to hack a camera. Referees should determine in advance where camera coverage has been compromised.

## THUMBPRINT LOCKS

A common security device found throughout the Imperium. Staterooms on Station Three are all opened via thumbprint locks; guests must enter their thumbprint when they register. For disabled, augmented or alien guests who lack thumbprints, rental and keypad options are also available. Using an elevator to access the various floors also requires the appropriate thumbprint, card, scan or code, although only a single occupant of the elevator needs to enter the authorisation. The locks log the times and data when used, although stateroom doors opened from the inside do not require unlocking, so no data is logged.

These can be opened with a Difficult (10+) Electronics (computers) check (1D minutes, INT).

## DISPOSAL CHUTE

Disposal chutes are the general method of waste disposal in Arcturus Station and found in most public corridors and in all sanitary closets in the facility. Trash fed into the disposal chute is stored temporarily



until, at regularly scheduled intervals, all chutes empty into a large recycling room. Here, garbage is sorted by automated machines, reduced to its basic constituents and placed back into the station's store of raw materials.

Intervals between emptying chutes are employed to clean the recycling room and also allow individuals a chance to change their minds about disposing of some items. Anything thrown in a disposal chute is destroyed within 2D hours if not retrieved in time.

## DELIVERY TUBE

Similar to the pneumatic tube technology of centuries past, delivery tubes transport items between various parts of the station. Most often, this is food or other goods from stores and restaurants delivered to staterooms but guests may also transfer items between rooms. Items passing through the tube system are kept level with the station's gravity, meaning liquids are less-inclined to spill (though lids are still required). Deliveries can be no larger than 21 centimetres wide and three Kilograms.





# ADVENTURE 1: THE HUNT FOR SABRE IV

The Travellers are hired by the president of a mining company to locate a stolen ore carrier before it can escape the system. When their prime suspect comes up as a framed murder victim, the Travellers must uncover who the conspirators are, locate the ship and figure out how to seize it from an armed and desperate crew.

Travellers do not require their own ship for this adventure. If they have one, it is docked at Wainwright Starport and unavailable to use. While most of the clues can be discovered through a variety of different means, the most helpful skills will be Investigate, Carouse, Persuade and Electronics (computers). There may be very little combat but depending on what actions the Travellers take, and how other characters respond, there could be more.

## HOW TO RUN THIS ADVENTURE

This is an investigative adventure. From the time they are hired, the Travellers have 10 days to locate the missing ore carrier and prevent its escape. The Travellers are unaware of the deadline but they do know there is not much time. There is no particular order in which they can complete the adventure and some avenues presented in the following pages might not be used.

Roleplaying of character personalities is essential in mystery games. The Travellers should not only interact with the characters presented in this adventure but with anyone in the station. Referees should not only familiarise themselves with the cast included here but be prepared to improvise any number of other personalities the Travellers may encounter.

Time is an important aspect to this adventure. While the Travellers have several days to accomplish their mission, various tasks can take hours to perform. Conducting interviews, gathering rumours or investigating crime scenes requires significant time and should not be resolved with a few dice rolls and no passage of in-game time.

As with all scenarios, referees should read and be familiar with the entire adventure prior to running it and be ready to make changes or improvise depending on what actions the Travellers take. Failure to locate the ship in time is a definite possibility. In the end, the Travellers will fail to capture the ringleader or learn the identity of the mastermind behind the plot. While this may seem to be a minor detail compared to the ore carrier's recovery, their patron has a different opinion.

*The Hunt for Sabre IV* is designed as a prequel to *Murder on Arcturus Station*. While referees do not need to read or use one in order to run the other, they are designed to complement one another. Several of the characters and events in this adventure are referenced in *Murder on Arcturus Station* and this is intended to familiarise the Travellers with not only a few of the characters but also locations and equipment found there.

## BACKSTORY

Lamarck Minerals, LIC, has a poor reputation among the miners of the Arcturus Belt. Under the direction of company president Ringiil Urshukaan, employees have endured longer deployments, shorter rest periods, impossible quotas, faulty equipment, smaller crews and less pay while Lamarck Minerals gloats about increased profits. While most employees fight these complaints through their fledgling union, many others have resorted to vandalism, sabotage and theft. The majority of these are minor annoyances. However, one group of Lamarck Minerals employees have much larger plans to get even with the company while also getting rich.

Hart Fonroe has worked as a mining boat pilot for seven years. He took an active role in trying to establish a union after Ringiil Urshukaan was made company president. When mining boat L4-M7 was lost in an accident last year, Hart stopped trying to fight Lamarck Minerals the legal way. He knew the four-person crew and, like many Lamarck Minerals employees, blamed the accident on worn-out parts and not on pilot error, as the company claimed.



Ten months ago, Hart was contacted by a person calling themselves Omega. Omega proposed that if Hart and a trustworthy crew could steal a fully loaded Sabre ore carrier, not only would the revenue from the 1,500-ton ship and its cargo set them up for life but it would deal a serious blow to Lamarck Minerals.

Under Omega's guidance, Hart spent months gathering a crew of like-minded employees and putting the plan together. All of his co-conspirators are aware of Omega's existence as their patron but only Hart knows Omega's identity. Because few miners are trained in astrogation, Lance Gimsa began certification training as an astrogator. Finally, everything was in place.

After finishing a mining deployment, the crew stayed on Arcturus Station Three for their contractually-required two-week break. The plan was that when the ore hauler Sabre IV arrived for its fuel, maintenance and inventory inspection, the thieves would lure Captain Hummit Madsen to a room, interrogate him for the access codes and murder him. The next day, when the team would be scheduled to leave for their normal three-week shift, they would take both the ore carrier and their mining boat GT-56. Once away from the station, they would dock the vessels and jump away with both hauler and mining boat.

Unfortunately, things did not go as planned. Shortly after arriving at Arcturus Station Three, Lance Gimsa was called back early to work for a two-week assignment aboard the BT-23 (a loophole in the worker contracts which Lamarck Minerals regularly exploits). The shift would take him from the station during the time the Sabre IV was docked. After considering he not go or simply quit his job, it was decided that to avoid suspicion or unwanted attention, Lance should go on the assignment. The rest of the crew would carry out the plan as normal but instead of immediately jumping away after the theft, they would disable the Sabre IV's transponder and hide the ore carrier out in the belt. Once Lance Gimsa returned from his job, he and Dyrrol Mollik would steal a mining boat, rendezvous with the Sabre IV and jump away.

It has been three days since Sabre IV was stolen and Lamarck Minerals has only now learned of it. Captain Hummit Madsen's security codes were used to access the ship and release the docking clamp. He is now the prime suspect. The thieves' plan is right on schedule. They only thing they have not anticipated is the Travellers.

## TIMELINE

These are events of the adventure leading to when the criminals escape. Hopefully, once the Travellers become involved on Day 15, the events afterward change to their favour.

**Day 1:** Hart Fonroe and his team of conspirators arrive at Arcturus Station Three to begin a two-week rest break. **1**

**Day 6:** Lance Gimsa leaves on early deployment with the BT-23.

**Day 10:** Sabre IV and her crew arrive for fuel, maintenance and inventory inspection before heading out in five days. **10**

**Day 12:** Captain Hummit Madsen drinks with Fonroe and his associates. He is drugged, escorted to his stateroom, interrogated and murdered.

**Day 13:** Sabre IV and mining craft GT-56 leave Station Three. Everything appeared normal to the station crew. **13**

**Day 15:** Madsen's crew shows up to find Sabre IV gone. Travellers arrive at Station Three. Urshukaan leaves Station Three.

**Day 16:** The mutilated body of Captain Hummit Madsen is discovered in his room by cleaning staff. **16**

**Day 18:** Mining craft GT-56 is discovered adrift and abandoned.

**Day 20:** Lance Gimsa returns to Station Three from his mining expedition. **20**

**Day 21:** Lance Gimsa and Dyrrol Mollik take a mining craft and head out to Sabre IV.

**Day 22:** Urshukaan returns to Station Three and demands a progress update from the Travellers. **22**

**Day 24:** Lance Gimsa and Dyrrol Mollik arrive at Sabre IV. Urshukaan departs Station Three.

**Day 25:** Sabre IV jumps away and the criminals escape. **25**



## DRAMATIS PERSONAE

The following is a brief summary of the major characters and their roles. For characteristics and personality profiles, see Characters and Opposition on page 49.

### The Ally

**Marja Aguilar** – Manager for Arcturus Station Three

### The Patron

**Ringiil Urshukaan** – President of Lamarck Minerals, LIC.

**Martin Lukargik** – Urshukaan's personal assistant

**Eayukheal** – Urshukaan's Aslan security consultant

**Enli Alnasr** – Urshukaan's bodyguard

### The Murder Victim

**Hummit Madson** – Captain of the Sabre IV

### The Sabre IV Crew

**Xain Fernis** – Engineer

**Yessid Sast** – Engineer

**Emily Dinok** – Sensor operator

**Aran Bupeel** – Vargr co-pilot and astrogator

### The Criminals

**Hart Fonroe** – Captain of the mining craft GT-56

**Kari Gimsa** – Sensor operator of the GT-56. Sister of Lance Gimsa

**Boris Davlin** – Vargr engineer of the GT-56

**Allie Timmon** – Pilot and turret operator of the GT-56

**Dyrrol Mollik** – Vargr dock crew at Station Three

**Lance Gimsa** – Turret operator of the mining craft BT-23

## INTRODUCING THE TRAVELLERS

The Travellers have arrived at Wainwright Starport in the Arcturus Belt. The reason for their visit, whether delivering goods, simply looking for work or specifically called in for this job, is up to the referee. Shortly after their arrival, they are contacted by Martin Lukargik, personal assistant to Ringiil Urshukaan, president of Lamarck Minerals, LIC. Mister Urshukaan wishes to meet with them to discuss a potential job. Lukargik does not share the specifics but if pressed he discloses it is in relation to uncovering a group of dissident employees responsible for sabotaging company property and his employer is willing to pay a generous sum for their help in the matter. Urshukaan is currently located on Arcturus Station Three and requests they meet him there. If they agree to meet, Lukargik books the Travellers passage on the next intrasystem liner headed for Station Three.

**Referee Note:** To add a personal connection, Station Manager Marja Aguilar might be a Contact or Ally to one of the Travellers. Alternatively, switch her to being one of the Traveller's existing Contacts or Allies. Marja heard the Travellers were in the system and recommended them for the job.

Because each station's limited docking space is reserved for government and company vehicles, the Travellers cannot bring their own ship to Station Three. A weekly liner leaves Wainwright Station in D3 days and takes three days to reach Station Three. During this voyage, the Travellers may hear rumours of unrest among Lamarck Minerals employees.

An hour before the liner arrives at Station Three, the Travellers are contacted by Martin Lukargik, telling them events have escalated and they are to report directly to Ringiil Urshukaan's office when they land.

## ARRIVING AT STATION THREE

The station port buzzes with activity as the Travellers step off the liner. It smells of ozone, spilt lubricant and unwashed bodies. They are hurried through processing and escorted to Ringiil Urshukaan's suite on the Middle Deck.

### Meeting Urshukaan

Raised voices greet them as the Travellers arrive at Ringiil Urshukaan's suite. It is clean and organised with military precision. A few pictures of their prospective employer decorate the walls – a young officer in an Imperial Army uniform, an older, suited man shaking hands with political leaders. They enter his office as Urshukaan is yelling at an Aslan (Eayukheal) for not stopping this crime before it happened. The Aslan stands stoic, not defending himself from the verbal assault. A broad-chested bodyguard (Enli Alnasr) stands near the wall, his gaze never leaving the Travellers. Marja Aguilar is also present.

Once finished scolding his security consultant, Urshukaan turns his attention to the Travellers. He huffs that had they arrived sooner, they might have prevented this theft. If the Travellers point out that the time it took for them to arrive was outside of their control, Urshukaan merely nods, mumbles that it no longer matters but does not apologise.





## The Job

Ringiil Urshukaan tells the Travellers that only two hours ago it was discovered the ore carrier Sabre IV was stolen from the station's docking bay with a full cargo load (890 tons). The ship's crew arrived at the dock, as scheduled, only to learn that Captain Hummit Madson had taken it out on a 'routine inspection flight' two days ago and never returned. Docking bay security footage shows three individuals entering the ship. The faces of all three are hidden but Captain Madsen's uniform is clearly visible and his codes were used to release the station's docking clamp. The other two culprits are unknown but one appears to be a Vargr.

Station sensors are unable to locate the Sabre IV and its last known transponder ping was 28 hours ago, about five million kilometres from the station. The ship is jump-2 capable and may have already left the system.

'*Someone knows something,*' Urshukaan says. In the last year, Lamarck Minerals has suffered a sharp rise in sabotages. So far, those have been limited to only broken fuel lines, disabled drive systems and other expensive but minor setbacks. Persistent rumours indicate a mastermind called Omega is behind several of these crimes. Omega symbols have been left at many

of the scenes. Urshukaan originally intended to hire the Travellers to uncover this ringleader but things have since escalated.

He offers the Travellers Cr50000 apiece to find his missing ore carrier, its cargo, evidence against the culprits and especially the ringleader behind it. He is convinced of an outside mastermind because of the planning and sophistication required to not only steal but sell such a ship. He offers a small advance of Cr3000 apiece to cover incidental expenses and bribes. A Difficult (10+) Persuade check (1D minutes, INT or SOC) can bring the advance up to Cr5000 each. If the Travellers agree, Urshukaan has Martin Lukargik draw up the necessary contracts.

Urshukaan introduces them to Marja Aguilar, the manager for Station Three. Because this crime occurred on her station, he holds her responsible. He demands she give the Travellers full access to anything they require and assist them in administering stress detector tests to all suspects.

The Travellers probably have questions. Urshukaan answers what he knows, or defers them to Security Chief Eayukheal. If the questions probe too deeply into the



details of the theft, Urshukaan bruskiy responds that they are the ones hired to find those answers. Once the meeting is complete and contracts signed, Urshukaan dismisses them to begin their job. That evening, he and his retinue board the intrasystem liner and leave Station Three. He returns in one week's time (day 22 of the timeline). When he does, he demands a meeting with the Travellers to review their progress. He leaves Station Three again, two days later.

**Referee Note:** If intending to play *Murder on Arcturus Station* next, the Travellers may see or meet Urshukaan's mistress, Katarin Xuan, during the second meeting.

## THE INVESTIGATION

Once the Travellers end their meeting with Ringiil Urshukaan, they can go several directions with their investigation. Some events, such as the discovery of Captain Hummit Madson's corpse or the discovery of the abandoned Mining Boat GT-56, occur on specific days unless the Travellers uncover those clues early.

### Marja Aguilar

Station Manager Marja Aguilar wishes to speak with the Travellers immediately after the meeting with Ringiil Urshukaan ends. She brings them up to her office on Top Deck. While she knows Urshukaan lacks the ability to fire her, his considerable influence can cause problems for her career. She desperately wants the case solved and offers to aid the Travellers in any way she can, short of breaking the law.

If asked about stress detectors, Marja explains that while there is such a device available at the station, Banasdan Law prohibits their use unless the subject consents to the test. Any evidence gathered without the subject's permission to be tested is inadmissible in Banasdan courts.

She offers the use of a Top Deck office to conduct any interviews. Station security is notified to work with the Travellers but not take orders from them. For safety and security reasons, the Travellers need permission and possibly an escort to enter many of the secure areas. Banasdan Law must be upheld and if the Travellers break the law, even in attempt to solve this crime, they may still be subject to criminal charges while also damaging the case against the ship thieves.

### Researching Captain Madson

Travellers looking into Captain Hummit Madson find a model employee with an outstanding service record. He has no known debts or enemies. Their employer has

### Hummit Madson

**Age:** 45

**Species:** Human

**Gender:** Male

**Employed:** 18 years

**Assignment:** Ore carrier Sabre IV (captain)

**Status:** Unknown

**Certifications:** Spacecraft Pilot, Sensor Operations, Computer Operations, Vacc Suit

**Commendations:** Defending company property. Nonparticipation in employee strike

given the Travellers limited access to the personnel records of Lamarck Minerals employees stationed at Station Three.

### Questioning Madson's Crew

When the Travellers initially arrive at the station, the real crew of the Sabre IV have already been in separate interrogation rooms for two hours. They are frustrated, confused and worried about their captain. None of them know anything about the stolen ship and all swear by Captain Hummit Madson's integrity and innocence. None of their Lamarck Minerals personnel files show any notation of infractions or questionable behaviour (only the most trusted of employees are assigned to ore haulers). All are willing to consent to stress analyser test.

The evening of the Traveller's arrival at Station Three, the crew accompany Ringiil Urshukaan back to Wainwright Starport to undergo further questioning and review. Questioning them after they leave is possible through the station's comms system.

### Xain Fernis, 36. Human. Engineer.

Stocky with curly black hair, Xain Fernis has worked for Lamarck Minerals for 12 years. Immediately after the Sabre IV arrived at Station Three, Xain travelled to Station Two to spend a single day with his fiancée before hurrying back. He returned to Station Three less than an hour before the ore hauler was scheduled to depart.

### Yessid Sast, 40. Human. Engineer.

Bald with a greying beard, Yessid comes from a long line of beltlers. His sister Shandi works maintenance on Station Three and he stayed with her and her two sons. He last spoke with Captain Madson on his second night in the station (day 11) in one of the restaurants.



### **Emily Dinok, 33. Human. Sensor Operator.**

A childhood accident left Emily terribly scarred along the left side of her face. Black tattoos mask most of the damage. She spent the majority of her stay on Station Three gambling in the casino. She recalls seeing Captain Madson there the night before the ship was stolen (day 12) but did not pay him any attention as she was on a hot streak. She ended the night with Cr6000 more than she started with.

### **Aran Bupeel, 42. Vargr. Co-pilot and Astrogator.**

A recovered alcoholic, Aran avoided most of Station Three's entertainments and spent her five-day stay primarily in her stateroom. She is eligible to qualify for ore hauler pilot in four months and was studying for the tests. No witnesses can corroborate her story and she is terrified this incident might spoil her chance for a captain's rank.

## **THE DOCKING BAY**

Station Three's docking bay is much like any other found across the Imperium. Most of the vessels housed here are 60-ton Agrilus mining crafts owned by Lamarck Minerals. There is also a single 1,500-ton Sabre ore carrier (Sabre VII) that docked the same day the Travellers arrived.

A team of workers dressed in Lamarck Minerals jumpsuits service the crafts. Agriluses spend two weeks in dock as their crews enjoy their down-time between deployments. Many spend their break at the station, while most take the liner to Wainwright Starport. Sabre ore haulers spend five days in dock as their inventories are logged and systems tested before they jump away. Most of their deployment time is spent following mining crews out in the belt, being loaded by Agriluses. Once full, they come to Station Three for final preparations.

### **Interviewing the Dock Crew**

The dock crew explains it is not uncommon for a ship's pilot to take a craft out for a test flight. No one considered it strange that Captain Hummit Madson took the Sabre IV out. He is the captain, after all, and their job is not to question him unless there is a mechanical reason for him not to fly the ship. Any crewmember may access the ship with their code, but only the captain is given the personalised code to release the docking clamp. Thus, only Captain Madson could have taken the ship.

An Average (8+) Carouse check (1Dx10 minutes, SOC) uncovers rumours of Ringiil Urshukaan's reputation for mistreating employees, impossible deadlines and too few parts to keep the ships above minimum standards.

Dyrrol Mollik works with the dock crew. He takes note of any Travellers asking questions about the stolen ship. He did work the day of the theft but so did a dozen other people. He claims to have seen nothing out of the ordinary.

### **Interviewing Docking Bay Security**

Security records show Captain Madson requested permission to leave the dock on the day the Sabre IV went missing. The call was through radio and no one actually spoke with him in person. An Easy (4+) Electronics (comms) check verifies this is common practice.

### **Checking Docking Bay Cameras**

Video surveillance shows three individuals enter Sabre IV, their faces hidden beneath hats and goggles. While strange, the attire is not overtly suspicious. Uniform badges and name tape identify one as Captain Madson. The other two, a human female and Vargr male, are unidentifiable, as their name-badges are noticeably smudged.

Performing a facial recognition scan against the Lamarck Minerals employee database requires a Routine (6+) Electronics (computers) check (1D minutes, INT or EDU). Success verifies the man is not Captain Madson. A Formidable (14+) Electronics (computers) check (1D minutes, INT or EDU) identifies the fake Captain Madsen as Hart Fonroe (now beardless). Scanning the woman requires a Very Difficult (12+) Electronics (computers) check (1D minutes, INT or EDU) to identify her as Kari Gimsa with heavy makeup. The facial recognition software, being designed for humans, is unable to identify the Vargr from the little seen of his face. Difficulties may be lowered if scan times are increased.

Lamarck Minerals duty rosters show Fonroe and Gimsa are reported to be currently on the mining craft GT-56 which left earlier the same day and is currently on deployment.

### **GT-56**

If the Travellers know to look for it, security footage shows a single human female entering GT-56 an hour before the Sabre IV leaves. Performing a facial recognition scan requires a Routine (6+) Electronics (computers) check (1D minutes, INT or EDU) check. If successful, it identifies her as Allie Timmon. The craft was scheduled to leave at that time and no one noticed that only a single occupant entered the craft. According to the Lamarck Minerals duty roster, the assigned crew for GT-56 was Captain Hart Fonroe, Kari Gimsa, Boris Davlin and Allie Timmon. All four employees checked-out from the station and reported to be shipping out on GT-56.



## THE STATION BRIDGE

Located on the Top Deck, Station Three's bridge houses the sensor and communications equipment. While records and readouts from the bridge can be accessed from other parts of the station, most notably the docking bay, deeper searches and readings require visiting the bridge and using the equipment directly.

### Sabre IV Readings

As Ringiil Urshukaan said, the Sabre IV's final transponder ping occurred 15 hours after leaving the station, about five million kilometres away. At such range, without the transponder, it is impossible for the station's sensors to detect the ship or any possible wreckage. Sending or taking a ship out to inspect the site would take a 2g mining craft seven hours to reach the location. Of course, the Travellers might wish to order a nearby ship to inspect the location for them, but deployed mining teams, already under harsh deadlines, will not want to stop their work for a task that would most assuredly cause them to miss their quota. Convincing a nearby ship to search the area requires an Average (8+) Advocate or Persuade (1Dx10 minutes, EDU or SOC) check. If successful, the ship reaches the site in 2D3 hours. Nothing useful is found there.

Reviewing the station sensor logs, the readouts only show the Sabre IV. If the Travellers wish to compare it to the logs of any other ships in the area, or if they succeed a Routine (6+) Electronics (sensors) check (1Dx10 seconds), they discover that the GT-56's transponder shows it was at the same location, possibly docked with the Sabre IV. After an hour, the GT-56 continued on as the Sabre IV transponder ceased pinging.

### GT-56 Readings

Sensor logs show the GT-56's transponder currently heading across the system on an unwavering course. It does not respond to any hails. Fifteen hours after leaving the station, the thieves docked the vessel with the Sabre IV, Allie Timmon transferred to the ore hauler and the mining craft was released, continuing along its last trajectory. The Sabre IV's transponder was then disabled and the ore carrier made its way to the secret rendezvous point. Their plan being that when the authorities did come looking for the thieves, they would waste their time chasing an empty mining craft the wrong direction (see Searching the GT-56 on page 14).





## CAPTAIN MADSON'S STATEROOM

Hummit Madson was expected to check out of his stateroom the morning the Travellers arrived at Station Three. So far, no cleaning staff has visited it and have not in several days, because the 'Do Not Disturb' light was activated the morning of day 13. If the Travellers think to investigate the room on their first day, they discover a grisly scene. Otherwise, the discovery is made the following morning by cleaning staff.

The stateroom is a mess, with clothes and personal effects scattered around. The air conditioner blasts at a chilly 16°C. Opening the bathroom door unleashes a sickly stench of blood and decay. Dried blood smears the floor. A male human torso rests inside the shower stall, wrapped in a bedsheet. There is no sign of the head, arms or legs. An Easy (4+) Medic check (1D minutes, INT or EDU) determines he has been dead for at least two days. Determining a more accurate time of death requires the station's laboratory and an Average (8+) Medic check (1D hours). Success narrows the time of death to somewhere between late day 12 and early day 13. The station doctor can also perform this examination.

An Average (8+) Investigation check (1Dx10 minutes, INT) discovers one clue and an additional clue for each point of Effect. Multiple Travellers may roll and uncover whichever clues the referee desires. If a Traveller asks directly about any clue, they automatically succeed in finding it. For example, 'I'm going to look under the bed'.

Increasing the task time lowers the difficulty as usual.

Clues found in the room:

- **Smearred blood along the disposal chute lid.** This is where the severed body parts were dropped into the recycler. Upon discovering the torso was too large to fit and without the immediate means to break it down further, the killers merely wrapped it in a bedsheet and turned the thermostat down to slow decay. Any evidence thrown in the chute has long since been destroyed in the recycler.
- **Empty medicine vial beneath the bed.** An Average (8+) Medic check (1D seconds, EDU) identifies the vial as having contained truth serum. Otherwise the station laboratory can identify the trace contents. Laboratory results take one day to complete but a Traveller can, with Marja Aguilar's permission, use the laboratory to test it themselves with a Routine (6+) Science (chemistry) check (1D hours, INT). The truth serum was used to extract the necessary codes to access the ship from Captain Madson.

- **Missing uniform.** A search of the scattered clothes fails to locate the captain's uniform.
- **Flashtray.** The pile of ashes in the flashtray suggests a lot of use. While the trash and cigarette butts from one or two heavy users might be to blame, the mound of ashes suggests more than two people used the flashtray.
- **Empty delivery capsules.** Two delivery tube capsules lie on a table, implying something had been delivered to the room. Reviewing the station records reveals three noodle bowls and drinks were ordered at 0327 the morning after Captain Madson was last seen (day 13). While the bowls and utensils have been destroyed in the disposal chute, an Average (8+) Investigate check (1D minutes, EDU) discovers a complete thumbprint on one of the capsules. Comparing the print to the station's guest database requires a Routine (6+) Electronics (computers) check (1D minutes, INT) to identify it as belonging to Kari Gimsa.

Reviewing the door lock's records show the room was last unlocked by Captain Madson on the night of day 12. The outer lock was not used again until the crime scene was discovered. The door lock does not record instances when it was opened from the inside.

### Testing the Body

DNA tests of the torso requires an Easy (4+) Medic check (1Dx10 minutes, INT or EDU). Comparison to the Lamarck Minerals employee database verifies the blood and corpse is Captain Madson's. The station laboratory can also perform this test.

Toxicology requires use of the station laboratory. Results by station personnel take 30 hours. Travellers may perform the test themselves with an Average (8+) Medic check (1Dx4 hours, EDU). Success discovers traces of truth serum in his blood, as well as alcohol and a hypnotic drug known as Krash, a substance that criminals often mix with drinks to make their victims groggy and susceptible to suggestion.

## THE CASINO AND RESTAURANTS

Travellers wishing to gather rumours (or catch a bite to eat) eventually find themselves on the Lower Deck. There, the station restaurants and casino offer guests and miners a break from the boring food aboard ships or some much-needed entertainment, all the while separating them from their hard-earned Credits.

Gathering rumours requires an Average (8+) Carouse check (1D hours, SOC). For each point of Effect, the Traveller learns one additional rumour. Referees can



either choose which rumour is uncovered, or choose the one closest in relation to the Traveller's particular line of questioning. Travellers wishing to gamble in the casino make an Average (8+) Gambler check (1D hours, INT). Every point of Effect wins or loses them Cr10x1D.

#### Rumours:

- Under Ringiil Urshukaan's leadership, Lamarck Minerals cut many employee benefits and loosened safety requirements.
- The company has a bad reputation for exploiting tiny loopholes or fine print to avoid paying employees for the smallest of reasons.
- Last year, the mining craft L4-M7 was lost in an accident. While the company claims the accident was due to piloting error, miners believe it was the result of faulty parts Lamarck Minerals had refused to replace.
- After the loss of L4-M7, many of the employee thefts and sabotages began.
- Captain Hart Fonroe took the loss of L4-M7 very badly. He is rumoured to be responsible for organising many of the sabotages. Many employees heard him say Lamarck Minerals would pay for what they did.
- Ore carrier captains are the most loyal and well-treated employees. Everyone is surprised that Captain Hummit Madson would have stolen the Sabre IV, as he was one of Urshukaan's most vocal supporters.
- Captain Madson's supposed theft of the Sabre IV has made him a hero for disgruntled Lamarck Minerals employees.
- Bortai Narayanam, the leader of the still-forming worker's union, has publicly denounced Captain Madsen and his accomplices for their alleged actions.
- Captain Madsen was seen at the casino bar the night before the theft (day 12).
- Captain Madsen was drinking with Captain Hart Fonroe, Boris Davlin and Dyrrol Mollik.
- Captain Madsen got extremely drunk and was last seen being escorted away by his drinking companions. This was the last anyone saw of him.
- If questions are raised about Kari Gimsa being involved, no one believes she would have fled the system without her brother Lance, as they are extremely close.
- Lance Gimsa was scheduled at the last minute to work the BT-23, despite him having just begun his two-week break. Lance was vocally angry about the reassignment and caused a scene in the bar. He left aboard the BT-23 and should be back in the next few days.

Reviewing the casino security cameras with an Average (8+) Investigate check (1Dx10 minutes, INT) sees Captain Madsen sitting and drinking with Hart Fonroe, Boris Davlin and Dyrrol Mollik the night before the theft. A Difficult (10+) Investigate or Recon check (1D minutes, INT) notices Mollik slip something into Madsen's drink. Shortly afterwards, cameras show the three men escort a stumbling Madsen to the elevator. They are last seen heading up to the Middle Deck together.

## SEARCHING THE GT-56

Chasing down the silent GT-56 from the station takes a full day at 2g thrust. Requesting a closer ship to intercept it requires a Difficult (10+) Advocate or Persuade (1Dx10 minutes, EDU or SOC) check. Mining crews, already working under tight deadlines, know that going to investigate a ship might cause them to miss their quota deadline and reduce their pay. Even if they are acting in the company's interest, their contracts hold them to a set quota, and Lamarck Minerals is not known for forgiving missed deadlines, no matter the reason. If the Travellers are successful in either persuading a crew or citing legal reasons for them to investigate the GT-56 despite their quota, the ship reaches abandoned vessel in 1Dx4 hours. If the Travellers are unsuccessful, or do not think to check up on the GT-56, it is discovered and reported by a ship on the fourth day (day 18 of the Timeline) of the investigation.

There is little aboard the derelict mining craft. It is unlikely the Travellers are willing or have the time to journey out to see it for themselves but radio and video reports from the crew either sent to find it, or stumbling across it, can relay the necessary information.

The ship's log indicates GT-56 left Station Three and 15 hours later docked with another ship. The other ship's name has been deleted from the records but Travellers searching Station Three's sensor logs for that time and location can easily see it was the Sabre IV before the ore carrier's transponder stopped working.

A search of the crew cabins discovers them empty of all personal effects. While those items might have been taken with the crew during their two-week stay on Station Three, a Routine (6+) Investigate or Profession (belter) check (INT) realises it is unlikely the whole crew would have brought all personal effects onto the station with them because they were planning to return to the ship.

A search of the craft's provisions discovers the food stocks brought aboard for a several-week mining expedition had been stripped.

A large omega symbol has been painted across the bridge's deck.



## HART FONROE AND HIS CREW

Eventually, the clues should point the Travellers toward Hart Fonroe and his associates.

### Company Personnel Files

The following information can be discovered by reviewing their employee files with Lamarck Minerals. The Known Associates category was added by Eayukheal, Ringiil Urshukaan's security consultant.

In reviewing the profiles of the GT-56 crew, suspecting they might have stolen the Sabre IV, an Easy (4+) Astrogation or Average (8+) Investigate check (1D minutes, EDU) notices than none of them are trained Astrogators. Without a crewmember trained in plotting a jump or operating a jump drive, it is unlikely the thieves could have left the system. Further research into known associates may discover that Lance Gimsa was recently certified in both astrogation and j-drive engineering in the last two months.

#### Hart Fonroe

GT-56

**Age:** 42

**Species:** Human

**Gender:** Male

**Employed:** 7 years

**Assignment:** Agrilus mining craft GT-56 (captain)

**Status:** Deployed

**Certifications:** Small Craft Pilot, Remote

Operations, Computer Operations, Vacc Suit

**Infractions:** Speaking against company. Engaged in three-day strike.

**Known Associates:** Kari Gimsa, Lance Gimsa, Boris Davlin, Allie Timmon, Dyrrol Mollik

#### Kari Gimsa

GT-56

**Age:** 32

**Species:** Human

**Gender:** Female

**Employed:** 8 years

**Assignment:** Agrilus mining craft GT-56 (sensor operator)

**Status:** Deployed

**Certifications:** Sensor Operations, Vacc Suit

**Infractions:** Engaged in three-day strike.

**Known Associates:** Hart Fonroe, Lance Gimsa (brother), Boris Davlin, Allie Timmon, Dyrrol Mollik

#### Boris Davlin

GT-56

**Age:** 40

**Species:** Vargr

**Gender:** Male

**Employed:** 10 years

**Assignment:** Agrilus mining craft GT-56 (mechanic)

**Status:** Deployed

**Certifications:** M-Drive Engineer, Mechanic, Vacc Suit

**Infractions:** Engaged in three-day strike. Suspected involvement in destruction of company property.

**Known Associates:** Hart Fonroe, Kari Gimsa, Allie Timmon, Dyrrol Mollik

#### Allie Timmon

GT-56

**Age:** 30

**Species:** Human

**Gender:** Female

**Employed:** 3 years

**Assignment:** Agrilus mining craft GT-56 (driller)

**Status:** Deployed

**Certifications:** Laser Drill Turret, Reactor Engineer, Vacc Suit, Small Craft Pilot

**Infractions:** Assaulting a co-worker. Engaged in three-day strike.

**Known Associates:** Hart Fonroe, Kari Gimsa, Boris Davlin, Dyrrol Mollik, Lance Gimsa

#### Lance Gimsa

BT-23

**Age:** 30

**Species:** Human

**Gender:** Male

**Employed:** 6 years

**Assignment:** Agrilus mining craft BT-23 (driller)

**Status:** Deployed

**Certifications:** Laser Drill Turret, Vacc Suit, Astrogator, J-Drive Engineer

**Infractions:** Engaged in three-day strike.

**Known Associates:** Kari Gimsa (sister), Allie Timmon, Dyrrol Mollik

#### Dyrrol Mollik

AS-3

**Age:** 38

**Species:** Vargr

**Gender:** Male

**Employed:** 9 years

**Assignment:** Arcturus Station Three (Dock Crew)

**Status:** Active

**Certifications:** Mechanic, Loader Operator, Reactor Engineer

**Infractions:** Suspected involvement in destruction of company property.

**Known Associates:** Hart Fonroe, Kari Gimsa, Lance Gimsa, Boris Davlin, Allie Timmon



## Lance Gimsa

At the start of the adventure, Lance Gimsa is deployed on mining craft BT-23. While aware of the plot, he took no part in the murder and theft of the Sabre IV and has had no contact with the thieves since he departed Station Three. His plan is that once he returns to the station, he and Dyrrol Mollik will take a mining craft and head to where the Sabre IV is hiding. Once aboard, he begins making jump calculations for their escape.

If the Travellers try to contact him, he claims ignorance of the whole affair. Afterwards, he messages Dyrrol about the Travellers, asking him to handle it. Record of this message can be found in both of their computers afterward. His craft is 30,000,000 kilometres from Station Three. A 2g ship would take 21.5 hours to reach him. Lance is confident enough in his alibi that if the Travellers do go out to meet with him, he will not resist.

Interrogating Lance can be performed through Advocate, Deception, Persuade or Streetwise checks. Each attempt requires 1D hours and requires a Very Difficult (12+) success for him to confess. A Traveller's skill level in Profession (belter) can act as a positive DM if they try to make a personal connection.

Lance knows where the Sabre IV is hiding. He cares very deeply for his sister Kari Gimsa and will not betray her. However, if he feels a confession might save her from being harmed, it grants DM+2 to the interrogator's check. If the Travellers know for certain where the Sabre IV is hiding (either from his confession or other means) he can be convinced to help them get onto the ship if that means it might save his sister's life.

## Dyrrol Mollik

Working as a mechanic and loader in Station Three's Docking Bay, Dyrrol Mollik is quite confident he is above any suspicion. His job with the criminal crew is two-fold. First, he is to monitor the situation at the station and help deal with any setbacks. Second, once Lance Gimsa arrives, he preps a single Agrilus mining craft and modifies the logs to show it as being scheduled to go out on a test flight. Dyrrol keeps the coordinates of the Sabre IV's location on his computer but the computer is hidden in his work locker. It requires a Difficult (10+) Electronics (computers) check (1Dx4 hours, INT) to hack his computer.

If questioned about his known association with Captain Hart Fonroe and his crew, Dyrrol admits they are friends but denies all knowledge of the murder and theft. If confronted about rumours, or video footage of him

drinking with Captain Hummit Madson, he claims that while he did escort Madson to the elevator, he went directly to his stateroom afterwards, leaving him in the care of Captain Hart Fonroe and Boris Davlin. If confronted with footage of him slipping something into Madson's drink Dyrrol claims Fonroe paid him Cr100 to do it as a joke and he did not know what the pill was. However, confronting him with this evidence grants DM+3 to all following interrogation rolls.

Interrogating Dyrrol can be performed through Advocate, Deception, Persuade or Streetwise. Each attempt requires 3Dx10 minutes and requires a Very Difficult (12+) check for him to confess. A Traveller can only attempt a single method once. Multiple attempts, even from other Travellers, work as a task chain.

- Effect 0 gets him to admit he knew Fonroe and his crew were planning something big but he did not know what.
- Effect 1 gets him to confess he knew the plot but backed out when murder was suggested. Fonroe and his crew then left him without saying where they were headed.
- Effect 2, he offers Lance Gimsa as someone who knows where the Sabre IV is.
- Effect 3+ or more earns a full confession.

Without evidence or a confession, Banasdan Civil Code requires he be released from holding after 12 hours, although suspects can be prevented from leaving Station Three for up to 72 hours.

Once the Travellers start poking their noses into the investigation, Dyrrol takes immediate action. The degree of his response is dependent on opportunity or how close he feels the Travellers are getting. He has the skills to break into any stateroom and attempt to attack a Traveller in their sleep. An Average (8+) Recon check (INT) hears him enter their room. Alternatively, Dyrrol may attempt to lure one or more Travellers to one of the more isolated parts of Module B with a 'clue' or anonymous tip and then try to kill them. If the Travellers attempt to leave the station, he sabotages their ship, causing both their comms and manoeuvre drive to cease working after one hour of flight. Fixing them requires an Average (8+) Electronics (comms) and Engineer (m-drive) check (1D hours, EDU or INT). If unable to repair either, the craft drifts for 16 hours until they are noticed and help arrives.

If the Travellers come for Dyrrol and he feels they have evidence against him, Dyrrol tosses his computer into a disposal chute and defends himself with his body pistol.



**Referee Note:** Dyrrol Mollik is the referee's wild card to inject excitement into the game if the Travellers hit a wall. They may discover someone has entered and tossed their room or discover a death threat warning them to back off slipped under their door.

## ASSAULT ON SABRE IV

Discovering the missing ore carrier's location can be accomplished in several ways; extracting a confession from Dyrrol Mollik or Lance Gimsa, finding the location on Dyrrol's computer or attempting to follow Dyrrol and Lance to the rendezvous.

How the Travellers use this information is up to them. They have the authority to use one of the Agrilus mining craft in the docking bay. If they attempt to seize the ore carrier themselves, they may be in for a boarding action while taking fire from the Sabre IV's turret. They may try to pose as Mollik or Lance with a Difficult (10+) Deception check (1D minutes, INT or SOC), dock with the ore carrier and seizing control once they are inside. This task works far easier (DM+4) if they have either Mollik or Lance aboard and on the comms.

Shipboard combat may be an exciting end to the adventure as the Travellers make their way to the bridge to take control. Some of the criminals may be killed or captured in the exchange. However, one certainty is that

Hart Fonroe dies. Whether it be in combat, murder by one of his own crewmates or suicide the moment the Travellers enter the ship, is up to the referee to decide. With his death, the Travellers cannot learn the planned jump coordinates or uncover who the mastermind and buyer were behind the plot.

## A Job For The Police

Alternatively, the Travellers may simply call this one in and have a patrol cruiser sent from Wainwright Starport with its detachment of Banasdan Port Authority Police. The cruiser takes four days to reach the Sabre IV from Wainwright and if the thieves have Lance Gimsa aboard to plot a jump, they escape. If the Sabre IV is unable to jump or lacks their astrogator, the patrol cruiser has little problem in taking the ore carrier. All of the criminals and two of the police die in the encounter but the Sabre IV and her cargo are recovered.

## CONCLUSION

The adventure ends with either the escape or capture of Sabre IV. Any evidence gathered against surviving conspirators is used in their arrests and trials. However, with the escape or death of Hart Fonroe, Omega's identity and where the Sabre IV was heading, is never learned. While this may seem as a small detail to the Travellers, it gives Ringiil Urshukaan enough legal excuse to refuse payment on the uncompleted contract. How this news is delivered and plays out is covered in the next adventure, *Murder on Arcturus Station*.





# ADVENTURE 2: MURDER ON ARCTURUS STATION

*Murder on Arcturus Station* is a Traveller murder mystery, in which the Travellers unravel clues to discover the murderer of a wealthy businessman.

This adventure is intended for use with any group of Travellers; they may be any sort of individuals as long as they are looking for some type of paid employment. The text of the adventure can be altered to suit nearly any type of Traveller group. In this adventure, a wide variety of skills may come into play. Some skills of particular value would include Medic, Streetwise, Admin, Electronics (computers) and the like. In the end, however, the usefulness of any skill depends on how the players use their characters.

*Murder on Arcturus Station* is unlike most Traveller adventures. The material allows the referee to set up any of a variety of different specific situations. The fact of a man's murder is a constant; the referee, however, determines how the murder was committed, who did it and what clues – helpful or misleading – are available for the Travellers to use in their attempts to solve the mystery.

Thus, instead of providing many specific events, encounters or other plot elements, this adventure is largely devoted to the presentation of source material from which the referee must build the specific mystery to be presented. Consider it a toolbox. Familiarity with the process of creating the mystery is important, as is advance preparation. The reward for this extra effort is an unending variety of situations, in which the murderer can prove to be anyone – a business associate of the victim, a star-crossed lover, a personal enemy – even one of the Travellers themselves. And, in the best tradition of classic mysteries; the referee can incorporate a variety of other elements, as desired, so that multiple murders, cooperation between two or more killers and other plot devices can be introduced (or not) entirely according to the referee's whim.

This variety keeps *Murder on Arcturus Station* fresh and useful for session after session of *Traveller* play.

## STARTING THE ADVENTURE

Before beginning, the referee has a great deal to do. They must first read through the entire adventure. Then they must determine the details of the crime, as explained in *Creating the Perfect Murder* on page 21.

Only after this is the referee ready to involve the Travellers. If not using this scenario in conjunction with *The Hunt for Sabre IV*, the referee should first inform the Travellers of the basic background information.

Next, run the Travellers through the events in *Death on Station Three*. Although it is possible merely to read the text to the Travellers, a better method is to allow them to interact with the characters encountered.

Once this first portion has set the background to the mystery, the adventure begins as the Travellers set out to solve the murder mystery and bring the criminal to justice.

## DEATH ON STATION THREE

The job had been a hard one but the Travellers pulled it off. The missing ore carrier belonging to Lamarck Minerals, LIC was discovered deep in the Arcturus Belt and a plot by disgruntled employees to steal the vessel and flee the subsector was uncovered and nipped in the bud. Now the Travellers are back at Arcturus Station Three to meet their employer, Ringiil Urshukaan, the president of Lamarck Minerals. Here they plan to collect their payment and await the arrival of the intrasystem liner to ferry them to Wainwright Starport and a ship bound outsystem.

Perhaps they should have listened more closely to some of the stories the miners told concerning Lamarck Minerals and Urshukaan's usual treatment of employees.



## Interview

Ringiil Urshukaan and his entourage – plus several other passengers – arrive via the weekly intrasystem liner a few days after the Travellers completed their mission on Station Three. The liner leaves before the party can schedule a meeting with Urshukaan; they now have to await the arrival of the next liner in a week's time.

Urshukaan does, at length, consent to see the party. While they are waiting for him, they hear a loud argument between Urshukaan and some other individual, during which threats against Urshukaan's life are uttered (**Incident 1**).

**Referee Note:** The referee must decide the identity of this individual, as well as the others who are later observed with Urshukaan (see *Incidents 2 & 3* on pages 22), when determining the other facts of the crime. Although the Travellers may not be aware of any identities at this time, these facts may eventually become important.

Urshukaan is in a foul mood after his bodyguards eject the quarrelsome person and escort the Travellers into his temporary office. Hot-tempered and impatient, Urshukaan's red face and heavy breathing show how upset he was with the previous visitor. He proceeds to take out much of his anger on the Travellers.

The Travellers are told in no uncertain terms that Urshukaan is dissatisfied with their performance on the job they just completed. Although they recovered the Sabre IV ore carrier, and gathered evidence against the plotting employees, they failed to capture the ringleader and took too much time to carry out the task. Urshukaan has decided, therefore, that Lamarck Minerals will not honour the contract – in accordance with a non-performance clause that permits him to do this with perfect legality. The Travellers have been cut off completely from the Cr50000 apiece promised at the beginning of the mission and have nothing to show beyond a small advance against expenses now more than used up during the mission itself.

**Referee Note:** If using this adventure in conjunction with *The Hunt for Sabre IV*, the specifics of the Travellers' work should be referenced by Urshukaan during this meeting. At the very least, the Travellers did not capture or learn the ringleader's identity.

Urshukaan is completely indifferent to threats of legal action. The clause is sufficiently vague and his financial resources sufficiently greater than the Travellers', that he has no cause to worry. An Average (8+) Advocate check (1D minutes, EDU) verifies the Travellers legal recourse is tentative at best. Should the Travellers become personally abusive or threatening, he has his bodyguards eject them none too gently. His callous attitude may well provoke one of the Travellers to make threats, just as the last visitor did.

As they make their way out, the Travellers see Urshukaan's assistant, Martin Lukargik, talking to the president. They cannot hear what the assistant says but they do hear Urshukaan's outburst in response. *'God, another one who's out for my blood! All right, show the bloody fool in. We might as well get this over with now!'* The Travellers may get a glimpse of one or more people in the waiting room, obviously waiting for a chance to see Urshukaan (**Incident 2**).

After the interview, the Travellers go about their own business. In the evening, they witness a brief altercation between Urshukaan and yet another disgruntled individual (**Incident 3**); following this disturbance in the station lounge, Urshukaan withdraws to his cabin.

Some four hours later, Ringiil Urshukaan is discovered dead in his room and the evidence points to murder.

## Dilemma

Urshukaan's murder sends a shock throughout Arcturus Station Three. The Travellers are awakened from a sound sleep and brought to see the station manager, Marja Aguilar, not long after the body's discovery.

Aguilar is faced with a dilemma. She does not have the resources at Station Three to investigate a murder. The corporate enforcement personnel at the station cannot be used – they are security officers and the chance of bias makes them doubly unusable for this investigation.

She has placed a call to Wainwright Starport, summoning a detachment of Port Authority police. But Wainwright Starport is on the far side of the system from Station Three; even at maximum acceleration, the patrol cruiser cannot arrive at the station in less than three days. When it does arrive, they have only two days more before the intrasystem liner arrives at the station.

As station manager, Aguilar can hold traffic, in and out of Station Three for up to a week. Doing more requires a special order from the police inspector at Wainwright. But he, as Aguilar well knows, is an





ambitious bureaucrat with few friends but a great deal of caution. Some of the suspects have influence and he is not the sort of person to risk his career by detaining such individuals. Aguilar is sure the inspector will allow the suspects to leave once the liner is in – which means that, if the murderer’s identity has not been discovered by then, he or she is gone for good.

Marja worked with the Travellers during their search for Urshukaan’s ore carrier and has become a good friend. They impressed her with their ability to track down leads and solve problems, and although they are among those being checked out (thanks to Urshukaan’s treatment and their own angry responses), she is convinced they could not be the killers. And she needs help. Her staff does not even know where to begin to start looking into this and the delay in the arrival of the police is a waste of vital time. If the murderer is to be brought to justice (and Aguilar wants this very badly, no matter how people may have felt about the dead man), the investigation has to start now. Aguilar wants the Travellers to help her do it.

She is asking as a friend but offers an appealing compensation as well. First, she can cover all costs for the party’s stay on Station Three, plus passage via liner back to the starport and a government priority middle

passage for each member of the group to Banasdan. However, the main attraction of the offer is that she knows the vice president of operations for Lamarck Minerals; he is an old friend who owes her a favour or two. She thinks she can get him to pay off the money Urshukaan withheld but he is most likely to do so if Urshukaan’s murderer can be caught. So, if the party will help her out of her current dilemma, Aguilar will do everything she can to arrange the payment. Since the corporate official involved is currently on Banasdan, the party (with a letter of introduction from Aguilar) can collect once they reach that planet.

Aguilar cautions the party that Inspector Dragovitch, the police inspector en route, is not likely to trust the Travellers. Whatever evidence they uncover must be solid enough to convince him. Otherwise he is likely to seize upon some suspect of little influence, build a circumstantial case and leave it at that. Aguilar also reminds them their own influence is scant; without some pretty convincing proof, they themselves could – and likely will – become the inspector’s scapegoats.

Aguilar places an office and a computer terminal at the group’s disposal, as well as other station facilities (the dispensary and labs, for instance). She and her staff provide what help they can, normal duties permitting.



Computer records can also be obtained from the starport within a few hours. The group is cautioned that the suspects are all to be treated with consideration for their rights, as is guaranteed by the Banasdan Civil Code.

With these warnings, the station manager leaves them to their task; to sift through a welter of clues and suspects to discover who murdered Ringiil Urshukaan and bring them to justice.

## CREATING THE PERFECT MURDER

*Murder on Arcturus Station* is unusual in that the course of the adventure is more thoroughly shaped by the referee than is usual. This section discusses the procedures by which the referee creates the murder, a process which allows nearly endless variation, different degrees of complexity and as much input as the referee desires to add to make the situation unique.

### Preparations

Before beginning the adventure, the referee should work out the nature of the mystery. Advance preparation is absolutely essential; referees are strongly advised not to attempt to improvise the situation on the spot!

The first consideration to be made is of the game's complexity. Complexity is established by determining the number of suspects, the diversity of their motives and the number of clues and red herrings to be used. Decisions made at this time will directly influence the level of uncertainty – and hence the excitement – of the adventure proper.

Descriptions are provided of 10 different suspects. These predetermined suspects break down roughly into three groups of three, with each group revolving around a different general motive for killing Urshukaan. Thus, one group is business oriented, a second centres around Urshukaan's background, while a third involves a romantic triangle.

A very simple murder mystery revolves around three suspects, all with a similar motive. This is straightforward and uncomplicated, involving little need to narrow down conflicting motives or multiple suspects and/or red herrings. Complexity can be added by mixing up motives – perhaps one suspect is drawn from each triad, rather than having all come from the same one. Greater complexity can be inserted by increasing the number of suspects as well.

A case of fair complexity would involve the presence of all 10 given suspects. Not all would be suspects for very long – evidence might almost immediately narrow the field considerably. Although interaction with all the suspects would still be possible (and desirable) and it is this area that leads to the heightened complexity of the situation.

The truly ambitious referee can go a step or two further. First, additional suspects can be created by following the basic format of the given suspects. Secondly, special cases can be developed. Collusion between two or more suspects is a possibility (consider *Murder on the Orient Express* by Agatha Christie as a source) or a case that looks like a murder could, in fact, be suicide (see *Clouds of Witness* by D. L. Sayers). Such expansions on the basic situation are in the province of the referee, adapting and modifying the basic material presented here as desired.

Finally, the ultimate in complexity is achieved by having the murder committed by one of the Travellers.

Once the murder and basic nature of the suspects has been determined, the referee proceeds to establish the facts of the murder itself. During this process, all the salient facts of the mystery are developed and set forth. The process follows a set, step-by-step course.

First, the murderer is selected from the pool of suspects. The description of the suspect provides all information necessary to determine motive, means, alibi and so forth. A number of clues are also summed up that will point at the suspect.

The second step is to select other suspects. Once again, the wide variety of available suspects makes it possible to alter the balance of play considerably. If the suspects are each the sort of individuals who would carry out the murder in a similar fashion, the resulting case will be harder to solve than one in which the means is easily traced to a particular individual. For example, a stab in the back from a dagger, which is found in the room, takes on extra significance when it is realised that one suspect, the Aslan officer, is psychologically incapable of killing in such fashion, while a second, Urshukaan's hated opponent M'Banke, would never have been able to strike from behind with a dagger (Urshukaan was too cautious for that). The murderer might be quickly spotted by a process of elimination. Thus, care must be exercised to keep the murder from being too obvious – either by choosing more than one suspect who might have committed the crime in such a manner or by introducing other evidence that counteracts the basic simplicity of an uncomplicated situation like this example.



Once the suspects have been chosen, a murder timetable is created. Plot the movements and activities of each suspect prior to, during and just after the murder. Facts are filled in from the suspects' descriptions and rounded out by the referee with embellishment as desired.

Prior to the murder, three Incidents are witnessed by the Travellers:

**Incident 1:** Before the meeting

**Incident 2:** At the end of the meeting

**Incident 3:** After the meeting

These Incidents serve as initial clues and provide the Travellers with their initial suspects. One, or maybe none, of those characters may be the murderer but the Incidents serve as a means to quickly put the Travellers on the trail of multiple suspects.

With the timetable completed, additional clues are filled in. These clues are the red herrings that may point to suspects other than the murderer. The clues should be based upon the movements of each suspect; thus, a suspect who met Urshukaan before the murder might have left fingerprints on a glass in Urshukaan's room, but this clue would not be present if the suspect did not go near Urshukaan's room at all.

The last step to consider is optional; it concerns the interaction between the characters. In this step, the referee might decide the murderer has deliberately chosen to incriminate another suspect (thus supplying further red herrings but, possibly, additional clues to the murderer's true identity at the same time) or it may be established that one suspect has decided to cover up for another, possibly leading to suppression of knowledge or evidence, a false confession and so forth. The extent of this final step should be regulated by the referee, based on the suspects involved and the degree of complexity desired. The last part of this section gives some guidelines for the referee uncertain of how to set up this aspect of the mystery.

## SUSPECTS FORMAT

Descriptions of suspects follow a specific format, as is outlined here. Suspect information is split between two areas.

*Characters and Opposition*, on page 49 contains:

**Basic Information:** Name, skills and so on.

**Known Background:** In this part, generally known information about the suspect is presented. This includes all background, which is 'public knowledge', any data

easily located in computer records and anything the suspect freely admits about their past. A physical description may also be included in this section.

Less available information is found under each character's profile in the *Suspects* section on page 31:

**Involvement:** This section describes how the suspect is likely to come to the Travellers' attention. The referee is free, however, to modify this information in the interests of tightening or altering the plot line of the mystery.

**Other Background:** All information that is not readily available to the Travellers is contained in this section. This includes material that can only be unearthed by a particularly diligent computer search or information that is admitted to by the suspect only under pressure.

**Motive:** This is the suspect's motive for murder. Suspects who did not perform the murder still have this motive – a deep, dark secret in their lives, which gives them a good reason to be glad of Urshukaan's death or which causes them to behave in a secretive fashion.

**Means:** This is a description giving at least two different ways the suspect might have committed the murder. These alternatives vary somewhat from suspect-to-suspect (although there is overlap). Following each of these means, the clues that might be left behind by the suspect are then provided. Some tie in to the specific means, while others are general clues, which point to the suspect even if he or she is not the murderer.

**Alibi:** This section relates the suspect's alibi, if any. It describes how the alibi is supported (by witnesses or other evidence); if the suspect was the murderer, this section also shows how the alibi was maintained even though the suspect killed Urshukaan.

**Reaction Values:** This is more fully explained in the section on *Questioning and Character Interaction*, on page 27. The reaction rules show ways in which the suspect can help or hinder the investigation.

**Notes:** This section gives additional information of help to the referee, if any.

## The Murder

The referee chooses from among the suspects to determine who has committed the murder. From the choices given for that suspect under Means, the actual course of the crime is plotted as well. Means not only gives information on how the murder itself took place; it also gives a short summary of what went on before and after the crime, and provides the body of clues, which actually point to the murderer.



False leads are listed in a separate part of this section, which describes what went on if the suspect was not the murderer and the misleading clues that might, as a result, appear.

## Alibis

Suspect descriptions include a section on alibis. These alibis give the story the suspect tells concerning his or her whereabouts and movements at the time of the murder. Some alibis are 'layered' – one story may be replaced by another if the suspect is trying to hide something.

The referee is responsible for determining which alibi a suspect begins with, if such layering exists. There will be some suspects who have no alibis and some who will stick to a single story, regardless.

Alibis may (or may not) be supported externally; the suspect description will indicate this. For example, a suspect may claim to have been in the station lounge until well after the murder and might be able to produce several witnesses to this fact. Other alibis may be totally unsupported.

Suspects with strong alibis have been given a short description of how the alibi is maintained if they actually did commit the murder. In the course of investigating the case, the Travellers may be called upon to break a seemingly unbreakable alibi, in the best traditions of detective fiction.

## Character Relationships

The various suspects may, through their relationships, provide alibis, evidence and other important plot devices for the mystery. The relations between characters are largely determined by the referee, using the background information on the suspects in use during the current adventure. Some extrapolation and creativity may be required to supplement the basic information available.

The Suspect Relations table gives the referee the opportunity to construct some elaborate relationships between suspects. Roll 2D for each suspect; on a 7+ the table is consulted; roll 2D again and record the corresponding result – of course, the referee is always free to choose a specific set of results rather than roll the dice. The murderer uses the Murderer Relations table, which regulates that individual's attitudes and actions after the murder.

## Suspect Relations

2D	Result
2	Suspect knows the identity of Urshukaan's killer but is keeping silent for the moment. The suspect has confronted the murderer with this knowledge. The murderer's response can be determined by a Reaction check (see page 27); Effect -6 or less means the murderer attempts to kill the suspect or implicate them in the crime in order to keep him or her quiet; Effect 3+ indicates an attempt by the murderer to placate the suspect through payment of blackmail and so forth.
3	Suspect has correctly guessed the murderer's identity and is shielding them with false alibis, clues or even a confession of guilt. The referee should develop a motivation for this and determine specific actions taken.
4-5	Suspect wrongly believes another suspect killed Urshukaan and declares this belief to the Travellers. Supporting evidence on motives, hidden background information and so forth. which would reasonably be available to the character can be brought forward. The referee must choose the suspect falsely accused and may have to expand upon relationships to develop the overall motivations of the two suspects in question.
6-7	Suspect has no particular beliefs concerning the murder but is very cooperative. Background information that might otherwise be kept hidden is shared willingly.
8-9	Suspect is very uncooperative. All Reaction checks gain DM+2.
10	Suspect wrongly believes another suspect killed Urshukaan, and attempts to protect them through false alibis, clues and so on. The referee should develop a motivation for this and determine specific actions taken.
11	Suspect has correctly guessed the identity of the murderer but has no proof. As in 4-5, above, information is shared freely with the Travellers.
12	Suspect is working in collusion with the murderer and fully supports any alibi the murderer advances. Roll 2D; on a 9+ the suspect cooperates with actions taken by the murderer after the fact.



## Murderer Relations

2D	Result
2	Murderer attempts to kill investigators who seem to be getting close. The referee must determine when and if this happens and the results of such a move.
3	Murderer kills any suspect who knows or guesses too much about the crime (a roll of 2, 3, 11 and possibly 12 on the Suspect Relations table). Subsequent murders should be set up very much like the basic murder, with the referee determining clues, alibis and so forth as needed.
4-5	Murderer does nothing unless the investigation seems at the point of solving the mystery. As soon as the murderer is sure the crime has really been solved correctly, they hatch an escape plan to take hostages at the station and force the authorities to provide transportation outsystem. The outcome then depends upon the interaction between the Travellers and the referee.
6-8	Murderer claims innocence and takes no action at all.
9-10	Murderer plants clues pointing towards one or more other suspects.
11	Murderer claims to have witnessed another suspect entering Urshukaan's room at the time of the crime.
12	Murderer takes another suspect into confidence and reveals guilt. The actions of the suspect in response are determined by the referee, using the information for the suspect in question (if any). On an Average (8+) INT check, the murderer regrets this lapse (reroll on this table).

**Referee Note:** These tables deliberately leave many things up to the referee. In staging the mystery, it is ultimately the inter-relationships between suspects that lends the greatest interest to the adventure. But to avoid overly mechanical solutions, it is best for the referee work out the details.

Referees are encouraged to introduce other options into the tables, as desired. In all cases, strive to fit the various results into a coherent whole, even if it requires the addition or alteration of backgrounds on specific suspects. For example, suppose Urshukaan's estranged wife is the murderer. The victim's chief detractor in the local Independent Belters' Association, M'Banke, is indicated as knowing about the crime and helping to cover it up. It is up to the referee to fill in missing details – perhaps Urshukaan's wife stands to inherit sufficient stock to make or break M'Banke's plans with the IBA. Perhaps the two have some personal or business relationship that explains this support. In each case, relationships should be set up carefully to make the interaction smooth, logical and, above all, real.

## A TRAVELLER AS MURDERER

One of the most challenging and potentially exciting adventure possibilities is a mystery in which the murderer is in fact one of the Travellers. In this case, the other Travellers are not aware that one of their own is a criminal actively attempting to confuse the trail.

Given a plethora of suspects and a natural assumption of Traveller innocence, the insertion of this active opponent into the adventure can make for an exciting and interesting mystery.

### Preparation

As with the standard adventure, this requires some advance preparation on the part of the referee. One of the Travellers must be chosen to play the part of the murderer. The referee should choose carefully as to which Traveller, if any, can be trusted to play this in the full spirit of the role. It is suggested that this Traveller and the referee get together prior to the game session to work out several points of importance to the adventure in advance.

The referee should explain the background to the Traveller and then work with them to develop the murder plan. This becomes, in effect, a one-on-one adventure, with the Traveller-murderer determining the method of the murder, while the referee regulates events to provide hazards or opportunities for the Traveller-murderer to deal with. The Traveller-murderer should be encouraged to develop as elaborate a scheme as is desired to set up an alibi, throw suspicion on other suspects (including other Travellers) and so forth. Careful track should be kept of events and times, so the referee can set up suspect worksheets and regulate other events.

Other preparations go as usual. However, one special procedure must be followed to establish the number and type of clues the Traveller-murderer leaves in committing



the crime. After all else is finished, the number of clues left is established by the Traveller-murderer making a Difficult (10+) INT check. If failed, the Effect determines the number of clues left behind. If the result is successful, the Effect is the number of false clues the Traveller-murderer may leave, either accidentally or deliberately, pointing to other possible suspects. These false clues are in addition to general clues, which other suspects may leave. If the Traveller-murderer has announced a definite intention to incriminate someone else, then all the false clues should point to this suspect.

If not, it is up to the referee to select clues from a variety of characters and apply them as desired. The actual nature of clues left by a Traveller-murderer can be derived in several ways. For the greatest fairness, the Traveller-murderer and the referee should together compile a list of possible clues once the murder plan has been worked out. This is a process requiring logic, creativity and a sense of what is possible in the real world. It is necessary for both the Traveller-murderer and the referee to approach the creation of these clues with a willingness to be reasonable. Since the number of clues is not established until after the natures of the clues are determined, a large and diverse group should be created from which the specific clues can be drawn. The referee does this secretly, after the Traveller-murderer's participation is complete. The Traveller-murderer should know neither the number nor the specific nature of the clues available, unless they resort to the classic 'return to the scene of the crime' – a dangerous alternative.

**Referee Note:** When establishing clues, keep the following facts in mind. First, clues should not be too blatant – unless the Traveller-murderer is of very low INT. Secondly, clues should not conflict with the way the crime was committed. If the Traveller wore gloves throughout, fingerprints are unlikely as clues. Finally, both the Traveller and the referee should have a strong voice in determining the nature of the clues. This ensures fairness. In this game, the Traveller-murderer and the referee must work together but they cannot allow the situation to become completely unbalanced. Thus, the referee should be the one who strives to come up with clues, which serve to point to the murderer. The Traveller may try to suppress these, arguing that they would not have allowed such a thing to happen. In case of unresolvable differences of opinion, the referee of course has the final say on inclusion of any clue, although they should make every attempt to be fair.

## The Adventure

Once all is set up, play proceeds as usual. All the Travellers, including the Traveller-murderer, should be led through the adventure from the beginning. It is up to the Traveller-murderer to separate from the other members of the party during the times worked out for the murder. This can be done in any manner the Traveller-murderer desires (even including the use of force against other Travellers, if this is desired).

The group is approached as before and asked to find the criminal. As the bulk of the party works to discover the killer's identity, the Traveller-murderer may attempt to plant false evidence, suppress actual discoveries or even eliminate other individuals in an attempt to confuse or complicate the search. The Traveller-murderer determines all activities, without restraint, but also has to live with the results of these actions.

**Referee Note:** This adventure requires a great deal of communication between the Traveller-murderer and the referee. To disguise the nature of this communication, the referee should encourage the group to split up and pursue separate lines of inquiry and then impose the requirement that questions, answers and actions must all be communicated by notes to the referee while the party is not together. The ostensible reason is to limit the data available to the Travellers and leave open the possibility of important clues being overlooked by the insufficiently attentive. Actually, of course, the notes allow the Traveller-murderer to inform the referee of special activities – planted evidence, an ambush and so forth – which cannot be safely discussed without creating suspicion.

The referee might want to use this system of notes and limited information in all games of Mysteries on Arcturus Station. Although it slows play slightly and is only essential for Traveller-murderers, it is still a good idea – both for the reasons stated previously, and to keep players familiar with the precepts of the adventure from determining whether the murderer is a Traveller or other character. The slower time flow, too, can be turned to advantage; this is a thinking adventure, by and large, and time should be made available in which Travellers can go over clues and come up with new lines of endeavour.

## Conclusions

The Traveller-murderer is striving to escape justice. How this is done is entirely up to them. It is possible the murderer takes other Travellers into the plot in order to cover the trail more thoroughly. Other Travellers may act as they see fit, if they learn of their companion's crime.



The group's goal is to try to discover the murderer. They may decide to falsely arrest some other suspect or they may seek justice and turn their fellow Traveller in.

If other Travellers are caught with some proof of involvement, either before or after the fact, in this crime, they may face the same fate as the Traveller-murderer.

## INVESTIGATING THE CRIME

The Travellers are required to collect information and clues, analyse data and deduce the identity of Urshukaan's murderer. To do this, they may follow any of a number of possible procedures, in any combination desired. No one path is likely to produce all the information required; it will be important to balance alternatives against one another, applying skills in several directions and combining the results gained from different endeavours to produce the answer needed.

### Forensic Science

The gathering and analysis of physical clues makes up the body of knowledge known as forensic science. This may include such items as fingerprints, the analysis of bloodstains or strands of hair and other similar evidence of a solid, concrete nature.

In order to gather evidence of this kind, Travellers must indicate their intentions. A search must be directed at a particular area or item. The more confined the search is in scope, the more likely clues are to be uncovered.

Clues connected with the item or area being searched are discovered if the Travellers makes an Average (8+) Investigate check (1Dx10 minutes, INT). There are several DMs that may be employed: DM-2 if the search is of a room, corridor and so on; DM-1 if the search is of a body; DM+1 if the search is of an artifact; DM+1 if the Traveller is looking for a specific type of clue (and such a clue is present); DM-2 if the search is interrupted. Of course, increasing the timeframe of the search increases the chance for success.

The timeframe to be spent on the search should be announced and rolled by the Traveller(s) before the check is made. The referee should throw 1Dx30 minutes, secretly. If the referee's resulting time is less than or equal to the time rolled by the Traveller, the search is interrupted. The nature of the interruption depends upon the nature of the search and the desires of the referee. It may be a distracting call or it could be the return of a suspect to a room the Traveller is investigating. The consequences are in the referee's hands.

Depending on the situation of the search, other skills may be used instead. For example: a Traveller could apply medical expertise (the Medic skill) to a examine a body; a Traveller looking for signs that an electrical apparatus was deliberately rigged to impart a lethal shock would use an Electronics skill; identifying the type and manner of an explosive used would use Explosives and so forth.

Discovery of items such as fingerprints, hair, blood and so on requires that these clues be matched up with information from suspects and analysed by someone experienced in the proper field.

Thus, the discovery of a fingerprint on the murder weapon does not help until each suspect's fingerprints are taken and compared. Fingerprinting is not widely used as a method of identification; retinal scanning is much more accurate. However, guests of Station Three may have thumbprints on file in order to access rooms and Marja Aguilar can give them the authorisation to check any thumbprints against the station database. This could be thwarted by gloves or if one or more suspects opted to use retinal scan or keypads to access their rooms. In cases where there are no suspect fingerprints on file, Travellers must secure the prints, either through persuasion (see *Questioning and Character Interaction* on page 27) or by some less open approach.

Bloodstains, hair, DNA and other organic samples may be compared in a medical laboratory by anyone succeeding an Average (8+) Medic check (1Dx4 hours, EDU). Again, samples must somehow be obtained from suspects for comparison.

This is true of other, similar clues, as well, and the possibilities of red herrings, false evidence and so forth make it quite possible that these clues alone may not be sufficient to prove the murderer's identity.

### Research

Travellers do not start off with any sort of detailed knowledge of any of the suspects or of the possible connections between some of them and Urshukaan. Research is of vital importance to any attempt in uncovering such material.

To do research, Travellers must have access to a computer terminal. Electronics (computers) skill is not necessary (anyone can enter the proper requests for data) unless a Traveller-murderer wants to insert data into a file on one of the other suspects in order to confuse the issue or focus suspicion on others. In this case, they must succeed an Average (8+) Electronics (computers) check (1Dx10 minutes, INT) to plant the information.



For ordinary research, Travellers need only announce the specific topic they wish to examine. Topics available are all entries listed in *Library Data* on page 61, some of the generally available background material on the more prominent of the suspects and any other items the referee cares to make available.

Another source of information is computer records from the starport. For most of the suspects, this is purely routine information gathered upon arrival; name, world of birth, residence, business, length of stay and so on. For two suspects, Sharik Urshukaan and Chaijin Davis, it reveals important facts.

It is important to remember that the Travellers should be the ones to initiate all research. The referee should never volunteer information of this kind.

With a stymied or uncertain group, the referee may use a safety valve to allow their efforts to be channelled in a useful direction as needed. At the referee's discretion, areas of possible research can be suggested to any particular Traveller who makes an Average (8+) INT check. Additional DMs for skill levels in Investigate, Admin or other skills may be added, depending on the avenue of research. Alternatively, a character such as Marja Aguilar may offer a suggestion. Such suggestions should not always be valid directions and should be offered sparingly. They do, however, allow the game to

proceed in times when the Travellers find themselves unable to offer useful courses of action. Of course, a referee offering a hint might consider giving it a cost, such as lost in-game time or escalation by the killer. This may keep the investigation moving forward but also dissuade Travellers from trying to abuse the 'Help Line'.

## Questioning and Character Interaction

One of the most fruitful sources of information and background data is derived from questioning various suspects. Interrogation can bring out a variety of useful bits of information, which can supplement the clues and research results gathered in other ways. Ultimately, it is the Travellers' ability to deal with characters that determines their success in solving the murder.

Each suspect has a unique group of Reaction Values, plus a set of possible reaction modifiers. Each time the suspect is questioned, the Reaction Values are used to regulate the character's attitude and responses. This proceeds along relatively simple lines.

The basic Reaction Value of the suspect is provided in their profile description. This represents the character's outlook and opinion of the Travellers' investigation.

During the questioning session, the Travellers formulate questions to be asked. A roll of 2D is compared to the suspect's Reaction Value. A result equal to or greater than





the value indicates the suspect is cooperative, while a result below this is uncooperative. Reaction modifiers are applied to represent specific questioning conditions or techniques, character quirks and the use of certain skills in the interrogation. Different skills have different effects depending on the suspect. This represents how each suspect should be approached differently.

A cooperative character tells the truth, in so far as he or she knows it. A suspect who is uncooperative may simply refuse to talk, may lie or may threaten or attack the questioners – a specific decision best determined by the referee with a view towards the suspect's nature and the exact situation.

The basic Reaction Value is used for routine questions. When questioning turns to specific areas that the suspect may not wish to discuss freely, other Reaction Values are substituted instead. For example, when questions turn to a discussion of the suspect's background, the background Reaction Value given is used instead of the basic value. Each of the Reaction Values is explained later in this section.

DMs are applied to the rolls made during questioning. These are summed up along with each suspect's reaction information and differs from character-to-character. The referee should decide when specific modifiers should be introduced, based on the Travellers' actions and the overall situation.

In addition to responding to specific questions, suspects may volunteer information, either accidentally or deliberately. Once during each interview with a suspect, the referee should make a special opposed check of the suspect's INT versus their basic Reaction Value. A successful result requires the referee to introduce some new fact into the overall situation. The nature of this revelation – be it personal background, background on some other individual, the confession of some lie previously told, or whatever – is up to the referee.

The other four Reaction Values are explained here.

**Background:** This value is used when questions begin probing into the character's hidden background or motives. A suspect may willingly admit dislike for Urshukaan but does not go into specifics unless this Reaction Value comes into play.

**Knowledge:** This value is used when questions concerning other suspects are brought forward. For example, when Martin Lukargik is questioned concerning Katarin Xuan's history, the Knowledge value is brought into play. Some characters have modifiers applied for their willingness to discuss specific

individuals (e.g. Katarin Xuan and Moshe Srinivasan). If a suspect is indicated as covering for or being in collusion with another, an automatic DM-5 is applied when questions about that suspect come up.

**Confession:** This value is used any time the suspect is directly confronted with evidence and/or an accusation. This may not only be connected with the crime itself; confronting an innocent suspect with the truth of some hidden motive may produce a confession of the details of that motive but a continued claim of innocence. If the suspect is indeed the murderer, DM-3 applied to Confession checks. If the unmodified roll would cause a confession, but the modification prevents it, the murderer confesses to the motive but not to the crime.

A confession can only be demanded twice. The second attempt incurs DM-2. Once those two attempts are made, the suspect sticks to their story. The referee should not impose this restriction in absolute terms on the Traveller ('*No, you cannot ask that again – you've used up all your rolls*'). Rather, it is up to the referee to secretly regulate this aspect of their interaction with the characters. If the Travellers can suddenly produce startling physical evidence or a flawless chain of reasoning pointing to the killer's identity, make a new Confession check but if they are merely bluffing, they get nowhere.

Remember, while a confession does make things easier in catching the killer, it is more important that Inspector Tatsuo Dragovitch believes the evidence the Travellers present, confession or not.

**Alibi:** Another value is used when questioning a suspect's alibi, if the alibi being used is incomplete or false. Successful rolls against the suspect's reactions using this value reveal gaps or inconsistencies that could damage the alibi.

## Other Considerations

When using the character interaction material to set up the crime, additional, special cases may arise. Suspects covering for other suspects may, for instance, falsely confess to the crime or introduce false evidence. This should be handled using the normal confession process but with modifiers introduced at the referee's discretion to assist in the implementation of these false confessions.

**Unexpected Solutions:** The referee must always remain alert for the Traveller or group who approaches the problem in an unexpected or original fashion. Creative ideas – if they are practical – should be rewarded with success or Boon dice to aid in success. There are many possible ideas which could be introduced but not



enough space to cover them all in one adventure. In the end, the referee must deal with such matters. Do not make it too easy to solve the problem. If the Travellers come up with a 'fool-proof' but rather simplistic solution to the crime, complicate things before they have a chance to follow through. Reward creative thought but do not give everything away without making the group work for the solution.

**Evidence:** Strictly speaking, it is not enough for the Travellers to determine the murderer's identity or even a complete account of how the crime was accomplished. They must procure enough evidence (legally obtained) to convince Inspector Dragovitch that a conviction is likely. This is a more difficult matter and is often taken care of in mystery novels by having the killer confess when confronted with detailed knowledge of their acts. Referees wishing to reward a successful solution of the case may use this way out. Another time-honoured method is for the investigator to use their knowledge of the crime to set a trap in which the killer is forced to incriminate themselves, which can make for an exciting denouement. However, the referee chooses to do it (and much depends on what the Travellers think of on their own), the question of sufficient evidence must be addressed.

## DRAMATIS PERSONAE

The following is a brief summary of the major characters and their roles. For statistics and *Known Background*, see *Characters and Opposition* on page 49. For Other Backgrounds, Motive, Means, Alibi and Reaction Values, see individual character profiles found in *Suspects* on page 31.

**Marja Aguilar** – Manager for Arcturus Station Three  
**Inspector Tatsuo Dragovitch** – Police inspector sent from Wainwright Starport  
**Enli Alnasr** – Ringiil Urshukaan's bodyguard

### The Murder Victim

Ringiil Urshukaan – President of Lamarck Minerals, LIC.

### The Suspects

**Katarin Xuan** – Urshukaan's mistress  
**Moshe Srinivasan** – Belter, Katarin's ex-fiancée  
**Sharik Urshukaan (Kashin Thanh)** – Urshukaan's wife  
**Martin Lukargik** – Urshukaan's personal assistant  
**Ooojan M'Banke** – Head of the Independent Belters' Association  
**Bortai Narayanam** – Chief union organiser  
**Eayukheal** – Urshukaan's Aslan security consultant  
**Baronetess Rosa Demetriou** – Former governor of Scaramouche

**Akbar** – The baronetess's loyal servant  
**Chaijin Davis** – Solomani agitator  
**Taril Ulgeev** – Vengeful psion agent

## THE VICTIM

Ringiil Urshukaan was a man with many enemies. A number of people on Arcturus Station Three wanted him dead, for a variety of reasons.

For statistics and public background, see *Characters and Opposition* on page 49. A few specific points require deeper probing to unearth and are listed separately below.

### The Room

It is up to the referee to describe the condition of the suite, based on the method in which the crime was committed. Furniture may or may not be disturbed. Certain factors do remain constant.

A computer terminal is in the large office. In a drawer under the terminal, Urshukaan keeps a body pistol. This pistol is discovered unless the referee designates that it was taken elsewhere.

A bedstand holds Katarin Xuan's dagger in any instance where the dagger has been left in the room but was not the murder weapon (a murderer might also put it back here but this is less likely). A gilded clock of old-fashioned appearance is also located here; it is this clock which may be reset to disguise the time of the murder.

A notebook (see *The Notebook* on page 30) is present somewhere in the suite.

Other clues are up to the referee to locate, using the suspect descriptions and embellishing as desired. Fingerprints and other such obvious clues need not be of any great concern, since even a criminal as slow as Srinivasan would know enough to wear gloves if he were planning a murder. Most prints will be those of perfectly innocent suspects who visited the room with good reason (and need not have been left the night of the crime).

### The Private Files

Urshukaan's private computer files may be used by the referee to provide the Travellers with additional information that they would find difficult to obtain in any other way. Such information may either help to determine the true murderer or expose secret information about another suspect in order to complicate the mystery.



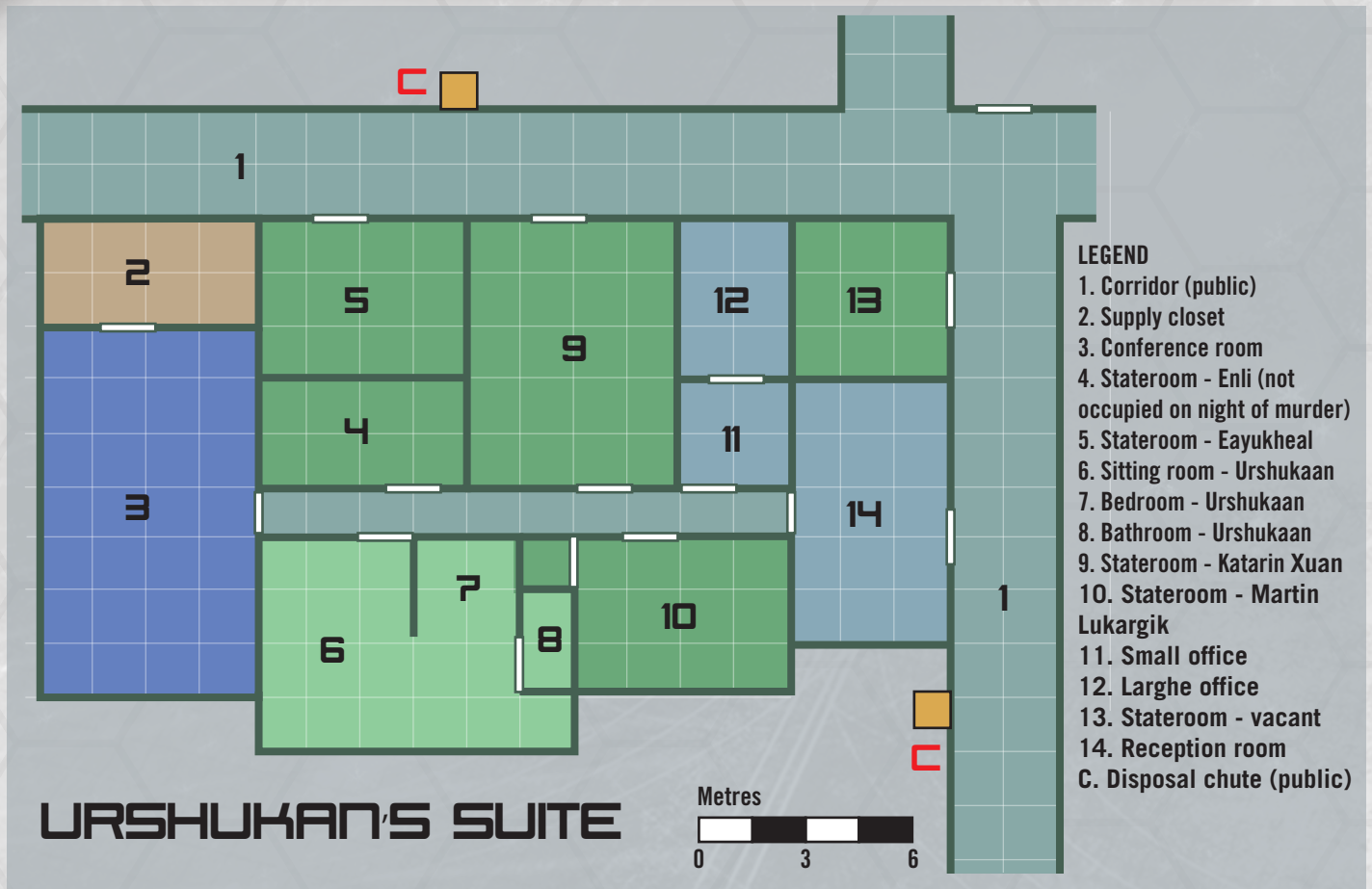

But first, the Travellers must solve another mystery. The Lamarck file system uses a series of passwords to limit employees from accessing restricted files. These are Urshukaan's private files and he was the only person who could access them.

Files are organised into security classifications; to access a file within a certain classification, the user must enter the correct password for that classification. Each classification uses a different password. Urshukaan's files were classified 'Highest Restriction' and only he knew the password.

Most company files use a set, relatively unchanging code; passwords are changed only occasionally. Urshukaan, however, changed his private passwords a great deal, according to Lukargik. He reset the password every time he took up residence in a new office and on a regular basis when at the same office for more than a few weeks.

Accessing the files can be done in two ways. First, the Travellers might simply discover the password Urshukaan was using. Second, a Traveller may hack into his computer with a Very Difficult (12+) Electronics (computers) check (1Dx4 hours, INT).

Lukargik can supply some information; the code word must be between 7 and 10 characters long, must contain only letters (no punctuation marks, spaces and so forth) and must not contain repeated letters. This leaves slightly over  $2 \times 10^{13}$  possibilities, many more than can be tried in the time remaining. Learning this information from Lukargik grants DM+1 on hacking attempts.

### The Notebook

When searching the victim's suite, a notebook is discovered in a secure place, probably not far from the computer terminal. The book contains various random memoranda; dates, cryptic memos and reminders, notes on monetary amounts and so on. It makes dull reading and apparently contains nothing of value.

A Traveller reading the book discovers a key clue if they succeed an Average (8+) Admin check (1Dx10 minutes, INT). One roll allowed each time the book is read through. If the check succeeds, one page is noticed (handout 2), containing a set of entries shown in page 72.



If submitted to rigorous analysis, the following facts are revealed:

1. The left-hand column is Urshukaan's itinerary on his current inspection tour of Lamarck's holdings in the region.
2. The right-hand column is a list of planets and/or subsectors from throughout the Solomani Rim region, in no particular order.
3. Each of these names contains at least seven but no more than 10 letters and none contain duplicated letters.

The list of names, of course, shows Urshukaan's schedule of key words for the security files. By using the word listed next to 'Arcturus', the Travellers can tap into any of the private files.

## Contents of the Files

The following are suggestions for possible contents of Urshukaan's secret files. Not all of these should be used and referees may want to insert other pieces of information, depending on what they wish the Travellers to learn. Bolded headings are the suggested file names discovered when the correct password is entered. For atmosphere, other, irrelevant files may also be included (those having to do with Lamarck business, for example).

**Eayukheal:** Details on all of the Aslan's past history (as given in his suspect description on page 52).

**Ind Belt:** The data given in Ooojan M'Banke's suspect description that Urshukaan was using to blackmail him.

**Narayanam:** Information on the whereabouts, habits and movements of Bortai Narayanam's family on Heraklion.

**Sharik:** Material being collected as a defence against Sharik Urshukaan's lawsuit.

**Demetriou:** A complete record of Urshukaan's successful campaign to remove Baronetess Rosa Demetriou from office. Dossiers on her and her staff (including one on Akbar giving all the information shown in his description on page 59).

**Lukargik:** Information on how Urshukaan has denied promotions to Martin Lukargik for the past two years, despite his stellar employee record and recommendations for advancement.

**L4-M7:** Details on the mining craft which crashed last year. Suppressed reports show the tragedy as the result of faulty drive components that should have been replaced. Hiding this information not only saved the company millions in maintaining its loosened safety standards but also in compensation to the victims' families.

**Omega:** A loose collection of rumours surrounding the suspected individual behind many of the sabotages and other incidents plaguing Lamarck Minerals over the past year, including the recent theft of the Sabre IV.

The name is also associated with rumours of a freelance corporate spy operating across the Solomani Rim. Some reports claim the agent is a psion with the ability to alter their victim's memory.

**Ling-Standard:** A record of correspondence between Urshukaan and the megacorporation, including the job offer and veiled hints of rewards for worthwhile information.

## THE SUSPECTS

See *Creating the Perfect Murder* on page 21 and *Investigating the Crime* on page 26 for information on how the material given here is used. For character details and *Known Background*, see *Characters and Opposition* on page 49.

### 1 KATARIN XUAN

**Involvement:** Katarin is identified in station records as part of Urshukaan's party; she is likely to come to their attention through this. She can also be one of the suspects seen threatening or arguing with Urshukaan before the murder, if desired.

**Other Background:** There are some things Katarin does not freely admit but which may be discovered.

1. Urshukaan had recently decided to drop Xuan and was threatening to leave her, penniless, at Arcturus when the entourage moved on.
2. Katarin's former fiancée, an honest but poor miner named Moshe Srinivasan, is on the station and has seen Katarin several times. Katarin hopes he will help her leave Arcturus and return home.
3. Urshukaan has been beating Katarin and otherwise abusing her, particularly when her demands for attention or money got too strident.

**Motive:** See *Other Background* above. Xuan has seen an opportunity to get free of Urshukaan and knows her devoted Srinivasan will help her out of trouble.

**Means:** The following are the major possibilities covering Katarin Xuan's actions.

### A.

**On the night of the murder, Katarin was summoned by Urshukaan to his quarters.** She may have been seen by casual passers-by en route there but, since she was invited by Urshukaan, she came to the private entrance to his suite, rather than through the reception area. Thus, Lukargik did not see her.

Once in the room, Katarin awaited an opportunity to stab Urshukaan in the back with a dagger she always carried. This dagger is of a type commonly worn by



women on Heraklion, a low Law Level world with a rough reputation. As a part of her upbringing, the wearing of this dagger is as much a part of Katarin's personality as veils to a woman of Arab background on early 20th century Earth.

After killing Urshukaan, Katarin cleaned the knife on Urshukaan's clothing, leaving a stain, and took it with her. Analysis of the blade reveals traces of Urshukaan's blood. Katarin is naturally unwilling to surrender the weapon but would be reluctant to do so even if innocent. Anyone who knows anything about the culture of Heraklion (with an Average (8+) EDU check, or consulting a computer) knows a woman of that culture never willingly surrenders her dagger to anyone.

### **B.**

**Katarin arrives in the room as above. However, she kills Urshukaan by slipping poison into the victim's brandy.**

Katarin obtained the poison at the station dispensary earlier the same day. She visited the dispensary complaining of insomnia and looking to purchase a sleeping medication. During her visit, the pharmacist was called away by a viewphone call, giving Katarin the opportunity to steal a 30ml vial of poisonous chemicals used to deodorise starship air recirculation systems. The chemicals were discovered to be missing sometime after her visit.

If another character is in collusion with her, the viewphone call was made by that accomplice and the pharmacist will recognise the individual again (thus a link discovered between Katarin and another suspect suggests the murder was premeditated). Katarin might, however, have taken the vial on the spur of the moment, taking advantage of her good fortune.

Katarin knew Urshukaan's habits well (as does Lukargik, who can supply information as necessary). Every night, before retiring, Urshukaan always drank a single glass of lunaire, a rare and delicate brandy vacuum-distilled on Earth's moon and appreciated by all connoisseurs of fine spirits. Xuan would not have found it difficult to slip the poison into this carafe, knowing he would drink it at some point.

When Katarin opened the vial, bits of its package seal fell on the floor, to be found by a diligent search of the room. Close examination could verify the packaging is the same as those used on vials from the dispensary. If final proof is needed, the empty vial can be discovered in Katarin's room, or in her possession, or found in a disposal chute with her fingerprints on it. Most of the clues, however, point to her more because of her familiarity with the victim than anything else.

### **C.**

**If Katarin was not the murderer, certain clues may still point her way.**

First, she can be placed in Urshukaan's room by persons having seen her go there and by traces she left during her visit (for instance, Lukargik might notice some of Katarin's favourite wine had been decanted after his last visit to the room and a wine glass with her fingerprints on it might also be found). Clues of this sort are sufficient to place her at the murder scene at some point during the evening.

If the murder was committed with a knife, some false leads may arise. First, her reluctance to surrender her knife will be damaging. It is, however, possible that Katarin no longer has her knife. If, for instance, she made an unsuccessful attempt to attack Urshukaan, he might have taken it away from her. A later visitor to Urshukaan's room might then have used it, either as the first available weapon to come to hand or in a deliberate attempt to implicate Xuan. In the latter case, it would certainly be left in the room to be found. And Xuan would be slow to admit that she allowed the weapon to be taken from her, as this is a very serious offense against Heraklion custom.

If Urshukaan died by poison, Xuan might be implicated again. She might have visited the dispensary to get her medication and been recognised; some other individual could have stolen the chemicals (or they might come from another source entirely).

**Alibi:** Katarin has no solid alibi when first questioned. She claims to have been in her room all night, alone. If Katarin did commit the crime, this unprovable alibi is all she can offer (unless another suspect provides one for her).

### **A.**

It is true. In this case, Katarin was never in the room the night of the murder and only planted evidence points to her as the killer.

### **B.**

Katarin spent part of the evening with Moshe Srinivasan and does not want to involve him (for one thing, his presence gives her a much better motive to kill Urshukaan).

### **C.**

Upset by the loss of her knife (see previous material) Katarin denies having been with Urshukaan at all.

**Reaction Values:** Basic: 8. Background: 10. Knowledge: 6. Alibi: 12. Confession: 14.



### Reaction DMs:

DM-6 if questioning involves loss of her dagger  
DM+2 if interrogators are friendly  
DM-1 if interrogators are hostile  
DM+3 if Katarin perceives a threat to Srinivasan (at referee's option)  
DM+2 if confronted with truth  
DM+2 if surprised (make an opposed INT check to determine if the surprise planned by the Travellers works)  
DM+1 per Cr1000 offered (only for Knowledge check)  
DM-3 to Confession checks if Katarin is the murderer  
The interviewer's Persuade or Streetwise skill level (whichever is higher) acts as a positive DM

**Notes:** Katarin is best used in combination with Moshe Srinivasan.

## **MOSHE SRINIVASAN**

**Involvement:** Moshe Srinivasan is identified as a suspect because of a scene he created at the station before the murder took place. He attempted to force his way into Urshukaan's office, shouting threats and imprecations, and claiming that he would 'kill that cold-blooded krinthoc' (Urshukaan) if he touched her again. This may be one of the **Incident** scenes witnessed by the Travellers.

**Other Background:** Moshe Srinivasan was, in fact, Katarin Xuan's fiancé before she met and went off with Urshukaan. The miner vowed revenge and decided to bring Katarin back. He sold everything he owned for passage to Arcturus (where Katarin told him she was going), plus two tickets for use on the return trip.

Srinivasan has seen Katarin since his arrival at Station Three and she has been manipulating him for her own ends, hoping to escape from Urshukaan's influence.

**Motive:** See *Other Background* above.

**Means:** Moshe Srinivasan is not a particularly devious personality and the basic account of his actions remains a constant. The specific results of these actions, however, can vary considerably.

## **A.**

**Srinivasan forced his way into Urshukaan's suite, demanding Urshukaan let Katarin return to Heraklion with him.** It is possible Katarin urged him to do this and likely Srinivasan gained access to the suite through Katarin's room, which has a separate entrance to the rest of the station that would get Srinivasan in without meeting Lukargik or being subject to possible monitoring by Urshukaan himself.

Once inside, Srinivasan lost his head. He worked himself into a rage and attacked Urshukaan. The ensuing struggle wrecked the room. In the end, Urshukaan was killed. The exact cause of death can be almost anything physical – a blow with a blunt instrument (such as Urshukaan's clock), a slash from a dagger (Katarin's, if Urshukaan took it from her), a gunshot (from Urshukaan's pistol), strangulation or a broken neck. Any of these would account for the death.

Srinivasan is really not bright enough to do much to cover up the crime. When he realised what he had done, he would probably flee. Most of the potential confusion in this situation comes from possible conflicting evidence – misleading clues pointing to M'Banke or Eayukheal, for example.

## **B.**

**Srinivasan is far more useful as a red herring – so obvious that he serves as the perfect shield for the real murderer.**

In this case, the fight goes as above but Urshukaan eventually gets his hands on his pistol and ejects Srinivasan summarily (probably too contemptuous of this bumpkin to even inform corporate security). The room is broken up, however; the real murderer, later, can use the confusing evidence of the fight (and possibly some brief tidying up by Urshukaan) to confuse the traces of the real murder.

**Alibi:** During the fight with Urshukaan, the victim slashed Srinivasan's arm with a knife (Katarin's, if available). The resulting gash required medical attention and Srinivasan went to the dispensary to get it.

If an air-tight alibi is required, one which eliminates Srinivasan from the running entirely, someone will have seen Urshukaan on the viewphone after Srinivasan's attack (possibly requesting a cleaning crew to straighten up the room first thing in the morning). The time of this call occurs after Srinivasan was logged into the dispensary; the body could then be discovered before Srinivasan left.

If Srinivasan is to be left as a suspect, no call from Urshukaan goes in. Later evidence (from other suspects, perhaps) could eventually put the time of the death later than Srinivasan's check-in at the dispensary but the question could remain open for quite some time.

Of course, if Srinivasan is wounded in this fashion, traces of blood on the knife points to him. Again, there is so much evidence of his guilt that Srinivasan is better used as an innocent suspect but an occasional referee might want to make him the killer just to throw off a group of Travellers who feel they need to look at a complicated approach to everything.



**Reaction Values:** Basic: 9. Background: 11. Knowledge: 9. Alibi 12. Confession 14.

**Reaction DMs:**

DM+5 or DM-5 if he perceives that either revealing or concealing something as being in Katarin's interests (referee's option)

DM+5 if confronted by truth

DM-2 for every half-hour of questioning (cumulative, per session)

DM+3 if surprised (make an opposed INT check to determine if the surprise planned by the Travellers works)

DM-3 to Confession checks if Srinivasan is the murderer

The interviewer's Persuade or Leadership skill

(whichever is higher) acts as a positive DM

**Notes:** Moshe needs Katarin around to make a good suspect. It is also wise to include either Sharik Urshukaan or Ooojan M'Banke, each of whom may commit the murder in a way not unlike Srinivasan's. As noted, Srinivasan is a better suspect than he is a murderer.

## **SHARIK URSHUKAAN**

**Involvement:** Sharik's presence at Arcturus Station is not immediately known; she is travelling under an assumed name to avoid harassment from her husband's employees and agents. She is discovered only if her presence is revealed by another suspect who might reasonably know her, especially Lukargik, Eayukheal or Baronetess Rosa Demetriou, or by research into biographical files on Urshukaan – any Traveller succeeding an Average (8+) Investigate check (INT) recognises Sharik from photographs in the file.

**Other Background:** Sharik came to Arcturus Station to obtain evidence for a lawsuit against Urshukaan. When she married him, he had just taken up the post of Commander of Imperial Forces on Scaramouche; she gave up her own career as a merchant officer with Six-Star Services, a local tramp line, to become his wife. About three years ago, they quarrelled and Sharik left her husband. He retaliated by denying her access to money or credit. She is now suing him to recover her half of the property.

**Motive:** Urshukaan never prepared a will and his marriage to Sharik was never dissolved. She stands to inherit most of his holdings as a result.

**Means:** The following options describe the major possible actions undertaken by Sharik.

### **A.**

**With no thought except murder on her mind, Sharik made a surreptitious visit to Urshukaan's suite very late at night.** She almost certainly made sure Martin Lukargik was

not present first, by making a voicephone call to his room. This would ascertain that he was not present if he were already out; if he answered, Sharik would lure him out of the suite with a report of some difficulty in the office complex on the Lower Deck. This call was made using a public station phone near the elevators on the Middle Deck, as the Travellers can discover if they check call records.

Once the assistant was out of the way, Sharik went to Urshukaan's front door, buzzed for admittance and fired several rounds from a silenced body pistol into the victim as he answered the door. The body would have to be pulled back from the door, to allow it to close. Then Sharik departed immediately, disposing of the gun in a convenient disposal chute along the way.

Clues to this crime would be few but, when found, could establish the facts fairly easily. If a search reveals the location of the gun, it is obvious it is the murder weapon. Any Traveller performing a Routine (6+) Gun Combat (slug) check (1Dx10 seconds, INT or EDU) reveals it was recently fired (even if the magazine with several spent rounds is not recovered). More detailed ballistics tests would be required to conclusively prove it is indeed the murder weapon (requiring facilities not available on the station but which are included aboard the Banasdan patrol cruiser en route) but firearms are not discharged on the station often and the match (barring plot complications) would be fairly sure.

The weapon can be traced to Sharik if one of the Travellers thinks to examine the merchant's coveralls someone saw her wearing on the evening of the murder. Spots of oil in one of the garment's pockets match the oil used in the pistol.

If the Travellers are slow on the uptake, the coveralls might also have spots of the victim's blood (splatter from the shot or transferred when the body was moved) – but this is such an obvious clue that it probably should not be used. Another possibility is for the coveralls to turn up, discarded and with both oil and blood stains present, in another disposal chute.

In this case, a six-pointed area that is not as faded as the rest of the coveralls provides a clue; this shoulder patch was that of Six-Star Services, Sharik's former employer. The patch was removed to disguise the outfit but the discoloration still gives it away.

### **B.**

**Sharik, using her assumed name, approached Urshukaan openly, visiting the suite and asking Lukargik for a few minutes with him.** Lukargik escorted her in; Urshukaan, wrapped up in a computer report, ordered the assistant





to bring a file from the Lower Deck office complex. Only after the assistant left did Urshukaan examine his visitor and recognise her. Lukargik might, in this case, have faintly heard him exclaim, 'You! What brings you back to haunt me after all this time'?

Sharik had visited with the honest hope of working out her differences with her husband but he greeted her with abuse and threats. In the course of the encounter, he totally lost control, shouting at her at the top of his lungs and, eventually, physically attacking her. The attack could be with bare hands, with a convenient knife (Katarin Xuan's, if available) or with Urshukaan's own pistol.

Seeking to defend herself, Sharik fought back. In the course of the fight, an accident occurred. The gun went off, the knife found its mark or Urshukaan slipped and fractured his skull against a piece of furniture. In any event, he was dead.

Sharik, realising she could be accused of the crime (and doubting a jury would believe her story, given her motive and the history of her stormy relationship with Urshukaan), made hasty efforts to erase all traces of her presence. Fingerprints could be wiped clean but little could be done to disguise the fact of the murder, or Lukargik's knowledge that Urshukaan had a visitor fitting her description. She might, however, make it look as

if some other party committed the crime. Signs of a struggle could be faked, giving the appearance that the assailant was more physically imposing than she. Sharik might decide to implicate someone else – possibly Xuan – by planting the murder weapon in the other suspect's room. In this case, traces of the weapon's passage (blood from a knife, grease from a gun) would again appear in the pocket of her coveralls. The weapon might then be missed by Lukargik, who could comment on its absence.

This scenario is best used by the referee who wants to cast suspicion plausibly on one of the others, particularly Xuan or Lukargik. In order for times to work out, Lukargik should be delayed in his errand (by anything from a crowded lift to a burglar in the office complex).

**C.** **Sharik could, of course, be innocent. If so, a variant on option B should be used.** Sharik did visit Urshukaan but, instead of a fight, the shouting match resulted in Sharik's rapid ejection from the suite. The real murderer struck after this but Martin Lukargik's testimony about her arrival could keep suspicion focused on Sharik.

In any of the three situations, a distinctive perfume worn by Sharik could be noticed lingering in the room. Travellers might recognise it when they meet her another time with an Average (8+) Investigate or Recon (1D seconds, INT) check.



**Alibi:** Like Katarin Xuan, Sharik does not have much of an alibi. As mentioned, she may pin her hopes, as the murderer, on implicating someone else.

Sharik does not admit to visiting Urshukaan's room, as she is afraid of being tied to the crime (even if she did not do it, she realises her motive is one of the best around). Once Martin Lukargik confirms she was indeed there, Sharik falls back on a stubborn denial that she killed her husband.

**Reaction Values:** Basic: 6. Background: 10. Knowledge: 5. Alibi: 12. Confession: 14.

**Reaction DMs:**

DM-6 as long as her identity remains unknown  
DM+3 if confronted with the truth  
DM+3 if surprised (make an opposed INT check to determine if the surprise planned by the Travellers works)  
DM-2 if interrogators are hostile  
DM-3 to Confession checks if Sharik is the murderer  
The interviewer's Persuade or Streetwise skill (whichever is higher) acts as a positive DM

**Notes:** Sharik is a good, all-purpose suspect. Note that she is capable of opening Urshukaan's electronic doors; information given on this subject can be used to provide an alternate approach to the murder, if desired. If this is done, however, enough clues to sort out one electronics expert from all the others should be present.

As Urshukaan's heir, Sharik is one of the powerful people who should not be offended. Mistreatment or violation of rights causes Sharik Urshukaan to become a powerful enemy in the region (unless she is put behind bars).

#### **4) MARTIN LUKARGIK**

**Involvement:** As Urshukaan's Administrative Assistant, Martin Lukargik is both a prime source of information on the dead man's movements and potential enemies, as well as a good suspect himself. He is certainly the suspect with the greatest access to Urshukaan and must therefore be considered.

**Other Background:** By digging deeper into corporate records, it is discovered that Urshukaan has been responsible for holding back Lukargik's advancement, for purposes unknown. Lukargik has always suspected that Urshukaan wanted to keep him under close observation; as Urshukaan's chief assistant, Lukargik knows more than anyone else about the unscrupulous and often illegal business tactics his employer has used.

**Motive:** Lukargik is dedicated to Lamarck Minerals; everything he has ever done has been for the good of the company. He has recently discovered that Urshukaan

has been skimming off corporate funds for private purposes and entertaining offers of taking a new post with the megacorporation Ling-Standard Products – and, in the process, selling privileged information that would ruin Lamarck. As a result, Lukargik has been torn between protecting company interests and risking the possibility that Urshukaan would ruin his assistant's career before word of the president's plan could get out to stockholders and other concerned parties.

**Means:** One of the following should be used to describe Lukargik's actions of the evening.

The specific method of killing Urshukaan can be quite varied – being poisoned, a gunshot wound or a dagger wound. In any of these cases, see the information given for other suspects for specific potential clues.

With Lukargik as the murderer, the variety comes not so much from the method of the murder but from the ways the assistant attempts to disguise it. A clever man, Lukargik does his best to divert suspicion from himself.

#### **A.**

**Lukargik has free access to his employer and is trusted;** thus, there is little difficulty in murdering Urshukaan by any of the means mentioned before Lukargik then arranges the scene of the murder to make it look as if Urshukaan was killed by some unknown assailant.

In this case, Lukargik plants a large number of clues to mislead the investigation. The exact nature of the clues depends upon the method Lukargik used. A shooting, for instance, would probably be made to look like a break-in and burglary. The suite has been ransacked and valuables have been taken from the room and the victim's body. The victim will have been shot with his own gun, taken from a desk drawer. The weapon has been dropped in the room and a rubber glove is found just outside the private entrance to the room. This door has been forced open. The missing valuables may eventually turn up planted in one of the other suspect's rooms, perhaps even in one of the Travellers' rooms.

#### **B.**

**If poison was used, the method is much like the one described for Katarin Xuan.** Signs in the room point to a visitor having seen Urshukaan; for instance, a cigarette found half-smoked lying next to the flashtray as if it did not quite fall in when tossed there. Station computer records show a pack was ordered that morning through one of the ordering tubes; it is not a brand used by any of the suspects. Two half-filled glasses are found in the room, one of them suspiciously free of fingerprints. Urshukaan's brandy snifter is also found, in the victim's hand; poison was introduced into the brandy



carafe (as with Xuan). Finally, Urshukaan's personal computer terminal service log shows it was accessed with Urshukaan's personal code number for a specific time in the evening, apparently proving Urshukaan was alive and entertaining company at that time.

In fact, the request was made by Lukargik, the only person who would know the password (Xuan might suggest this fact, if questioned). An inconsistency turns up when it is discovered someone – Xuan, a Traveller or one of the other suspects – passing near the victim's room heard a groan and heavy thump about a half hour before the computer call was made. Further inquiry places Lukargik at the dispensary during the day, before the poison turned up missing – the pharmacist remembers Lukargik asking several times for various kinds of anti-nausea medications that were not on the shelves, forcing the pharmacist to check in the back room (a contradiction: Xuan or Urshukaan's bodyguard might innocently drop a reference to 'Old Ironguts'; Lukargik never seemed to suffer from eating spicy foods, motion sickness or any other stomach ailment).

### C.

**If Urshukaan was killed with a knife, Lukargik would probably try to implicate Xuan.** The victim took her knife away from her earlier in the evening (see the description of Katarin Xuan on page 53). Later, Lukargik used the knife on Urshukaan, stabbing him in the back. Knowing Xuan's background, he wiped the knife clean and sent it, via delivery tube, back to her room. She assumed Urshukaan had relented and returned it and would never mention that it was out of her hands. Then, during the inquiry, Lukargik makes sure he is helpful in the investigation, informing the Travellers that Xuan had been in the room and drawing attention to the knife.

The one way to disprove this set-up would be for Xuan to advance a solid alibi (perhaps she was with Srinivasan) which, coupled with the discovery of her cultural background, might lead to a suspicion of Lukargik. The fact he had access to Urshukaan, was one of the only people who could strike from behind, and lied about the time Xuan was present in the room, could well be enough to give the Travellers the leverage to force a confession.

### D.

**If Lukargik is innocent, suspicion might still fall on him in several ways.** First, the fact he is the victim's closest associate makes him a likely suspect. In the case of a gunshot wound, nothing specific points to him; if Urshukaan was poisoned, however, he might well have visited the dispensary (the medicine he wanted was for Urshukaan, not himself). He and Xuan are roughly equal as suspects for a knifing.

Most of the evidence relating to Lukargik, however, comes from motive and background, in addition to material found in the victim's private computer files.

**Alibi:** Lukargik's alibi centres around his work. Through the early part of the evening, he was in the suite, receiving visitors and running occasional errands for Urshukaan (thus he is sometimes gone during noisy confrontations). At 2140 hours, however, he claims Urshukaan dismissed him for the evening. He then went to the office complex to finish work that needed to be done before the next morning. The computers show he logged in at 2144 and remained there until 2305, well after the murder was committed.

If Lukargik did not commit the murder, it occurred during this time frame. If he did, there are two alternate explanations.

**A.**  
**The murder was committed earlier.** In this case, Lukargik filed a room service call using Urshukaan's private code to make it appear he was alive after Lukargik left the suite.

**B.**  
**Lukargik falsified the computer records to show him logged in at a time when he was, in fact, elsewhere – committing the crime.** A Difficult (10+) Electronics (computers) check (1D hours, INT) discovers evidence of the falsified times.

**Reaction Values:** Basic 4. Background: 9. Knowledge: 4. Alibi: 12. Confession: 14.

#### Reaction DMs:

DM+3 if approached 'for the good of the company'  
DM+2 if confronted with the truth  
DM+4 if surprised (make an opposed INT check to determine if the surprise planned by the Travellers works)  
DM-2 if held back from duties  
DM-2 if accused of involvement in murder (as opposed to being asked for help)  
DM-4 if help would reveal company secrets  
DM-3 to Confession checks if Lukargik is the murderer  
The interviewer's Admin or Advocate skill (whichever is higher) acts as a positive DM

**Notes:** Lukargik should always appear, as a source of information if not a suspect. His presence is vitally important.

As a murderer, he tends towards self-righteousness, and is probably one of those fools who would as soon boast about his deed as conceal it. He at least acts inexplicably glad to see his boss dead, one way or another.



## **S** OOJAN M'BANKE

**Involvement:** Oojan M'Banke has been voicing loud threats against Urshukaan for several days, in connection with the failure of M'Banke's attempts to win concessions for the Independent Belters' Association. The Travellers could have witnessed such an outburst as an **Incident** before the murder.

He has a long history of dislike for Urshukaan and over the last day or two has been seen behaving in an uncharacteristic manner – furtive and obviously ill-at-ease.

**Other Background:** M'Banke soon learned the answers to his question as to who called him the Station Three. The message was from Urshukaan. They have met several times since M'Banke arrived, without witnesses; since these meetings began, M'Banke has begun behaving in a secretive fashion. Lukargik knows of the meetings but does not know what was discussed.

**Motive:** Urshukaan was blackmailing M'Banke. Several years ago, while M'Banke was still an independent, he became involved in an actionist movement that was responsible for widespread sabotage in the belt. M'Banke, during one particular operation, accidentally killed three people – one of them the brother of Banasdan's Minister of State – when a bomb he had planted went off early, during an unscheduled inspection tour.

M'Banke escaped detection, buried his past and moved up in IBA political circles to his current position. However Urshukaan's security people have ferreted out this secret; revelation could cause a resounding backlash, which could destroy not only M'Banke's career but everything he has worked for as well.

Urshukaan demanded M'Banke sabotage the new IBA agreement in return for the evidence accumulated against him, plus some incentive – an offer to set up an alternative licensing system that would get the independents a better set of license requirements and fees, but through Lamarck Minerals, to the company's profit.

M'Banke must give in to the blackmail, see his work completely destroyed or see Urshukaan removed.

**Means:** Like Moshe Srinivasan, M'Banke has only one basic story to govern his movements on the night of the murder, but many possible outcomes can derive from this one line of action.

## **A.**

**On the night of the murder, Oojan M'Banke had an appointment to see Urshukaan, during which he gave his final answer regarding Urshukaan's demands.** A note,

either on paper or computer, could be found either in Urshukaan's room or M'Banke's as desired, if a strong clue is needed.

M'Banke proceeded to Urshukaan's room rather late, arriving at a time when Lukargik was out, either on an errand or working elsewhere in the station. Urshukaan admitted M'Banke personally. Inside, the belter expressed his reluctance to betray his cause by sabotaging the new agreement. Urshukaan responded by calling up the file on M'Banke and the IBA on his computer terminal, preparing to transmit the information to several other places, including the Traveller News Service and Marja Aguilar's office. Threatened with this immediate prospect of public exposure, M'Banke grabbed Urshukaan and smashed the terminal. A fight erupted.

As with Moshe Srinivasan, M'Banke could have killed Urshukaan by several methods (almost any direct physical attack – gun, knife, strangulation and so on). Signs of a struggle are evident across the room – smashed furniture, picture frames knocked from the wall, a spilled carafe of brandy.

M'Banke is not as coldly calculating as Sharik but neither is he as stupid as Srinivasan. He knows he must establish an alibi and disguise the fact of his guilt. To do this, he resorts to a simple misdirection, readjusting the time shown by a clock broken in the fight. Wiping clean any fingerprints he may have left, M'Banke then leaves the suite and goes somewhere public, where he is certain to be seen at the time shown on the clock.

This scheme could misfire, either by an early discovery of the tampering (someone finds the body and the clock before the time shown on the face) or a discrepancy between the clock M'Banke changed and another timepiece he was not aware of elsewhere in the room. An Average (8+) Medic check (1D Minutes, EDU) determines the time of death to a half-hour window.

M'Banke's escape from justice depends upon the time factor. He is very specific about times when being interrogated and does everything possible to distract the Travellers from the period when the murder was actually committed. Because there were no other witnesses to this meeting, the proof of the act must come in the form of eliminating other suspects, exploiting discrepancies in M'Banke's story and acting on M'Banke's background and the few clues the Travellers can use to piece together a story.



## B.

**If M'Banke did not commit the crime, he may still have visited the suite.** In this case, he probably gave in to the blackmail, then left to drink somewhere. His visit to Urshukaan's room might be discovered, as above, by the finding of a memorandum; a passer-by might also have seen him going to or coming from his meeting.

If, after he left, there was another visitor who killed Urshukaan and broke up the room (Srinivasan, Sharik, Lukargik), M'Banke would continue as a prime suspect. Proving that he did not kill Urshukaan requires the discovery of more specific evidence pointing to one of these others (perfume and other traces of Sharik's passing; Srinivasan's use of force on the door).

**Alibi:** As discussed previously, M'Banke's alibi depends upon being seen away from the scene of the crime, in public, at the time of the death. The manner in which this works out if he actually committed the murder is explained previously.

**Reaction Values:** Basic: 8. Background: 10. Knowledge: 10. Alibi: 12. Confession: 14.

### Reaction DMs:

DM+6 if confronted by the truth  
DM+3 if surprised (make an opposed INT check to determine if the surprise planned by the Travellers works)  
DM+2 if the Travellers promise not to reveal truth to the public  
DM-4 if interrogators are hostile  
DM-3 to Confession checks if M'Banke is the murderer  
The interviewer's Persuade, Profession (belter) or Streetwise skill (whichever is highest) acts as a positive DM

**Notes:** Oojan M'Banke is another powerful figure, with local influence over independent miners and well-placed friends in the Banasdan government. He is a suspect whose displeasure is to be avoided, according to the station manager.

M'Banke has sufficient Electronics skill to break into Urshukaan's room; he has the resources and knowledge to use a miner's thermal bomb. Either of these two approaches (consult the notes for the Baronetess and Bortai Narayanam) could be used as alternative murder methods if desired.

## B) BORTAI NARAYANAM

**Involvement:** Narayanam has been attempting to meet with Urshukaan for several months. When she finally did so, the day before the murder, she emerged from the meeting nearly incoherent. The only thing she

was clearly heard to say was *'I'll kill him. If he harms them, I'll kill him.'* She may be one of the suspects seen by the Travellers prior to the murder, publicly threatening Urshukaan.

**Other Background:** Delving deep into Bortai Narayanam's background, it is discovered she has two sisters and a brother living on Heraklion, where she was raised. Two of these three work for Lamarck Minerals. Bortai is devoted to them all.

**Motive:** Urshukaan recently decided to put an end to the problem Narayanam posed once and for all. He has informed her that continued union activities among his employees will be met by quick action directed against Bortai's siblings. They will be hurt or killed by some of Urshukaan's hired thugs if the entire union organisation does not quickly disband. He has demanded Bortai turn over a list of the chief union supporters in the Belt, as well.

**Means:** The following summaries delineate the major options for Narayanam's actions.

## A.

**Convinced the only way to protect her family without betraying her cause is to remove Urshukaan, Bortai decides to kill him.** From mining supplies in her ship, she devises an effective murder weapon: a thermal bomb with a simple timer mechanism. Slag charges are extremely common in belter regions (See *Central Supply Catalogue: Arcturus Station* on page 62).

On the night of the murder, Bortai prepared the package, setting the timer for the full hour's delay. She then had a station messenger deliver it to Urshukaan's suite.

A few minutes before the scheduled detonation time, Bortai placed a call to Urshukaan. She told him the information he had requested was in the package and, feigning agitation and concern, begged him to check through it and make sure everything he needed was there. This put Urshukaan into proximity with the bomb at the time of detonation.

When the bomb went off, it generated a great deal of heat but a minimum of shrapnel or blast effects. Investigators note severe charring effects; the body and room are badly burned and most physical evidence has been obliterated. Bits and pieces of the bomb may be recovered, enough for the party to establish that it was, indeed, a thermal device. An Average (8+) Explosives or Profession (belter) check (1D minutes, EDU) identifies the type of explosive and its affiliation to belt mining. Otherwise, the station lab identifies this after 12 hours.





Suspicion should naturally focus on miners; Moshe Srinivasan, Oojan M'Banke and Bortai Narayanam could all have access to the material needed (indeed, the referee should consider this as an alternate means for the first two, although it is rather out of character for Srinivasan). The fact a package was sent to Urshukaan by Narayanam is a matter of record, as is the viewphone call. People who dealt with Narayanam might have noticed she was extremely concerned with time. Most of these clues are more conjectural than solid but could give Travellers a starting point in attempting to break Narayanam's alibi.

### **B.**

**Alternatively, Narayanam may have gone to Urshukaan's suite that evening to deliver the list he demanded.** In this case, after she turned it over, she was appalled when Urshukaan accepted it and then issued fresh demands, again threatening her family.

Like all Heraklionian women, Bortai carries a dagger (hidden in the top of her left boot). Overcome by rage, Bortai pulled this dagger and leaped to the attack, stabbing Urshukaan repeatedly. Only after he was dead did she realise what she had done.

Narayanam proceeded to carefully disguise all trace of her presence. Any tell-tale glasses or other signs of a second person in the room were removed. Fingerprints

were wiped. Narayanam wants the crime to be completely mysterious; an unknown assailant, rather than someone easily connected with the victim in an obvious way.

The most difficult problem is the murder weapon. Although more cosmopolitan in her outlook than Katarin, Bortai is unlikely to readily abandon the weapon, although she probably realises it could incriminate her if examined. If Katarin Xuan's dagger is already in the room, however, an obvious course of action presents itself. The dagger is similar (though not identical) in pattern; since Bortai knows nothing about Katarin, she assumes the dagger belonged to the dead man and could be switched without anyone realising it.

Therefore, Bortai left her own dagger in the room and took Katarin's with her. Later, when examinations take place, Narayanam willingly turns the dagger over for examination, and it would appear she was perfectly innocent.

If Urshukaan and Srinivasan fought that night, however, it might be difficult for Narayanam to explain how Srinivasan's blood came to stain the knife. This might arouse suspicions. If Katarin ever recognises her own blade, it would prove several things – although Katarin's reticent attitude concerning the knife might cause great complications.



## C.

**If Narayanam is innocent, she might still make an excellent suspect as a result of false leads.** For example, if Urshukaan was killed by a bomb, Narayanam might still have sent a package (the actual list Urshukaan demanded) and/or made a viewphone call to him. In a stabbing death, she might have visited him, leaving traces of her passage, and could even have drawn the knife on him and had it taken away, just as was described for Katarin Xuan.

**Alibi:** If a solid, unbreakable alibi is desired, Bortai could have attended a union meeting throughout the evening and been in plain sight the entire time.

In a bombing death, of course, Bortai need never have gone near Urshukaan's suite. However, her movements would require a visit to the station's delivery service within an hour before the bomb exploded and access to a viewphone just before it detonated. The union meeting could still be used, provided she delivered the bomb before her arrival and slipped off to place the call from a public viewphone during the meeting itself. This might be uncovered.

In the stabbing death scenario, her movements that evening would be confusing, with no clear-cut alibi available.

**Reaction Values:** Basic: 5. Background: 10. Knowledge: 7. Alibi: 12. Confession: 14.

### Reaction DMs:

DM+4 if confronted with truth

DM+2 if surprised (make an opposed INT check to determine if the surprise planned by the Travellers works)

DM-2 if Narayanam's knife is taken from her

DM-1 if interrogators are hostile

DM-3 to Confession checks if Bortai is the murderer  
The interviewer's Admin, Profession (belter), or Streetwise skill (whichever is highest) acts as a positive DM

**Notes:** If a bomb is used, at least one other bomb-wielding suspect is required as well.

Narayanam has a great deal of political influence by virtue of her position and should not be offended.

With Jack-of-All-Trades 3, Narayanam could, if desired, gain access to Urshukaan by opening electronically locked doors (see the Baronetess's description on page 59). This may be introduced as an alternative approach to committing the crime.

## P>> EAYUKHEAL

**Involvement:** Eayukheal, an Aslan army officer who served with Urshukaan years ago, has met with him several times on Station Three, apparently in connection with some urgent personal problem. Urshukaan was heard telling the Aslan, *'You made your mistake and now you'll live with it. You're mine for as long as I care to use you. Your family will see to that.'* These words were uttered only hours before Urshukaan's body was found and may have been one of the **Incidents** observed by the Travellers.

**Other Background:** An obscure bit of data, known only from Urshukaan's private files, is central to Eayukheal's history.

In the early stages of the conflict on Scaramouche, Urshukaan saved Eayukheal's life. The Aslan swore a solemn oath to his superior, to protect him from all harm and follow him as one of Urshukaan's own clan. A few weeks later, in another action, Eayukheal was put to a supreme test. The Aslan's cousin, a lieutenant, was wounded. Eayukheal set out to rescue him. As he was crawling to the lieutenant's position and reached a point half-way between the command post and the wounded officer's foxhole, he heard Urshukaan calling. Rebel troops were rushing the command post and the general was in danger. Caught between conflicting responsibilities – to his cousin and to Urshukaan – Eayukheal chose to rescue the wounded Aslan.

Urshukaan and the handful of men with him managed to hold off the rebels until relief came but Eayukheal had been shamed, dishonoured by his failure to discharge his responsibility to Urshukaan. The general threatened to make this shame public, bringing the same dishonour down upon the Aslan's family, unless Eayukheal obeyed the general completely, in all things, from that time on.

Lukargik can supply information on more recent events.

Since joining Lamarck Minerals, Urshukaan has employed Eayukheal to carry out dirty jobs, those involving force and blackmail against rivals, still under threat of revealing the Aslan's secret. Urshukaan even vowed to release the secret if Eayukheal killed himself. Recently, however, Urshukaan asked more than Eayukheal can deliver – he demanded the Aslan take steps to discredit a rival minerals firm – a firm in which the Aslan's sister is an important executive. Carrying out the orders means the ruin of his sister and even greater dishonour.

**Motive:** Eayukheal has tried, without success, to get free of Urshukaan. The man's death is the only way out. But Eayukheal cannot allow the truth of the crime to come



out (or his family suffers the disgrace); nor can he take his own life, despite his tormenter being dead, until he discovers whether or not Urshukaan left some record of the secret behind.

**Means:** If Eayukheal is involved in the crime, one of the following explanations of events is used.

**A.**

**The Aslan visited Urshukaan on the night of the murder to plead again to be released from the victim's latest set of orders.** When Urshukaan refused, the Aslan slashed him across the throat with his dewclaw, killing him.

**B.**

**As above, except Eayukheal seized him and broke his neck.** In this case, an investigator with Medic skill discovers several unusual signs on the victim's body.

1. The neck is not just broken; it is dislocated by being pushed up and back with great force.
2. The victim's jaw has been similarly dislocated.
3. There is a scratch – possibly deep – running vertically between the victim's temple and right eye.

These signs were left by the attack, which involved the Aslan placing his hand under the victim's chin and pushing back and up with great force. It is a blow that takes great physical strength and leverage, and would be unlikely for most humans. The scratch comes from the dewclaw, which rested across the victim's face when the shove was delivered.

In either of these two forms of attack, there are few other clues to be found. Above all other things, it is the behaviour of the Aslan that is the strongest clue and the Aslan reputation that provides the strongest counterbalance against any presumption of guilt.

After the murder, Eayukheal attempts to gain access to Urshukaan's computer files. He is most likely prevented from this at the time of the murder by the return of Lukargik to the reception area from some errand. Eayukheal would slip out of the private entrance.

The Aslan continues to seek out those files. Later clues might include an attempted break-in in the office complex, demands or threats against Lukargik for access to the files and so forth. If Eayukheal gets access to the files, he destroys them and then settles into a final period of meditation leading up to a ritual suicide. As long as the files may still be uncovered, he postpones the suicide in the hopes of recovering them and thus sparing his family the shame of his past.

**C.**

**If Eayukheal is innocent of the crime, there is no physical evidence implicating him.** His behaviour, however, is suspicious – in fact, many of the same actions connected with the search for Urshukaan's computer records still occur one way or the other. The Aslan does not want those facts to come out. He does everything he can to recover the files before killing himself.

It may be that he succeeds in his purpose, thus apparently proving himself the killer. Other evidence might turn up to conflict with this, however. The discovery of what really motivated Eayukheal help the Travellers fix the blame on another party and clear up these discrepancies.

Travellers may be disinclined to suspect the Aslan, thinking it out of character for him to kill and then not admit it. In Eayukheal's case, however, the need to suppress the truth of his own dishonour outweighs this aspect and makes it likely that his behaviour comes as a surprise – albeit a reasonable one – to the investigating Travellers.

**Alibi:** When questioned, Eayukheal is sullen and uncooperative. Whether he is guilty or innocent, his answer is 'I did not kill him. I will say no more.' Since most people who know anything about the Aslan may assume him incapable of lying, this is sufficient to convince many of his innocence. If he is guilty, the lie is sparked by his need to spare his family from dishonour. Further questioning yields nothing.

A possible alibi the referee may wish to allow places Eayukheal in the Lamarck Minerals computer room at the time of the murder, attempting to tap into the private files and erase the information there. He might be seen by someone else (a security guard or Lukargik) and thus, given a solid alibi, despite him refusing to discuss matters himself. As he would not want Urshukaan to know he was there, the Aslan would have been quite secretive in this visit and might even have attacked someone discovered in the room from behind in order to make the break-in. All of this could generally be used to increase the uncertainty and mystery of a situation in which Eayukheal was not the killer.

**Reaction Values:** Eayukheal does not use reaction rolls. Consult the information before for his behaviour.

**Notes:** To use Eayukheal, the referee should be familiar with the character of the Aslan culture. If he is used, be sure to make it is clear he is following Aslan precepts of honour and ethics. One point of common knowledge is that an Aslan would not use a knife as a weapon, although the dewclaw might leave a wound difficult to distinguish from a knife wound.



## **B** BARONETESS ROSA DEMETRIOU

**Involvement:** The Baronetess, a noble who has been stranded at Arcturus Station Three for several weeks by the breakdown of her yacht's navigational computer, met Urshukaan accidentally in a public promenade of the station. In response to some unctuous greeting by Urshukaan, she was heard to say, *'Of all the dirty Stinkscrabblers I might have met, of course it had to be you. Why don't you crawl in some hole, before one of your victims has sense enough to pay you back – in full!'* This encounter could be one of the **Incidents** witnessed by the Travellers.

**Other Background:** It was Urshukaan, acting through agents, who was responsible for the charges brought against the Baronetess (which were supported by carefully faked evidence). This was done by way of revenge for her part in his own fall from grace. One of Urshukaan's private files describes this elaborate plot.

**Motive:** The Baronetess always knew, but could never prove, Urshukaan was behind her downfall. An intensely ambitious woman with a burning desire to serve the Imperium, Demetriou found herself an outcast and has grown increasingly bitter as the years passed. It would not take much for her to act out her deepest desire of bestowing on Urshukaan the final punishment for his past misdeeds.

**Means:** The Baronetess's actions follow one of the courses outlined below.

### **A.**

**Having conceived the notion of killing Urshukaan, the Baronetess turned to one of her entourage for assistance.**

This was Akbar, a former Scaramouche rebel who was pardoned by Demetriou and became her devoted servant. Akbar, a man of many talents, was able to assist her in formulating a plan of action.

Akbar was able to steal plastic explosives from the station warehouses (see the description of Chaijin Davis on page 61) and use them to assemble a small bomb. At some time prior to Urshukaan's arrival in his room, Akbar gained entrance to the suite, planted the bomb under the victim's bed and left again. The timer for this bomb, like that described for Davis, could be set up for up to 12 hours' delay.

Using his knowledge of electronics, Akbar tampered with electronic locks to gain access where needed. Signs of the tampering are plain to anyone with the Electronics skill who examines the door mechanisms. The burglary of the warehouse could be carried out in the same way.

Connecting Akbar to the crime is not easy. If, however, the choice can be narrowed to, say, Akbar and Davis (by alibis or by other means), the discovery of a dossier on Akbar in Urshukaan's private files reveals he has the knowledge to get past the electronic locks, while Davis does not. This file also shows Akbar was suspected of complicity in the assassination of Urshukaan's predecessor as governor – an assassination performed using a bomb similar in fashion to this one.

The Baronetess is, of course, shielded by Akbar and he could indeed be used as a suspect separate and apart from her. If her complicity is desired and some stronger connection warranted, it is suggested that Demetriou actively provides an alibi for Akbar. Since she is thus protecting him, her involvement in the crime is obvious.

### **B.**

**Again, Akbar and Demetriou work together but in this version, the Baronetess takes a more active role in the murder.**

Akbar uses his skill with locks to get both of them into the suite on the night of the murder. Once inside, one of two methods – a body pistol or dagger – could be used to do the deed. The Baronetess is more likely to use the pistol, as she is an excellent shot; Akbar is most likely to cut the victim's throat.

This version of the murder makes use of all standard clues – the murder weapon is dropped in a disposal chute, as well as any bloodstained clothes. Grease markings on the Baronetess's clothing would match with her pistol. Akbar's dagger is of a type made only on Scaramouche and used as an unofficial symbol of the Solomani rebels. This clue could point to Davis or Akbar as rebels, or to Demetriou or Urshukaan himself if it were a prize of some kind.

For traditionalists, a pearl or other small personal item could be lost by the Baronetess during her visit and discovered through a thorough investigation of the suite. This missing item could later be connected to her, but is a blatant clue.

### **C.**

**It is more likely, if the Baronetess did not commit the crime, that she was nowhere near the room, so circumstantial evidence will probably not point to her or to Akbar.** If she committed the crime, the referee should obscure the trail with other suspects; if she did not, most suspicion should attach to her because of motive and because of her highly uncooperative attitude. Furious at even being suspected, the innocent Baronetess displays many of the hallmarks of a guilty party.



Finally, someone might plant clues pointing to her in an effort to provide false leads. A stolen piece of her jewellery could be deliberately planted in the suite or the murder weapon hidden in her room. Thus, if the Baronetess did not do it, she can best be made a valid suspect by some conscious plot on the part of the murderer.

The most likely candidates for this action are Martin Lukargik and Chaijin Davis.

**Alibi:** Demetriou's alibi is provided by members of her own staff. Several claim to have been with her, or to have spoken by viewphone, at various times, giving her a nearly continuous alibi for the entire evening.

If the Baronetess committed the crime, one or more of these servants are not telling the truth. Close questioning and cross-examination by the Travellers reveals inconsistencies in the stories told on an Average (8+) Advocate, Deception, Persuade or Streetwise check (1Dx10 minutes, INT). Inconsistencies do not necessarily mean her alibi is untrue (and can turn up even if the Baronetess is innocent) but certainly encourages further investigation.

If Akbar's bomb was used, no alibi can cover the entire 12-hour period prior to the death. Collaboration between Akbar and Demetriou may be pointed up by Akbar's alibi for some specific time – say the period of the warehouse break-in – being given by the Baronetess alone.

**Reaction Values:** Basic: 7. Background: 10. Knowledge: 10. Alibi: 12. Confession: 14.

#### Reaction DMs:

DM+6 if confronted with the truth  
DM+2 if given the evidence from Urshukaan's files, proving her innocence in the corruption scandal  
DM+5 if surprised (make an opposed INT check to determine if the surprise planned by the Travellers works)  
DM+3 if deference is shown to her rank  
DM-1 per half hour of questioning or detention (cumulative, per session)  
DM-3 to Confession checks if Demetriou is the murderer  
Each point of the interviewer's SOC below hers (12) acts as a negative DM  
The interviewer's Admin or Steward skill (whichever is higher) acts as a positive DM

**Notes:** The use of the Baronetess also requires the introduction of her servant Akbar (see *Characters and Opposition*, on page 49). The rest of her staff may be used as the referee desires.

#### Baronetess's Staff:

1. Akbar, 46. Human. Servant.  
The Baronetess's mute servant and bodyguard rarely leaves her side. He uses Demetriou's reaction rules.
2. Frantin Xlay, 35. Human. Secretary.  
Frantin has served as the Baronetess's personal secretary for seven years. She possesses a keen attention to detail and keeps thorough records of appointments and notes in her portable computer. These may support or refute Demetriou's alibi.
3. Mattin Leoud, 42. Human. Chef.  
Short and lean with a slender moustache, Mattin has served as the Baronetess's personal chef for four years. He strums his fingers when nervous.
4. Joyset Ilan, 23. Human. Maid.  
The youngest of the servants, Joyset has worked as the Baronetess's maid for one year. Her black hair is usually tied in a tight bun and her brown eyes are large and expressive.

The Baronetess obviously has much power and influence, and should be treated with great care and caution.

#### CHAIJIN DAVIS

**Involvement:** Davis would not, normally, be suspected at all, except for a single incident. In a bar the night before the murder, Davis got extremely drunk and was heard uttering loud but rather incoherent threats against Urshukaan, promising vengeance for '*our comrades slaughtered by the Impie pig*'. Several station administrative personnel heard him and brought him to Aguilar's attention after Urshukaan was found dead.

**Other Background:** A detailed survey of the rebellion on Scaramouche notes that Party resistance was considerably hampered following the arrest of Moradeyo Atiyah, one of the rallying points of the movement, during Acting-Governor Urshukaan's first proclamation of martial law.

Chaijin Davis is Moradeyo Atiyah's son, travelling under her maiden name to avoid being connected to the heroine of the Scaramouche uprisings. He hates the Imperium, being a staunch member of an extremist Solomani group that advocates the use of terrorist tactics to win back Solomani freedom.

**Motive:** Most especially, Chaijin wants to kill the man responsible for crushing the rebellion on Scaramouche and killing both his parents (his mother died in prison and his father was killed in the fighting).

**Means:** The actions of Chaijin Davis at the time of the murder can be drawn from one of the options presented below.



## A.

**When Davis became aware Urshukaan was on the station, he set out to build himself a small bomb.** Using some contacts, he learned various companies store explosives at the station for use by miners. A forged maintenance worker's pass and some stolen coveralls allowed him to steal some plastic explosive, enough to build a small (one kilogram) bomb. A great deal of shrapnel – screws, ball bearings and other sharp objects. – was added as well, making it an excellent terrorist's anti-personnel bomb. The detonator was a simple electrical timer; Davis has had plenty of exposure to this sort of weapon and assembled it easily.

Using the same maintenance worker's pass and coveralls, Davis then brought the device, concealed in a tool kit, to the victim's quarters. While pretending to check up on a problem with the viewphone system, Davis set the bomb in Urshukaan's quarters, in such a way as to do the maximum possible damage. This might have been done at almost any time up to 12 hours before the explosion; it will be difficult to chart the suspect's movements over the whole time.

Nonetheless, a passer-by may have noticed a repairman entering the suite at some point (and station records do not show any personnel assigned to work in the suite that day); his presence might be more forcibly brought home by Lukargik's mentioning that some tools discovered in the room belonged to the repairman sent to check the viewphone that afternoon.

In building a case against Davis, most of the clues come from tracing the missing explosives to him. Routine legwork can establish a description of the repairman, which should rule out several other suspects; when this tallies with the description of the maintenance worker who was in the storage areas before the explosives turned up missing and Davis's history as an amateur terrorist is uncovered, a good working base of evidence (albeit circumstantial) becomes available. And, as the reaction information shows, Davis is boastful and vain enough to be tricked into a confession with a little effort.

## B.

**Another method of murder is somewhat more direct.**

Davis, again disguised as a repairman, gained access to the suite on the night of the murder. He came to Urshukaan's door, buzzed for admittance and shot the victim once in the stomach when the door opened. Dragging the wounded man away from the door, Davis then spent several minutes reminding Urshukaan of his background, of his dead parents and of the inevitability

of Solomani triumph over Impie slime and weakling Vilani degenerates. His tirade over, he placed the gun against the victim's head and executed him.

This killing creates a lot of blood, and there are ample chances for bloodstains to turn up on the killer's shoes, clothes and other personal effects. Most of these items would probably go into a disposal chute but there might be an overlooked item or two that can be discovered by a careful search. One possibility would be two photographs, of Davis's parents, which Davis had out as part of his show-and-tell session before the execution.

The style of the killing is most in-keeping with the political terrorist approach. Most of the other suspects are unlikely to have acted in so cold-blooded a fashion. By and large, the shooting cases revolve either around an accident or an act of passion. This one might stand out for that reason.

It is also possible the victim himself can provide some clue to his killer's identity, in the best tradition of detective fiction. A symbol drawn in blood on the floor as he listened to Davis rave could have no special significance, unless research into the background of Scaramouche and the rebellion revealed it to be the symbol of the Scaramouche rebels.

## C.

**If Davis is not the killer, circumstantial evidence still points his way.** He is the sort of obvious killer (much like Srinivasan) who makes a superb red herring.

**Alibi:** Davis is unlikely to have an effective alibi. If the need arises for one, he can have been seen in a public place (the casino for instance) at the time of the killing (if the murder was a shooting). If a bomb was used, it is virtually impossible for him to have a full alibi for the entire period.

**Reaction Values:** Basic: 9. Background: 12. Knowledge: 12. Alibi: 14. Confession: 14.

### Reaction DMs:

DM+6 if confronted with truth

DM+4 if surprised (make an opposed INT check to determine if the surprise planned by the Travellers works)

DM+2 if questioner is Solomani

DM+2 if questioner seems sympathetic to Solomani cause

DM-3 if questioner is Vilani or non-human

DM-2 if questioner is hostile

DM-3 to Confession checks if Davis is the murderer

The interviewer's Leadership or Streetwise skill (whichever is greater) acts as a positive DM





**Notes:** For more details on the Solomani unrest on Scaramouche, see *Library Data* on page 61.

## 10 >> TARIL ULGEEV

**Involvement:** Taril's presence at Arcturus Station is not outwardly suspicious. She is discovered if recognised by another suspect, especially Martin Lukargik, Eayukheal or Bortai Narayanam, or by research into files on the L4-M7 accident – any Traveller succeeding an Average (8+) Investigate check (INT) recognises Taril from a news report interviewing the victims' families. Taril was extremely vocal in her accusations of Lamarck Minerals covering up their responsibility.

**Other Background:** Taril is the younger sister of Perdal Ulgeev, the engineer killed aboard the L4-M7 mining craft. While she has never been able to prove it, Taril is convinced the crash was the result of Urshukaan loosening company safety protocols. There are several more details about her which she does not freely admit to.

1. Taril is a psionic agent, selling her services to various corporations and governments. Given the Imperial ban on psionics, she never discloses to her clients how she achieves her results.

2. Under the alias Omega, Taril orchestrated the attempted theft of the ore carrier Sabre IV. In addition to the fortune she intended to make from the heist, she hoped the financial loss and embarrassment would bring the end to Urshukaan's tenure as company president.

**Motive:** With the failure to steal the ore carrier, Taril decided to take a more direct approach in her revenge.

**Means:** The following are the major possibilities covering Taril Ulgeev's actions.

### A.

**After learning of the Travellers' involvement in recovering the ore carrier, and the denied payment for their actions, Taril found the perfect opportunity to expand her revenge.** Instead of killing Urshukaan herself, she would have a Traveller do it for her.

The night of the murder, she approached a lone Traveller in the station's bar. After striking up a brief conversation with them, Taril used her telepathic powers to implant a suggestion into the Traveller's mind. It was not difficult, given the Traveller's recent dealings with Urshukaan. The Traveller left the bar, went upstairs to Urshukaan's



suite, knocked and when he opened the door, the Traveller murdered him. How the crime was committed – shooting, stabbing and so forth – is up to the referee, depending on the specific Traveller's skills and available weapons. The deed complete, the Traveller returned to the bar where, using her Mind Wipe ability, Taril removed the entire incident from the Traveller's memory. The whole affair took less than six minutes. Taril spent the rest of the evening in the casino.

The Traveller, therefore, is unaware they are the murderer. If they discarded their weapon in a disposal chute after the crime, they may initially notice their weapon is missing when Marja Agular informs them of Urshukaan's death. Later, they may discover it stained with Urshukaan's blood or recently fired. There may be other incriminating clues at the crime scene such as fingerprints or witness testimony from a passer-by who saw the Traveller knocking on the victim's door at the time of the crime.

If Agular learns of the Traveller's involvement, she immediately arrests them unless the Travellers can convince her otherwise. This may be assisted if the framed Traveller volunteers to be subjected to a stress detector. If Agular learns the Traveller intentionally hid any evidence of their own involvement, she cannot be swayed into believing their innocence until a suitable explanation is provided.

Proving the Traveller's innocence is difficult but not impossible. Reviewing the casino cameras shows the Traveller at the bar, speaking with Taril before leaving and then returning. The Traveller's memory of the incident may only recall the exchange as lasting seconds, rather than minutes.

The biggest hint as to how this was accomplished is found in Urshukaan's private files on Omega. In them is the rumour that the mysterious agent is a psion capable of altering their victim's memory. The next step, of course, is discovering who Omega is.

Taril's computer contains records of her correspondences with Captain Hart Fonroe, who stole the ore carrier. They are signed as Omega. She will not offer her password. It requires a Difficult (10+) Electronics (computers) check (1Dx4 hours) to hack her computer.

Proving she is a psion can be more difficult. The station lacks a psionic detector and the ones belonging to the Banasdan Port Authority are large, slow and impossible to use without the subject knowing they are being tested. Banasdan Law requires probable

cause before a test can be administered without the subject's consent. Outside of a confession, the only other evidence suggesting Taril possesses psionic abilities is the emergency dose of psi-drug hidden on her person. She may attempt to destroy this evidence if she knows suspicion has fallen on her – a feat made easier through her telepathic ability.

Of course, proving she is a psion or Omega does not prove the Traveller's innocence in the murder. Enough evidence must still be mounted to convince Inspector Tatsuo Dragovitch of the truth.

## **B.**

**If Taril is used, and not the killer, evidence may still suggest her guilt.** Her role in both the ore carrier's theft and her crime of being a psion in Imperial space may point enough evidence against her that the real killer might escape.

**Alibi:** Whether Taril was the murderer or not, she spent the evening enjoying the casino and bar. Witnesses and security footage corroborate her story. She freely admits to a brief conversation with the Traveller in which they left and later returned from, thus shifting suspicion back onto the Traveller.

**Reaction Values:** Basic: 10. Background: 14. Knowledge: 12. Alibi: 8. Confession: 14.

### **Reaction DMs:**

DM+6 if confronted with truth

DM+4 if given evidence the L4-M7 accident was not due to pilot error

DM+2 if surprised (make an opposed INT check to determine if the surprise planned by the Travellers works)

DM+2 if given psionic inhibitor drug

DM-6 as long as her identity is unknown

DM-2 if questioner is hostile

DM-3 to Confession checks if Taril is the murderer

The interviewer's Persuade or Streetwise skill (whichever is greater) acts as a positive DM

**Notes:** Psionic inhibitor drugs are not readily available aboard Station Three but can be manufactured by the dispensary in 24 hours. There are inhibitor drugs aboard Inspector Dragovitch's ship when it arrives.

## **GENERAL NOTES**

Naturally, a great deal of latitude has been left in the suspect descriptions; there are many areas still to be filled in. This is up to the referee, based on the exact scenario being cooked up to test Traveller skill.



When setting up the mystery, consider how the murder is to have taken place and determine additional clues of possible use from this. For instance, the arrangement of the victim's body can be a powerful indicator. If killed by Baronetess Rosa Demetriou after a surreptitious entrance to the suite, the body is more likely to be found in a position indicating relaxation or repose. This is highly unlikely if Moshe Srinivasan killed him, since Moshe is not the sort who could easily sneak up on his victim.

The referee should feel free (even encouraged) to go beyond these descriptions. Several characters have the Electronics skills needed for a break-in, so Akbar is not the only one who could unlock doors and make a stealthy approach. Chaijin Davis might just as well use a knife or possibly a pistol and knife in combination (belly shot to immobilise, slit throat to kill). Sharik Urshukaan might have slipped in long before the time of death and poisoned the brandy, knowing her husband's partiality to it.

When coming up with some original approach, make sure the mystery is consistent with the character. (How would Katarin use a bomb? How could Demetriou know enough to poison the right bottle?) Then make sure enough clues are provided to allow the mystery to be solved. Enough confusion should be available to keep the Travellers uncertain for a time but there must be a single solution that satisfactorily explains all the clues – one which sufficient detective work will uncover. Some of these may rely on confessions or other interrogative actions but no murder should be completely insoluble.

## REFEREE'S NOTES

*Murder on Arcturus Station* is quite unlike any other adventure ever undertaken and provides a great deal of flexibility. Of course, this is won only at the cost of

something else – in this case, the referee is burdened by a great deal of work not usually necessary in preparing to run a published *Traveller* adventure.

Nonetheless, the rewards should be obvious. As referee, you control many things that prepared adventures do not usually let you control – the complexity, the solution, even the exact nature of character interaction. This adventure will not appeal to everyone but we feel it will suit a great many who have the creativity to develop an adventure but not the time to fit all the details together.

The adventure is not meant to be taken as gospel. We often stress the fact that referees should tinker with their material as they wish. This time, we insist. A great many things have been done to allow multiple playthroughs and variable situations; but there are still many elements left which, once revealed, spoil the 'surprise' aspect of the mystery. Tamper with these: add new suspects; set up a brand-new murder; draw from classic literary and movie sources for more complicated plots and more intricate solutions.

One other possibility is to dispense with your usual Travellers and use the suspects as the Travellers themselves. Give each the information on Katarin Xuan, Eayukheal and the others, and have them play those roles; of course, one of them will be the murderer, and the section *A Traveller as Murderer* on page 24, should be consulted here. In this case, Aguilar and Dragovitch (also the Travellers) should have the main responsibility for solving the crime but other Travellers may help as they see fit. This option calls for roleplaying in the most complete sense of the term.

We have only skimmed the surface of the possibilities. It is up to you to explore them further.

The game's afoot!



# CHARACTERS AND OPPOSITION

The material presented here is the statistics for the major characters. Some appear in both adventures. The Known Background information represents what is commonly known about those characters, as general knowledge or through research into computer records conducted by the Travellers as they begin their investigations. Deeper or hidden information may be uncovered on some.

## Mind Wipe

The telepath removes the previous few minutes from a subject's memory. To the subject, no time has passed between the present and the moment they last remembered. This can be jarring to a subject suddenly finding themselves in a new location, having no memory as to how they arrived there. Psions wishing to conceal the fact a subject's memory was removed, try to place the subject in the same location as they were at the time of their last recollection. For every point of Effect, the psion may remove D3 minutes from their subject's memory.

**Check:** Very Difficult (12+) Telepathy check (1Dx10 seconds, PSI)

**Reach:** Short

**PSI Cost:** 5

## STATION SECURITY OFFICERS Corporate Enforcement Personnel

SPECIES		GENDER		AGE	
—		—		—	
TRAITS				—	
STR	9	INT	8	SKILLS	
DEX	7	EDU	6	Electronics (computers) 1, Gun	
END	8	SOC	6	Combat (slug) 1, Melee (unarmed) 2,	
PSI	—			Recon 1, Streetwise 1	
WEAPONS		Autopistol (3D-3), Stunstick (2D)			
ARMOUR		Mesh (+2)			
EQUIPMENT		Mobile Comm			

## KNOWN BACKGROUND:

Employed by Lamarck Minerals, LIC, these security officers serve as Station Three's modest police force. While required to uphold Banasdan Law and follow Marja Aguilar's direction, their loyalty is to their employer. The majority of their duties are protecting station and company property, handling thefts, disorderly conducts and domestic crimes. During confrontations, they are far more likely to subdue rather than employ deadly force.



## MARJA AGUILAR, Station Manager for Arcturus Station Three

SPECIES		GENDER		AGE
Human		Female		38
TRAITS				
STR	6	INT	4	SKILLS
DEX	8	EDU	10	
END	7	SOC	8	
PSI	—			
Admin 4, Electronics (computers) 3, Gun Combat (energy) 2, Jack-of-all-Trades 1, Leadership 1				
WEAPONS		Stunner (3D)		
EQUIPMENT		Mobile Comm		

### KNOWN BACKGROUND:

Aguilar, as station manager, is a relatively influential friend. She is also, however, a representative of the Banasdan government first and foremost. Aguilar is extremely unlikely to countenance anything illegal or unethical in the Travellers' investigation. If they attempt to ignore her wishes in this area (and she



will become aware of such things as unauthorised use of truth serum or stress detection gear), she almost certainly reports it. Friend although she may be, she has responsibilities and a job of her own to think about.

## INSPECTOR TATSUO DRAGOVITCH Police Inspector sent from Wainwright Starport

SPECIES		GENDER		AGE
Human		Male		34
TRAITS				
STR	10	INT	5	SKILLS
DEX	11	EDU	6	
END	9	SOC	6	
PSI	—			
Electronics (computers) 2, Gambler 1, Gun Combat (slug) 2, Melee (unarmed) 2, Investigate 2, Recon 1, Tactics (military) 2				
WEAPONS		Autopistol (3D-3)		
ARMOUR		Jack (+1)		
EQUIPMENT		Mobile Comm		

### KNOWN BACKGROUND:

A former army captain, Dragovitch is the police inspector assigned to investigate Ringiil Urshukaan's murder. On his arrival, he proves to be everything Marja Aguilar said he would be (see *Death on Station Three*, on page 18). He dislikes



bands of Travellers on principle and is only too happy to detain them if he feels they have exceeded their authority or if someone with influence (Aguilar, Oojan M'Banke, Bortai Narayanam, Sharik Urshukaan or Baronetess Rosa Demetriou) accuses them of any sort of impropriety.



# RINGIIL URSHUKAAN

## President of Lamarck Minerals, LIC

SPECIES		GENDER		AGE
Human		Male		54
TRAITS				
STR	7	INT	10	SKILLS
DEX	5	EDU	10	Admin 4,
END	8	SOC	9	Electronics (computers) 4,
PSI	—			Gambler 1,
				Gun Combat (slug) 1,
				Leadership 2,
				Tactics (military) 1
WEAPONS		Body Pistol (2D)		
EQUIPMENT		Mobile Comm		



### KNOWN BACKGROUND:

An army officer of some local fame, Urshukaan rose to command Imperial forces engaged against Solomani rebels during the Unity Uprisings on Scaramouche in the Harlequin subsector of the Solomani Rim. Although his forces suffered several reverses in the early stages of the campaign, the general eventually subdued the worst outbreaks of armed resistance. On the assassination of the Imperial Governor of the planet, Urshukaan was named Acting Governor, a post he continued to hold for four years. Under his authority, harsh measures enacted against the rebels brought an end to the threat of renewed rebellion, although at dreadful cost in lives and Imperial good will.

Charges were brought against Urshukaan after his post was taken over by an Imperial appointee (Baronetess Rosa Demetriou). These accusations of excessive force, violation of various sophont rights codes, and embezzlement of tax revenues were dismissed, but Urshukaan resigned in protest over the government's treatment of him. Still regarded in many areas as a hero for his firm stance on

Scaramouche, Urshukaan was offered the presidency of Lamarck Minerals, LIC. Under his direction, the company stabilised a declining profit picture and became a significant factor in the resource exploitation field in the Arcturus, Banasdan and Sol subsectors.

Over the years, Urshukaan has earned a reputation for sharp dealing. He is widely regarded for his skill in business practices but also considered to be a freewheeling, unprincipled, unscrupulous man who uses any means, fair or foul, to win his way. This particular aspect of his character has earned him many enemies.

Urshukaan has no children. He and his wife Sharik have been on bad terms for the last two years. They have lived apart through most of that period.



## MARTIN LUKARGIK

### Urshukaan's Personal Assistant

SPECIES		GENDER		AGE
Human		Male		38
TRAITS				
—				
STR	8	INT	9	SKILLS
DEX	8	EDU	8	Admin 1,
END	6	SOC	7	Electronics (computers) 2,
PSI	—			Gun Combat (slug) 1,
				Jack-of-All-Trades 2
WEAPONS		Body Pistol (2D)		
EQUIPMENT		Mobile Comm		

#### KNOWN BACKGROUND:

Lukargik has been employed by Lamarck for the past 10 years; the last five years have seen him as Urshukaan's number one assistant. His record has been exemplary. He is ambitious, hardworking and dedicated to the company.



Notes in his personnel file show him to be ambitious, hard-working, dedicated to the company and he has been recommended several times for a managerial post.

## EAYUKHEAL

### Urshukaan's Security Consultant

SPECIES		GENDER		AGE
Aslan		Male		42
TRAITS				
—				
STR	10	INT	6	SKILLS
DEX	6	EDU	6	Admin 1,
END	11	SOC	0	Electronics (computers) 1,
PSI	—			Gun Combat (slug) 1,
				Leadership 2,
				Melee (natural) 2,
				Recon 1,
				Tactics (military) 2
WEAPONS		Dewclaw (1D+2)		
EQUIPMENT		Mobile Comm		

#### KNOWN BACKGROUND:

An ex-Imperial Army major, Eayukheal served as Urshukaan's second in command during the rebellion on Scaramouche. Decorated twice for gallantry, he retired shortly after Urshukaan resigned his commission and has been employed as a 'security consultant' by Lamarck ever since. The job



description is a vague one; it appears Eayukheal travels a great deal, inspecting and advising on the security aspects of various company facilities.



## KATARIN XUAN

### Urshukaan's Mistress

SPECIES		GENDER		AGE
Human		Female		26
TRAITS				
STR	6	INT	5	SKILLS
DEX	9	EDU	8	Gambler 1, Melee (blade) 1
END	5	SOC	7	
PSI	—			
WEAPONS		Heraklionian Dagger* (1D+2)		
EQUIPMENT		Mobile Comm, Cr500		

#### KNOWN BACKGROUND:

Xuan is widely known to be Urshukaan's latest mistress. She is the daughter of an impoverished Lamarck miner from Heraklion who caught Urshukaan's eye during his last inspection tour there. A greedy, rather brainless little gold-digger, Xuan saw Urshukaan as her ticket out of poverty and has used him as a means to indulging her passion for luxuries



and money. When first encountered, she sports a black eye and other bruises, and makes no secret of the fact Urshukaan has been mistreating her.

\*Her dagger might not be on her person.

## ENLI ALNASR

### Urshukaan's Bodyguard

SPECIES		GENDER		AGE
Human		Male		34
TRAITS				
STR	11	INT	3	SKILLS
DEX	6	EDU	5	Gambler 1, Gun Combat (slug) 1, Melee (blade) 1, Melee (unarmed) 3, Recon 3
END	12	SOC	3	
PSI	—			
WEAPONS		Assault Pistol (3D-3, Auto 2)		
ARMOUR		Mesh (+2)		
EQUIPMENT		Mobile Comm, Cr500		

#### KNOWN BACKGROUND:

After serving as a marine, Enli has worked as Urshukaan's bodyguard for the last three years. He is a man of few words and takes pleasure in removing upset people from his boss's office. When not working, he is often found in the casino.

He was unfortunately not present to guard his master on the night of Urshukaan's murder, having injured himself in a fall down a flight of stairs just a few



hours before. Enli spent the evening in the dispensary, earning him a rock-solid alibi. With Urshukaan dead, he obeys Lukargik; he is also secretly infatuated with Katarin and may attempt to help her if he suspects she is in danger.



## HART FONROE

### Captain of the Mining Craft GT-56

SPECIES		GENDER		AGE
Human		Male		42
TRAITS				
STR	6	INT	8	SKILLS
DEX	9	EDU	6	Electronics (computers) 2,
END	8	SOC	7	Electronics (remote ops) 2,
PSI	—			Melee (blade) 2, Persuade 2,
				Pilot (small craft) 3, Stealth 1,
				Vacc Suit 2
WEAPONS		Blade (2D), Body Pistol (2D)		
ARMOUR		Mesh (+2)		

#### DESCRIPTION

Lean with greying brown hair. His employee photo shows a neat beard but he has since shaved it.

#### BACKGROUND:

Born and raised as a belter, Hart has worked in mining his entire life. When Lamarck Minerals hired him as a mining boat captain, he thought he had found a good thing but after Ringiil Urshukaan was appointed president of the company, everything



changed. Hart threw himself into helping establish a union to help fight the injustices but after the L4-M7 was lost, taking four of his friends with it, his focus changed to revenge.

He knows his only choice is to escape the system in the Sabre IV. He does not surrender or allow himself to be captured under any circumstance.

## KARI GIMSA

### Sensor Operator of the GT-56

SPECIES		GENDER		AGE
Human		Female		32
TRAITS				
STR	6	INT	9	SKILLS
DEX	11	EDU	6	Athletics (dexterity) 2,
END	7	SOC	6	Electronics (sensors) 3,
PSI	—			Gun Combat (energy) 1,
				Melee 0, Stealth 1, Vacc Suit 2
WEAPONS		Laser Pistol (3D+3), Heraklionian Dagger (1D+2)		
ARMOUR		Jack (+1)		

#### DESCRIPTION

Tall with dark skin. Cropped curly hair and golden-brown eyes.

#### BACKGROUND:

After the loss of her parents when she was 15, Kari Gimsa had to raise both herself and her little brother Lance. She looks on Captain Fonroe as a father-figure



and was easily converted to the captain's plot. Kari still considers herself as her brother's protector. She will never endanger him. As with other women of Heraklion, she carries a slender dagger.



## BORIS DAVLIN

### Engineer of the GT-56

SPECIES		GENDER		AGE	
Vargr		Male		40	
TRAITS					
—					
STR	8	INT	8	SKILLS	
DEX	10	EDU	9	Athletics (dexterity) 1, Engineer (power) 1, Engineer (m-drive) 2, Mechanic 3, Gun Combat 0, Melee (natural) 3, Stealth 1, Vacc Suit 3	
END	4	SOC	8		
PSI	—				
WEAPONS		Autopistol (3D-3), Bite (1D+1)			
ARMOUR		Mesh (+2)			
EQUIPMENT		M Probe			



#### DESCRIPTION

Grey furred Vargr, blue eyes, notched left ear.

#### BACKGROUND:

Unlike the rest of the conspirators, Boris Davlin did not join the conspiracy out of a need for revenge or loyalty to Captain Fonroe. He is in it for the money. Boris figured out his being Vargr has limited his

advancement opportunities in human-owned companies such as Lamarck Minerals. His share of profits from the heist can set him up for life and he intends to kill anyone who gets in his way.

## ALLIE TIMMON

### Turret Operator of the GT-56

SPECIES		GENDER		AGE	
Human		Female		30	
TRAITS					
—					
STR	10	INT	5	SKILLS	
DEX	12	EDU	6	Athletics 0, Electronics (computers) 2, Gunner (turret) 2, Gun Combat (slug) 1, Pilot (small craft) 1, Vacc Suit 1	
END	8	SOC	5		
PSI	—				
WEAPONS		Submachine Gun (3D, Auto 3)			
ARMOUR		Mesh (+2)			



#### DESCRIPTION

Tall with short, purple hair and numerous tattoos.

#### BACKGROUND:

Allie grew up self-conscious of her physical size. Many find her intimidating but not Captain Fonroe. He treated her as an equal and a valued member of his crew. She is fiercely loyal to Fonroe and was the first to join his plot to steal the ore carrier.



## DYRROL MOLLIK

### Dock Crew at Station Three

SPECIES		GENDER		AGE
Vargr		Male		38
TRAITS				
STR	6	INT	8	SKILLS
DEX	10	EDU	9	Carouse 1, Deception 0, Electronics (computers) 2, Engineer (power) 2, Engineer (m-drive) 2, Gun Combat 0, Mechanic 3, Melee (blade) 2, Persuade 2, Stealth 3, Vacc Suit 1
END	4	SOC	8	
PSI	—			
WEAPONS				
EQUIPMENT				Computer (TL12), Mobile Comm, Tool Laser (TL13)

#### DESCRIPTION

Dark grey furred Vargr, yellow eyes, scar along face from accident years ago.



#### BACKGROUND:

Dyrrol appears extremely friendly and outgoing. He is known by the rest of the dock crew for his jokes as much as his skills. Hidden beneath his friendly exterior is a desperate need to belong. He takes great pride in being involved in the plot and wants to prove his worth to Captain Fonroe. His enthusiasm makes him dangerous, as he may take unnecessary risks or go to extreme measures in thwarting the Travellers.

## LANCE GIMSA, Turret Operator of the Mining Craft BT-23

SPECIES		GENDER		AGE
Human		Male		30
TRAITS				
STR	5	INT	7	SKILLS
DEX	10	EDU	9	Astrogation 0, Electronics (computers) 2, Electronics (remote ops) 2, Melee (blade) 2, Persuade 2, Pilot (small craft) 3, Stealth 1, Vacc Suit 2
END	11	SOC	6	
PSI	—			
WEAPONS				
ARMOUR				Jack (+1)
EQUIPMENT				Computer (TL10), Mobile Comm

#### DESCRIPTION

Dark skin, shaven head, golden-brown eyes. Multiple ear piercings.

#### BACKGROUND:

Raised by his sister Kari since he was 13, Lance hopes to impress her. She easily convinced him to join in the plot and he threw himself into his study



to become a qualified astrogator. He is known as soft-spoken and is slow to anger unless his sister is involved. He would gladly face prison for their crimes if it meant protecting her.



## MOSHE SRINIVASAN

### Miner, Katarin's Ex-Fiancée

SPECIES		GENDER		AGE
Human		Male		30
TRAITS				
STR	11	INT	4	SKILLS
DEX	12	EDU	6	Melee (unarmed) 2, Pilot (small craft) 1, Profession (belter) 2, Vacc Suit 2
END	10	SOC	4	
PSI	—			
EQUIPMENT		Two Middle Passage tickets, Cr1000		

#### KNOWN BACKGROUND:

Moshe Srinivasan is a miner from Heraklion employed by one of Lamarck Minerals' subsidiaries. Poor, but without any particularly bad record, Srinivasan resigned from Lamarck shortly after Urshukaan's recent inspection tour at Heraklion. Little else is known concerning the miner, who is large, aggressive and not very bright.



## SHARIK URSHUKAAN

### (KASHIN THANH), Urshukaan's Wife

SPECIES		GENDER		AGE
Human		Female		50
TRAITS				
STR	4	INT	10	SKILLS
DEX	7	EDU	9	Admin 1, Electronics (computers) 2, Gun Combat (slug) 2, Jack-of-All-Trades 2, Medic 1, Pilot (spacecraft) 3
END	5	SOC	8	
PSI	—			
WEAPONS		Silenced Body Pistol* (2D)		
EQUIPMENT		Mobile Comm, Sterr Allure Perfume		

#### KNOWN BACKGROUND:

Sharik is travelling under the name Kashin Thanh. As Thanh, she has no ostensible connection with the crime and, indeed, no record in the Wainwright Starport computers (she entered the system under her real name, so if she comes under suspicion as Thanh, the lack of starport records should generate further suspicion). She has, however, been seen near Urshukaan's suite once or twice (including once on the night of the murder) and some station employees volunteer the information that she was asking questions about Urshukaan's quarters, his movements in the station and his planned itinerary.



Sharik has a fondness for Sterr Allure, an expensive perfume with a distinct citrus tang. While pleasant, it may seem strange for a merchant pilot to be wearing a Cr500 a bottle scent. Bottles can be purchased at one of the higher-end station stores.

\*Her pistol might not be on her person.



## OOJAN M'BANKE, Head of the Independent Belters' Association

SPECIES	GENDER		AGE
Human	Male		38
TRAITS			
STR	11	INT	7
DEX	10	EDU	8
END	10	SOC	7
PSI	—		
EQUIPMENT			
Portable Computer (TL12)			

### KNOWN BACKGROUND:

A massive but usually gentle ex-asteroid miner, M'Banke is now head of the Independent Belters Association, which is lobbying for changes in Banasdan's treatment of small, independent mining concerns in the Arcturus Belt. A handful of larger corporations, focused around Lamarck Minerals, have been able to consistently block the IBA's attempts in persuading the government to lower licensing fees and otherwise ease the factors that make it nearly impossible for the independents to compete with corporate concerns.



Recently, M'Banke won the ear of an influential government official and it seems almost certain Banasdan policy in this area will be reversed. M'Banke was celebrating his triumph at Wainwright Station when he received an important personal message asking him to come to Station Three; he was heard to complain of this mysterious message to several people when he arrived, having no idea of why he was invited or who asked him to come.

## BORTAI NARAYANAM Chief Union Organiser

SPECIES	GENDER		AGE
Human	Female		38
TRAITS			
STR	8	INT	9
DEX	8	EDU	8
END	7	SOC	4
PSI	—		
WEAPONS			
Heraklionian Dagger (1D+2)			
EQUIPMENT			
Mobile Comm, Portable Computer (TL12)			

### KNOWN BACKGROUND:

Bortai Narayanam, formerly a miner, has become the spokesman and chief organiser of a labour movement, which is seeking to unionise Lamarck's employees and promote better working conditions. Bortai has spoken out against sabotages by Lamarck employees, urging them to fight the company through legal means. She and her union have been



a thorn in Urshukaan's side for months now. Urshukaan has reputedly tried everything to break up the union movement, including threats against Narayanam herself, so far to no avail.



## BARONETESS ROSA DEMETRIOU

### Former Governor of Scaramouche

SPECIES		GENDER		AGE
Human		Female		42
TRAITS				
STR	5	INT	11	SKILLS
DEX	10	EDU	10	Admin 3, Carouse 1, Electronics (computers) 2, Gun Combat (slug) 2, Leadership 2, Pilot (small craft) 1
END	6	SOC	12	
PSI	—			
WEAPONS		Body Pistol (2D)		
EQUIPMENT		Yacht, Mobile Comm, Wafer Jack		



#### KNOWN BACKGROUND:

Baroness Rosa Demetriou, youngest daughter of the 18<sup>th</sup> Baron Demetriou of Champa, rose to a prominent level of the sector administrative hierarchy before her career ended in a cloud some eight years ago. Her last official post was as Governor of Scaramouche, which she took over from Acting Governor General Urshukaan. It was on her recommendation that Urshukaan was charged with using unnecessary force and exceeding his authority in his treatment of the rebels on the planet; most

of Demetriou's administration was spent in attempts to rebuild shattered relations and restore Imperial good will. These efforts were not wholly successful and were cut short when discrepancies in the treasury were traced to the Baroness. Charges of malfeasance were brought against her. She resigned under a cloud and, although pardoned by a high official in the sector government, never again held any post connected with the government.

## AKBAR

### The Baroness's Loyal Servant

SPECIES		GENDER		AGE
Human		Male		46
TRAITS				
STR	9	INT	9	SKILLS
DEX	9	EDU	7	Electronics (computers) 2, Gun Combat (slug) 1, Jack-of-All-Trades 1, Mechanic 2, Melee (blade) 3, Melee (unarmed) 3, Stealth 2
END	4	SOC	2	
PSI	—			
WEAPONS		Scaramouche Dagger (1D+2), Autopistol (3D-3)		
EQUIPMENT		Mobile Comm		



#### KNOWN BACKGROUND:

Bearing a distinctive scar across his throat, Akbar is unable to speak – the result of a wound suffered when a laser burn ruined his larynx. Akbar was a rebel on Scaramouche prior to his capture; the Baroness pardoned him in exchange for his help in rooting out a stubborn nest of rebel resistance. Her

kindness (she provided medical aid at her own expense) led him to become her devoted servant. He acts as a combined factotum and highly talented bodyguard.



## CHAIJIN DAVIS

### Solomani Agitator

SPECIES		GENDER		AGE
Human		Male		30
TRAITS				
STR	8	INT	10	SKILLS
DEX	8	EDU	9	Carouse 0, Explosives 1, Gambling 1, Gun Combat (slug) 1, Jack-of-All-Trades 1, Melee (blade) 1, Stealth 2, Streetwise 2
END	5	SOC	3	
PSI	—			
WEAPONS		Scaramouche Dagger (1D+2), Body pistol (2D)		

#### KNOWN BACKGROUND:

A native of Scaramouche, Chaijin Davis has an obscure background. A check of his entry records at the starport reveals an attached note from Imperial authorities; Davis is a known Solomani agitator and should be watched; he was arrested two years ago on Hathor for political agitation and inciting a riot (charges dropped); three years ago on Murphy on suspicion of involvement in a plot to hijack a starship (not proven); six years ago on Umber for rioting and



destruction of public property and nine years ago on Cambyses as the main organiser of a series of college political protests (sentence suspended). Little more is available on him.

## TARIL ULGEEV

### Vengeful Psion Agent

SPECIES		GENDER		AGE
Human		Female		34
TRAITS				
STR	6	INT	8	SKILLS
DEX	8	EDU	9	Carouse 0, Deception 2, Gun Combat (slug) 1, Melee (blade) 2, Streetwise 2, Telepathy 3, Telekinesis 0
END	6	SOC	5	
PSI	11			
WEAPONS		Dagger (1D+2), Snub pistol (3D-3)		
EQUIPMENT		Medical Injector with Standard Psi-Drug, Portable computer (TL13)		
SPECIAL ABILITIES		Taril's psionic training has opened a rare, almost unique ability to erase a subject's short-term memory known as Mind Wipe.		

#### KNOWN BACKGROUND:

With a professional appearance and respectable attire, Taril appears every bit the businesswoman she claims to be. Her entry records at Wainwright Starport state she is visiting for family business. Her employment



record shows her to be an independent negotiator hired to assist in brokering deals between various companies. Taril claims that contractual non-disclosure clauses prevent her from speaking of which companies she has worked with.



# LIBRARY DATA

The following library data entries are available in response to the correct keywords on any public terminal at Station Three.

## HERAKLION

Planet in the Arcturus subsector of the Solomani Rim (D343312-E).

A poor, non-industrial planet, the world is given over to resource exploitation. Heraklion is currently owned and operated by Lamarck Minerals, LIC.

The planet is largely unremarkable, although the culture that has developed is of some interest to sociologists. A rough, poorly policed society, the planet has fostered the development of a strong streak of self-reliance. Most of the inhabitants are accustomed to bearing arms from an early age; this is less noticeable in the men (who instead tend to be trained in various types of unsophisticated hand-to-hand combat) than in the women. Most women on Heraklion carry daggers of a distinctive and highly useful design. A woman of Heraklion caught without her dagger in public (or deprived of it against her will) is subjected to considerable shame and humiliation.

## L4-M7

An Agrilus mining craft owned and operated by Lamarck Minerals, LIC. The vessel was lost in a mining accident 14 months ago. While official reports concluded the accident was due to pilot error, crashing the L4-M7 directly into an asteroid, persistent rumours claim the tragedy was the result of poor maintenance. Lamarck Minerals had recently loosened the safety guidelines on its fleet just before the L4-M7 was due for its most recent inspection and service.

The crewmembers lost were Ahsha Trent, Steven Marrit, Perdal Ulgeev and Sadie Kim. Their names, and that of the L4-M7, have become symbols to the disgruntled mining community.

## LING-STANDARD PRODUCTS

Originally a mining firm (and still very active in that field), LSP currently is engaged in a wide spectrum of activities including the manufacture of electronic

equipment of all sorts, ground and air vehicles, starships and starship armaments, drive systems, power systems, computers and software, small arms, and a variety of consumer goods. Concerned to a small degree with banking, insurance and stockbrokerage, LSP maintains mining and manufacturing facilities throughout the Imperium.

## SCARAMOUCHE

Planet in the Harlequin subsector of the Solomani Rim (A7C6503-9). One of the few worlds in the Solomani Rim where local longing for the 'good old days' of Solomani rule remains strong enough to give rise to active unrest, Scaramouche is a comparatively backwater world of little importance.

The planet's harsh atmospheric conditions and relative lack of value contributed significantly to the continuation of Solomani sympathies. Resistance to the presence of an Imperial governor and a brigade of marines at the starport capital led, in 1098, to the outbreak of the so-called Unity Uprisings against the government. The uprising was largely suppressed by Acting Governor General Ringiil Urshukaan, although his methods were harsh and later repudiated by higher authority (despite Urshukaan's popularity on nearby worlds, which perceived his actions as decisive in preventing a recurrence of unrest in that portion of the sector).

The organisation of the rebellion effectively collapsed after Urshukaan's capture of its major leader, Moradeyo Davis Atiyah.

After the short administration of Governor Baronetess Rosa Demetriou, in which attempts at reconciliation were begun, it was decided that the Imperial presence on Scaramouche would be greatly reduced. Government was formally turned over to the citizens of the planet seven years ago and the post of Governor dissolved. The majority of the garrison was withdrawn at that time.

Since the Imperial withdrawal, government on Scaramouche has varied from unstable to non-existent. Numerous splinter groups of the local Solomani party have caused the movement to collapse from internal bickering, while no other political force has emerged. Violence is common and the world has been designated an Amber Zone by the Travellers' Aid Society.





# ARCTURUS STATION

These adventures are not, primarily, gadget driven. Some items, however, are described here.

**A03/48956**

## FLASHTRAY

The flashtray is a small, desk-top convenience used to incinerate small items, particularly cigarettes, sensitive documents and the like. Any flammable item placed in the flashtray is reduced to a pile of ashes in a matter of seconds. Built-in fans draw in any smoke or smell from the flashtray's use. Some flashtrays can be extremely ornate with artistic designs and accents in precious metals.

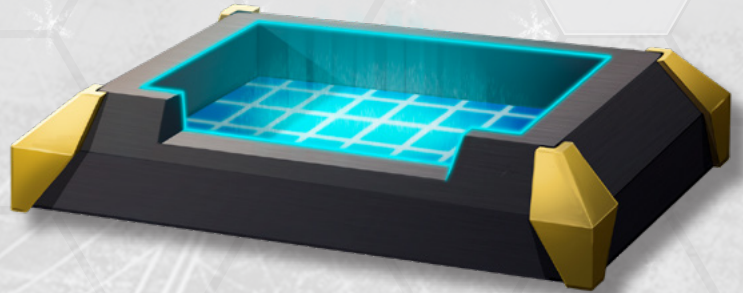

Item	TL	Kg	Cost
Flashtray	8	0.5	Cr80

**A03/75674**

## HERAKLIONIAN DAGGER

This slender blade is carried by the women of Heraklion. Great pride is taken in the weapon. Their handles are often fashioned out of expensive materials and the blades engraved with artistic motifs. Having no cross guard allows them to be easily hidden. Heraklionian women always carry these daggers and the loss or theft of one is a source of great shame.

Any attack that rolls a natural 6 for damage also inflicts one point of damage to DEX on a permanent basis. This represents lost sections of tendon, severed fingers and other injuries that will not heal without restorative surgery or some form of replacement.



Weapon	TL	Range	Damage	Kg	Cost	Magazine	Magazine Cost	Traits
Heraklionian Dagger	2	Melee	1D+2	1	Cr200	—	—	—



A03/48956

## PSI-DETECTOR

This device is one of the earliest portable instruments for testing psionic ability. Slightly larger than a standard suitcase, its description as portable is questionable. The subject is fitted with an expandable band across their head, which wirelessly connects to the device. Wireless range is 10 metres. It not only reads whether the subject possesses a PSI score but the level of psionic strength. Operating the machine requires a Difficult (10+) Electronics (sensors) check (1D minutes, INT or EDU) with the subject's PSI score as a positive DM. Subjects under the effect of an inhibitor drug inflict DM-2 to this check.

Banasdan civil code requires probable cause be established before the test can be performed on an unwilling subject. While guilt of being a psion in Imperial jurisdiction is still applicable, charges may be brought against violators who administer the test without legally justified reasons, regardless of the results.



Item	TL	Kg	Cost
Psi-Detector	13	10	Cr5000

A03/75674

## SCARAMOUCHE DAGGER

Constructed of hard, yet flexible polymers, this leaf-bladed dagger is open in the middle, giving it the appearance of an eye. It is only made only on Scaramouche and considered an unofficial symbol of the Solomani rebels. Due to materials of their construction, Scaramouche daggers impose DM-4 to any Electronics (sensors) checks attempting to detect them.



Weapon	TL	Range	Damage	Kg	Cost	Magazine	Magazine Cost	Traits
Scaramouche Dagger	8	Melee	1D+2	1	Cr200	—	—	—



A03/48956

## SLAG CHARGE

These devices generate great amounts of heat; used on occasion for military applications, such bombs are far more frequently employed by civil engineering or mining personnel engaged in asteroid construction work. The intense heat is used to slag down areas of an asteroid's surface, so braces, pylons and other structural elements can be set into molten rock which, when it cools, provides an extremely secure foundation. The timer employed is also part of the standard package and allows a charge to be set with up to a one-hour delay.



Weapon	TL	Range	Damage	Kg	Cost	Traits
Slag Charge	7	—	6D	1	Cr250	Blast 1

A03/75674

## STRESS DETECTOR

The linear descendant of the polygraph, the stress detector uses readings of a suspect's physical responses, voice stress and similar phenomena to establish their degree of truthfulness under questioning. It is not, however, necessarily accurate in its readings and interpretation is a complex matter.

In order to properly interpret a detector's readings, either a highly competent operator (none is present on the station) or a properly programmed computer/2 or better (the station has one of these) must be consulted. If an operator or computer is available, the accuracy of a stress detector's readings is determined by the machine's Tech Level. Subjects must roll 2D for each question. The device's Tech Level determines the target number required to deceive the machine. Various modifiers are applied to this basic throw.

For every 15 minutes (maximum one hour) spent in preliminary 'registration questions' (to set up the parameters of the subject's normal stress reading) inflicts DM-1. The Electronics (sensor) skill of the operator is also used as a negative DM.

On the other hand, stress detectors are not infallible. Clever subjects can wreak havoc with the stress detector's results. A subject who throws an Average (8+) INT check before undergoing a stress detector interrogation may add DM+2 to the roll made against each question. Deception or Streetwise skill level is also used as a positive DM.





A03/75674

## STRESS DETECTOR (CONTINUED)

The referee should always keep the interrogation rolls a secret. The questioner knows only what the machine tells concerning truth or falsehood. A subject is never sure when the questioners have been fooled, except by their attitudes. Note that inaccuracy can cause a truthful statement to be interpreted as a lie (the subject is nervous); also, a subject must specify the intent to confuse the machine in order to bring positive DMs into play.

Banasdan law (under which the station operates) expressly prohibits the use of stress detectors without the full consent of the subject being examined. If the subject does not agree (and many of the suspects would not), use of the machine is a violation of the suspect's civil rights. Evidence gathered in this fashion would be inadmissible (a mistrial would no doubt result

in the case of the guilty party); the Travellers, as official investigators appointed by the highest government authority present (the station manager), would be fined (Cr2Dx100 apiece); a suspect whose rights were so violated could sue the Travellers for amounts ranging into millions of Credits for the violation. In short, the referee should make it clear that nothing will work out if the group flagrantly ignores the rights of those concerned – thus ensuring that brains, and not gadgetry, are used to solve the mystery. Although the Travellers are granted access to the station computer, they are certainly not allowed to use it in conjunction with illegal operation of the stress detector.

Item	TL	Kg	Cost
Stress Detector	14	6	Cr1500

A03/48956

## TRUTH SERUM

Truth serum is designed to force the Traveller to answer questions truthfully. It must be tailored to the species being questioned and carries some risks. One dose usually forces the Traveller to pass a Difficult (10+) END check or be unable to lie for 1D minutes. At the end this period, the subject suffers 2D damage and becomes unconscious for an hour. Truth serum tends to make the Traveller vague and confused, so their answers may be nonsensical despite them not deliberately lying. Obtaining useful information from a Traveller usually requires the Persuade skill, with the truth serum granting DM+2 against a difficulty determined by the nature of the information sought.

It should be noted that the same regulations adhering to stress detector tests apply to truth serum as well, in regard to legal considerations.

Item	TL	Kg	Cost
Truth Serum	5	—	Cr500





# HIGH GUARD: ARCTURUS STATION

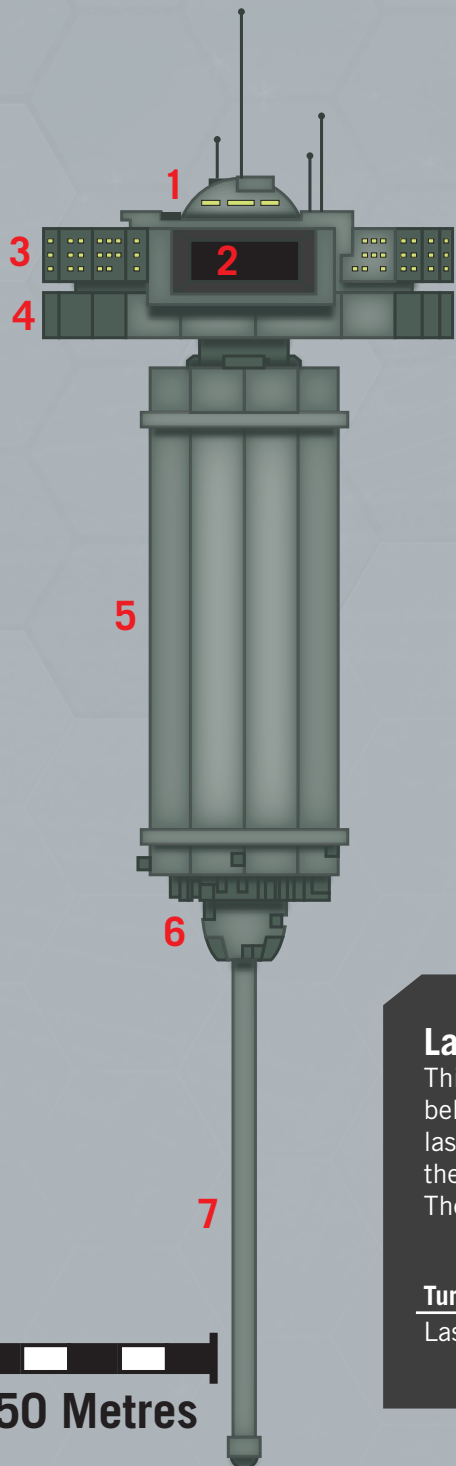

**ARCTURUS STATION THREE**

1. Bridge
2. Docking Bay
3. A module
4. B Module
5. Stores and Fuel
6. Power Plant
7. Manoeuvring and Altitude Control

**A MODULE (3 DECKS)**

**Upper deck:** Offices, work areas, employees’s quarters

**Middle deck:** Guest staterooms

**Lower deck:** Lounge, restaurant, dispensary, casino, passengers loading area

**B MODULE**

Station facilities, cargo loading, shuttle servicing

**Laser Drill**

This turret-mounted laser is more of a tool than a weapon, used by beltors to penetrate asteroids and reach valuable ores. Salvagers also use laser drills to gain entry into derelict ships. However, in an emergency, the laser drill makes for a potent, if very short-ranged, ship’s weapon. The laser drill suffers DM-3 to attack rolls if used as a weapon.

Turret Weapon	TL	Range	Power	Damage	Cost	Traits
Laser Drill	8	Adjacent	4	4D	Cr150000	—



## ARCTURUS STATION THREE

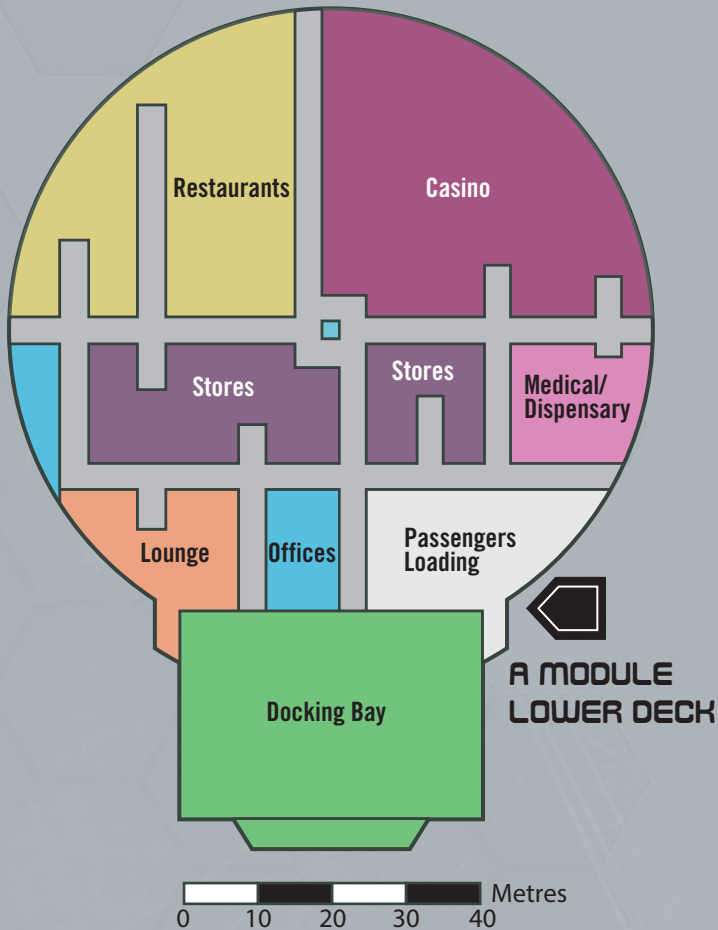

### A MODULE MIDDLE DECK



- |                      |                           |
|----------------------|---------------------------|
| 1. Travellers' Room  | 7. The Baronetness' Suite |
| 2. Srinivasan's Room | 8. Ulgeev's Room          |
| 3. Davis' Room       | 9. Urshukaan' Suite       |
| 4. Narayanam's Room  | 10. Lift Shaft            |
| 5. M'Banke's Room    |                           |
| 6. Sharik's Room     |                           |

### (Murder at Arcturus Station) Guest Staterooms

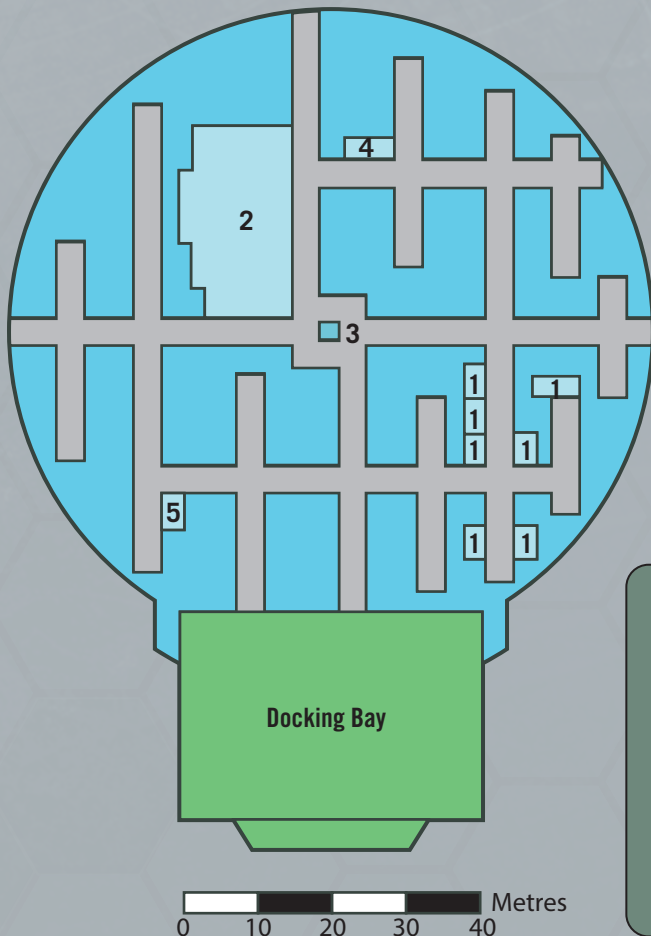
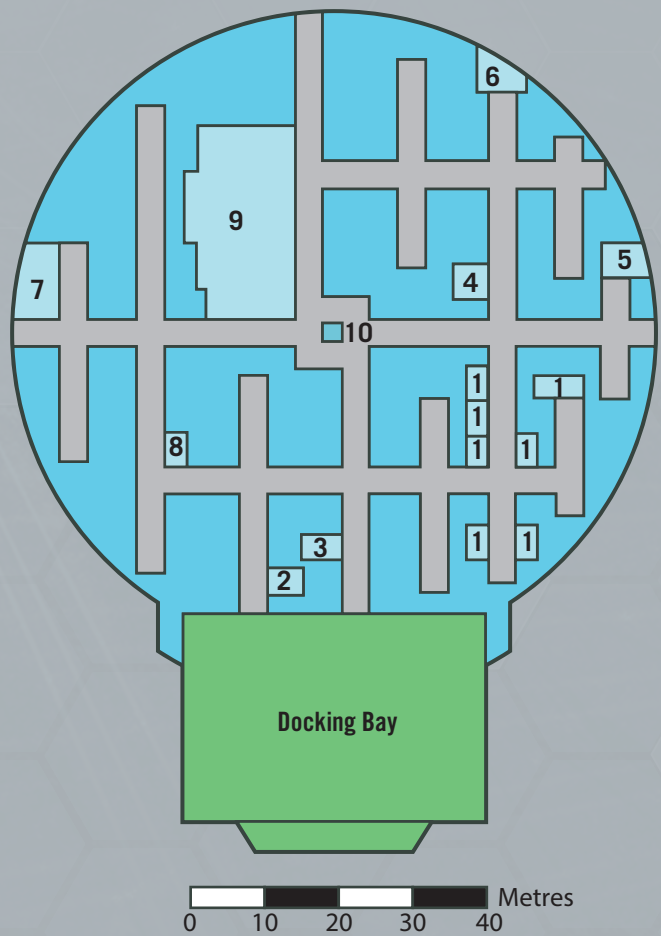

### A MODULE MIDDLE DECK

1. Travellers' Room
2. Urshukaan' Suite
3. Lift Shaft
4. Hummit Madson's Room
5. Dyrrol Mollik's Room

### (Hunt for Sabre IV) Guest Staterooms



# AM-20 MINING CRAFT

AGRILUS

TL12		TONS	COST (MCR)
<b>Hull</b>	60 tons, Standard	—	3
<b>M-Drive</b>	Thrust 2	1.2	2.4
<b>Power Plant</b>	Fusion (TL12), Power 45	3	3
<b>Fuel Tanks</b>	4 weeks of operation	1	—
<b>Bridge</b>		6	0.5
<b>Computer</b>	Computer/5	—	0.03
<b>Sensors</b>	Improved	3	4.3
	Mineral Detection Suite	—	5
<b>Weapons</b>	Single Turret (laser drill)	1	0.35
<b>Systems</b>	Mining Drones x5	10	1
	Grappling Arm	2	1
<b>Staterooms</b>	Standard x2	8	1
<b>Software</b>	Manoeuvre/0	—	—
	Library	—	—
<b>Common Areas</b>		—	—
<b>Cargo</b>		24	—
<b>TOTAL: MCR</b>			<b>21.58</b>

## CREW

PILOT, SENSOR OPERATOR,  
ENGINEER, GUNNER

## RUNNING COSTS

**MAINTENANCE COST**  
Cr1798/month

•••••

**PURCHASE COST**  
MCR21.58

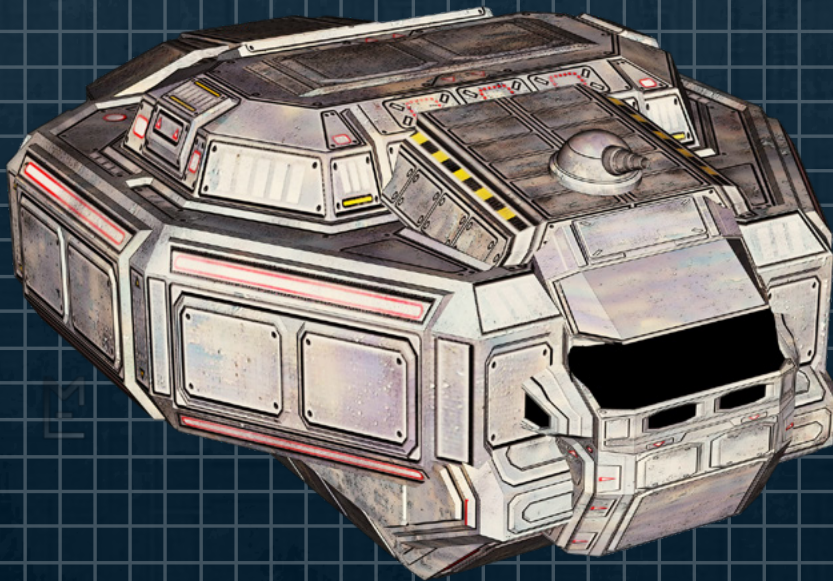



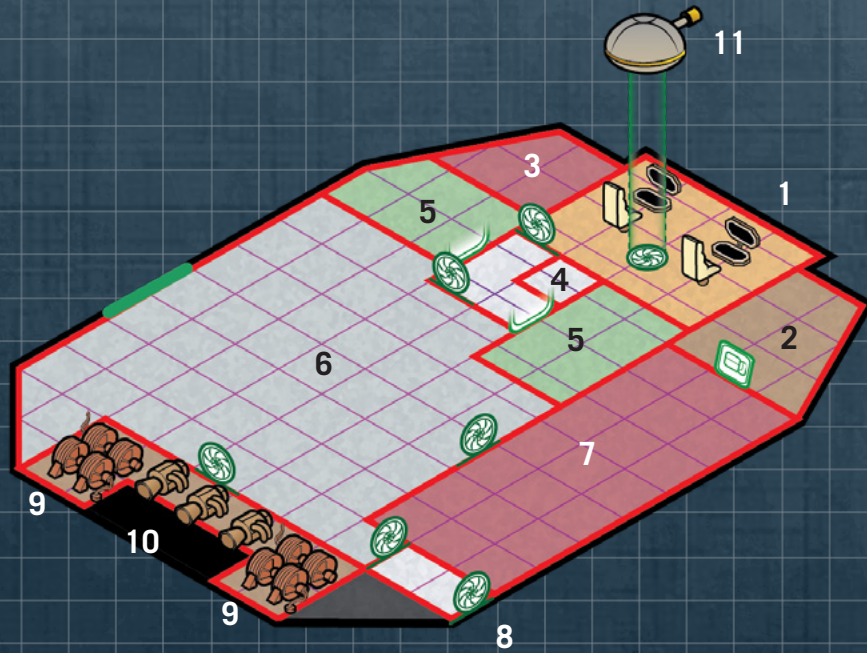

**LEGEND**

- 1. Bridge
- 2. Sensors
- 3. Grappling Arm
- 4. Fresher
- 5. Stateroom
- 6. Cargo Hold
- 7. Mining Drones
- 8. Air Lock
- 9. Power plant
- 10. Manoeuvre Drive
- 11. Mining Drill



**POWER REQUIREMENTS**

12	12	—
MANOEUVRE DRIVE	BASIC SHIP SYSTEMS	FUEL PROCESSOR
—	4	5
JUMP DRIVE	SENSORS	WEAPONS

24

HULL POINTS

The *Agrilus* is a small vessel used by corporate belt miners across the Imperium. Its excellent sensor suite, laser drill, drones and grappling arm make it a popular craft for intrasystem mining. It is relatively cramped, with crew accommodations being more of an afterthought. While not jump-capable, the *Agrilus* is frequently complimented by the far larger AM-650 ore carrier, which is.



# AM-650 ORE CARRIER

SABRE

TL12		TONS	COST (MCR)
Hull	1,500 tons, Standard	—	75
M-Drive	Thrust 1	15	30
J-Drive	Jump 2	80	120
Power Plant	Fusion (TL12), Power 765	51	51
Fuel Tanks	J-2, 8 weeks of operation	312	—
Bridge		40	7.5
Computer	Computer/5/bis	—	0.045
Sensors	Civilian Grade	1	3
Weapons	Double Turret (beam lasers)	1	1.5
Systems	Fuel Processor (100 tons/day)	5	0.25
	Fuel Scoops	—	1
	Loading Belt	1	0.003
	Docking Space (60 tons)	66	16.5
Staterooms	Standard x8	32	4
Software	Manoeuvr/0	—	—
	Jump Control/2	—	0.2
	Library	—	—
Common Areas		6	0.6
Cargo		890	-

**TOTAL: MCR 310.598**

## CREW

PILOT, ASTROGATOR,  
ENGINEER X 4, GUNNER,  
MECHANIC

## RUNNING COSTS

MAINTENANCE COST  
Cr25884/month

•••••  
PURCHASE COST  
MCR310.598

## POWER REQUIREMENTS

150

MANOEUVRE  
DRIVE

300

BASIC SHIP  
SYSTEMS

5

FUEL  
PROCESSOR

300

JUMP DRIVE

1

SENSORS

9

WEAPONS



600

HULL POINTS

The *Sabre* bulk ore carrier is a large and ponderously slow ship. Boasting an enormous hold, the *Sabre* is often found trailing several smaller and faster AM-20 mining craft. When a mining craft's payload is full, it docks with the *Sabre*, where loading belts transfer the ore into the larger vessel, while also refuelling the mining craft for further missions. Once its cargo hold has reached capacity, the *Saber* can jump to a different system to sell its payload. Much like its smaller counterpart, the *Sabre* offers very little in the way of crew comforts.

While eight or more is the recommended crew for a ship of such size, Lamarck Minerals, LIC, has reduced their *Sabre* crews to five. They are regularly assigned with four AM-20 mining craft at a time.



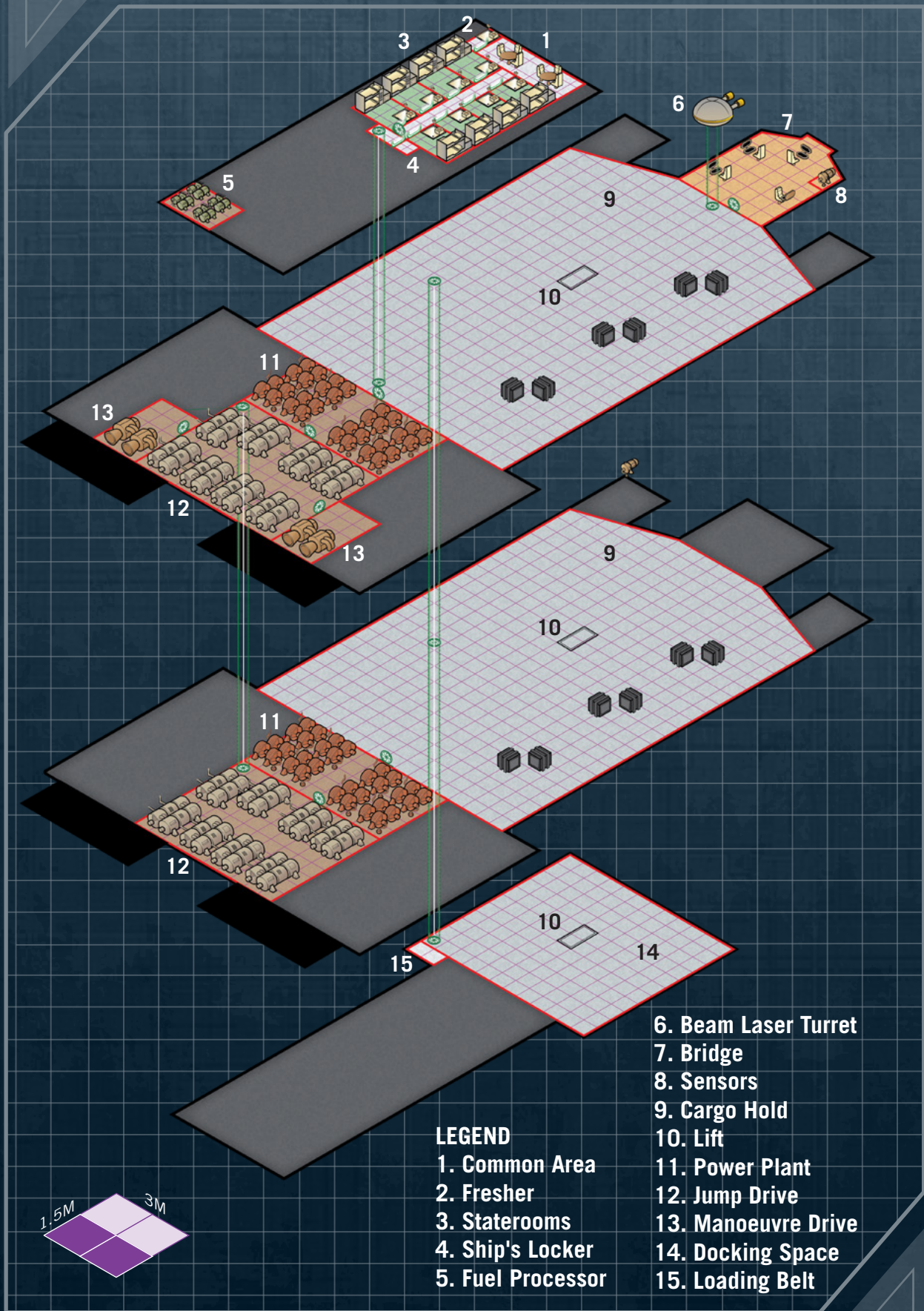

**LEGEND**

- 1. Common Area
- 2. Fresher
- 3. Staterooms
- 4. Ship's Locker
- 5. Fuel Processor
- 6. Beam Laser Turret
- 7. Bridge
- 8. Sensors
- 9. Cargo Hold
- 10. Lift
- 11. Power Plant
- 12. Jump Drive
- 13. Manoeuvre Drive
- 14. Docking Space
- 15. Loading Belt



# PLAYER HANDOUTS

Handout 1

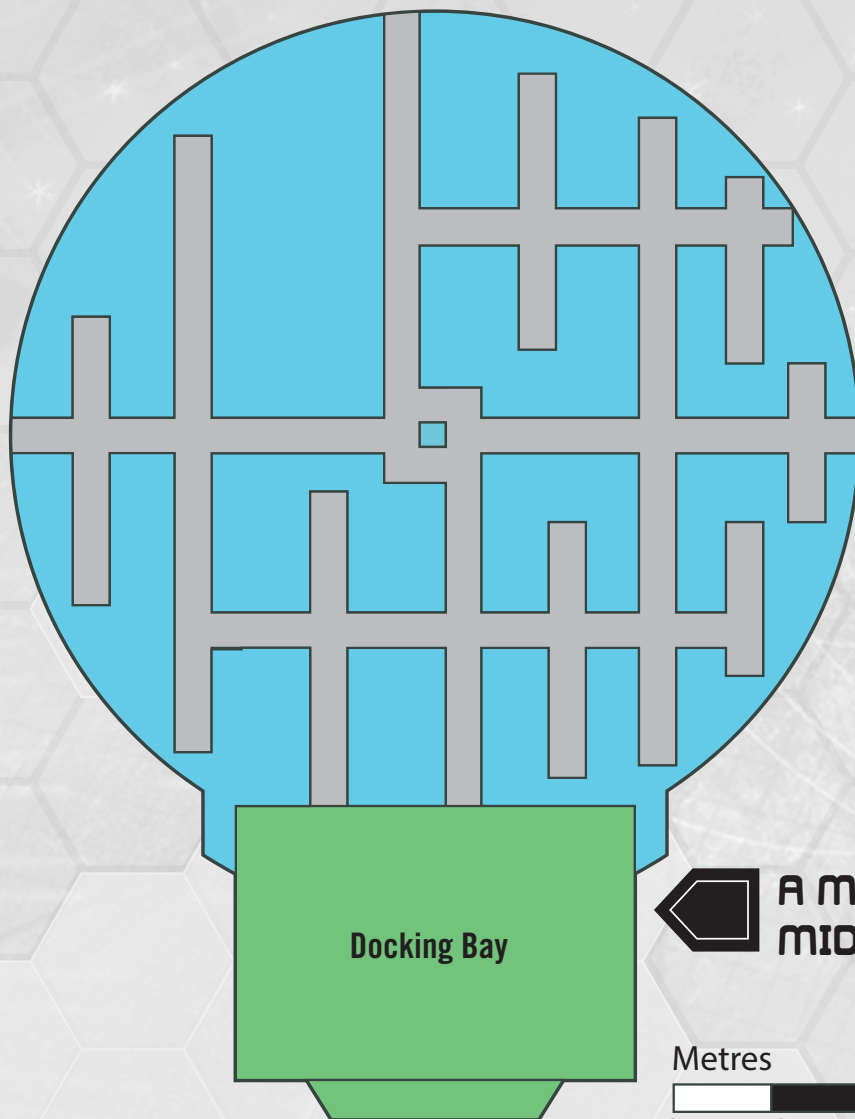

Handout 2

- Lamarck - Suleiman
- Heraklion - Noricum
- Anenerkuk - Gashurzid
- Arcturus - Harlequin
- Nyarlathotep - Hieronymous
- Tunguska - Ishmael
- Aqilat - Muan Gwi
- Anenerkuk - Heraklion
- Banasdan - Sathyos
- Lamarck - Melchior



# TRAVELLER

SOLOMANI ADVENTURE 1:  
MYSTERIES ON ARCTURUS STATION

Deep in the Arcturus Belt, Station Three serves as a hub for business, commerce, and much needed rest for hard-working asteroid miners. But beneath the veneer and flashing casino lights, it is a place of theft, treachery, and murder. *Mysteries on Arcturus Station* contains two separate investigative adventures which can be played individually or as a series, with one crime leading into the next.

In *The Hunt For Sabre IV* the Travellers are hired by a mining company to locate a missing ore carrier. What they uncover is conspiracy and murder. The Travellers must hurry to find the ship before the criminals can escape.

*Murder on Arcturus Station* is a reimagining of the Classic Traveller adventure. A corporate executive has been murdered, and Travellers are the prime suspects unless they can catch the killer in time. It is up to the referee to decide which of the ten suspects is guilty and how they did it. Was it the estranged wife? His mistress? The Solomani rebel? The Aslan noble? This adventure provides all the tools to construct each of the possible crimes, complete with motives, clues, alibis, and misleading information pointing to the wrong suspect.



MGP 40053

ISBN 978-1-913076-42-9



9 781913 076429

US \$24.99