

APRIL FOOL'S DAY SHIP PACK 2018

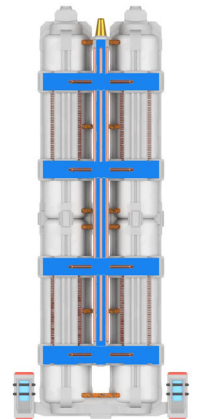
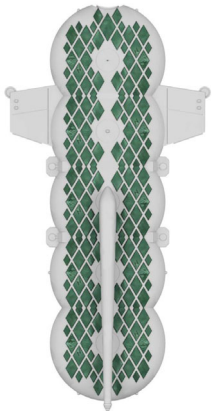
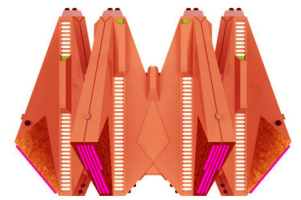
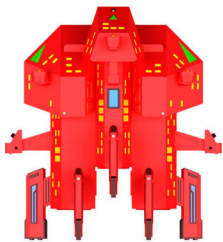

THIS PDF PACK INCLUDES:
Ship Descriptions & Histories
SSDs for *Star Fleet Battles*
Ship Cards for *Federation Commander*
Ship Cards for *A Call to Arms: Star Fleet*
Ship Cards for *Star Fleet Starmada*
Cards for *Star Fleet Battle Force*
Images for Counters
F&E Ship Information Table
SFB Master Ship Chart
**Mauler Rules for *ACTASF*, *SFBF*,
Federation Commander, and *Starmada***

This pack is not simply an efficient way to get the four April Fool's Day 2018 ships into the hands of players of all of our games, but is an excellent opportunity for players familiar with only one game to compare the six different games and explore other options for the *Star Fleet Universe*.

This pack is copyright © 2018 ADB Inc. All rights are reserved under the International, Pan-American, and Berne Copyright Conventions. Purchasers of this pack have permission to print a reasonable number of copies for personal use, but not for re-sale. Stock #9400.

DESCRIPTIONS OF NEW SHIPS

(R5.J9) KZINTI TRI-MARAN CRUISER (TRI): If the Lyrans thought that catamarans and trimarans were so darn cool, the Kzintis could not be faulted for experimenting with the concept. This late-war design, which would have been built from badly damaged war destroyer (R5.44) and frigate (R5.8) hulls scheduled for the scrapyards, was to be the Kzinti answer to the multiple-hulled Lyran battlecruisers (R11.3). Note that the design uses five war destroyer engines by retaining two engines on each of the war destroyer hulls and installing the fifth engine in place of the frigate hull's center warp engine.

The resulting ship (according to computer simulations) would have been extremely unmaneuverable for a ship of its size and subject to breaking down because the component elements were not originally designed to work in such a configuration.

Among the flaws was the concept of using already existing but heavily damaged ships to assemble the Tri-maran cruiser. Stripping the excess structural elements would have been expensive, but adding in the costs to refit and refurbish damaged hulls was excessive. It would be better, and much cheaper, to partially construct the three hulls to begin with, building the whole ship as a single unit. The problem then was that while the resulting ship was not as long as a dreadnought (R5.42), it was actually wider, and so could only be built (or assembled) in a dreadnought slipway, which would have curtailed production of dreadnoughts even though tri-marans could have been built faster.

The architect of this plan ("Cat-too-stupid-to-live" is the name the records show) was executed for treason only moments after proposing it.

This ship, while a design assembled from a combination of other ships, is considered to be a unique base hull. There are no variants. It could be built from scratch as a complete ship.

Seeking weapons: This ship can control a number of seeking weapons equal to double its sensor rating (F3.212). The drone racks on this ship were always four type-B (FD3.2) and two type-C (FD3.3) with two reloads. This ship could always launch drones at the maximum rate of the given drone rack each turn.

Refits: This ship included DERFACS and the Y175 refit in its design. There are no other applicable refits.

This ship originally appeared in *Star Fleet Times #13*. Further research refined what Cat-too-stupid-to-live actually submitted it prior to his execution. Using it in a game requires permission from the opponent's girlfriend (or other potentially bribable person designated by the opponent).

Status: Unbuilt design.

SSD is in *April Fool's Day Ship Pack 2018*, use any available Kzinti ship counter.

Known names: *Triple Threat*.

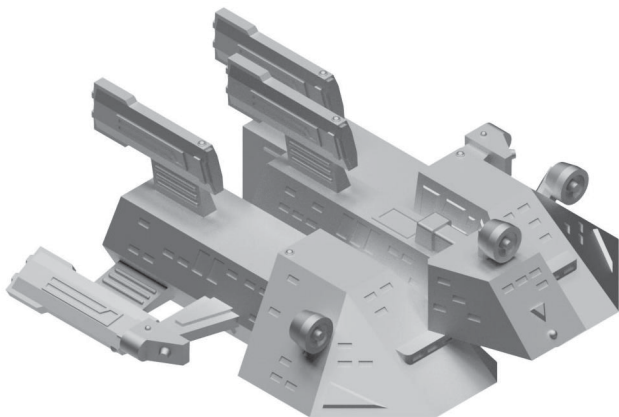

(R6.J12) GORN BUBBLE DREADNOUGHT (BDN): This is a proposed, but never built, design postulating that large ships could be constructed more easily through modular construction. The idea was to build component sections of a large ship and then assemble them, thereby saving shipyard space (since the modular components could be constructed in slipways designed for frigates (R6.33), construction of which would be discontinued). The resulting design (which may have been a demonstrator given the oddities in its layout) lacked a number of systems by Gorn standards. Ultimately, many of those limitations could not be accepted in a combat ship, and the interior design layouts of the various sections had to be changed to accommodate tactical and operational realities (although the number of shuttles were still reduced by 50%). The resulting design still had a notable increase in "available firepower" in that there were more phasers, but it did not have the power needed to fully utilize that firepower and operate at fleet speeds.

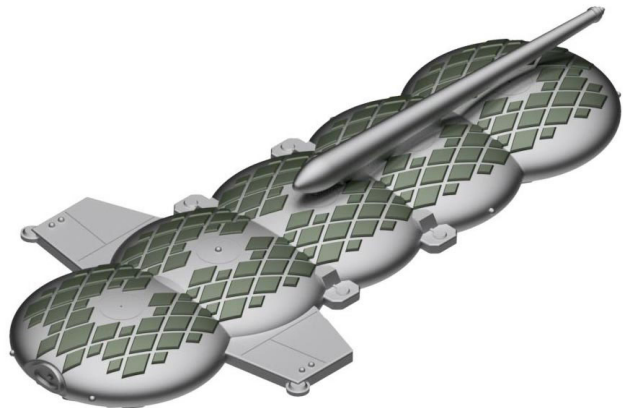

Ultimately, several issues arose to defeat the concept. The most critical was that four of the five "bubbles" would have been entirely new designs, and the cost of starting four new assembly lines was excessive. While it was anticipated that it would tie up tugs to bring together the components in a slipway large enough to accommodate a dreadnought in any case, the capital system had more than enough harbor (R1.50) and salvage (R1.49) tugs for that purpose. However, scheduling the conversion of the smaller slipways to build the elements proved much more daunting. The need for frigates did not really end (at least not before the Andromedan War did), and those slipways were also used to produce destroyers (R6.4) and battle destroyers (R6.19), as well as to refit and refurbish those ships. The result was that the arrival of components to assemble a dreadnought would find another dreadnought already occupying the larger slip, either itself under construction, repair, or refit. The Confederation's logistics command reported that it simply would not be able to accommodate the proposal.

Still, the design did fly in the academy's simulators, where it was discovered that the bubbles' small contact areas (where they were hard-welded together) were extremely vulnerable to stress when the ship executed high energy turns, significantly more so than standard construction dreadnoughts. This problem was, however, not deemed to be especially significant since no one in his right mind would try a high energy turn with the normal dreadnought either. The design envisioned four separate shuttle bays (two of which would carry ground assault shuttles) to be constructed in the hollows between pods, but the number of deck crews was not increased (J4.814), which made shuttle operations difficult under combat operations. A proposal to have the ship carry one gunboat leader (dubbed the "Admiral's gig") on a mech-link was abandoned as there were too few such boats to divert one to such a purpose. Although like any ship in the simulator the mech-link refit (R1.R1) might be applied allowing two casual gunboats to be carried.

Note the rear-firing restriction on the 360° phasers.
Federation reporting name: Pentaceratops.

This ship, while a design assembled from a combination of modified bubble sections of the dreadnought (R6.11), is considered to be a unique base hull. There are no variants.

Four shuttle bays; transfers by (J1.59) are not possible.

Balcony positions: None.

Shuttles: Two admin shuttles [(J2.0)/(R1.F1)] and two ground assault shuttles (R1.F4); these shuttles are included in the ship's BPV.

Seeking weapons: This ship can control a number of seeking weapons equal to its sensor rating (F3.21).

Refits: The design included the plus refit, the F-refit, and the carronade refit. The sabot refit was included in the design but is shown separately for those who do not have *Module R10*.

This ship originally appeared in *Star Fleet Times #33*. Using it in a game requires permission from the opponent's girlfriend (or other potentially bribable person designated by the opponent).

Designed by John Hall.

Status: Unbuilt design.

SSD is in *April Fool's Day Ship Pack 2018*; use any available Gorn ship counter.

Known names: *Penticon, Five-Star*.

(R7.J8) THOLIAN HEXAGONAL BATTLESHIP (CTB): As the General War dragged on, ships got bigger and fleet battles got deadlier. Frigates disappeared from battle formations as the enemy fleet could vaporize them in a single volley. Every empire looked into many pathways that led to bigger ships. While the Tholians were no exception, they were constrained by a shipyard that produced only patrol corvette (R7.2) hulls and various combinations of them.

Told to look into every option, the Tholian shipyard came up with (among others) the hexagonal battleship, basically three Tholian web caster command cruisers (CCWs) (R7.67) connected together in a ring that looked more like six patrol corvettes (PCs) than three cruisers, but the effect was the same. The problem was that the need for two of each section's three wings to be used for structural connection meant that the ship had to rely on six engines on the remaining outside fin. The only engines available were the original patrol corvette engine and the boosted destroyer engine (R7.4). Six destroyer engines were found to provide sufficient power, although the ship would not be able to attain maximum battle speed.

The Tholians never built one of these ships because the opportunity cost (three cruisers and two destroyers) was too high to pay. The fleet was better off with the five smaller ships. There was also the problem that while the largest access port of the Holdfast Dyson sphere (as indeed such large access ports on every Tholian Dyson sphere) could accommodate a Neo-Tholian battleship (R7.60), it would not be able to accommodate this ship. The problem being that while the design was much shorter than the battleship, it was also much "taller," and it was impossible to modify the access port to accommodate the design. The Tholians did produce a mock-up structure the size of the theoretical Crown battleship, but this was intended to attract the attention of spies and perhaps lure an enemy fleet into attacking a highly defended area. The mock-up included six Arachnid (R7.PF1) gunboats.

The ship's repair systems can only be used to repair fast patrol ships (K2.611) and can only repair those on the two positions adjacent to the repair systems using collapsible repair bays (K2.63). Each is independent; repair points generated by the repair systems can only be used on an Arachnid PF (R7.PF1) on the adjacent mech link.

This ship, while a design assembled from a combination of web caster command cruisers (R7.67), is considered to be a unique base hull. There are no variants. It could be built from scratch rather than using existing cruisers, but this would be under the (436.2) battleship construction rules of *F&E*.

Carrier: This ship is a true carrier; see (J4.75), (J4.93), (J10.111), (J11.13), and (J15.22).

PF tender: This ship is a true PF tender (K2.0) and cannot operate heavy fighters (J10.0).

This ship has three shuttle bays; two each holding two Spider-IIs and two Spider-IIIs and one holding four admin shuttles [(J2.0)/(R1.F1)]. One or two multi-role shuttles (J8.0) would have been provided if they were available, replacing admin shuttles; this is not included in the ship's BPV. Transfers between the bays are not possible under (J1.59). There are no balcony (J1.53) positions, launch tubes (J1.54), or external bays (J1.55).

| Year | Escorts | Fighters |
|-------|---------|------------------------------|
| Y184+ | None | 4xSpider-II and 4xSpider-III |

Landing: This ship cannot land on planets by the gravity (P2.432) landing systems and does not have the crash landing bonus (P2.4311).

Cargo packs: The hexagonal battleship can carry cargo packs (R7.14), but because of its design it can only carry six cargo packs, or no cargo packs. If carrying six cargo packs its movement cost is increased to three. The packs, if carried, block the firing arcs of disruptors G, H, J, K, L, and M.

Refits: The design included DERFACS and the web caster refit. The snare refit would probably have been installed, but is shown separately on the SSD.

This ship originally was suggested on ADB's BBS. Further research resulted in this design. Using it in a game requires permission from the opponent's girlfriend (or other potentially bribable person designated by the opponent).

Suggested by Steven Zamboni.

Status: Unbuilt design.

SSD is in *April Fool's Day Ship Pack 2018*; use any available Tholian ship counter.

Known names: *Crown of Tholia*. An Orion spy who claimed to have seen the ship described it as "the crown of Tholia" and the name, picked up by Federation intelligence, stuck. What the Tholians called it is not known.

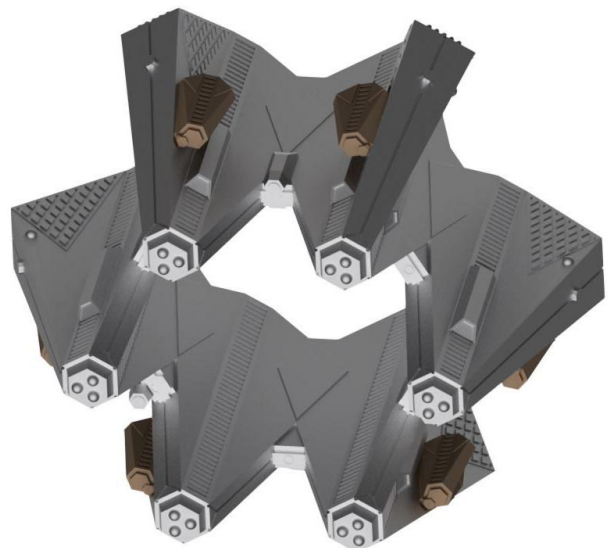

(R12.J12) WYN AUXILIARY HEAVY MAULER (AxHM): The auxiliary heavy mauler may be one of the great myths of the WYN Cluster. The story goes that after the Inter-Stellar Concordium and Andromedan incursions, the post-Usurper government built this ship to block any further intrusions. Generally it is believed that the ship was never built [given the troubles of the *Nancy* (R12.16)], but the Cluster remains very tight-lipped and at best “neither confirms or denies” the existence of this ship.

The design used type-C (FD3.3) drone racks instead of the more familiar type-B (FD3.2) drone racks because it was intended to get close, stay close, and destroy its target. Only large battery banks were used as the ship was intended to kill large warships before they could recover from the effects of passage through the WYN radiation zone (P7.0). Analysts believed the ship would suffer from all the mechanical problems of the *Nancy* (R12.16), and might be a final conversion of that ship after it failed as an auxiliary battle control ship (R12.17).

The engines, batteries, and APRs are all tied into the mauler (E8.0). Any power system tied to the mauler system can be destroyed on an “any weapon” (D4.324) damage point (E8.13).

Shock: The auxiliary heavy mauler must roll for shock when firing the mauler; see (D23.22) and (D23.24). When the mauler is fired, one (1) is added to the shock damage die roll for every increment of 20 points of power fired through the mauler after the first 20 in any given period of eight consecutive impulses. For 20 points, no modifier. For 21-40 points +1. For 41-60 points +2, and so on. Shock rating is 10.

This ship is a variant of the auxiliary dreadnought (R12.16).

Deployment: See (S8.43) for deployment restrictions and conditions.

Seeking weapons: This ship can control a number of seeking weapons equal to double its sensor rating (F3.212). The drone racks on this ship were always eight type-C (FD3.3) with two reloads. This ship could always launch drones at the maximum rate of the given drone rack each turn.

Refits: None, the equivalent of the Y175 refit was incorporated in the design.

Maneuver: The auxiliary heavy mauler can accelerate by no more than five movement points or double its current speed. It can disengage by acceleration.

This ship originally appeared in *Star Fleet Times* #40. Using it in a game requires permission from the opponent’s girlfriend (or other potentially bribable person designated by the opponent). In addition, as per (R12.16) the following applies: Players wishing to use this ship in scenarios such as (SG17.0) should assume it will arrive as a reinforcement. The WYN player rolls one die every turn (before Energy Allocation) and keeps a running total. When this total exceeds 40, the ship arrives. Roll one die for each weapon (excluding the mauler system itself) and power-producing (not battery) box on the SSD; those with a die roll of “1” or “2” are treated as “inactive” (G30.0).

Status: Unbuilt Variant.

SSD is in *April Fool’s Day Ship Pack 2018*, use any available WYN ship counter.

Known names: *No No Nanette*. This name appears in Federation records, but like all WYN “female” names, is not a direct translation as individual proper names did not translate.

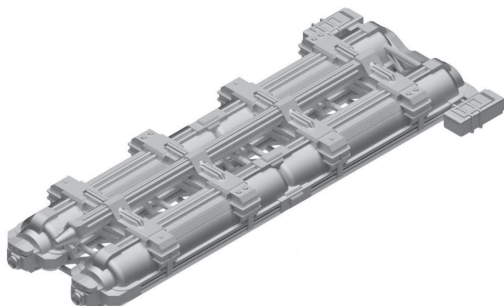

PUBLISHER’S INFORMATION

This project began when Steven Zamboni, one of our sculptors on the Shapeways Project, proposed a set of “April Fool’s ships” which could be offered as miniatures. Since we have printed many “joke” ships over the years and traditionally do *something* for April Fool’s Day, we agreed. Players immediately asked where to get the ship cards, and were not satisfied with word that *SFB* cards were in old issues of *Star Fleet Times* but other game systems would require players to convert that data.

Marketing Director Jean Sexton dealt with the resulting riot by promising we would publish the SSDs. She then told *SFB* Chief Developer Steven P. Petrick to update the old SSDs and give them to *FC* Designer Stephen V. Cole to convert into *FC* ship cards, *ACTA* Chief Developer Tony Thomas to create *ACTA* cards, and *Starmada* Designer Daniel Kast to create *Starmada Unity* cards. From there it was a short step to adding *Star Fleet Battle Force* cards and an *F&E* Ship Information Table.

When management protested that this was too much work for such a minor project, Jean pointed out the marketing value of the only *SFU* product to directly compare ships across all six game systems.

PROJECT STAFF

Project Coordinator Jean Sexton
SFB Chief Developer Steven P. Petrick
FC Designer Stephen V. Cole, PE
A Call to Arms Star Fleet Developer Tony L. Thomas
F&E Designer Stephen V. Cole, PE
Starmada Designer Daniel Kast
SFBF Designer Stephen V. Cole, PE
Business Manager Leanna M. Cole
Graphics Director Simone Dale
Director of Proofreading Jean Sexton
Project Staff Mike West, Chuck Strong, Ryan Opel, Mike Curtis, Thomas Mathews, Mike Sparks, Shawn Hantke.
Security Chief Wolf Sexton
Interior Artist Stephen Zamboni

PUBLISHER’S INFORMATION

Star Fleet Universe April Fool’s Pack 2018 was created and published by Amarillo Design Bureau, Inc., P.O. Box 8759, Amarillo, TX 79114. Contact ADB, Inc. to order spare parts (or to obtain a list), replacement of defective or missing parts, or anything relating to *Star Fleet* products. Include a stamped self-addressed envelope. This product copyright © 2018 Amarillo Design Bureau, Inc.; all rights are reserved under the Pan-American, International, and Berne Copyright Conventions.

All rules questions and submissions of new material should be sent to ADB, Inc., Post Office Box 8759, Amarillo, TX 79114. Include a stamped self-addressed envelope if you wish a reply. You may also use email; contact design@starfleetgames.com before sending submissions by email. Unsolicited submissions are accepted only under the standard terms found on our website and become the property of ADB, Inc. on receipt; but authors are compensated if the item is published. Others should inquire by letter.

No materials based on, for use with, or incorporating elements of any *Star Fleet Universe* products may be published without permission of ADB, Inc.

Elements of the *Star Fleet Universe*
are the property of

Paramount Pictures Corporation
and are used with their permission.

www.StarFleetGames.com

| STR FLEET BATTLES MASTER SHIP CHART FOR APRIL FOOL'S PACK #2018 | | | | | | | | | | | | | | | | |
|---|-----------|-----------------|----------------|----------|-----------------|-----------------|----------------------|-----------------|----------------|-------------|-----------------|-------------------|----------------------|-----------------|------------------|---------------------|
| Empire | Ship Type | G9.0 Crew Units | D7.0 Brdg Prts | S2.1 BPV | C6.5 Break Down | C2.12 Move Cost | J1.42 Spare Shuttles | R0.6 Size Class | C3.3 Turn Mode | Rule Number | Year In Service | C13.3 Dock Points | D5.2 Explos Strength | War Ship Status | F&E Cmand Rating | Notes |
| Kzinti | TRI | 40 | 16 | 170 | 3-6 | 1.00 | 2 | 3 | E | J9 | 177 | 9 | 22 | UNV | 8 | |
| Gorn | BDN | 66 | 30 | 229 | 2-6 | 1.50 | 1+1G | 2 | E | J12 | 182 | 12 | 28 | UNV | 10 | |
| Gorn | BDN | 66 | 30 | 239 | 2-6 | 1.50 | 1+1G | 2 | E | J12 | 182 | 12 | 28 | UNV | 10 | R Sabot Refit |
| Tholian | CTB | 86 | 24 | 406 | 2-6 | 2.00 | 1+1+1 | 2 | E | J8 | 184 | N/A | 42 | UNV | 10 | V, P |
| Tholian | CTB | 86 | 24 | 400 | 2-6 | 2.00 | 1+1+1 | 2 | E | J8 | 184 | N/A | 42 | UNV | 10 | V, P, R Snare Refit |
| WYN | AxHM | 44 | 12 | 300 | 2-6 | 1.00 | — | 3 | E | J12 | 190 | 27 | 52 | UNV | 6 | S, + |

MASTER SHIP CHARTS

STAR FLEET BATTLES: Ships in this game have an entry on the chart at left. This entry provides quick access to information from the ship description and sometimes contains information that is not available anywhere else. The *Master Ship Chart* is thus an integral part of the “rules” for the game. For that matter, so is the “Ship description file” which includes hard rules data as well as historical background and other information such as which product the ship was published in.

FEDERATION COMMANDER: This game has a “reference ship chart” but it is not specifically needed to play the game and is primarily a means of finding out which product the ship is in.

STARMADA: This game does not use any equivalent of a “master ship chart.”

A CALL TO ARMS STAR FLEET: This game does not use any equivalent of a “master ship chart.”

STAR FLEET BATTLE FORCE: This game does not use any equivalent of a “master ship chart.”

FEDERATION & EMPIRE: This game uses a “Ship Information Table” which provides certain information which is available nowhere else. It is thus an integral part of the rules, and updated SITs are on the BBS in a special topic. In particular, the SIT (see at right) lists the turn of the game (the year in history) that the ship can be built, the cost to build it or convert it from something else, the salvage value (money you get back when it is destroyed), and certain notes and special definitions.

SHAPEWAYS

As noted, this project began as our April Fool’s release in our shop on Shapeways. For people who haven’t heard of Shapeways, it is a platform that provides 3D printing services for its makers. By using this platform, ADB is able to provide ships that you want in a material that you like. If you want to paint minis to play with and don’t want to stress over other people handling them roughly (or even dropping them!), there’s a material for you. Do you lavish time and effort on your minis and want them admired? There’s also a material that lends itself to that. Is painting not your thing, but you want green Romulan ships to face orange Tholian ships? That can also be done.

While the metal miniatures will continue to be sold, there won’t be any new ships made as all commercially viable types have been made. On Shapeways, however, we can and have offered variants including scouts, carriers, and escorts among others. We have even offered over 100 Omega sector ships. Fighters and gunboats can be bought in sprues. Ships are available in 3788 scale (Starline 2400 and 2450) and 3125 scale (Starline 2500), or sometimes in Omni scale (Starline 2425). You can find all the April 1 ships in this category:

<https://www.shapeways.com/shops/amarillo-design-bureau-inc?section=April+1+Ships&s=0>

Be sure to visit our shop frequently as we add ships and more empires every month!

<https://www.shapeways.com/shops/amarillo-design-bureau-inc>

| F&E SHIP INFORMATION TABLE FOR SHIPS IN APRIL FOOL'S PACK 2018 | | | | | | | | | | |
|--|-------|---------------------|------------|----|------|---------|-------------------------------|----------------------------|-------|--|
| Designation | Ref # | Factors | Prod | CR | Year | Hull | Conversion Cost | Build Cost | Salv | Notes |
| Kzinti TRI | J9 | 10-9/5 | AFDSP 2018 | 8 | Y177 | TRI(3) | From 2xDW+FF: 4 | For CA: 10 | 2.750 | Tri-maran cruiser built from two DWs and one FF. |
| Gorn BDN | J12 | 14/7 | AFDSP 2018 | 10 | Y182 | BDN(2) | For 4xAuxPod: 20 | For DN: 18 For 5xDD: 18 | 4.500 | Bubble dreadnought made from five bubbles with no hull per se. |
| Tholian CTB | J8 | 24PW(4)/ 12PW(2) | AFDSP 2018 | 10 | Y184 | CTB(2) | From 3xCCW: 10+8+1 | (436.2): 47+8+1 | 9.000 | Hexagonal battleship, built from three CCWs with DD engines. It can function as a PFT. |
| WYN Aux HM | J12 | 16-14+7 | AFDSP 2018 | 6 | Y190 | HAux(3) | From HAux: 14 from HAC: 13 | For 4xAuxPod: 20 | 9.000 | Auxiliary heavy mauler, cannot leave WYN. Shock 5-6, cannot maul formation. |

CREW UNITS

| | | | | | | | | | | |
|------|--|--|--|--|--|--|--|--|--|--|
| * 10 | | | | | | | | | | |
| 20 | | | | | | | | | | |
| 30 | | | | | | | | | | |
| 40 | | | | | | | | | | |
| 50 | | | | | | | | | | |
| 60 | | | | | | | | | | |

ADMINISTRATIVE SHUTTLES

| IDENT | HIT POINTS | NOTES |
|-------|------------|-------|
| | A | A |
| | A | A |
| | A | A GAS |
| | A | A GAS |
| | A | A GAS |

FOUR BAYS, NO (J159) TRANSFERS.
HIT POINTS MARKED "A" ARE ONLY USED WHEN OPERATING ADVANCED SHUTTLES AFTER Y179: SEE (J17.0) IN MODULE J2.

BOARDING PARTIES

| | | | | | | | | | |
|----|--|--|--|--|--|--|--|--|--|
| 10 | | | | | | | | | |
| 20 | | | | | | | | | |
| 30 | | | | | | | | | |

TRANSPORTER BOMBS

| | | | | | | | | | |
|---|---|---|---|---|---|---|---|---|---|
| D | D | D | D | D | D | D | D | D | D |
|---|---|---|---|---|---|---|---|---|---|

PROBES

| | | | | | | | | | |
|---|--|--|--|--|--|--|--|--|--|
| 5 | | | | | | | | | |
|---|--|--|--|--|--|--|--|--|--|



FA = LF + RF
RA = LR + RR
LS = LF + L + LR
RS = RF + R + RR
SEE (FP8.35) FOR PLASMA BOLT FIRING ARCS.

PLASMA CARRONADES ARE IN MODULE R10: SEE (FP14.0), SEE (FP14.37) FOR FIRING ARCS.

PLASMA CARRONADE

| DIE DAMAGE | TURN MODE | SPEED |
|------------|-----------|-------|
| 1 4 | E 1 | 2-3 |
| 2 4 | 2 | 4-6 |
| 3 4 | 3 | 7-10 |
| 4 4 | 4 | 11-14 |
| 5 3 | 5 | 15-20 |
| 6 3 | 6 | 21-29 |
| 7 2 | 7 | 30+ |

THE SABOT REFIT ALLOWS THE USE OF SPEED-40 TORPEDOES: SEE (FP11.0) IN MODULE R10.

PSEUDO-PLASMA TORPEDOES

| | | | | | | | | | |
|---|---|---|---|---|---|---|---|---|---|
| A | R | B | S | C | S | D | F | E | F |
|---|---|---|---|---|---|---|---|---|---|

TYPE I OFFENSIVE PHASER TABLE

| DIE RANGE ROLL | 0-5 | 6-10 | 11-12 | 13-14 | 15 | 16-18 | 19 | 20 | 21-23 | 24 | 25 | 26-28 | 29 | 30 |
|----------------|-----|------|-------|-------|----|-------|----|----|-------|----|----|-------|----|----|
| 1 | 9 | 8 | 7 | 6 | 5 | 5 | 4 | 3 | 2 | 1 | 1 | 1 | 1 | 1 |
| 2 | 8 | 7 | 6 | 5 | 4 | 3 | 2 | 1 | 1 | 0 | 0 | 0 | 0 | 0 |
| 3 | 7 | 5 | 4 | 4 | 4 | 3 | 1 | 0 | 0 | 0 | 0 | 0 | 0 | 0 |
| 4 | 6 | 4 | 4 | 4 | 3 | 2 | 0 | 0 | 0 | 0 | 0 | 0 | 0 | 0 |
| 5 | 5 | 4 | 4 | 4 | 3 | 3 | 1 | 0 | 0 | 0 | 0 | 0 | 0 | 0 |
| 6 | 4 | 4 | 3 | 3 | 2 | 2 | 0 | 0 | 0 | 0 | 0 | 0 | 0 | 0 |

TYPE III DEFENSE PHASER

| DIE RANGE ROLL | 0 | 1 | 2 | 3 | 8 | 15 |
|----------------|---|---|---|---|---|----|
| 1 | 4 | 4 | 4 | 3 | 1 | 1 |
| 2 | 4 | 4 | 4 | 2 | 1 | 0 |
| 3 | 4 | 4 | 4 | 1 | 0 | 0 |
| 4 | 4 | 4 | 3 | 0 | 0 | 0 |
| 5 | 4 | 3 | 2 | 0 | 0 | 0 |
| 6 | 3 | 3 | 1 | 0 | 0 | 0 |

PLASMA TORPEDO WARHEAD STRENGTH TABLE

| RANGE | 0-5 | 6-10 | 11-12 | 13-14 | 15 | 16-18 | 19 | 20 | 21-23 | 24 | 25 | 26-28 | 29 | 30 |
|--------|-----|------|-------|-------|-----|-------|----|----|-------|----|----|-------|----|----|
| TYPE R | 50 | 35 | 35 | 35 | 25 | 25 | 25 | 20 | 20 | 20 | 10 | 5 | 1 | 0 |
| TYPE S | 30 | 22 | 22 | 22 | 15 | 15 | 15 | 10 | 5 | 1 | 0 | 0 | 0 | 0 |
| TYPE G | 20 | 15 | 15 | 15 | 10 | 5 | 1 | 0 | 0 | 0 | 0 | 0 | 0 | 0 |
| TYPE F | 20 | 15 | 10 | 5 | 1 | 0 | 0 | 0 | 0 | 0 | 0 | 0 | 0 | 0 |
| BOLT | 1-4 | 1-3 | | | 1-2 | | | | | | | | | |

WARP ENERGY MOVEMENT COST = 1 + 1/2 ENERGY POINT PER HEX **5** = HET COST

| SPEED | 1 | 2 | 3 | 4 | 5 | 6 | 7 | 8 | 9 | 10 | 11 | 12 | 13 | 14 | 15 | 16 | 17 | 18 | 19 | 20 | 21 | 22 | 23 | 24 | 25 | 26 | 27 | 28 | 29 | 30 |
|----------|-------|---|-------|---|-------|---|--------|----|--------|----|--------|----|--------|----|--------|----|--------|----|--------|----|--------|----|--------|----|--------|----|--------|----|--------|----|
| Standard | 2 | 3 | 5 | 6 | 8 | 9 | 11 | 12 | 14 | 15 | 17 | 18 | 20 | 21 | 23 | 24 | 26 | 27 | 29 | 30 | 32 | 33 | 35 | 36 | 38 | 39 | 41 | 42 | 44 | 45 |
| Fract. | 1 1/2 | 3 | 4 1/2 | 6 | 7 1/2 | 9 | 10 1/2 | 12 | 13 1/2 | 15 | 16 1/2 | 18 | 19 1/2 | 21 | 22 1/2 | 24 | 25 1/2 | 27 | 28 1/2 | 30 | 31 1/2 | 33 | 34 1/2 | 36 | 37 1/2 | 39 | 40 1/2 | 42 | 43 1/2 | 45 |

GORN BUBBLE DREADNOUGHT

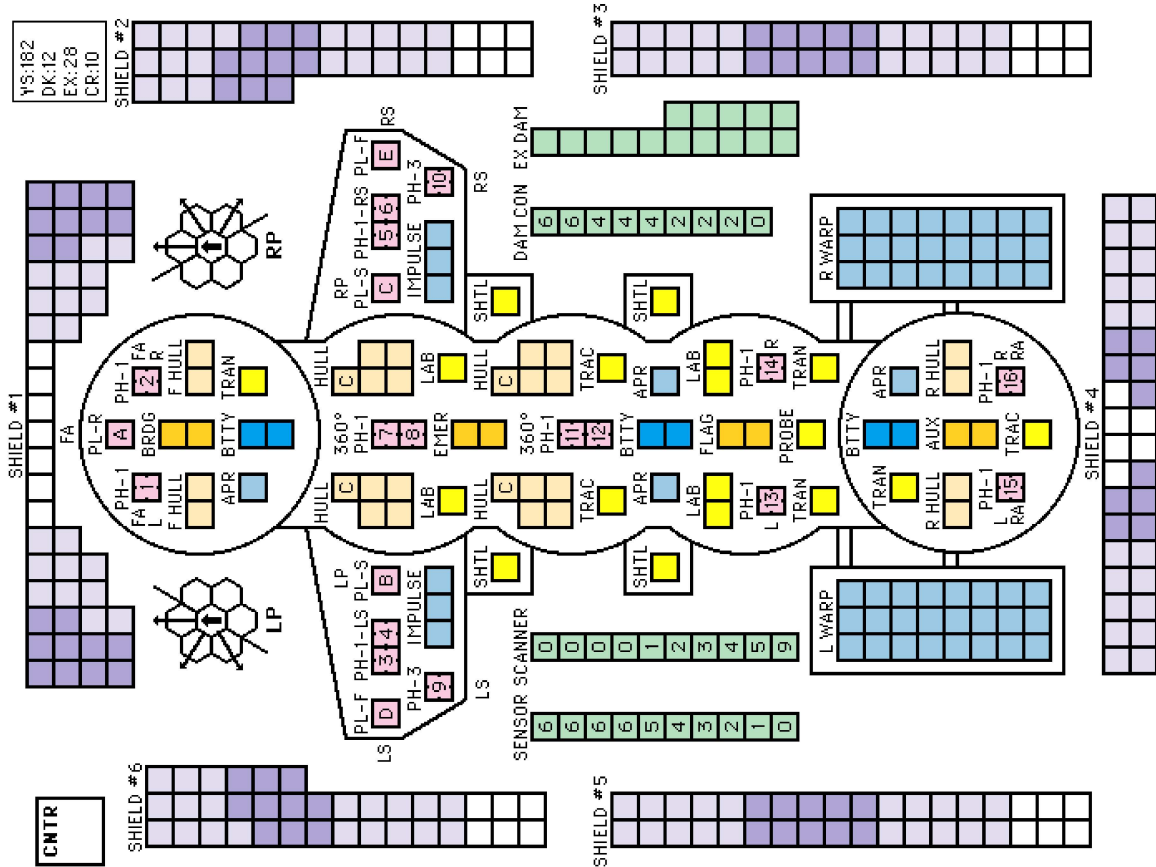

360° PHASERS #7, #8, #11, AND #12 CANNOT FIRE INTO THE ROW OF HEXES EXTENDING DIRECTLY BEHIND THE SHIP.

6 = ERRATIC MANEUVER WARP COST

YS:184
DK:NA
EX:42
CR:10

THOLIAN HEXAGONAL BATTLESHIP CROWN OF THOLIA

CNTR

| TURN MODE | SPEED |
|-----------|---------|
| E | 1 2-3 |
| | 2 4-6 |
| | 3 7-10 |
| | 4 11-14 |
| HET | 5 15-20 |
| | 6 21-29 |
| BD | 7 30+ |

| SHIP DATA TABLE |
|----------------------|
| TYPE = CTB |
| POINT VALUE = 400 |
| BREAKDOWN = 2-6 |
| SHIELD COST = 1+3 |
| LIFE SUPPORT = 1+1/2 |
| SIZE CLASS = 2 |
| REFERENCE = R7.J8 |
| SNARE REFIT |
| (Y184) = +6 |

| ADMINISTRATIVE SHUTTLES | HIT POINTS | NOTES |
|-------------------------|------------|-------|
| | 10 | A A |
| | 20 | A A |
| | 30 | A A |
| | 40 | A A |
| | 50 | A A |
| | 60 | A A |
| | 70 | A A |
| | 80 | A A |

FOUR BAYS, NO (J159) TRANSFERS.
HIT POINTS MARKED "A" ARE ONLY USED WHEN OPERATING ADVANCED SHUTTLES AFTER Y179; SEE (J17.0) IN MODULE J2.

| TRANSPORTER BOMBS |
|-------------------|
| D D D D D D D D |

| BOARDING PARTIES |
|------------------|
| 10 |
| 20 |

| DECK CREWS |
|------------|
| 8 |

| PROBES |
|--------|
| 5 |



HIT & RUN DERFACS
FA = LF + RF
RA = LR + RR
RX = L + LR + RR + R

| WEB CASTER STRENGTH TABLE | | | | | |
|-------------------------------|-----|----|----|----|----|
| ENERGY # OF WEB HEXES CREATED | 1 | 2 | 3 | 4 | 5 |
| 1-2-3 | 10 | 5 | 3 | 2 | 2 |
| 2-3-4 | 20 | 10 | 6 | 5 | 4 |
| 3-4-5 | 30 | 15 | 10 | 7 | 6 |
| 4-5-N | 35* | 20 | 13 | 10 | 8 |
| 5-N-N | 35* | 25 | 16 | 12 | 10 |

| TYPE III DEFENSE PHASER | |
|-------------------------|------------|
| DIE RANGE | 4-9 |
| ROLL 0 | 1 2 3 8 15 |
| 1 | 4 4 3 1 1 |
| 2 | 4 4 2 1 0 |
| 3 | 4 4 1 0 0 |
| 4 | 4 3 0 0 0 |
| 5 | 4 3 2 0 0 |
| 6 | 3 1 0 0 0 |

| TYPE I OFFENSIVE PHASER TABLE | | | |
|-------------------------------|-------------------------|-------|-------|
| DIE RANGE | 6-9 | 16-26 | 51-75 |
| ROLL 0 | 1 2 3 4 5 8 15 25 50 75 | | |
| 1 | 9 8 7 6 5 5 4 3 2 1 1 | | |
| 2 | 8 7 6 5 4 4 3 2 1 0 0 | | |
| 3 | 7 5 4 4 4 3 1 0 0 0 | | |
| 4 | 6 4 4 4 4 3 2 0 0 0 | | |
| 5 | 5 4 4 4 3 3 1 0 0 0 | | |
| 6 | 4 4 3 3 2 2 0 0 0 0 | | |

REPAIR IS DESTROYED ON "CARGO" DAMAGE POINTS.
⑤ = HET COST ⑥ = EM WARP COST

| WARP ENERGY MOVEMENT COST = 2 | |
|-------------------------------|---|
| SPEED | 1 2 3 4 ⑤ 7 8 9 10 11 12 13 14 15 16 17 18 19 20 21 22 23 24 25 26 27 28 29 30 |
| COST | 2 4 6 8 10 12 14 16 18 20 22 24 26 28 30 32 34 36 38 40 42 44 46 48 50 52 54 56 58 60 |

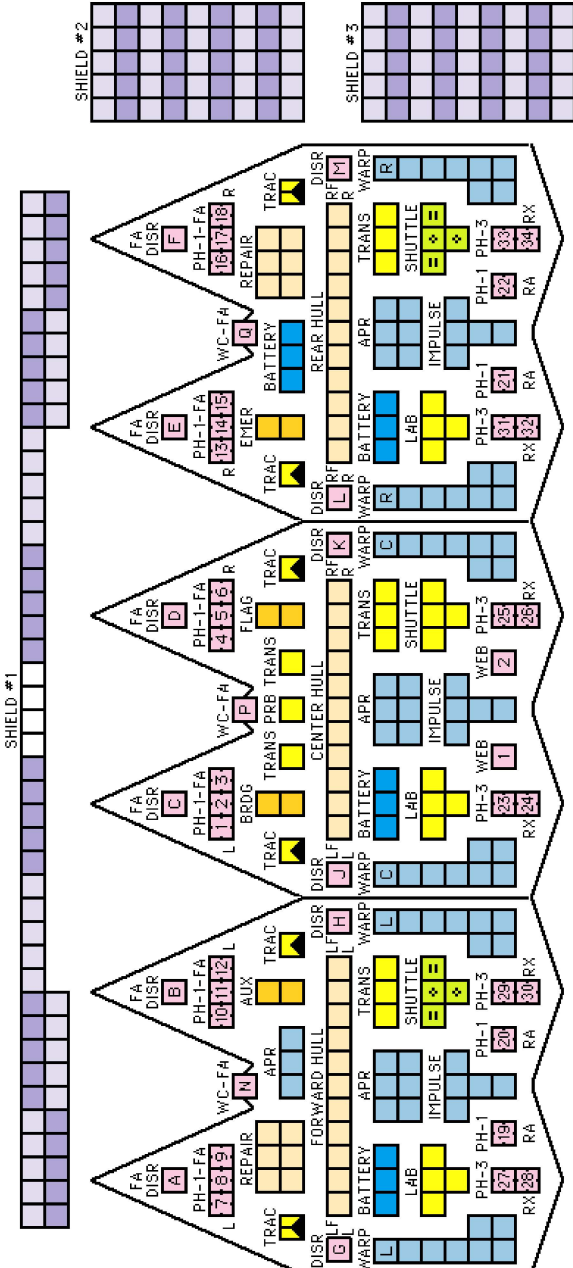

| SPIDER II |
|---------------|
| 1xPh-3-360° |
| DFR = 3 |
| CRIPPLED = 10 |
| SPEED = 14 |
| BPV = 9 |

| SPIDER IIF |
|---------------|
| 1xPh-5-360° |
| DFR = 3 |
| CRIPPLED = 10 |
| SPEED = 14 |
| BPV = 11 |

| SPIDER III |
|---------------|
| 2xPh-3-FA |
| DFR = 4 |
| CRIPPLED = 10 |
| SPEED = 15 |
| BPV = 6 |

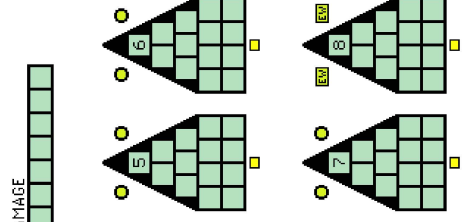

| DISRUPTOR TABLE | | | | | | | | | |
|-----------------|-----|-----|-----|-----|-----|------|-------|-------|-------|
| RANGE | 0 | 1 | 2 | 3-4 | 5-8 | 9-15 | 16-22 | 23-30 | 31-40 |
| HIT (STD) | NR | 1-5 | 1-4 | 1-4 | 1-4 | 1-4 | 1-3 | 1-2 | 1-2 |
| HIT (DERFACS) | NR | 1-5 | 1-4 | 1-4 | 1-4 | 1-4 | 1-3 | 1-2 | 1-2 |
| HIT (OVERLOAD) | 1-6 | 1-5 | 1-4 | 1-4 | 1-4 | NR | NR | NR | NR |
| DAMAGE STD | 0 | 5 | 4 | 4 | 3 | 3 | 2 | 2 | 1 |
| DAMAGE OULD | 10 | 10 | 8 | 8 | 6 | 6 | 0 | 0 | 0 |

| WEB FIST TABLE | | | |
|----------------|------|-------|-------|
| RANGE | 1-10 | 11-20 | 21-30 |
| HIT | 1-4 | 1-3 | 1-2 |
| MISS | 5-6 | 4-6 | 3-6 |
| ENERGY | 2 | 0 | 0 |
| DAMAGE | 4 | 2 | 0 |
| | 3 | 6 | 4 |
| | 8 | 6 | 4 |
| | 10 | 8 | 6 |

| DISRUPTOR TABLE | | | | | | | | | |
|-----------------|-----|-----|-----|-----|-----|------|-------|-------|-------|
| RANGE | 0 | 1 | 2 | 3-4 | 5-8 | 9-15 | 16-22 | 23-30 | 31-40 |
| HIT (STD) | NR | 1-5 | 1-4 | 1-4 | 1-4 | 1-4 | 1-3 | 1-2 | 1-2 |
| HIT (DERFACS) | NR | 1-5 | 1-4 | 1-4 | 1-4 | 1-4 | 1-3 | 1-2 | 1-2 |
| HIT (OVERLOAD) | 1-6 | 1-5 | 1-4 | 1-4 | 1-4 | NR | NR | NR | NR |
| DAMAGE STD | 0 | 5 | 4 | 4 | 3 | 3 | 2 | 2 | 1 |
| DAMAGE OULD | 10 | 10 | 8 | 8 | 6 | 6 | 0 | 0 | 0 |

SNARE REFIT ALLOWS BOTH WEB GENERATORS TO OPERATE AS WEB SNARES; SEE (E13.3) IN MODULE C2.
WEB GENERATORS ARE DESTROYED ON "FLAG" HITS.

KZINTI TRIMARAN CRUISER

FLEET SCALE



COUNTER **TRI**
 POINT VALUE: 94
 DAMAGE CONTROL: 2

POWER TRACK
 22
 21
 20
 19
 18
 17
 16
 15
 14
 13
 12
 11
 10
 9
 8
 7
 6
 5
 4
 3
 2
 1
 0

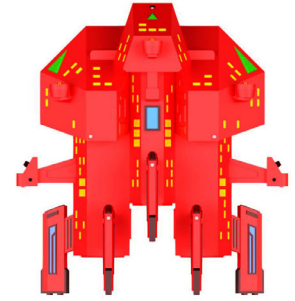

KHS _____
 Name

PROBES

| | | | | |
|--|--|--|--|--|
| | | | | |
|--|--|--|--|--|

MARINES

| | | | |
|---|--|--|--|
| 8 | | | |
| 4 | | | |

FRAME DAMAGE

| | | |
|---|--|--|
| 3 | | |
|---|--|--|

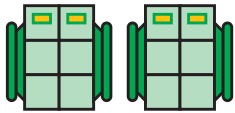

WEAPONS USED

| | | | | |
|---|---|---|---|---|
| A | B | | | |
| 1 | 2 | 3 | 4 | 5 |
| X | Y | Z | | |

- TURN MODE E
MOVE COST 1/2
- BASE SPEED 8
TURN MODE 3
SPEED COST 4
- BASE SPEED 16
TURN MODE 5
SPEED COST 8
- BASE SPEED 24
TURN MODE 6
SPEED COST 12
- ACCELERATION
COST 1/2
- DECELERATION
COST 1/2
- HIGH ENERGY
TURN COST = 2+1/2
- EVASIVE
MANEUVER
COST = 3

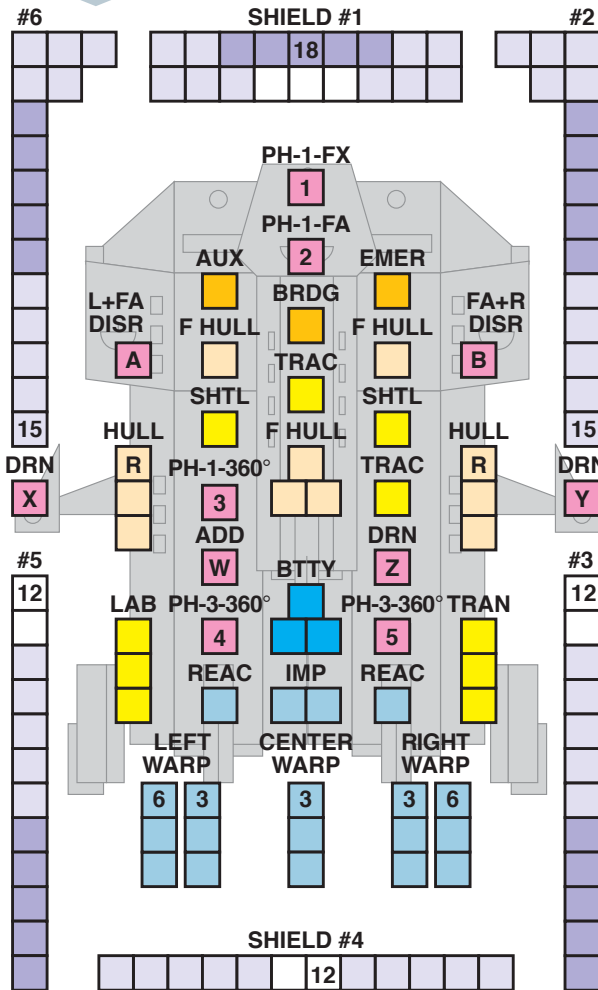

This ship can control up to 6 drones at one time.

| DRONES | ANTI-DRONE RACK W | DRONE RACK |
|--------|-------------------|------------|
| 1 | | X |
| 2 | | Y |
| 3 | | Z |
| 4 | | |
| 5 | | |
| 6 | | |

ANTI-DRONE W:
IMPULSE USED

| | | | | | | | |
|---|---|---|---|---|---|---|---|
| 1 | 2 | 3 | 4 | 5 | 6 | 7 | 8 |
|---|---|---|---|---|---|---|---|

AF01 FEDERATION COMMANDER: APRIL FOOL'S 2018
 FLEET SCALE SHIP CARD #AF01
 Copyright © 2018 Amarillo Design Bureau, Inc.

FRACTIONAL POWER
 0 1/2

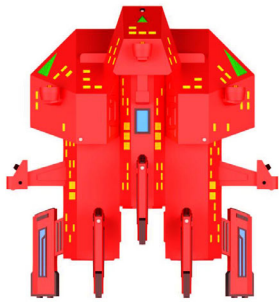

KZINTI TRIMARAN CRUISER

SQUADRON SCALE

COUNTER TRI
 POINT VALUE: 188
 DAMAGE CONTROL: 4

POWER TRACK
 Power when undamaged:
 38 + 6.



KHS
 Name _____

PROBES

| | | | | |
|---|--|--|--|--|
| 1 | | | | |
| 2 | | | | |

MARINES

| | | | | |
|----|--|--|--|--|
| 16 | | | | |
| 12 | | | | |
| 6 | | | | |

FRAME DAMAGE

| | | | | |
|---|--|--|--|--|
| 6 | | | | |
|---|--|--|--|--|

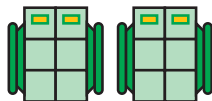

WEAPONS USED

| A | B | C | D | E |
|---|---|---|---|---|
| 1 | 2 | 3 | 4 | 5 |
| 6 | 7 | 8 | 9 | U |
| V | W | X | Y | Z |

TURN MODE E
 MOVE COST 1

BASE SPEED 8
 TURN MODE 3
 SPEED COST 8

BASE SPEED 16
 TURN MODE 5
 SPEED COST 16

BASE SPEED 24
 TURN MODE 6
 SPEED COST 24

ACCELERATION
 COST 1

DECELERATION
 COST 1

HIGH ENERGY
 TURN COST = 5

EVASIVE
 MANEUVER
 COST = 6

AF01

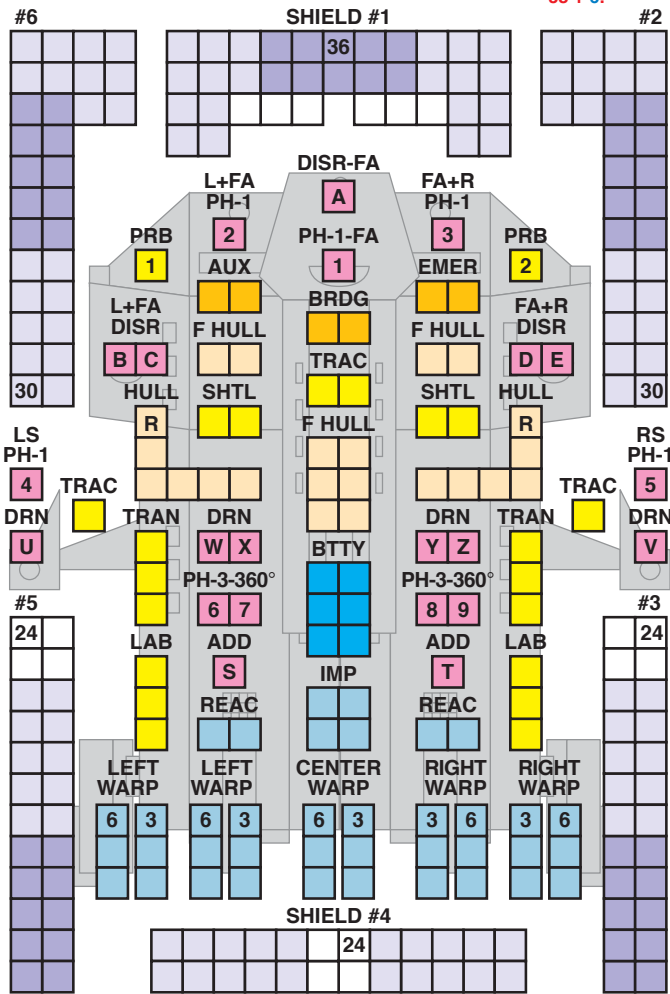

+40
 +30
 +20
 +10
 9
 8
 7
 6
 5
 4
 3
 2
 1
 0

This ship can control up to 12 drones at one time.

ANTI-DRONE RACK

| | | | | | | | | | | | | | | | | | |
|---|--|--|--|--|--|--|--|--|--|--|--|--|--|--|--|--|--|
| S | | | | | | | | | | | | | | | | | |
| T | | | | | | | | | | | | | | | | | |

ANTI-DRONES: IMPULSE USED

| | | | | | | | | |
|---|---|---|---|---|---|---|---|---|
| S | 1 | 2 | 3 | 4 | 5 | 6 | 7 | 8 |
| T | 1 | 2 | 3 | 4 | 5 | 6 | 7 | 8 |

DRONES

| | | | |
|---|--|--|--|
| 1 | | | |
| 2 | | | |
| 3 | | | |
| 4 | | | |
| 5 | | | |
| 6 | | | |

DRONES

| | | | |
|----|--|--|--|
| 7 | | | |
| 8 | | | |
| 9 | | | |
| 10 | | | |
| 11 | | | |
| 12 | | | |

DRONE RACK

| | | | |
|---|--|--|--|
| U | | | |
| V | | | |
| W | | | |

DRONE RACK

| | | | |
|---|--|--|--|
| X | | | |
| Y | | | |
| Z | | | |

FEDERATION COMMANDER: APRIL FOOL'S 2018
 SQUADRON SCALE SHIP CARD #AF01
 Copyright © 2018 Amarillo Design Bureau, Inc.

FRACTIONAL POWER
 0 1/2

CROWN OF THOLIA BATTLESHIP

SQUADRON SCALE



COUNTER CTB
POINT VALUE: 400
DAMAGE CONTROL: 8

TDV Name

PROBES

| |
|----|
| 24 |
| 20 |
| 15 |
| 10 |
| 5 |

WEAPONS USED

| | | | | | | | | | | | | | | | | | |
|----|----|----|----|----|----|----|----|----|----|----|----|----|----|----|----|----|----|
| A | B | C | D | E | F | G | H | J | K | L | M | N | P | Q | | | |
| 1 | 2 | 3 | 4 | 5 | 6 | 7 | 8 | 9 | 10 | 11 | 12 | 13 | 14 | 15 | 16 | 17 | 18 |
| 19 | 20 | 21 | 22 | 23 | 24 | 25 | 26 | 27 | 28 | 29 | 30 | 31 | 32 | 33 | 34 | Y | Z |

FRAME DAMAGE

| | |
|----|---|
| 10 | 5 |
|----|---|

Spider fighters (one Phaser-3-FA and one Phaser-2 FA)

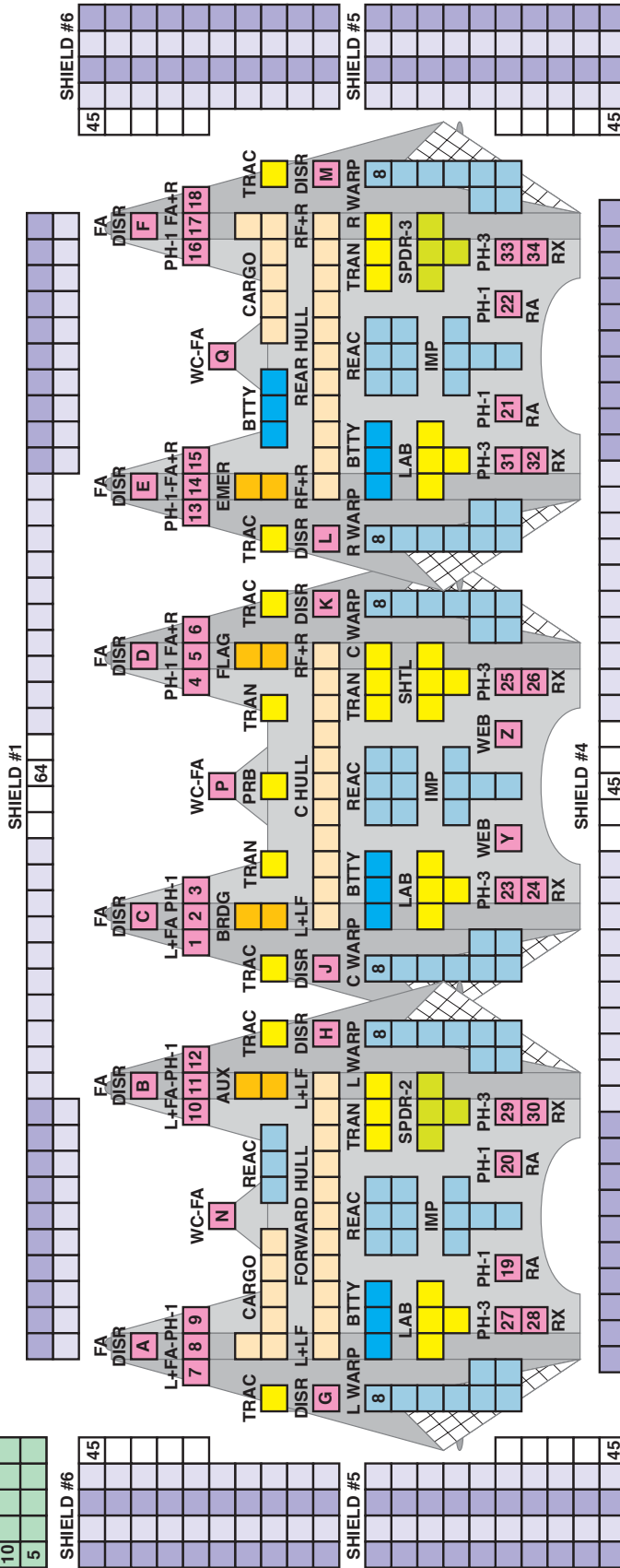
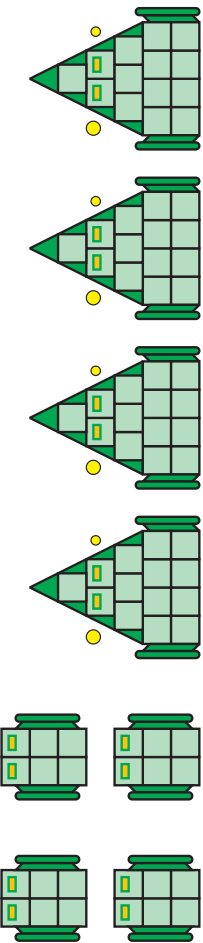

FEDERATION COMMANDER: APRIL FOOL'S 2018
SQUADRON SCALE SHIP CARD #AF02
Copyright © 2018 Amarillo Design Bureau, Inc.



| | |
|---|--------------------------------|
| TURN MODE 2 MOVE COST 2 | ACCELERATION COST 2 |
| BASE SPEED 8 TURN MODE 3 SPEED COST 16 | DECELERATION COST 2 |
| BASE SPEED 16 TURN MODE 5 SPEED COST 32 | HIGH ENERGY TURN COST 10 |
| BASE SPEED 24 TURN MODE 6 SPEED COST 48 | EVASIVE MANEUVER COST 12 |

POWER TRACK
Power when undamaged:
84 + 12 = 96.

+90
+80
+70
+60
+50
+40
+30
+20
+10
9
8
7
6
5
4
3
2
1
0

GORN BUBBLE DREADNOUGHT

FLEET SCALE

COUNTER **BDN**
 POINT VALUE: 115
 DAMAGE CONTROL: 3



POWER TRACK

+30
+20
+10

Power when undamaged:
29 + 3 = 32

PROBES

| | | | |
|--|--|--|--|
| | | | |
|--|--|--|--|

WEAPONS USED

| A | B | C |
|---|---|---|
| 1 | 2 | 3 |
| 4 | 5 | 6 |
| 7 | 8 | 9 |

MARINES

| | | | |
|----|--|--|--|
| 15 | | | |
| 10 | | | |
| 5 | | | |

FRAME DAMAGE

| | | |
|---|--|--|
| 8 | | |
| 4 | | |

PLASMA A

| 50 | 40 | 30 | 20 | 10 |
|----|----|----|----|----|
| | | | | |
| | | | | |
| | | | | |
| | | | | |
| | | | | |
| | | | | |
| | | | | |
| | | | | |
| | | | | |
| | | | | |

TURN MODE E MOVE COST 3/4

BASE SPEED 8
TURN MODE 3
SPEED COST 6

BASE SPEED 16
TURN MODE 5
SPEED COST 12

BASE SPEED 24
TURN MODE 6
SPEED COST 18

ACCELERATION
COST 3/4

DECELERATION
COST 3/4

HIGH ENERGY
TURN COST 3+3/4

EVASIVE
MANEUVER COST 4+1/2

AF03

GCS

Name _____

PLASMA ARMING

| A | B | C | D | E | F | G | S | R |
|---|---|---|---|---|---|---|---|---|
| | | | | | | | | |
| | | | | | | F | | |
| | | | | | F | | | |

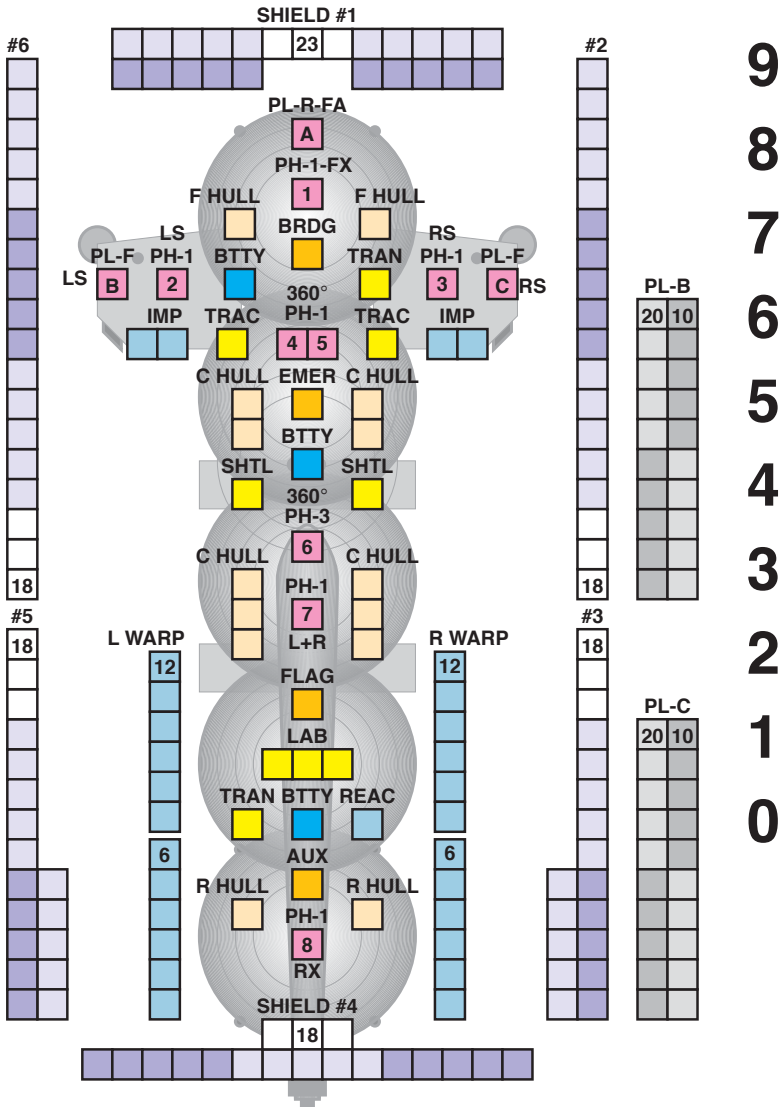

FEDERATION COMMANDER:
 APRIL FOOL'S 2018
 FLEET SCALE SHIP
 CARD AF03
 Copyright © 2018
 Amarillo Design Bureau, Inc.

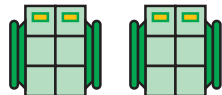

FRACTIONAL POWER

0 1/4 1/2 3/4

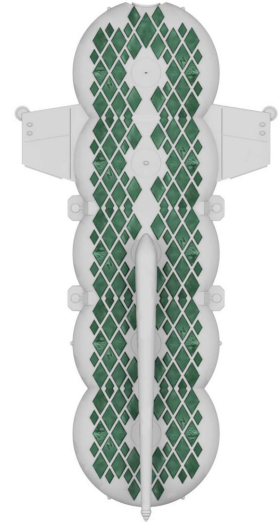

WYN CLUSTER AUXILIARY HEAVY MAULER FLEET SCALE

COUNTER AXHM
POINT VALUE: 162
DAMAGE CONTROL: 3



POWER TRACK

Power when undamaged: 32 + 40 = 72.

+30
+20
+10

WDS _____
Name

This ship has no probe launcher.

MARINES
6

FRAME DAMAGE
3

DRONES

| | | | | | | | | | | | |
|----|--|--|--|--|--|--|--|--|--|--|--|
| 1 | | | | | | | | | | | |
| 2 | | | | | | | | | | | |
| 3 | | | | | | | | | | | |
| 4 | | | | | | | | | | | |
| 5 | | | | | | | | | | | |
| 6 | | | | | | | | | | | |
| 7 | | | | | | | | | | | |
| 8 | | | | | | | | | | | |
| 9 | | | | | | | | | | | |
| 10 | | | | | | | | | | | |
| 11 | | | | | | | | | | | |
| 12 | | | | | | | | | | | |

WEAPONS USED

| | | | | | |
|---|---|---|---|--|--|
| 1 | 2 | | | | |
| 1 | 2 | 3 | 4 | | |
| W | X | Y | Z | | |

TURN MODE E
MOVE COST 1/2

BASE SPEED 8
TURN MODE 3
SPEED COST 4

BASE SPEED 16
TURN MODE 5
SPEED COST 8

BASE SPEED 24
NOT POSSIBLE FOR THIS SHIP

ACCELERATION
COST 1/2

DECELERATION
COST 1/2

HIGH ENERGY
TURN BANNED

EVASIVE
MANEUVER
NOT ALLOWED

AF04

FEDERATION COMMANDER: APRIL FOOL'S 2018
FLEET SCALE SHIP CARD #AF04
Copyright © 2018 Amarillo Design Bureau, Inc.

FRACTIONAL POWER
0 1/2

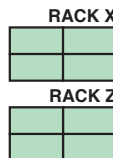
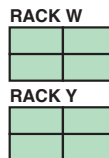
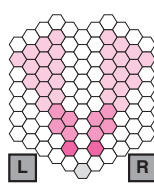
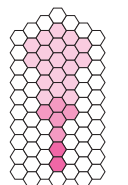
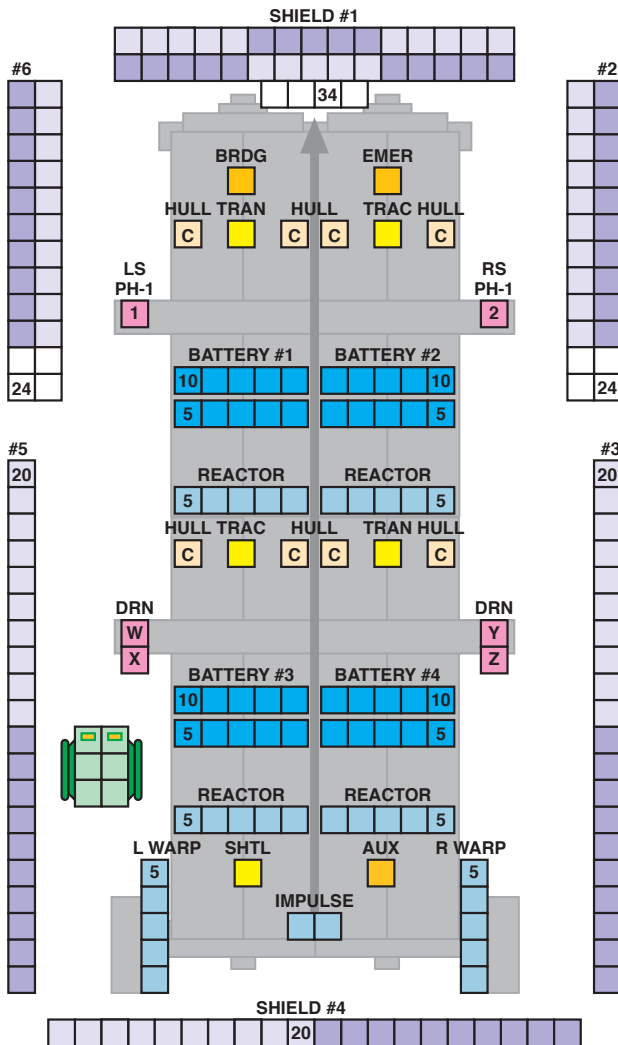

9
8
7
6
5
4
3
2
1
0

+40
+30
+20
+10

9
8
7
6
5
4
3
2
1
0

(4Z) MAULERS FOR FEDERATION COMMANDER

The mauler fires a beam of intense directional energy. Mauler ships have huge battery banks to feed the weapon because of the intense energy requirements, making such ships unsuitable for other missions. The mauler was designed by the Romulans and sold to their Klingon and Lyran allies. How the WYNs got one is unclear.

(4Z1) Weapon: The mauler is shown on the ship card only as a solid black arrow. There is no specific box on the ship card and the mauler itself cannot be damaged. A mauler ship may fire its mauler once per impulse. Damage scored on a mauler ship and allocated to any type of weapon except a phaser can be, but does not have to be, marked on any power system of the ship. (If not so marked, it is treated as a "skip" and must still be allocated, by the rules, to something on the ship.)

(4Z2) Firing Procedure: The mauler is a direct-fire weapon. It is fired by discharging energy into it (expending energy points) at the instant of firing in the Direct Fire Step. The amount of damage scored (there is no die roll) depends on the range and the amount of energy discharged.

At range 0-2, damage is twice the energy used.

At range 3-5, damage equals the energy used.

At range 6-10, damage is half of the energy used (drop fractions).

(4Z3) Other Rules: Maulers cannot damage plasma torpedoes or webs. Maulers cannot fire if the ship firing the mauler is using evasive maneuvers.

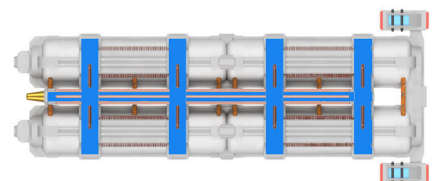

(424) Firing Arcs: Because the mauler is hard-welded to the ship (in the case of the Falcon, the ship is wrapped around the weapon), it fires only in a narrow arc directly ahead. Note the firing arc diagram (lower right corner) on the ship card. Only if the target is in one of these hexes (or the firing ship's hex) can it be struck by the mauler.

Because of the narrow firing arc, a mauler ship can use one of the two alternative arcs shown in the right diagram. If it uses the left one, it must mark the large "L" on the ship card to indicate that it is "tending left" and if it uses the right arc, it must mark the "R" to indicate it is "tending right". A ship that is "tending left" can only turn or sideslip left; it cannot turn or sideslip right (and vice versa). A ship can only turn or sideslip within the rules; however, a ship is never required to turn. A ship which is "tending" one direction or the other could, during the Direct Fire Step of any later impulse (even if it does not fire) change an "L" or "R" to "C" (center, straight ahead) or change "C" to "L" or "R". After any turn (or high energy turn) the ship can be reset to "C" (center, straight ahead) if the owner chooses.

(425) Mauler Power Systems: Mauler ships have huge banks of batteries so that they can discharge the weapon with tremendous power. Because of their nature, a mauler ship has two power tracks, one for generated power and one for battery power. These batteries can be used for other purposes, but no more than four points of battery power can be used by a mauler ship for non-mauler purposes during any given impulse.

WYN CLUSTER AUXILIARY HEAVY MAULER SQUADRON SCALE

COUNTER AXHM
POINT VALUE: 324
DAMAGE CONTROL: 6



POWER TRACK
+60
+50
+40
+30
+20
+10
9
8
7
6
5
4
3
2
1
0
+80
+70
+60
+50
+40
+30
+20
+10
9
8
7
6
5
4
3
2
1
0

Power when undamaged:
63 + 80 = 143.

WDS _____
Name _____

This ship has no probe launcher.

MARINES

| | | |
|----|--|--|
| 12 | | |
| 8 | | |
| 4 | | |

FRAME DAMAGE

| | | | | |
|---|--|--|--|--|
| 6 | | | | |
|---|--|--|--|--|

DRONES

| | | | | | | | | | | | |
|----|--|--|--|--|--|--|--|--|--|--|--|
| 1 | | | | | | | | | | | |
| 2 | | | | | | | | | | | |
| 3 | | | | | | | | | | | |
| 4 | | | | | | | | | | | |
| 5 | | | | | | | | | | | |
| 6 | | | | | | | | | | | |
| 7 | | | | | | | | | | | |
| 8 | | | | | | | | | | | |
| 9 | | | | | | | | | | | |
| 10 | | | | | | | | | | | |
| 11 | | | | | | | | | | | |
| 12 | | | | | | | | | | | |

WEAPONS USED

| | | | |
|---|---|---|---|
| 1 | 2 | 3 | 4 |
| 1 | 2 | 3 | 4 |
| S | T | U | V |
| W | X | Y | Z |

TURN MODE E
MOVE COST 1

BASE SPEED 8
TURN MODE 3
SPEED COST 8

BASE SPEED 16
TURN MODE 5
SPEED COST 16

BASE SPEED 24
NOT POSSIBLE FOR THIS SHIP

ACCELERATION COST 1

DECELERATION COST 1

HIGH ENERGY TURN BANNED

EVASIVE MANEUVER NOT ALLOWED

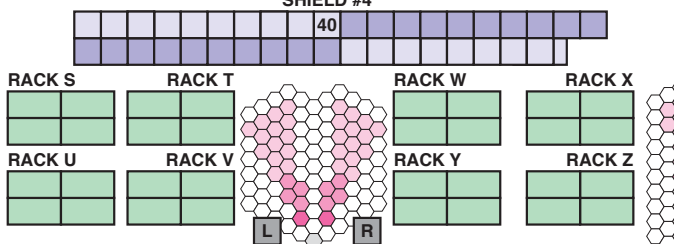
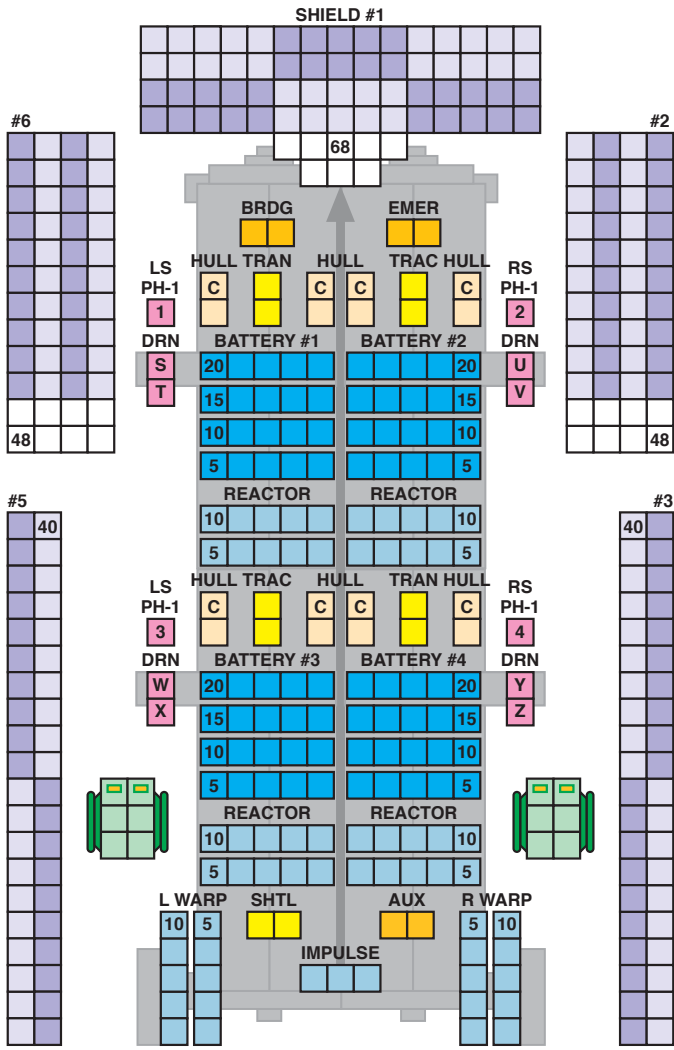

FEDERATION COMMANDER: APRIL FOOL'S 2018
SQUADRON SCALE SHIP CARD #AF04
Copyright © 2018 Amarillo Design Bureau, Inc.

FRACTIONAL POWER
0 1/4 1/2 3/4

STARMADA PLAYTEST RULE: A Mauler is treated as a single weapon mounted to fire into the "G" arc (60° directly ahead). The listed strength of the Mauler determines the number of damage points inflicted on the target when fired (no to-hit roll is necessary):

Range 1-2 hexes: Strength x4 Range 3-5 hexes: Strength x2 Range 6-10 hexes: Strength x1

For example, a Mauler with a listed strength of 4 would inflict 16 points of damage at a range of 1 or 2 hexes, 8 points at range 3 through 5, and 4 points at range 6 through 10. The Mauler's base strength is doubled if it was not fired in the previous Combat Phase. A Mauler's damage potential may be increased by using excess power. For every 10PP spent, the Mauler's strength is increased by +1.

STAR FLEET BATTLE FORCE

The four ships in this multi-game pack are represented by the cards below for *STAR FLEET BATTLE FORCE*.

Additional rules are required for the mauler. The mauler can fire four shots (cards) per turn. (When called upon, these represent the four battery banks on the SSD; all must fire at the same target.) As there are no “mauler” cards in the weapons deck, the mauler can fire any Photon Torpedo, Disruptor, or Plasma Torpedo card. (Wild Weasels do not affect maulers; electronic warfare cards do affect the mauler.) The mauler can fire front row to front row only. The mauler can use its battery packs defensively, playing one of the above weapons cards as “shield reinforcement”.

Comparison of SSDs to *SFBF* cards is not precise, but generally speaking two heavy weapons equal one heavy weapon icon, four phasers equate to one phaser icon, and one or two drone racks equate to one drone icon.

THOLIAN HEX BATTLESHIP
Crown of Tholia

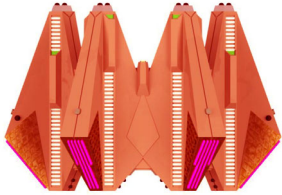

DISR DISR
DISR DISR

PH-3 PH-3 PH-1 PH-1 PH-1 PH-1 PH-3 WEB

24

KZINTI TRIMARAN CRUISER
Triple Threat

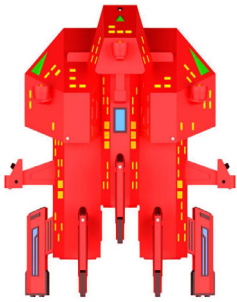

DISR DISR
PH-1 PH-1
DRN DRN
8
DRN DRN

WYN HEAVY AUXILIARY MAULER
No No Nannette

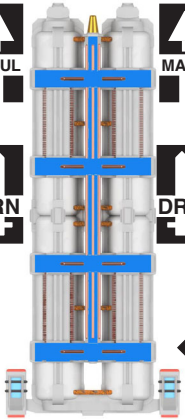

MAUL MAUL MAUL MAUL
DRN DRN DRN DRN
PH-1
12

Insert this card into the SHIP DECK.
When you draw this card, go get the
THOLIAN HEX BATTLESHIP
Crown of Tholia
Card and put it in your fleet.

GORN BUBBLE DREADNOUGHT
Five-Star

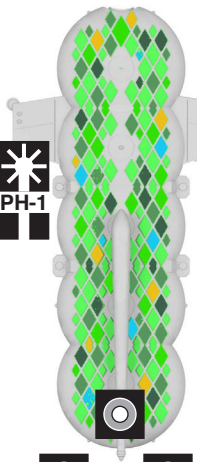

PL-R PL-S
PH-1 PH-1 PH-3 PH-1
PL-F
14

| | | | |
|---------------------------------------|-------------------------|--------------------------------------|-------------------------|
| | | | |
| | | | |
| CTB PW4 28 | BDN 14 | AxHM + 20 | TRI 10 |

FEDERATION COMMANDER: Counters for this game use true ship colors; the lettering is the original *SFB* monochrome for that empire. The icons are actual engineering graphics. The small box at the bottom right is so players can mark counters and combine multiple sheets. The emblem for each counter is on each counter.

STAR FLEET BATTLES: Counters for this game were originally monochrome (see *F&E*) but after *FC* was printed players wanted the true color engineering icons. As with *FC* there is a single-letter empire designator to avoid any confusion. Counters in both games include an individual unit identifier ("1" in this case).

FEDERATION & EMPIRE: Counters for this game have always used the mono-color scheme as players did not want to have to replace their entire inventory (which can exceed 10,000 pieces). There is no individual unit identifier as this is a strategic game. The number in the lower left is the combat strength. The plus sign means the WYN ship is a mauler; the P4 on the Tholian ship means it carries six gunboats and four fighter factors.

| | | | | | | | | | | | |
|---------------------------------------|-------------------------|--------------------------------------|-------------------------|---------------------------------------|-------------------------|--------------------------------------|-------------------------|--------------------------------------|------------------------|--------------------------|------------------------|
| | | | | | | | | | | | |
| | | | | | | | | | | | |
| CTB PW4 28 | BDN 14 | AxHM + 20 | TRI 10 | CTB PW4 28 | BDN 14 | AxHM + 20 | TRI 10 | CTB P2 14 | BDN 7 | AxHM 10 | TRI 5 |

These half-inch counters are what is actually in each game. Note that *F&E* counters are double-sided with the reverse showing the ship in crippled status, often losing some special marks.

| | |
|--|--|
| | |
| | |

GENERAL NOTES: Counters do not display a movement factor as this is controlled by the energy the ship has (in *SFB* and *FC*) or the rules (six hexes per turn for most units in *F&E*).

An effort is made to define each ship type by a three-letter identifier due to the limited space on the counters. This often causes confusion as a ship may have a longer formal designation. (The Klingon D5 in Romulan service is properly KD5R but is listed as KDR.) An effort is made to use the same identifier in each system but in a few cases *F&E* uses a different designation and lists both on the Ship Information Table.

The presence of an empire-identifying digit is not needed in *F&E* due to the monochrome counters. The letter is needed in *FC* and *SFB* because of confusion caused when mono-color icons were replaced by true colors. (Gorn ships were red in monochrome but gray in true colors; Kzinti ships were black in monochrome but red in true colors.) In all cases, the lettering remains the same as the original 1979 monochrome *SFB* counters; these colors are also reflected in certain elements of *FC* ship cards.

Sometimes the change to true colors made the ships hard to see (e.g., copper Tholians on red) but in these cases a white outline is added.

STARMADA and **A CALL TO ARMS: STAR FLEET** mostly use miniatures but either can borrow the counters from *SFB* or *FC*. In most cases, the ships available in those two games match specific *FC* products to facilitate this use. Counters are sold as spare parts.

Kzinti Triple Threat-class Battlecruiser

230 points (TRI)

This late-war experiment, which could have been built from badly damaged or incomplete War Destroyer and Frigate hulls, was to be the Kzinti answer to the multiple-hulled Lyran battlecruisers. Use of this ship requires permission of the opponent's girlfriend (or other bribable acquaintance nominated by the opponent).

Ships of the Class: *Triple Threat*

Turn: 6 Shields: 30
 Damage: 41 / 13 Marines: 16
 Craft: 4 shuttles
 Traits: Anti-Drone 2, Labs 6, Probe 2, Tractor Beam 4, Transporter 6, *Unique*
 Starline 2400: Shapeways.
 Starline 2500: Shapeways.

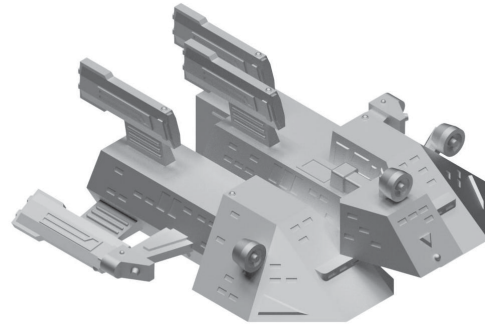

| Weapon | Range | Arc | AD | Special |
|-----------|-------|------|----|---|
| Phaser-1 | 18 | F | 1 | Accurate +2, Kill Zone 8, Precise |
| Phaser-1 | 18 | F, P | 1 | Accurate +2, Kill Zone 8, Precise |
| Phaser-1 | 18 | F, S | 1 | Accurate +2, Kill Zone 8, Precise |
| Phaser-1 | 18 | PH | 1 | Accurate +2, Kill Zone 8, Precise |
| Phaser-1 | 18 | SH | 1 | Accurate +2, Kill Zone 8, Precise |
| Phaser-1 | 18 | T | 4 | Accurate +2, Kill Zone 8, Precise |
| Disruptor | 24 | F | 1 | Accurate +1, Heavy, Kill Zone 16, Point-Blank 4 |
| Disruptor | 24 | F, P | 2 | Accurate +1, Heavy, Kill Zone 16, Point-Blank 4 |
| Disruptor | 24 | F, S | 2 | Accurate +1, Heavy, Kill Zone 16, Point-Blank 4 |
| Drone | 24 | T | 6 | Accurate +2, Devastating +1, Multi-Hit 6, Seeking (Drone) |

MAULER RULES FOR ACTA:SF

The Mauler Cannon was originally designed by the Romulans, but the technology was later sold to the Klingons and the Lyrans. The Mauler Cannon fires a coherent beam of intense, directional energy. Due to its massive energy requirements, mauler ships typically have multiple banks of batteries to feed power to the Mauler Cannon. Since the space for these batteries comes at the cost of other systems, these ships are unsuitable for any mission other than direct support of a targeted assault.

The Mauler Cannon is tied directly into the power systems of any ship it is installed on. This enables it to pour massive amounts of energy into the Mauler every time it fires. The mauler may be fired every turn, but it cannot be overloaded. The captain can decide how much power is dumped into the Mauler before firing. This can be as little as a single point or as much as every Joule of power the unit generates. Unlike most weapons, the damage output of the Mauler Cannon is dependent on the amount of energy used to power it when it does fire. This ability does come at a cost. The mauler is subject to multiple Power Drain penalties if fired at anything more than minimal power levels.

New Ship Trait: Mauler (X): A Mauler Cannon has three separate firing modes. It may be fired using no Power Drain penalty, one Power Drain penalty, or even two Power Drain penalties. The mode being used is declared at the time of firing. For each Power Drain penalty applied, double the AD of the Mauler Cannon.

Since the potential damage the mauler generates is tied into the operating power systems of the ship itself, ongoing damage from the battle will degrade the damage potential of the mauler. The Attack Dice of the weapon itself is reduced by 1 AD for every Xpoints of damage scored on the unit. (The "X" is different for every ship armed with a mauler.)

As the Mauler fires a single beam and only at the instant that the target is locked in the forward centerline targeting matrix, there is no "to hit" die roll and the weapon automatically hits.

New Weapon Trait: Damage Attenuation X/Y: Weapons with this trait fire a single beam that spreads out or dissipates as it travels towards the target. The Multi-hit value is reduced by X points for every Y-inches of range between the weapon and the target (Round values up to the nearest whole number, if necessary).

Fixed: Weapons with this trait are effectively built into the ship along the ship's forward/aft axis. As such, they can only fire along the center line of the ship [i.e. along the line delineating the port hemisphere / starboard hemisphere (PH/SH) firing arcs.]

Power Drain: Weapons with this trait require massive amounts of power to arm and fire. Any unit firing a weapon with this trait is subject to one of the Power Drain penalties shown on page 17 of the *ACTASFRulebook*, just as if using a Special Action.

Note: Units are still limited to a maximum of two Power Drain penalties per turn, regardless of the source (i.e., Scout Functions, Special Actions, or weapon traits).

No No Nannette-class Heavy Mauler

375 points (AxHM)

It is unclear if this ship was actually built, or if it was only a deception operation intended to terrify any possible invaders. Based on a heavy freighter like the WYN dreadnought *Nancy*, the four pods were packed with power systems and a mauler weapon was added above the ship's centerline. Any enemy ship which appeared in its firing arc would be doomed. Use of this ship requires permission of the opponent's girlfriend (or other bribable acquaintance nominated by the opponent).

This unit cannot use either the High Energy Turn! or the Take Evasive Action! special action.

Ships of the Class: *No No Nannette*

Turn: 5

Shields: 48

Damage: 65 / 21

Marines: 12

Craft: 2 shuttles

Traits: *Probe 0*, Labs 1, Mauler (10), Slow, Tractor Beam 4, Transporter 4, *Unique*

Starline 2425: Shapeways

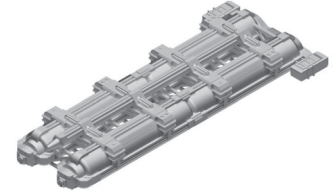

| Weapon | Range | Arc | AD | Special |
|----------|-------|-------|----|--|
| Phaser-1 | 18 | PH | 2 | Accurate +2, Kill Zone 8, Precise |
| Phaser-1 | 18 | SH | 2 | Accurate +2, Kill Zone 8, Precise |
| Mauler | 12 | Fixed | 6 | Damage Attenuation 1/4, Fixed, Heavy, Mauler (10), Multi-Hit 4 |
| Drone | 24 | T | 4 | Accurate +2, Devastating +1, Multi-Hit 6, Seeking (Drone) |
| Drone | 24 | T | 4 | Accurate +2, Devastating +1, Multi-Hit 6, Seeking (Drone) |

Crown of Tholia-class Battleship

525 points (CTB)

A design study to produce a battleship by welding together three heavy cruisers, the Hexagon Battleship *Crown of Tholia* was never built because the loss of three heavy cruisers (and two destroyers to provide the six engines) would have been excessive. A Mockup was built to lure enemy spies into a trap. Use of this ship requires permission of the opponent's girlfriend (or other bribable acquaintance nominated by the opponent).

Ships of the Class: *Crown of Tholia*

Turn: 5

Shields: 45

Damage: 84 / 28

Marines: 24

Craft: 12 shuttles (When fighter rules are published, ship has 4 shuttles and 8 fighters.)

Traits: Command +1, Labs 12, Probe 1, Quick Launch (*3, ship has three shuttle bays), Tractor Beam 6, Transporter 11, *Unique*, Web

Starline 2400: Shapeways

Starline 2500: Shapeways

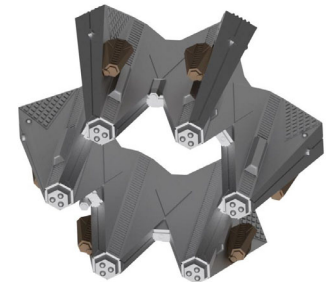

| Weapon | Range | Arc | AD | Special |
|------------|-------|----------|----|---|
| Phaser-1 | 18 | F, P | 9 | Accurate +2, Kill Zone 8, Precise |
| Phaser-1 | 18 | F, S | 9 | Accurate +2, Kill Zone 8, Precise |
| Phaser-1 | 18 | A | 4 | Accurate +2, Kill Zone 8, Precise |
| Phaser-3 | 6 | A, P, SI | 12 | Accurate +1, Kill Zone 2, Precise |
| Disruptor | 24 | F | 6 | Accurate +1, Heavy, Kill Zone 16, Point-Blank 4 |
| Disruptor | 24 | F, P | 3 | Accurate +1, Heavy, Kill Zone 16, Point-Blank 4 |
| Disruptor | 24 | F, S | 3 | Accurate +1, Heavy, Kill Zone 16, Point-Blank 4 |
| Web Caster | 18 | F | 1 | |
| Web Caster | 18 | F | 1 | |
| Web Caster | 18 | F | 1 | |
| Web | | PH | | |
| Web | | SH | | |

Pentaceratops-class Dreadnought

330 points (BDN)

A design intended for quick construction, once plans were complete it was found to be no faster or cheaper to build than a standard dreadnought and the project was dropped. Use of this ship requires permission of the opponent's girlfriend (or other bribable acquaintance nominated by the opponent).

Ships of the Class: *Five Star, Penticon.*

Turn: 5 Shields: 36
 Damage: 52 / 17 Marines: 30
 Craft: 4 shuttles
 Traits: Command +1, Labs 6, Probe 1, Quick Launch (*4), Tractor Beam 3, Transporter 4
 Starline 2400: Shapeways.
 Starline 2500: Shapeways

| Weapon | Range | Arc | AD | Special |
|------------------|-------|------|----|---|
| Phaser-1 | 18 | F, P | 1 | Accurate +2, Kill Zone 8, Precise |
| Phaser-1 | 18 | F, S | 1 | Accurate +2, Kill Zone 8, Precise |
| Phaser-1 | 18 | PH | 2 | Accurate +2, Kill Zone 8, Precise |
| Phaser-1 | 18 | SH | 2 | Accurate +2, Kill Zone 8, Precise |
| Phaser-1 | 18 | P | 1 | Accurate +2, Kill Zone 8, Precise |
| Phaser-1 | 18 | S | 1 | Accurate +2, Kill Zone 8, Precise |
| Phaser-1 | 18 | T | 4 | Accurate +2, Kill Zone 8, Precise |
| Phaser-1 | 18 | A, P | 1 | Accurate +2, Kill Zone 8, Precise |
| Phaser-1 | 18 | A, S | 1 | Accurate +2, Kill Zone 8, Precise |
| Phaser-1 | 18 | T | 4 | Accurate +2, Kill Zone 8, Precise |
| Phaser-3 | 6 | PH | 1 | Accurate +1, Kill Zone 2, Precise |
| Phaser-3 | 6 | SH | 1 | Accurate +1, Kill Zone 2, Precise |
| Plasma-F Torpedo | 12 | PH | 2 | Accurate +3, Devastating +1, Energy Bleed, Heavy, Multi-Hit 4, Reload, Seeking (Plasma), Small Target |
| Plasma-F Torpedo | 12 | SH | 2 | Accurate +3, Devastating +1, Energy Bleed, Heavy, Multi-Hit 4, Reload, Seeking (Plasma), Small Target |
| Plasma-S Torpedo | 24 | F, P | 4 | Accurate +3, Devastating +1, Energy Bleed, Heavy, Multi-Hit 4, Reload, Seeking (Plasma), Small Target |
| Plasma-S Torpedo | 24 | F, S | 4 | Accurate +3, Devastating +1, Energy Bleed, Heavy, Multi-Hit 4, Reload, Seeking (Plasma), Small Target |
| Plasma-R Torpedo | 24 | F | 7 | Accurate +3, Devastating +1, Energy Bleed, Heavy, Multi-Hit 4, Reload, Seeking (Plasma), Small Target |

Quick Launch *4:

Note: Due to the nature of its construction, this unit has 4 separate shuttle bays. It can launch / recover up to 4 shuttlecraft per turn.

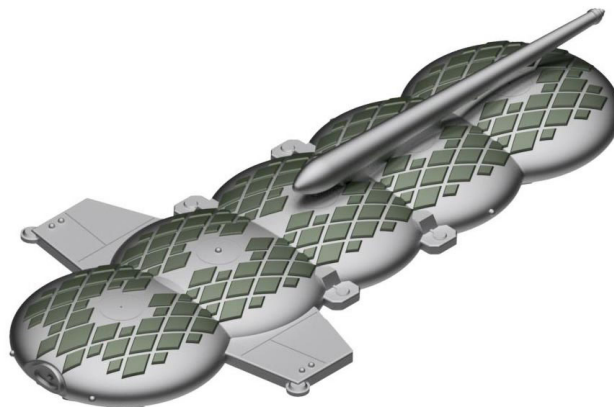

NAME:

Kzinti Trimarane Cruiser

275

↑ 11 10 9 8 7 6 5 4 → 9 8 7 6 5 4 3 2
 F 3 2 1 S 1
 ← 9 8 7 6 5 4 3 2 ↓ 7 6 5 4 3 2 1
 P 1 A
 HULL 12 11 10 9 8 7 6 5 4 3 2 1
 ENG 5 5 4 3 2 1 WPN 20 17 14 10 7 4

Phaser-1 3-6-9 1x3+/1/1 Dfn
 FAL FAR FA LS RS (3)
 Phaser-3 1-2-3 1x3+/1/1 Dfn
 360° (2)
 Disruptor 5-10-15 1x4+/1/1
 - Overload 5-10-* 1x4+/1/2 2PP; Crn
 FA (1)
 Drone Rack MA 6 1x2+/1/3 Exp
 (3)
 Anti-Drone Tractor Beam (2)
 Engine Power Ratio (4); Science (3); Wide Turn

Marines 5 4 3 2 1 Shuttlecraft 4 3 2 1
 MOVEMENT ORDERS NOTES
 1
 2
 3
 4
 5
 6
 7
 8
 9



NAME:

Gorn Bubble Dreadnought

395

↑ 15 14 13 12 11 10 9 8 → 10 9 8 7 6 5 4 3
 F 7 6 5 4 3 2 1 S 2 1
 ← 10 9 8 7 6 5 4 3 ↓ 10 9 8 7 6 5 4 3
 P 2 1 A 2 1
 HULL 14 13 12 11 10 9 8 7 6 5 4 3 2 1
 ENG 6 6 5 4 3 2 1 WPN 23 20 17 14 10 7 4

Phaser-1 3-6-9 1x3+/1/1 Dfn
 360° FAL FAR LS RS RH (7)
 Phaser-3 1-2-3 1x3+/1/1 Dfn
 LS RS (1)
 Plasma-R Torpedo MA 8 3x2+/1/4 3PP; Evp; Slw; Slw
 - Bolt 5-10-15 1x4+/1/4 3PP; Dfs; Slw; Slw
 FAL (1)
 Plasma-S Torpedo MA 8 3x2+/1/3 2PP; Evp; Slw; Slw
 - Bolt 5-10-15 1x4+/1/3 2PP; Dfs; Slw; Slw
 LP RP (1)
 Plasma-F Torpedo MA 8 2x2+/1/3 2PP; Evp; Slw; Slw
 - Bolt 5-10-15 1x4+/1/1 2PP; Dfs; Slw; Slw
 LS RS (1)
 Tractor Beam (1)
 Engine Power Ratio (6); Science (3); Wide Turn

Shuttlecraft 4 3 2 1
 Marines 10 9 8 7 6 5 4 3 2 1
 MOVEMENT ORDERS NOTES
 1
 2
 3
 4
 5
 6
 7
 8
 9

