

STAR FLEET BATTLES



SUPPORT SHIPS



RULEBOOK

**CAPTAIN'S
MODULE R11**



STAR FLEET BATTLES

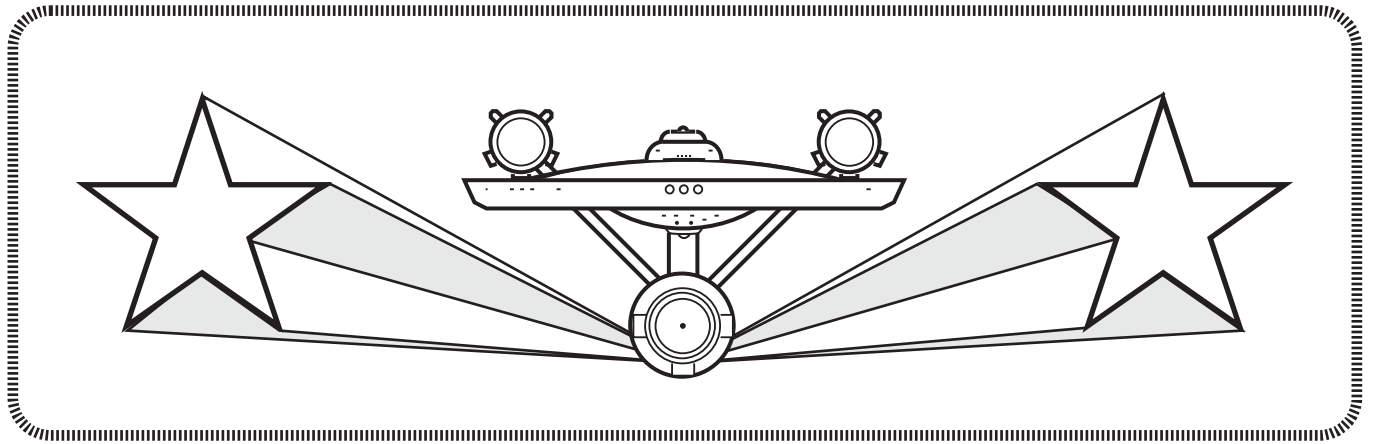

CAPTAIN'S MODULE

★ R11 ★ SUPPORT SHIPS

TABLE OF CONTENTS

INTRODUCTION

DESIGNER'S NOTES	2
PUBLISHER'S INFORMATION	2

SHIP DESCRIPTIONS

R1 GENERAL UNITS	3
R2 FEDERATION.....	13
R3 KLINGON EMPIRE.....	17
R4 ROMULAN EMPIRE.....	19
R5 KZINTI HEGEMONY	21
R6 CONFEDERATION OF THE GORN.....	23
R7 THOLIAN HOLDFAST.....	25
R8 ORION PIRATES	27
R9 HYDRAN KINGDOM	29
R10 ANDROMEDAN INVADERS.....	31
R11 LYRAN EMPIRE	33
R12 WYN CLUSTER.....	35
R13 INTER-STELLAR CONCORDIUM.....	37
R14 LYRAN DEMOCRATIC REPUBLIC.....	39
R15 SELTORIAN TRIBUNAL.....	41
R16 JINDARIAN CARAVANS.....	42
R17 THE VUDAR ENCLAVE	43

GENERAL SCENARIOS

SG85 FALSE ECONOMICS.....	45
---------------------------	----

HISTORICAL SCENARIOS

SH240 AN URGENT MATTER.....	47
SH241 <i>JUST CAUSE</i>	49
SH242 GAMBLE	51
SH243 BUSTING THE HANDOFF.....	52
SH244 CONVOY TERROR.....	53

PERSPECTIVES

PATROL TENDERS.....	16
THEATER TRANSPORTS	26
CIVILIAN MISSION SHIPS.....	36
DIVISION CONTROL SHIPS.....	39
SCOUT PODS.....	39
FAST RAIDERS	42
WORKBOATS	43

DATA ANNEXES

ANNEXES	55
MASTER SHIP CHART	57

**(Z38.0) NOTES ON
MODULE R11 SUPPORT SHIPS**

(Z38.1) ORGANIZATION AND COMPONENTS

STAR FLEET BATTLES MODULE R11 is a modular expansion of the *SFB* game system. You will need the **SFB Basic Set** to use this material, and other products (e.g., **Advanced Missions, C1, C2, C3, K**) to use it to the fullest extent. **Module R11** includes this 64-page rulebook, 108 counters, and an 96-page SSD book. **JULY 2007 PRINTING.**

(Z38.2) DESIGN CREDITS

SFB Designer.....Stephen V. Cole, PE
 Module R11 Designer.....Steven P. Petrick, IN
 Proofreading.....Jean Sexton
 Chief of ADB Security.....Ramses
 ADB Inspector General.....Isis
 Cover Artist.....Adam Turner
 Playtesters and proofreaders.....Robert Cole, John Sickels, Scott Tenhoff, Frank Brooks, Richard Sherman, John Crawford.

(Z38.3) PUBLISHER'S INFORMATION

This product is published by:
 AMARILLO DESIGN BUREAU, INC.
 POST OFFICE BOX 8759
 AMARILLO, TEXAS 79114-8759
 Telephone: 806-351-1950 (Fax: 806-351-2585)
 Email: Design@StarFleetGames.com
 Website: www.StarFleetGames.com

Include a stamped self-addressed envelope with all rules questions, submissions, or other inquiries. Most of the information which players seek (e.g., product schedules) is available free on our website.

All submissions are accepted only under our standard terms as published in **SFB Advanced Missions**. In summary, any submission becomes our property on receipt and may be modified at our sole discretion before publication. The author of a submission receives authorship credit and compensation at our standard rates.

ADB, Inc., products are available to individuals in retail stores, from several direct-mail outlets, from the shopping cart on our website, and directly from us. If your store does not carry our products, send us the store name and address and we will have our wholesalers contact the manager.

(Z38.4) DESIGNER'S INFORMATION

This product began many years ago as "the next thing after *Module R9*." (We all recall that *R10* came before *R8*. Don't try to figure out why if you don't already know.) As *R9* was finished, we defined *R11 Support Ships*, *R12 Unique Ships*, and *R13 More Ships That Never Were*. As of July 2007, no plans for *Module R14* have been seen.

As with any of the R-modules since *Module R5*, we set out to find some entire classes which could be used to anchor the product. Previous modules were built around five or six such classes, and *Module R11* has five.

Division control ships were a late-war development to maximize deployment of attrition units. The began back when we added area control ships in *Module J2*, as there were competing theories over whether to fit those ships with heavy

fighters or PFs. A few of these had been seen in *Captain's Log* as a preview.

Theater transports provided an "express" delivery system to supplement the convoys that brought most supplies, as well as a means of moving pods around. Critical for campaign games, they are a valuable addition to the fleet.

Fast war cruisers were one of two "new types" selected (from several alternatives) fairly late in the process. These have a valuable role in pursuit and reserves, and can undertake dangerous raids by working in pairs.

Light gunboat tenders were another of the "late in the process" additions. They provide a valuable insight into the history of PFs, being one of the earliest forms of PFT, and they remained in use beyond the end of the General War.

Workboats began as an off-hand comment in a RPG product. Various players of our role-playing games had noted that the "gunboats" (PFs) would make dandy little "adventure ships" if they had fewer weapons, a smaller crew, and better accommodations. We created the Klingon U1 for this purpose, and it actually made sense.

Freighter skids became a tiny (one page) segment of this product that spawned over a hundred plausible civilian mission ships, for everything from exploration to mining, from local defense to rescue, from transport to emergency relief.

Lots more ships were added to the product. Some of these were "missing" ships (Gorn local defense scout, ISC system defense ships, construction docks, small fast freighters). Many were generated by *F&E* (scout pods, heavy fighter resupply pods, PF transport pods; Federation CAV, NVH, POV; Lyran NTG, NSC, NCV). Others had been published in *Captain's Log* (Federation Express escorts, prime corvette, free escort carrier, Tholian DDV and DDS, Hydran Pegasus-R, auxiliary scouts, armed cutter) and deserved to be in a product. Still more were added from player suggestions and requests (ISC blockade runner, Andromedan Recon Cobra, light monitors), and many others.

Blank pages are always a curse of R-modules. Players hate it when we sell them a whole sheet of paper containing two paragraphs of rules, and hate it even more when we combine ships from several races on the same page. The solution was to give each race its own sheet of paper and fill the blank pages with art, essays, and other things.

This product is dedicated to **The Logisticians** of all armies, fleets, times, and nations, who carry victory on their backs, without glory and, all too often, without thanks.

(Z38.5) COPYRIGHT & LICENSING

STAR FLEET BATTLES — CAPTAIN'S EDITION — MODULE R11 — SUPPORT SHIPS and all contents thereof are copyright © 2007 by ADB, Inc. All rights are reserved under the Pan-American, Berne, and International Copyright Conventions.

No material which is based on, for use with, incorporates elements of, or is derived from **Federation Commander, Star Fleet Battles, Federation & Empire, Star Fleet Missions, Star Fleet Battle Force, Prime Directive**, or the **Star Fleet Universe** background can be published by any party without the advanced written permission of ADB, Inc.

SFB is produced under license from Franz Joseph Designs, authors of the STAR FLEET TECHNICAL MANUAL.

Elements of the Star Fleet Universe are the property of Paramount Pictures Corporation and are used with their permission.

(R1.0) GENERAL UNITS**(R1.68) SKIDS**

(R1.68) FREIGHTER SKIDS: A significant upgrade to freighters were the so-called “skids” that appeared in or before Y140 and became far more prevalent in passing decades; by Y165 about 10% of freighters had a skid of one type or another. These were cylinders that were the standard 40 meters in diameter but which were only three-to-ten meters long. Skids fastened to the front of the standard cargo pod (or any pod), providing the ship with additional volume and systems. These turned freighters into much more capable ships. Various skids existed including types with passenger accommodations, transporters for rapid cargo handling, shuttle bays for landing cargo on planets where transporters were impractical, weapons for self-defense, and other systems. Some prosperous captains had skids that contained more comfortable accommodations for their crews, and some entire families lived their entire lives in such skids. Using a skid does not increase the movement or life support cost of the freighter. A small freighter could, at least in theory, operate with only a skid (or with up to three of them and no pod). The concept of skids actually grew out of the earlier and similar components that were used (along with freighter drive and control modules) to create the tiny “harbor tugs” and “salvage tugs”.

Most skids were not used by common freighters on normal cargo runs, but by government-owned or chartered ships on special missions. (Players should think of using these skids to build special ships for civilian missions, not to bulk up their convoys against pirates.)

Hundreds of colonial systems (a colony with at least 5,000 people who had begun to establish mining outposts on other worlds of their star system) bought an old freighter that was no longer reliable enough to travel safely between stars and used it to support their local operations. Some operated without cargo pods and only one or two skids while others used a cargo pod (often, one of the shorter ones) along with a skid or two. Commercial and government ventures other than cargo hauling often rented or purchased a freighter and used a skid or two to customize its capabilities.

Skids cannot be used by most naval auxiliaries (carriers, PFTs, scouts, space control ships, suicide freighters, repair ships, minelayers, Q-ships, web tenders, and auxiliary cruisers, including WYN auxiliaries) as these already have the maximum amount of weight and power the frame can handle, and the designs have to be hard welded in any case. Skids were often added to hospital ships, exploration ships, tramp steamers, passenger liners, prospecting ships, armed freighters, and troop ships for special missions. Harbor tugs and salvage tugs could not use skids due to the nature of their hard-welded construction, but it was possible to create a similar effect by combining a tug skid, a pod-less freighter, and other skids.

A standard small freighter could operate with a pod and one skid; a large freighter could operate with two pods and two skids; a heavy freighter could operate with four pods and two skids. A small freighter could operate with up to three skids if it had no pod, and a large freighter or huge freighter could operate with up to six if they had no pods (a huge freighter cannot operate with two pods and six skids). It was possible to create a tailor-made ship for any of a variety of missions in this way. Large and heavy freighters cannot operate with a cargo pod on one side and three skids on the other side. In the descriptions of the skids below, the

freighters are assumed to have their normal cargo or other pods as specified above.

All of the skids listed below, except the first two which were in *Module R8*, are in *Module R11*. No counter is used as they are considered to be part of the freighter to which they are attached.

(R1.68A) THE GENERAL SKID (GS): The General Skid was used by freighters that were going into areas of some hazard where they would be more reliant on their own resources.

(R1.68B) THE LIGHTER ABOARD SKID (LASH): The LASH Skid was used by freighters that would visit colony planets not developed enough to afford a commercial platform, or even to maintain their own supply of HTS shuttles to move goods to or from the planet’s surface.

(R1.68C) POLICE/SECURITY SKID: A colony could use a skid of this type, together with the chassis of an old freighter, to produce a “customs and local security” ship. This gave the colony a “spaceship capability” to inspect freighters and enforce the assignment of mining claims. Some systems used skiffs for this purpose, and it was mostly a matter of buying what was available once a colony decided it needed to own an armed spacecraft.

In some systems, the police skid would be used with a cargo pod, and the colony would slowly send export items up to the cargo pod (which might otherwise be left adrift in orbit) and then the pod would be swapped for one from an arriving freighter, and unloaded (and refilled) over a period of time.

(R1.68D) CONVOY COMMAND SKID: A senior freighter captain (or a military officer) and his staff would control a large convoy from this skid. Skids of this type were owned by governments for use in time of war when large convoys would be necessary, although a few were held by large shipping corporations. When the convoy was formed, the skid would be added to a freighter chosen as the flagship. In some cases, a large freighter might be chosen as it could carry two skids: the convoy command skid and perhaps one of the armed skids. This skid has the effect of increasing the command rating of the escorts by three levels to a maximum of 6. This means that if the skid is added to a freighter and Federation police cutters (command rating of 3) are assigned as escorts, the cutters would have an assumed command rating of 6, allowing seven such cutters to act as the escorts for the convoy. If the escort included a police flagship (command rating of 4), the maximum command rating would still be six as the skid cannot increase the command rating beyond 6. If an NCL is part of the escort (command rating of 6), there would be no increase in its command rating.

(R1.68E) LIFE SUPPORT SKID: Most freighters carried cargo, not passengers. While there was physical room in a pod for hundreds of passengers, a small freighter lacked the ability to provide air or water for them. A life support skid was designed to do this, allowing any cargo pod to be used as a low-class people mover. Accommodations on such a ship could range from nothing (people slept and sat on the bare decks) to cheap hotel standards (whatever old furniture the ship’s owners could find).

This skid was often used in combination with science or other skids on non-cargo extended missions.

(R1.68F) CARGO SKID: This skid provided a small cargo carrying capacity. Rarely used just to increase the cargo volume of a standard freighter, it was more commonly used for special cargo that required a unique environment, or on pod-less freighters used for other missions. It could, for

example, be combined with a science skid and an accommodation skid to produce a ship capable of extended survey missions.

(R1.68G) POWER SKID: Providing increased power, this skid was virtually never used by a standard freighter (which had nothing to use the extra power). It was, instead, designed to provide power for other skid types that needed it.

(R1.68H) SHUTTLE SKID: This skid provided a large shuttle bay with a single hatch that could handle size-1 or size-2 shuttles. The bay could operate four size-1 shuttles, or two size-2 shuttles, or two size-1 shuttles and one size-2 shuttle. (Shuttles are not included in the BPV of this skid and must be purchased separately as part of the battle force.) It was often used without shuttles by freighters whose run included planets that owned their own shuttles for purposes of lifting cargo out of the planet's gravity well, and thus would often not have any shuttles aboard during transit. Contrary to an amusing trivideo series (*Terry and the Pirates*), this skid was never used to carry fighters. Freighters could not afford fighters (and certainly could not afford the cost of the pilots and mechanics) and the skid has no ability to maintain them.

(R1.68I) SEARCH AND RESCUE SKID: Most colonial system governments eventually obtained one of these SAR (Search and Rescue) skids. Sometimes it was combined with a police skid (and sometimes an additional skid) on a pod-less freighter to produce a "space guard" ship (very common in systems with dozens of mining stations and plenty of money), but most SAR skids were kept in storage to avoid the cost of continuous operations. The Federation Police Service kept several pod-less freighters in storage (one per province) with a combination of SAR, medical, and other skids for emergency operations.

(R1.68J) SALVAGE SKID: This skid was rarely seen during times of peace, simply because no colonial system had enough use for one. During times of war, it would appear on independent freighters looking to make a quick buck by scavenging the battlefields. Sadly, more than one such small freighter ran afoul of the hazards of such battlefields. Larger freighters sometimes operated two such skids.

(R1.68K) MEDICAL SKID: Skids of this type were maintained mostly by governments. Some were stored so they could be quickly added to any available freighter, while a few were kept as part of pod-less freighters (combined with SAR and other skids) as regional emergency ships. Wealthier colonial systems (with mining stations on a hundred moons and asteroids) might have a skid of this type in storage for emergencies, such as an outbreak of some disease, natural disaster, or engineering catastrophe. This could be used to minimize the risk of further contagion by keeping the medical personnel and patients isolated. In any case, the medical personnel were not kept on board waiting for an emergency, but were borrowed from local hospitals when needed.

(R1.68L) REPAIR SKID: This skid provided a minimal amount of repair capability, and was sometimes combined in pod-less "space guard" type ships. Only wealthier systems purchased such skids, which (ironically) had to be kept in use to be useful, as the highly skilled workforce could not be quickly recruited from other duties. These systems either had enough local shipping, or enough transit traffic, to justify the expense. (National governments simply used the much more capable repair freighters.)

A repair skid was almost never seen as part of a convoy as the ship being repaired had to stop and dock to the ship

with the repair skid, something impossible in combat zones. (It was never seen on an independent freighter, which could not afford something for which it had no use.) Repair skids were often combined with tug skids and SAR skids on pod-less freighters.

(R1.68M) CONSTRUCTION SKID: Often found on freighters transporting small ground bases or other elements of a colony. The skid's function was to assist in the establishment of small bases. Wealthier colonial systems might own such a skid (usually combined with a cargo pod) to help construct mining stations on airless or otherwise uninhabitable bodies in their system.

(R1.68N) RECOVERY SKID: This skid included power (to allow any freighter with a tractor beam to tow something), a minimal amount of repair capability (to prepare a disabled ship for towing), and quarters for the technicians needed. It was usually stored in a middle-class colonial system and fitted to any available freighter for an improvised recovery capability.

The recovery skid was an alternative to a repair skid, and while less capable, could be quickly brought out of storage and into use, needing only a few repair technicians. Note that a small freighter would have to be fitted with a ducktail or it would not have a tractor beam to tow the disabled ship.

(R1.68O) FACTORY SKID: Freighters of both the small and large varieties would use this skid. It was designed to allow independent freighters to respond to market forces by manufacturing small items on board while traveling between star systems. It could not produce major end items (such as shuttlecraft), but could produce durable goods and had a minimal ability to process small quantities of raw ore. Most could handle minor casting of metal parts and could easily cast plastics and similar materials.

In wartime, a few such skids were produced by governments with far more expensive and capable systems. The Kzintis and Klingons both operated such ships to produce drones to support forward fleet elements, but the vulnerable and expensive ships had to be kept so far back from the front that any benefit was negligible.

(R1.68P) MINING SKID: Often found paired with an accommodation skid on larger freighters intended to explore an asteroid field. The skid allowed a freighter to process small amounts of ore into ingots, but it would take such a facility an inordinately long time to fill a cargo pod. It was more commonly operated by local miners who bought an old worn-out freighter chassis to operate from, and used it with an accommodation skid and a cargo skid.

(R1.68Q) PRODUCTION SKID: Similar to the factory skid, the production skid was actually an animal or vegetable processing plant producing foodstuffs and "animal products" from the local environment, or perhaps reducing those products to nutrients useable by the crops of the local colony. Processed animal (including fish) or vegetable matter was more easily stored for shipment to other colonies (or for sale to asteroid miners). This skid was very rare as there was not much call for it, but some freighters operated on routes where this skid was highly useful, and in wartime such skids were used to provide a local source for food for deployed fleet units.

(R1.68R) SCIENCE SKID: Never found on a standard freighter (which could not afford to pay the scientists, and had no reason to study anything), this skid was used only on ships

chartered to explore or survey various systems. Most were operated by universities and governments.

(R1.68S) ACCOMMODATION SKID: This skid was designed to allow a freighter to carry a few passengers, and was more commonly used on chartered non-cargo missions such as asteroid mining or planetary surveying. Accommodations were crowded if a full load of passengers was present, and the skid was originally designed to have no direct access to anyplace else on the freighter. (This was primarily a safety matter, but did avoid having the passengers try to take over the ship.) The skid provides one militia squad if the skid itself is boarded, but that militia unit cannot leave the ship. Special scenario rules might define that some of the passenger crew units are inherently boarding parties, but they are otherwise simply civilians.

(R1.68T) SELF-DEFENSE SKID TYPE-I: The most powerful of the self-defense skids, this skid had phaser-2s and drones, and was used by the Klingons, Lyrans, Kzintis, and Federation. The type-I self-defense skid does not improve the freighter's seeking weapon control abilities. Even a large freighter with two of these skids can still only control three seeking weapons at one time. Drones are always General Availability types. (Special scenario rules may define other drone types representing a government charter or some other special condition.) A plasma-D version appeared in Y166 (used by the Gorns, Romulans, and ISC). If a large freighter operated two skids of the plasma-D version, two of the racks will have an LS launching arc and two will have an RS launching arc. Governments preferred armed freighters, and independent commercial freighters could hardly hope to afford one. It was used mostly by corporations that could afford to equip a few of their ships for higher-risk areas.

(R1.68U) SELF-DEFENSE SKID TYPE-II: A more common self-defense skid, and actually the first version to appear, it was armed only with phaser-2s. It was used by all races in the Alpha Quadrant, and remained in use after the type-I self-defense skid appeared if only because it was cheaper to operate (not needing military technicians to care for the finicky drones). It was commonly used by corporations that could get cheaper insurance rates if ten percent of their ships had such a skid. Independent freighters might aspire to buy one, but could only afford it by accepting higher risk missions.

(R1.68V) SELF-DEFENSE SKID TYPE-III: Easily the cheapest of the self-defense skids, but (surprisingly) not the most common. While it tripled a small freighter's firepower, even this was not sufficient to drive off a pirate. It was sometimes used by commercial freighters (those which could afford it), and was in fact designed and marketed as part of a "skid stack" on a pod-less freighter chartered for some non-cargo mission.

(R1.68W) FIGHTER SKID: This skid was used by small colonies to try to increase the effectiveness of their defending fighters. The skid does not include deck crews or fighters, and fighter supplies (to include extra deck crews) cannot be purchased for it under Commander's Options. A freighter with this skid cannot lend electronic warfare to the fighters, gains no benefits in controlling seeking weapons, and cannot operate remotely-controlled fighters (J15.0). (The fighters that launch from it could be remotely-controlled from the planet.) Before a scenario begins, the player owning a fighter ground base and operating a freighter with this skid can assign a portion of the ground base's fighter stores (including any purchased with the base's Commander's Option Items) to the skid (or skids if a large freighter is used). Two deck crews

must be assigned to each fighter skid. These deck crews can be the two extra bought with the base's Commander's Options, or subtracted from the base's existing deck crews. The two deck crews (and one crew unit) included on the skid's SSD are there to reflect such assignment and are not in addition to it.

At WS-0 or -I the two fighters the ground base is allowed to have ready to launch can be stationed aboard the freighter in its fighter skid. (In the case of a large freighter with two skids, up to four fighters can be on the skids, but only two can be ready for launch.)

At WS-II the two fighters that are launched on patrol are assumed to have come from the freighter (that was why you had the fighter skid).

At WS-III two of the four fighters allowed to be launched are assumed to have come from the freighter (if it is a large freighter with two skids, all four of the launched fighters came from these skids).

This skid is dependent on the fighter ground base for its operations. Therefore freighters with this skid cannot carry fighters when the freighter is part of a convoy or sent on an independent foray.

If a freighter operating this skid is part of a convoy, it can operate normal admin or HTS shuttles as any other shuttle bay, but will not have any fighters or supplies for fighters (delete the deck crews and one crew unit). The skid cannot be used to launch scatter packs, unless shuttles are present and the freighter has a source of drones, e.g., has a self-defense skid type-I in addition to the fighter skid. The skid cannot be used as a base for fighters from an auxiliary or other carrier, but could repair such fighters under the normal rules for shuttle repair using the freighter's normal deck crews (J4.814). It could even load drones (assuming it has some as noted above) onto the rails of such a fighter using the (J4.8962). Note, this skid does not include any shuttles in its BPV, and any shuttles for it must be purchased as part of the force.

(R1.68X) WORKBOAT SKID: With the advent of cheap (relatively speaking) workboats, a skid was developed to allow freighters to operate them. The small crews of the workboats compared to PFs made this skid feasible. A PF could dock to this skid, but could not be rearmed or have its warp packs replaced. Skiffs (R1.52) cannot be carried by this skid, or indeed on any mech link. A freighter with this skid can be equipped with workboats (R1.PF7) purchased as part of the battle force as casual PFs, but not any other kind of PF.

(R1.68Y) GUNBOAT SKID: A very rare skid used only by governments, if only because of the great expense of operating a true PF compared to a workboat. The skid includes no PF supplies in its BPV. Players wishing to base a PF (or PFs) from this skid must purchase all such supplies (drones, spare warp packs, etc.) as part of their battle force.

(R1.69) DUCKTAILS

(R1.69) FREIGHTER DUCKTAILS: Another innovation was the "ducktail" drive module. The earliest date of these drive units is not known, but there are references dating from Y140 that indicate they were hardly new at that time. Ducktails do not increase the movement or life support cost of the ship.

Ducktails cannot be used by most naval auxiliaries (carriers, PFTs, scouts, space control ships, suicide freighters, repair ships, minelayers, Q-ships, web tenders, and auxiliary cruisers, including WYN auxiliaries) as these already have the maximum amount of weight and power the frame can handle, and the designs have to be hard-welded in any case. Ducktails were often added to hospital ships,

exploration ships, tramp steamers, passenger liners, prospecting ships, armed freighters, and troop ships for special missions. Harbor tugs and salvage tugs could not use ducktails due to the nature of their hard-welded construction.

All of the ducktails listed below, except (R1.69A) and (R1.69B) which appeared in *Module R8*, are in *Module R11*; no counter is used as they are considered to be part of the freighter to which they are attached.

(R1.69A) FREIGHTER DUCKTAILS (S-DT): This was a standard small freighter drive module enlarged to include a tractor beam and a heavy transport shuttle. The tractor beam allowed not only more efficient docking but allowed ships in a convoy to help each other if one broke down, not to mention another option for drone defense. The heavy transport shuttle allowed for an increase in efficiency in bringing cargoes up from, or down to, a planet's surface. This allowed a small freighter to compete with a Free Trader for the trade from an otherwise undeveloped colony. While the Free Trader's ability to land gave it one edge, the volume of cargo that a small freighter could carry in a single lift was an attractive counter, and a small freighter with a ducktail could deliver a small ground base or two, something a Free Trader simply could not do.

(R1.69A2) SMALL FREIGHTER POWER PACK DUCKTAIL: A rarely-seen ducktail that added some additional power to a small freighter. Never used by standard freighters (which had no need for the power), this ducktail was designed for non-cargo charter missions, and provided power for science or other skids used in that role.

(R1.69A3) SMALL FREIGHTER WORKBOAT DUCKTAIL: A more common variation of the standard ducktail, and seen with virtually all skid combinations on small freighters. More often than not only one workboat was carried. Like the workboat skid, the small crews of the workboats compared to PFs made this ducktail feasible. A PF could temporarily dock to this ducktail, perhaps to evacuate crew casualties, but would never be carried by a freighter as it could not be rearmed or have its warp packs replaced (or de-ionized). Workboats had no warp booster packs and few weapons, and so were not restricted. Freighters cannot buy PFs (even as part of a battle force) but in a campaign where a PFT or other warship was lost or diverted, leaving a PF behind, the PF could at least be towed by a freighter with this ducktail. Cargo freighters almost never used this ducktail (unless they were going to a place where a workboat would be the most efficient means of unloading); it was designed and marketed for non-cargo charters such as asteroid mining, disaster relief, or survey/exploration. A freighter with this ducktail can be equipped with workboats (R1.PF7) purchased as part of the battle force as casual PFs, but not any other kind of PF. Skiffs (R1.52) cannot be carried by this ducktail, or indeed on any mech link.

(R1.69B) LARGE FREIGHTER DUCKTAIL (L-DT): Large freighters already included a tractor beam, but the owners of many of them saw the possibility of increased trade with marginal planets if they could carry a few HTS shuttles. The Large Freighter Ducktail brought two HTS shuttles with it. Needless to say, the freebooters who operated the Free Traders were more than a little resentful of the appearance of ducktailed ships poaching their trade routes. These bad feelings may actually be one of the reasons that Skids appeared since the added phasers could make a convincing argument to a Free Trader captain.

There are reports that at least one or more Large Freighters operate two or four F-7 fighters from its ducktail,

and at least one known case of a large freighter landing four GAS shuttles as part of a clandestine pirate raid.

(R1.69B2) LARGE FREIGHTER POWER PACK DUCKTAIL: This ducktail added additional power to large freighters, but was used primarily by non-cargo charters carrying skids that needed the extra power. Cargo carriers had little need for such power and would never pay for one, but a ship with such a ducktail might be part of a convoy during transit.

(R1.69B3) LARGE FREIGHTER WORKBOAT DUCKTAIL: After the advent of workboats, this variant ducktail was not unusual on independent large freighters on non-cargo charters such as asteroid mining, disaster relief, or survey/exploration. Even large freighters operated by the big merchant consortiums used this ducktail due to the increased ability to move cargo from space to the surface of a planet and vice versa, or even to make deliveries to more than one location in a given system at virtually the same time. Time saved is money earned. A freighter with this ducktail can be equipped with workboats (R1.PF7) purchased as part of the battle force as casual PFs, but not any other kind of PF. Skiffs (R1.52) cannot be carried by this ducktail, or indeed on any mech link. The HAM in *Captain's Log #35* had an earlier version of this ducktail; the version in this product is correct.

PLANETARY OPERATIONS BASES

(R1.72) CIVILIAN PLANETARY OPERATIONS BASE (CPOB): A base of this type is only found on a relatively prosperous colony that has expanded to moons, asteroids, or other planets within its system. The base's function is not combat, but the smooth operation of commerce within the system. To this end, the base is staffed with civil administrators, law enforcement and customs personnel, and maintenance personnel from the colony's government. It is not part of any fleet, except when martial law is declared. Thus the base has relatively sketchy combat systems (minor phaser defenses and weak shields compared to similarly-sized bases). Cargo handling (both outgoing and incoming) is the major factor in the base's design. It operates under the rules for small ground bases (R1.14) unless otherwise noted.

The skiff pads are merely cleared landing areas with minimal support facilities needed for skiffs. They provide no capability to operate PFs (i.e., they cannot rearm PFs, or install warp packs), but they can perform some repairs on PFs. Such repairs would be limited to the power systems (but not the warp packs), phasers, hull, cargo, tractor (if the PF has one), control systems (i.e., Bridge, sensor, scanner, but not special sensors), and probe launcher (if the PF has one). The skiff pads are targets for damage (and thus presented on the SSD) because they do include various connections to refuel and repair skiffs. Generally, a base of this nature will include one or two Security skiffs (R1.53) (sometimes none) and two or three Seeker skiffs (R1.52). The remaining pads are simply there to accommodate traffic, i.e., Seeker skiffs and modular couriers (R1.54), from the colony's outlying development projects. No skiffs or couriers are included in the base's BPV.

There is a stockpile of 12 type-I drones for each drone armed Security skiff that operates from the base (these will be plasma-D torpedoes if the skiff uses plasma-D torpedoes). For purposes of (FD2.45), determine the drone load-out of the skiff(s) and the remaining drones will be proportional.

Like the skiff pads, the shuttle arrangement is not intended to have a shuttle parked in every spot, and the base's BPV assumes only the shuttles listed in this rule are present. A base of this type will normally have an admin shuttle (R1.F1), a ground attack shuttle (R1.F4), four heavy

transport shuttles (R1.F5), a recovery shuttle (R1.F22), a heavy recovery shuttle (R1.F23), a salvage shuttle (R1.F24), and a rescue shuttle (R1.F25). The ground attack shuttle will only be present if there are no Security skiffs. If there are Security skiffs, the ground attack shuttle will instead be a second admin shuttle (no change in BPV). The remaining eight spaces are there to accommodate shuttles from visiting ships, personnel from the various system development projects, or wealthy merchants. Of course, they could also be used to accommodate one or two heavy (R1.F13) or very heavy (R1.F14) freight shuttles [or yachts (R1.F15) or (R1.F16)]. Any additional shuttles a player wishes to have present at the base (taking up the empty landing spots) must be purchased as part of the overall force.

The shuttle positions provide no special capability to rearm fighters, and their ability to even service them is limited as the base has only the two deck crews provided by (J4.814) (i.e., it is not a carrier). Note that if a base's Security skiff operates drones, then the "Kzinti Weightlifting Team Rule" (J4.8962) could be used to load drones onto a fighter's (or MRS shuttle's) rails. [The (J4.8962) system could also be used to load (and activate) plasma-D torpedoes provided they were available (i.e., were used by a Security skiff stationed at the base)]. As with fighter ground bases (R1.28A) the "bay" is outdoors and there is no restriction on the number of shuttles, skiffs, and/or couriers that can launch or land during any given impulse.

Also associated with such a base, but not shown on the SSD, are landing pads for small (size class 4) ships capable of landing to load and offload cargo, such as Free Traders (R1.9) and variants of it and the occasional Federation Express (R1.11). There are normally two such pads, but sometimes three. Any such ships would land outside the shields of the base (and would be separate targets for all purposes), and refueling, repair (using mobile gantries also not shown on the SSD), and cargo transfer would be done by trucks. Note that in this instance the trucks are purely civilian types and have no combat effect, not even to absorb casualties in a ground combat location (D15.0). In a future ground combat module they might be available to help transport troops (or civilians).

The base does include a larger than normal number of spare shuttles in storage and these include (for campaign purposes): one each: admin, ground assault (this is an admin shuttle if the base has assigned Security skiffs), heavy transport, recovery, salvage, and rescue shuttles.

An exception to armaments: A Federation version of this base might include kits to convert its heavy transport shuttles into B-26 bombers as described in *Captain's Log #31*. The heavy transport shuttles would not always be in this configuration, and players must either agree that they are (if not playing a specific scenario), or will be provided with the conversions in special scenario rules. A base with B-26 bomber kits will include a stockpile of 12 type-I drones for each such kit. Increase the BPV of the base by the difference in the cost of a heavy transport shuttle and a B-26 (three points) in each case, plus the cost of drone speed upgrades. Special drones are available under the normal rules. The base is not a "carrier" and cannot lend electronic warfare to the bombers, which are not considered a squadron except for purposes of determining the number of special drones that are available (FD2.45). [For purposes of (FD2.45), determine the drone load-out of each of the bomber kits, and the remaining drones will be proportional.] Again note that the base has only two deck crews, and is not a carrier (and thus cannot purchase additional deck crews under Commander's Options), and will have a difficult time rearming the B-26s.

This unit is treated as a medium ground base (P2.76).

SSD is in *Module R11*. Use the counter for a small ground base.

(R1.73) CIVILIAN SMALL OPERATIONS BASE (CSOB): A smaller version of the CPOB, a base of this type is only found on a relatively prosperous colony that has begun to expand to moons, asteroids, or other planets within its system. The basic background of the CSOB is identical to that of the CPOB, so only differences will be noted here.

Generally a base of this nature will include one or two Security skiffs (R1.53) (sometimes none). The remaining pads are simply there to accommodate traffic, i.e., Seeker skiffs and modular couriers (R1.54), from the colony's outlying development projects. No skiffs or couriers are included in the base's BPV.

See (R1.72) for supplies to support skiffs.

Like the skiff pads, the shuttle arrangement is not intended to have a shuttle parked in every spot, and the base's BPV assumes only the shuttles listed in this rule are present. A base of this type will normally have an admin shuttle (R1.F1), two heavy transport shuttles (R1.F5), a recovery shuttle (R1.F22), and a rescue shuttle (R1.F25).

Such a base will normally have one, sometimes two, landing pads (not shown on the SSD) for small (size class 4) ships capable of landing to load and offload cargo and these operate just as those in (R1.72) do.

The base has two spare shuttles, one of which is an admin shuttle, the other can be any other type of single space shuttle, including, for example, a salvage shuttle. For campaign purposes, the base might move one of its existing shuttles into storage in order to activate a stored shuttle for some special purpose (like salvage).

An exception to armaments: A Federation version of this base might include kits to convert its two heavy transport shuttles into B-26 bombers as described in *Captain's Log #31*. The heavy transport shuttles would not always be in this configuration, and players must either agree that they are (if not playing a specific scenario), or will be provided with the conversions in special scenario rules. See (R1.72) for how this is done.

SSD is in *Module R11*. Use the counter for a small ground base.

AUXILIARIES

(R1.74) HEAVY AUXILIARY TROOP TRANSPORT (FTH): An outgrowth of the adoption of heavy auxiliaries, the FTH proved to be little more than an embarrassment. The FTH's only real advantages over the large troop freighter (besides the weapons suite) were that it had 50% more cargo volume (allowing it to carry more supplies to support a landing operation) and a 20% increase in transporter capacity, but this was at the cost of an 8% decrease in shuttle capacity and (more critically) nearly halving the tactical speed. Slower than the large troop freighter (R1.19), it proved unsatisfactory for use in special attack forces. While normal large troop freighters were hardly speed demons, they were much faster than the FTH, and better able to respond quickly to a changing strategic situation. The added weapons, cited by the designers as making the ship "self-escorting", did not make up for the longer time it spent inside an enemy's fields of fire.

Ultimately the few ships of this design that were produced by the various races served out their operational lives ferrying replacements in low-priority areas.

Maneuver Limit: The FTH cannot accelerate by more than five movement points per turn (warp and impulse combined) or double its current speed. It cannot disengage by acceleration.

Romulan FTHs cannot cloak.

SSD and counter are in *Module R11*.

(R1.75) LARGE AUXILIARY HEAVY FIGHTER CARRIER

(LAH): Auxiliary carriers were originally intended to operate in a defensive role, protecting convoys and colonies where there were not enough fleet ships to do the job. As such, they were designed to operate defensive fighters. As the war progressed, many auxiliaries found themselves pressed into the fighting closer and closer to the front lines where their fighters, which were frequently less than first-class, were at a significant disadvantage. Eventually every race took several ships of the AxCVA class and converted them (some were built new) to this design as heavy fighters became more available, the concept being to use them as a follow up assault force. The change was not popular with the ships or their crews, as even with the heavy fighters' heavy weapons the ships were simply not fast enough to survive long in the front lines.

Data, including weapons, is identical to that found in (R1.13) for the AxCVA, except that half of the fighters are replaced with the race's heavy assault fighter. [Note: the Federation uses A-20s or F-101s, see (R2.102) for F-111s.] The ship has two shuttle bays, transfers are not possible between them. The following additions are made to (R1.13):

LDR: Weapon A is phaser-1; other weapons and fighters are the same as Lyrans.

Seltorians: Weapon A and Weapon C are phaser-1, Weapon B is phaser-3. Use the same fighters as the Klingons.

Vudar: Weapons and fighters are the same as the AxCVA in Module F2.

Maneuver Limit: The LAH cannot accelerate by more than five movement points per turn (warp and impulse combined) or double its current speed. It can disengage by acceleration.

Romulan LAHs cannot cloak.

SSD and counter are in *Module R11*.

(R1.76) SMALL AUXILIARY HEAVY FIGHTER CARRIER

(SAH): This ship's background is identical to that of the LAH (R1.75) except that it only operated one fighter squadron.

Data, including weapons, is identical to that found in (R1.13) for the AxCVL, except that instead of the 12 fighters indicated the ship uses six heavy fighters. [Note: the Federation uses A-20s or F-101s, see (R2.103) for F-111s.] The following additions are made to (R1.13):

LDR: Weapon A is phaser-1; other weapons and fighters are the same as Lyrans.

Seltorians: Weapon A is phaser-1, Weapon B is phaser-3. Use the same fighters as the Klingons.

Vudar: Weapons and fighters are the same as the AxCVL in Module F2.

Romulan SAHs cannot cloak.

Maneuver Limit: The SAH cannot accelerate by more than five movement points per turn (warp and impulse combined) or double its current speed. It can disengage by acceleration.

SSD and counter are in *Module R11*.

(R1.77) LARGE AUXILIARY SCOUT (LAS):

Technically designated as a "Listening Post Ship", this class was never meant to enter combat, being designed in peacetime to provide wide-area scanning (with both passive and active systems). All races built ships of this type, based on the hulls of large armed freighters, and used them extensively (with a police ship in close attendance) to monitor areas not easily covered by the sensors on bases. During the original Coalition assault on the Hydrans and Kzintis in the General War, the superiority of Coalition scouts forced the Hydrans

and Kzintis to rely on their auxiliary scouts for critical battles. The ships were slow and vulnerable and did not survive long in combat, and most were caught and destroyed in pursuit battles. Other races kept their auxiliary scouts out of combat areas, often using them as part of the escort for critical convoys. Probe launchers had ten probes.

Because of their rather unique mission, it was not unusual prior to the General War for listening post freighters to be equipped with an MRS shuttle to use as a scout to check on unusual sightings. This was almost never done during the General War due to the small numbers of MRS shuttles produced, but some listening post freighters did manage to acquire one or replace one that was lost.

WEAPONS OF THE LARGE AUXILIARY SCOUT

RACE	W1	W2	W3
FEDERATION	Ph-1	2xDrn-A/B 2xDrn-G	Ph-3-RA
KLINGON	Ph-2	4xDrn-A/B	Ph-3-RA
ROMULAN	Ph-1	2xPI-D-LS 2xPI-D-RS	Ph-3-RA
KZINTI	Ph-1	2xDrn-A/C 2xDrn-A/B	Ph-3-RA
GORN	Ph-1	2xPI-D-LS 2xPI-D-RS	Ph-3-RA
THOLIAN	Ph-1	2xPh-3-LS 2xPh-3-RS	2xWeb/ Snare -LS/RS
HYDRAN	Ph-2	4xFighter*	Ph-G-RA
LYRAN	Ph-2	2xPh-3-LS 2xPh-3-RS	ESG
ISC	Ph-1	2xPI-D-LS 2xPI-D-RS	Ph-3-RA
LDR	Ph-1	1xPh-G-LS 1xPh-G-RS	ESG
SELTORIAN	Ph-1	2xPh-3-LS 2xPh-3-RS	Ph-3-RA
VUDAR	Ph-2	2xPh-3-LS 2xPh-3-RS	Ph-3-RA

SEEKING WEAPON CONTROL: Auxiliary scouts armed with seeking weapons can control a number of seeking weapons equal to their sensor ratings (F3.21). Auxiliary scouts without seeking weapons, e.g., Tholian, Hydran, Lyran, LDR, Seltorian, and Vudar, can control a number of seeking weapons equal to half their sensor rating (F3.211).

*The fighters are part of the existing shuttle bays, e.g., the two shuttle bays in the rear hulls each include two admin shuttles and facilities for two Stinger fighters, all sharing the same hatch. There are no launch tubes. These ships normally operated Stinger-1, Stinger-2, or Stinger-F fighters. They never operated Stinger-H, Stinger-E, or Stinger-X fighters.

Romulan LASs cannot cloak.

Maneuver Limit: The LAS cannot accelerate by more than five movement points per turn (warp and impulse combined) or double its current speed. It can disengage by acceleration.

Special sensors are destroyed on "phaser" damage points.

SSD and counter are in *Module R11*.

(R1.78) SMALL AUXILIARY SCOUT (SAS): As with the LAS, this ship was designed before the General War as a listening post that would stay out of combat and provide wide-area scanning to support fleet operations. Probe launchers had ten probes.

Most of the Alliance races believed that the front lines would move at a relatively low speed and that deep raids would be unusual and limited to the handful of CFs and

DNLs. Auxiliary scouts could stand back from the battle in relative safety and tell admirals where enemy fleets were moving.

WEAPONS OF THE SMALL AUXILIARY SCOUT

RACE	W1	W2
FEDERATION	Ph-1	2xDrm-G
KLINGON	Ph-2	2xDrm-A/B
ROMULAN	Ph-1	1xPI-D-LS
		1xPI-D-RS
KZINTI	Ph-1	2xDrm-A/C
GORN	Ph-1	1xPI-D-LS
		1xPI-D-RS
THOLIAN	Ph-1	1xPh-3-LS
		1xPh-3-RS
HYDRAN	Ph-2	2xFighter*
LYRAN	Ph-2	1xPh-3-LS
		1xPh-3-RS
ISC	Ph-1	1xPI-D-LS
		1xPI-D-RS
LDR	Ph-1	1xPh-G-LS
		1xPh-G-RS
SELTORIAN	Ph-1	1xPh-3-LS
		1xPh-3-RS
VUDAR	Ph-2	1xPh-3-LS
		1xPh-3-RS

SEEKING WEAPON CONTROL: Auxiliary scouts armed with seeking weapons can control a number of seeking weapons equal to their sensor ratings (F3.21). Auxiliary scouts without seeking weapons, e.g., Tholian, Hydran, Lyran, LDR, Seltorian, and Vudar, can control a number of seeking weapons equal to half their sensor rating (F3.211).

*The fighters are part of the existing shuttle bay, e.g., the shuttle bay in the rear hull includes two admin shuttles and facilities for two Stinger fighters, all sharing the same hatch. There are no launch tubes. These ships normally operated Stinger-1, Stinger-2, or Stinger-F fighters. They never operated Stinger-H, Stinger-E, or Stinger-X fighters.

Romulan SASs cannot cloak.

Maneuver Limit: The SAS cannot accelerate by more than five movement points per turn (warp and impulse combined) or double its current speed. It can disengage by acceleration.

Special sensors are destroyed on “phaser” damage points.

SSD and counter are in *Module R11*.

(R1.79) COMMUNICATIONS RELAY STATION (CCS): This is a standard systems activity maintenance station (R1.30) (using those rules except as modified herein) with a special communications module (seen only on such stations and so not presented as a separate module but as part of the complete base) and a power augmentation module. The power augmentation is necessary to boost the signals; no other augmentation modules were ever docked to such a station. There are dozens of these in any empire serving as the switchboards for civilian message traffic (which is always heavier than the military’s traffic simply because there are so many more civilians transmitting). Duty at these stations is boring since they had to be located outside of planetary systems to keep interference with transmissions to a minimum. Pirates ignored these stations (as their operations made as much use of them, however encoded, as any other non-military operation) as there was no benefit in attacking them. Even military raiders largely ignored them as their transmissions served as useful beacons while navigating in enemy space.

The weapons are identical to those found on a SAMS station operated by the race with these additions:

Seltorian: Heavy Weapon is PC-360°; Ph-X are phaser-1s.

Vudar: Heavy Weapon is IC-360°; Ph-X are phaser-2s, ionization costs 0.33 points of power.

SSD and counter are in *Module R11*.

(R1.80) CONSTRUCTION DRY DOCK (CDK): Docks of this type are found in all major shipyards throughout known space. They are called “dry docks” because every effort is made to minimize the effects of gravity within their confines. They are fixed orbital installations. While they are very sturdy, they are simultaneously very fragile. They bear a superficial resemblance to fleet repair docks, but they are not fleet repair docks. Building one of these is a significant part of a given empire’s economic potential. They cannot be moved by any means; trying to do so would tear them apart. For this reason they tend to be well protected by being in the very core region of the empire and orbiting near a starbase (or at least the largest orbital defense structure a system has) where its weapons can protect them, and they can be covered by any planetary defenses. Empires do build smaller satellite shipyards in other systems to diversify production, take advantage of local resources, and spread the risk of enemy attacks. This was done, however, only in the General War when economies had been mobilized for total economic efforts. It should be noted that every starbase has one of its docking modules fitted to build frigate-type vessels as an emergency measure. All dry docks are essentially the same, differing only in their scale (and thus the maximum size of hull that can be constructed within).

One of the most significant things about dry docks (in terms of game play) is their relative resistance to damage. This is not so much a reflection of their toughness (as noted they are very fragile), but of their highly-dispersed mass.

Dry docks are designed to spread out their mass (which is still hundreds of metric tons more than the typical ship, even a dreadnought, being constructed within their frames) as much as possible, and to have as little inherent mass as possible. This is to minimize the effects of their own gravity (all that metal) on the assembly of hulls within their frameworks. This makes it easier to assemble the various pieces of a ship in subsections, and to join the differing sections as the assembly process proceeds without interference from the inherent gravitational attraction of the dock itself (even as infinitesimally small as it is compared to the gravity well of a planet or other large body). Starships, driven at translight speeds through combat conditions, are under tremendous strain, and their construction must be nearly perfect or the tremendous forces of their weapons and engines will rip them apart. Gravity must be minimized (so it can be rigidly controlled) to avoid having any elements of the ship “bent” however infinitesimally or installed under unintended stress conditions. The tolerances for warp fields generated by ships are so tight that even the slight imperfections caused by these competing micro-gravity fields can create a fluctuation that will rip a ship apart at high warp. By reducing this effect, it is possible to assemble large hulls with less structural mass during the building process, resulting in a lighter ship. (This is one of the reasons Romulan Eagle series ships are so massive with relatively small internal volume.)

The result of all this dispersal means that, if there is no hull under construction currently inside a dry dock, it cannot be harmed by direct fire weapons outside of a range of three hexes. This simply reflects that the dispersed nature of a dry dock will literally allow the energy of such weapons to pass

right through it. Beyond that range even plasma torpedoes and drones will fail to acquire an adequate targeting solution.

Dry docks have no weapons of their own. (The added mass of such weapons would interfere in the construction of ships.) They are designed to divert as much power as possible to ECM and to an inherent special sensor to maximize their electronic warfare protection.

Shipyards are the center of a massive logistics effort that extends not just to the planet around which they orbit, but to the far-flung borders of the empire and lowliest asteroid miner in his prospecting shuttle. Ores and products flow to the various industrial centers to be converted into the parts of a starship, and then to the dry dock to be assembled. The dry docks are the very heart of an empire, the system that ultimately converts these materials into the muscle and sinew, i.e., the ships, that protects it all.

Dry docks have large landing platforms that can accommodate large shuttles, skiffs, and (later) cargo PFS delivering material to be incorporated into a ship being constructed. This is possible due to the open nature of their design. (The ability of a dry dock to land VFS and HFS shuttles does not create an opening for basing bombers at orbital battle stations or starbases, which have nothing in common with the design of dry docks.) There are docking facilities for Free Traders, APTs, and freighters to deliver larger components, such as the engines that will ultimately bring the ship to life, but these components are delivered at the start of the construction process so as not to have gravitational effects.

Dry docks have all the functions of a fleet repair dock, and can operate as such (however static) when not currently constructing a new ship. While building a ship, nothing larger than Size Class 5 can dock to the dry dock externally (without causing gravitational anomalies in the construction in process). The low life support cost reflects that most of the people involved in ship construction on a dry dock are actually not present. (The number of crew units shown reflects people involved in maintenance on the dock itself and work inspectors who do most of their labor in extremely advanced space suits.) Almost all of the work is done through remote systems with the workers sitting in offices or even their homes, which again saves mass (by reducing the need for life support systems). There are, however, various offices and conference rooms, as well as quarters for visiting personnel, and emergency medical facilities, built into the dry dock. Personnel that actually do work on dry docks are transported up from the planet, and back down to the planet when their work shift ends. Construction work, however, goes on around the clock. Shifts on dry docks around Earth, for example, are six hours in length with personnel logging into their work stations (or in the case of the maintenance crews, arriving) from Europe, the Americas, the Pacific region, and Asia in rotation. In space, there is no night, and with remote systems and transporters, no reason not to have a 24-hour work schedule.

No augmentation modules can be added to a dry dock. All dry docks have positional stabilizers (G29.0) and operate minimal shields to protect the workers and the ship under construction from stray debris.

SSD and counter are in *Module R11*.

(R1.81) ADVANCED TECHNOLOGY FLEET REPAIR DOCK (FRX): All races found that pulling their X-ships back to central repair facilities in their core regions, or trying to keep them based on the few bases that could be fitted with advanced technology, was unworkable. The time delays in transit, or the strategic limitation of being tied to a local base was simply unacceptable. Unfortunately, the technology was too new and too hard to repair without a dedicated system.

So, as they had when they first ventured to the limits of their empires, the various races began fielding advanced technology fleet repair docks for the express purpose of unchaining their X-ships and releasing them to go where the fighting was.

The weapon options are the same for non-X FRDs, except that they are the appropriate advanced technology versions, i.e., all phaser-2s (most marked as W2) are phaser-1X. The Vudar use advanced technology IPGs in W4. FRXs otherwise use the rules of (R1.10) except as modified by the X-technology rules.

SSD and counter are in *Module R11*.

(R1.82) SMALL FAST FREIGHTER (F-SF): When the Alpha Quadrant began planning Operation Unity, they realized that the logistic burden would be decisive. With such a long logistics tail, the lead-time for a need and its eventual delivery would be impossible to calculate. Some of the burden would be carried by tugs, LTTs, and theater transports (using their internal cargo volume) and able to move faster than freighters. Unfortunately, it was more than apparent that the tugs and LTTs would be heavily involved in building the bases that would be needed to support the advance, and the transports had many duties to perform in the Alpha Quadrant, where cut off Andromedans were still active. Much of the logistic burden was going to be carried by the old freighters, and they were just too slow to react quickly to distant changes in need. In addition, the APTs just did not have the cargo volume for what was anticipated. The result led to the construction of a number of small fast freighters. While not as fast as true warships, they were faster even than the armed freighters. Furthermore, their pods were designed to be disassembled and converted into the sections of bases being constructed. In this way the F-SF could make a delivery, refuel, and immediately start the return trip. Records are unclear as to how many freighters of this type were built, but ultimately only a few survived Unity, being lost mostly to their engines burning out from the near-constant strain. Unity would, however, not have been possible without them.

Maneuver Limit: The F-SF cannot accelerate by more than five movement points per turn (warp and impulse combined) or double its current speed. It can disengage by acceleration.

SSD and counter are in *Module R11*.

(R1.83) LIGHT MONITOR (LMON): The original monitor, it was first deployed in response to Orion operations in Y130. While it was adequate in its time period, larger Orion raiders and more effective enemy warships was soon overwhelmed it. Light monitors remained in production because they were militarily cheap and freed real warships for other duties. Light monitors can use the pallets of a monitor with no change except that they cannot be fitted with a space control pallet. The ship otherwise operates under the rules for monitors in (R1.22), including maneuver limits. Note that the Romulans do not operate light monitors prior to Y161, and that Romulan light monitors can cloak.

The weapons on the design for each race are as follows (weapon B is 360° unless otherwise noted):

RACE	A	B	C/D
FED	4xPhot-FA	4xPh-1	Drone-G
KLINGON	4xDisr(30)-FA	4xPh-2	Drone-B
ROMULAN (Y161)	3xPI-G-FA	2xPh-1	Plas-F-LP/RR

KZINTI	2xDisr(30)-FA	4xDrone-A	2xPh-1-LS 2xPh-1-RS
GORN	3xPl-G-FA	2xPh-1	Plas-F-LP/RP
THOLIAN	4xDisr(30)-FA	4xPh-1	Web generator
THOL-W (Y184)	2xDisr(30)-FA 1xWC-FA	4xPh-1	Snare generator
HYDRAN*	4xFusion-FA	1xFus-LS 1xFus-RS	Ph-2-LS/RS
HYDRAN* (Y160)	2xHellbore-FA	1xFus-LS 1xFus-RS	2xPh-2-LS 2xPh-2-RS
LYRAN LDR	4xDisr(30)-FA	4xPh-2	ESG
ISC (Y165)	3xPlas-G-FA	2xPh-1	Plas-F (ISC Arcs)
LDR (Y163)*	4xDisr(30)-FA	4xPh-2	ESG
SELT (Y184)	4xPC-FA	4xPh-1	WB-FA
VUDAR (Y179)	4xIC-FA	4xPh-2	IPG

*Hydran Light Monitors replace 4xPh-3-LS with 2xPh-G-LS and 4xPh-3-RS with 2xPh-G-RS. LDR light monitors make the same change in Y165. The LDR had one light monitor received as a gift from the Lyrans in Y163, and returned it to the Lyrans (after removing the phaser-Gs) in Y168 in exchange for a larger monitor.

Known Ship Names: *Redoubt #10* (Federation). All empires, except the Orion Pirates and Andromedans, used units of the type. Some had names; some only had identification numbers.

SSD and counter are in *Module R11*.

(R1.84) FREE ESCORT CARRIER (FEV): A variant of the Free Trader. The need to have personnel to service the embarked fighters resulted in some of the cargo volume that nominally should have been available to carry fighters being converted to quarters. Like the armed cutter (R1.86), ships of this configuration appeared in areas where the government was not able to provide adequate security forces. The fighters embarked were almost always second-hand (and sometimes third-, fourth-, or fifth-hand) cast-offs that could be had cheaply. While the SSD has all six fighters being the same type, the most common fighter group was a mix of whatever was available (although at least one operated six F-7s). These ships never operated assault fighters (not even Federation A-6s), double-space fighters (it can carry double-space, but not larger, shuttles), or mega-fighters. Outside of Hydran space, they never operated phaser-G-armed fighters. They operated as small escort carriers to provide some security from raiders.

It is believed that the first ships of this class actually entered service more than 20 years earlier as a platform for prospecting shuttles in support of large-scale asteroid mining. One or more ships would accompany a large ore-processing freighter into an asteroid system and then help deploy the prospecting shuttles to other areas in the field. Ships of this class have been used, according to some reports, as “assault shuttle platforms” by corporations in cases of “contract negotiations”.

FEVs operated with no formal escorts, although sometimes another auxiliary would be more or less

permanently assigned to act in that role. (It would not have ready racks or any other supplies to service the fighters.)

Each of the option mounts can hold one of the listed weapons (on the SSD); write the option mount letter in the box provided for the system. Thus if the ship will have a phaser-2 and an ADD rack, write an “A” in one of the two phaser-2 boxes and a “B” in one of the ADD boxes (or vice versa). If both options were phaser-2, simply write “A” in one phaser-2 box and “B” in the other. Adjust the BPV of the ship for the weapons selected and for any refits as listed under the various seeking weapon tables. It is otherwise considered to be a “casual carrier” (J4.62).

This ship can use powered landings (P2.434); bonus (P2.431).

Known Ship Names: All empires, except the Orion Pirates and Andromedans, used units of the type. Some had names; some only had government-imposed identification numbers; some had both. Some names were used repeatedly, i.e., different colonies within an empire gave their own defense cutter the same name. Some names Federation colonies are known to have used included: *Taiyo*, *Unyo*, and *Chuyo*.

SSD and counter are in *Module R11*.

(R1.85) PRIME CORVETTE (PTC): A variant of the Prime Trader version of the Free Trader, the Prime Corvette was an effort to create a small combatant out of the ship. Ships of this type first entered service in Y135, and were used by most races.

Prior to Y165, PTCs operated by the Federation government were armed with one or two photon torpedoes. After Y165 they were usually armed with two type-G drone racks which allowed for higher combat speeds and easier maintenance.

The Klingons, Kzintis, and WYNs armed some PTCs with disruptors, and some with type-A drone racks (later with type-B, increasing the BPV by one point per rack). (There are no type-B racks on the SSD due to space considerations.) The Lyrans and LDR armed their PTCs with disruptors (in the two option mount positions) only. Disruptors on Klingon PTCs are limited to ten hexes range, all others have fifteen hexes range.

The Romulans, Gorns, and ISC armed some PTCs with a single plasma-G torpedo, and some with a pair of plasma-F torpedoes.

The Hydrans armed their PTCs with fusion beams. PTCs operated by the guilds never had phaser-Gs while those operated by the fleet sometimes replaced the two phaser-3s with a single phaser-G (same firing arc).

Phaser-X on versions of the PTC operated by civilians, Klingons, Hydrans, Lyrans, and Vudar are phaser-2s, otherwise they are phaser-1s. The Vudar operated a variant of the PTC with ion cannons in the option mounts (there is no ion cannon table on the SSD due lack of space). Some Jindarian caravans operated one or more PTCs with light rail guns (no rail gun table is on the SSD due to lack of space). The Seltorians are not known to have operated any PTCs, but if they did, it would probably have had particle cannons (no particle cannon table is on the SSD due to lack of space).

Civilian versions of the PTC cannot acquire T-bombs, but government versions can purchase T-bombs normally. Special scenario rules will provide whether or not a given PTC is a government or civilian version. In all cases, special scenario rules may define that, in fact, a PTC is operated by the government, but equipped with phaser-2s rather than phaser-1s due to low priority.

This ship can use powered landings (P2.434); bonus (P2.431).

Known Ship Names: *Paktar #7* (Federation). All empires, except the Orion Pirates and Andromedans, used units of the type. Some had names; some only had government-imposed identification numbers; some had both.

SSD and counter are in *Module R11*.

(R1.86) ARMED CUTTER (CUT): A variant of the Armed Priority Transport, ships of this type may have appeared when APTs were in squadron service. The data on them is actually somewhat unclear, but Y130 is the generally accepted date of general service for armed cutters. Living conditions aboard were extremely cramped, and overwork was a constant problem. More crew were needed, but there simply was not enough room to put more personnel aboard for extended patrol periods. These ships were most often used as a local defense unit (where the crew could get relief from the stress of the cramped conditions fairly easily), often with two or more duplicate crews so they could be rotated. They were also found as escorts for convoys, particularly when regular police ships were over tasked. When used in this role, it was not unusual for additional accommodations to be made on the escorted ships for the crews of the cutters.

On most, but not all, ships of this type, the drone racks were phaser-2s LS/RS prior to Y165. In that year, cutters operated by the Federation began conversion to type-G drone racks. Cutters operated by the Klingons, Kzintis, WYNs, and some Lyrans began conversion to type-A drone racks (and to type-B in Y175). The Romulans, Gorns, and ISC operated cutters with plasma-D racks. All other races (Tholians, Lyrans, LDR, Hydrans, Seltorians, Jindarians, and Vudar) continued to use phaser-2s. Note that the Y175 refit cost only applies in cases where the type-A drone racks are upgraded to type-B.

The 360° phaser (shown as a phaser-X on the SSD) was a phaser-1 in most cases, but was always a phaser-2 when operated by the Klingons, Hydrans, Lyrans, and Vudar, or when operated by non-governmental agencies (even within the Federation).

Transporter bombs were sometimes provided to cutters operated by civilians who were augmenting government forces.

Known Ship Names: All empires, except the Orion Pirates and Andromedans, used units of the type. Some had names; some only had identification numbers. Some names were used repeatedly, i.e., different colonies within an empire gave their own defense cutter the same name. Some names Federation colonies are known to have used included: *Minuteman*, *Sentinel*, and *Spirit*.

SSD and counter are in *Module R11*.

(R1.87) STRYKER LANDING BOAT (LB): This unit is a variant of the Seeker skiff (R1.52) and appeared shortly after skiffs were in widespread service. It was found that the Security skiff often did not have the manpower to deal with a local crisis (a riot at a mining installation, for example). A Stryker could carry a company of ten boarding parties and deliver them directly to the facility. Cargo holds on the Stryker were often used to deliver one or two ground combat vehicles (GCVs) or other supplies, and the mech link would be fitted with whatever shuttle was available to support the landing force (or, it could carry a cargo pack with another GCV or other supplies). Most local governments, which had a few Security skiffs for law enforcement, had a Stryker to handle the movement of police teams, but the ship ended up being used for everything from rotating mining station crews to moving VIPs.

Skiffs, including Seekers, Strykers, Security, and other types, could not be carried on mech links (they were not designed to be) so landing boats (and other skiffs) cannot be

used as “early sort-of PFs”. Skiffs can dock to ships under the rules for ships docking to ships, not under the rules for shuttles or PFs. During the various conflicts that occurred before the General War (and during the General War itself), it was not unusual for a clandestine base to be established near a selected target and numbers of LBs gathered there. Enemy forces would then be drawn off by operations elsewhere, and the LBs would then launch an assault on an otherwise lightly-defended colony before enemy fleet forces could be redirected to its defense. During the General War these attacks were often accompanied by escorting fighters. (One might assume that Security skiffs would be used, but these were operated by local police, not the fleet, which had its own ways of supporting Strykers.)

The basic LB has the same crew as the Seeker skiff and has no additional units. Boarding parties, GCVs, shuttles, etc. must be purchased separately and assigned to the LB, but no more than eleven boarding parties can be carried of which no more than one can be a special unit (commando, heavy weapon, or engineer). The cargo boxes can be filled with whatever the player wishes, subject to their maximum volume and the BPV the player is willing to pay. Any shuttle on the mech link must be purchased, and can be of any type except: fighter, minelaying, minesweeping, multi-role, or SWAC, and cannot be larger than size 2. If no shuttle is purchased, the mech link can be defined as carrying a cargo pack and filled with cargo under the same rules as the Stryker’s normal cargo boxes.

Note that while the LB must purchase whatever it is carrying in a scenario, it can be defined as empty (carrying nothing) when purchased and then, during the scenario, load boarding parties and cargo from another ship for transport down to a planet (or some other landing area). In such case, special scenario rules might define that at the start of a scenario various items and personnel on a supporting ship have already been transferred to the LB.

No SSD is provided. Make the following changes to the Seeker skiff SSD: Change NWO to Barracks.

Counters are provided for LBs in *Module R11*.

(R1.PF0) FAST PATROL SHIP VERSIONS

(R1.PF7) WORKBOATS: Skiffs had been in use since Y140. When interceptors (and later PFs) first appeared, they were originally built in many of the factories that had been producing skiffs (although when interceptors proved the concept, many more factories were built to produce PFs). Workboats were built in limited numbers during the late General War years to take over the tasks Seeker skiffs and modular couriers (once built in the same factories) normally performed. They had the added advantage that they could be fitted to mech links and quickly carried to their destinations or broken down and moved as cargo. After the General War ended (and before the Andromedan War really got started), many older PFs were converted to this design to get more life out of their comparatively fragile hulls, and many more were built since there was a growing need for small boats to look for resources. Workboats were basically de-militarized variants of the standard cargo PF. They were fitted with a tractor beam and transporter as found on PF leaders, but as there were virtually no weapons, and the engines were not rigged to work with warp booster packs, not as many crew were needed, making long term livability much improved. They only have shuttles on their mech links if the shuttle is purchased separately; it is not automatically there.

Workboats can never be fitted with warp booster packs (the connections are literally not there in order to make production of the boat as cheap as possible).

SSDs and counters are in *Module R11*.

(R2.0) UNITED FEDERATION OF PLANETS

(R2.132) HEAVY FIGHTER CARRIER (CAV): When A-20 fighters became available, the CVS *Forrest Sherman* was converted (during construction) to operate them. Initial operations of the A-20s were disappointing and there was much debate about replacing the A-20s with A-10s (rejected because the A-10s were even slower than the A-20s and even harder to produce), or even mixed squadrons of F-18s and A-10s. The admiralty had decided to convert the ship into a standard CVS when a breakthrough in engine design made the A-20F effective.

This ship can control a number of seeking weapons equal to double its sensor rating.

The shuttle bay is a tunnel deck (J1.58).

Known Ship Names: 1965 *Forrest Sherman*, 1966 *Yamaguchi*, 1967 *Curtis LeMay*, 1968 *Henry Arnold*, and 1969 *Omar Bradley*.

Year	Escorts	Fighters
Y177-179	NAC, DWA or FFA	6xA-20
Y179+	NAC, DWA or FFA	6xA-20F

SSD and counter are in *Module R11*.

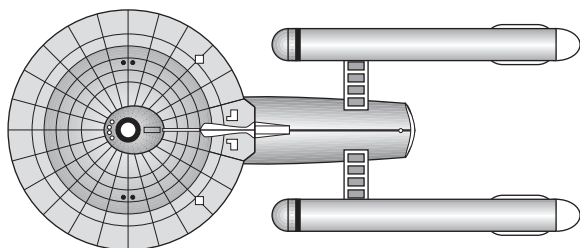

(R2.133) DIVISION CONTROL SHIP (DCS): Mounting the superb F-111 heavy attack fighters, this ship was one of the first division control ships to enter service in the Alpha Octant. The design was a variation of the CVD, and the first ship in the class began construction as such a ship. Changes to the CVD saucer section were minimal (involving the replacement of the forward phaser battery with special sensors), but were more radical in the secondary hull, which was slightly enlarged to better support the F-111s on mech links. The ships were considered a completely different class than the CVDs, resulting in a different naming convention (ancient leaders as opposed to Terran rivers). The ships proved effective in hunting down the Andromedan RTN during the Andromedan War. As with the CVD design, SWAC shuttles were sometimes assigned to these ships, but such occurrences were very rare.

This ship can control a number of seeking weapons equal to double its sensor rating. Special sensors are destroyed on "phaser" damage points.

Known Ship Names: 1970 *Vercingtorix*, 1971 *Boudica*, 1972 *Clovis*, and 1973 *Surena*. At least three more ships of this class were built.

Year	Escorts	Fighters
Y178-180	NAC, DWA or FFA	12xF-18B, 6xF-111
Y180-183	NAC, DWA or FFA	12xF-18B+, 6xF-111
Y183+	NAC, DWA	12xF-18C, 6xF-111

SSD and counter are in *Module R11*.

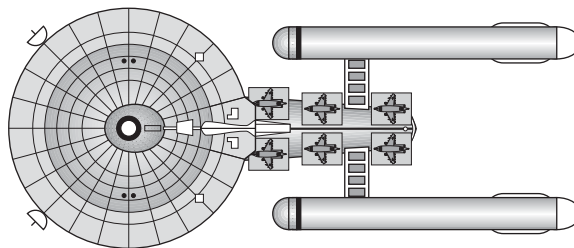

(R2.134) NEW HEAVY FIGHTER CARRIER (NHA): While grouped in the ship list with the NHVs, these were a separate sub-class carrying A-20s. The ships were otherwise identical to NHVs and operated in much the same manner, i.e., they never had SWAC shuttles assigned to them, and used the same escorts.

Known Ship Names: 1693 *Rene Fonck* and 1694 *Ivan Kozhedub*.

Year	Escorts	Fighters
Y177-179	NAC, DWA or FFA	6xA-20
Y179+	NAC, DWA or FFA	6xA-20F

This ship can control a number of seeking weapons equal to double its sensor rating. Special sensors are destroyed on "torpedo" damage points.

SSD and counter are in *Module R11*.

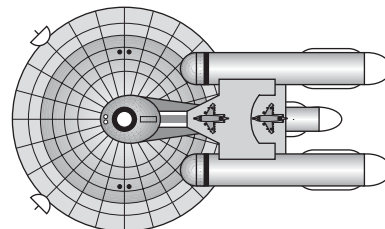

(R2.135) SCOUT POD (P-SC): This pod was a curious pre-General War design, from a time period when no one knew what role long-range scanners and electronic warfare would play in the coming conflict. It was championed by budget-minded members of the Federation Council because of its multiple uses. In peacetime, it could temporarily improve the sensor network in a given area, helping to stop piracy and smuggling. (This proved of little help.) In wartime, it could be deposited in open space and used by an admiral to coordinate ships and other forces over a wide area. (The only attempt to actually do this proved disastrous as a Klingon fast raider destroyed the pod, disrupting control over a wide area.) It could reduce the number of ships needed to patrol a border by providing enhanced sensor coverage there. (A pod was assigned to the Romulan border, and the number of ships there was reduced; the pod did not help coverage and the thin border patrols were overwhelmed on the Day of the Eagle.) It could be carried by a tug and used as a survey ship. (Tugs could never be spared for such things.) It could be carried by a tug and used as a combat electronic warfare platform (a mission considered unlikely to be needed, and led to the loss of a valuable tug when Klingon electronic jamming forced the Federation to try this). The basic design of this pod (and two pods under construction when the Klingons invaded) was modified to create the light battle pod to be used by the LTT. This is a single-weight pod.

Special sensors are destroyed on "phaser" damage points.

SSD is in *Module R11*. Use any pod counter.

(R2.136) HEAVY FIGHTER POD (P-HVL): The Federation equivalent of a PFT pod turned a tug into a carrier with six F-111s on external mech links. Rule (R2.R5) does not apply, and all of the cargo space is for expendable weapons (drones, chaff, booster packs, etc.). This was an operational combat pod, unlike the P-FCF (R2.101) which was used to ferry replacement F-111s to re-equip front line squadrons. This is a single weight pod.

Year	Escorts	Fighters
Y181+	None	6xF-111

This pod can control a number of seeking weapons equal to its sensor rating; this control ability is added to the tug it is attached to. Special sensors are destroyed on "phaser" damage points.

SSD is in *Module R11*. Use any pod counter.

(R2.137) LIGHT POLICE CARRIER (POV): As fighters became more common, the Federation Police Service began agitating for some of the fighter production to be diverted to them. In Y171, the first of a new class of light carriers, the *Bolander*, entered service. This ship was the prototype carrying a flight of six F-8 fighters. Initial tests were not satisfactory and serious consideration was given to dropping the idea. (The Federation Council was not overly interested in funding yet more fighter production in addition to what Star Fleet was demanding.) Before the ship could be scrapped, the Klingons invaded, and the *Bolander* was included in a convoy hastily assembled to take supplies to the front. The convoy was attacked by a small force of Orions, and the *Bolander's* fighters scored several significant drone hits. (Later analysis would prove that these drone hits were a fluke; the Orions simply had not been aware that the convoy had fighters.) With more funds being made available to fight the war, the police began acquiring more POVs. The new ships included the plus refit, which was retrofitted to the *Bolander* (which increased the ability of the ship to control drones from three to six).

Many have commented on the unusual size of the POV's shuttle bay, but the police felt that the extra shuttles allowed the ships to be customized for special roles (GAS shuttles to raid a small pirate lair, SAR shuttles, etc.). The ships never received heavy fighters or first-line fighters (F-14s). They were slow to get F-18s, but as fighter production picked up, the delay between upgrades being made to the F-18 and those finding their way into POV shuttle decks was reduced. The ships usually operated alone, but any of them might be paired with another cutter to serve as its escort. Unlike the PVs, no POV was ever assigned a fleet escort.

The shuttle bay is a tunnel deck (J1.58) with a hatch on each side of the ship's hull.

Known Ship Names: *Bolander, Ballard, Stivers, Russert, Pembleton, Brodie, Lewis, Giardello, Munch, Crosetti, Bayliss, and Felton*.

Year	Escorts	Fighters
Y171-172	None	6xF-8
Y172-177	1xPol or None	6xF-8
Y175-181	1xPol or None	6xF-18
Y179-184	1xPol or None	6xF-18B
Y181-186	1xPol or None	6xF-18B+
Y184+	1xPol or None	6xF-18C

This ship can control a number of seeking weapons equal to its sensor rating. This ship is nimble (C11.0).

SSD and counter are in *Module R11*.

(R2.138) NATIONAL GUARD SURVEY CRUISER (GSR): An anomalous ship in that to be effective it had to be in more continuous service than most National Guard ships. The *Amerigo Vespucci* was almost continuously on active service although it was never deployed in the *Second (Exploration) Fleet* zone. There was, however, a great deal of Federation space that was not completely surveyed, and the *Vespucci* spent most of its time in the region of space between the Federation capital and Gorn space. Assignment to the ship was strictly voluntary, with the guardsmen accepting a minimum of a one year active duty commitment to serve on the ship (and that only if there was an opening for his specialty). Still, there were many Federation citizens who had served in the Second Fleet who found that they were not yet ready to put the thrill of discovery behind them. The *Vespucci* itself was an upgraded old YCA hull that had been converted to the design as an experiment to see if money could be saved doing such conversions rather than building newer ships. Like the CL, the conversion was not a satisfactory one, and the *Vespucci* was the only ship of her design. But like the CL conversions, she eventually gave excellent service, perhaps due to the greater experience of even her lowliest crewman compared to the GSCs.

The *Vespucci* was fitted to operate two fighters at the same time as the other survey ships.

Known Ship Names: 1011 *Amerigo Vespucci*.

SSD and counter are in *Module R11*.

(R2.139) (NEW) FAST LIGHT CRUISER (NLF): This design was first proposed at the same time as the NCL. The concept of raiding ships was then the hot ticket item. It was not built because of questions about the strain on the engines and the hull form (borne out by problems the NCL had with safely executing a High Energy Turn). By Y173, the concept was revived as a means of getting more raiding ships. The first ship of the class, *San Martin*, entered service in Y174.

Unfortunately, the small hulls proved incapable of the deep raids of full cruisers and only a few ships of the type were produced. The ships were used to chase down raiding cruisers in an effort to engage them until other forces could be gathered. They would often be held out of the fighting near a battle area, as they were under-gunned and there was no reason to risk them, but then be used to pursue fleeing enemy cripples.

The finished ship included the refits noted on the SSD, but as the ship might have been built at the same time as the NCL they are shown as separate items.

Known Ship Names: 1381 *San Martin*, 1382 *Simon Bolivar*, and 1383 *Pancho Villa*.

SSD and counter are in *Module R11*.

(R2.140) LIGHT ATTACK CARRIER (ADW): In Y174, the prototype of the F-111 (which had been on the drawing boards two years earlier) was flown. It was an impressive fighter, but at that juncture it proved to be one of the greatest design disasters (and perhaps public relations disasters) in the history of the Federation. The Federation Star Fleet had assumed that the designers were creating a fighter to operate from a carrier. The designers of the F-111 had assumed that Star Fleet was designing and would build a new carrier with a large enough shuttle bay to handle their new fighter (at least they would claim it to be so). Given the way the war was going at that time, there was very real fear that a foul-up of this magnitude might just be enough to tip the scales of public opinion to demanding peace at any price. (Most Federation citizens were not aware that Chairman Buckner had been trying to negotiate such a peace in Y173 in the incident that cost his life and the destruction of the *Hornet*.) Too many people were in the know about the F-111 (factories were

already tooling up for series production), so canceling the F-111 or even reducing “the buy” were not options.

In order to conceal the mess, Star Fleet commissioned this design as a “working concept”. It was based on the new DW design (the prototype of which had just finished its own trials). Faced with finding some means to build a shuttle bay for the F-111, the ship designers decided on the radical solution of building semi-external bays and presented it to the Admiralty board. It had never been done before, but the Admirals gave their approval.

The *Pulaski* was completed and entered service in Y176 as a prototype and *Pleasanton* and *Stewart* were ordered together a year later. To everyone’s amazement, the semi-external bays that had been hastily designed were literally a complete success. (Deck crews were not, however, too sure of that, since the bays required considerable additional safety equipment.) The F-111 itself proved to be a magnificent fighter worthy of larger deployment. The semi-external bay system was quickly refitted to many other classes (and was even used to operate some A-20s). Several other ships of the class were ordered, with *Lepidus* being the first of a sustained production of one per year. They operated as light scout carriers.

Known Ship Names: 1271 *Pulaski*, 1272 *Pleasanton*, 1273 *James Ewell Brown Stuart*, and 1274 *Marcus Aemilius Lepidus*.

Year	Escorts	Fighters
Y176-183	1xFFA	3xF-111
Y184+	1xDWA or FFA	3xF-111

This ship can control a number of seeking weapons equal to its sensor rating. Special sensors are destroyed on “torpedo” damage points.

SSD and counter are in *Module R11*.

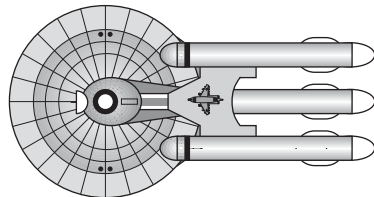

(R2.141) WAR DESTROYER ESCORT-R (DWR): A variant of the DWE intended for use on the Romulan border. As with most Romulan border escorts, the differentiation was found to be counter-productive and only a few were produced. After the first few ships, no more R-type escorts were built, and they were assigned interchangeably with standard escorts. While it was preferred to send DWRs to the Romulan border, carriers transferring from one sector to another did not exchange escorts. Any DWRs lost in combat were replaced by standard DWAs. The major difference was an increase in phasers for plasma defense and a reduction in type-G drone racks.

Known Ship Names: 0872 *President Gamal Abdel Nasser*, 0873 *President Gerald Ford*, 0874 *Prime Minister Indira Gandhi*, 0875 *Prime Minister Benazir Bhutto*, and 0876 *Senator Barry Goldwater*

This ship can control a number of seeking weapons equal to double its sensor rating.

SSD and counter are in *Module R11*.

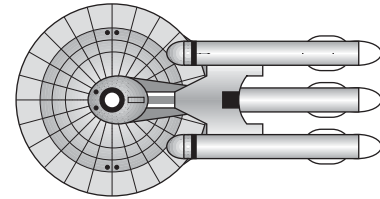

(R2.142) FEDERATION EXPRESS ESCORT (FXE): When the CVF *Gryphon* (R2.96) entered service in Y173, it was believed that her fast speed would enable her to avoid interception, negating the need for escorts when operating as a fast raider. Experience with raids in Y174 soon showed that the ship was vulnerable to attack by relatively weak defense forces while trying to recover fighters. Some consideration was given to construction of a DEF (an escort variant of the fast destroyer), but the problems with producing enough of the special engines to keep the existing fast cruisers and fast dreadnoughts operational made this unworkable. Diverting a fast new light cruiser to the job would have reduced the number of raiding ships available.

It was proposed that two Federation Express courier boats be converted to the mission. They were available in Y175, and included full aegis. The drone launch capability of the boats, it was thought, would be enough to hold an intercepting force at bay until *Gryphon* could recover her fighters. Two more boats, *Diemos* and *Phobos*, were built to serve as possible replacements, but were instead assigned to the DVL *Star Tiger*.

Due to the cramped crew conditions of the design, the ships did not normally operate with the *Gryphon* until it was sent on a raid. They were held nearby with their normal operating crews, and when the *Gryphon* was tasked with a raid, they would link up with her, drawing the rest of their needed crews from the *Gryphon*’s normal escorts. Once the raid was completed, the crewmen would re-deploy to their normal escorts. *Deimos* and *Phobos* operated in the same manner except that the operational crews (those in excess of the minimal crew needed to run an FX) were drawn from the crew of the *Star Tiger* itself.

The debate about whether or not to use the escorts continued through Y177, when it was made moot by the destruction of the *Gryphon* on one of her unescorted raids into Romulan space. The *Gryphon*’s FXEs were then reassigned to the *Star Tiger* as replacements in the event that some of her FXEs were lost.

These ships do not use (R2.R5), but carry the normal stores for an escort under (J4.621).

Known Ship Names: 1096 *Urim*, 1097 *Thumim*, 1098 *Deimos*, and 1099 *Phobos*.

This ship can control a number of seeking weapons equal to its sensor rating. This ship is nimble (C11.0).

SSD and counters are in *Module R11*.

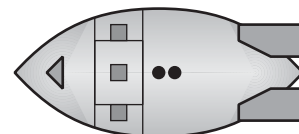

(R2.PF) FEDERATION FAST PATROL SHIPS

(R1.PF7) WORKBOAT: The Federation never built PFs. The SSD provided here is conjectural and itself based on the conjectural cargo version of the conjectural Federation Thunderbolt PF. While the Federation never built or deployed PFs, Federation corporations purchased numbers of workboats from neighboring empires. Most Federation workboats were purchased from the Gorns, although considerable numbers were also purchased from the Kzintis and the Orion Enclave (which provided most of the workboats that were used in the Federation capital systems). However, it was not unusual in the border regions to find Klingon (on the Klingon border) and Romulan (on the Romulan border) workboats in use (purchased after the General War). Some corporations even acquired workboats from Jindarian Caravans.

SSD is in *Module R11*. Use any PF counter.

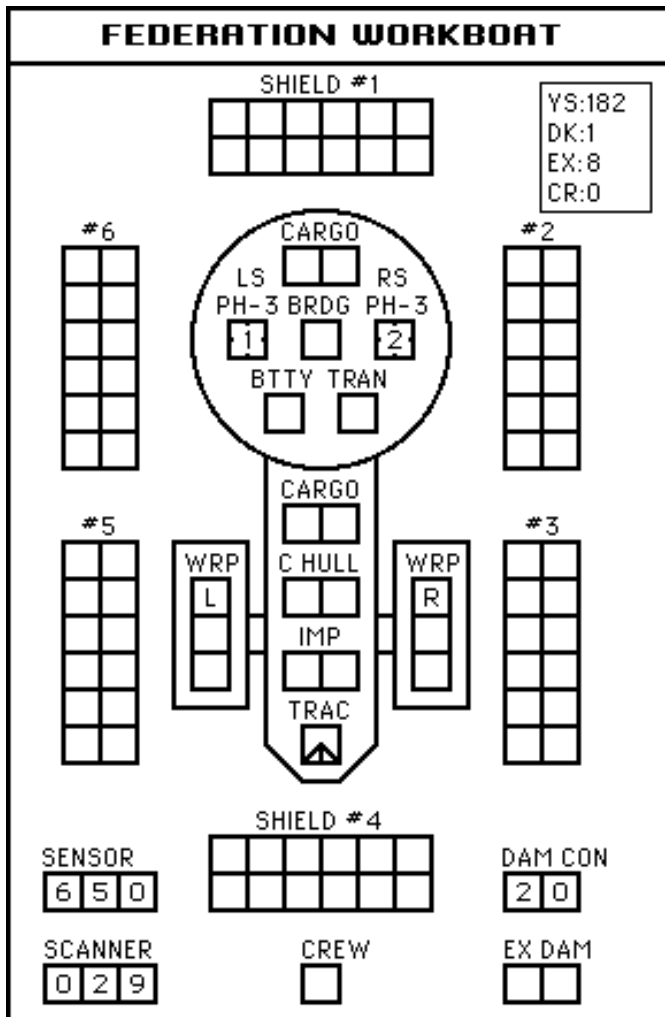

PERSPECTIVE: PATROL TENDERS

The class known as “patrol tenders” or “light PF tenders” (and by other names) is historically interesting. In some empires, it was the second-most-common type of gunboat tender; in others, it was only rarely used.

The reason that the “patrol tender” rises to the level of being noticed as a recognizable type is that it was one of the

first types of ships built to carry PFs, and was produced (in most empires) for the entire period of PF deployment. In both cases, this was because the war destroyer hull on which these ships were built was in common series production, having just taken over most of the frigate production slipways across the galaxy.

When interceptors first appeared in operational numbers, and planning for the subsequent gunboats (or PFs) had just begun, all empires that operated such craft began all sorts of experimental conversions of warships to carry them. At the time, no one knew what these new “very large attrition units” were going to amount to, and only the boldest of military thinkers predicted anything like the massive deployment of them that followed.

Most empires tried various means of “mobilizing” gunboats (that is, they converted various ship types into various PF tenders with from two to six gunboats). Many empires used obsolete hulls (such as the classic Kzinti destroyer), while others used mass production hulls (war destroyers and war cruisers), and almost all empires converted a few “one of a kind” ships from whatever damaged warships conveniently appeared in the repair yards.

Light PF tenders on war destroyer hulls were a common adaptation, used by virtually all empires. Most produced several similar (and a few radically different) designs before standardizing on a single model (the one shown as an SSD in this product). Many empires produced sub-variants of DW-based patrol tenders mounting two or four PFs before standardizing on three. Every empire that produced a light patrol tender designed one with an internal docking bay (which is why this product has standardized on that form). Players may wish to experiment with these patrol tenders by eliminating the internal bay and its mech link, or using the ships with two, three, or four PFs.

By the time PF deployment was well under way, most empires had standardized on one or two PFT types (usually, but not always, based on a war cruiser that was following a path blazed a year or two earlier by scout carriers), and the first space control ships and division control ships were moving from the drawing boards to the shipyards. But, except for the Gorns (who had selected their war destroyer as a primary source of PFT conversions) and those empires (i.e., the Federation) which had decided not to deploy PFs at all, every empire continued series production of light PF tenders on war destroyer hulls.

This was done for several reasons, but mostly because light patrol tenders did have a mission. In fact, they had no end of missions. They could be used to screen flanks, conduct combat reconnaissance, probe enemy lines, guard planets, escort convoys, or just about anything else that a war cruiser could do. (A patrol tender with three gunboats had at least the firepower of a light cruiser, and nearly the staying power. It was cheaper, and — sacrificing the gunboats — was more survivable.) Patrol tenders could do jobs that war cruisers normally did (and there were never enough of any type of ship for all the missions that wanted doing).

Patrol tenders are only one of several units that reflected a fundamental change in the way war was conducted after Y180. Fleet strength (in terms of ship count) increased steadily and at higher rates than ever before, not because of increased production (which had been at the maximum rate since Y175) but because of lower loss rates among ships. Losses were taken by attrition units (gunboats and heavy fighters) in far larger quantities than the earlier fighters could have ever absorbed. Interdiction carriers, patrol carriers, gunboat tenders, and division control ships, all reflected a steady trend against risking starships, and using attrition units to increase firepower and to absorb losses.

(R3.0) KLINGON EMPIRE

(R3.152) A5DW HEAVY ESCORT CRUISER (ADW): This is a carrier escort version of the D5W. While the Klingons used a variant of the D6 as a heavy escort for their first C8V, the bulk of their cruiser escorts were based on war cruisers, as was true for most races in the Alpha Octant. When the D5W entered service, plans were drawn up for an escort version. These were not realized, however, until Y180 when a badly damaged AD5, *Refuter*, was converted during repairs. The overall increase in firepower was marginal, but the heavier hull was better able to survive in combat while interposing itself between its carrier and harm's way.

Known Ship Names: *Refuter*, *Shieldwall*, *Firewall*, and *Stonewall*.

UIM: Not available.

This ship can control a number of seeking weapons equal to double its sensor rating.

SSD and counter are in *Module R11*.

(R3.153) E4S SCOUT: E4s had been introduced as the standard "frigate" in Y121, and were the most numerous ships in the Deep Space Fleet within a decade. When scout sensors became available in the mid-Y130s, it was the E4 which first carried them, and E4S scouts were the standard scouts until most of them were destroyed in the Four Powers War. The larger F5S had entered service in Y138, but remained exceptionally rare until many were hurried into production for the Four Powers War.

Known Ship Names: *Dauntless*, *Deceiver*, and *Scorn*.

UIM: Not available.

Special sensors are destroyed on "torpedo" damage points.

SSD and counter are in *Module R11*.

(R3.154) E4T TRANSPORT (E4T): In a break from the norm, the Klingon E4T is designed only to make cargo deliveries. Its ability to even defend itself is limited, relying as much as possible on speed and stealth (i.e., trying not to be noticed) to survive in dangerous areas. Note that the SSD provides the data for both single weight and double weight pods, but any pods carried by this ship are inactive and every box in such a pod is treated as a "cargo" damage point. The forward phasers cannot be fired in the rear arc if a pod is carried.

UIM: Not available.

Known Ship Names: *Governor Tarkin*, *Governor Termik*, and *Governor Kartt*.

SSD and counter are in *Module R11*.

(R3.155) F5T TRANSPORT (F5T): The F5T supplemented, but did not fully replace, the E4T until well into the General War. It appeared as a result of studies of losses of E4Ts during the retreat out of Hydran space in Y133. Note that the SSD provides the data for both single weight and double weight pods, but any pods carried by this ship are inactive and every box in such a pod is treated as a "cargo" damage point. The forward phasers cannot be fired in the rear arc if a pod is carried.

UIM: Not available.

Known Ship Names: *Chancellor Tokak*, *Chancellor Kretos*, and *Chancellor Krevetk*.

SSD and counter are in *Module R11*.

(R3.156) UD7 DIVISION CONTROL SHIP (UD7): This ship used the double-stacked shuttle bay seen in the D7V, and carried the PFs on mech links (two on the boom, four on the rear hull). The rear hull has a four-space balcony (J1.53)

adjacent to the lower bay and an elevator system (R3.R6) connects the upper and lower bays. PFs can only be repaired on the four mech links in the rear hull using collapsible repair bays (K2.63).

Year	Escorts	Fighters
Y179-180	1xAD5, 1xFWE or AF5	12xZ-Y
Y180-183	1xAD5, 1xFWE or AF5	12xZ-YB
Y183+	1xAD5, 1xFWE or AF5	12xZ-YC

Known Ship Names: *Ironmaster*, *Devilmaster*, and *Deathmaster*.

UIM: Not available.

This ship can control a number of seeking weapons equal to double its sensor rating. Special sensors are destroyed on "phaser" damage points.

SSD and counter are in *Module R11*.

(R3.157) F5WP LIGHT PF TENDER (FWP): When the Klingons received interceptor technology from the Lyrans, they, in common with most other races, were unsure how the new combat units would be used. The boats were clearly too large to be operated from a normal shuttle bay, and no ship could be made large enough to operate more than two or three internally without so drastically weakening the frame that the ship would be in constant danger of breaking up. Not wanting to waste a larger hull, the Klingons commissioned the Kupatnik Design Bureau to design and construct a ship to see if deploying the new units operationally was feasible. The Kupatnik Design Bureau examined reports on a Lyran DWP that had visited the Klingon homeworld while escorting a convoy, and used that as their design inspiration. Like the Lyran DWP, they solved the operational problems by gutting many of the systems in the secondary hull in order to install a large bay capable of accommodating a single interceptor. It was only in this bay that an interceptor could be repaired, have its warp packs replaced, have its warp engines flushed of the ionization buildup, and have its drone racks reloaded. The interceptors themselves would be carried on external mechanical linkages.

By the time the ship entered service, the Lyrans had already developed the means to flush the engines of a PF at any station, and had developed external repair capabilities and warp pack replacement systems (they were also already operating prototypes of the Bobcat PF). The FWP entered service with all of its many handicaps, operating what would eventually be called a half-squadron of interceptors.

Surprisingly, the ship was found effective as a convoy escort, and more were built, eventually operating the new G1 PF. By Y179, all FWP's were able to de-ionize the warp engines of docked PFs at their normal docking stations, but retrofitting the ships with collapsible repair bays was not possible. The ships were, however, found capable of "special operations" carrying a fourth PF in their internal bays.

Known Ship Names: *Blood Chaser*, *Death Chaser*, *Doom Chaser*, *Dragon Chaser*, *Fire Chaser*, and *Storm Chaser*.

UIM: Not available.

Special sensor is destroyed on "torpedo" damage points.

SSD and counter are in *Module R11*.

(R3.158) FD5 FAST WAR CRUISER (FD5): By late Y174, the Klingons realized that the war would be longer than they had at first thought (particularly after the heady advances they had made in the earlier stage of the conflict). Attempts to negotiate cease-fires with the Federation (in Y173) and Kzintis (in Y174) had both gone nowhere, and the Hydrans,

while contained, were a nagging presence. Worse, the Gorn Confederation's entry into the war had greatly curtailed the offensive capability of the Romulans, freeing the Federation to deploy more of its forces against the Klingons.

Seeking to avoid being pushed over to the strategic defensive, the Klingons determined to make more raids into the rear areas of the Alliance forces. To that end, they brushed off an earlier design for a fast war cruiser and produced the first such ship in Y175. (It had first been designed in Y170.) The first ship in the class included the Y175 refit, but not the "K" refit. Records are unclear as to just when (or even if) the first ship ever got the "K" refit. The other ships in the class included both refits. Like the fast war cruisers of other races, the FD5 proved to be too limited to raid effectively behind enemy lines and operated mostly as a "fire brigade", rushing to the relief of beleaguered convoys and colonies in the rear of the forward battle area. Like other such ships, it was also used to intercept raiding cruisers, and to pursue retreating cripples.

Known Ship Names: *Nightraider*, *Starraider*, *Stormraider*, *Sunraider*, and *Thunderraider*. There were more built.

UIM: One standard.

Limited aegis system controls waist phaser-3s and ADDs.

SSD and counter are in *Module R11*.

(R3.159) P-M11 MEDIUM HANGAR PODS (P-M11): The pre-war pods with only five fighters were designed during the period when fighter concepts were still evolving, and were based on an earlier pod that was used to carry assault shuttles to support Klingon Marines. Once the Klingons determined how fighters would actually operate, they converted their original hangar pods to operate six fighters and built additional pods of this improved type.

Each pod can control a number of seeking weapons equal to half the sensor rating of the tug to which it is attached. This control ability is added to the tug's control ability.

UIM: Not available.

SSD is in *Module R11*. Use any pod counter.

(R3.160) P-H12 HEAVY FIGHTER RESUPPLY PODS (P-H12): When advanced heavy fighters went into widespread service, the Klingons noted that they could not be carried in the existing FCRs and used these special pods to transport replacement heavy fighters to those carriers that operated them. These pods can carry fighters but cannot operate, land, refuel, or rearm them. The one shuttle bay was used to "warm up" replacement fighters, which could only launch once, and could not land. The bay did have ready racks and could fully arm the fighters before sending them on the way to their carriers (these are marked "H" for heavy fighter). This type of pod can carry standard fighters (under the same restrictions) but cannot arm them via ready racks as the racks are for heavy fighters; they will have to use (J4.8962) and (J4.892). The shuttle bay includes an HTS to facilitate cargo transfer.

UIM: Not available.

SSD is in *Module R11*. Use any pod counter.

(R3.161) P-PT13 FAST PATROL SHIP TRANSPORT PODS (P-PT13): These were used to carry replacement PFs and crews to front-line PF tenders. Each pod could carry six PFs, but could not operate, repair, refuel, or rearm them. Once the PFs were launched, they had to transfer to a regular PFT for operations. Note the special version of a PF mech link symbol indicating that this limited type cannot dock a PF outside of a supply facility. PFs launched from these pods will only have one crew unit and cannot carry more until they are serviced

by a true PFT by having one repair point allocated to them by the PFT's repair systems.

UIM: Not available.

SSD is in *Module R11*. Use any pod counter.

(R3.PF) KLINGON EMPIRE FAST PATROL SHIPS

(R1.PF7) U1 WORKBOAT: After PFs had been in service a while, the Klingons began producing this variant of the cargo PF to supplement (and in many cases replace) skiffs. The workboat was cheaper to operate than the skiff and required far less maintenance (although skiffs remained in use). When the General War ended, Klingon factories continued producing this class of PF even as they (temporarily) curtailed production of combat variants because there was a huge need for them (and a huge market right next door in the Federation which did not produce its own PFs). Local shortages (and corruption which led to promised deliveries of workboats being diverted to the more lucrative Federation market) led to many local Klingon governments purchasing workboats from whatever source was at hand. It was thus not unusual in the border regions to find workboats from other races being operated by Klingon subjects. Some of those eventually made their way (through a number of trades and being bought by different partners) well into the core regions of the Empire (e.g., a Hydran workboat operating in the Klinshai system). Workboats were a constant nightmare to the Empire Security Service (ESS), as there were too many of them to place an ESS agent on every one, and their crews were too small, and of necessity tightly knit, for an outsider to burrow his way in to investigate their "loyalty". In the border regions, there was no doubt that workboats were being used to move foreign agents into the Empire. (Of course, the reason there was no doubt was that the Empire's various intelligence agencies were using workboats that way themselves.) Still, the ESS did its best to try to make the crews of workboats think that it was omnipresent (and failed miserably in doing so). The ESS eventually established an internal border beyond which any workboat that did not have a special permit was subject to immediate seizure.

SSD is in *Module R11*. Use any PF counter.

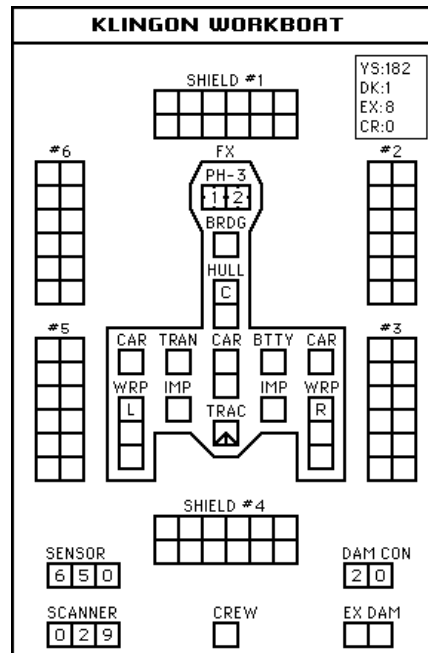

(R4.0) ROMULAN STAR EMPIRE

(R4.127) SUPERHAWK-U DIVISION CONTROL SHIP (SUU):

The Romulan entry into the division control ship concept was late, driven in part by the economic disruption the Empire had suffered. With the losses their fleet had suffered, the Romulans found themselves regretting their earlier decision not to use more fighters, and increasingly sought to mount fighters and PFs on as many hulls as possible in an effort to preserve what remained of their fleet. Altering the Superhawk’s design to create the SUU proved to be a difficult task. Once the design was in place, making the extensive modifications to the ship was time-consuming and difficult. These elements may have contributed to the delay in the ship’s appearance. The first ship in the class was sent to the ISC frontier as that area was becoming more active (as the ISC prepared for the Pacification Campaign). Their most extensive employment was in the role of hunting down Andromedan RTN nodes, but being relatively under-armed they were hard pressed to survive finding one.

Year	Escorts	Fighters
Y183+	SPM, 2xSKEA	6xG-III-K, 6xG-D

Known Ship Names: *Consul Decimus, Consul Valerius, and Solium Principatus.*

Each module carries three superiority fighters, and three torpedo fighters, no transfers between bays are possible.

Special sensors are destroyed on “torpedo” damage points.

SSD and counter are in *Module R11.*

(R4.128) FARHAWK-K HEAVY CRUISER (FAK): The Romulans never built any ships of the Farhawk design. The SSD shown here portrays the basic Farhawk in the heavy cruiser configuration. In this role, it would be comparable to a Hydran hybrid ship, and that was the principle reason the Romulans did not proceed with the design. The Romulan Fleet Command determined that, while fighters are considerably cheaper than warships, the logistical network that would be needed to replace fighter losses on a fleet of hybrid ships was just more than the Empire could handle. It was also questionable whether or not it would be able to re-arm the plasma-F freezers of its Gladiator-I, -II, or -III fighters while engaged in close combat, pretty much relegating such fighters to being armed with plasma-Ks and operating as drone defense fighters. A duel with such a ship would, however, be every captain’s nightmare. As a cruiser, it would not have used any escorts and would likely have used the best fighters available.

It is possible that this ship might operate a squadron of Tribune Heavy Fighters, or that mega-fighter packs might be installed.

Year	Escorts	Fighters
171-173	None	6xG-I, 6xG-F
Y173-180	None	6xG-II, 6xG-SF
Y180-183	None	6xG-III, 6xG-FSF
Y183+	None	6xG-III-K, 6xG-D

Known Ship Names: None.

SSD and counter are in *Module R11.*

(R4.129) FARHAWK-B HEAVY CARRIER (FAB): Assuming the Romulans had gone ahead with the Farhawk design instead of the Firehawk, they would have had the option of mounting the B-Modules of the Sparrowhawk-B carrier to the

base hull. The resulting ship would have had 28 fighters, and would probably have operated them as three squadrons (although the composition of the squadrons could have changed depending on the mission). The escorts would probably have been identical to that used by the Superhawk-B since the loss of firepower to use the B-Modules is the same, including the inability to fast load both plasma-S torpedoes as plasma-Fs. The design is an obvious interim stepping-stone from the Farhawk-K heavy cruiser to a Farhawk-U area control ship.

Year	Escorts	Fighters
Y173-175	SPA, 2xSKE	14xG-II, 14xG-SF
Y175-180	SPM, 2xSKEA	14xG-II, 14xG-SF
Y180-183	SPM, 2xSKEA	14xG-III, 14xG-FSF
Y183+	SPM, 2xSKEA	14xG-III-K, 14xG-D

Known Ship Names: None.

There are four bays, no transfers. Each module holds four superiority fighters, and four torpedo fighters; the center bays hold six superiority fighters and six torpedo fighters. No transfers between bays are possible.

SSD and counter are in *Module R11.*

(R4.130) FIREHAWK-M HEAVY ESCORT CRUISER (FHM):

Romulan carrier group commanders were much impressed with the performance of the Klingon AD6, and long sought to convince the Romulan Admiralty that such large escorts should be provided for their own heavy carriers. The Admiralty saw the use of a large hull as a carrier escort as a waste, judging the existing Sparrowhawk-Ms as more than sufficient for the task. In Y177, the politically weakening Praetor Maxillius resolved a deadlock in the Imperial Senate created by the antagonism between House Aurelius and House Notrub’illah. He did so when he agreed to allow the construction of such ships to gain Notrub’illah’s acquiescence in ending the deadlock. The first ship entered service the next year, and two or three more may have been built or converted before the General War ended, but the records are unclear. The ship included full aegis.

Known Ship Names: *Caetra, Consul Regulus, and Loyal Guard.*

SSD and counter are in *Module R11.*

(R4.131) KD5RS WAR CRUISER SCOUT (KDS):

The Romulan Star Empire acquired three Klingon D5 war cruisers in Y174. The ships were unique in the Romulan fleet in that no other ship class, other than the KRT tugs, was acquired in such a low number. There were really no other ships in the fleet (not even conversions of other Klingon ships) that were able to mesh well with the operational characteristics of the ships. During the course of their service, the Romulans developed many plans to convert the three ships into something where their operational uniqueness would be less of a burden. Serious consideration (and a complete design study) put into converting the ships into scouts. The study indicated that the ships would still have had operational problems working with other Romulan units (due to differences in cloaking operations) but would otherwise have been effective in the role. The conversion was not undertaken, however, because of fears that the unique engines of the ships would create maintenance problems that would result in their not being available. It remains a case of “what might have been” had the Federation not reached Tholian space and cut the flow of spare parts from the Klingon Empire to the Romulans.

Known Ship Names: Would probably have retained the name of the ship converted.

Special sensors are destroyed on “torpedo” damage points.

SSD and counter are in *Module R11*.

(R4.132) SCREECH OWL HEAVY SCOUT (HSE): This design was intended to increase the effectiveness of the Scout Eagle by installing part of the King Eagle upgrade. While the resulting ship was fast and better able to support combat operations with four sensors and a fair amount of power, the Romulans decided not go ahead with series production, preferring to continue the more flexible modular designs of their third generation ships.

At least one ship was built (as a prototype) and was assigned to operate in the Romulan exploration zone looking for resources for the war effort. It was reportedly destroyed by ISC forces in Y186.

Known Ship Names: *Vox Mortis*.

This ship has one nuclear space mine included in its BPV (M2.72).

Special sensors are destroyed on “torpedo” damage points.

This ship can land on planets using the aerodynamic landing system (P2.433).

SSD and counter are in *Module R11*.

(R4.133) SEAHAWK-H TRANSPORT FRIGATE (SHH): The Romulans, like other empires, found themselves in need a small transport able to move pods. This task was being handled by a Snipe variant that was able to move Freight Eagle pallets, but the Romulans had initially assumed that there would be no need to move other “pods”. As the war progressed, they found that the Skyhawks were needed at the front, and not as available for the transport mission as had first been believed. Of course, the reason for this was the unexpected entry of the Gorns into the General War, which had required more logistical effort than had been in the pre-war plans. By Y176, the problem had become acute because far more Sparrowhawk modules were being redeployed than had been imagined. It was not possible to further increase the numbers of Skyhawks that could be diverted to the task, or to acquire more Klingon tugs, and Freight Eagles had other tasks to perform. So the choice fell to the Seahawk, a ship only barely able to perform the job. Seahawks continued to be built for the task well into the Andromedan War. They were able to carry one Klingon cargo pod, or two Sparrowhawk or two Skyhawk modules (each pair of modules counts as one “pod”). It could not carry a Skyhawk and a Sparrowhawk module at the same time due to dynamic balance problems. Note that the Romulans did not have any double weight pods historically, but the SSD provides the data if such a pod is captured. Any pods or modules carried by this ship are inactive and every box in such pods or modules is treated as a “cargo” damage point.

Known Ship Names: These were given hull numbers, not names.

SSD and counter are in *Module R11*.

(R4.134) FAST SPARROWHAWK-A LIGHT CRUISER (FSP): As with other races, the Romulans designed a raider version of their war cruiser as part of its initial design, but did not initially build one. Like the Klingons, the Romulans saw the need for more raiders when the war began to turn against them. Unlike other races, however, the unusual status of the Sparrowhawk as something more than a true war cruiser made it an effective raider. Partly this was due to the design, and partly it was due to the inherent nature of the cloaking device which made the ship better able to avoid detection rather than having to be ready for constant battles. The original design did not include the plus refit, but it was

included in the first ship of the class and all subsequent production.

Known Ship Names: *Blaze*, *Death Talon*, and *Proconsul Crosus*.

SSD and counter are in *Module R11*.

(R4.PF) ROMULAN EMPIRE FAST PATROL SHIPS

(R1.PF7) PLEBIAN WORKBOAT (PLB): After PFs had been in service a while, the Romulans began producing this variant of the cargo PF to supplement (and in many cases replace) skiffs. The workboat was cheaper to operate than the skiff and required far less maintenance (although skiffs remained in use for years). When the General War ended, Romulan factories continued producing this class of PF, although production rates remained low as combat PFs were needed to support the Romulan Civil War (by both sides), and later to try to fend off ISC and the Andromedan incursions. Corruption within the Romulan Great Houses, along with the chaos of the Empire’s collapse and then democratic revival enabled Federation and Gorn (and even ISC) corporations to purchase numbers of these boats. Some Romulan Houses, unable to acquire workboats from their own economy, purchased Klingon, Gorn, ISC, and even Orion workboats rather than be at an economic disadvantage to other Houses.

SSD is in *Module R11*. Use any PF counter.

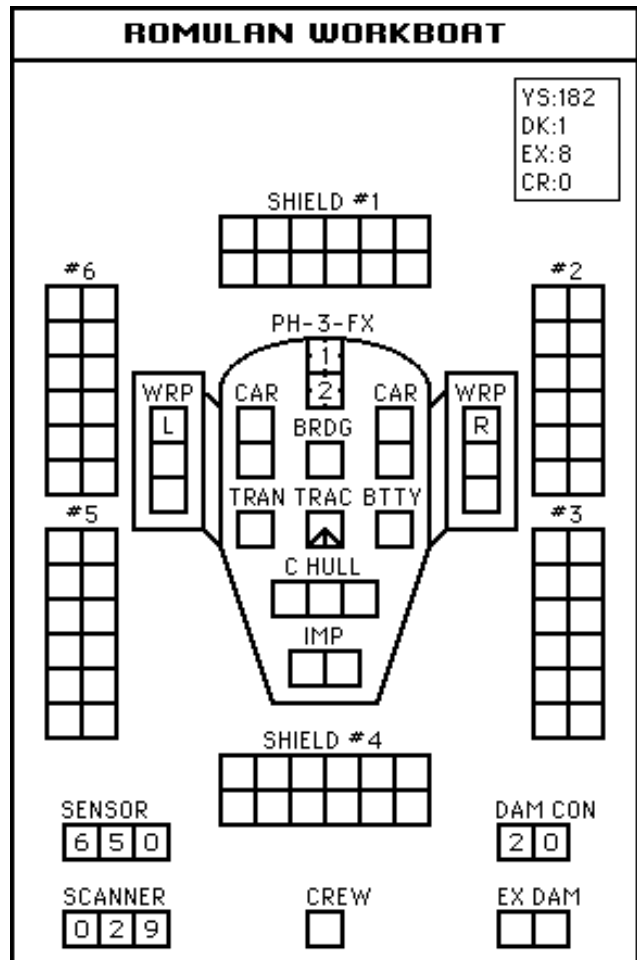

(R5.0) KZINTI HEGEMONY

(R5.106) DIVISION CONTROL SHIP (DCS): Built on the hull of a command cruiser, this ship was originally used to carry heavy fighters and then interceptors on its mech links, something no other division control ship did. This reflects the slowness of the Kzintis to move to the PF concept. When operating heavy fighters, the mech links are treated as semi-external fighter mech links as seen on the Federation DCS in this product, and were actually copied from those in Federation service. There is no change in the BPV of the ship to do this, but 12 deck crews are added to the ship's crew. These extra deck crews are deleted when the ship is upgraded to PF mech links (these deck crews were converted into repair technicians to operate the ship's repair systems). When the ship operated heavy fighters the four repair boxes were cargo boxes containing two spare heavy fighters and four spare single-space fighters, these are in addition to the one spare shuttle and two spare fighters the converted ship carries. The conversion to interceptors replaces the four cargo boxes with repair boxes and converts the heavy fighter mech links to PF mech links operating interceptors and later PFs.

The bay has a forward hatch on the face of the lower hull and a rear hatch on the belly. Shuttles can launch from or land at either hatch [tunnel deck (J1.58)], but the normal procedure is to launch from the forward hatch and land in the rear one.

Year	Escorts	Fighters
178-179	MAC, DWA or AFF	6xLFS, 12xTAAS
Y179-180	MAC, DWA or AFF	6xINT, 12xTAAS
Y180-181	MAC, DWA	6xINT, 12xTADS
Y181-183	MAC, DWA	6xPF, 12xTADS
Y183+	MAC, DWA	6xPF, 12xTADSC

Names: *Starblade, Novablade.*

This ship can control a number of seeking weapons equal to double its sensor rating.

Special sensors are destroyed on "phaser" damage points.

SSD and counter are in *Module R11*.

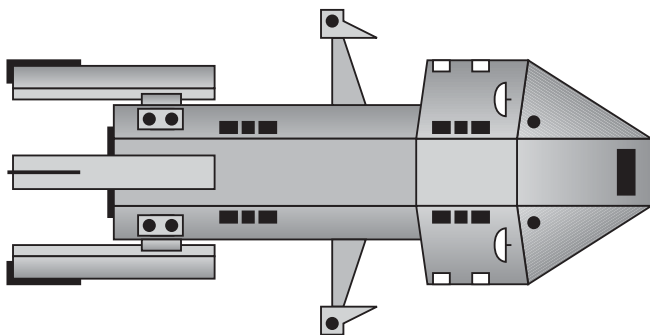

(R5.107) TRANSPORT FRIGATE (FFT): The Kzinti FFT was actually designed to remain in a combat zone to keep other ships supplied with drones. Its own drone capabilities made it an effective combatant when not hobbled by a pod. Note that the SSD provides the data for both single weight and double weight pods, but any pods carried by this ship are inactive and every box in such a pod is treated as a "cargo" damage point.

Known Ship Names: As with all Kzinti frigates, these ships were simply assigned hull numbers and not named. SSD and counter are in *Module R11*.

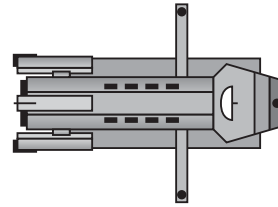

(R5.108) LIGHT PF TENDER (DWP): The Kzintis were somewhat slower than their enemies to move into fast patrol ships. The reason for this has never been made clear, although political machinations seem likely. Many suggest it was just the difficulty of changing their already war-ravaged economy to a new paradigm. As with most races, their first foray into using the PF prototype (interceptors) involved the conversion of a war destroyer. The Kzinti DWP was perhaps the best armed of the type, retaining half of its drone racks. It was perhaps the best "special mission" ship of the breed. Almost uniquely among the empires, the Kzintis decided (based on their experience with this ship) that internal bays were the way to go, and incorporated them into more designs than any other empire.

Known Ship Names: *Three Claws, Three Winds, and Three Teeth.*

This ship can control a number of seeking weapons equal to its sensor rating.

Special sensor is destroyed on "torpedo" damage points. SSD and counter are in *Module R11*.

(R5.109) FAST MEDIUM CRUISER (CMF): Yet another in the class of fast war cruisers, Kzinti CMF, like the larger BF, made up for the paucity of drone launchers (the paucity forced by the engine stress) with deep magazines on the drone racks it did possess. The ship normally carried mostly type-IV drones, although some type-Is were present simply to help confuse an opponent's ability to track its ammunition expenditure. Like most fast war cruisers, it was found too limited to use on deep raids and spent the majority of its time in reserve outside the battle area, waiting for a crippled ship to be identified as a target for assassination. The cargo box on this ship holds 50 spaces of reload drones for its drone racks. Drones in this cargo box will be proportional to those loaded in the drone racks (FD2.45).

Known Ship Names: *Deathsong and Deathclaws.*

This ship can control a number of seeking weapons equal to double its sensor rating.

SSD and counter are in *Module R11*.

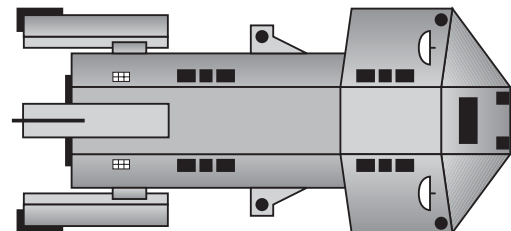

(R5.110) SCOUT POD (P-S10): The Kzintis, like the Hydrans, did not expect combat electronic warfare to be a major element of fleet battles. They provided scout pods so tugs could, in an emergency, provide sector scans and fleet warning. When the Klingons and Lyrans invaded with seriously superior scouts, the Kzintis had to use their scout pods in combat to minimize the EW deficit. It was this use that

may have been the principle cause of tugs being lost in combat during the early years of the General War.

Special sensors are destroyed on "phaser" damage points.

SSD is in *Module R11*. Use any pod counter.

(R5.111) HEAVY FIGHTER RESUPPLY POD (P-F11): This pod was used to carry replacement heavy fighters to the CVH and MVH carriers that used them, since standard FCRs could not provide resupply of these larger fighters. These pods can carry fighters but cannot operate, land, refuel, or rearm them. The one shuttle bay was used to "warm up" replacement fighters, which could only launch once, and could not land. The bay did have ready racks (marked "H") for LAS fighters, and could fully arm such fighters before sending them on the way to their carriers. This type of pod can carry standard fighters (under the same restrictions) but cannot arm them via ready racks as the racks are for heavy fighters; they will have to use (J4.8962). The shuttle bay includes an HTS to facilitate cargo transfer.

SSD is in *Module R11*. Use any pod counter.

(R5.112) PF TRANSPORT POD (P-PF12): These carried twice as many PFs as standard PFT pods, but at a cost. Each pod could carry six PFs, but could not operate, repair, refuel, or rearm them. Once the PFs were launched, they had to transfer to a regular PFT to begin operations. These pods were a vital link in the logistical chain that maintained fleet frontline strength. PFs launched from these pods will only have one crew unit and cannot carry more until they are serviced by a true PFT by having one repair point allocated to them by the PFT's repair systems.

SSD is in *Module R11*. Use any pod counter.

(R5.113) WAR DESTROYER TRANSPORT (DWT): The Hegemony determined that a heavier transport was needed to move pods to the forward combat area. Several ships of this class were produced during the final years of General War. During the subsequent ISC Pacification and Andromedan Wars, this class completely replaced the FFT in production, but even as late as Y199 one or two FFTs were still in operation. Note that the SSD provides the data for both single weight and double weight pods, but any pods carried by this ship are inactive and every box in such a pod is treated as a "cargo" damage point.

Known Ship Names: None.

SSD and counter are in *Module R11*.

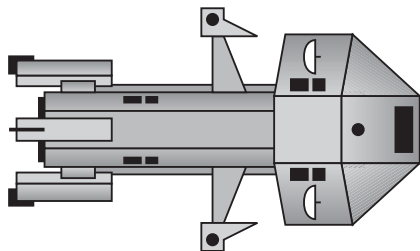

(R5.PF) KZINTI HEGEMONY FAST PATROL SHIPS

(R1.PF7) WORKBOAT: After PFs had been in service a while, the Kzintis began producing this variant of the cargo PF to supplement (and in many cases replace) skiffs. The workboat was cheaper to operate than the skiff and required far less maintenance (although skiffs remained in use). When the General War ended, Kzinti factories continued producing this class of PF even as they (temporarily) curtailed production of combat variants because there was a huge

need for them (and a huge market right next door in the Federation which did not produce its own PFs). Local shortages (and disruption caused by "The Return of the Usurper") led to many local Kzintis corporations purchasing workboats from whatever source was at hand. It was thus not unusual in the border regions to find workboats from other races (Lyran, Klingon, Orion, WYN, and even Jindarian) being operated by Kzintis. Workboats were a constant nightmare to Whiskers (Kzinti Intelligence), as there were too many of them to watch, and their crews were too small, and of necessity tightly knit, for an outsider to burrow his way in to investigate their "loyalty". Agents of the Usurper were known to use workboats to work their way into the confines of secure areas of the Hegemony. (Whiskers knew this because it was using workboats to place agents in space over run by the Usurper's forces.)

SSD is in *Module R11*. Use any PF counter.

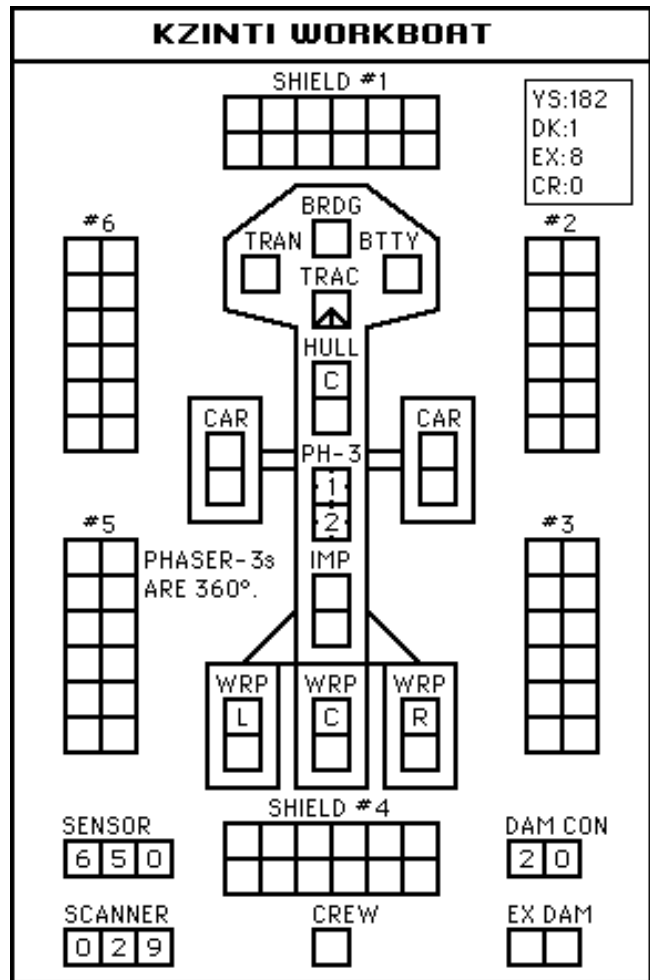

(R6.0) CONFEDERATION OF THE GORN

(R6.93) DIVISION CONTROL SHIP (DCS): Unlike the division control ships of other empires, the Gorn division control ship was not based on their command cruiser, but on a slightly stretched and heavily modified strike carrier. The first ship in the class, *Sawtooth*, entered service in Y184, and at least one more ship was built, but it is unclear if there were any more ships in the class. The complete lack of inherent plasma torpedoes (forced on the design due to space considerations that even the slight stretching of the CVS hull could not solve) left it as one of the weakest ships of the type. This ship's shuttle bay is a tunnel deck (J1.58), a single bay with hatches on both sides of the ship. Shuttles can launch from or land at either hatch.

Year	Escorts	Fighters
Y184+	HDA, BDA	12xG-12D

Known Ship Names: *Sawtooth* and *Lizard King*.
 Special sensors are destroyed on "torpedo" damage points.
 Federation Reporting Name: *Maiasaura*.
 Balcony Positions: Three left and three right.
 SSD and counter are in *Module R11*.

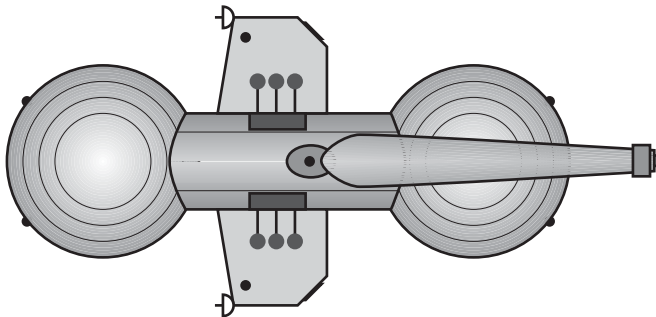

(R6.94) DESTROYER TRANSPORT (DDT): While not originally intended to be a combatant, the fact that the design included additions that would later be incorporated into the DDF upgrade (like the plasma-F torpedoes in the wings) left it able to hold its own against small Romulan or Orion raiders. This was fortunate, as the Confederation could not upgrade DDTs to BDTs, and the DDT design had to soldier on until well into the next century. Note that an aspect of warp dynamics gave this ship a boost over smaller mini-tugs when hauling pods, i.e., the movement cost is only 0.75 with a pod, and 1.0 with a double weight pod. The SSD provides the data for both single weight and double weight pods, but any pods carried by this ship are inactive and every box in such a pod is treated as a "cargo" damage point.

Known Ship Names: *Heavy Hands* and *Littlefoot*.
 Federation Reporting Name: *Parasaurolophus*.
 Balcony Positions: Two left and two right.
 SSD and counter are in *Module R11*.

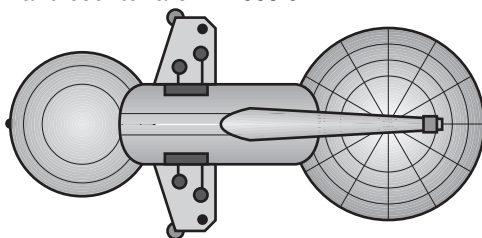

(R6.95) LIGHT PF TENDER (PTD): From reports given to the Gorns by Federation Intelligence (plus a smaller number provided by Whiskers, Kzinti Intelligence) and gathered by their own military attaches, the Confederation fleet was aware that the Lyrans and Klingons were operating small attack boats carried by ships. There was little doubt that this technology would eventually be given to the Romulans. The Confederation designed its own attack boats, partly to develop tactics to counter them, and partly with an eye to fielding them. Their small cost and comparatively large combat power would doubtless appeal to the ever parsimonious Confederation Legislature (where there was much rumbling about the costs of the war and frequent calls to simply negotiate a peace). By Y177, the Gorns had the basic concepts, but like the other empires, were not sure how to operate the units. Repairing them obviously required a docking bay (reports of Lyran and Klingon ships making repairs to the attack boats were sketchy at best). To facilitate repairs, the Confederation designed (and built) a variation of the battle destroyer with a large hatch on the top of the ship just behind the shuttle bays so that a boat could be taken inside for repairs. The ship entered service in Y178, about two weeks after the Confederation learned of the collapsible repair bays the Lyrans and Klingons had developed. At least two more ships of the class were built while the Confederation figured out how to install such bays on their own ships.

Like all light PF tenders, the ship was not able to replace warp packs on PFs docked outside of the repair bay, and could not initially de-ionize the engines of interceptors on its normal docking points (this problem was fixed by the time PFs were available). The inability to reload plasma-D racks outside of the internal bay made PFs armed with them less effective, so only other PF types were used.

Known Ship Names: *Three Claws* and *Triple Strike*.
 Special sensor is destroyed on "torpedo" damage points.
 Federation Reporting Name: *Sinosauropteryx*.
 Balcony Positions: Two left and two right.
 SSD and counter are in *Module R11*.

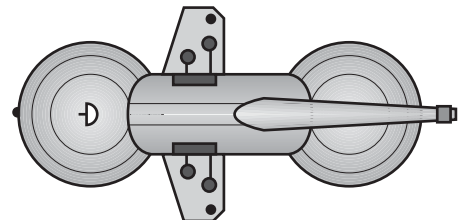

(R6.96) FAST HEAVY DESTROYER (HDF): The Confederation, unlike most empires, did not design a fast version of their war cruiser prior to entering the General War. The Confederation Admiralty was convinced that the use of such ships, given the nearness of the Romulan capital systems to Confederation space, would be limited. Studying the operations of the other empires involved in the General War resulted in a change in thinking, and by Y172, the first HDF was under construction as raids by squadrons seemed like a viable military option. Unfortunately, the original design of the HDD had been kept as small as possible (in order to get appropriations for it through the Senate by convincing them it was a "destroyer"), and this resulted in a fast war cruiser that had the shortest operational range of any of the raiders. The ship was used in much the same ways as the fast war cruisers employed by other empires.

Known Ship Names: *Egg Snatcher* and *Redscales*.
 Federation Reporting Name: *Kentrosaurus*.
 Balcony Positions: Two left and two right.
 SSD and counter are in *Module R11*.

(R6.97) SCOUT POD (P-SC): A rarely-used pre-war pod which could turn a tug or LTT into a viable fleet scout. Records are unclear if this pod was built at the request of the Confederation Navy, or if the Gorn Senate forced the Navy to purchase the pods and not build large scouts (R6.10). It is possible that the purchase of these pods delayed the acquisition of large scouts by half a decade. Fortunately, the Romulans chose to attack the Federation, giving the Confederation the time it needed to build larger electronic warfare platforms to support the fleet's operations.

Special sensors are destroyed on "phaser" damage points.

Federation Reporting Name: *Dinosaur Egg-SC*.
Balcony Positions: None.
SSD is in *Module R11*. Use any pod counter.

(R6.98) HEAVY FIGHTER RESUPPLY POD (P-HF): Used to provide replacement fighters for those carriers that operated these special types. These pods can carry fighters but cannot operate, land, refuel, or rearm them. The one shuttle bay was used to "warm up" replacement fighters, which could only launch once, and could not land. The bay did have ready racks (marked as "H") and could fully arm the fighters before sending them on the way to their carriers. This type of pod can carry standard fighters (under the same restrictions) but cannot arm them via ready racks as the racks are for heavy fighters; they will have to use (J4.8963) and (J4.892). The shuttle bay includes an HTS to facilitate cargo transfer.

Federation Reporting Name: *Dinosaur Egg-HF*.
Balcony Positions: None.
SSD is in *Module R11*. Use any pod counter.

(R6.99) PF TRANSPORT POD (P-TP): This pod was able to carry two full flotillas of PFs, but could not operate them and could only launch them one time. Each pod could carry twelve PFs, but could not repair, refuel, or rearm them. Once the PFs were launched, they had to transfer to a regular PFT to start operations. It was used to keep true PFTs on the front line at full strength, allowing sustained offensives. PFs launched from these pods will only have one crew unit and cannot carry more until they are serviced by a true PFT by having one repair point allocated to them by the PFT's repair systems.

Federation Reporting Name: *Dinosaur Egg-TP*.
Balcony Positions: None.
SSD is in *Module R11*. Use any pod counter.

(R6.100) LOCAL DEFENSE SCOUT CRUISER (LCS): This class was authorized in the Confederation Legislature as a "survey cruiser" to supplement the SRs in the exploration zone of the Confederation. Some of the ships actually did some exploration, but none are known to have joined the Sixth Fleet. Their principle employment was as additional protection around planets that had particularly powerful Representatives. Such deployments did not prevent some of the ships being involved (and sometimes lost) in combat. Romulan raiders, Orion Pirates, ISC incursions, and Andromedans striking from their RTN all created opportunities for the crews of these ships to earn their battle honors.

Known Ship Names: *Gralkatin* (the first Gorn astronaut).
Special sensors are destroyed on "torpedo" damage points.

Federation Reporting Name: *Herrerasaurus*.
Balcony Positions: None.
SSD and counter are in *Module R11*.

(R6.PF) GORN CONFEDERATION FAST PATROL SHIPS

(R1.PF7) WORKBOAT: The Confederation began building workboats at the same time as it built combat PFs. The obvious value of the boats (cheaper) in replacing many skiff operations appealed to the Confederation Legislature. This was despite the pleas by the Confederation Navy at the time, that such a diversion might add years to the war when every combat PF would be needed at the front. This argument was dismissed by the Legislature, which noted that, as the Confederation had only just deployed PFs, their overall impact could not be calculated. It should be noted that only a few very junior members of the Legislature ever traveled on a workboat (other than as a political stunt). If they needed to travel any distance, most used the older skiffs. As it was, the war did not last many years longer, and by its end the Confederation's workboat design was widely proliferated through its space, and large numbers had been sold to the Federation. (There are records that the Kzinti Hegemony purchased some during the period of the Usurper's "return".) The Confederation Legislature imposed protectionist laws to prevent other empires from selling workboats inside the Confederation. Despite this, numbers of workboats designed by other races soon slipped across the frontiers of Confederation Space, being sold "under the table" to enterprising Confederation citizens who were not able to procure one through normal channels.

Federation Reporting Name: *Rhamphorhyncus*.
SSD is in *Module R11*. Use any PF counter.

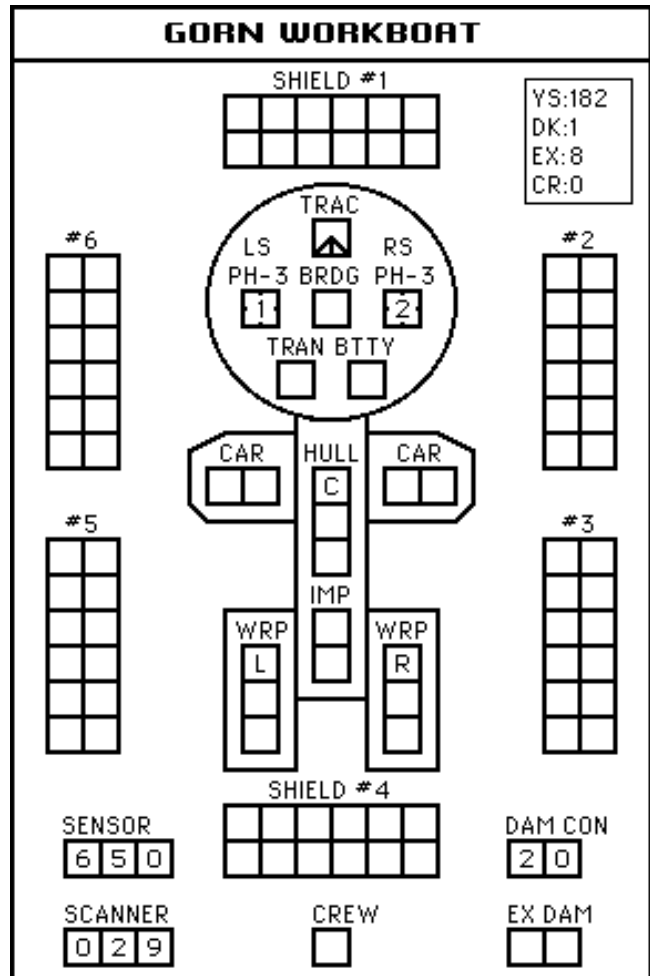

(R7.0) THOLIAN HOLDFAST

(R7.56) SCOUT DESTROYER (DDS): The first ship of this class was converted from the SC *Sentinel* in Y174. The only other known ship of the class was built as a replacement for the *Sentinel* when it was destroyed. The Tholians may not have built more scout destroyers simply due to the power and maintenance demands of the hull, but the later availability of the larger and more effective war cruiser scout cannot have helped. In any event, from Y174 until the appearance of the CWS, this was the most effective mobile scout the Holdfast could provide its small fleet.

Known Ship Names: *Sentinel*.

Special sensors are destroyed on “phaser” damage points.

This ship is nimble (C11.0).

This ship can use the gravity landing system (P2.432).

SSD and counter are in *Module R11*.

Designed by Stephen V. Cole.

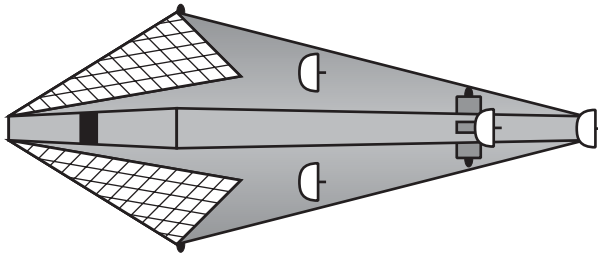

(R7.57) DESTROYER CARRIER (DDV): One ship of this class, the *Knife Edge*, appeared in Y176. It operated with a single PCA as an escort, but was reportedly escorted by a DE during some actions. (This cannot be confirmed as the only known DEs were assigned to CVAs or CWVs, and may have simply been another DD that happened to be in the same action.) While the fighter group it carried was no larger than that of the Black Widow, it packed a somewhat greater punch in its disruptors. Like the Black Widow class, the addition of the external fighter bays impacted the maneuverability of the ship.

Year	Escorts	Fighters
Y176+	PCA	4xSp-II, 4xSP-III

Known Ship Names: *Knife Edge*.

This ship is not nimble.

This ship can use the gravity landing system (P2.432).

SSD and counter are in *Module R11*.

Designed by Stephen V. Cole.

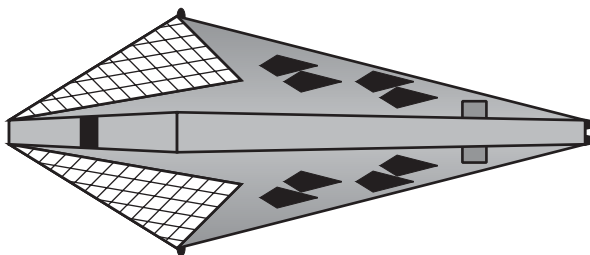

(R7.58) HEAVY WEB TENDER (HWT): The Tholians are believed to have built one ship of this class, and it was almost never seen. It appears to have been permanently stationed at the Tholian homeworld. The ship is believed to have been a Tholian reaction to the appearance of the Seltorians and their web breakers. The ship would supplement the powering of the outer rings of the web surrounding the Tholian homeworld, gaining time for other Tholian ships to come to defense of the Dyson Sphere. It is unclear why the Tholians did not produce many more of these ships, as it would have been clearly useful to station one at every base and allow their ships to carry fewer web generators, using the space for more weapons. There were no reported sightings of the ship after the Seltorian Tribunal forces were defeated by the ISC (and exterminated by the Klingons).

Known Ship Names: *Supercharger*.

Maneuver Limit: The HWT cannot accelerate by more than three movement points per turn (warp and impulse combined). It cannot disengage by acceleration.

SSD and counter are in *Module R11*.

Designed by Stephen V. Cole.

(R7.59) LARGE WEB TENDER (LWT): It is unclear if this was the same ship as the HWT, but appearing as a separate ship without the added auxiliary cruiser pods. The Tholians themselves are not saying, and the two ships were never detected operating at the same time (much less in the same battle). Like the HWT, the ship was first seen after the arrival of the Seltorian Tribunal, and like the HWT, there were no reported sightings of the ship after Y187.

Known Ship Names: *Supercharger*.

Maneuver Limit: The HWT cannot accelerate by more than four movement points per turn (warp and impulse combined). It cannot disengage by acceleration.

SSD and counter are in *Module R11*.

Designed by Stephen V. Cole.

(R7.PF) THOLIAN HOLDFAST FAST PATROL SHIPS

(R1.PF7) WORKBOAT: The Holdfast workboat was unique in that only the Tholians used it. The expense of converting a Tholian environment to that of another race was simply not cost effective. (You could purchase the workboat of another race for what it would cost to convert a Tholian workboat.) This was true the other way around, so that non-Tholian workboats were not used by the Tholians. The Tholians were also, even more than the Klingons, paranoid about anyone else being in their space, and any non-Tholian designed workboat was subject to destruction (usually with no warning) if it was discovered by a Tholian patrol. Still, there was a criminal element within Tholian space, and workboats were used by that element to rendezvous with the workboats of other races near (sometimes in) Tholian space to trade illicit goods.

SSD is in *Module R11*. Use any PF counter.

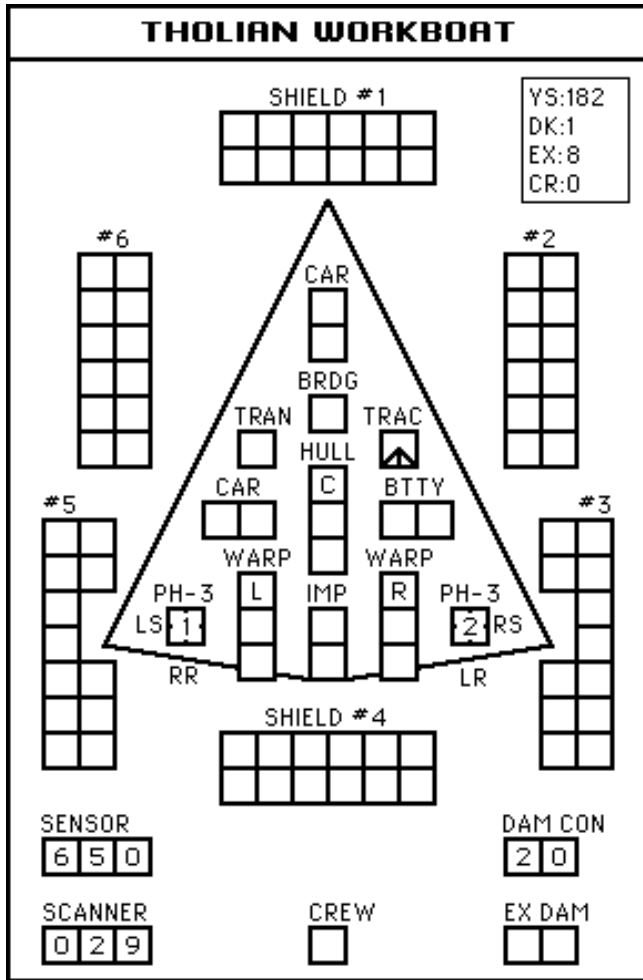

PERSPECTIVE: THEATER TRANSPORTS

Amateurs think about tactics; professionals think about logistics. -Soviet Army Proverb

Sustaining a fleet in combat was every bit as important as building it. Tacticians might think of war in terms of endless streams of starships leaving shipyards and going to the front lines, where they survived or perished primarily due to the tactics of their commanders and the strategies of their admirals.

But sustaining the fleet, by providing it with fuel, expendable weapons, replacements, repairs, and even food was what kept fleets at fighting strength. A fleet without fuel could not move to engage the enemy. A fleet without a resupply of drones, shuttles, fighters, T-bombs, pseudo-torpedoes, and everything else that tacticians “just assumed” would be available was at a serious disadvantage. A fleet without replacements for crewmen and Marines who had become combat casualties, or who had become sick or simply had endured more than could be asked, slowly lost capability. A fleet that could not quickly repair ships steadily lost strength, and all admirals knew that they would receive three times as many “new” ships from the repair yards as they did from the shipyards.

A network of ships, bases, and factories provided these supplies. Most were moved in standard freighters in convoys scheduled months in advance. These convoys provided a steady flow of the “expected” requirements, but could not respond to sudden emergencies, unexpected opportunities, or unique circumstances. Some flexibility in this “steady-rate” supply system could be had by sending more than was predicted to be needed and stockpiling the rest for emergencies, but this presented its own problems with storage (and protection of the stored stockpiles). Convoys of military-grade freighters were marginally faster, but could still only provide predicted increases in supplies based on plans for major offensives.

These “priority” matters were handled by special types of ships, including Prime Traders, Armed Priority Transports, and fast transports (Federation Express, or the equivalent). These ships, sometimes operating in packs or convoys, but often taking their chances on unescorted runs, picked up needed supplies in excess of the staff predictions from stockpiles along the supply chains and carried them to forward fleet elements.

An important part of these “priority” movers were the Theater Transports. Built on warship hulls, they were faster than most cargo ships, better protected, had more capacity than the small cargo ships, and could be sustained by front-line fleet repair facilities. They also had a critical distinction: they could move “pods” through the logistics networks, although they lacked the power or connections to use them in battle.

There were all manner of pods used by tugs and light tactical transports: carrier and battle pods, troop transport pods, fighter/gunboat transport pods, gunboat operations pods, and no end of other types. Pods were the original (and in some ways the ultimate) in multi-mission modular ships; whatever your fleet was short of, the shortage could be covered by a tug or tactical transport carrying the appropriate pod.

Pods could be moved by either a tug or light transport, a standard freighter, or a theater transport. The problem was that convoys were too slow to react to changing battle conditions, and if you had a tug available to carry the pod you wouldn’t need to take the pod to the tug in the first place. Theater transports could move the pods at starship speeds, bringing them to tugs and tactical transports able to use them to complete the mission.

(R8.0) ORION MERCHANTS AND TRADERS GUILD

(R8.54) PRIME TRAITOR (OPT): It is unclear which was developed first. Was the Prime Trader used by the various empires fielded first, or was it built based on this design operated by at least one (the records are just not clear) cartel? This ship is almost completely operationally identical to the Prime Trader. The principle difference was that it was equipped to do a little light larceny on the side (having double the transporter and tractor capacity and reduced science resources), and of course a suicide bomb. The rather larger contingent of boarding parties were specially selected for their acting abilities, as they would attempt to pass themselves off as simple passengers if the ship was boarded for inspection by the local police (or a warship). Other cartels eventually operated ships of this type.

Known Ship Names: *Artful Dodger* (Dragon Cartel) and *Raconteur* (Cluster Cartel).

Federation Code Name: *Prime Traitor*.

Cost of OAKDISC: 5

Cargo Boxes: 50 spaces (G25.12).

Landing (P2.43): powered; bonus (P2.431).

SSD and counter are in *Module R11*.

(R8.55) LIGHT PF TENDER (DWP): The Orions were fascinated by the deployment of small attack craft by the Lyrans, and stole the technology (or got it by bribing officials) as quickly as they could. As with more "law-abiding" empires, the Orion cartels at first believed that the new boats would need to be docked in an internal bay so that repairs could be conducted, and this design appeared to meet the deployment needs of the new attack craft. It could only repair PFs in its internal bay (which was accessed through a large hatch on the underside of the ship). During the first year of operation, the DWP could not flush the ion buildup of the PF engines at the external mech links, but later managed to install systems for this purpose. It is unclear how many ships of this type were built by the various Cartels. They were rented out as mercenaries, and various ships seem to have been sold by one Cartel to another at one time or another. It is known that several ships of this class were still being operated by different Cartels as late as Y189 for "special missions".

Known Ship Names: *Assassin's Den* (Pharoah Cartel), *Heathen Cove* (Penzance Cartel), *Mara Salvatrucha 13* (Hamilcar Cartel), *Omerta* (Lion's Heart Cartel), and *Wicker's Yard* (Omega Cartel).

Special sensor is destroyed on "torpedo" damage points.

This ship is nimble (C11.0).

Federation Code Name: *Outlaw-P*.

Cost of OAKDISC: NA.

Cargo Boxes: NA.

Landing (P2.43): gravity, aerodynamic, powered; bonus.

SSD and counter are in *Module R11*.

(R8.PF) ORION PIRATES FAST PATROL SHIPS

(R1.PF7) WORKBOAT: The Orion cartels did not have much need for workboats, at least not in such large numbers that they could not get by with workboats purchased (or stolen) from the local economy on which the given cartel preyed. The Orion Enclave, however, saw the market for workboats in the Federation and modified the design of the Buccaneer-C to meet the need. The Orion workboat was the single most common workboat in Federation space, and some were sold to the Klingons, Kzintis, and Romulans, especially after the General War. (Some were found in Gorn Confederation space despite the efforts of the Confederation's Legislature to prevent it.) The design is just a workboat. It cannot double its engines, does not have a suicide bomb, and does not have the built-in stealth features (the coating on the hull) of normal Orion PFs.

Federation Code Name: No reporting name was assigned, as these were lawful workboats.

SSD is in *Module R11*. Use any PF counter.

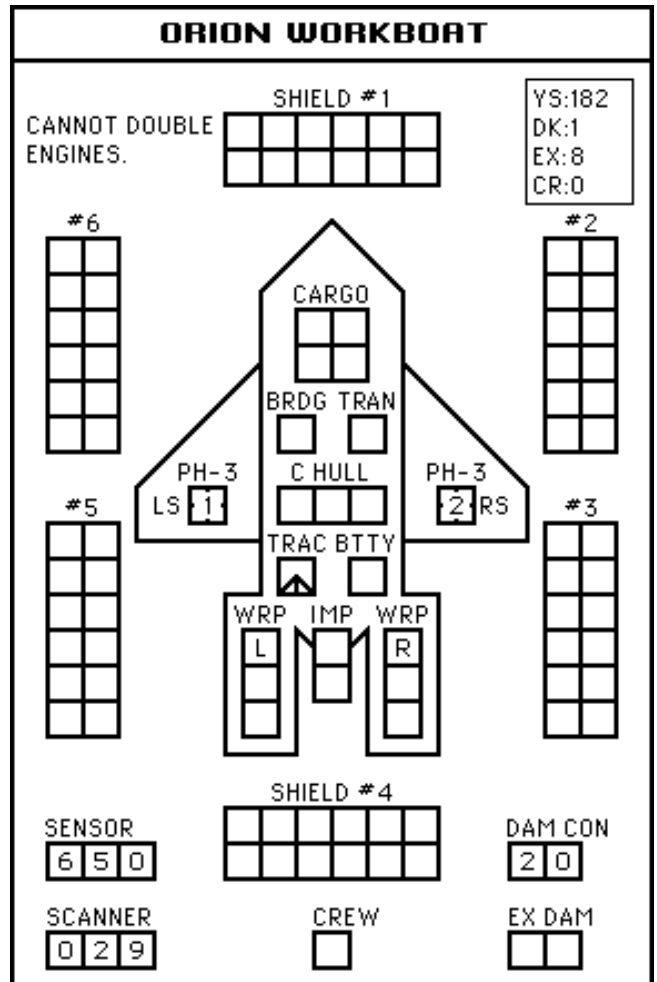

GENERAL NOTES ON SHIP CLASSES:

DIVISION CONTROL SHIPS: Division control ships were, in effect, low-cost SCS designs intended to use attrition units to fight and keep the ship itself clear of close combat (or any combat if possible). DCS units often escorted convoys for their last hundred parsecs to the front lines and conducted security patrols on open flanks.

MINI-TUGS: In *Federation & Empire*, players are often introduced to the mysterious “dedicated staff officers” who see that things are where they are needed, when they are needed. This most commonly deals with the movement of various tug pods (needed to quickly change a tug to a new mission), but later also deals with HDW modules, and many other things. Since the players are running the tugs, they know where they are and what they are doing, so they know the tugs are not running around exchanging pods. All they ever do is tell those dedicated staff officers to “Change Tug A from the heavy carrier mission to the battle mission”, and it is done. But how does the staff do it?

The answer is a combination of the plain old freighters . . . and the mini-tug.

The most commonly seen mini-tug is the Tholian CPC, and it pretty much defines the operations of such tugs. Their primary function is the rapid delivery of critical supplies that are used faster than the normal freighter system can handle. To this end they have considerable (for their size) cargo volume. But all of them also have the ability to carry pods. The movement of pods is not a constant for these small brutes. While able to move a pod strategically faster than a freighter, doing so severely taxes them (which is why the Tholians mostly used cargo packs, and built in the ability to carry such packs into most of their ships).

Their ability to make high-speed transits is what keeps the mini-tugs in operation, but only a government could afford the massive maintenance costs associated with keeping them in operation. Even at that, the cost is less than replacing each one with “real tug” to do the same job.

No mini-tug could carry more than one pod at a time, pods carried by mini-tugs are carried as cargo only.

NOTE: The Federation FFT is treated under these rules and able to carry one pod at a movement cost of 2/3rds, or a double weight pod at a movement cost of 1.0.

(R9.0) HYDRAN KINGDOM

(R9.115) TRANSPORT FRIGATE (FFT): The Hydran mini-tug was a good fighter due to its phaser-G, but not intended to go in harm's way. The SSD provides the data for both single-weight and double-weight pallets (or pods), but any pallets carried by this ship are inactive and every box in such a pallet is treated as a "cargo" damage point.

Known Ship Names: *Southern Zephyr*, *Sudden Surge*, and *Swift Sender*.

SSD and counter are in *Module R11*.

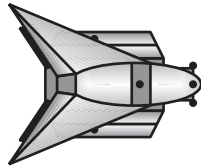

(R9.116) LORD HIGH EXECUTIONER DIVISION CONTROL SHIP (LHE): This ship appeared in Y180, at the same time as the Lord Paladin. It is obviously a conversion of a Lord Executioner, but it is not clear if it was a new build or if an existing LE was converted. The ship would be highly effective in hunting down Andromedan RTN nodes simply because its attrition units (PFs and fighters) were far better at the close-range game than the Andromedan units usually found defending such a node. This enabled the ship to hold out until its escorts and supporting ships could come up to destroy the Andromedan base, but was often very hard on the pilots and PF crews.

Year	Escorts	Fighters
Y180+	NAC, DWA	9xSt-2, 2xSt-H, 1xSt-E

Known Ship Names: *Hydramar*.

There are three shuttle bays; no (J1.59) transfers between the bays are possible.

Special sensors are destroyed on "torpedo" damage points.

SSD and counter are in *Module R11*.

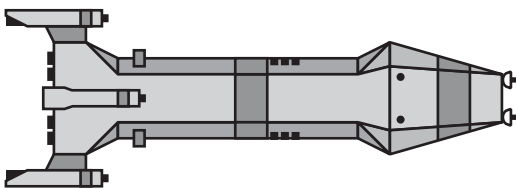

(R9.117) LIGHT PF TENDER (FDW): The Hydran economy was not able to respond as quickly to changing combat paradigms as the Navy wanted, taking nearly three years to respond to the Lyran deployment of interceptors in Y176. Despite extensive experience with both Klingon and Lyran PF operations in the intervening period, the first Hydran effort at deploying the new attack craft ran afoul of the same initial limitations. The light PF tender gave up much of its internal volume to install a repair bay, which would also fit replacement warp packs on the Harbinger interceptors (later Hellion and Harrier PFs). Like the rest of its type deployed by other empires, the Hydran light PF tender was eventually used for special missions and convoy escort duties. The ship did not normally operate fighters, but sometimes replaced one of its shuttles with a Stinger-F; this is shown on the SSD.

Known Ship Names: *Grim Resolve*, *Just Cause*, and *Terrible Command*.

Special sensor is destroyed on "torpedo" damage points. SSD and counter are in *Module R11*.

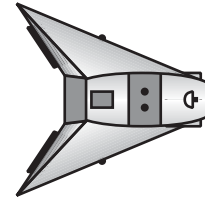

(R9.118) HUN FAST MEDIUM CRUISER (HUN): Perhaps misunderstanding the use of Lyran and Klingon fast war cruisers, the Hydrans built *Swiftsure* in Y178 and appear to have built two more ships later. Intended to supplement and support the Iroquois-Fs, the ship proved a vicious dogfighter (due to its high speed) but was too vulnerable to damage to conduct operations behind Coalition lines. It fought most of its battles during the General War hitting the Vudar incursion into Hydran space to try to prevent the successful establishment of a solid front. The *Swiftsure* was lost in a battle with an Andromedan force in Y194.

Known Ship Names: *Swiftsure*, *Ferocity*, and *Velocity*.

There are two shuttle bays; no (J1.59) transfers between the bays are possible.

SSD and counter are in *Module R11*.

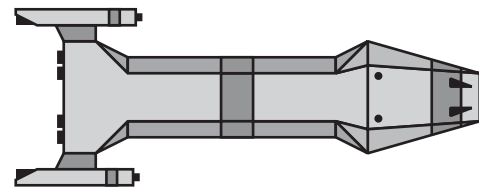

(R9.119) SCOUT PALLET (P-SC): Another pre-war scout pallet born from a mistaken idea of what electronic warfare would require. These were pressed into combat, which caused higher casualties among the tugs (and later LTTs) that were already in critically short supply.

Special sensors are destroyed on "phaser" damage points.

SSD is in *Module R11*. Use any pod counter.

(R9.120) HEAVY FIGHTER RESUPPLY PALLET (P-CR): This pallet was used to ferry Super-Stinger heavy fighters to those few carriers modified or built to use them. This pallet can carry fighters, but cannot operate, land, refuel, or rearm them. The one shuttle bay was used to "warm up" replacement fighters, which could only launch once, and could not land. The bay did have ready racks (marked with an "H") and could fully arm the fighters before sending them on their way to their carriers. This type of pod can carry standard fighters (under the same restrictions) but cannot arm them via ready racks as the racks are for heavy fighters; they will have to use (J4.892). The shuttle bay includes an HTS to facilitate cargo transfer.

SSD is in *Module R11*. Use any pod counter.

(R9.121) PF TRANSPORT PALLET (P-PT): Able to carry a dozen PFs to refill the mech links of true PFTs, this pallet was used mostly by LTTs as it did not require a full-sized tug to operate. Each pallet could carry twelve PFs, but could not operate, repair, refuel, or rearm them. Once the PFs were launched, they had to transfer to a regular PFT to start operations, which was, after all, the point. PFs launched from these pallets will only have one crew unit and cannot carry more until they are serviced by a true PFT by having one repair point allocated to them by the PFT's repair systems.

SSD is in *Module R11*. Use any pod counter.

(R9.122) PEGASUS SURVEY CRUISER (PGR): With the wartime disaster of losing most of the Kingdom, the guilds converted one of their Pegasus scouts to this class in Y174, to help exploit more resources in the uncharted wilderness of the Lost Colonies. Records indicate that the ship may not have been used as a survey cruiser, but operated as a scout and to support some marine landing operations. The ship was later converted into a PFT in Y184.

Known Ship Names: *Reliable*.

There are four shuttle bays; no (J1.59) transfers between the bays are possible.

Special sensors are destroyed on "torpedo" damage points.

SSD and counter are in *Module R11*.

(R9.PF) HYDRAN KINGDOM FAST PATROL SHIPS

(R1.PF7) WORKBOAT: The Hydran Kingdom had a huge need for workboats as replacing skiffs destroyed by the Coalition invasion was simply too expensive. Large numbers of workboats were built by the various guilds, and, even during the General War, were sold to the Klingons, Lyrans, and later the Vudar (through Orion middlemen) as well as the Hydran Monarchy. The guilds were able to offer the other races a good price as many exile race planets built PFs, and built the corresponding workboats to suit their own atmospheric needs. All guilds operated a number of workboats, and they were produced so fast that (given the lack of tight oversight needed to foster the guilds' cooperation) government auditors had no idea how many were built, much less who they were sold to. When the General War concluded, some guilds purchased workboats from the Klingons, Lyrans, Orions, Vudar, and even Jindarians if they were offered a deal cheap enough to defray the cost of converting the life support systems. (This was possible as some guilds would overcharge as much as they thought they could get away with.) Some of these eventually wound up in the hands of the government, and the sight of a Lyrans or Klingon workboat carrying a government minister was not totally unknown in the Hydrax system particularly if the minister was from one of the oxy-nitrogen Exile Races.

SSD is in *Module R11*. Use any PF counter.

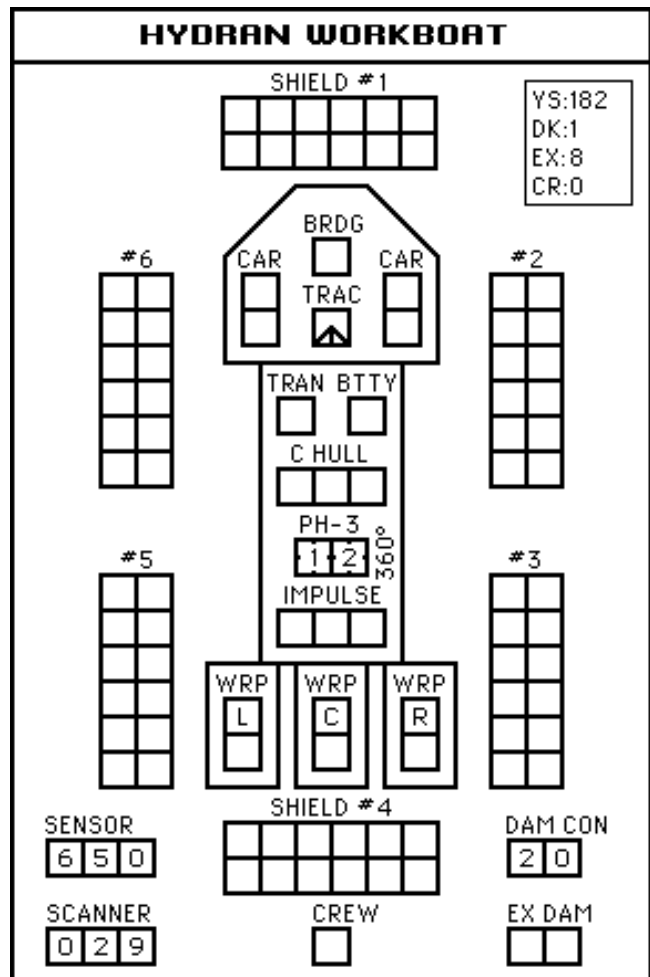

(R10.0) ANDROMEDAN INVADERS

ANDROMEDAN MONITORS

As Operation Unity drove towards the Lesser Magellanic Cloud, the Galactic Powers encountered new kinds of Andromedan ships not seen before. These came to be referred to as Andromedan monitors, as they were Motherships in size, but were found to lack displacement devices, and so were unable to move along the Rapid Transit Network. Fortunately for the Galactic Powers, there was never more than one encountered at any one Andromedan base (including the Desecrator). However, as they did not have displacement devices, they did not prevent Andromedan reinforcements from reaching a base under attack. Attacking an Andromedan battle station that was also defended by an Immobilator monitor and two Dominators could be an extremely daunting task.

Andromedan monitors have two kinds of hangars. They have their normal hangar and a multiple weapons platform hangar. The multiple weapons platform hangar (marked "M-HNGR" on the SSD) is not an internal bay, but a series of special docking stations on the hull of the ship with facilities to fuel MWP's; they are destroyed by "shuttle" damage points. Destroyed MWP hangars cannot dock MWP's, and non-MWP units cannot dock to these hangars by any means. If an MWP is docked to a hangar at the point it is destroyed, the MWP is not affected (damage to a monitor is never applied to the MWP's docked externally to it), but if it undocks, it cannot redock at that station until the station is repaired. Normally Andromedan Motherships cannot have such external stations as the high multiples of warp they achieve using the RTN develops enough friction from the few random molecules found even in deep space to rip off the MWP's. Monitors are not capable of achieving these speeds.

MWP's dock and undock from the Monitor using the rules for PF's docking and undocking from a PF tender (K2.3). Note that the only tractors available to an Andromedan monitor are its TR beams.

A monitor can operate any sort of MWP, but can only provide mines to an mobile mine platform from its own mine racks, i.e., a monitor cannot begin a scenario with an MMP already loaded with mines unless those mines are deleted from its own mine racks. MWP's carried by a monitor are in addition to any MWP's operated by the base or planet they are defending.

The standard hangars of an Andromedan monitor can only hold energy modules and decoy SSUs (G35.512). A given monitor can include as many energy modules and/or decoy SSUs as its hangar can hold and can be purchased as part of the battle force, they are not limited by (S8.221) or (G35.512).

Monitors are equipped with mine racks, but are minelayers, not minesweepers. The mines for the racks must be purchased; they are not free. They are purchased as part of the force, not with Commander's Options Points. Mines in the mine racks can be laid from the racks, or unloaded from the racks for use by the ship's transporters. Note that nuclear space mines cannot be transported (G19.49). A Monitor cannot unload more mines from its racks than it has space available in its normal T-bomb storage. If a Monitor places a T-bomb with one of its transporters it may on the next turn unload a small mine from one of its mine racks to replace that T-bomb.

(R10.65) CONCRETOR MONITOR (CCR): First encountered during Operation Unity, several ships of this class were destroyed by Galactic Powers. Based (apparently) on the Conquistador hull, it carried six mobile weapons platforms.

There are confirmed reports that some ships of this class were encountered defending positions inside the Milky Way Galaxy in both the Alpha and Omega sectors.

Known Federation Reporting Names: None, the ships were simply recorded by the location where they were encountered.

Mothership: Hangar for one medium satellite ship (G19.11), but restricted to listed satellites.

Satellites: Energy modules and decoy SSUs.

External MWP docking for six MWP's.

SSD and counter are in *Module R11*.

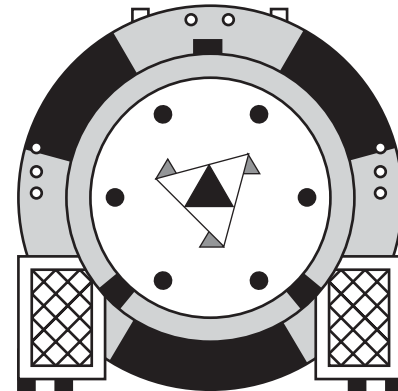

(R10.66) IMMOBILATOR MONITOR (IMB): First encountered during Operation Unity, at least four ships of this class were destroyed by Galactic Powers (including one at the Desecrator). Based (apparently) on the Intruder hull, it carried a dozen mobile weapons platforms.

There are conflicting reports that one or more ships of this class were encountered defending positions inside the Milky Way Galaxy in both the Alpha and Omega sectors.

Known Federation Reporting Names: None, the ships were simply recorded by the location where they were encountered.

Mothership: Hangar for three medium satellite ships (G19.11), but restricted to listed satellites.

Satellites: Energy modules and decoy SSUs.

External MWP docking for twelve MWP's.

SSD and counter are in *Module R11*.

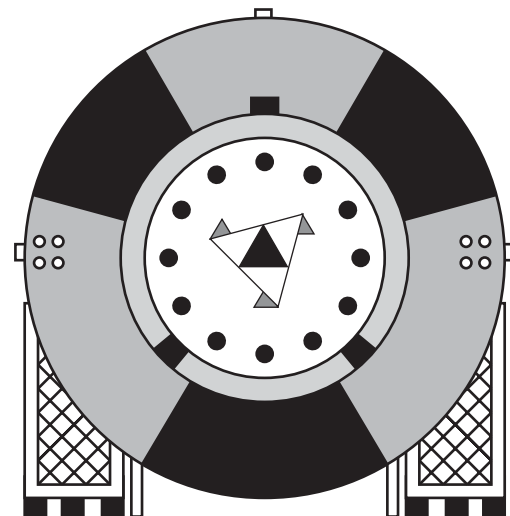

(R10.67) CONSTRUCTION BATTLE STATION (BAC): Battle stations of this type were encountered in the Alpha Octant, Omega Octant, and the Magellanic Cloud. One of the three "satellite bases" attached to the core was equipped with a system of collapsible construction systems that enabled the base to build satellite ships, from mobile weapons platforms up to Python destroyers. There is no data indicating that such bases were able to build Motherships. The time interval needed to build a satellite ship is unknown, but probably varied widely depending on just what satellite ship was being built and the resources that were available to the base. It is known that the Andromedans engaged in considerable economic activity in support of their operations (cargo sleds, mining sleds). Obviously not all of the material being gathered by those operations was being sent back to the Magellanic Cloud to build ships that would then fly to the Milky Way. It is not known how many of the Andromedan bases that were eventually destroyed were of this type. It is possible that some of the bases destroyed were in fact construction stations, but that their facilities had been shut down and collapsed into the base. And of course it is always possible that a given Construction Battle Station started as a normal battle station, and then had one of its satellite bases replaced with a construction base.

There are no current indications that construction satellite bases were placed on their own, or were used as the second satellite base of an Andromedan base station, but these circumstances have not been ruled out.

Known Federation Reporting Names: None.

Base: No internal docking.

Satellites: None.

MWPs can be added to the base under (G35.633).

SSD and counter are in *Module R11*.

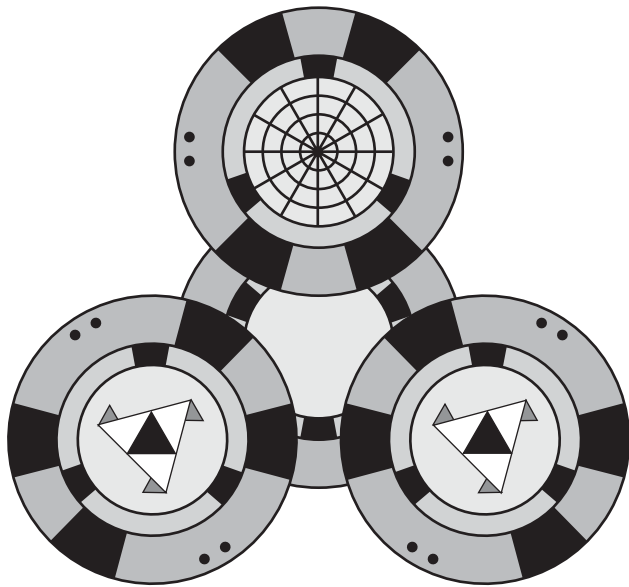

(R10.68) RECONNAISSANCE COBRA (CBR): This variant of the Cobra gave up one of its light tractor-repulsor beams to mount a displacement device. This enabled it to move, independently of a Mothership, along the RTN. The apparent function of the ship was to poke its nose into planetary systems to see if there was anything worth attacking, or any defenses present. There were a limited number of Motherships, and the Andromedans could apparently build and deploy ships of this class in numbers, and the loss of one of them was simply a cost of doing business much easier to absorb than the loss of a Python. Pairs of these ships sometimes attacked small convoys, or conducted raids on isolated planetary systems. The purpose of that was to sow confusion and prevent the Galactic Powers from massing their forces against the Andromedans by forcing them to disperse to guard targets that might be attacked. This would then allow the Motherships to strike at the isolated fleet units with superior power.

Known Federation Reporting Names: None.

Satellite Ship: Medium size (G19.211).

SSD and counter are in *Module R11*.

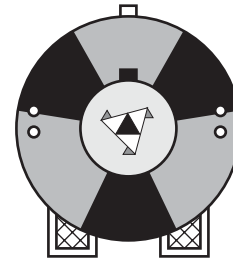

(R11.0) LYRAN STAR EMPIRE

(R11.91) ALLEYCAT-P LIGHT PF TENDER (DWP): This is the first ship of its type to appear in the Alpha Octant. The Lyran High Command had initially envisioned interceptors as a replacement for the Klingon bombers being built under license, but tests on the first boats revealed that it was possible they could survive being dragged through space attached to the hull of a ship. It was known that shuttles could be mounted on mech links if the hull was small enough (which was why skiffs and modular couriers were able to carry shuttles at high speed without wrecking them). But the warp fields of starships moving at high speeds flexed enough to smash even the smallest shuttle (which is why shuttles on balcony systems are swept away when the ship disengages). This flexing made it impossible to use bombers on ship mech links, much less carry fighters (the Federation would eventually circumvent this problem with specially designed and hard to construct semi-external shuttle bays). The interceptor design was, however, large enough (although smaller than a skiff) to resist the forces of the conflicting warp fields.

Excited by this prospect, the Lyran engineers moved ahead to develop a larger mech link that could hold the new attack craft. The excitement lasted until they talked to some of the test crews who pointed out that the boats would probably be seriously damaged and in need of repair, repairs that could not be done by deck crews. Furthermore the engines would need to be flushed of ionic build up (and warp packs had not been invented yet, but other engineers were feverishly at work on that project). The solution to these problems would obviously involve an internal bay, larger than had yet been seen. A design submission to the Admiralty resulted (after the admirals reviewed the performance data on the attack craft) in a contract being let to construct a modified DW to operate the craft. The center section of the DW was hollowed out, and anything not needed (like the spare shuttle) was sacrificed to create the bay and the unusually large doors the boats would require to dock in it.

The first DWP was ready at practically the same time the first prototype Lynx squadron (with only three boats) was ready. The ship operated for most of the year and, together with the boats, showed the way to the future. By Y178, the collapsible repair bays had been developed and there was no real need to build PFTs with internal bays. The Lyrans, however, produced several more ships of the design for various "special operations".

Known Ship Names: *Blood Hunter* (Blood Star County), *Golden Hunter* (Golden Fang County), *Hidden Hunter* (Hidden Dagger County), and *Hunt Master* (Foremost Duchy).

UIM: not available.

Refits: Included in the design.

SSD and counter are in *Module R11*.

(R11.92) RUNNING JAGUAR FAST WAR CRUISER (CWF): This is the Lyran entry into the fast war cruisers field. Like most of its breed, it was designed at the same time as the basic war cruiser to support and operate with the larger fast cruisers and fast dreadnoughts. It was then relegated to the filing system until Y175, when the Lyrans decided they needed more raiders, but not enough true cruisers could be built to meet all their needs. The first CWF entered service in Y176 and proved disappointing as a raider. It was effective at intercepting enemy raiders, and two (possibly three) more were built or converted to the design. At least one ship of the class was lost when the raider it intercepted turned out to be an X-technology cruiser. During the Andromedan War, the

Lyrans tried to include one such ship in each searching force, since it could reach the scout that found a transportation node faster than any other ship.

Known Ship Names: *Black Terror* (Black Stripe County), *Predator Spirit* (Predator County), *Silver Streak* (Silver Moon County), *Swift Doom* (Doom Star County), and *White Ghost* (White Stripe County).

UIM: Available for purchase.

The ship had all refits except the mech link refit and UIM refits when it entered service. The dates on the SSD reflect when the refits would be added to the ship had it been built earlier. The mech link refit was installed in Y178.

SSD and counter are in *Module R11*.

(R11.93) ALLEYCAT-T WAR DESTROYER TRANSPORT (DWT): The success of the FFT in supporting the distant fighting forces in Kzinti space and on the Federation border led the Lyrans to convert a few FFTs and damaged DWs to this larger design, which was able to carry the pallets they were still building for their tugs. Prior to the design of the DW, the smallest ship that could have carried a pallet was the light cruiser. The wider space between the left and right engines of the DW design made it possible to attach a tug pallet, albeit the pallet had to be attached sideways. It was perhaps the most heavily-armed of the mini-tugs. It also gained efficiency in the movement of pods due to an oddity of warp dynamics, i.e., the movement cost is only 0.75 with a pod, and 1.0 with a double weight pod. The SSD provides the data for both single weight and double weight pods or pallets, but any pods or pallets carried by this ship are inactive and every box in such a pod or pallet is treated as a "cargo" damage point.

Known Ship Names: *Apex Deliverer* (Apex County), *Red Claw Express* (Red Claw County), *White Stripe Express* (White Stripe County), *Dark Storm Provider* (Dark Storm County), and *Pelt Provider* (Pelt Hunters County).

UIM: not available.

Refits: ESG capacitor refit in Y168, Plus refit in Y168, phaser refit in Y172, and mech link refit in Y178. The ship never received the power pack refit as it would have interfered with the ship's ability to move pods and pallets.

SSD and counter are in *Module R11*.

(R11.94) CHEETAH-T TRANSPORT FRIGATE (FFT): The Lyrans came late to the mini-tug concept. Their pallets (unlike the Hydran pallets) could not be carried on anything smaller than a light cruiser hull prior to Y165. The acquisition of the Klingon pods for use by the Lyran LTTs made mini-tugs feasible. The SSD provides the data for both single-weight and double-weight pods, but any pods carried by this ship are inactive and every box in such a pod is treated as a "cargo" damage point.

Known Ship Names: *Dagger Bearer* (Hidden Dagger County).

UIM: not available.

Refits: ESG capacitor refit in Y168, Plus refit in Y168, phaser refit in Y172, and mech link refit in Y178.

SSD and counter are in *Module R11*.

(R11.95) KING JAGUAR-V NEW MEDIUM CARRIER (NCV): An obvious variant that combined a slightly-modified center section of a King Jaguar new heavy cruiser with the sides of the CVL based on the war cruiser. While obvious, the Lyrans never deployed one during the General War, perhaps indicating that they were having problems supplying fighters for the carriers (and bases) they had.

Year	Escorts	Fighters
Y176-178	CWA, DWA or FFA	12xZ-V
Y178-181	CWA, DWA or FFA	12xZ-Y

Y181-184	CWA, DWA	12xZ-YB
Y184+	CWA, DWA	12xZ-YC

Known Ship Names: *Night Thunder* (Night Roar County) is apocryphal since no ship of this class was built.

UIM: not available.

Refits: Mech link refit in Y178 would probably have been installed on the ship when it was built, but is shown as a separate refit.

SSD and counter are in *Module R11*.

(R11.96) KING JAGUAR-S NEW HEAVY SCOUT CRUISER (NSC): The Lyrans built at least one ship of this class, emulating the success the Klingons had enjoyed with the D6S. It was a powerful electronic support platform and might have won the war for the Coalition had it been available earlier.

Known Ship Names: *Dark Shadow* (Dark Storm County), *Enemy's Shadow* (Enemy's Blood Duchy), *Night Shadow* (Night Star County), and *Red Shadow* (Red Claw County).

Special sensors destroyed on "torpedo" damage points.

UIM: not available.

Refits: Mech link refit in Y178.

SSD and counter are in *Module R11*.

(R11.97) KING JAGUAR-T NEW COMBAT TUG (NTG): The Lyrans had lost many tugs in the opening stages of the war, far more than they had anticipated. Freighters and strategic transports were overburdened, particularly with trying to supply Lyran expeditionary forces supporting the Klingons against the Federation (and later the Tholians). The Lyrans built one ship of this design in Y176, and more before the General War ended. The design was successful, and several more were built during the subsequent Andromedan War. The ship was able to operate two Klingon/Lyran pods, or two Lyran pallets in the same manner as the Cougar and Puma.

Known Ship Names: *Dark Storm Master* (Dark Storm County), *Golden Master* (Golden Fang County), and *Hidden Master* (Hidden Dagger County).

UIM: Available for purchase (S3.2).

Refits: Mech link refit in Y178.

SSD and counter are in *Module R11*.

(R11.98) LYRAN K-SCOUT POD: Unlike other scout pods, these were designed during the war to enable the LTTs (which could not carry the pre-war pallets designed for the tugs) to operate in the scout-tug role. They were built using the frame of a Klingon pod with systems installed by the Lyrans. The Klingons could not use this pod due to the complicated power linkage connections for the special sensors.

Special sensors destroyed on "phaser" damage points.

SSD is in *Module R11*. Use any pod counter.

(R11.99) LYRAN K-TYPE HEAVY FIGHTER TRANSPORT POD: These were used to resupply the few carriers operating heavy fighters, since the existing FCRs could not handle the larger machines. These pods can carry fighters but cannot operate, land, refuel, or rearm them. The one shuttle bay was used to "warm up" replacement fighters, which could only launch once, and could not land. The bay did have ready racks and could fully arm the fighters before sending them on the way to their carriers. This type of pod can carry standard fighters (under the same restrictions) but cannot arm them via ready racks as the racks are for heavy fighters; they will have to use (J4.8962) and (J4.892). The shuttle bay includes an HTS to facilitate cargo transfer.

SSD is in *Module R11*. Use any pod counter.

(R11.100) LYRAN K-TYPE PF TRANSPORT POD: Able to carry six PFs, these pods were used to ferry replacement PFs to front-line PF tenders. Each pod could carry six PFs, but could not operate, repair, refuel, or rearm them. Once the PFs were launched, they had to transfer to a regular PFT to mount operations. PFs launched from these pods will only have one crew unit and cannot carry more until they are serviced by a true PFT by having one repair point allocated to them by the PFT's repair systems.

SSD is in *Module R11*. Use any pod counter.

(R11.101) LYRAN SCOUT PALLET: This unit was created before the War for the specific purpose of providing the most powerful jamming platform among the Four Powers.

Special sensors destroyed on "phaser" damage points.

SSD is in *Module R11*. Use any pod counter.

(R11.102) LYRAN PF TRANSPORT PALLET: This unit was used by fleet tugs to re-supply PFTs and casual flotillas. Each pallet could carry twelve PFs, but could not operate, repair, refuel, or rearm them. Once the PFs were launched, they had to transfer to a regular PFT to conduct operations. PFs launched from these pallets will only have one crew unit and cannot carry more until they are serviced by a true PFT by having one repair point allocated to them by the PFT's repair systems.

SSD is in *Module R11*. Use any pod counter.

(R11.PF) LYRAN STAR EMPIRE FAST PATROL SHIPS

(R1.PF7) WORKBOAT: The Lyran Star Empire had a huge need for workboats to supplement its skiffs, but desperately needed as many combat PFs as it could get to the front lines. This created the oddity that the majority of "Lyran-designed" workboats were produced under contract, or outright purchase, from the Lyran Democratic Republic during the final years of the General War. When the General War concluded, the LDR continued to be major supplier of PFs to the war-weakened Lyran Empire's economy, but the counties bordering Hydran space were not above buying Hydran workboats to fill their needs. The Red Claw Duchy bought many workboats from the WYN Star Cluster, acquiring at least some Kzinti workboats from that source. Klingon workboats made their way into Lyran space through both the LDR and outright purchase by the Foremost Duchy. Far Stars Duchy purchased workboats from the Jindarians, and everyone bought workboats from the Orions.

SSD is in *Module R11*. Use any PF counter.

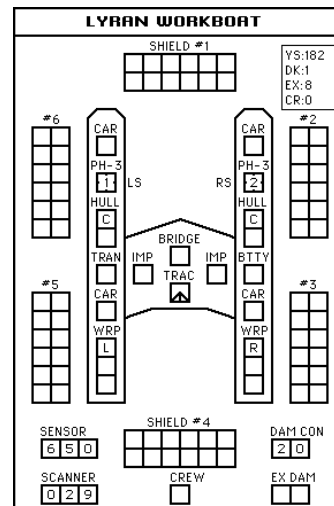

(R12.0) WYN STAR CLUSTER

(R12.51) DIVISION CONTROL SHIP (DCS): The Usurper never built such a ship, but he might have if he had delayed his departure from the WYN Star Cluster. There has been endless discussion that due to the weakness of the Hegemony's Crown Prince, the Usurper should have waited and built more ships for his campaign. Waiting another year or two might have caused the whole Hegemony to just fall into the Usurper's lap.

There are persistent reports that the governing council which took over the WYN Star Cluster after the Usurper left built one such ship, but these are generally regarded as mistaking an Orion BCS for a WYN ship.

This ship's shuttle bay is a tunnel deck (J1.58), a single bay with hatches on both sides of the ship. Shuttles can launch from or land at either hatch.

Year	Escorts	Fighters
Y187+	CWA, DWA	12xTADSC

Known Ship Names: None.

This ship can control a number of seeking weapons equal to double its sensor rating.

Special sensors are destroyed on "phaser" damage points.

SSD and counter are in *Module R11*.

(R12.52) ORCA-F FAST WAR CRUISER (CWF): There are rumors that the Usurper built one ship of this class to use as a raider against the Kzinti Crown Prince. Given the general failure of fast war cruisers as raiders, if this ship was built, it probably did not accomplish much. It would have been a powerful combatant within the Cluster and could certainly have responded to any incursion faster than any other ship in the Cluster's central reserve fleet. This fuels speculation that one was built as a fast responder in Y188.

Known Ship Names: None.

SSD and counter are in *Module R11*.

(R12.PF) WYN STAR CLUSTER FAST PATROL SHIPS

(R1.PF7) WORKBOAT: The WYN Star Cluster would seem to have a very small need for workboats to supplement its skiffs. Most systems within the Cluster are relatively close, and there is not really any place within Cluster space that cannot be reached by a shuttle. The Cluster, however, began building workboats almost as soon as it designed its first real PF due to their operational advantages. (There is considerable debate about whether the Cluster built PFs and then designed a workboat, or built a workboat and then designed a PF.) The principle reason was that the Cluster had an excess production capacity to produce PFs (particularly after taking over the Orion Cartel shipyard within the Cluster), and burgeoning markets outside the Cluster in the Empires that surrounded it. Even undercutting the prices some manufactures demanded for new (or refitted) workboats, the Usurper could turn a profit on the boats. This helped build the war chest he would need to "regain" his throne (as he insisted, others insisted he was trying to steal it).

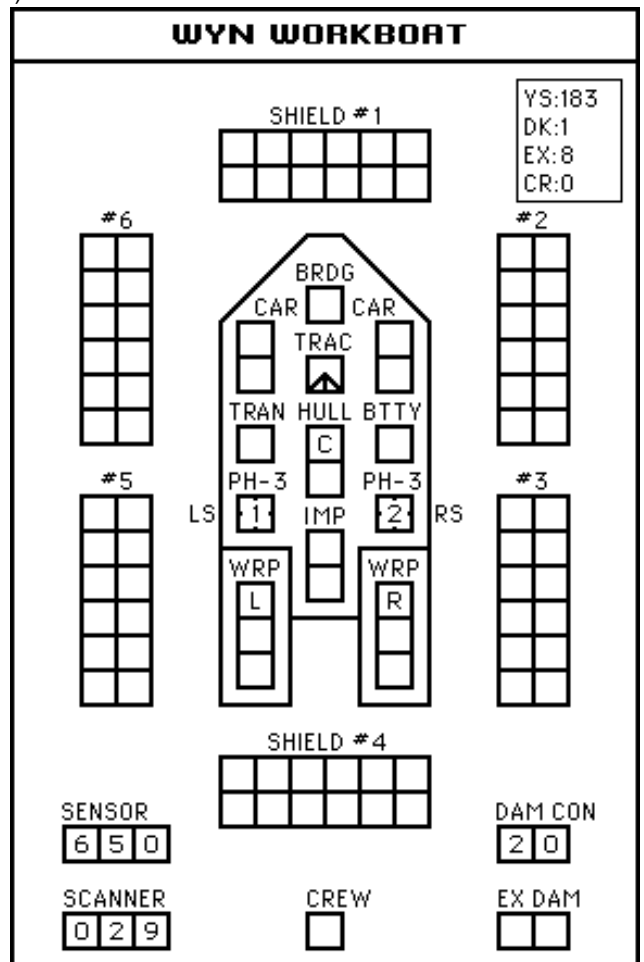

SSD is in *Module R11*. Use any PF counter.

PERSPECTIVE: CIVILIAN MISSION SHIPS

Few realize that the real purpose of “skids” was not to improve standard freighters making long-haul runs across their empires, but to create civilian “mission ships” which could undertake no end of worthwhile tasks using commercial freighter drive and control units. (Being in mass production, such things were readily available.)

A small freighter “hull” (drive unit and control unit) could carry three skids (and most had only one or two), while a large freighter “hull” could handle six (most had four, some had two and some had six). Given the vast number of different skids available, a civilian special mission ship could be readily created for any task or purpose.

Local governments often combined small freighter “hulls” with self-defense, fighter, and police skids to create system defense ships. Rarely, these had gunboat ducktails, turning them into micro-PFTs.

Colonial governments often combined small freighter “hulls” with convoy command, police or self-defense, and other skids to create a “flagship” able to control all of their “forces”.

Colonial governments also created “space guard” ships by combining repair/salvage/recovery, search/rescue, shuttle, and/or police skids and sometimes a workboat ducktail.

Corporations seeking new resources often combined small freighter “hulls” with accommodation, science, shuttle, power, and or mining skids.

Corporations developing resources they had already found often combined mining, accommodation, factory, cargo, shuttle, and other skids (and perhaps a workboat skid or workboat ducktail once workboats became available).

Any number of other combinations could be created, making small freighters (those without cargo pods) into the ultimate “modular” space ships.

(R13.0) INTER-STELLAR CONCORDIUM

(R13.83) DIVISION CONTROL SHIP (DCS): One of many designs included in the Pacification Fleet, it reflects that the ISC (without serious wartime experience) would, and did, try any design concept that seemed plausible.

Year	Escorts	Fighters
Y184+	CEA, DEA	8xFDF, 3xFTK, 1xFEK

Names: *Peacebringer*.
 Balcony positions: 4
 SSD and counter are in *Module R11*.

(R13.84) SYSTEM DEFENSE DESTROYER (NDD): When the Andromedan attack divided the ISC pacification forces into isolated cantonments, each was thrown on its own resources to survive. Some did not, but those that did excelled at improvisation, taking existing ships into their limited repair facilities and increasing their combat power. The system defense destroyer was an example of this. The added lower structure provided the destroyer with more firepower, but only to the extent of making it in essence a relatively-slow heavy destroyer rather than a light cruiser.

Known Ship Names: Retained the name of the destroyer converted.

No balcony.
 SSD and counter are in *Module R11*.

(R13.85) SYSTEM DEFENSE FRIGATE (NFF): The system defense frigate used the same lower structure as the system defense destroyer, which made for ease of production as the structure could be added to a destroyer or a frigate. Adding a plasma-G while retaining the existing plasma-Fs was a notable upgrade in the firepower of a frigate.

This ship is not nimble.

Known Ship Names: Retained the name of the frigate converted.

No balcony.
 SSD and counter are in *Module R11*.

(R13.86) LIGHT PF TENDER (DDP): The ISC began experimenting with small attack craft in response to the deployment of such units by their neighbors (and by the Orions). Reports that the Lyrans and Klingons were employing the boats from ships led the ISC to experiment with the concept. A destroyer was modified to service the new interceptor design. Not knowing that the Lyrans and Klingons had already deployed collapsible repair bays, the ISC found the DDP design disappointing as the ship could not operate effectively in an echelon while trying to internally dock a damaged interceptor for repairs. This experience may have delayed the ISC's development of true PFs by a year or more. The lone DDP remained in service and served through the Pacification campaign. It was constantly shifted from one fleet to another for various "special missions" and was eventually destroyed by an Andromedan Conquistador in the opening move of their offensive. Records are unclear if the Concordium built any more ships of this class.

Special sensor is destroyed on "torpedo" damage points.

Known Ship Names: *Peacesayer*.

No balcony.
 SSD and counter are in *Module R11*.

(R13.87) FAST LIGHT CRUISER (CLF): The ISC fast light cruiser was not built as a raider (unlike the fast war cruisers of other races), but as special reserve ship. The Concordium's admirals had concluded that several such ships would be useful in moving rapidly down the separation zones between the warring races to respond to incursions. The ships would be able to engage and delay efforts by the warring races to attack each other (or the Concordium's logistics) until heavier warships could arrive. At least three ships were in service at the height of the Pacification, and several more were built to act as reserves within Concordium space to respond to Andromedan raids on key areas.

Known Ship Names: *Constant*, *Inescapable*, *Swift Judgment*, *Swift Pursuit*, *Swift Justice*, and *Swift Vengeance*.

Balcony positions: 2
 SSD and counter are in *Module R11*.

(R13.88) FAST BLOCKADE RUNNER (CBR): This ship was designed to deliver vital supplies to isolated cantonments. It was not designed to carry any sort of pod, as doing so would have slowed it up. It was hoped that the ship would be able to outrun pursuit to deliver needed supplies to isolated cantonments. The first ship in the class actually traveled all the way to the Lyran-Klingon border to deliver the vital components that a cantonment needed to keep its PPDs operational. Essentially the ships would dash from cantonment to cantonment, stopping in each one to refuel and make repairs to its engines. Destroyer transports could not do the job, as their smaller size and slower speed made them easier for blockading forces to destroy. The ISC built five ships in this class, one of which was destroyed before negotiations allowed the Concordium to withdraw its remaining pacification forces back to its own space. After retreating to their own space, the Concordium had no real need for the ships, but it is not clear if the remaining ships were converted to fast raiders or junked. There are indications that at least one of the ships was used during Operation Unity to bring vital spares to the front line units, but this has not been confirmed.

Known Ship Names: *Messenger*, *Truthbearer*, *Winged Truth*, *Winged Voice*, and *Wordbearer*.

Balcony positions: 2
 SSD and counter are in *Module R11*.

(R13.89) SCOUT POD (P-SC): The ISC built scout pods, but unlike other races, used them heavily, at least initially. The ISC had large borders with the Romulans and Gorns, and did not have a system of defenses that had been built over the previous hundred or so years to guard them. Previous to encountering their neighbors, the principal problem for the Concordium was the occasional space monster. As the Concordium built its defenses it frequently sent a tug with the scout pods to investigate possible incursions. The pods were almost mothballed before the Pacification campaign began. By that time, the Concordium's web of defenses was well established. Therefore tugs would be almost exclusively working on supporting the pacification and thus would not be available to use the scout pods. The pods, however, remained available, and after the failure of the Pacification campaign (due to the Andromedans) were used once more.

Special sensors are destroyed on "phaser" damage points.

SSD is in *Module R11*. Use any pod counter.

(R13.90) HEAVY FIGHTER RESUPPLY POD (P-HFR): Used to resupply the few carriers operating heavy fighters, since the existing FCRs could not handle them. These pods can carry fighters but cannot operate, land, refuel, or rearm them. The one shuttle bay was used to "warm up" replacement

fighters, which could only launch once, and could not land. The bay did have ready racks and could fully arm the fighters before sending them on the way to their carriers. This type of pod can carry standard fighters (under the same restrictions) but cannot arm them via ready racks as the racks are for heavy fighters (marked "H"); they will have to use (J4.8962) and (J4.892). The shuttle bay includes an HTS to facilitate cargo transfer.

SSD is in *Module R11*. Use any pod counter.

(R13.91) PF TRANSPORT POD (P-PTT): Able to carry six PFs, these pods were used to ferry replacement PFs to front-line PF tenders. Each pod could carry six PFs, but could not operate, repair, refuel, or rearm them. Once the PFs were launched, they had to transfer to a regular PFT to begin operations. PFs launched from these pods will only have one crew unit and cannot carry more until they are serviced by a true PFT by having one repair point allocated to them by the PFT's repair systems.

SSD is in *Module R11*. Use any pod counter.

(R13.92) LIGHT SCOUT POD (P-LSC): The ISC deployed this pod for use by its new LTTs. At the time, their border defenses were still not completed, and the numbers of scout ships were not adequate to track down all possible incursions. This pod allowed an LTT to do the job. Like the regular scout pods of the fleet tug, this pod fell out of use after the Concordium's border defenses were completed, but after the failure of the Pacification campaign, the pod was placed back into service.

Special sensors are destroyed on "phaser" damage points.

SSD is in *Module R11*. Use any pod counter.

(R13.93) LIGHT HEAVY-FIGHTER RESUPPLY POD (P-LHF): Used to resupply the few carriers operating heavy fighters, since the existing FCRs could not handle them. These pods can carry fighters but cannot operate, land, refuel, or rearm them. The one shuttle bay was used to "warm up" replacement fighters, which could only launch once, and could not land. The bay did have ready racks and could fully arm the fighters before sending them on the way to their carriers. This type of pod can carry standard fighters (under the same restrictions) but cannot arm them via ready racks as the racks are for heavy fighters; they will have to use (J4.8962) and (J4.892). The shuttle bay includes an HTS to facilitate cargo transfer.

SSD is in *Module R11*. Use any pod counter.

(R13.94) LIGHT PF TRANSPORT POD (P-LPT): Able to carry a dozen PFs, this pod was used to ferry replacement PFs to front-line PF tenders. The pod could not operate, repair, refuel, or rearm PFs. Once the PFs were launched, they had to transfer to a regular PFT to begin operations. PFs launched from these pods will only have one crew unit and cannot carry more until they are serviced by a true PFT by having one repair point allocated to them by the PFT's repair systems.

SSD is in *Module R11*. Use any pod counter.

(R13.PF) ISC FAST PATROL SHIPS

(R1.PF7) WORKBOAT: With an economy that had not been ravaged by the General War, the ISC did not at first see a need to adopt the new small attack boats. Observations of their use by the Gorns and Romulans would eventually reverse that perception. Once the attack boats were in production, the ISC quickly saw the advantages of mass-producing workboats. During the Andromedan War, the ISC sold numbers of workboats to the Romulans and Gorns, and local shortages sometimes resulted in corporations operating on the edges of Concordium space purchasing spare workboats from other than Concordium sources. Records mention that isolated ISC cantonments, some of which voluntarily did not evacuate, survived in part due to the income made selling workboats, since each of the cantonment's FAST-BATS had a PF factory.

SSD is in *Module R11*. Use any PF counter.

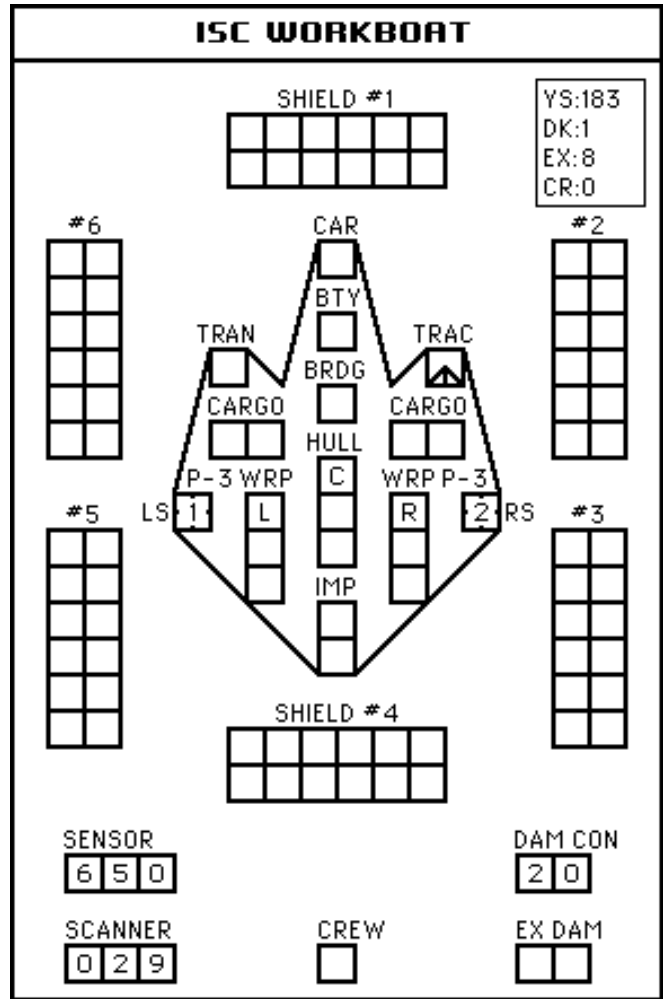

(R14.0) LYRAN DEMOCRATIC REPUBLIC

(R14.46) MILITARY POLICE TRANSPORT CORVETTE (MPT): While it would seem that the LDR did not need a “theater transport” (the entire LDR was smaller than most “theaters of war”), they in fact built one to carry Klingon-type cargo pods for peacetime trade with the Klingons and Lyrans. In theory, this would be available in wartime to rush critical supplies to an embattled border defense unit. The MPT served well until the LDR could afford to build a real LTT, at which time the crew of the MPT was transferred to the LTT and the valuable MPT hull was converted into a standard MP. Both ships were named *Commission*, confusing the records. The name of the MPT was changed when it was converted into a standard MP. While the LDR did not officially acquire its own Klingon pods until Y172, it is known that there were exchanges going on between the LDR and the Klingon Empire prior to that date, and between the LDR and the Lyran Empire which had acquired Klingon pods in Y165. These exchanges used Klingon and Lyran K-type pods technically owned by the Klingons and Lyrans respectively. Note that the SSD provides the data for both single-weight and double-weight pods, but any pods carried by this ship are inactive and every box in such a pod is treated as a “cargo” damage point.

UIM: Not available.

Refit: Data is conflicting as to the existence of this ship, but it doubtless would have had the ESG capacitor refit and would probably have had the plus refit installed in Y171. The Power pack refit would not have been installed as it would have prevented the ship from carrying any pods.

Known Ship Names: *Commission*.

SSD and counter are in *Module R11*.

(R14.47) LIGHT PF TENDER (MPP): The LDR was always looking for an edge in combat, and per capita had not just more ships, but more fighters and used more bombers than any other government. When interceptors were being developed, the LDR followed their development through their network of spies and “fellow travelers” within the Lyran Empire. Aware of plans to hang the new attack boats on ships, the LDR developed its own design (based on what it was learning about the Empire’s plans). The resulting design was a disaster. While it had looked good on paper, the LDR’s shipwrights and captains soon found that the MP hull was simply too small to operate interceptors, much less PFs. The ship design presented here is what it would have looked like had it proved an operational success (and if it had, no doubt every MP would have been fitted with mech links). Taking the lessons learned from this disaster, the LDR was able to find a way to operate a few PFs from their military police minesweepers, but the tradeoffs to do that would have resulted in virtually every MP having the same weapons array as the minesweeper.

The center section under construction for the MPP was scrapped, and the ship was eventually completed as an MPA.

Special sensor is destroyed on “torpedo” damage points.

UIM: Not available.

Refit: The original design included the plus refit. If the design had worked, a power pack would have probably been fitted in Y176.

Known Ship Names: None.

SSD and counter are in *Module R11*.

(R14.PF) LDR FAST PATROL SHIPS

(R1.PF7) WORKBOAT: The LDR gained PF technology from the Lyran Empire. It is known that they were given interceptors, and they purchased the right to build PFs under license. The LDR believed in being self-sufficient, and was soon producing its own PFs in some numbers. Even given the small size of LDR space, there was enough of a need that they were built to support the internal economy. Even so, workboats actually constituted the bulk of the PFs ever produced by the LDR. Most of the LDR’s workboat production was sold to the Lyran Empire, although after the General War they were also sold to the Hydrans. During the General War, the Hydrans complained about the LDR selling workboats to the Lyrans (since it was possible to convert a workboat into a combat PF, as the weapons and electronics are the largest expenses involved in building a PF). The LDR curtailed sales to the Coalition (at least officially) until the General War ended. (The LDR is thought to have sold workboats to Orion middlemen who then resold the boats at a profit to the Lyrans.) During the ISC Pacification and the Andromedan War, the LDR sold workboats to anyone who was willing to pay.

Unfortunately, the large numbers of workboats produced did not keep the Andromedans from destroying the LDR in Y195.

SSD is in *Module R11*. Use any PF counter.

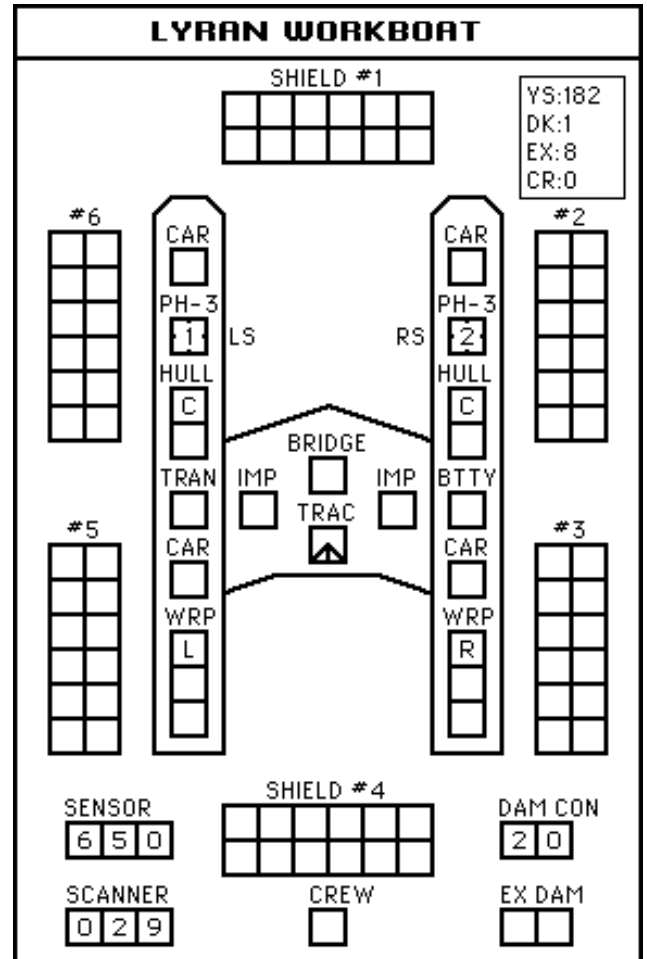

PERSPECTIVE: DIVISION CONTROL SHIPS

The cost and losses of wartime operations eventually forced the various empires into an attrition doctrine. The way had been shown by fighters and carriers, and these had been a steadily-increasing percentage of the combat power of each fleet during the first decade of the General War.

The appearance of fast heavy fighters increased this trend, as they had more firepower and, more importantly, improved survivability. (The original slow versions were actually less combat effective than standard fighters.) Across the galaxy, dozens of carriers converted to heavy fighters, more carriers were built specifically for them, and the survival rates of heavy fighters made them an increasingly important element of all combat fleets.

The rise of gunboats (also known as PFs, fast patrol ships, and even pseudo-fighters) put this trend into overdrive. If fast heavy fighters were 33% more effective than standard fighters, gunboats were 100% more effective, and no end of ships were converted to use them. PFTs on war cruiser hulls began to replace medium carriers in battle lines, and dreadnoughts were converted into monstrous space control ships as fast as possible. Patrol tenders put even more gunboats into battle zones. Fleets began to steadily grow, not from increased starship production but from decreased starship losses, as gunboats absorbed the punishment of increasingly brutal enemy fleet attacks (made more powerful by their own gunboats). Surprisingly, as fleet firepower climbed, fleet ship losses declined.

One aspect of this drive was the division control ship, which carried the largest attrition force that could be housed on a cruiser hull, albeit at the cost of their heavy weapons. (Dreadnoughts could, in theory, have carried more attrition units at the expense of their heavy weapons, but there were so few dreadnoughts that this was a path no empire chose to follow.) There was not physical space to dock more than six gunboats to a cruiser (or even dreadnought) hull, so the only way to put more attrition units on a ship was to use fighters. (The only ships that carried more PFs, the Kzinti SSCS and the Seltorian Hive Ship, were special cases.) It would in theory have been slightly more effective to combine gunboats and *heavy* fighters, but the production of heavy fighters could never keep up with demand to convert existing and new carriers, and the marginal improvement was denied to division control ships.

PERSPECTIVE: SCOUT PODS

Scout pods for tugs are one of those anomalies in the *Star Fleet Universe* which did not live up to the original concepts for their use. Tugs are rare, vulnerable, valuable, and over-tasked with important missions. Why any fleet planners thought they would be available for this mission is not easy to understand, but evidence indicates that such planners regarded any combat mission for a tug to be an emergency measure, and expected that scout pods were actually more likely to be used than carrier pods or battle pods.

Scout pods (along with the nearly-useless frigate-class scouts) were built during a time when nobody really understood what electronic warfare was going to be like in the cauldron of the General War. (This was not surprising. The Galaxy had not seen a war of that magnitude in many centuries, and none of the empires had any grasp of the concept. The Four Powers War had seen the birth of true electronic warfare, but the concept was not simply in its infancy; no one expected it to grow.) Frigate scouts were adequate to detect an enemy fleet and guide a fleet to intercept it, saving more valuable hulls for real combat missions. No one anticipated a need for scouts to stand in the line of battle and try to jam enemy fire control systems. No one had any idea of the hordes of drones and other seeking weapons that would be seen in fleet-sized battles of the General War.

Scout pods existed for many reasons, few of them well thought-out and none of them particularly valid in hindsight. At best, they were to be an emergency stopgap measure if it turned out that electronic warfare became a major element of combat operations. Should that turn out to be true, tugs with scout pods could hold the fleet for a year while new production and conversions of damaged ships in repair yards could provide true scouts. The tugs could then return to their primary missions.

There were other uses for scout pods. They were sometimes used for survey work, but proved more useful in doing pure scientific research than in finding new resources. They could be used for early warning and the tracking of enemy fleets, replacing destroyed bases. The Federation (in a move that must have been seen as absurd by the second year of the Klingon Invasion) actually planned to leave scout pods floating in space without tugs (or even move them with military freighter engines) as area surveillance and battle space control platforms.

(R15.0) SELTORIAN TRIBUNAL

(R15.35) DIVISION CONTROL SHIP: One Seltorian CA was built to this design in the very last days of the General War, entering service after it ended. It was used in several strikes against the Tholians but was eventually destroyed by the ISC.

Year	Escorts	Fighters
Y184+	CLE, DDE	12xZ-YC

Special sensors are destroyed on “torpedo” damage points.

This ship, despite being a carrier with drone-armed fighters, can only control a number of seeking weapons equal to half its sensor rating.

Known Ship Names: *Cold Wind of Revenge*.
SSD and counter are in *Module R11*.

(R15.36) NEW HEAVY SCOUT CRUISER (NSC): Electronic warfare had not been perceived as a major factor in combat in the Tholian Home Galaxy. While special sensors existed, the use of Tholian web casters had largely negated the ability of enemy fleets to use them effectively. After the conquest, the Tholian perception of the weakness of electronic warfare in combat had come to dominate their military thinking. This thinking had in turn been inculcated into their Seltorian enforcers. Combat in the Milky Way Galaxy proved far different. The Holdfast Tholians adapted to the use of electronic warfare in the absence of web casters. The Seltorians were given a rude shock, and were slow (despite Klingon warnings) to see the need for large scouts to support their operations against the Tholians. By Y185, it had become clear to the Seltorian Sages that the scout destroyer was simply not powerful enough, and a larger mobile electronic warfare platform was needed. The records are not clear if this particular ship was built. It is known that the Seltorians did build at least one larger scout and that it did take part in several actions. It is not clear if it was based on the new heavy cruiser, or if it was simply a light cruiser, or if the Seltorians converted a light cruiser scout into this design before the ISC attacked their base in Klingon space. The design would have been an excellent electronic warfare platform, in part because the lack of web breakers indicated the decision by the Seltorian Sages to have the ship operate only in that role.

Special sensors are destroyed on “torpedo” damage points.

Known Ship Names: *Sea of Dread Prophecy*.
SSD and counter are in *Module R11*.

(R15.37) NEW LIGHT SCOUT CRUISER (CLS): Records indicate that the Seltorians built one large scout ship. It may have been a light cruiser scout, or it may have been based on the new heavy cruiser design, or they may have built this ship and then converted it. The ship would have been more effective than the destroyer scout, if only because it had more power to use. The design retained the web breakers to use in assisting a fleet in cracking the outer webs of a Tholian base whose defending forces were weak. This was considered important, as the longer it took to reduce such a web, the more likely it was that Tholian reinforcements would arrive.

Special sensors are destroyed on “torpedo” damage points.

Known Ship Names: *River of Liquid Silver*.
SSD and counter are in *Module R11*.

(R15.38) LIGHT PF TENDER (DDP): The Klingons warned the Seltorians of Tholian PFs and tried to convince them to

use PFs that they could provide. The Seltorian Sages saw this as an effort to make them dependent on the Klingons for something, and chose instead to build their own. Even with Klingon engineers offering the designs for collapsible repair bays the Seltorians went the internal bay route because they believed their experience with the operations of a hive ship would help them make it effective. The design was in many ways different from the light PF tenders of most races, in that it was able to flush the ion engine buildup of PFs docked to any station. The Seltorians soon learned, however, that the ship needed to be out of combat to dock PFs internally in order to repair them and replace their warp packs. It may be the problems they had with this ship that led them to ask the Klingons for the advice that eventually led to the DNL design. The records show that the Seltorians built only one ship of this type, but in the chaos of the Seltorians’ annihilation it is not clear what happened to the ship. It is presumed that it was destroyed either by the ISC or the Klingons, although the Tholians claim they destroyed it in a raid a year earlier.

Special sensor is destroyed on “torpedo” damage points.
Known Ship Names: *Mountain of Iron Ingots*.
SSD and counter are in *Module R11*.

(R15.PF) SELTORIAN TRIBUNAL FAST PATROL SHIPS

(R1.PF7) WORKBOAT: The Seltorian workboat is a curious anomaly in that the Seltorians clearly did not need such a boat. Cargo PFs were quite adequate for bringing up goods from the planet the Klingons were letting them use, and lone Seltorians had no business operating workboats away from the Hive Ship. Still, the Seltorians built a few dozen of them, and after the Hive Ship was destroyed, the workboats became highly prized wherever they were found. The Seltorians may not have been exceptionally imaginative ship designers, but their workboats were well built and among the best in known space, with at least four still being in service in Y200.

SSD is in *Module R11*. Use any PF counter.

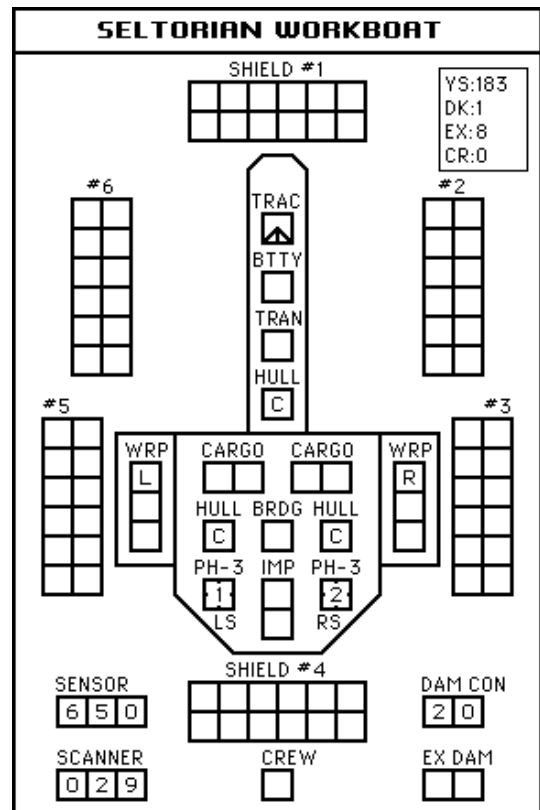

(R16.0) JINDARIAN CARAVANS

(R16.PF) JINDARIAN CARAVANS FAST PATROL SHIPS

(R1.PF7) WORKBOAT: The Jindarian Caravans began producing workboats almost as the first PFs they built. Every caravan found workboats to be highly useful in their mining operations, and used them to scout neighboring systems for asteroid clusters. Most, but not all, caravans sold excess workboat production to the local races. The availability of Jindarian workboats drove the various empires' security services to distraction. Many considered the invention of the workboat one of the worst things that had happened from the standpoint of controlling the flow of enemy agents (or citizens seeking asylum in a neighboring race's territory, or doing a little cross border smuggling). The Jindarian workboat, despite its massive availability, was not very popular as it was more cramped internally than the workboats of other races. Still, they were available and that counted for a lot for a young adventurer hoping to make a fortune.

SSD is in *Module R11*. Use any PF counter.

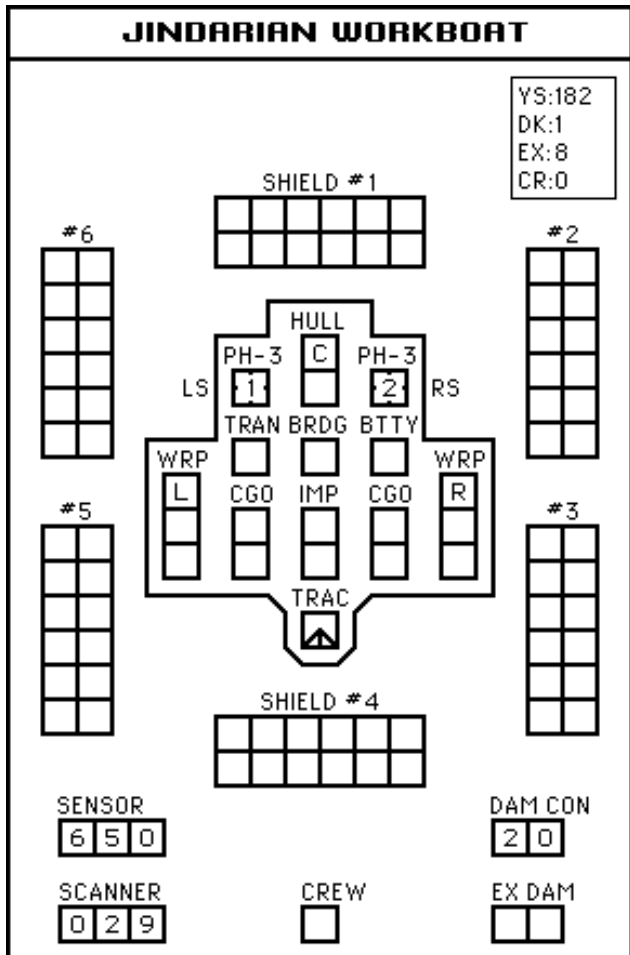

PERSPECTIVE: FAST RAIDERS

Before the General War began, all empires had built a number of fast warships for expected raids deep behind enemy lines. Most were based on heavy cruiser and dreadnought hulls, and a very few were built on smaller hulls. It was assumed that the smaller hulls could not survive behind enemy lines except as part of larger raiding groups, and limited budgets meant that all fleets concentrated on the larger raiders intended for solo missions.

As the General War developed, more and more of the original raiders were lost on missions, and the need for mass wartime construction left few resources available to build more of the larger types of raiders. Those admirals and staff officers who supported the raiding mission pressed for more ships of their special types, but most empires had "gone sour" on the raiding idea, considering the loss rates too high for ships that spent most of their time waiting for a target. It was better, most thought, to build standard warships and use them (and their superior firepower) continually. While this meant fewer raids would be conducted, the odds of success were low enough that there was no guarantee any given raid would be worth the risk. Military planners could not count on a raid to "open the door" for a major operation, because if the raid failed, the major operation would have to be cancelled. This meant raids were merely a matter of picking off targets of opportunity (convoys and fleet repair docks), the destruction of which had a minor "general" effect but did not unhinge entire enemy fleets.

As the General War continued, however, the lack of raiders was felt in other ways. Fast warships had always been important in reserve units, and had become increasingly important in pursuing crippled enemy ships retreating from major battles. While the value of raids was debatable, the lack of any ability to conduct raids eliminated some tactical options for theater commanders. The various empires began building fast raider versions of war cruisers (seen in this product) and of other ships (in future products), primarily for these missions. More new war cruiser hulls were available, and it was less troublesome to divert one to be transformed into a raider than to give up a far more valuable heavy cruiser. Some of these light raider cruisers did, in fact, get used for raids, often in groups of two or three.

(R17.0) VUDAR ENCLAVE

(R17.37) DIVISION CONTROL SHIP (DCS): The Vudar never had enough hulls available to build every kind of ship. When X-technology became available, they chose to convert what ships they could to that rather than divert scarce hulls to carrying attrition units. The ship presented here is a best guess at what a division control ship converted from a Vudar command cruiser would have looked like.

Year	Escorts	Fighters
Y185+	CWA, DWA	11xElectron, 1xTachyon

Special sensors are destroyed on “torpedo” damage points.

Known Ship Names: None, conjectural ship.
SSD and counter are in *Module R11*.

(R17.38) LIGHT PF TENDER (DWP): When the Vudar began designing their own PF tenders, they started by questioning those members of their race who had served aboard Klingon PFTs. Unfortunately, the experiences of these beings was very limited, the Klingon Empire being extremely compartmentalized. Not having access to what the Lyrans were doing, the Vudar initially went down the same route as every other empire when designing its first patrol boat tender: a war destroyer with a large hole cut in to allow a PF to dock internally for repairs. The Vudar actually built only one ship of this class, and it was lost in action in a duel with a Hydran DWP in Y184. Other PF tenders were built to the design seen in Module F2 (R17.25) and were also designated DWP.

Special sensor is destroyed on “torpedo” damage points.
Known Ship Names: *Firebolt*.
SSD and a counter are in *Module R11*.

(R17.PF) VUDAR ENCLAVE FAST PATROL SHIPS

(R1.PF7) WORKBOAT: The Vudar built very few workboats during the waning days of the General War. Matters did not get much better during the ISC Pacification as the ISC showed little interest in trying to protect the Enclave from the Klingon Empire (as opposed to keeping the Enclave and the Hydran Kingdom from fighting). The ISC seemed to regard the LDR and Vudar as “internal matters” of their respective empires. Or perhaps they were biding their time to gather the forces needed when the Andromedans interrupted their plans. (After all, the ISC had eliminated the Seltorians, but had not gotten involved in the Romulan or Kzinti civil wars either.) During the period of the Pacification, however, the production of workboats did increase as the Klingons were not as interested in causing the Vudar trouble as they were in getting their own internal house in order. By the time the Andromedans attacked, the Vudar were selling workboats to the Klingons and Hydrans, and even sold some to the ISC. Local Vudar commanders, in order to better exploit resources to strengthen the Enclave against external attack, purchased additional workboats from the Jindarians, and when they were available, from the ISC, Klingons, Hydrans, and Orions. Vudar workboats were not particularly favored by non-Vudars as the new owners were never certain they had eliminated the tendency for the impulse engine to leak ionizing radiation. Conversely, Vudar operating in non-Vudar designed workboats were always concerned that they were not getting enough ionized radiation to keep themselves healthy.

SSD is in *Module R11*. Use any PF counter.

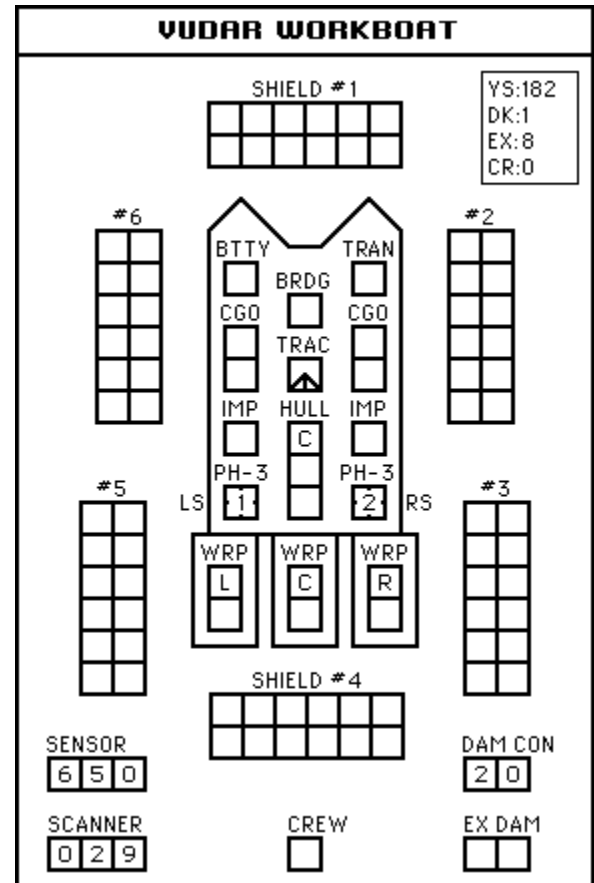

PERSPECTIVE: WORKBOATS

From Y100 (and even before that), major planets and colonies of all sizes had used a wide variety of shuttles, converted freighters, and small ships of no end of types and sub-types to support space operations (mostly mining on asteroids and uninhabited planets). Such “craft” were used by explorers and miners, by those who picked up the production from the mines and dropped off supplies, and by traders and merchants of all sorts who worked in limited regions. While Free Traders, converted freighters, and Priority Transports were the largest of these ships (and could better be considered as “ships” than “craft”), the vast numbers were shuttles and (from Y140 onward) skiffs.

Naval authorities had taken to collectively grouping these “craft” into the loose category of “boats”, and a starship commander might ask his tactical intelligence officer to track all of the “boats” in the star system he was entering. (This might have been a considerable task, as a colony could easily have over a hundred shuttles and skiffs operating in its system.)

Skiffs (there were at least a dozen types, of which the Seeker and Modular Cutter were the most common, amounting to 25% of the total each) had proven more effective than shuttles, but being more expensive, were used only by governments, major corporations, and those private explorers and traders who could afford them. Skiffs paid for themselves in doing missions that shuttles could not undertake and for which the larger “ships” were too expensive to use. Skiffs were faster, had longer range, and could remain longer in unsupported areas as they carried more fuel and supplies. Skiffs had things shuttles did not have: airlocks, transporters, tractor beams, and sometimes even a shuttlecraft.

Production of skiffs was a part of the civilian economy of each empire. Skiffs existed because they made money for the

owners, and there was a steady (even expanding) market for them in the accelerating search for new resources to feed the wartime economies. More and more colonies increased their police forces with additional skiffs, the only “combat craft” available other than fighters. Production of skiffs doubled between Y165 and Y175 as the need for such ships expanded. Raiding cruisers considered colonial police skiffs to be “targets of opportunity” as they were easily destroyed with a single volley, and their loss created financial and other problems for the colonies that operated them.

The development of interceptors and gunboats grew out of existing skiff technology. Everyone had known for a decade how to put larger engines on skiffs (although this required new designs as the Security and Modular Cutter types could not handle more power or mount additional systems to use that power), but to build a combat-capable skiff required relatively gigantic engines, something possible only by adding dangerous warp booster packs to the largest engines a skiff-category “craft” could handle. Interceptors and the later gunboats were built in factories that had been building skiffs for decades, although once the true role, missions, and value of gunboats were known, existing skiff factories were turning out gunboats at maximum production and more new factories were built.

This starved the skiff market. There was always a need for more skiffs, for use as police boats and mining/exploration craft, and to replace normal attrition and losses from wartime raids. The sudden demand for massive gunboat production left those who wanted skiffs going without. The forces of the marketplace could not respond to the crying need for more skiffs as wartime priorities had to be on combat craft. The development of X-technology and its need for new resources that could be found on previously-ignored worlds also created a demand for more skiffs.

Most empires reached a turning point within two or three years of gunboat development. Full gunboat deployment had been completed, meaning new production was required to maintain, not increase, gunboat strength). Gunboat production had increased to cover the loss rate. Most importantly, the need for more skiffs (simply to replace those that were lost in accidents or raids or worn out, let alone demand for additional ones to find resources for X-technology) had reached a crisis point. The result was the workboat, a gunboat modified for “civilian” use. The design was a much-simplified version of the cargo PF, with only a couple of phaser-3s for defense, a much smaller crew, larger fuel tanks, non-combat systems (tractor beams, airlocks, transporters, and often a shuttlecraft), and somewhat more comfortable quarters. (Workboat crews would live on their craft for weeks, rather than flying them only on combat patrols from the bases where military crews lived.) Without the troublesome warp booster packs, workboats had vastly extended range and endurance (and no build-up of ionic charges in their engines), but of course, far less combat capability. A small percentage of gunboat production diverted to workboats fulfilled the valid economic need for new skiffs. Because gunboats were mass-produced in huge numbers, workboats could be made more cheaply than skiffs.

The Federation never built gunboats, so it never stopped building skiffs, and thus never had the “skiff shortage” of other races. In fact, the Federation sold skiffs during the General War to the Kzintis and Gorns.

There were also gunboat variants produced for police use (with lower-grade weapons, smaller crews, tractor beams, transporters, and other changes), and for survey use, but these are in other products.

Workboats had one major advantage over the earlier skiffs: they could be carried on mech links. Skiffs had never been designed with this in mind, and once mech links were

invented for interceptors and gunboats, attempts to modify existing skiffs or skiff designs to put them on mech links proved impossible. Building a skiff that could survive on a mech link meant building a gunboat, not a skiff. Mining ships that had carried prospecting shuttles now found they could carry a workboat on a mech link, and such a workboat was able to support (and if necessary rescue) the smaller prospecting shuttles.

When the General War ended, the need for new resources (and the availability of thousands of war-surplus gunboats) produced an explosion in workboat production, mostly by converting existing combat ships to the “civilian” versions.

The need for these new resources (and the relatively easy ability to find them given a suitable spacecraft in which to seek them) gave rise to a new class of fiercely independent explorer-prospectors. Most of them were ex-military, and veterans of gunboat campaigns that had seen crews become closer than blood relatives. They lived a good life, and many even became wealthy (with a few lucky finds). Having been treated as expendable cannon fodder by their governments, their loyalty was to each other, not to any empire.

Workboats had far more range than shuttles (and somewhat more range than skiffs) and their vast numbers could not be adequately counted, let alone controlled. Pre-war base and sensor networks were no longer available to keep track of traffic across the borders, and everyone was tired of war anyway. While workboats may have been a security issue (as it was possible for millions of “illegal immigrants” and dozens of spies and terrorists to cross the border), they were hardly a military threat.

War surplus (and new production) workboats were sold to anyone with cash, and the Federation became a gigantic black hole of a workboat market since there were no Federation gunboats to convert, and the Federation had the most money to pay successful explorer-miners. Federation citizens who bought workboats remained somewhat more loyal to the Federation, having missed the experience of being treated as expendable. Foreigners who brought their workboats into the Federation tended to become loyal inhabitants of the Federation because of the good money to be made and the great personal freedom they found. The Federation had a great tradition of welcoming those with initiative, self-motivation, and the desire to gain and hold the fruits of their own labors. Workboats were, unfortunately, used to bring economically-desperate subject-race people from the Klingon Empire and Kzinti Hegemony into the Federation, looking for menial ground-side jobs. Interceptors were not sold off to the skiff market, as front line units kept theirs until they got gunboats, and then sent the last interceptors to the gunboat training units (which had been greatly expanded to fill the requirements of the fleet). After the General War, there were still hundreds of interceptors in operation, many of which had been converted into “utility boats” by military units with most of their weapons removed. Some of these were sold off into the civilian market.

Other empires had more, or less, trouble with border-crossing adventurers. The security concerns drove the Klingons, Kzintis, and Romulans to a point near insanity, and they finally had to establish “interior” borders a thousand parsecs from the Neutral Zone beyond which permits and tracking devices were required for anyone seeking entry. While workboats had more range than shuttles, they lacked enough range to operate that far from their bases, and the smaller number of foreign-built and foreign-owned workboats seeking deeper entry into these security-conscious empires made managing them a possible (but not easy) task.

(SG85.0) FALSE ECONOMICS

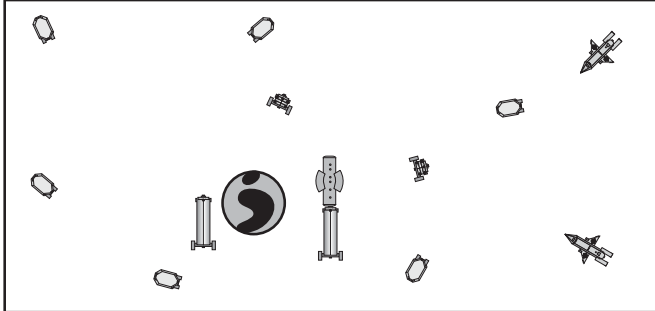

by Steven Paul Petrick, Texas

During the ebb and flow of the General War, the ISC pacification, and the Andromedan War, many small colonies had most of their existing defenses destroyed. In some cases, a colony would surrender without a fight when an invading fleet appeared. When occupying forces withdrew, they would often destroy the defenses of any such surrendered colony in an effort to tie down enemy ships to defend them. The result was numbers of colonies in various border areas that were relatively undefended. In the waning days of the General War, many of these small colonies chose to not rebuild any significant defense, but to work on their own economic recovery. More than a few continued with this attitude well into the Andromedan War.

Almost all of them acquired *some* defenses, if for no other reason than for the wealthier members of the colony (or the major stockholders outside of the colony) to claim that the defenses were adequate. This allowed more wealth to accrue, since it was not being wasted on things like new DefSats (when a weather/transporter repeater satellite was adequate), or ground-based defense phaser stations, or even fighters. (Just think of all the money saved by not paying people to wear uniforms and lounge around all day!) Instead, money could be spent on more useful things, like a commercial platform to facilitate the movement of the colony's production into the larger economy, or workboats to help find useful minerals and other materials within the system.

Far too often this eventually led to the consequences that befall all ill-guarded wealth.

(SG85.1) NUMBER OF PLAYERS: 2; the Colony player and the Raider player.

(SG85.2) INITIAL SET UP

TERRAIN: Class M planet in hex 2215.

COLONY: Commercial platform with 2x cargo augmentation modules in standard orbit. The Colony player chooses the orbital radius, and rotation rate, but the Raider player chooses, within the allowed hexes of the orbital radius, the starting hex for the platform. This reflects the raider planning his arrival.

CSOB, GSA, and GMS in hex 2215/2214.

Six workboats (see SG85.45).

One small freighter docked to the Commercial Platform.

One small freighter in standard radius one orbit (P8.0).

Two local defense freighters [see (SG85.46)].

The Colony has three satellites in a standard radius-1 orbit, but the only game function of these satellites is as transporter repeaters (R1.15H). These set up in hexes adjacent to the planet.

See (SG85.47) for weapons status.

RAIDER: One or more ships of size class 4 of a combined combat BPV of no more than 150 points, enter from any map edge, heading at the player's option, speed max, WS-III. See (SG85.48).

YEAR: Players should select a year before setting up the scenario. This will define the availability of ships, refits, fighters, drone speeds, and other items. Y184 is assumed if no other year is selected.

(SG85.3) LENGTH OF SCENARIO: The scenario continues until all forces belonging to one side have been destroyed, captured, have disengaged, or until the end of Turn #10.

(SG85.4) SPECIAL RULES

(SG85.41) MAP: The map is fixed; it does not float. Any unit leaving the map has disengaged and cannot return. All units can disengage from any map edge.

(SG85.42) SHUTTLES AND PFs: All Raider shuttles and PFs have warp booster packs, and all Raider shuttles are advanced types if the year selected allows their use. Colony shuttles will not be improved types or have warp booster packs.

(SG85.421) MRS shuttles may be purchased [up to the limits in (J8.5)] under (SG85.431).

(SG85.422) If using EW fighters, use the standard deployment patterns (one EWF for each squadron of eight or more fighters) for EW fighters.

(SG85.423) PFs may appear in this scenario if used by the Raider player. Such PFs can generally be of any type except leader or scout variants, multi-role variants, or Hydran Howlers. PFs should be consistent with the empire of the raider player, e.g., a Harrier used by a Hydran raider.

(SG85.43) COMMANDER'S OPTION ITEMS

(SG85.431) Each Raider ship can purchase additional or special equipment as Commander's Option Items (e.g., T-bombs, extra marines, etc.) up to 20% of its Combat BPV. Colony units cannot use Commander's Options.

(SG85.432) Drone speeds will depend on the year selected for the scenario.

Each drone-armed Raider ship can purchase special drones up to the historical racial percentages as part of the Commander's Option Items. Drone-armed Colony ships will only have type-I drones of the generally available speed. Note that (S3.2) allows drone ships extra points for this purpose.

(SG85.433) If players wish to use the optional rules for Prime Teams (G32.0), the Raider player may have one such team while the Colony player can be given 25 Commander's Option Points to distribute among his forces as desired or to purchase additional units, but not a Prime Team of their own.

(SG85.44) REFITS are available depending on the year selected.

(SG85.45) WORKBOATS: The colony has six workboats. The locations of the workboats are not predictable and they could be anywhere in the system at the time the Raider begins his attack. After the Raider player indicates the location of the ComPlat, for each workboat roll a die with the following results:

- 1 Workboat begins scenario landed at the CSOB
 - 2 Workboat begins scenario docked to the ComPlat
 - 3 Workboat begins scenario docked to the orbiting freighter
 - 4 Workboat begins scenario anywhere within four hexes of hex 2215
 - 5 Workboat begins scenario anywhere within ten hexes, but no closer than five hexes, of hex 2215
 - 6 Workboat sets up anywhere at the player's option
- Workboats that begin the scenario under die rolls 4-6 can have any heading and are at speed 10. Any crippled workboat must attempt to disengage and cannot take any

action against the Raider. Note that a colony might well have dozens of shuttles and workboats all over an area a billion miles across and the ones in this scenario are simply those near the planet and hence relevant to an attack on it. (They are also easier to find and steal all at once than finding individual workboats scattered all over the asteroid-belt).

(SG85.46) LOCAL DEFENSE FREIGHTERS: These are old small freighters that have are using skids in place of their cargo pods. Use a Small fFreighter front and back end, and each has the following skids:

Freighter #1: 1xCCS, 1xSDS-1, 1xSDS-3.

Freighter #2: 2xSDS-2, 1xSDS-3.

The self-defense freighters are set up after the Raider player selects the starting hex of the ComPlat. Facing is at the option of the Colony player, speed 3.

(SG85.47) COLONY WEAPON STATUS: The Raider is not going to know if his approach has been detected. It would be best for him to assume that the Colony is prepared for his arrival, but the truth is that he may have achieved tactical surprise. Before Energy Allocation on Turn #1, the Colony player draws a chit from a cup of chits numbered from one to six and compares the drawn chit to the following chart:

- 1 Weapon Status 0
- 2 Weapon Status 0
- 3 Weapon Status I
- 4 Weapon Status I
- 5 Weapon Status II
- 6 Weapon Status III

Set the chit aside where the Raider Player can examine it after the scenario has ended.

The Colony cannot call up militia (D15.83), but the two small freighters can form defending militia on their control spaces normally (D16.522).

(SG85.48) RAIDER BPV: The Raider purchases his ship(s) at Combat BPV. The BPV does not include the cost of any Commander's Option Points, but does include the costs of any drone speed upgrades that are not themselves Commander's Option Items (transition years). The Raider must purchase his ship(s) and other units BEFORE consulting the objective table in (SG85.49), but purchases his Commander's Options AFTER consulting (SG85.49). In this way his ship may not be best suited to his actual mission and he may have to try to make up for it through his Commander's Options.

(SG85.49) RAIDER OBJECTIVE: The Raider player is generally trying to accomplish something, and this something will not necessarily be known to the Colony. After the Raider player has purchased his ship(s), he draws a chit from a cup of chits numbered from one to six and consults the following table:

- 1 Transfer 100 spaces of cargo from the CSOB to his ship(s).
- 2 Transfer 150 spaces of cargo from the ComPlat to his ship(s).
- 3 Transfer 150 spaces of cargo from one of the two freighters to his ship(s). In this case determine randomly which of the two small freighters is the target ship.
- 4 Transfer 50 spaces of cargo from the Agricultural Station and 50 spaces of cargo from the Mining Station to his ship(s).
- 5 Capture three of the workboats and disengage them (this includes tractoring the workboat and dragging it off the map, not necessarily boarding and capturing it). Workboats only count in this case if they still have at least one undamaged cargo box remaining when they exit the map, the Colony player cannot fire on his own workboats for any reason.
- 6 Destroy all three ground bases and the ComPlat.

If the Raider's mission is to capture cargo, he does not need cargo boxes to accomplish this, and if he has cargo boxes, the destruction of his cargo boxes does not result in his having lost the scenario. Place the chit drawn where the Colony player can examine it at the end of the scenario to confirm the Raider's objective.

(SG85.5) VICTORY CONDITIONS: The Raider wins if he accomplishes his objective and successfully disengages his ship(s) uncrippled. If the Raider has more than one ship, the scenario is a draw if he accomplishes his objective but one of his ships is crippled, destroyed, or captured.

The Colony player wins if the Raider fails to accomplish his objective.

(SG85.6) VARIATIONS: The scenario can be played again under different conditions by making one or more of the following changes:

(SG85.61) Set the scenario earlier, and replace the workboats with two Seeker skiffs and four modular couriers equipped to move cargo.

(SG85.62) Add a third player who is Raiding the Colony at the same time. This player has the same objective as the first player, but only one of them can win. If the objective is to transfer 150 spaces of cargo from the ComPlat the fact that the ComPlat has far more than 150 spaces is irrelevant, it is the specific 150 spaces that both Raiders want.

(SG85.63) For a larger battle, increase the BPV of the Raider to 150 points and change the two defending freighters to large freighters:

Freighter #1: CCS, 1xSDS-1, 2xSDS-2, and 2xSDS-3

Freighter #2: 2xSDS-1, 2xSDS-2, and 2xSDS-3.

Change the CSOB to a CPOB.

(SG85.7) BALANCE: The scenario can be balanced between players of different skill levels by one or more of the following:

(SG85.71) Change one or more of the workboats to cargo PFs.

(SG85.72) Allow the Colony player to use Commander's Option points for some of his units.

(SG85.73) Add a standard combat PF to the Colony's forces.

(SG85.8) TACTICS

RAIDER: Your tactics are going to be defined by the ship(s) you chose and the mission you draw. It might be nice to just buy three or four combat PFs and come in with guns blazing, but you will lack the boarding parties needed to win a fight to capture anything. It is not guaranteed that you will need a lot of boarding parties; drawing mission #6 would be relatively simple and does not require marines. Look for opportunities to confuse the Colony about what your mission is. Pounding the ComPlat with heavy weapons while crippling and tractoring a workboat and boarding a second could divide his forces since he will not know if your objective is #6 or #5, and it might be #3. If your ship cannot land, make sure it at least has a good number of transporters to get the troops down as quickly as possible to capture the objective.

COLONY: Don't you wish the Colony had sprung for at least a ring of real DefSats? You are massively out-gunned, and all you are trying to accomplish is to convince the raiders that, even though you do not have a "real" defense force, you are a tough nut to crack. Maybe they will think twice about raiding you in the future, and maybe the colony's government will give more thought to its defense. You have 24 boarding parties available, but they are spread all over the place and you do not know where you will need them (or even if you will need them).

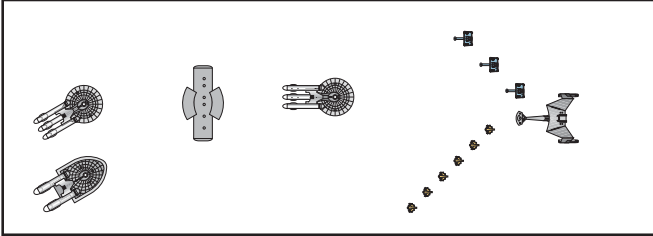
(SH240.0) AN URGENT MATTER**(Y182)**

by Steven Paul Petrick, Texas

In Y182, a Romulan agent scored a massive intelligence coup by acquiring a complete copy of the plans for a massive Alliance Offensive to be directed against the Klingon Empire. The information was not immediately useful to the Romulan Star Empire (other than that it indicated the Alliance would not be aiming its main offensive operation for the year against the Romulans), but could materially aid the Empire if the Klingons were able to use the information to crush the offensive. The agent knew that he had to get the plans into the hands of the Klingons.

Unfortunately, the file was too large to be sent by normal means, and the agent, being a Romulan, did not have access to secure codes to transmit the information to the Klingons. Transmitting the information through normal channels to the Romulan Empire would get the information into the hands of the Klingons, but too late for the Klingons to take advantage of it, as the offensive was about to start.

With time short, the Romulan agent broke cover, and caught transport heading towards the Klingon front, gambling that there would be sufficient delay and confusion of his trail that he would have enough of a head start to effectively disappear until he reached Klingon-held space.

It proved a good gamble, and he almost made it.

Unfortunately, the connections he had to rely on to successfully complete his transit were not ones that had been established by the Empire, but ones he was improvising, and they fell through. He arrived at communications relay station GX-2011-Gamma posing as a repair technician, only to learn (from local gossip) that a skiff carrying two G1A agents was due to dock in less than an hour. He also learned that a free trader (to which he was to transfer) had been ordered to divert away from the station.

Realizing the import of these things, the agent seized an administrative shuttle and programmed its small subspace radio to broadcast, in the clear, that he was present at the station, and that he had concealed the data file. The approaching skiff promptly blew the shuttle apart.

The Klingons, who had been apprised by the Romulan Empire that the agent was en route and carrying the data file, realized the value of what the agent was carrying. They ordered the UD7 *Deathmaster*, which was nearest unit they had to the station, to recover the data file at all costs, and the agent if possible.

The *Deathmaster* broke through the Federation front and drove on the station.

The Federation, caught off guard by the sudden attack in a relatively quiet sector, ordered the nearest ships to respond. The plans had to be recovered, or the offensive would have to be called off.

(SH240.1) NUMBER OF PLAYERS: 2; the Federation player and the Klingon player.

(SH240.2) INITIAL SET UP

FEDERATION: Communications Relay Station GX-2011-Gamma in hex 2215, initial facing and rotation rate at the player's option, WS-III. See (SH240.45).

DW *Taylor*, Skiff #129, set up anywhere with five hexes of the station, initial heading at the player's option, speed 10, WS-III.

Reinforcements: NLF *Simon Bolivar* arrives on Turn #2, heading determined randomly, speed max, WS-III. See (SH240.461).

ADW *Pulaski* (3xF-111) and FFA+ *Mohammad Allam* arrives on Turn #3, heading at the player's option, speed max, WS-III. See (SH240.462).

KLINGON: UD7 *Deathmaster* (6xZ-YB, 3xG1) enters the map anywhere along the 01xx map edge, heading B or C, speed max, WS-III. See (SH240.47).

(SH240.3) LENGTH OF SCENARIO: The scenario continues until all forces belonging to one side have been destroyed, captured, have disengaged, or until the end of Turn #10.

(SH240.4) SPECIAL RULES

(SH240.41) MAP: Use a semi-floating map. Any unit that moves in such a way as to force the communications relay station off the map has disengaged and cannot return. (That is, the unit, not the relay station, is removed.) The Klingon units can disengage by leaving the map in directions E or F (inclusive). The Federation units can disengage by leaving the map in directions A, B, C, or D (inclusive). Units which disengage by acceleration must be facing in an authorized direction to do so safely. Units which disengage by leaving the map can have any facing at the instant of doing so. Units which disengage in unauthorized directions are considered destroyed.

(SH240.42) SHUTTLES AND PFs: All shuttles and PFs have warp booster packs and are advanced types. No fighters have warp booster packs. The F-111s on the *Pulaski* all have megapacks, but no other fighter has megapacks.

(SH240.421) MRS: Historically no unit involved in this action had an MRS at the time it was fought. MRS shuttles may not be purchased by any unit.

(SH240.422) If using EW fighters, one of the six Z-YBs on the *Deathmaster* is a Z-YE. If not using EW fighters, it is a standard Z-YB.

(SH240.423) The three PFs available to the *Deathmaster* are the remnants of its PF flotilla, and are considered a single flotilla for all purposes, i.e., the *Deathmaster* can generate EW points that are simultaneously lent to each PF. They are otherwise standard G1s, not leaders or scouts.

(SH240.43) COMMANDER'S OPTION ITEMS

(SH240.431) Each ship can purchase additional or special equipment as Commander's Option Items (e.g., T-bombs, extra marines, etc.) up to 20% of its Combat BPV. See (S3.2) for details and exceptions.

(SH240.432) All drones are "fast," i.e., speed-32.

Each drone-armed ship can purchase special drones up to the historical racial percentages as part of the Commander's Option Items. Note that (S3.2) allows drone ships extra points for this purpose.

(SH240.433) Prime Teams (G32.0) are not available in this scenario.

(SH240.44) REFITS: The *Mohammad Allam* has the plus and Y175 refits. No other unit involved in this action has received any refit.

(SH240.45) COMMUNICATIONS RELAY STATION: The Klingons are attempting to recover a vital data file that is hidden on the station.

(SH240.451) To secure the data file the Klingons must place at least ten boarding parties on the station and have at least one boarding party survive at the end of three consecutive turns, e.g., from Impulse #16 of Turn #4 to Impulse #15 of Turn #7, and be recovered. The

counting procedure begins when the tenth Klingon boarding party is placed aboard the station, irrespective of whether or not there are fewer than ten boarding parties aboard the station at that moment due to casualties. The surviving boarding party need not have been one of the first ones placed on the station, but if no Klingon boarding parties have survived at the end of one of the boarding party combat stages, the data file is not recovered.

(SH240.452) The station cannot purchase anything, not even extra boarding parties, as Commander's Options. The station only has one shuttle. The station cannot voluntarily lower shields that are facing the Klingons, including Klingon drones, for any reason; this includes reducing the shields to minimal status. Shields not facing Klingon units can be lowered to allow Federation boarding parties to be beamed over.

(SH240.453) The obvious solution for the Federation would be to blow the station up, but the Federation cannot do this as they cannot rescue all the Federation citizens on the station.

(SH240.454) The Klingons may blow the station up at their option if they have failed to recover the data file (reflecting their frustration, but this will not gain them any advantage, and will incur the umbrage of enlightened galactic society). They can otherwise only fire on it enough to drop shields. If the station takes more than ten points of internal damage as a result of Klingon weapons fire, the data file is destroyed.

(SH240.455) The drone racks on the station can be loaded with type-IF drones or ADDs at the Federation player's option. There are no special drones or type-IV drones. The station may only fire its phasers (or launch drones) at Klingon drones. It cannot fire at any other Klingon unit. Regardless of their target, it may engage any Klingon drone.

(SH240.456) The Federation cannot beam boarding parties onto the station until the turn after the turn the Klingons first transport boarding parties aboard it, i.e., if the Klingons put boarding parties on the station during Turn #3 the Federation cannot transport boarding parties aboard it until Turn #4.

(SH240.457) None of the crew units on the station can be converted to militia. None of the Federation ships may begin the scenario with militia squads formed, nor begin forming militia until the Klingons board the station.

(SH240.46) FEDERATION REINFORCEMENTS arrive as follows:

(SH240.461) Before Energy Allocation on Turn #2 the Federation Player announces a unit, whether a Federation unit or a Klingon unit, and then rolls a die and consults the directional arrows in hex 0328. The *Bolivar* will enter the map through the edge of the map hex in the indicated direction from the selected unit. Example, the Federation player chooses a Klingon fighter in hex 0812 and rolls a two indicating the *Bolivar* enters the map through hex 3101. The *Bolivar* must be heading directly towards the selected unit when it first appears.

(SH240.462) Before the scenario begins the Federation player must record the direction from which the *Pulaski* will enter the map. At the start of Turn #3, before Energy Allocation, this record is revealed. The *Pulaski* is placed in a hex 36 hexes away from the CCS but no closer than 15 hexes to the nearest Klingon ship, shuttle/fighter, or PF. The *Mohammad Allam* can be placed in any adjacent hex, or the same hex. The F-111s are fully armed and may begin the scenario either launched or aboard the *Pulaski* in any combination. The Federation player chooses their status (one launched and two not

launched, all launched, etc.) in writing before the scenario begins.

(SH240.47) *DEATHMASTER*: The *Deathmaster* was conducting security operations before it was ordered on this raid. It had to fight its way through Federation covering ships, and its escorts are involved in holding open its path of retreat.

(SH240.471) The *Deathmaster* lost three of its PFs and six of its fighters in breaking through to reach the station. The fighters each have one die roll of damage. For each unit roll one die and score the indicated number of points of internal damage.

(SH240.472) For each PF, roll one die to select a shield facing and then two dice to determine the number of damage points that are scored on that shield. If more damage than the strength of the randomly selected shield is rolled, ignore the excess and simply mark the shield as destroyed. The PFs have repaired other shield damage.

(SH240.473) The deck crews only had time to reload the fighter's drone rails before arriving in this scenario; they did not have time to perform repairs on the fighters or load the shuttles as scatter packs (they could be prepared as suicide shuttles). The PFs have all expended their normal damage control (this would have been in addition to the random points of internal damage, thus if a PF rolled only one point of internal damage it would still have one destroyed hull box), but EDR remains available as do shield repairs.

(SH240.474) Reduce the *Deathmaster's* #2 shield to eight boxes and resolve a volley of ten points of internal damage through that shield arc. The ship may then repair any two boxes and will begin the scenario with two CDR repairs remaining. The Player may choose to not repair any systems or repair only one system in order to preserve the flexibility to repair other systems.

(SH240.475) The *Deathmaster* only has 50 spaces of reload drones remaining, these will be proportional to what is loaded on the fighters and PFs at the start of the scenario.

(SH240.476) The fighters can be equipped with any pods normally available in a pod stockpile as given in (J11.13).

(SH240.477) The *Deathmaster* must disengage by acceleration in direction E or F by the end of Turn #10, or it will be destroyed by additional Federation reinforcements.

(SH240.5) VICTORY CONDITIONS: If the Klingons successfully recover the data file and disengage the *Deathmaster*, they win, otherwise they lose.

If the Federation destroys the *Deathmaster* they win; otherwise they lose.

(SH240.6) VARIATIONS: The scenario can be played again under different conditions by making one or more of the following changes:

(SH240.61) Replace the Klingon UD7 with a Romulan SUU.

(SH240.62) Assume that the Romulan agent managed to put a marker on the data file that the Klingons can detect. The UD7 must scan the base and gather 100 points of lab information to determine the data file's location. Once this information is gathered, the data file can be recovered by a single successful hit-and-run raid against it, but the boarding party must survive the raid (a result of success but boarding party destroyed means failure in this case). The Federation cannot detect the marker and therefore cannot guard against the hit-and-run raid.

(SH240.63) For a smaller battle, replace the UD7 with an FWP, and use only the Federation ADW and its escort. The Federation units begin on the map in the place of the starting

DW and the skiff. In this variation, the Klingons automatically recover the data file if the ADW and its escort are destroyed or forced to move more than ten hexes from the station while the Klingon FWP is within five hexes of the station.

(SH240.7) BALANCE: The scenario can be balanced between players of different skill levels by one or more of the following:

(SH240.71) Add a PF or one or two Z-YBs to the Klingon forces or delete a PF or one or two fighters.

(SH240.72) Replace the Federation FFA+ with a DWA.

(SH240.73) Decrease or increase the starting damage on the some of the Klingon units.

(SH240.8) TACTICS

FEDERATION: For you this is a game of pressure. You have to keep the Klingons under pressure so that they cannot get ten boarding parties on the station and recover one later. Collectively, your ships have enough power to beat the UD7, but you need to gather them while preventing the Klingons from placing their boarding parties on the station. Reinforcing the defending boarding parties is questionable, as the effort to get your own boarding parties over may delay your attacking the UD7, and they may not be able to kill all the Klingon units fast enough. Keeping the UD7 away from the station will make it harder for him to get enough boarding parties on the station (and keep them alive long enough) to find the file, much less recover the boarding party once success is achieved. Try to take advantage of the existing damage to the Klingon units, but do not expect the Klingons to turn down or weak shields to you.

KLINGON: You have enough transporters to move seven boarding parties in a single lift, and you start with 16. But surviving three rounds of combat aboard the station is going to be rough. Remember, it is going to be three rounds because the clock does not start until you have placed ten boarding parties on the station. Make sure to buy as many extra marines as you can. (Being able to defend the ship from Federation boarding parties could become an issue if you send too many to the station, and you need to send a lot.) Form militia to defend the ship, and beam some of them over when you have a lodgment, because you need to have a survivor to beam out later. Try to hit the DW and skiff hard and take them out of play immediately. It will take all you have to take out that NLF with its power curve, and you cannot afford to be taking your time. Expect to sacrifice the PFs and the fighters as well as the bulk of your marines. But if you get the data file, their sacrifice will have been worth it.

HISTORICAL OUTCOME: The Federation GIA agents, supported by some of the base's security personnel, soon tracked down the Romulan agent. In the ensuing gun battle, the Romulan succeeded in killing both of the GIA agents and two members of the security team, wounding four more, before being killed himself. Tragically, the GIA agents had not advised the crew of the skiff, or the members of the security team, the reason why the capture of this Romulan agent had been so vital. It was only when the *Deathmaster* was approaching the station that coded messages were sent to the Federation captains explaining the situation.

In the furious fight that followed, the *Taylor* was gutted and the *Pulaski* was heavily damaged. Most of the *Deathmaster's* marine company died fighting on the decks of the station in an ultimately futile effort to find the data file. The *Deathmaster* was forced to disengage to avoid destruction, hotly pursued by the *Bolivar* until she linked up with her damaged escorts.

(SH241.0) JUST CAUSE



(Y184)

by Steven Paul Petrick, Texas

The Vudar Enclave, as it sought to establish itself, had expanded into space that was part of the Hydran Kingdom. The parts of the Kingdom the Vudar expanded into were, at the time, under the control of the Klingon Empire. The Klingons, under heavy strain at that point in the General War, ceded the space to the Vudar in an effort to divert Hydran combat power against the Vudar (a ploy that worked all too well).

The principle focus of the Hydran Kingdom's combat operations from Y182 until the arrival of the ISC (and later the Andromedans) was the reclamation of all its pre-war holdings. (This did not stop them from launching "punitive expeditions" against the Klingons and the Lyrans when opportunity presented itself.) The operations against the Vudar included some major attacks, but consisted mostly of a series of limited duration raids to keep the Vudar from firmly securing their new frontier. The Vudar responded to such incursions as strongly as they could, realizing that to show weakness to the Hydran Kingdom would invite larger attacks sooner than they could afford, and worse (at least according to Klingon historians) prove to the Klingons that it would be possible to reabsorb the enclave.

In Y184, the Hydrans sent the *Just Cause* on a raid into Vudar space. As the *Cause* was trying to make its way back to Kingdom-held space, the *Firebolt* tracked it to an asteroid field it had ducked into to throw off pursuit. The *Cause* began accelerating, believing it had to destroy the *Firebolt* before help arrived. The *Firebolt* moved to block the *Cause's* escape.

(SH241.1) NUMBER OF PLAYERS: 2; the Hydran player and the Vudar player.

(SH241.2) INITIAL SET UP

TERRAIN: The entire map is an asteroid field (P3.11).

HYDRAN: DWP *Just Cause* in 4012, heading E, speed zero, WS-III. See (SH241.45) for PFs.

VUDAR: Light PF tender *Firebolt* in 1622 with three PFs docked, heading B, speed 6, WS-III.

(SH241.3) LENGTH OF SCENARIO: The scenario continues until all forces belonging to one side have been destroyed, captured, or have disengaged.

(SH241.4) SPECIAL RULES

(SH241.41) MAP: The map is fixed; it does not float. Any unit leaving the map has disengaged and cannot return. The Hydran units can only disengage from the 01xx map edge. The Vudar units can disengage from any map edge except the 01xx edge. Units which disengage in unauthorized areas are considered destroyed.

(SH241.42) SHUTTLES AND PFs: All shuttles and PFs have warp booster packs; all shuttles are advanced types.

(SH241.421) No ship in this scenario is qualified to carry a MRS shuttle, but in a variant of the scenario where that is possible, they may be purchased [up to the limits in (J8.5)] under (SH241.431).

(SH241.422) There are no fighters in this scenario. In a variant in which fighters are present, use the standard

deployment patterns (one EWF for each squadron of eight or more fighters) for EW fighters.

(SH241.423) The three PFs on the *Firebolt* are standard combat types, see (SH241.45) for the PFs on the *Just Cause*.

(SH241.43) COMMANDER'S OPTION ITEMS

(SH241.431) The *Firebolt* can purchase additional or special equipment as Commander's Option Items (e.g., T-bombs, extra marines, etc.) up to 20% of its Combat BPV.

The *Just Cause* can purchase additional or special equipment as Commander's Option Items (e.g., T-bombs, extra marines, etc.) up to 10% of its Combat BPV, **ROUNDED UP**.

See (S3.2) for details and exceptions.

(SH241.432) The races that are involved in this scenario do not use drones. In a variation where a drone-armed race is used, all drones are "fast," i.e., speed-32.

Each drone-armed ship can purchase special drones up to the historical racial percentages as part of the Commander's Option Items. Note that (S3.2) allows drone ships extra points for this purpose.

(SH241.433) Historically, the *Just Cause* carried a Prime Team that was part of its raiding mission. The *Firebolt* did not carry such a team. If the players do not wish to use the rules for Prime Teams, delete the Prime Team and add a Harbinger Interceptor to the *Just Cause*.

(SH241.44) REFITS: The PFs of both sides have all received the shield refit.

(SH241.45) JUST CAUSE: The Hydran DWP was returning from a special mission strike on a Vudar facility. Its PFs had been tailored for that surprise raid, and one of them was lost (one that had been carried in the internal repair bay) and much of the stores the ship had carried had been expended. The three PFs remaining to the *Just Cause* are a Harrier, a Valkyrie, and a ground assault variant. The Valkyrie had been used to ferry GAS shuttles to support the raid, and recovered two of them (held on the mech links). The *Just Cause* had a Stinger-F fighter, which was lost on the mission, but it has replaced the lost fighter with a GAS shuttle that survived the raid. (The Hydrans have three GAS shuttles.) All damage to the PFs and the shuttles on the raid was repaired (the shuttles were rotated through the shuttle bay while the ship was hiding from pursuit). The extra boarding parties the ground assault PF would normally carry had to be drawn from the DWPs own boarding parties or purchased with Commander's Option points. If the *Just Cause* does not expend any Commander's Option points for extra boarding parties, they are simply assumed to have been the casualties lost on the raid. This makes it possible for the *Just Cause* to spend its Commander's Option points for T-bombs or other things.

(SH241.46) DISENGAGEMENT: The Vudar DWP will not disengage unless it has been crippled. The Hydran DWP cannot disengage unless the Vudar DWP has been destroyed, captured, or has disengaged. If the Hydran DWP disengages by sublight evasion it is considered destroyed.

(SH241.5) VICTORY CONDITIONS: The Vudar win if the Hydran DWP is destroyed or captured. This is irrespective of the fate of the Vudar DWP as destruction of the Hydran raider will help discourage further raids. The Hydrans win if the Vudar DWP is destroyed, captured, or disengages and the *Just Cause* is not crippled to such a state that it is unable to repair itself under the Tactical Repair rules (G17.131), to include using EDR (D14.0), to an uncrippled condition. Note that the scenario can be extended to allow the completion of the allowed repairs, and that surviving Vudar PFs or other

units might further damage the ship even if the *Firebolt* has been lost.

(SH241.6) VARIATIONS: The scenario can be played again under different conditions by making one or more of the following changes:

(SH241.61) Replace the DWPs of the one or both sides with a DWP from another race or races.

(SH241.62) For a larger battle, assume the Hydrans sent two DWPs on the mission and the Vudar built a second DWP and both have arrived to combat the Hydrans. In this case place the second DWP in the same hex at start as the first DWP. Or allow one side to use two DWPs and the other side to use a PFT with appropriate adjustments (e.g., Valkyrie and ground assault PFs on a Hydran PFT, standard combat PFs on a Vudar PFT).

(SH241.63) Historically, the Vudar would not have known what PFs the *Just Cause* was operating. Place ten counters numbered #1 through #10 (ten drone counters would do) into a cup. Have the Vudar player create a list of Hydran PFs in any order he wishes but including no more than one Howler, two Hellions, two Harriers, two Valkyries, two ground assault PFs, and one Harbinger interceptor. Each valkyrie will have two GAS shuttles and each ground assault PF will only have its one normal defensive boarding party. The Hydran player then draws three counters, comparing the numbers to those on his list to determine what PFs the *Just Cause* has available. The counters and the list are then set aside for the Vudar player to examine and compare to what he encountered once the scenario has ended.

(SH241.7) BALANCE: The scenario can be balanced between players of different skill levels by one or more of the following:

(SH241.71) Allow the weaker player to replace one of his combat PFs (the Harrier in the case of the Hydran player) with a leader version.

(SH241.72) Allow one player to include a fourth PF in the internal bay of his DWP.

(SH241.73) Convert the admin shuttle on the *Just Cause* into a Stinger-F.

(SH241.8) TACTICS

VUDAR: While your ship is expendable, you can only expend it if you kill the Hydran ship. While your PFs are combat versions and most of his are support versions, the Hydrans all include phaser-Gs that can be deadly at close range. The Hydrans also have more boarding parties than you do and can crash land shuttles in your bay, so you should plan on buying a few extra boarding parties yourself. Avoid letting the Hydrans mass for an overrun.

HYDRAN: You have a lot of firepower in your phaser-Gs, but not a lot of long-range firepower. Fortunately, the asteroids are going to make it hard for the Vudar to use his long range advantage, but it still puts the onus on you to close the range, otherwise he will be able to wear you down while your phaser-Gs will have little effect.

HISTORICAL OUTCOME: The *Just Cause* succeeded in overrunning the *Firebolt* and disengaging from the *Firebolt's* PFs. The maneuver required the sacrifice of the *Just Cause's* PFs. The success was made possible by the Prime Team's successful capture of one of the Vudar PFs, which tipped the scales in favor of the *Just Cause* at a critical moment. The Prime Team later returned to Hydran Space on a captured Klingon freighter, bringing with them the survivors of two of the Hydran PFs and Vudar they had captured.

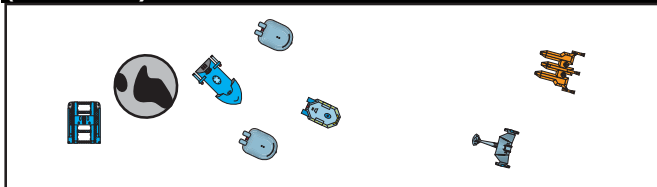
(SH242.0) GAMBLE

(Y184)

by Steven Paul Petrick, Texas

As part of the preparations for a major option, the Federation moved an FRX very close to the front lines. It was anticipated that an assault on the Klingon defenses in the sector would result in heavy damage to the X-squadron that was be the spearhead creating the penetration the rest of the fleet would exploit. The plan was for the X-squadron to create the breach, then fall back on the FRX for repairs, before taking up the role of reserve.

As part of the deception operation leading up to the attack, the X-squadron was to make several attacks elsewhere along the front, before shifting suddenly (over a few weeks) to the primary sector, appearing abruptly where the Klingons would not be expecting it.

To this end, the FRX was brought forward.

Unfortunately, things were not going as planned. The ships originally assigned to cover the FRX were called away to deal with a local Klingon attack and a subsequent raid on a convoy by Orions. Fleet command knew it was a gamble to leave the FRX where it was, but reasoned that the light forces available would be enough to screen it for a short while.

It is not known if the Orions were working with the Coalition, or if the Coalition was even aware that the FRX was located in the system. All that is known is that two fast war cruisers suddenly burst through the Federation front and drove straight to the FRX's location.

(SH242.1) NUMBER OF PLAYERS: 2; the Federation player and the Coalition player.

(SH242.2) INITIAL SET UP

TERRAIN: Class M planet in hex 2215.

FEDERATION: FRX *John Ericsson* with two hangar modules (12xF-18C) in hex 2214 in standard orbit (P8.0), initial heading C, WS-III.

Light Monitor *Redoubt #10* with hangar pallet (12xF-18B), FEV *Chuyo* (6xF-18), PTC *Paktar #7*, and CUT *Sentinel* set up anywhere within five hexes of the planet, initial heading at the Federation player's option, speed 10, WS-III. See (SH242.45).

COALITION: FD5 *Thunderaider* (2xG1) and CWF *Silver Streak* (2xBobcat) enter anywhere along the 01xx map edge, heading B or C, speed max, WS-III.

(SH242.3) LENGTH OF SCENARIO: The scenario continues until all forces belonging to one side have been destroyed, captured, have disengaged, or until the end of Turn #12.

(SH242.4) SPECIAL RULES

(SH242.41) MAP: The map is fixed; it does not float. Any unit leaving the map has disengaged and cannot return. The Federation units can disengage from any map edge except the 01xx map edge. The Coalition units can only disengage from 01xx map edge. Units which disengage in unauthorized areas are considered destroyed.

(SH242.42) SHUTTLES AND PFs: All shuttles and PFs have warp booster packs. All shuttles are advanced types.

(SH242.421) No ship in this scenario is qualified to carry an MRS shuttle, but in a variant of the scenario where

that is possible, they may be purchased [up to the limits in (J8.5)] under (SH242.431).

(SH242.422) If using EW fighters, one of the F-18Cs on the FRX and one of the F-18Bs on the light monitor are EW versions. If not using EW fighters, they are standard fighters of their respective squadrons.

(SH242.423) The two G1s carried by the FD5 and the two Bobcats carried by the CWF are standard combat types.

(SH242.43) COMMANDER'S OPTION ITEMS

(SH242.431) Each ship can purchase additional or special equipment as Commander's Option Items (e.g., T-bombs, extra marines, etc.) up to 20% of its Combat BPV. See (S3.2) for details and exceptions.

(SH242.432) All drones are "fast," i.e., speed-32.

Each drone-armed ship can purchase special drones up to the historical racial percentages as part of the Commander's Option Items. Note that (S3.2) allows drone ships extra points for this purpose.

(SH242.433) Prime Teams (G32.0) are not available in this scenario.

(SH242.44) REFITS: The FD5 has the mech link and K refits. The CWF has the plus, phaser, power pack, UIM, and mech link refits. All units have the Y175 refit if one is available. Coalition PFs all have the shield refit.

(SH242.45) WEAPONS: The FEV and PTC are both armed with type-G drone racks. The drone racks on the CUT are type-G.

(SH242.46) DISENGAGEMENT: The Coalition ships must disengage if they have more than 25 points of internal damage at the end of any given turn after repairs. This is judged individually for each ship, e.g., if the FD5 has 26 points of internal damage at the end of Turn #4 it must disengage but the CWF can continue to fight. The PFs are expendable for all purposes.

(SH242.5) VICTORY CONDITIONS: If the FRX is destroyed, and both Coalition ships successfully disengage, the Coalition wins. If the FRX is not destroyed, the Coalition loses. Any other result is a draw, e.g., if the FRX is destroyed but one of the Coalition ships is also destroyed, the scenario is a draw.

(SH242.6) VARIATIONS: The scenario can be played again under different conditions by making one or more of the following changes:

(SH242.61) Move the action to the Hydran front by replacing all the fighters with Stinger-2s and the drone racks on the FEV, PTC, and CUT with phaser-2s as appropriate.

(SH242.62) Replace the Coalition ships with an Andromedan Intruder carrying three Cobras. The Cobras are expendable, but the Intruder must withdraw if it takes more than 40 points of internal damage, and is destroyed if it does not exit the map by the end of Turn #12.

(SH242.63) For a larger battle, replace the light monitor with a full size monitor carrying a space control pallet and use a Klingon FD7 and Lyran CF.

(SH242.7) BALANCE: The scenario can be balanced between players of different skill levels by one or more of the following:

(SH242.71) Change the F-18Bs to F-18B+s.

(SH242.72) Replace the FEV with a PV carrying 12 F-18s.

(SH242.73) Delete one or more refits from the Coalition ships.

(SH242.8) TACTICS

FEDERATION: The ships and fighters are expendable. The FRX must be saved. That is the be all and end all of what you do here. Keep a screen of drones between the FRX and the Coalition ships as long as you can, and concentrate your

fire on one of them at a time. Have the FRX break orbit on impulse power as you do not want the coalition trying to shove it into the planet.

COALITION: The FRX is the thing. But it is big, and has a lot of power. Keep in mind that killing the other Federation ships will reduce both their drone throw weight, and their ability to control drones. So concentrate on that as a first step. The fewer control platforms they have, the fewer drones they can have in flight at one time, and the more firepower you will have to eliminate the fighters so that you can attack the FRX.

HISTORICAL OUTCOME: In a bloody melee the defending Federation ships were annihilated and the FRX was heavily damaged. The sacrifice of the escorts enabled it to survive, but it was not able to perform its slated mission, having to be withdrawn for major repairs.

The result was that Admiral Radey's carrier group would be unsupported by the X-squadron in the coming operation.

Both Coalition ships sustained moderate damage and successfully escaped back to Coalition held space.

The Federation gamble had been a failure.

(SH243.0) BUSTING THE HAND-OFF



(Y169)

by Steven Paul Petrick, Texas

One of the primary uses of theater transports is the reconfiguring of tugs for different missions by bringing forward the pods needed for the new assignment. This saves time by keeping the fleet tug closer to the combat area. In this way, the amount of time it spends "deadheading" (not carrying a pod at all, or carrying empty cargo pods) is limited.

Sometimes the tempo of operations necessitates that the theater transport deliver the new pod as close to the combat area as possible. This is always supposed to be done in a 'secure' area.

Occasionally, however, the secure area is not as secure as was thought, and in these circumstances, things can get more than a little exciting for all involved.

Once such case occurred in Y169, as the Hydrans were in the process of changing one of their tugs to a combat mission.

(SH243.1) NUMBER OF PLAYERS: 2; the Hydran player and the Klingon player.

(SH243.2) INITIAL SET UP

HYDRAN: Tug *Capacious* (3xStinger-1) with cargo pallet in hex 2215, heading A, speed one, WS-I.

FFT *Swift Sender* with a combat pallet in hex 2215, heading A, speed one, WS-I. See (SH243.45).

KLINGON: F5C *Reaver* and F5 *Harasser* enter anywhere along 01xx map edge, heading A or B, speed max, WS-III.

(SH243.3) LENGTH OF SCENARIO: The scenario continues until all forces belonging to one side have been destroyed, captured, or have disengaged.

(SH243.4) SPECIAL RULES

(SH243.41) MAP: Use a floating map. The Hydran units can disengage in any direction but B or C. The Klingon units can

only disengage in directions B or C. Units which disengage in unauthorized directions are considered destroyed.

(SH243.42) SHUTTLES AND PFs: No shuttles or PFs have warp booster packs. Shuttles are not advanced types.

(SH243.421) MRS shuttles may be purchased [up to the limits in (J8.5)] under (SH243.431).

(SH243.422) EW fighters were not available at the time of this action and no ship in the scenario is qualified to carry one in any case. In a variation where EW fighters are allowed, use the standard deployment patterns (one EWF for each squadron of eight or more fighters) for EW fighters.

(SH243.423) There are no PFs at the time of this scenario. PFs might be added in a variation.

(SH243.43) COMMANDER'S OPTION ITEMS

(SH243.431) Each ship can purchase additional or special equipment as Commander's Option Items (e.g., T-bombs, extra marines, etc.) up to 20% of its Combat BPV. See (S3.2) for details and exceptions.

(SH243.432) All drones are "medium," i.e., speed-20.

Each drone-armed ship can purchase special drones up to the historical racial percentages as part of the Commander's Option Items. Note that (S3.2) allows drone ships extra points for this purpose.

(SH243.433) Prime Teams (G32.0) are not available in this scenario.

(SH243.44) REFITS: Are as listed in (SH243.2). Note that the Hydran tug does not have the plus refit.

(SH243.45) PALLET: The FFT is carrying a combat pallet. This pallet is inactive.

(SH243.451) The combat pallet can be activated by attaching it to the tug and having the tug apply 10 continuous damage repair points to the pallet over three consecutive turns. These "repairs" represent completing the power connections between the tug and the pallet. These "repairs" cannot be done at the same time as the tug performs any (D9.7) or (D14.0) repairs on itself, and are aborted and must be started over if the tug repairs itself. Note that (D9.2) repairs do not interrupt activating the pallet.

(SH243.452) The pallet's own power-generating systems cannot be activated during the scenario (it would take far more time than the length of the scenario to activate the auxiliary reactors and any impulse engines), but batteries operate normally. All other systems operate normally, starting the turn after the tenth CDR point is applied.

(SH243.453) The pallet's crew is being carried as passengers on the theater transport. A minimum of four crew units needed to operate the pallet must be transferred to the pallet, once it is activated, in order for any of its systems to be used. Only the pallet's own crew can operate it, so they must be transferred to it in order to use any of its systems.

(SH243.454) The pallet cannot operate fighters during the scenario. (Its own fighters would take too long to break out of transport storage.)

(SH243.5) VICTORY CONDITIONS: The Klingon player wins if the tug is destroyed, for this purpose the tug is considered destroyed if it disengages by sublight evasion. The Klingon player loses if the tug disengages by distance or acceleration.

The Hydran player wins if the Klingons are driven off and the combat pallet is successfully transferred.

Any other outcome is a draw.

(SH243.6) VARIATIONS: The scenario can be played again under different conditions by making one or more of the following changes:

(SH243.61) Set the battle in an asteroid field.

(SH243.62) Replace the Klingon player's ship with a squadron of class-III fighters with warp booster packs. (This would assume a much later date for the scenario.)

(SH243.63) Replace the Hydrans with a tug and theater transport of another race. The tug used should be a transport tug. The tug will have one cargo pod and the theater transport will be carrying the appropriate battle pod. In the case of battle pods that include drones or ADD racks, these systems will be empty when the pod is activated and will have to be loaded in order to be used. They cannot be loaded until the pod is activated as per (SH243.45). The attacking force should be limited to two ships of a combined BPV of no more than 180 points not counting Commander's Options.

(SH243.7) **BALANCE:** The scenario can be balanced between players of different skill levels by one or more of the following:

(SH243.71) Replace the F5B with an E4B or the F5C with an F5B.

(SH243.72) Add a Gendarme to the Hydran force.

(SH243.73) Reduce the Commander's Option points available to one side or delete the B refit from the F5B or add the plus refit to the tug.

(SH243.8) TACTICS

KLINGON: While it may seem easier to kill the theater transport and destroy the pallet, the tug is the thing. If the tug goes down, it has to be replaced, and all the missions it is supposed to be doing are going to be unhinged. So even though it is harder to kill than the pallet or the theater transport (especially if it holds on to that cargo pallet), you need to pound it hard. The theater transport will likely stick around to cover the tug as best it can, and you can pick it up at your leisure. However, it is no big deal if it escapes.

HYDRAN: Why couldn't these guys show up *after* you got the combat pallet? You are going to have to optimize your defenses. Staying slow will leave you vulnerable, but it is the only chance you have to transfer the pallet and gain its combat power. It might be best to just run.

(SH244.0) CONVOY TERROR

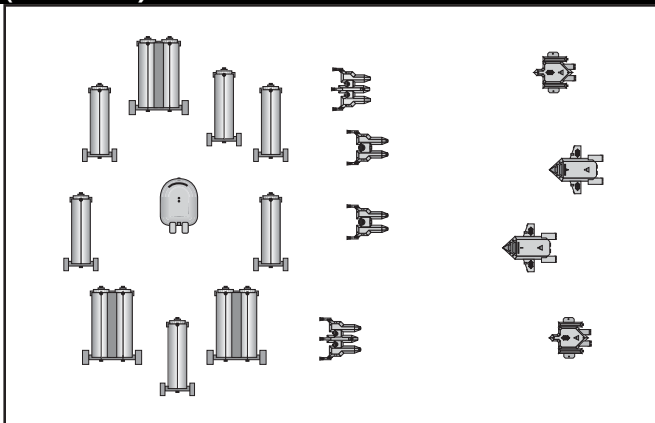

(Y179)

by Steven Paul Petrick, Texas

During the General War convoys became the normal way of doing business anywhere near a combat zone. The problem was providing them with enough escorts to protect them while not denuding the front lines of the forces needed to keep the enemy at bay. If all one had to worry about was the enemy beyond the fighting forces, the convoys would not have needed much of an escort.

In Y179, the Lyrans sent a convoy across Klingon space to the battle station (which had replaced an earlier one) they had established to support operations against the Federation.

The new battle station was further behind the lines, making it less susceptible to Federation or Kziniti interference. Unfortunately, the Orions could appear anywhere, even deep within an empire. And, increasingly, there were also the Andromedans.

In this case, it was later learned that the Federation had discovered the projected arrival time of the convoy, and while they had no force that could reach it, they did have credits to spend. The Daven Cartel was not above playing both sides, and knew that accepting such a contract could have a negative impact on the Cartel's relations with both the Klingon and Lyran Empires. A little judicious subcontracting, however, could avoid leaving a trail directly to the Cartel, and plausible deniability would be enough to keep the Lyrans and Klingons from taking combat forces away from the front lines to concentrate on damaging the Cartel's other operations.

As the convoy neared its destination, the Orions struck.

(SH244.1) **NUMBER OF PLAYERS:** 2; the Lyran player and the Orion player.

(SH244.2) INITIAL SET UP

LYRAN: MP *Red Hunter*, DWP *Huntmaster* (3xBobcat), POLs *Wild Hunter* and *Night Hunter*, set up in any hexes within three hexes of the convoy.

Convoy: 1xF-AL (disruptor) *Rojas' Pride*, 2xF-AS (phaser) *Fierce Bearer* & *Shield Carrier*, 2xF-L *Famine Breaker* & *Zarkoff #12*, 4xF-S *Raask*, *Rzakh's Flame*, *Solemn Charge*, & *Peladine #5*, 1xFT *Perrzear's Cub*. Place one ship of the convoy in hex 2215, then place six ships, each of them two hexes away in each direction (e.g. 2213, 2217, 2414, etc.). The remaining two ships can be placed anywhere within four hexes of 2215, but at least four hexes from each other. All ships of the convoy are heading B, speed 8, WS-I. See (SH244.45) and (SH244.46).

ORION: BR *Gimmie!*, MR *Heavy Axe*, DWs *Joker* and *Wasp*, enter from any map edge, heading at player's option, speed max, WS-III.

(SH244.3) **LENGTH OF SCENARIO:** The scenario continues until all forces belonging to one side have been destroyed, captured, have disengaged, or until the end of Turn #12.

(SH244.4) SPECIAL RULES

(SH244.41) **MAP:** Use a floating map. Lyran units can disengage in directions C, D, or E. Orion units can disengage in any direction except F, B, or A. Units which disengage in unauthorized directions are considered destroyed.

(SH244.42) **SHUTTLES AND PFs:** No shuttles have warp booster packs. All PFs have warp booster packs.

(SH244.421) No ship in this scenario is qualified to carry an MRS shuttle, but in a variant of the scenario where that is possible, they may be purchased [up to the limits in (J8.5)] under (SH244.431).

(SH244.422) There are no fighters in this scenario. In a variant in which fighters are present, use the standard deployment patterns (one EWF for each squadron of eight or more fighters).

(SH244.423) The three Bobcats carried by the *Huntmaster* are standard Bobcats.

(SH244.43) COMMANDER'S OPTION ITEMS

(SH244.431) Each ship can purchase additional or special equipment as Commander's Option Items (e.g.,

T-bombs, extra marines, etc.) up to 20% of its Combat BPV. See (S3.2) for details and exceptions.

(SH244.432) All drones are “medium,” i.e., speed–20. “Fast,” i.e., speed–32, are available for purchase as special drones.

Each drone-armed ship can purchase special drones up to the historical racial percentages as part of the Commander’s Option Items. Note that (S3.2) allows drone ships extra points for this purpose.

(SH244.433) Prime Teams (G32.0) are not available in this scenario.

(SH244.44) REFITS: No refits have been applied to any of the ships involved in this action except that any Orion ship with more than three drone racks has the OAKDISC refit.

(SH244.45) CONVOY: The merchantmen (freighters, armed freighters, free trader) of the convoy can never move in such a way as to be more than four hexes from the ship which starts in hex 2215. Should that ship be destroyed, the Lyran player may designate any other merchant ship of his choice as the new convoy-guide ship. Any Merchant ship that does not meet this requirement as a result of voluntary movement is considered destroyed. Merchant ships that are tracted by Orion ships are excused from this requirement.

(SH244.46) SKIDS AND DUCKTAILS: The Lyran player has the following skids and ducktails that he may assign to the freighters as he sees fit. No large freighter may have more than, or less than, two skids. No small freighter may have more than one skid. No freighter may have more than one ducktail and it must be appropriate to the size of the freighter.

SKIDS: 2xPSS, 1xCCS, 1xLASH, 2xGS, 2xSDS-2, and 2xSDS-3.

DUCKTAILS: 1xL-DT, 1xL-PT, 2xS-DT, 1xS-PT.

(SH244.47) ORION OPTION MOUNTS: Historically, the BR had 3xDisruptors and 2xDrone-B, the MR had 2xdisruptors and 2xDrone-B, and the DWs both had 1xDisruptor and 2xDrone-B.

(SH244.48) ORION WITHDRAWAL: The Orions have been paid to be here, and are not fighting for “Emperor and Empire” (or Cartel Lord and Cartel), and their ships are their source of income. If an Orion ship is crippled, or damaged to the point where one more point of internal damage would cause it to be crippled, it must immediately move to disengage. It cannot fire, or guide seeking weapons, at any ship of the convoy while moving to disengage.

(SH244.5) VICTORY CONDITIONS: Victory is based on the number of cargo boxes that survive in the convoy. Cargo boxes on the Lyran escorts (MP, POLs) do not count for this purpose. Destroyed cargo boxes that are repaired do not count for this purpose.

	LYRAN	ORION
300+	Astounding Victory	Devastating Defeat
275-299	Decisive Victory	Crushing Defeat
250-274	Substantive Victory	Brutal Defeat
225-249	Tactical Victory	Tactical Defeat
200-224	Marginal Victory	Marginal Defeat
175-199	Draw	Draw
150-174	Marginal Defeat	Marginal Victory
125-149	Tactical Defeat	Tactical Victory
100-124	Brutal Defeat	Substantive Victory
75-99	Crushing Defeat	Decisive Victory
Less than 75	Devastating Defeat	Astounding Victory

(SH244.6) VARIATIONS: The scenario can be played again under different conditions by making one or more of the following changes:

(SH244.61) Replace the Lyrans with a Kzinti Convoy by replacing the MP and both Pols with Police Corvettes.

(SH244.62) Replace the Orions with an Andromedan Python and a Conquistador carrying a Cobra.

(SH244.63) For a smaller battle, delete the Orion BR and MR and all the Lyran escorts. Use only the two DWs against the Convoy, but increase the number of turns to 20.

(SH244.7) BALANCE: The scenario can be balanced between players of different skill levels by one or more of the following:

(SH244.71) Change one or both of the POLs to MPs.

(SH244.72) Add two more SDS-2 skids to the convoy, or replace the two general skids with SDS-2 skids, or upgrade the two SDS-3 skids to SDS-2 skids.

(SH244.73) Delete or add a DW to the Orion force, or add an LR.

(SH244.8) TACTICS

CONVOY: You do not have much in the way of long-range firepower, so keep together and mass your fires on one ship at a time. The BR and MR are going to be tough, but remember you win on surviving cargo, so if you can make the DWs go away, that will reduce the incoming fire and make it a little harder on the Orions to rack up destroyed cargo boxes. Remember that all of your escorts are expendable, but try to avoid burning them all at once. You need to pace this out and make them last as long as they can.

ORION: Ignore the escorts as much as you can, but kill them if you get the chance to do it with minimal investment. Destroying the whole convoy is not a likely outcome. While it will not auto-kill them, tractoring individual freighters and dragging them off to where your drones can overwhelm their phaser defenses and destroy them is an option. The problem is that you have to go to close range of hornet’s nest of light phasers to do it.

HISTORICAL OUTCOME: Both POLs and the MP were destroyed. The DWP was heavily damaged and all three Bobcats were lost (two of the escape pods were recovered). The armed freighters were all lost imposing themselves between the other ships of the convoy, as was the Free Trader. The other freighters all sustained some damage, mostly from being overwhelmed by drones. The Orion MR and both the DWs were driven off, and only this saved the convoy from complete destruction.

The Lyran Fleet Command noted the value of the DWP’s Bobcats, and its special sensor, in the defense of the convoy. (The jamming of the BR on its attack runs was a significant contributor to the defense, and the Bobcat’s dogged pursuit of the MR caused the damage that forced it to disengage.) This led them to try to assign DWPs to every critical convoy, but there were never enough of them, and they had too many other jobs to do. The Orion deployment of Buccaneers degraded their use in the convoy role in any case.

ANNEX #3 MASTER SHIP CHART

See Page #57.

ANNEX #3A: MOVEMENT COST AND TURN MODES FOR TUGS AND LTTs

TUG CLASS	0 PODS	1 POD	2 PODS	3 PODS
Fed FFT	0.33 B	0.67 D	1.0D	N/A
Klingon E4T	0.33 A	0.67 D	1.0D	N/A
Klingon F5T	0.50 A	0.75 D	1.0D	N/A
Romulan SHH	0.33 A	0.67 D	1.0D	N/A
Kzinti FFT	0.33 A	0.67 D	1.0D	N/A
Kzinti DWT	0.50 B	0.75 D	1.0D	N/A
Gorn DDT	0.50 C	0.75 D	1.0D	N/A
Hydran FFT	0.33 A	0.67 D	1.0D	N/A
Lyrans DWT	0.50 A	0.75 D	1.0D	N/A
Lyrans FFT	0.33 A	0.67 D	1.0D	N/A
Lyrans NTG	1.0C	1.0C	1.5D	2.0E
LDR MPT	0.5A	0.75D	1.0D	N/A

ANNEX #3B MASTER PF CHART

A workboat entry was included in the Master Ship Chart.

ANNEX #7: DATA ON SHIPS

ANNEX #7B: SHIPS ABLE TO LAND ON PLANETS

AERODYNAMIC: Romulan HSE, Orion DWP.
 ENGINE: All workboats, FEV, PTC, FXE, Orion OPT and DWP.
 GRAVITY: Tholian DDS, DDV, Orion DWP.

ANNEX #7F NIMBLE UNITS

The following units are considered to be nimble for the purposes of (C11.1):
 All workboats; Federation POV, FXE; Romulan SHH†; Tholian DDS†; Orion DWP.
 † These units are only nimble if they are not carrying a pod (Romulan SHH) or pack (Tholian DDS).

WORKBOAT MECHANICAL LINKAGES

Workboats used a mech link similar to, but much less capable than, the mech link for a normal PF. These mech links can dock a PF, but cannot rearm it, replace its warp packs, or purge the ion build up in a warp pack. The only weapons that could be repaired are phaser-3s, and any repairs are part of the freighters own repair capacity.



OTHER COUNTERS

The countersheet for this product includes counters for several ships found in *Captain's Log #35*. See that product for the SSDs. The counters include:
 Small Fleet Oiler (SAO), Fast Naval Transport (FNT), Civilian Asteroid Mining Base Ship (HAM), Small Manufacturing Freighter (SAL), Small Prison Transport (SAJ), Penal Colony Control Station (PCS).

ANNEX #7G: CARRIER INFORMATION

Race	CV	Ftrs	Admin	Bays	Store	DC
General	Ftr Skid	0(2)	0	1	0	0
	LAH	12+6H	6	2	R1.13	24
	SAH	6H	3	1	R1.13	12
	FEV	6	2	2	25	6
Fed	CAV	6H	4	1	200	12
	DCS	12+6H	4	2 (+1M)	300	24
	DCSscr	12	0	1	100	12
	NHA	6H	2	1(+1M)	200	12
	P-HVL	6H	2	1(+1M)	rule	12
	POV	6	4	1	50	6
	ADW	3H	3	1(+1M)	50	6
Klingon	UD7	12	4	2	300	12
	M-11	6	0	1	60	6
Rom	SUU	12	4	2	150¥	12
	FAB	28	2	3	150¥	28
	FAK	12	2	1	100¥	12
Kzinti	DCS	12	2	1	300	12
Gorn	DCS	12	2	4	150¥	12
Tholian	DDV	8	1	1	0	8
Hydran	LHE	12	4	3	0	12
	PGR	2	8	4	0	2
Lyrans	NCV	12	2	4	200	12
WYN	DCS	12	2	1	250	12
ISC	DCS	12	4	1	200¥	12
Selt	DCS	12	4	1	200	12
Vudar	DCS	12	4	1	200†	12

This chart shows the numbers of fighters (Ftrs), administrative shuttles (Admin), shuttle bays (Bays), and deck crews (DC) that each of the listed ships has.
 † This assumes that drone-using fighters are present. If fighters that use plasma-D are present, drone storage represents plasma-Ds.
 ¥ These are type-D plasma torpedoes, not drones. The H in the Ftrs column indicates Heavy Fighters. +M indicates mech links for heavy fighters, all one bay. MRS shuttles are not shown or included. Tholian DDVs have one internal and eight external bays.

ANNEX #10 TACTICAL INTELLIGENCE HULL TYPE CLASSIFICATIONS

GENERAL SHIPS

APT CUT§.
 Bases when in space, see note #4.
 Ducktail Presence of a ducktail on a freighter is detected at level D, type of ducktail is detected at level F.
 FDX Federation FEX.
 FRD FRX, CDK§.
 Free Trader FEV, PTC§; Orion OPT.
 Ground Bases All small ground bases are of one type. Medium bases are §. Specific type of determined only by observation of systems or actions.
 Huge Auxiliary FTH§; Tholian HWT§.
 Large Auxiliary LAH, LAS§; Tholian LWT§.
 Light Monitor Light Monitor (presence of pallets detected at level D§).
 Skid Presence of a skid, or skids, on a freighter hull is detected at level D, the type of skid, or skids, is detected at level F.

Small Auxiliary ‡ ...SAH, SAS§
 Small Freighter ...FSF§.

UNITED FEDERATION OF PLANETS SHIPS

CA CV‡.
 CV‡ CAV, DCS§.
 DW ADW§, DWR.
 FEX FEX.
 GCA GSR§.
 NCA NCV‡.
 NCL NLF.
 NCV NHA§.
 POL POV.

KLINGON EMPIRE SHIPS

D5 FD5, KDS.
 D5W ADW.
 D7 DV.
 DV UD7§.
 E4 E4S, E4T‡ with pod.
 F5 F5T‡ with pod.
 F5W FWP§.

ROMULAN STAR EMPIRE SHIPS

FH SUU§, FAK, FAB, FHM.
 WE HSE§.
 SEH SHH‡ with pod.
 SPH FSP.
 KDS Klingon D5. These ships may be distinguished indirectly by identifying their weapons.

KZINTI HEGEMONY SHIPS

C CVH‡.
 CM CMF.
 CVH‡ DCS§.
 DW DWP§, DWT‡ with pod.
 FF FFT‡ with pod.

CONFEDERATION OF THE GORN SHIPS

CA DCS§.
 BDD PTD§.
 DD DDT‡ with pod.
 HDD HDF.
 LCL LCS.

THOLIAN HOLDFAST SHIPS

DD DDV§, DDS.
 HWT General Huge Auxiliary.
 LWT General Large Auxiliary.

ORION MERCHANTS ASSOCIATION SHIPS

DW DWP§.
 FT Prime Traitor; Civilian Free Trader.

HYDRAN KINGDOM SHIPS

CA CC‡.
 CC‡ LHE§.
 DM Hun.
 DW DWP§.
 FF FFT‡ with pallet.
 PG PGR.

ANDROMEDAN TOURISTS SHIPS

Battle Station BATS, BAC§.
 COQ CCR§.
 INT IMB§.
 SS-Medium CBR§.

LYRAN STAR EMPIRE SHIPS

CW CWF.
 DW‡ DWP§, DWT‡ with pod.
 FF FFT‡ with pod.
 NCA NCV§, NSC, NTG.
 MP‡ MPT‡ with pod, MPP§.

WYN CLUSTER SHIPS

CA DCS§.
 CW CWF.

INTERSTELLAR CONCORDIUM SHIPS

CA DCS§.
 CL CLF, CBR.
 DD DDP§.
 NDD NDD.
 NFF NFF.

LYRAN DEMOCRATIC REPUBLIC SHIPS

The LDR ships are included in the Lyran section.

SELTORIAN TRIBUNAL SHIPS

CA DCS§.
 CL CLS.
 NCA NSC.
 DD DDP§.

VUDAR ENCLAVE SHIPS

CA DCS§.
 DW DWP§.

TACTICAL INTELLIGENCE NOTES

1. Each classification includes all refits and any unlisted variants.
2. PFs within each race/type are the same hull type. (Note that some races have two types, e.g., Romulan StarHawk and Centurion. Also, WYN-foreign PFs are reported as a PF of the original race-type.) Interceptors of that race are distinguishable from PFs as §. (Romulan Decurion looks like Centurion§.)
3. Pods (each race) are a single hull type; "heavy" pods are distinguishable as §. This includes base augmentation modules.
4. Each type of base is a separate hull type, with the exception that SAMS and ComPlats are of a ‡ group.
5. Each X-ship will be reported in the same category as the non-X ship on which it is based; further identification happens only when their increased or improved systems are detected; see (XD17.196). (Exception: Federation DDX and SCX form a new category as they are the only "new" X-ship hull type.)

‡ Ships of this ‡ group can only be distinguished from each other by their actions (e.g., how many fighters they launch), or by boarding them.

‡ Not a class, but a grouping of similar hull types distinguishable from the larger category at Level D.

§ Major outward differences distinguishable at Level D.

Class	Ship Type	G9.0 Crew Units	D7.0 Brdg Prts	S2.1 BPV	C6.5 Break Down	C2.12 Move Cost	J1.42 Spare Shuttles	R0.6 Size Class	C3.3 Turn Mode	Rule Number	Year In Service	C13.3 Dock Points	D5.2 Explos Strength	F&E Cmnd Rating	War Ship Status	Notes
R1.0 GENERAL UNITS																
HEAVY AUXILIARY	FTH	89	130	290/90	3-6	1.00	—	3	E	74	175	9	19	4	LPW	ML, T
LARGE AUXILIARY	LAH	40	4	130/90	3-6	0.67	2+2+1H	3	D	75	N-HF	6	13	6	RPA	ML, D%, V, VH
FREE TRADER	LAS	20	6	100/25	3-6	0.67	—	3	D	77	165	6	12	0	LPW	ML, ◆
	FEV	9	4	30	4-6	0.50	0+1	4	C	84	167	3	6	2	RPW	V
	PTC	10	4	53	4-6	0.50	—	4	C	85	135	3	9	3	RPW	
SMALL AUXILIARY	SAH	20	2	80/55	3-6	0.33	0+1H	4	C	76	N-HF	3	6	3	RPA	ML, D%, VH
	SAS	8	4	50/20	3-6	0.33	—	4	C	78	165	3	6	0	LPW	ML, ◆
	F-SF	4	2	45/16	1-6	0.33	—	4	C	82	200	3	5	0	LPW	ML
LIGHT MONITOR	LMN	24	10	50/100	3-6	0.33	1	4	C	83	130	4	14	3	LPW	ML
ARMED TRANSPORT	CUT	7	3	30	3-6	0.20	—	4	C	86	130	1	7	3	RPW	
SKIFF	LB	1+5	11	10	4-6	0.20	—	5	B	87	140	1	1	3	RPW	Troops
FAST PATROL SHIP	WB	1	1	20	6	0.20	—	5	AA	R1.PF7	183	1	8	0	RPW	De-militarized
BASE	CCS	45	10	65/43	—	■	1	4	—	79	125	6+2+2	9	0	RPW	◆
	CDK	10	2	600/10	—	■	—	1	—	80	20	—	9	0	Special	◆
	CPOB	28	6	30/7	—	■	4+1H*	5	—	72	140	6	0	0	RPW	Ground Base
	FRX	100	12	300/75	—	△	2	2	—	81	182	36	16	0	RPW	X
	CSOB	18	2	17/4	—	■	2	5	—	73	140	4	0	0	RPW	Ground Base

Class	Ship Type	G9.0 Crew Units	D7.0 Brdg Prts	S2.1 BPV	C6.5 Break Down	C2.12 Move Cost	J1.42 Spare Shuttles	R0.6 Size Class	C3.3 Turn Mode	Rule Number	Year In Service	C13.3 Dock Points	D5.2 Explos Strength	F&E Cmd Rating	War Ship Status	Notes
SKID	PSS	3	2	+10	—	■	—	5°	—	68C	140	1	+1	0	RPW	Skid
	CCS	3	2	+8	—	■	—	5°	—	68D	140	1	+1	+3	RPW	Skid
	LSS	3	0	+8/4	—	■	—	5°	—	68E	140	1	+1	0	RPW	Skid
	CGOS	0	0	+8/4	—	■	—	5°	—	68F	140	1	0	0	RPW	Skid
	PWRS	3	0	+10/7	—	■	—	5°	—	68G	140	1	+2	0	RPW	Skid
	SHTS	2	0	+8	—	■	—	5°	—	68H	140	1	0	0	RPW	Skid
	SARS	3	0	+15/5	—	■	—	5°	—	68I	140	1	0	0	RPW	Skid
	SALS	5	0	+8/4	—	■	—	5°	—	68J	140	1	0	0	RPW	Skid
	MEDS	3	0	+12/4	—	■	—	5°	—	68K	140	1	0	0	RPW	Skid
	REPS	5	0	+12/4	—	■	—	5°	—	68L	140	1	0	0	RPW	Skid
	CONS	3	0	+7/5	—	■	—	5°	—	68M	140	1	+1	0	RPW	Skid
	TUGS	3	0	+10/5	—	■	—	5°	—	68N	140	1	+1	0	RPW	Skid
	FACS	5	0	+10/4	—	■	—	5°	—	68O	140	1	0	0	RPW	Skid
	MINS	4	0	+8/3	—	■	—	5°	—	68P	140	1	0	0	RPW	Skid
	PRDS	5	0	+12/4	—	■	—	5°	—	68Q	140	1	0	0	RPW	Skid
	SCIS	3	0	+12/4	—	■	—	5°	—	68R	140	1	0	0	RPW	Skid
	ACOS	2+10	0	+5	—	■	—	5°	—	68S	140	1	0	0	RPW	Skid
	SDS1	4	2	+10	—	■	—	5°	—	68T	140	1	+2	0	RPW	Skid
	SDS2	4	2	+9	—	■	—	5°	—	68U	140	1	+1	0	RPW	Skid
	SDS3	4	2	+7	—	■	—	5°	—	68V	140	1	+1	0	RPW	Skid
	FTRS	3	0	+8	—	■	—	5°	—	68W	140	1	0	0	RPW	Skid
	WBS	3	0	+13/4	—	■	—	5°	—	68X	140	1	0	0	RPW	Skid
	PFS	3	0	+15/4	—	■	—	5°	—	68Y	140	1	0	0	RPW	Skid

Class	Ship Type	G9.0 Crew Units	D7.0 Brdg Prts	S2.1 BPV	C6.5 Break Down	C2.12 Move Cost	J1.42 Spare Shuttles	R0.6 Size Class	C3.3 Turn Mode	Rule Number	Year In Service	C13.3 Dock Points	D5.2 Explos Strength	F&E Cmnd Rating	War Ship Status	Notes
DUCKTAIL	L-PT	2	0	+10/4	—	■	—	5°	—	69B2	140	1	+1	0	RPW	Ducktail
	L-WT	3	0	+10/4	—	■	—	5°	—	69B3	140	1	0	0	RPW	Ducktail
	S-PT	2	0	+8/3	—	■	—	5°	—	69A2	140	1	+1	0	RPW	Ducktail
	S-WT	3	0	+8/3	—	■	—	5°	—	69A3	140	1	0	0	RPW	Ducktail
R2.0 UNITED FEDERATION OF PLANETS																
HEAVY CRUISER	CAV	46	10	156	5-6	1.00	2+2H	3	D	132	177	8	17	9	RPW	VH, D%
	DCS	46	10	157/110	5-6	1.00	1+2+1H	3	D	133	178	8	15	9	LPW	V, H, ◆
NEW HEAVY CRUISER	NHA	42	10	150/130	5-6	1.00	2+1H	3	D	134	177	8	18	8	RPL	VH, ◆
OLD HEAVY CRUISER	GSR	38	10	123/83	5-6	1.00	2	3	D	138	140	6	12	8	NFP	◆
NEW LIGHT CRUISER	NLF	36	8	135	4-6	0.67	2	3	C	139	175	6	17	6	LPW	F
WAR DESTROYER	ADW	20	8	99/82	5-6	0.50	—	4	C	140	176	5	10	5	LPW	Y1, VH, ◆
	DWR	20	8	104	5-6	0.50	1+2	4	C	141	178	5	11	5	LPW	E, A, N1
POLICE CUTTER	POV	14	4	60/50	6	0.33	0	4	A	137	170	2	6	3	RPW	V, N, Y1
FEDERATION EXPRESS	FXE	6	2	26	3-6	0.10	—	4	AA	142	175	1	4	2	LP2	E, A, F
POD	P-SC	12	4	65/30	—	■	—	4°	—	135	165	4	+5	+1	LPW	N5, ◆
	P-HVL	16	2	48/36	—	△	0+14	4°	—	136	181	4	+3	+1	LPW	V, H, ◆, D%, N5

Class	Ship Type	G9.0 Crew Units	D7.0 Brdg Prts	S2.1 BPV	C6.5 Break Down	C2.12 Move Cost	J1.42 Spare Shuttles	R0.6 Size Class	C3.3 Turn Mode	Rule Number	Year In Service	C13.3 Dock Points	D5.2 Explos Strength	F&E Cmd Rating	War Ship Status	Notes
R3.0 KLINGON EMPIRE																
D7 BATTLE CRUISER	UD7	47	16	150/100	5-6	1.00	1+2	3	B	156	179	7	16	9	LPW	V, P, ♦
D5W NEW HEAVY CRUISER	ADW (AD5W)	45	12	160	5-6	1.00	1	3	B	152	180	7	21	8	LPW	E, A
D5 WAR CRUISER	FD5	40	8	130	5-6	0.67	1	3	B	158	173	6	19	6	LPW	F
F5W WAR DESTROYER	FWP (F5WP)	28	12	95/85	5-6	0.50	—	4	A	157	177	4	11	4	LPW	Y1, P, ♦
F5 FRIGATE	F5T	22	4	76/41	4-6	0.50†	—	4	A/D	145	155	4+2	9	4	LPW	TG
E4 LIGHT FRIGATE	E4S	14	6	64/44	4-6	0.33	—	4	A	153	134	3	7	3	LPW	♦
POD	E4T	14	4	60/25	4-6	0.33†	—	4	A/D	154	121	3+2	6	3	LPW	TG
	P-HF12	4+6	0	30/10	—	■	—	4°	—	160	178	3	+0	+0	LPW	
	P-PT13	4+10	0	30/12	—	■	—	4°	—	161	179	3	+0	+0	LPW	
	P-M11	10	3	15/13	—	■	0+2	4°	—	159	172	3	+1	+1	LPW	V, D%, N2
R4.0 ROMULAN EMPIRE																
SUPERHAWK	SUU	42	8	183/125	5-6	1.00	1+2	3	C	127	184	8	18	9	LPW	P, V, ♦
FARHAWK	FAB	40	8	166/120	5-6	1.00	1+4	3	C	129	173	8	17	8	UNV	V
FIREHAWK	FAK	40	8	180	5-6	1.00	1+4	3	C	128	171	8	20	8	UNV	V
KING EAGLE	FHM	40	12	189	5-6	1.00	1	3	C	130	178	8	21	8	LPW	E, A
KD5R WAR CRUISER	HSE	18	4	133/113	5-6	1.00	1	3	D	132	174	5	16	8	LPW	♦, *
SPARROW HAWK	KDS (KD5S)	36	8	147/127	5-6	0.67	1	3	B	131	177	6	15	6	UNV	♦
SEAHAWK	FSP	36	10	145	5-6	0.67	1	3	B	134	175	7	17	6	LPW	F
	SHH	16	4	90/45	6	0.33†	—	4	A/D	133	177	4+1	7	3	LPW	TG, N

Class	Ship Type	G9.0 Crew Units	D7.0 Brdg Prts	S2.1 BPV	C6.5 Break Down	C2.12 Move Cost	J1.42 Spare Shuttles	R0.6 Size Class	C3.3 Turn Mode	Rule Number	Year In Service	C13.3 Dock Points	D5.2 Explos Strength	F&E Crnd Rating	War Ship Status	Notes
R5.0 KZINTI HEGEMONY																
BATTLECRUISER	DCS	44	20	140/110	5-6	1.00	1+2	3	C	106	178	7	18	9	LPW	V, P, ◆
MEDIUM CRUISER	CMF	33	12	130	5-6	0.67	1	3	B	109	173	6	17	6	LPW	F
WAR DESTROYER	DWP	28	8	90/70	5-6	0.50	—	4	B	108	178	5	10	4	LPW	Y1, P, ◆
	DWT	28	8	100/72	5-6	0.50†	1	4	B/D	113	182	5+2	11	4	LPW	TG
FRIGATE	FFT	20	6	68/50	5-6	0.33†	1	4	A/D	107	122	4+2	8	3	LPW	TG
POD	P-F11	4+4	0	19/5	—	■	—	4°	—	111	178	3	+0	+0	LPW	
	P-PF12	4+8	0	19/5	—	■	—	4°	—	112	181	3	+1	+0	LPW	
	P-S10	12	4	20/12	—	■	—	4°	—	110	168	3	+4	+1	LPW	◆
R6.0 GORN CONFEDERATION																
BATTLECRUISER	DCS	50	20	180/130	5-6	1.00	3+3	3	D	93	184	9	16	9	LPW	V, P, ◆
HEAVY DESTROYER	HDF	32	12	137	5-6	0.67	1	3	C	96	173	6	16	6	LPW	F
OLD HEAVY CRUISER	LCS	28	8	70/48	4-6	0.67	2	3	D	100	173	6	8	6	NFP	◆
BATTLE DESTROYER	PTD	24	8	95/85	5-6	0.50	—	4	B	95	178	4	9	5	LPW	Y1, P, ◆
HEAVY DESTROYER	DDT	20	6	95/60	4-6	0.50†	1	4	C/D	94	129	4+2	8	4	LPW	TG
POD	P-HF	10+8	0	30/20	—	■	—	4°	—	98	179	3	+0	+0	LPW	
	PTP	10+8	0	24/20	—	■	—	4°	—	99	182	3	+0	+0	LPW	
	SP	10	2	30/10	—	■	—	4°	—	97	165	3	+2	+0	LPW	◆
R7.0 THOLIAN HOLDFAST																
HEAVY AUXILIARY	HMT	49	10	200/75	3-6	1.00	—	3	E	58	182	9	30	6	LPU	ML, Y1
LARGE AUXILIARY	LWT	17	5	162/45	3-6	0.50	—	4	D	59	182	6	21	3	LPU	ML, Y1
DESTROYER	DDS	18	6	90/75	5-6	0.50	1	4	A	56	170	4	9	5	LPW	◆, N, Y1
	DDV	24	8	80	5-6	0.50	1+2	4	A	57	176	4	10	6	LPU	V, Y1

Class	Ship Type	G9.0 Crew Units	D7.0 Brdg Prts	S2.1 BPV	C6.5 Break Down	C2.12 Move Cost	J1.42 Spare Shuttles	R0.6 Size Class	C3.3 Turn Mode	Rule Number	Year In Service	C13.3 Dock Points	D5.2 Explos Strength	F&E Cmnd Rating	War Ship Status	Notes	
R8.0 ORION MERCHANT PROTECTIVE ASSOCIATION																	
WAR DESTROYER	DWP	24	12	90/67	6	0.50	—	4	A	55	178	4	19	5	LPW	Y1, N, P, ◆	
FREE TRADER	OPT	10	6	86/36	4-6	0.50	—	4	C	54	130	3	18	3	LPW		
R9.0 HYDRAN KINGDOM																	
COMMAND CRUISER	LHE	40	18	155/115	5-6	1.00	1+2	3	C	116	180	9	15	9	LPW	V, P, ◆	
MEDIUM CRUISER	HUN	35	12	140	5-6	0.67	1	3	B	118	178	8	18	6	LPW	F	
PEGASUS CRUISER	PGR	26	10	85/50	3-6	0.67	2+1	3	D	122	174	8	10	6	LPW	◆, Y1	
WAR DESTROYER	FDW	20	10	95/78	5-6	0.50	—	4	B	117	178	5	10	5	LPW	Y1, P, ◆	
FRIGATE	FFT	10	4	54/36	6	0.33†	1	4	A/D	115	134	4	7+4	3	LPW	TG	
POD	VHP	4+8	0	34/12	—	■	—	4°	—	120	178	4	+0	+0	LPW		
	PTP	4+8	4	34/18	—	■	—	4°	—	121	180	4	+1	+0	LPW		
	SP	10	4	30/12	—	■	—	4°	—	119	165	4	+3	+1	LPW	◆	
R10.0 ANDROMEDAN INVADERS																	
INTRUDER CRUISER	IMB	24	10	280/250	6	1.00	—	3	C	66	200	36	25	8	LPW		
CONQUISTADOR LIGHT CRUISER	CCR	20	8	192/162	6	0.67	—	3	B	65	200	12	18	6	LPW		
BATTLE STATION	BAC	40	20	400/600	—	■	—	2	—	67	185	16	57	10	LPW	◆	
COBRA DESTROYER	CBR	14	8	90/77	6	0.50	—	4	A	68	168	4	12	4	LPW		

Class	Ship Type	G9.0 Crew Units	D7.0 Brdg Prts	S2.1 BPV	C6.5 Break Down	C2.12 Move Cost	J1.42 Spare Shuttles	R0.6 Size Class	C3.3 Turn Mode	Rule Number	Year In Service	C13.3 Dock Points	D5.2 Explos Strength	F&E Cmnnd Rating	War Ship Status	Notes
R11.0 LYRAN EMPIRE																
NEW HEAVY CRUISER	NCV	46	12	140/120	5-6	1.00	2+4	3	C	95	176	8	19	9	UNV	V, D%
	NSC	40	12	166/136	5-6	1.00	1	3	C	96	178	8	19	8	LPW	Y1, ◆
	NTG	38	10	147/133	3-6	1.00†	1	3	†	97	178	8	20	8	LPW	TG, Y1
WAR CRUISER	CWF	34	10	135	5-6	0.67	1	3	B	92	176	7	19	6	LPW	F
WAR DESTROYER	DWP	27	6	94/73	6	0.50	—	4	A	91	175	5	12	5	LPW	Y1, P, ◆
	DWT	27	6	92/70	6	0.50†	1	4	A/D	93	165	5+2	10	5	LPW	TG
FRIGATE	FFT	18	4	66/45	6	0.33†	1	4	A/D	94	166	4+2	7	3	LPW	TG, Y1
POD	P-SC12	10	4	30/15	—	■	—	4°	—	98	168	3	+3	+1	LPW	◆
	P-FR13	4+6	0	30/10	—	■	—	4°	—	99	178	3	+0	+0	LPW	
	P-PT14	4+10	0	30/12	—	■	—	4°	—	100	179	3	+0	+0	LPW	
PALLET	PAL-PTT	4+10	0	36/15	—	■	—	4°	—	102	179	5	+0	+0	LPW	
	PAL-SC	13	4	36/12	—	■	—	4°	—	101	168	5	+2	+1	LPW	◆
R12.0 WYN STAR CLUSTER																
HEAVY CRUISER	DSC	42	16	150/110	5-6	1.00	2+4	3	C	51	187	10	16	9	UNV	V, P, D%, ◆
WAR CRUISER	CWF	36	12	145	5-6	0.67	2	3	C	52	185	7	19	6	UNV	F

Class	Ship Type	G9.0 Crew Units	D7.0 Brdg Prts	S2.1 BPV	C6.5 Break Down	C2.12 Move Cost	J1.42 Spare Shuttles	R0.6 Size Class	C3.3 Turn Mode	Rule Number	Year In Service	C13.3 Dock Points	D5.2 Explos Strength	F&E Cmnd Rating	War Ship Status	Notes
R13.0 INTERSTELLAR CONCORDIUM																
HEAVY CRUISER	DCS	48	16	240/170	5-6	1.00	1+2	3	D	83	184	10	20	9	LPW	V, P, ♦
LIGHT CRUISER	CLF	36	12	163	5-6	0.67	2	3	C	87	184	6	19	6	LPW	F
	CBR	36	12	175/115	5-6	0.67	2	3	C	88	189	6	16	6	LPW	F
DESTROYER	NDD	34	12	110	5-6	0.67	2	4	B	84	189	6	16	6	LPW	
	DDP	24	8	93/72	6	0.50	—	4	B	86	179	4	10	4	LPW	Y1, P, ♦
FRIGATE	NFF	28	10	88	5-6	0.50	1	4	A	85	189	6	13	5	LPW	
LIGHT POD	P-LPT	4+10	2	21/6	—	■	—	4°	—	94	185	3	+0	+0	LPW	
	P-LHF	4+6	0	25/5	—	■	—	4°	—	93	179	3	+1	+0	LPW	
	P-LSC	8	2	24/3	—	■	—	4°	—	92	176	3	+3	+1	LPW	♦
POD	P-PTT	4+10	0	15/6	—	■	—	4°	—	91	185	3	+1	+0	LPW	
	P-HFR	4+6	0	25/5	—	■	—	4°	—	90	179	3	+1	+0	LPW	
	P-SC	10	4	37/15	—	■	—	4°	—	89	165	3	+3	+1	LPW	♦
R14.0 LYRAN DEMOCRATIC REPUBLIC																
MILITARY POLICE	MPT	24	4	80/63	6	0.50†	1	4	A/D	46	169	4+2	9	3	LPW	TG
	MPP	12	2	80/60	6	.50	—	4	A	47	175	4	9	3	IMP	P, ♦
R15.0 SELTORIAN TRIBUNAL																
HEAVY CRUISER	DCS	56	20	150/120	4-6	1.00	1+2	3	D	35	185	8	17	8	LPW	V, P, ♦
NEW HEAVY CRUISER	NSC	40	10	167/125	4-6	1.00	1+1G	3	D	36	185	8	19	8	LPW	♦
LIGHT CRUISER	CLS	43	20	140/100	4-6	0.67	1+1G	3	D	37	185	7	15	8	LPW	♦
DESTROYER	DDP	25	10	98/70	4-6	0.50	—	4	C	38	182	5	11	4	LPW	Y1, P, ♦
R17.0 VUDAR ENCLAVE																
HEAVY CRUISER	DCS	51	16	160/110	5-6	1.00	2+4	3	C	37	185	10	15	9	UNV	V, P, ♦
WAR DESTROYER	DWP	27	8	105/72	5-6	0.50	—	4	B	38	179	5	10	4	LPW	Y1, P, ♦