

KILLER

The Game of Assassination



STEVE JACKSON GAMES

KILLER

the game of assassination . . .

by Steve Jackson

cover by Carl Anderson

interior illustrations by Denis Loubet

additional illustrations by Jeff George and Kyle Miller

with an afterword by John W. Johnson, Assistant Professor of Folklore, Indiana University

typography and layout by Monica Stephens

production by Carl Anderson and Jeff Koke

Copyright © 1981, 1985, 1992 by Steve Jackson Games Incorporated. All rights reserved.

Killer is a registered trademark of Steve Jackson Games Incorporated.

Third Edition

*The author would like to express his appreciation to the many people behind this book, in the order in which their contributions were made. First, Robert Sheckley, whose story, "The Seventh Victim," started it all. Second, the many spies and playtesters who helped me to collect the material in this book, separate the wheat from the chaff, and get it all down on paper. Their names have been omitted to protect the guilty! Third, Professor John William Johnson, both for writing the afterword and for his aid in research. And finally, the various fiends and maniacs who contributed ideas after reading the first edition of **Killer** – especially Mike Stackpole, who really got into the spirit of things and sent several useful suggestions, and Jeff Koke, who wrote the Hidden Prize scenario.*



**A live roleplaying game
for any number of players**

INTRODUCTION

"There's nothing like the thrill that you get from wiping out a friend."

– Shelley Berman

Competition is the essence of any game. From tic-tac-toe to chess, from *Snakes and Ladders* to *Monopoly*, from toy soldiers to the most realistic wargames . . . the object is to triumph by eliminating your foe. Conflict and competition are basic to human nature; argument to the contrary is wishful thinking. And, after all, competition is only part of the struggle for excellence that has taken man to the Moon and beyond. People *like* competitive games.

And, throughout the history of games, the tendency has been toward more realism. The introduction of roleplaying games brought a new level of immediacy to gaming. No longer did the player control faceless armies . . . now *his own character* could fight dungeon monsters or alien space-raiders. But even in a roleplaying game, the players still spend hours sitting around a table, rolling dice and looking up rules. Sometimes that's not enough. Some of us want more!

Killer is that "something more." In *Killer*, you don't create a paper character . . . you *are* the character. Players match skills and wits on a personal level. It's all a game – while it lasts, it's real. The object of *Killer* is to eliminate the opposition by fair means or foul . . . usually foul! Under the supervision of a game master, players attempt to score "kills" with dart guns, confetti "grenades," balloon booby-traps, and dozens of other ingenious devices. The survivors win.

"Assassination" games are not new – they've been around for years (see the *Afterword*, p. 59). But this book is the first set of full-scale written rules for such a game. It also includes safety precautions . . . in the hope that those of you who are already playing "assassination," in one form or another, will take some time to think about safety. *Killer* is a great game – IF you play it right!

Good luck – and watch your back.

– Steve Jackson

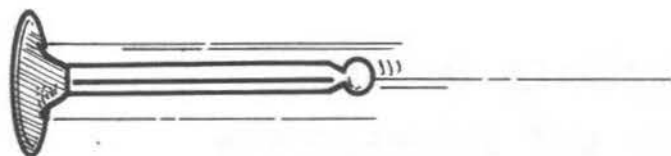

Disclaimer

Players are encouraged to play this game in a reasonable and sensible fashion. Because the information and suggestions in this book may be used in circumstances outside their control, the author and publisher assume no responsibility for any loss or injury occasioned by such use.

CONTENTS

<i>Introduction</i>	2
<i>Contents</i>	2
<i>Basic Rules</i>	3
<i>Weapons</i>	12
<i>Primitive Weapons</i>	13
<i>Modern Weapons</i>	17
<i>Bombs</i>	22
<i>Poisons</i>	31
<i>Futuristic Weapons</i>	34
<i>Fiendish Fantasy</i>	37
<i>Exotic Murders</i>	38
<i>Group Attacks</i>	40
<i>Scenarios</i>	41
<i>Killer At Conventions</i>	52
<i>The Compleat Killer</i>	54
<i>Other Real-Life Simulations</i>	57
<i>Afterword</i>	59
<i>Buttons</i>	60
<i>Contract</i>	61
<i>Death Certificates</i>	62
<i>Weapon Table</i>	63
<i>Index</i>	64

BASIC RULES

The GM

The GM (game master) is the organizer and referee of a game of *Killer*. A GM may wish to adopt some sobriquet, such as “Number One,” “Central,” “The Administrator,” etc., to sign documents. If a game is run by a group of GMs, they could be referred to, collectively, as “The Committee.”

The GM is responsible for organizing the game, filling out the Contract specifying the exact rules to be used, and assigning the original targets and victory conditions. During the game, the GM should be available to answer questions, make rule decisions, and solve any other problems that come up. If the game requires a central bulletin board, the GM should make sure it is kept up to date.

All players should have the GM’s telephone number, and the GM should keep a list of the names, addresses, and phone numbers of everyone in the game. He will then be able to contact players quickly to inform them if (for instance) their “target” changes. The GM may also wish to keep a “status chart” for the game, showing who is still alive, who has killed who and how, etc. This is by no means mandatory – if the GM keeps such a chart, it should be well hidden from prying eyes so that players don’t learn who else is in the game. The GM is the only person who knows everything that is going on. It can be just as much fun to GM a game of *Killer* as to play!

The GM may declare anyone dead (or alive) at any time, for any reason. He or she is the final authority in the game.

Needless to say, the GM may not be killed.

Who Can Play?

Killer is an *adult* game. “Adult” doesn’t have as much to do with age as it does with common sense. Some ten-year-olds have a lot of common sense; some 40-year-olds have none. Playing this game without common sense can get you into a lot of trouble – see *Legal Matters*, p. 57.

Thus, when the GM first sets the game up, he should admit only players who are adult enough to play *safely* and within the rules. This will vary depending on the scenario. If you’re playing with rubber bands in broad daylight in the city park with no innocent bystanders around, you can probably let the kids get in on the fun.

Likewise, the GM must make it very clear to players that children and/or idiots can’t be admitted as recruits or accomplices. Players are responsible for the people they bring in, and the GM is responsible for everybody.



Starting the Game

A game begins when a GM organizes it – or when a group gets together and chooses a GM. It is possible to post an announcement of a meeting for potential players. This can give away the identities of the players, though, so private talks with the GM may be better.

Before starting play, you must decide:

- (a) General nature of the game scenario.
- (b) Beginning time.
- (c) Ending time (or ending conditions).
- (d) Prizes, if any.
- (e) Name/address of the GM.
- (f) Location of the game bulletin board, if any.

The details of the Contract (see below) may be settled then, or left to the GM to finalize and post. The game must NOT begin until all players have had a chance to look at the Contract, since it contains *all* the rules, limits, weapons, etc., being used in that particular game. It is best if each player has a copy of the Contract *and* a copy of this game book.

Ending the Game

A game may run until a predetermined date, or it may go on until some specific condition is met (such as only one person being left alive!). If a game does not have a predetermined ending date, the GM should post the announcement that the game is over, and/or phone all players, as soon as possible. This will avoid unnecessary bloodshed.

The Contract

The Contract is the document which empowers the players to kill each other. It is drawn up before the game by the GM (or the Committee), and sets out exactly when, how, and why the players may engage in mutual slaughter. See p. 61 for a blank Contract form, which players are welcome to copy and use.

The Contract should cover all the following:

1. The Scenario being used. Is this a roleplaying game?
2. GM's name, address, and phone number – plus times when he may be called.
3. Location of game bulletin board.
4. Allowable weapons. These may be specified by time period, by class, or just by a list of the legal weapons.
5. Will the GM (possibly) OK other weapons during the game, or are the ones listed the *only* ones players must look out for?
6. Boundaries of game area, and/or off-limits areas.

7. Starting and ending dates of game.
8. Hours during which assassination is legal.
9. Witnesses required/permitted?
10. Is wounding legal, or is this a “straight kill” game?
11. Do players have more than one life each?
12. Is money being used? If so, attach a price list for weapons, etc.
13. OPTIONAL: A list of players in the game.
14. Are accomplices legal?
15. Is recruitment possible – that is, can new players enter after the game starts? If so, who can be recruited?
16. If the point schedule differs from that in the book, specify.
17. If any special rules are being used, specify.

The Bulletin Board

It is a very good idea for the GM to establish a bulletin board for game news. This should be in a public place and accessible 24 hours a day (or as close to that as possible). The GM may declare the area within 50 yards of the bulletin board to be “off limits,” or he may speed up the game by allowing murders at the board! Either way, the availability of a bulletin board will reduce the number of phone calls the GM has to make.

The bulletin board may be used for posting:

- (a) names of people killed;
- (b) names (and photos?) of new entries in the game;
- (c) a complete copy of the Contract;
- (d) rule changes with their effective time;
- (e) announcements of cumulative scores;
- (f) “news reports,” composed by the GM or an assistant, detailing particularly ingenious or messy killings, or any other news the GM thinks should be public property;
- (g) challenges for duels, and other messages between players;

and anything else the GM or players need to announce. Anyone may put up anything they like on the bulletin board, but **ONLY THE GM** may remove notices.

A computer-operated telephone “bulletin board system,” or BBS, is *perfect*, if all players have access to modem-equipped computers.

Off-Limits Areas

Certain areas should be off-limits in *any* game. No killing may take place in *or from* an off-limits area; if it occurs, the victim is alive, and the killer is out of the game.

Off-limits areas should include:

- (a) Public restrooms for the opposite sex.
- (b) Classrooms while a class is in progress.
- (c) Churches, etc., while services are in progress.
- (d) Judicial or legislative chambers, or police stations.
- (e) Hospitals or infirmaries.



(f) Moving automobiles or vehicles of any kind – or vehicles of any kind that are stopped in traffic.

GMs may declare any other areas off-limits for any reason. Such off-limits areas should be noted on the Contract at the beginning of the game. If necessary, additional off-limits areas can be posted on the bulletin board during the course of the game.

A common “off-limits” provision is a rule stating that no assassin may enter a victim’s residence unless the victim (NOT another person) invites him in. An assassin assigned to kill his roommate, of course, may enter freely.

Players in an off-limits area may discuss the game and make plans, but NO action of ANY kind is permitted. Players may not attack in any way, including indirectly; that is, you may not plant a bomb, poison, or other death-trap on a player while he is in an off-limits area. It is also against the rules to attack *from* an off-limits area *to* a legal one, or vice versa.

Time Limits

The GM may set any time limits necessary for the game. These should be noted on the Contract at the beginning of the game.

A game may be set to run for a specified number of days, or go on forever (or until one side wins). Likewise, in an “assassination” scenario, players may have only a set amount of time to complete each assassination once they know who their victim is.

The GM may also declare that the game will only be played for part of the day . . . for instance, between noon and 10 p.m. This can be a good idea in an environment (e.g., school) where players require a little peace and quiet part of the time.

Dropping Out Of The Game

A player may leave a game of *Killer* at any time. One showy way to do it is to stage a public “suicide,” either by acting it out or by posting a note on the bulletin board explaining that you have taken your own life (in remorse for your murderous deeds?). If you’re not interested in drama, just phone the GM and say that you’re dropping out. He can notify your assassin and enemies. This will keep them from wasting their time . . . and you no longer have to look into every room before you enter.

Recruitment ***(Joining The Game)***

Some scenarios allow players to enter the game after it has already begun. This is called “recruitment.” To be recruited, a player must find a team that will accept him (usually, they will be glad to!), and get the permission of the GM. The GM will see that the new player gets a copy of the Contract. If possible, the new player should have his own copy of this book. Depending on the scenario, the GM may then announce the new player’s participation on the bulletin board, place a “news item” hinting at the recruitment without giving details, or keep it a total secret.



Secrecy

In general, it is in each player’s interest to keep other players from finding out that he is in the game. Forewarned is forearmed: anyone known to be in the game will automatically be suspected of foul intentions by all the other players.

Specifically, though, it is *illegal* for a player to tell anyone (except the GM) about the circumstances *under which he died*. Wait until after the game is over! The reason is simple: dead men tell no tales. If someone assassinates you, and does it cleverly enough to leave no evidence, it would be unfair to *him* if you immediately broadcast the details. Not only would the other players then know he was in the game – they would have a good idea of his position and/or affiliation.

Witnesses to a killing are perfectly free to talk, though. This is another good reason to avoid witnesses, even if your Contract permits you to kill in public. One talkative witness can totally ruin your cover.

The GM may penalize an over-talkative player in any way he sees fit. Since he/she is dead, sanctions may be limited – but it is easy (and a good idea) to exclude a blabbermouth from later games.

Accomplices

An accomplice is someone who aids an assassin but does not actually carry or use weapons. The Contract for a particular game will specify whether accomplices are legal.

Your victim will not be able to attack your accomplices (legally), because they will never wear masks or hold weapons. Killing an accomplice carries the same penalties as killing a bystander (see below).

Possible uses for accomplices include:

- (a) spotting your victim to allow you to trigger a bomb or move in with a hand weapon.
- (b) distracting your victim or luring him out of his place of safety.
- (c) carrying messages between members of a team of killers.
- (d) shouting “There he goes!” and pointing in the wrong direction to help you make an escape. (Legally speaking, this person is an accessory rather than an accomplice, because he helps you *after* the crime has been committed. Pish and tush on such technicalities.)
- (e) checking the game bulletin board for you if it is inconvenient or unsafe for you to approach.

If the game uses money, the GM may require that you pay him a fixed sum (say, \$50) for every accomplice you “hire.”

An accomplice may *never* actually kill a player by any means – including indirect ones such as poison or bombs. A kill made by an accomplice does not count; the victim is alive, and the accomplice and/or the person he is aiding may be dead. Accomplices themselves may not be killed.

Legitimate Targets

Legitimate targets for assassination depend on the scenario, but will always include:

- (a) your assigned victim (or victims), if any. In a team scenario, anyone identified as a member of another team is a fair target.
- (b) the assassin assigned to *you*, if you learn his/her identity. See *Counter-Assassination*.
- (c) anyone you see wearing a mask (see *Masks*).

(d) anyone holding a gun or other weapon in sight. Even accidental exposure of a weapon can be construed as a “draw,” leaving the weapon-holder open to attack. However, once the weapon is concealed again, its owner is no longer a target. Thus, if you see someone running down the street with a gun, he is fair game – but as soon as he puts the gun up, he becomes a bystander (see below) and may not be harmed. Of course, anyone who saw him with a gun will know that he’s (probably) in the game, and that he must be treated with caution.

As a rule, it is never legal to kill another player unless you are after him. A player who blunders into a booby-trap that you have set becomes a legitimate target for that trap (see *Accidental Death*, below). But in most cases the GM will penalize you if your booby-traps catch anyone but their intended target. Killing bystanders is very bad form . . . see below.

Bystanders

A “bystander” is anyone not playing the game – OR anyone playing the game who is not a legitimate target.

Anyone killing a bystander may be subject to a penalty of many points – or, if no point system is being used, the GM may simply declare the killer to be dead. If you are sure that someone is your assassin, you may risk killing him. If you are wrong, of course, you will suffer the penalty. You are also advised to use a very harmless method of attack, since if he IS a bystander he may be displeased with you. Similarly, in a team game, the GM may rule that a bystander may be killed before he shows a weapon . . . but there will be a high penalty if the bystander is proved to be innocent, rather than an enemy. In general, it’s safest to leave the bystanders alone. Politer, too.

Bombers must also be careful of bystanders. If non-players or players other than legitimate targets are within the radius of a bomb explosion, the victim may report this to the GM, who will penalize the bomber accordingly.

A victim fleeing from an assassin may certainly seek the company of bystanders, either as witnesses or as cover, to save his own life. However, any tactics that deliberately endanger a bystander (such as grabbing him and using him for a shield) would be illegal, and should be strongly penalized by the GM. In general, victims must avoid “harm” to bystanders just as

much as assassins. A victim cannot use a bystander as a “stalking horse” or dummy. He also cannot get bystanders to open doors, check boxes, etc. for him. In the first place, this is not sporting. In the second place, if the bystander should set off a bomb, encounter poison, or otherwise meet a messy end under such circumstances, the *intended victim* is responsible for the death and will be penalized by the GM.

Counter-Assassination

If a victim realizes he is being attacked, he may use any legal weapon to defend himself. It is quite possible (especially if the assassin is slow, clumsy, or overly-dramatic) for the victim to turn the tables and kill his assassin. In a “combat” situation, the player who is hit *first* is dead – there are no “dying shots” or muscle-reflex trigger pulls. In a case where both players actually fire at the same time and hit each other, both of them are dead, and should report this to the GM immediately.

It may also happen that a victim is attacked unsuccessfully and finds out who his assassin is. If this happens, the victim is free to hunt the assassin just as though their roles had been reversed. If the victim can assassinate his assassin, the next step depends on the scenario. In a regular “Circle Of Death” game, the victim must simply go on trying to assassinate his *own* victim, while the person who had been trying to kill his assassin is now after *him*.

Unless you’re very fast on your feet, it’s a good idea to carry some sort of defensive weapon, against the moment when your assassin shows himself. Small pistols and blowguns are good for this. Remember: if you expose your weapon, it makes you fair game for anyone playing!

Players must be careful when defending themselves against assassination attempts. It is best to wait until there is actually a weapon in sight, just to make sure you aren’t attacking someone who isn’t even in the game.

Accidental Death

If Player A, assigned to kill Player B, sets a bomb or poison and gets Player C instead, then A does NOT get credit for a “kill,” though he incurs no penalty unless the GM feels he really intended to get C after

all. Nevertheless, C himself remains dead as a penalty for insufficient caution.

However, if Player A, assigned to kill B, pulls a gun or other weapon on C and does him in, the GM should treat the situation as though C had been a bystander. A is penalized, and C remains in the game. This discourages players from shooting each other merely on suspicion.

Clean-Up

The GM may require that each player give him a list of bombs, poisons, and other booby-traps planted during the game. After a game ends, all booby-traps must be cleaned up immediately, to avoid discomfiting non-players and to clear the area for the next game.

Self-Destruction

A player is safe from the evil effects of his own devices while he is designing and testing them. You may explode as many balloons as you like while developing the perfect trigger. When it comes down to an actual attempt, though, you *can* be blown up by your own bomb. A player who pops a balloon himself, while setting it as a bomb, should call and report to the GM that he has blown himself up. The same should hold true for an accidental self-poisoning. Reporting such an “involuntary suicide” is very much a question of honor; there is usually no way it can be enforced.

Witnesses

To add to the difficulty of the game, the Contract may specify that only a limited number of witnesses may see any assassination. A “witness” is anyone old enough to talk who is in a position to see the deed. In a case of any dispute, the GM’s decision is final. The question to be asked is “If this had been a real murder, could that person testify in court?”

If the Contract specifies zero witnesses, killings will be very difficult. Allowing one or two is more workable.

If a killing is accomplished *in absentia* – by a bomb or poison – then witnesses do not matter. Note, though, that if a bomb is used, bystanders may be killed – so a “witness” situation is still to be avoided.

If the killing is done with a camera, witnesses at the victim’s location do not matter, but witnesses at the assassin’s site are to be avoided.

If an assassin wears a mask, witnesses do not matter. However, masks have their own hazards – see below.

Alternatively, a scenario may *require* one or more witnesses to any killing – see the section on *Death Certificates*.

A victim who defends himself by killing his assassin does not have to worry about witnesses – he acted in self-defense. A victim who has learned his assassin’s name and sets out to counter-assassinate him must follow the same witness guidelines as for an ordinary assassination.

Masks

Masks are only important in a game where assassinations must be performed “secretly” – that is, with few or no witnesses. If an assassin wears a mask, his identity remains a secret no matter how many people see the killing. However, the potential victim will probably be alarmed by the sight of a masked figure. Furthermore, a masked person is a fair target for anyone in the game . . . see *Legitimate Targets*, above.

Any kind of mask is legal – a domino face-mask, a Halloween mask, a bandanna tied over the face, or anything else you can come up with. The mask must be put on when no one can see you, and worn until you can take it off in similar privacy. Thus, to wear a mask is to court danger.

Sunglasses are *not* a legal mask. Too many non-combatants will be wearing sunglasses . . .

Wounding

The possibility that a player may only be wounded, rather than killed, adds complexity to the game. It also slows things down. The Contract for a game must specify whether wounding is allowed. If no wounding is allowed, any hit with a legal weapon is an *automatic* kill.

For each weapon, there is a “chance of wounding” shown on the Weapon Table. This is determined by rolling a six-sided die. K equals kill, W equals wound, M equals total miss. For instance, a grenade (if these rules are used) kills on a 1 through 4, wounds on a 5, and misses on a 6. Some weapons never miss.

When an attack takes place that *could* result in a wounding, the victim is considered incapacitated immediately. He may not fire back at his attacker; neither may the attacker continue the attack to pile up possible wounds. As soon as possible after the attack, the victim must phone the GM. The GM will roll a die and inform the victim whether he is dead, wounded, or hale and hearty. The killer must find out however he can. (If his victim is dead, and a bulletin board is being used, there will be an announcement.) But often a killer may not be sure whether he has gotten his victim, at least for a while, if he uses any but a “sure kill” method.



Gun-type weapons that mark the victim (e.g., water guns) use a different system. Any hits to the body (or head, if using a harmless weapon) are automatically kills. Any hit to the arm or leg is a wound. Multiple wounds have no cumulative effect. (Or, alternatively, the GM may rule that a second wounding is a kill.)

A wounded player may NOT attack another player in any way. He may defend himself against attacks by hiding, running, etc., normally, but may not counter-attack. He may communicate freely with other players, and may act as an accomplice – but he IS a legal target while doing so.

The effects of wounding last until midnight of the *next* day of the game. At the end of that time, the “wound” vanishes and the player may participate fully.

Wounding is a good rule to add in a “team” game, especially one where not all the players know each other. It is not a good rule for a “circle of assassins” type game . . . it only slows things down.

Wounded players may be required to wear a button or name-tag saying “WOUNDED,” to advertise their status to anyone who sees them.

Duels

Any player may challenge any other player to a duel at any time. The challenge does *not* have to be accepted (though in some games you lose points for declining a challenge). Either player may attempt a dirty trick before or during the duel; therefore it is customary to bring a “second” to watch your back and make sure the proprieties are followed.

A duel may be refereed by the GM, his chosen deputy, or any other person agreeable to both sides. The referee should probably not be a player, since he might then be tempted to kill *all* the participants. If one side can bribe the referee . . . that’s the way the bomb bounces. The GM, of course, will not take bribes.

Any duelling weapons acceptable to both parties may be used. The commonest duelling weapon is the pistol. Dart guns, with three flour-tipped darts each, are excellent for settling affairs of honor. (Another traditional duelling weapon is the rapier. This should NOT be used unless both participants *and the referee* have genuine fencing experience and all necessary protective equipment!)

Duels are best in team-type games, and may even be used to settle a dispute between members of the same team. Duels are absolutely essential to the Renaissance version of *Killer* (see p. 48).

Money

Money may be added to almost any scenario. The GM should issue scrip representing money, giving each player (or team) a certain amount. He may even allow players to “earn” more money as the days go by. The money should be uncounterfeitable, as far as it is within the GM’s ability to arrange this. If players can counterfeit money well enough to fool each other or the GM . . . they deserve to get away with it.

Money can be used in several ways:

(1) Buying weapons. The GM is the source of all weapons, and each weapon has a fixed cost. (Players taking weapons from downed foes may keep them in this instance, reporting the fact to the GM.)

(2) Inter-player negotiations. Players may bribe each other for assistance (or to let each other alone).

(3) As a victory condition. In addition to staying alive, players may have the objective of accumulating as much cash as possible.

The GM may rule that a player must carry all his money on him at all times, or that money may be hidden elsewhere. If killed, a player must give all money in his possession to his killer(s). Any money he has hidden is lost, unless its hiding place is *already* known to another player. A dead player may not reveal the location of his hoard to anyone but the GM.

Point Systems

In the simplest games of *Killer*, there is no worrying about points. The winner is the last survivor, and that's that. As players become more skillful, a point system may be used to encourage cleverness, loyalty, and finesse. A point system is also needed if *Killer* is played as a roleplaying game – see the next section.

The GM may keep point totals secret till the game's end, or post them daily.

As always, the GM has the last word about points. In general, they should be awarded as follows:

Each assassination performed – 20 points.

Wounding a target but not killing him/her – 5 points.

Great bravery in performing an assassination – 10 points extra.

Use of an exceptionally ingenious device in a successful kill – 10 points extra.

Exceptional treachery or duplicity in a kill – 5 points extra.

Dying in a very realistic or artistic fashion – 5 points extra.

Each \$10 (game money) you end the game with – 1 point.

Being the last survivor (or on the winning team) – 40 points.

Points may also be deducted by the GM, as follows:

Poor sportsmanship – minus 10 points (or worse).

Dangerous behavior as a victim OR assassin – minus 20 points (or worse).

Attacking a non-combatant – minus 40 points and/or death.

Attacking outside time limits or in an off-limits area – minus 40 points and/or death.

Special point-values for other actions will be given in some scenarios. As will be seen, it is possible for one player to be the last survivor in a game, yet lose on points if another player had a better overall performance.

Roleplaying

In a roleplaying game, each player adopts a name, background, and personality other than his own. Players may adopt aliases in any game, the better to terrify and confuse their foes. True roleplaying, in which players get extra points for acting “in character” and lose points for acting out of character, is best in a team game.

Each player should adopt a personality type, as described below. Each type has its advantages and disadvantages. The GM may invent other personality types, but no one type should be “better” than the others.

Loyal

Gets points for bravery in an assassination attempt (GM's decision) even if kill is unsuccessful. Never gets points for killing anyone on his own team unless they were attempting a treacherous attack on other members of the team. 30-point bonus for dying “in the line of duty.” 10-point penalty for taking a bribe (the enemy who bribes him should report this to the GM).

Treacherous

10 extra points for any sneaky method of killing (GM's decision). 5 extra points for killing a member of his own side. 10 extra points for getting an *enemy* to kill a member of his own side (unless that killer is *also* treacherous).

Glory-Hungry

Gets points for bravery in an assassination attempt (GM's decision) even if kill is unsuccessful. Gets 5 extra points for any kill of member of opposing side. 20-point bonus for dying in the line of duty (i.e., attacking a foe or defending a friend).

Money-Hungry

All money counts double for points. (This type may be combined with any other type. It isn't an unmixed advantage . . . if you are known to be money-

hungry, people will offer you bribes, and you will be less likely to spend money when you need to!

Maniacal

10 extra points for any unusually horrible method of killing (GM's decision). 10-point penalty for killing in any ordinary fashion (e.g., guns). (This type may be combined with any other type.)

Brave and/or Stupid

Must inform ALL opponents of his name and address (photo optional) at beginning of game. 25% bonus on *all* points scored during game. (May be combined with any other type.)

Cowardly

Loses points for any action the GM construes as "brave." May not challenge another player to a duel. Gains 10 extra points for shooting someone in the back. NO extra points for killing with a bomb (bombs are dangerous) but 5 extra points for killing with poison. (May be combined with any of the above except "loyal" and "glory-hungry.")

In addition to the above point values, the GM may award additional points as he sees fit when players do a very good job of staying in character, and *subtract* points when they break character.

Players may also wish to take on aliases appropriate to the scenario being played, and to stay "in character" as much of the time as possible during game hours. In a Chicago-1920 game, one side might be composed of Godfather Don Vito Fettucini, his lieutenant Luigi Scallopini, and the button-men Guiseppi Verticelli and Tony (the Chicken) Cacciatori. In an espionage scenario, players would all be referred to by numbers, which might change at any time. When discussing the game, players should refer to each other by their game names; this adds greatly to atmosphere and confuses listeners no end.

Zen Killer

This is the most non-violent version of all . . . and perhaps the spookiest. It's entirely in your heads.

The GM sets up a group of players, and assigns each one a victim, as in the normal "Circle of Death" scenario. But no one makes any attempt to actually

"kill" their victim. All they do is *plan*. The point of the game is to come up with the best murder *plot*.

Each player has the same budget for time and money. If the time budget is a year, for instance, the plan must be something that could be finished in a year. The more time and money everyone has, the more elaborate the plans will be. "A million dollars and a year" will give some really involved schemes. "\$100 and 3 days" will give results that look entirely too much like today's newspaper.

The GM sets the time limit for turning in the finished plan – say, a week. The plan must go into as much detail as possible, with contingency plans for everything the killer can think of.

When all plans are in, the GM scores them. We'd suggest rating them on a 0-10 scale for each of the following:

Cleverness. Blowguns, daggers made of ice, and robot-controlled bulldozers will score much higher than "I ring his doorbell and shoot him when he answers."

Workability. That is, how likely is it that the victim will really end up dead? Having contingency plans is a big help. But any plan that starts off "First I get elected President" scores a 0 here. Also, sadly, the cleverest plans may be the least workable.

Indetectability. This should count double. How likely is the killer to get away with it without being caught? Or, if he gets caught, how likely is it that there will be any real *evidence*?

If it's Halloween, add another possible 10 points for gruesomeness!

Warning: Discussing your murder plans in public, or leaving notes where they can be found, can be hazardous to your health.

A Note On Idiots

Veteran *Killer* players have a term they use for a player who, emboldened by the possession of a brand-new water gun, goes around squirting everyone he meets. That term is "idiot."

This sort of behavior is irritating, immature, and tends to bring down public wrath on everyone in the game. While there is no cure for idiocy, the GM will want to apply his strongest sanctions against anybody who is systematically molesting bystanders as "part of the game." Throw him out.



WEAPONS

A weapon in *Killer* may be anything that simulates the action of a real weapon *in a harmless fashion*. Common examples are dart guns, water guns, “poison” tokens, and balloons. Details for these and other weapons are given on the following pages.

The GM is responsible for deciding, before the start of the game, what weapons will be legal. These should be specified on the Contract. A game may be limited to one kind of weapon, to primitive weapons only, to all Class A and B weapons, to bombs and poison only . . . whatever the GM and the killers decide. An attack with an illegal weapon is void and may result in the attacker being declared dead.

The GM may provide weapons (at cost) for all participants . . . or players may be allowed to choose and obtain their own. If players are providing their own weapons, it is a good idea to require GM approval for each individual weapon (except for Class A weapons) for safety reasons.

Each player’s weapons are the property of that player. In a “hot pursuit” situation, one player may pick up a dropped weapon belonging to another player for emergency use – but such weapons must be returned as soon as possible or delivered to the GM. Players may wish to mark weapons with their names (although, in the case of a hidden bomb, this can have its disadvantages!).

Weapon Classes

Weapons are divided into four classes: A, B, C, and D. These classes represent the safety of that particular weapon-simulator, as follows:

CLASS A: Safe. Being attacked with this weapon is safer than driving to the grocery store. Class A weapons are the best for *Killer*.

CLASS B: Reasonably safe. It is possible to hurt someone with a Class B weapon if someone is very foolish or unlucky. Precautions should be taken – for instance, if Class B guns are being used, head shots should be illegal. A weapon may also be declared Class B if it has damaging side-effects. Water balloons are Class B because they can cause property damage if thrown carelessly.

CLASS C: Risky. Protective clothing would be required to make Class C weapons safe. If you must use Class C weapons, get out in the country where you can’t clip a bystander. *Better yet, forget them.*

CLASS D: Dangerous. **DO NOT USE CLASS D WEAPONS.** The only reason these are included in the book at all is to show that they *have* been considered, and are deemed much too dangerous to use on your friends.

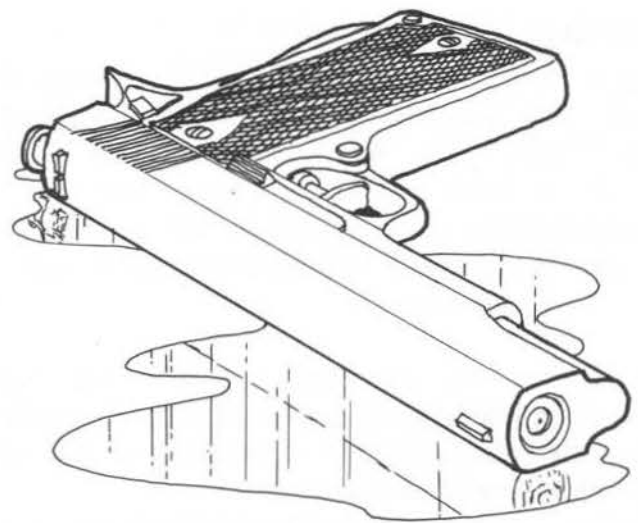

Weapon Approval

For fairness and safety, the GM should check and okay any weapon before it is used. This can be especially important if a great variety of weapon types are legal. For instance, all water guns are safe, but some dart guns are risky unless modified. *Never assume that a weapon is safe because it is sold as a “toy.”* No player should be allowed to use a weapon that he will not allow to be used on himself, and no GM should okay a weapon he would not allow to be used on *himself*. This is not the only criterion of safety, but it’s a good beginning.

In order to insure absolute uniformity of weapons, the GM may wish to purchase a number of identical weapons beforehand and supply them at cost to the players.

PLAYERS SHOULD NOT USE REALISTIC-LOOKING KNIVES OR GUNS in public areas! A fluorescent-orange dart pistol is *far* safer than a black one. The reason: If your game is witnessed by a policeman or security guard, he is unlikely to be alarmed by an obvious dart gun. On the other hand, a black or dark blue weapon, at a distance of 20 feet, can look frighteningly real. And it's not a good idea to upset people who carry *real* guns. As a matter of fact, it could be fatal! *Don't risk it.*

Approval of New Devices

The Contract may specify that certain weapons are legal, but others may be okayed during the game. This simply means that the GM reserves the right to permit a new weapon to be used (even one the other players have never heard of) if it seems safe and clever. The

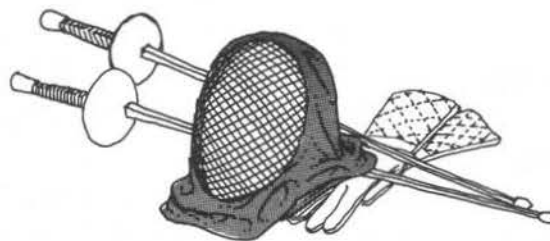

advantage of this rule is that it encourages creativity and keeps the game interesting . . . players never know what they'll be faced with next, because it may not be in the book. The disadvantage is that players may not recognize a new device as a weapon, and therefore may not die when it hits them. Weapon inventors should keep this in mind when designing new implementations of destruction.

PRIMITIVE WEAPONS

Knives

Foam or Soft Rubber Knives **Class B**

The only danger with these weapons is that they may lead to rough body contact as two people wrestle for a knife. If you don't mind this – or if the GM simply outlaws grabbing for a knife – then there is no objection. Only very soft knives should be used. A knife may be tipped with powdered chalk to show where it strikes. Knives (except throwing stars) should not be thrown; a knife soft enough to be safe probably won't throw accurately.

Collapsing Stage Knives **Class B**

These are realistic-looking knives in which the blade retracts into the handle. Hard to find, but fun. *Do not carry in public areas!* Use as above.

Throwing Stars **Class B**

The Japanese *shuriken*, or “throwing star,” can be represented by a piece of heavy foam, cut to shape. Throw it with a flipping motion. Like the real throwing stars, these are easy to hide. A poker chip makes a

quick substitute version, but do *not* aim for your victim's head!

Any knife may be poisoned – see *Poison*, p. 31.

Bows

Light Bows **Class C**

There is no way to make any bow really safe to use against an unprotected person. For a game played away from innocent bystanders, *very light* bows (under 20-pound pull) have been used along with arrows modified to have heavy, soft tips. Head shots are still hazardous – in fact, a fencing mask is a *must* if you do this at all.

Blowguns

Fluff Blowgun **Class A**

This is a large tube which “shoots” a ball of fluff. Accurate up to about 10 feet; the fluffball can be dusted with chalk to mark hits. Treat the fluffballs as poison darts, and take appropriate precautions – see

below. However, the weapon itself is entirely harmless.

Peashooter

Class B

The peas may be poison darts – this is appropriate in any scenario, from primitive to advanced. *Do not use real darts!* Head shots should be avoided. Note that since poison darts are being simulated, the killer may not go around with a mouthful of peas. He may have at the most three darts, which must be kept in a box in his pocket. A pea may only be put in the blowgun when it is about to be fired. A disguised blowgun (cigarette, pen, etc.) is a good ploy.

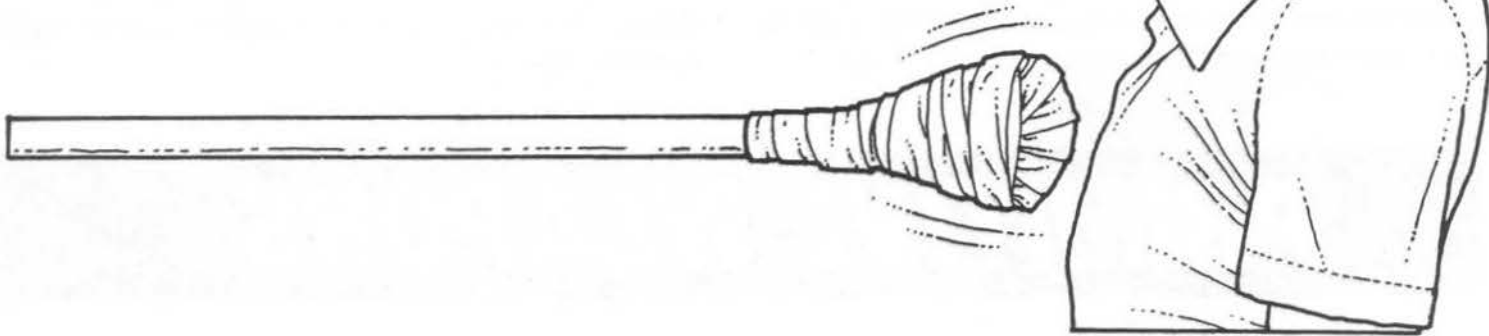

Spears

Boffer Spears

Class B

These can be made from plastic golf-club tubes. Duct tape is then used to put a heavy ball of soft foam on the end. This device is fairly safe, but impossible to hide.

towel is another good boffer. To score a kill with a boffer, one must hit the victim on the *body* with it. Since a boffer is impossible to hide, this must be accomplished by stealth or surprise.

Clubs and Axes

Rolled Socks

Class A

These make very handy simulated blackjacks. A tap on the head or neck is sufficient to stun a victim; you may then dispose of him at your leisure. **DO NOT** put anything in the sock except (perhaps) another sock. That would make it a *real* blackjack, which can really injure someone.

Garrotes

Hands

Class A

Put both hands on the victim's *shoulders* from behind, squeeze, and say "Gyeeeeeeech" or something equally throat-curdling. *Don't* actually grab somebody's neck; that could provoke a violent reaction.

Boffers

Class B

It is *almost* impossible to hurt someone with a boffer, but it can happen on a bad day. A boffer is simply a length of soft foam, which may be wrapped with duct tape to make it smoother and stronger. A rolled-up

Silly Putty or Toilet Paper

Class B

A soft material like this, formed into a thin string, can be looped around a victim's neck from behind and pulled tight. If you succeed, your victim is dead. The only real danger in this method of attack is to the *attacker*. If your victim has quick reactions and sharp elbows, you may get bruised or worse. Be careful.

Animals

Paper Snakes/Spiders/etc. Class A

An *unrealistic* drawing of a venomous creature, or just a note saying "This is a snake," may be placed where it will fall on the victim, or where the victim will encounter it unexpectedly. The bed is a good place. This ploy may give your victim the creeps, but it won't frighten him/her too much.

Rubber Snakes/Spiders/etc. Class B

The danger in using one of these is that your victim may be one of the small minority of people who go into hysteria at the sight of such creatures. If you *know* that he/she isn't afraid of them, that's better.

Real Snakes/Spiders/etc. Class D

Don't! The danger of hysteria or real injury is much greater, and the innocent beastie is certainly going to wind up dead.

Fish Class A

The victim, or someone close to the victim, must keep tropical fish. A note is placed on the back of the



aquarium, saying "Piranha." Now all you have to do is induce the victim to reach into the tank . . . If you are using "wounding" rules, this would only be a wound, but it would still be worth points for fiendishness.

The problem of stocking a whole *pool* with these imaginary piranha is left up to the reader. Don't use goldfish; the chlorine would kill them. Pool toys, maybe?

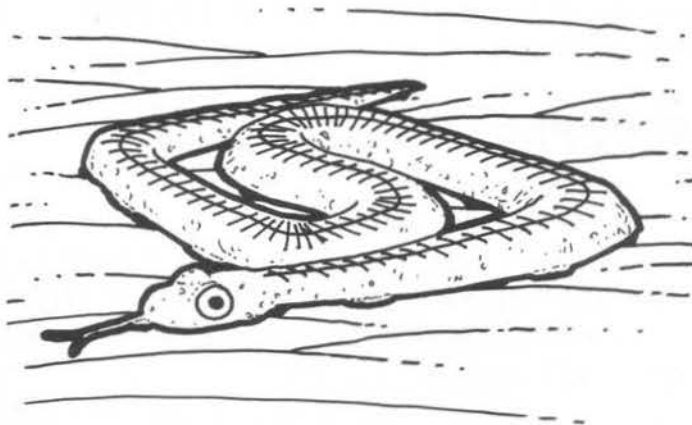

Killer Bees Class A

A "bomb" can represent a box full of deadly bees. See p. 22.

The Strangler Ape Class A

Find the biggest stuffed monkey that you can. Put it in your target's closet – preferably in a menacing pose. When the victim opens the closet, the killer ape is released . . . and guess who its first victim is?

The "generic giant killer beast" could just as easily be a lion, tiger or inflatable dinosaur.

Unwitting Accomplices Class A

If your target has a friendly pet that leaves the house at night, you might be able to attach a radio-controlled "bomb" (see p. 30) to its collar. When the pet goes back inside, you trigger the bomb. Man's best friend, NOT. Note that unless the scenario is a futuristic one, a pet-carried bomb will not blow up much more than the pet itself. Unless you can find a way to make sure the owner is right there when it is triggered, you've wasted your effort.

The GM is free to rule that pets are "innocent bystanders" and forbid this tactic.

Slingshots

Ping-Pong Balls

Class A

Ping-pong balls make safe ammunition for an ordinary slingshot. Best used in a primitive scenario, or by a killer who delights in the peculiar. In a science-fiction scenario the ping-pong ball can be a mini-grenade, and the slingshot wielder can take out a whole roomful of people. *Nothing heavier than a ping-pong ball should be used in a slingshot.*

Petards

A “petard” is a medieval bomb . . . a keg of gunpowder with a fuse in it. This is a time bomb (see *Bombs*) and should be permitted in medieval scenarios. Neither neat nor elegant, but very effective unless found – cf. Guy Fawkes.

Falling

Staircase Tripper

Class A

Twist a very thin “rope” out of toilet paper and tie it across a stairway, near the top. If the victim breaks the rope with his ankles, it is assumed that a real rope would have sent him sprawling to his death.

Broken Balcony

Class A

This works only if your victim is in the habit of leaning on some particular railing, balcony or window. Don't do anything *real* to the balcony – but put tape or leave a note on each bar, indicating that it has been sawed almost through. You may want to have the GM okay your handiwork in advance. You also need to make sure that the victim is the first one to lean on the “weakened” area.

The lethality of this device depends on the height of the balcony. A two-story fall could leave someone unharmed; a fall of 100 feet or more is close to a sure kill.

Shallow Pit

Class B

A very shallow (2 or 3 inches) pit may be dug and camouflaged as well as possible. If the victim steps in it, he will find a note explaining that he has fallen 6 feet onto sharp spikes. Don't do this on somebody's lawn, please . . . This particular method is time-consuming and elaborate, but funny when it works.

Dropped Objects

Pillows

Class A

A pillow may be dropped from a second- or third-story window (*no higher!*). This represents a rock or half-ton safe which will crush the unfortunate victim. A huge mass of balloons taped together will achieve the same effect, and its slow descent is highly humorous.

No object heavier than a pillow should be dropped from ANY height.

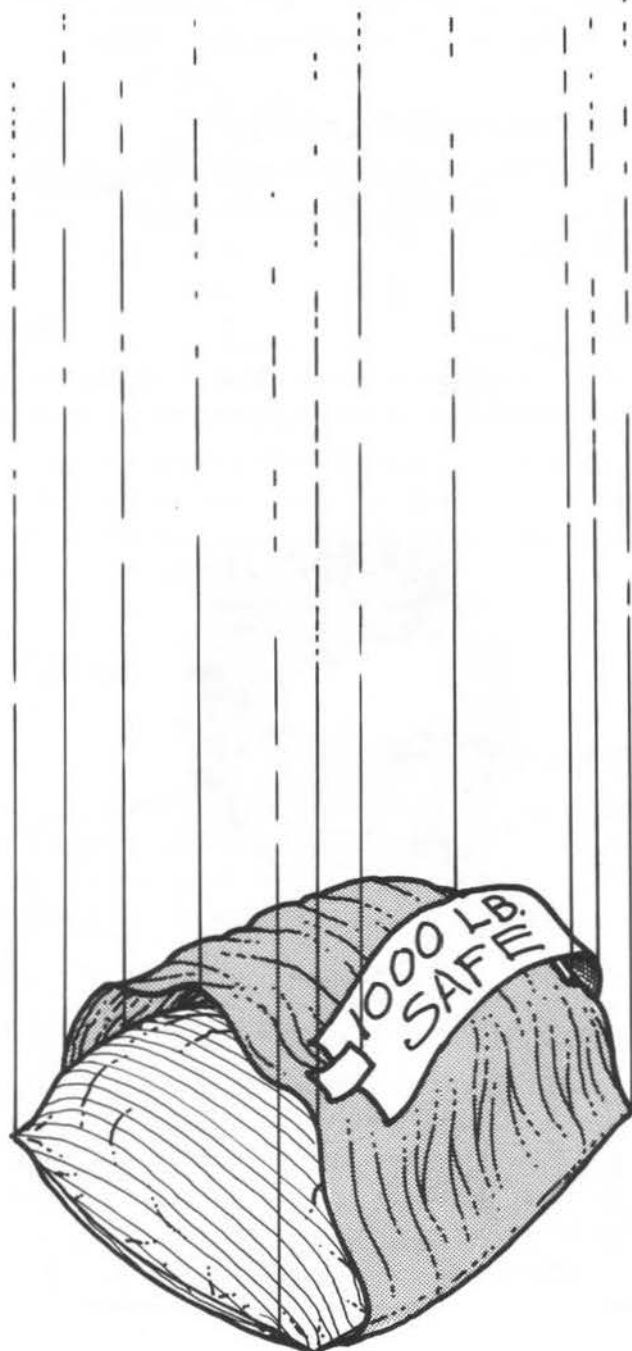

Confetti

Class A

A large amount (at least a double handful) of confetti may be dropped from a greater height to simulate that same half-ton safe. For safety, the confetti should not be confined in a bag. Of course, wind may cause it to spread, missing the victim. That's life.

In a medieval scenario, confetti may represent boiling oil. Outdoors, use birdseed instead.

Fire

Crepe Paper

Class A

If you can "wrap" a victim's house with orange

and yellow crepe paper, or any equivalent material, *without getting caught*, it may be assumed that you have successfully burned the house down, eliminating everyone who was inside it. If the would-be arsonists are caught in the attempt, the house does not burn. This method is not too effective against residents of dorms or apartments; the whole building must be wrapped in order to "burn," and even if some enterprising firebug manages to do this, he will almost certainly "kill" a number of bystanders as well.

If you don't want to burn down a whole building, you could try to catch your victim asleep and wrap his *bed* with crepe paper. Of course, if you catch him asleep, he's at your mercy anyway!

MODERN WEAPONS

Pistols

Water Guns

Class A

Any water gun makes a perfect assassin's weapon. Most water guns have a very short range and are noiseless – thus, they can be taken as "silenced pistols." A water gun is more suitable for a treacherous shot in the back than for any sort of "fair" gunplay. It has the advantage of (temporarily) marking its victims, eliminating arguments. A water gun may be loaded with dye, but this makes it a Class B weapon due to possible damage to clothes and property. Even "vanishing" dyes can stain clothes. If you wear old clothes, this doesn't matter.

Some water guns are painted to resemble the real thing. This is *not* a good idea. A fluorescent-orange gun will not alarm an off-duty policeman who sees you make a kill. A simulated Luger may cause problems . . . Stick with guns that *look* fake.

Novelty water guns in the shape of pens, cameras, etc., are available, and are especially good in a "spy" scenario.

Water guns have two severe disadvantages. First, they may leak while being carried in the pocket; this can lead to inconvenience, embarrassment, and possibly death if your victim realizes what you're carrying. Furthermore, a water gun does not always fire the first

time you pull the trigger. Several pulls may be required to "prime the pump," especially on a cheap gun. This delay can be fatal. Test any gun before you rely on it.

Window glass will not stop a bullet. Therefore, a water gun (or any other pistol simulator) can kill a victim on the other side of a closed window. Rules: The victim must be within 3 feet of the window, and must see you fire. Knock on the window – and when he turns, let him have it.

Cap Pistols

Class A

An ordinary cap gun makes a good assassin's weapon. Its disadvantages are that it is noisy and does not actually throw any sort of projectile. If cap guns are allowed, then any shot fired from 3 feet or less should be an automatic kill IF the cap fires. Otherwise, it is a misfire, and the killer has revealed himself uselessly. One-shot cap pistols are more sporting than the ones that fire a roll of caps.

Clicker Guns

Class A

These are toy guns that do nothing at all except make a clicking noise. Good only for short-range attacks, since they throw no projectile. Any clicker-gun attack at a range of 3 feet or less is automatically a kill. Otherwise, it's a miss.

Bananas

Class A

A banana is the ultimate non-violent weapon. To attack with a banana, you must get within 3 feet of your victim, draw your banana, and shout “Bang!” Simultaneous attacks are double kills.

A banana attack requires no marksmanship. However, a certain amount of skill is required, since a banana is hard to conceal and not truly suitable for a quick-draw attack. If the banana is crushed while in the assassin’s pocket, it cannot be used, though it may still be eaten.

The banana is also the safest pistol from the assassin’s point of view. Bystanders are not likely to intervene when one person chases another down the street brandishing a banana. Indeed, they may not believe they saw it.

Flag Guns

Class A

These comedy props are hard to find, but worth it. When the trigger is pulled, a flag pops out with the word BANG on it. Make sure the gun doesn’t look realistic. You should be within 3 feet to score a kill with a flag gun.

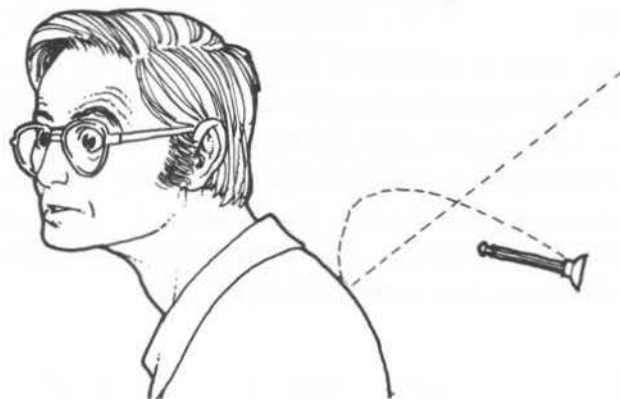

One very cute variation on the dart gun is sometimes found in toy stores as the “Spider-Man Web Shooter.” It is basically a one-shot dart gun that attaches to your wrist, inside your sleeve. When loaded, it is almost invisible except for the head of the dart in your palm.

The best dart guns, as far as safety goes, are those with *totally* soft darts. Look for them.

Again: *don’t* use real-looking guns. Stick with colored plastic.

Disc Guns

Class B

These toy pistols fire soft plastic discs about the size of a nickel. Most will hold at least 20, and fire as fast as you can pull the trigger. They are almost totally safe; some are more accurate than others, so be sure you practice first!

“Peashooter” Guns

Class B

These are toy guns that fire a small plastic disc or pellet, or a dried pea. All the same cautions apply to these as to dart guns. They are not as good for the game. They allow rapid but inaccurate fire, which can lead to argument. Many are so weak that you honestly can’t tell you’ve been hit through clothing, but some are so strong that they can sting. Furthermore, it is irritating to have dried peas all over the floor.

Ping-Pong Ball Guns

Class B

These devices use a spring or compressed air to shoot a ping-pong ball. Some are very weak and safe, but the author owns one, straight off the toy store shelf, that would raise a welt at 15 feet. Caution is advised.

Some PPB guns are single-shot – others allow rapid fire of five or more balls. Consumer alert: Some don’t work at all!

As for dart guns, above – don’t aim for the head.

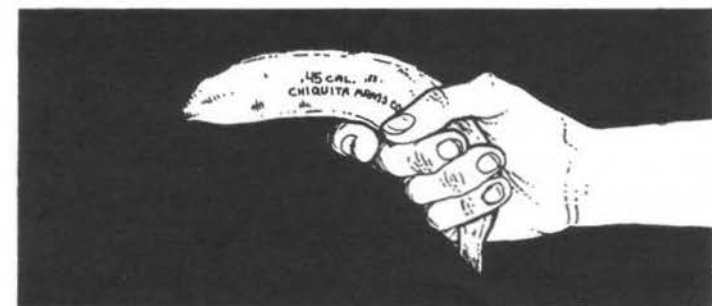

Dart Guns

Class B

A dart gun is *almost* safe. If the tips of all darts are fastened on with silicone glue, and head-shots are avoided, it’s a good weapon. GMs may limit each player to three darts, or allow an unlimited number. Dart guns have a much better range than water pistols, and the tips may be marked with chalk to show when a victim is hit. However, they make a SPRONG noise which can alert the victim if your first shot misses. Furthermore, they are slow to reload.

The exterior of a dart gun may be modified to hide its nature (and novelty dart guns that look like cameras, etc., are available). However, players should not be allowed to modify a dart gun to increase its strength without special OK from the GM.

Spud Guns

Class B

This is a toy gun which uses compressed air to fire a pellet of raw potato. The user carries a potato around and jams the gun-barrel into it at need, punching out a core which can then be fired. You'd have to hit someone in the eye to hurt them with a spud gun. Some of these shoot as far as 50 feet, but the pellet might not be noticed at that range. Note that if spud guns are in use, anyone seen carrying a potato is "displaying a weapon."

Rubber Bands

Class B

The world is divided into two kinds of people: those who can shoot a rubber band without hitting their own thumb, and those who can't. Members of the first group will find a rubber band a good weapon over short (3 to 15 feet) ranges. Avoid head shots.

Rubber Band Guns

Class B

If you can't shoot straight with a rubber band, there's still hope. The traditional wooden rubber band gun can save the day; it's harder to hide but easier to shoot. Use all the same precautions that you would when firing a rubber band by hand; in particular, avoid head shots. At the right are two kinds of rubber band guns you can build yourself.

More elaborate rubber-band guns are available, including repeating pistols and even tripod-mounted rubber-band machine-guns. Now we're talking real money.

Super Rubber Band Guns

Class B

These are expensive, high-tech toys which fire a special heavy-duty rubber band made out of a material like surgical rubber tubing. They are to regular rubber band guns as a Ferrari is to a Yugo.

They're still Class B – but just barely. They can deliver a *serious* ouch if fired at close range. But they're beautiful and amazingly accurate.

Paint Guns

Class C

Various sorts of marker guns, which fire a marble-sized ball containing paint, are used in the "National Survival Game" (see p. 58) and other paint-gun battles. In that context – wilderness games where all players have goggles and protective clothing – they are fairly safe. In a normal *Killer* game, where players are unprotected and the scenery is not likely to be

Lambard's Amazing Rubber-Powered Arms
Company Presents:

Rubber Band Guns for Fun and Profit

Anyone with some lumber and simple wood-working knowledge can create some spiffy-looking rubber band guns. Just follow the instructions below and start shooting! (Youngsters should have an adult aid them in using tools, and everyone should remember to wear protective gear.)

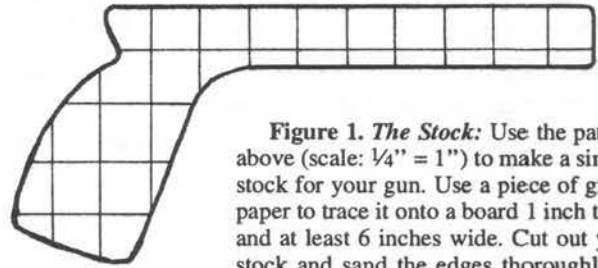

Figure 1. *The Stock*: Use the pattern above (scale: $\frac{1}{4}'' = 1''$) to make a simple stock for your gun. Use a piece of graph paper to trace it onto a board 1 inch thick and at least 6 inches wide. Cut out your stock and sand the edges thoroughly. If you wish, you can add a few coats of paint or varnish.

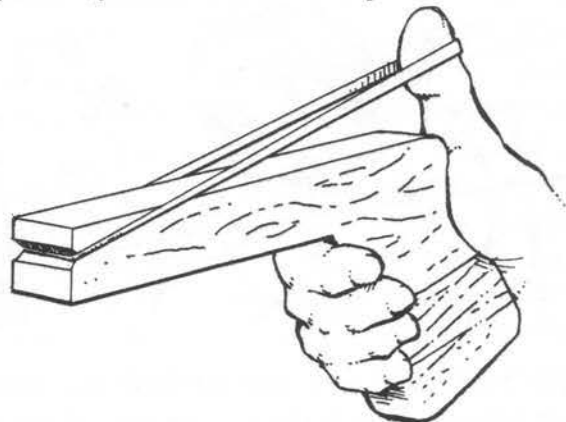

Figure 2. *Basic Model*: If you can't wait to start shooting, just cut a notch in the stock where indicated and you're ready to go. Hold the loaded gun as shown, and drop your thumb to fire. This can be hard on the thumb.

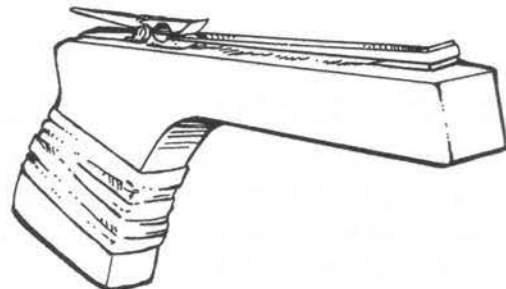

Figure 3. *Deluxe Edition*: This one takes a little more time. First, glue a small wedge of wood to the front of the barrel as shown. Next, glue a wooden clothes pin to the other end of the stock. Ordinary, white household glue is best for this purpose. Allow to dry 24 hours before using. Load the gun as shown and press the clothes pin "trigger" when you want to fire. Your thumb will never get tired. Note the extra ammo wrapped around the handle of the stock.

improved by random splashes of paint, this type of weapon should not be used.

Rifles

Cameras

Class A

In a game where the camera is a legal weapon, a kill is scored by showing the victim (or the GM) a photograph of the victim taken with a Polaroid, 35mm, or other camera. The victim (or a vital part of his anatomy) must appear in the center of the frame. Elegant ploys for a camera killer would be:

(a) arrange cross-hairs outside the camera lens to show you caught your target squarely;

(b) shoot your victim in front of a clock to verify time of death;

(c) post death-photos in a public place along with the name of the killer (optional), date, and time.



Camera buffs will note that professional attachments that automatically perform functions (a) and (b) are available commercially.

A camera can be used at short range, but it is much more fun to locate a telescoping lens and tripod in order to score a kill from a hundred yards away. Safer, too.

High-Pressure Water Guns

Class A

Many dart guns and water guns *look* like rifles, but have no more range than ordinary pistol-type weapons. However, some water guns are made with an auxiliary reservoir, allowing longer-range shots with fair accuracy. Excellent offensive weapons if you can find them, though a pistol is still better for defense.

Toy Bazookas

Class B

Some of these gadgets, which shoot a hollow plastic shell 10 yards or so, are still available. Use one like a long-range dart gun, with all the same precautions.

Air Cannons

Class C

These devices have no ammunition – they just shoot a big glob of compressed air, enough to ruffle your hair across the room. The trouble is that they are extremely noisy when they fire – enough so that they're not recommended unless the user wears ear-plugs. And a harder-to-conceal weapon is hard to imagine.

B-B or Pellet Guns

Class D

Using one of these on a human being is not only stupid – legally, it's assault and battery. Don't do it. The victim of such an attack could lose an eye, or worse.

Machine Guns

Water-Weenies

Class B

These gadgets are made by clamping or tying one end of a length of surgical tubing, and filling it up with water. It may be necessary to improvise a special nozzle. Once full, its end is pinched closed until the victim comes in sight.

Like a true machine gun, this device will cover a wide area in one long burst or a series of shots. It has a range of better than 20 feet, and is almost impossible to hide. Its only danger is to property which may be drenched by the spray.

Garden Hoses

Class B

Like the above, but more so. If your victim (or assassin) is foolish enough to come into hose range, you've got him.

Grenades

If you are using "wounding" rules, any *hit* with a grenade is an automatic kill. A miss that splashes its target with water, flour, confetti, etc., has a chance of only wounding, as per the Weapon Table.

Confetti Bag

Class A

This creates a mess, but nothing that can't be cleaned up harmlessly. The thinner the bag and the finer the confetti, the likelier it is to explode when it strikes the victim. If he gets confetti on him, he's dead. This weapon may be safely thrown from a second-



story window (higher is not a good idea). Aim for the sidewalk rather than the victim – a good burst will get him anyway. This is also a great weapon for taking out a group of people in a scenario where that is necessary. Scattering a handful of confetti is *not* legal – you have to throw the bag to simulate a grenade.

Confetti Eggshells

Class A

As above, but harder to make and easier to throw.



Birdseed

Class A

Use this outdoors instead of confetti. The mess will vanish overnight, and the birds will thank you for it.

Foam Peanuts

Class A

In some circumstances, foam “peanut” packing material is easier to clean up than confetti. But sometimes it’s *harder* to deal with. Think before you dump. (If the foam is one of the new photo-degradable or water-soluble varieties, then no mess will be permanent.)

Flour Bag

Class B

Just as above, except that flour (or powder chalk) may be used. This is an even better marker, but can be hard to clean up. Furthermore, a face-full of flour or chalk can be irritating and even painful. Use with discretion, and in **SMALL** bags only.

Water Balloons

Class B

An old favorite, fairly harmless if you’re outside. Balloons may be filled with dye (see *Water Guns*) using the same precautions – and outside *only*. If the victim is splashed, he’s dead. If a balloon (or other grenade) fails to explode, it may be thrown back.

If a balloon is filled half-full with shaving cream, and then inflated with water and shaken, the resulting “foam bomb” will produce a very effective explosion. It is somewhat lighter than a regular water balloon and less likely to go off when it hits, but more spectacular.

Glitter

Class C

Can be used like chalk or flour, and is very showy. However, glitter particles are hard and abrasive, and can cause *severe* irritation if they get in your eyes. Confetti is better.

Fireworks

Class D

Use of any sort of fireworks in this game is totally against the rules. They are illegal in most cities, and highly dangerous to victim and assassin alike.

Flamethrowers

Water-Pump Fire Extinguisher

Class B

Big, bulky, and inconvenient – but with a good long-range spray, this is a fair simulation. No real need

for it unless you're in a game that gives points for creative or horrible murders. Not dangerous to people, but can damage property if used indoors. Other fire extinguishers are *not* a good idea. A CO₂ extinguisher would be Class C at least – unpleasant to be hit with – and a chemical extinguisher should *not* be used under any circumstances.

Rocket Launchers/ Grenade Throwers

Any large long-distance weapon is going to be somewhat risky. Don't invent or use anything like this unless you're away from all bystanders.

Water Balloon Slingshot **Class C**

A traditional college weapon, this super-sling can lob a small water balloon for a long distance. Treat the balloon normally when it hits. Avoid high trajectories – this is just as dangerous as dropping the balloon from a great height! A somewhat hazardous device, of very limited use.

Water-Powered Rocket **Class D**

Don't use these. Though sold as a toy, they're no joke when they hit; they can break windows or leave bruises, and they are made of plastic that shatters into sharp fragments.

Electrocution

Rope **Class A**

A length of rope is taped to the wall *beside* the wall-socket, leading to a metal chair, bookcase, or other object. If the victim touches the object before removing the rope, he has been fried. Disadvantage: There is no way to be sure this device actually claimed its victim, or when, unless the GM or a neutral witness observes the rope still in place and the victim has obviously touched the booby-trapped object.

Real Electricity of any kind **Class D**

This falls into the category of homicidal mania rather than games. Any use of live wall current is potentially fatal to everybody involved. Even low voltages can be very dangerous. *Don't!*

BOMBS

In a duel of wits, bombs are perhaps the most elegant and satisfying way to send your target to his reward. The scope for cleverness, creativity, and downright fiendishness afforded to the bomber is unmatched by any other method of execution.

With a few exceptions (given under the specific listings) any bomb simulator *must* be a device that actually produces an explosion, identifiable loud noise, or obvious visual effect. You may not, for instance, place a slip of paper saying "BOOM" underneath a victim's pillow in order to blow his head off. The effectiveness of a bomb in this game is balanced by the fact that the assassin must actually build some sort of triggering device and use it to activate a noisemaker. A bomber must be clever!

If the victim of a bomb does not actually hear the bomb go off, he isn't dead. Again, victims are on their honor to die if they hear the explosion . . . but a bomb that you can't even hear is clearly a dud.



Bombs come in all sizes. The effectiveness of a bomb depends on its size. This is perfectly fair – the bigger the bomb is, the harder it will be to hide. An alarm clock by itself would be a small bomb. Put it in a shoe box, and it's a bigger one. Put it in a packing crate and, if not found, it can level a building. Any bomb that is not immediately obvious should have a note saying "BOMB" taped to the outside – though the *entire* bomb may then be hidden or disguised. This gives the victim a chance to find it if he is sufficiently paranoid.

The more modern the scenario being used, the more effective a bomb will be at any given size.

Guidelines:

Ancient bombs: A bomb must be at least 8 cubic feet in volume. This represents a keg of gunpowder. One keg will take out a room. Three kegs will take out a building.

Modern bombs: A letter-sized bomb will only get the person who opens it. A cube 3 inches on a side, or equivalent, will get one victim if it goes off near him. A cube 6 inches on a side will clear out a room. A cube two feet on a side (8 cubic feet) will level a building.

Futuristic bombs: A ping-pong ball will empty a room. A cube 3 inches on a side will level a building. A cube 1 foot on a side will eliminate a whole city.

Anyone killed by a bomb is within his rights to telephone a teammate who lives nearby and say "You just heard a big explosion out in this direction." Bombs are effective, but not subtle.

Bombs may be divided into four major types: time bombs, booby-traps, auto bombs, and remote-control bombs.

Time Bombs

Any device with a timer and an obvious "explosion" may be a time bomb – its effectiveness depends on its size.

Alarm Clock

Class A

The most elegant (and simplest) time bomb. Comes with built-in timer AND explosion – especially if it has a good loud ring. Size of the box it's hidden in determines its potency. You may use either a wind-up or an electric clock. The wind-up may give itself away by its ticking, but there's no telltale cord.

A miniature electronic alarm clock makes a great bomb; although its beep may not be as dramatic as a loud explosion, it's good enough. Some are as small as credit cards, making them modern "letter-bombs" or futuristic room-sized bombs. Of course, a small clock may be housed in a big box for greater effect.

Best of all, some electric alarm clocks have their own power socket, so they can turn on another item when they go off.

Book Bomb

Class A

A large hollowed-out book makes an excellent disguise for a small bomb simulator – an alarm clock, for instance. Depending on the victim, a book may stand out in his house like a sore thumb . . . or it may blend in perfectly. A book may also be booby-trapped to explode when opened – see the section on booby-traps.

Kitchen Timer

Class A

A variation on the clock idea. A plain old timer, with its jarring ring, is a great time bomb. The only drawback is that most kitchen timers can't be set for any period longer than an hour.

Electric Timer

Harder to hide, but more versatile. The timer is set to turn something on at an appropriate time – preferably something noisy or noticeable, like a siren, lamp, or blender. Either the timer or the object to be turned on must have a "BOMB" notice on it, to give the victim a chance to find it. This idea may be used with a tape recorder (below).

Tape Recorder

Class A

The recording on the machine consists of blank tape – up to the time when the explosion is desired. Then you get the BOOM – perhaps followed by a consoling remark from the assassin. A fiendish variation on this is the Robert A. Heinlein Thirty-Second Bomb. Instead of exploding, the recorder suddenly announces "I'm a thirty-second bomb! I'm a thirty-second bomb! Twenty-nine . . . twenty-eight . . . twenty-seven . . ." This one may not kill your victim (unless his door is locked from the outside) but it will turn his hair white. Of course, you can also do the Lying Thirty-Second Bomb. It says "I'm a thirty-second bomb! Twenty-nine . . . twenty-eight . . . BOOM. I lied."

The Foucault Pendulum Timer

The first edition of *Killer* contained a challenge: to find the bit of “misapplied physics” that would allow a balloon-bomb to be set off using the earth’s rotation as a timer – and *without* depending upon the sun!

Our ingenious readers solved the puzzle in short order. The explanation, as originally presented in *Space Gamer* 45:

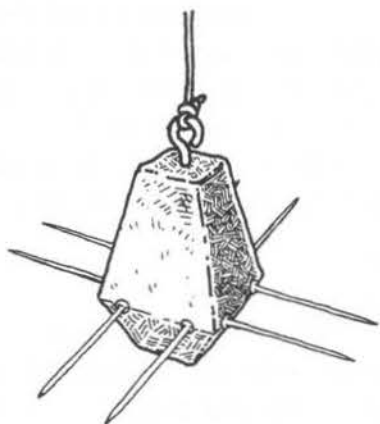

The Foucault pendulum was demonstrated in 1851 by Jean Bernard Leon Foucault, the brilliant French physicist who also invented the gyroscope. Basically, it consists of a long pendulum, freely suspended and bearing a weight heavy enough that it will not be affected by air currents. Such a pendulum, like all pendulums, will swing in a straight line once released. However, the earth continues to rotate *under* the pendulum; thus, when the pendulum has swung for six hours it will appear to have moved 90 degrees in its arc, tracing a north-south line where it originally moved from east to west. See the illustrations below.

To adapt the pendulum for *Killer*, it would be necessary to attach several sharp points to the swinging weight (one point will be insufficient, as the weight will spin as it swings). A balloon is then placed at some point along the arc the weight will describe, and the weight set swinging: 45 degrees off for a 3-hour delay, 90 degrees for a 6-hour delay, etc.

Properly made, this device is almost foolproof, since it depends on an extremely basic fact of nature. However, its disadvantages are many; for this reason, we will be extremely interested to hear about any successful use! The problems to overcome are:

(1) A more obtrusive sort of gadget cannot be imagined. It cannot be hidden, since it is very large; it cannot be disguised easily. One possible way to overcome this would be to “hide it in plain sight,” labeling it as a science demonstration of some sort – in which case you would, figuratively speaking, endanger bystanders.

(2) Once recognized, it is trivial to defuse.

(3) Because such a device would take a long time to set up and test, a certain inaccuracy in timing would have to be accepted; to have one detonate within 5 minutes either way of the target time would be very good indeed.

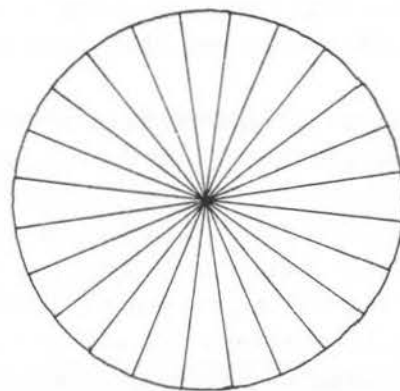

If the center of the wheel above represents the place where the pendulum will hang at rest, the border of the wheel shows the limits of its swing. The target balloon should be placed on this rim. The twelve lines show the hourly movement of the pendulum, as do the arrows below – from N-S to E-W in six hours.



Addendum: We are indebted to Pierre Savoie for pointing out that the pendulum will actually have a 24-hour period only at the North or South Pole, where very few simulated murders take place. On the equator, it swings in the same line indefinitely! At 45 degrees latitude, the period is 33 hours and 56 minutes; at 30 degrees, 48 hours. The actual formula is 24 hours divided by the sine of the pendulum’s latitude.

If your victim keeps notes to himself on a pocket tape recorder, you can add insult to injury by leaving your message on his own gadget.

Archimedes' Timer

Class A

A can or bucket filled with water hangs from a heavy piece of elastic. A hole in the bottom of the can allows the water to escape, a drop at a time, into another can or bucket below. As the first can empties, it becomes lighter, and the elastic shortens. Thus, the can is pulled higher. When it rises high enough, a pin glued to the top of the can touches a balloon . . .

Solar Balloon Bomb

Class A

Use a dark-colored balloon. Place it in a window, where the heat of the sun will expand it and bring it in contact with a strategically-located pin . . .

Fused Balloon

Class C

This is suitable ONLY for use in an area where there is NO danger of fire. A slow-fuse is prepared and attached to a balloon (a cigarette is a good 5-minute fuse). When the fuse burns down, the balloon blows up.

Booby-Traps

The construction of infernal devices to be triggered by the victim himself is an ancient and semi-honorable pastime. The methods below only scratch the surface. Readers are encouraged to come up with their own ways of killing their friends without hurting them.

Button Letter-Bomb

Class A

A device (see illustration) is constructed as follows: Take a bobby-pin and spread the prongs. A large button or piece of heavy cardboard is threaded on a rubber band, the ends of which are then tied to the prongs of the bobby-pin. The button is turned around and around to wind up the rubber band; the entire assembly is then sealed in an envelope. When the envelope is opened, the released tension will cause the button to rattle against the walls of the envelope.

Unless you are playing a future game (or the GM decrees it is more powerful) this tiny device would kill only the person who opened the envelope. However, a

larger and noisier version could be created, which would fit inside something the size of, say, a wargame box.

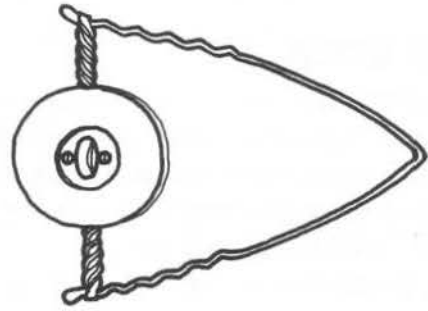

Tack and Balloon

Class A

This technique is adaptable to hundreds of situations. A tack is fastened in such a way that the victim will press a balloon onto it. Doors, windows, car seats, drawers, *ad infinitum*, can be prepared in this way. An average-sized balloon represents a bomb big enough to eliminate the victim.

Alarm Clock

Class A

If a mechanical alarm clock is set so that the hands do not move but the alarm is fully wound up, it will go off whenever the "alarm" knob is pulled. A string may then be tied to that knob, with the other string tied where the assassin feels it will do the most good . . . doorknob, on a book on the desk, or what-have-you.

Push-Button Trigger

Class A

Any noisy or alarming device (the author did this with a strobe light and the effect was fantastic) that is triggered by a push-button can be made into a booby-trap. A weight is propped over the push-button, or a rubber band set to press a makeshift lever against the button when a prop is removed. A string or other trap is then set. When the victim pulls the string, he will be strobed, sired, serenaded, or otherwise assaulted by your "bomb."

Typewriter Bomb

Class A

This will not work with daisy-wheel or ball-type typewriters, but if your victim has an old-style typewriter with arms that come up to strike the paper, you can get him. Tape your "BOMB" note to one of the

arms . . . say, “G” for “gotcha.” When that key is struck, the note will keep the G from printing – and when the victim opens the typewriter to see what is wrong, he’ll find the note.

Computer Bomb **Class A**

This requires that both you and your victim have access to a computer or other printout device. The assassin must access the victim’s program or other routine and arrange that the first printout the victim gets will be “YOU ARE DEAD . . .”

It is an awful thing to be betrayed by one’s own computer.

Flashlight Bomb **Class A**

This trigger-mechanism can be used to set off a buzzer and/or light, preferably attached to a box on which the note points out that “If this light is on, you are dead.” The device is historically accurate; in WWII it was used for genuine booby-traps that claimed hundreds of lives. A string or other pull-type trigger jerks a piece of cardboard from between the jaws of a wooden clothes pin, allowing two wires attached to the clothes pin to come together and complete a circuit. One or two flashlight batteries will provide all the power needed for a small buzzer.

Light-Switch Bomb **Class A**

The assassin replaces a light-bulb in the victim’s room with a screw-in socket. A buzzer, siren, flasher, or other electrical noisemaker is then plugged into the new socket. When the victim turns on the light-switch, the device will be activated. This is a very sporting sort of bomb; the victim will always see it if he bothers to look before he turns on the switch, but most people are creatures of habit and will flip that switch without looking . . .

An even easier murder method is to replace the victim’s light bulb(s) with red ones, adding a “BOMB” note taped to the outside of the lamp or light fixture. If he is incautious enough to flip the light-switch without looking at the light – boom! A slightly sneakier variation is to find an electrical outlet that is controlled by a wall switch, bring in a new lamp, place it in a corner, and plug it into that outlet. Bathrooms, in particular, often have switch-controlled outlets just sitting around waiting to be used.

Dummy Time Bomb **Class A**

A large box marked BOMB, with a cord leading to a wall-socket. The cord actually belongs to a harmless device inside the box. The actual triggering mechanism is designed to set off a tack-and-balloon system when the box is opened or disturbed. The victim will gloatingly unplug the device, open it . . . and BOOM.

Reverse Trigger **Class A**

The basic idea is to leave a trigger-string where your victim will be sure to see it. If he cuts the string in hopes of disabling the bomb – it goes off. One way to accomplish this is shown below. There are many others . . .

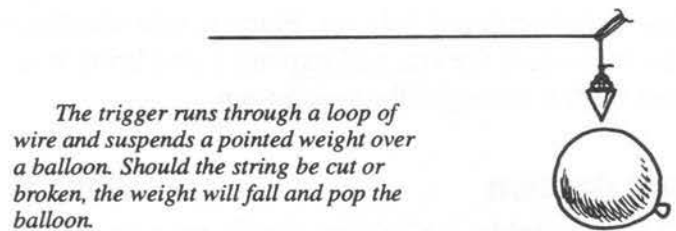

False Bomb **Class A**

A large box marked BOMB. It lies. It is not a bomb at all, but it will give your victim fits. A clever strategist can use a dummy bomb in order to get his victim to come into the open, call his Godfather, or make other hasty and dangerous moves.

Whoopee Cushion **Class A**

Place this ancient and loathsome gag underneath a seat cushion, as per custom. If your victim sits on it and it performs properly, you may assume that he has been blown to Kingdom Come by a small pressure mine in the chair.

“Time Bomb” Toy **Class A**

An actual toy in the form of a spherical black bomb, complete with red plastic “fuse,” timer, and sound effect, can be found in some toy stores. This would represent enough explosive force to empty a room, and is certainly the best sort of bomb for the traditional-minded or “camp” killer.

Bubble Packing Material **Class A**

The plastic packing material composed of two sheets of plastic, laminated together with air-bubbles in between, makes a good land mine. If stepped on by

an incautious intruder, one or more of the plastic bubbles will explode with a sharp pop. This is an excellent defensive weapon. A victim may also designate this material as nothing other than itself . . . using it, not as a mine, but as a simple and cheap warning device that does not have to be purchased with game money.

Magnetic-Reed Bomb **Class A**

This one requires a bit of knowledge, but it's not hard to implement. Set up a normally-open magnetic reed switch, attached to a light or buzzer. The activating magnet should be on something the victim is likely to reach for – desk or telephone, for example. When the magnet is moved, the switch will close and the “bomb” will go off.

Candle Bomb **Class A**

Anybody who accepts a gift of a giant-sized candle while playing *Killer* – or even lights an old one – deserves what he gets. Nevertheless, this sometimes works. Simply tape a note saying “BOMB” to the bottom of a good-sized candle in your victim's room. The victim is literally lighting the fuse when he lights the candle! The bomb goes off instantly, doing damage appropriate to its size.

Wax-Fused Bell **Class A**

A push-button bell – the type you see accompanied by a “Please Ring For Service” placard in stores – is placed on a window sill or beneath a hot-air register. Above the bell is a ball-bearing, held in place by a piece of soft wax. When the sun comes up the next morning – or the heat is turned on – or whatever – the wax melts, the bell rings, and the bomb goes off. As always, a “BOMB” note should be attached to the gadget.

Smoke Detector **Class A**

A small commercial smoke detector can be used as a bomb in two ways. First, you may simply arrange a mechanical linkage to trigger its alarm when (for instance) something is moved. The shrill sound will not only tell your victim that he's dead, but (in all probability) send him right up the wall. It would only be common courtesy to attach a note to the “bomb,” explaining how to turn it off.

Much more elegant is the use of a smoke detector to terminate a smoker. Simply place the device above

his desk – right over an ashtray is best – and wait. Obviously, some attempt at concealment is a good idea. If all goes well, the smoker will provide the smoke, the detector will perform its intended function, and you will have gotten your man. If this helps him give up smoking, so much the better . . .

Sound Sensors **Class A**

Commercial sound sensors are now available relatively cheaply. Just hook it up to a loud buzzer and put it where (you hope) your victim will be the first one to make a loud noise. Calibrate first to make sure a dog barking next door won't set it off! To be legal for *Killer*, this should be set so the buzzer can't be turned off except by unplugging it. That way, if the bomb goes off early, it can't just reset itself. Real bombs don't do that.

Motion Sensors **Class A**

These are standard burglar-alarm components. They can easily be adapted to set off a “bomb” when the victim enters their range. Like sound sensors, they might go off accidentally if not tested carefully, so the buzzer or other bomb simulator has to be non-resetting.

Video Bomb **Class A**

Make a custom videotape with whatever bomb sound and picture effects you can achieve (spliced-together clips from old disaster movies are good for this). When your victim plays it, he's history.

Vacuum Cleaner **Class A**

What could be more innocent than a vacuum cleaner? What could be more fiendish than to turn someone's faithful Electrolux into an instrument of doom? Easily done. Just take a handful of confetti and insert it into the exhaust. When the vacuum is turned on, the confetti will go absolutely everywhere. Fortunately, your victim is in a good position to clean it up . . .

Short Sheets **Class A**

That old camping-out standby, the short-sheeted bed, can represent a deathtrap. And it adds insult to injury to get someone with a trick this old.

For those few who have never done this . . . Remove one sheet from the bed. Fold the other double, so it doesn't reach the bottom of the bed – both ends are

at the top. Thus, it *looks* like the bed has two sheets, but when the victim tries to get in, he gets tangled up in the single sheet. Add a note between the sheets, which the victim will find after he's "dead."

Snake in the Glass

Class A

An even more ancient gag is the spring-loaded "snake" that pops out of a fake can of nuts. This is most likely to work if removed from that suspicious-looking nut can and placed in (for instance) a hollowed-out book. It can represent either a small bomb or a real snake! Just make sure it doesn't *look* real if your victim is terrified of snakes.



Powder Bomb

Class B

This nasty device can be used for booby-trapping a door. It is built as follows:

(1) Take a single layer of tissue paper. Fill the center with flour or confetti, fold it into a rectangle, and tape it shut.

(2) Place a rectangle of tape on the bottom of the powder packet, leaving about a half-inch around each edge.

(3) Tape one end of a thread to this inside rectangle.

(4) Tape the packet to the doorjamb over the door, with the tape-rectangle side down and the end with the thread attached *away* from the doorknob.

(5) Run the thread through a screw eye in the corner of the jamb above the knob. Fasten the free end of the thread to the doorknob; leave about a foot of slack. This will allow you to leave through the door (carefully), and make it likelier that your victim will be in position when the packet bursts.

When the door is opened, the thread will pull on the tape rectangle and rip it loose from the rest of the packet, dumping the contents on your victim. For best results, use inconspicuously-colored thread and tape. Tape all connections securely. A decoy trap (such as contact poison on the doorknob) will distract your victim's attention at the critical moment.

Flashcube

Class B

For those who are tired of the BANG and want to simulate the FLASH instead, there are any number of ways to trigger an ordinary flashcube as a booby-trap. The easiest, of course, is simply to use a camera – but there are lots of others. Be creative.

Plug-In Trojan Horse

Class B

Making this device requires simple electrical wiring. Don't do this unless you are competent to rewire a lamp properly, and unless you're willing to replace the gimmicked device if you make a mistake.

Most electrical devices have a lot of empty space inside the shell. A "bomb" – a bell or buzzer – can be placed *within* the casing of a radio or similar device and wired into (or, safer, instead of) the main power circuit. When the radio is plugged in – BOOM.

Mousetraps

Class C

It is child's play to arrange a mousetrap so that the victim will joggle it and set it off. The challenge lies in making sure that no fingers will be mashed. Putting the trap into a box is a good solution – this also gives a larger (and more effective) bomb. Large rat-traps should *never* be used.

Snap-Caps

Class C

These are tiny devices consisting of a small amount of contact explosive in a twist of paper. They explode

when stepped on or dropped. As such, they may be used as “land mines,” placed under a board. It is best to use these outside if they are used at all, and to follow all cautions on the package. Though sold as a children’s novelty item, they are not totally without hazard. Never use them in areas where people are likely to walk about barefoot.

Exploding Cigar

Class C

Even if you can find someone who still smokes cigars, and who is foolish enough to accept an unfamiliar brand while playing a game of *Killer*, the trick isn’t necessarily as harmless as the novelty-shop catalogues would have you believe. But if you offer someone a cigar during the game, they may *think* they know what you’re up to, and be less alert to the real attack.

Auto Bombs

Automobile Bomb

Class A

This simulates the “bomb under the hood” that explodes when the car’s engine is turned on, and does so in a truly fiendish manner. All the killer needs to do is get into the car and turn the radio (or whatever) up as loud as possible. When the victim turns his ignition key, he will be blasted . . . by sound! And the car is NOT yet moving, so it’s safe. This ploy is exceptionally effective if the victim’s car has a tape deck that can be primed with the *1812 Overture*.

Sometimes a victim may not realize that he has just been blown up by his radio. It is therefore a good idea to leave him a note, in the car or elsewhere, to make sure he knows that he’s dead.

Whistle Exhaust

Class A

A cheap plastic whistle is taped onto the exhaust of the victim’s car in such a way that the exhaust will blow the whistle. (Experiment on your own car first.) A note explaining that the whistle is a bomb should be attached; if the attack is to be more than a nuisance, a box to represent the actual bomb must be added. This is reasonably safe, as the car is not in motion when the whistle sounds. DO NOT use the “exhaust pipe pranks” sold in the backs of comic books. Some of these are firework devices which can ruin a vehicle’s exhaust.

Balloon Under the Hood

Class B

A large balloon can be wedged into the fan-belt under a car’s hood to represent the archetypal gangland car-bomb. Exercise caution when doing anything to a car’s motor. Don’t fool with the wiring at all – this can cause expensive repairs or even accidents. Warning: If the car has a noisy motor, the victim may not hear the balloon when it explodes.

Note Under the Hood

Class B

This is not a very classy technique – it does not explode. However, it is a relatively safe way to “trap” a car. To do this, lift the car’s hood and tape the note in plain sight on the air-cleaner, where it is visible and can’t get in the way. If the victim checks his hood, he’ll find it. If he never checks, you can tell him to look under the hood – *after* he uses the car. The problem is that this method produces no explosion – therefore requiring no cleverness on the assassin’s part – and the victim may not know that he is dead for some time. If the GM is allowing “note” bombs, the places they may be put *must* be rigorously specified to keep the technique from being abused. After all, a note is much easier to hide than a real bomb! Any note must be immediately visible to anyone who bothers to look.

Remote-Control Bombs

A remote control bomb is one set off by the assassin – preferably from a distance – when the victim is preferably within range. Note that if the assassin is within the bomb’s range (determined by the size of the box) when it goes off, he is *also* dead.

Extension-Cord Bomb

Class A

A buzzer, siren, or other boxed “bomb” is hidden where the victim will come near it. It is plugged into an extension cord which leads to the hiding place of the assassin. At the opportune moment, the assassin plugs in the cord (or switches it on, if there’s a switch) and blows his victim away. Sometimes a spotter, or even a chain of spotters, will be needed to signal the bomber when to plug in his device.

Remote-Controlled Balloon

Class A

Identical in effect to the above, except that the “bomb” is a balloon, and the triggering mechanism is

a string which, when pulled by the assassin, jerks the balloon into a pin.

Radio-Controlled Device **Class A**

If you're capable of building an R/C signaler to remotely turn on a buzzer or flasher in your victim's room when he walks in . . . go to it. Such gadgets are expensive in terms of real money as well as game money – but they are the safest sort of remote-controlled device. Of course, if your victim finds it and knows who it's from, he may turn the tables on you by planting it in YOUR room before you trigger it . . .

Some very inexpensive remote-control-devices are now sold as “wireless doorbells.” Push the button on the remote unit, and the bell unit chimes. This makes simulated bomb-building almost *too* easy.

Walkie-Talkie Bomb **Class A**

This is the easiest radio-operated bomb . . . a radio! A “BOMB” box is hidden in the victim's room – or, if you want to add insult to injury, left in plain sight. A walkie-talkie, set to receive, is inside. When you feel your victim is within range, you can use the other walkie-talkie to provide a loud BOOM, adding any personal messages you feel appropriate.

Cellular Phone Bomb **Class A**

Exactly the same principle as above, with the added advantage that you can detonate it from anywhere in the world if you don't mind paying long-distance charges.

Telephone Bomb **Class A**

Acquire or borrow a cheap phone with a distinctive ring. Sneak into your target's house and plug it in –

either replacing his own phone, or (much sneakier) using a forgotten phone jack in another room. Put a “BOMB” note on the phone, or enclose it in a box. Either way, when you (or somebody) dials his number, the bomb goes off! This gadget is not legal in any scenario set before the invention of telephones . . .

Fused Fireworks **Class D**

Under no circumstances should ANY variety of fireworks (long, short, or medium fused) be used. Not only is this highly illegal in most cities . . . you can burn down a building or seriously injure your victim.

The Bomb Squad

A player who finds a bomb set to kill him may either try to defuse it himself, or “call the bomb squad.” Each tactic has its advantages.

If a player can defuse a bomb, he may keep it and use it himself (returning any surviving components to the GM after the game). This can be useful in a scenario where bombs cost a lot of game-money . . . or where the device was a complicated and fiendish one. Most bombs will be easy to defuse, but a clever assassin may rig one to go off if tampered with.

In some cases, therefore, a player may not want to do anything except leave the area as quickly as possible. This is reasonable; after all, a player will be killed if he tries to defuse a bomb and it goes off. A cautious player can “call the bomb squad” by contacting the GM and informing him that he has found a bomb. The GM will make note of the fact, and authorize the player to remove the bomb without danger. There are two problems, though:

(1) The player does *not* get to keep the bomb he found.

(2) The GM may rule, when contacted, that the player must stay out of the “danger area” for a half-hour to two hours, while the bomb is being removed. This can be a great inconvenience; it can also set the victim up for another assassination attempt!

If the GM cannot be contacted, the bomb squad is not available, and the player must do the best he can. Keep in mind that it is not legal to use an accomplice or bystander to set off a bomb.

The GM may give extra points for defusing a bomb, or take away points for chickening out and calling the bomb squad. This would be especially appropriate if everyone was roleplaying.

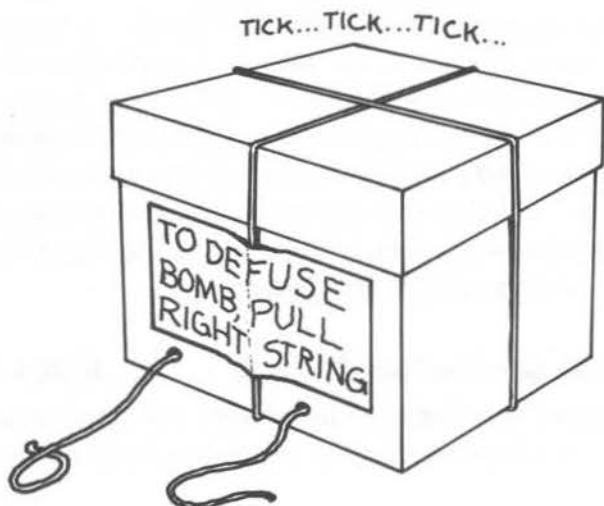

POISONS

Introduction of “poison” into the victim’s food or drink (or whatever) also offers great scope for cleverness. Again, the victim should always have a chance to detect the poison. Poisons are assumed to act quickly. Upon finding himself poisoned, the victim should clutch his throat, exclaim “aaarrgh,” and expire.

Poison Notes for Food

Class A

The word “POISON” is written on a piece of paper and taped to the bottom of a bowl or glass (or hidden in a dish of candies, etc.). If the victim eats or drinks before finding the note, he’s dead. The note can also be put on/in a victim’s aspirin bottle, contact lens solution, etc. Lipstick or grease pencil may be used to write directly on the bottom of a plate or bottle. It’s especially elegant to write the note on the bottom of a glass plate or mug, so the victim can easily see it *after* he’s started to eat.

Dry Ice

Class A

Any booby-trap or remote control device which dumps dry ice into water can be considered a poison gas generator, killing anyone in the room when it goes off.



Double-Sided Adhesive Tape

Class A

A strip of this tape can represent contact poison. It’s quite visible, so use it where the victim will reach without seeing – or at least without looking. Write “POISON” on or under the tape, just to make sure the victim doesn’t miss the point.

The Kiss of Death

Class A

An exceptionally friendly way to off someone. The killer coats his or her lips with a flavored lip balm and gives the victim a good smooch. To give the victim a decent chance, the “poison” should be visible if one

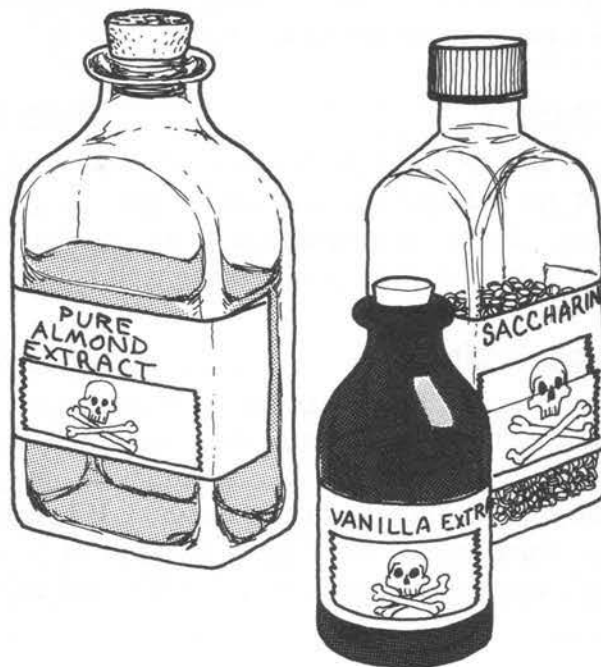

bothers to look. (Females may use ordinary lipstick if it is of some weird color.) The killer is assumed to be immune to the poison.

The Nails of Death

Class A

Anyone (male or female) may paint their nails an exceptionally garish color. Anyone touched by the painted nails is poisoned. The assassin himself is assumed to be immune.

Hard Candy

Class A

Small candies make excellent *edible* poison tokens. Use as you would any other poison indicator.

Chocolate Beer Killers

Class A

Chocolate with a hard-candy coating will (at first) do nothing if dropped into beer – but when the coating dissolves, the beer will begin to foam the color that the candy was. This is a highly distressing way to knock off a beer-drinker.

Seltzer Drop

Class A

A booby-trap rigged to drop seltzer tablets into a glass of water can represent a gas-generating device which will kill anyone in the room.

Poisoned Shower

Class A

This one is *evil*. Put several drops of tempera paint powder in the victim's shower head. If he or she turns on the water while under the shower, without looking – it's all over. DO NOT use anything except standard water-soluble tempera, which will wash off easily.

Hand Buzzer

Class A

If you can get away with this hoary jest, it can represent that beloved device of the Borgias, the poisoned ring. (If you can get your victim to shake hands with you in the first place, you're doing well.)

Envelope Toxin

Class A

If your victim habitually opens envelopes by tearing off one end and then blowing into them, send him a letter with a little flour or fine confetti inside, along with a note explaining the murder method. If he follows his usual pattern, he'll get a face-full of your "poison," and you can start planning for your next victim.

Beastly Books

Class A

A "POISON" note at the end of the book warns the reader that the pages were coated with a slow-acting contact toxin. One who read the book wearing gloves would be all right, of course, but that's unlikely. On the other hand, you have to touch almost every page to get a lethal dose, so looking at the last few pages for a note would be a safe way to check. Therefore, the clever killer will use a *mystery* book, in hopes that the victim would avoid looking at that last page!

Poisoned Weapons

Class A

There is no need to poison weapons unless you are using "wounding" rules. If you are, a knife or spear may be poisoned by putting a little ketchup or similar goop on the blade. If the victim is stabbed with a poisoned weapon, the GM will roll twice to check results. If the knife itself does not get him, the poison may.

Toilet Tank Trap

Class A

Place a large amount of food coloring (green is best) in the *tank* of your victim's toilet. When the toilet is flushed, the dye (representing a highly volatile poison) fills the bowl, killing the user. One possible drawback: if the dye leaks into the bowl over a period of time, it might tip off your intended victim.

Poisoned Candle

Class A

An authentic Renaissance method of assassination. Pin a "poison" note to the bottom of an ordinary candle. If the note is found before the candle is lit, no harm is done. If the candle is lit, though, the person who lit it is dead. And if it remains lit for more than five minutes, everyone in the room is dead, and so is anyone who enters the room while the candle is burning (unless they hold their breath). A variation: the "poison" is buried within the candle, represented by a mark on the outside of the candle . . . or, if you want to be really classy, by a blob of dark-colored wax buried within the candle. The poison does not become effective until the candle burns down to the appropriate point.

Poisoned Jewelry

Class A

Another good Renaissance killer. Give your victim a piece of jewelry which is, theoretically, treated with a very slow-acting contact poison. This is represented by the word "POISON" which you have thoughtfully had engraved right there on the item – in very small letters, of course! If the booby-trapped bauble is worn for more than an hour, the wearer is dead. Since the poison is slow and cumulative, the poisoner can handle the item (briefly) without danger.

Fake Food

Class A

Novelty shops offer a variety of plastic hot dogs, cheese slices, and so on. Some of these look very real indeed. Just make sure they're clean before you serve them to your soon-to-be-late friends.



Poisoned Picture

Class A

This is a contact-poison trick; it can be accomplished with a note, or with double-sided tape, or by other means. The basic method is the same, though. Pick a picture in a prominent place on the wall, turn it a bit crooked, and put contact poison on the sides, where the victim will touch it to straighten it. If your victim is an especially compulsive type, you can do this in *someone else's* house before he visits . . .

Deadly Chair

Class A

A sticker marked "POISON" is placed on the *back* of a chair where the victim is to sit – or, if the chair has a cushion, *under the cushion*. This represents a hypodermic device which will stab and poison him when he sits down.

Poisoned Video or Cassette Tape

Class A

Affix a tiny "POISON" note to the box. Switch the tape inside for one of your own, switching labels as well (not always easy, but it makes the kill much more artistic). When the victim plays the tape – having, presumably, touched the box in order to get it – he gets a personal message from you, telling him he's dead.

Poisoned Floppy Disk

Class A

As above, except the disk itself, or its disk sleeve, must be marked "POISON." Marking the *back* of the sleeve is fine. When the disk is placed in the computer, it boots up and delivers the fatal message you have thoughtfully placed there. Note that a computer disk can be used to represent murder methods other than poison – see p. 26.

Poison Tokens

Class B

These tokens should be large (at least the size of a quarter) and made of some solid, non-toxic substance. They should say "POISON" in large letters. Secrete one in your victim's food or drink. If he examines the poisoned repast, he will find the token. If he eats or drinks, he will find it anyway . . . too late. *The token must be made in such a fashion that it cannot really be swallowed!*

Salt or Flavoring

Class B

This is the most realistic method of poisoning food or drink. The problem is that it ruins the food. A large amount of salt or some other food flavoring is added to

the food. The victim will detect it if he takes a small bite or sip, and will not be harmed. If he takes a BIG bite, he's dead. Do not use *anything* except food flavorings; artificial sweetener is good for this, too.

Gas Balloon

Class B

Any tack-and-balloon device may bear a note saying "POISON GAS" instead of "BOMB." If it goes off, it will kill those in the room (only). The advantage of gas is that it is quiet. A little almond extract in a balloon will produce realistic cyanide odor – or perfume may be used instead. If no odor is used, this is a Class A device.

Aerosol Spray

Class B

A spray can of air freshener or other *harmless* material is rigged as a remote-control or booby-trap. There are many ways to do this – one is shown below. If the gas trap is triggered, everyone in the room is dead. Often the victim's first warning will be the strange scent in the room and the quiet hissing . . . *Never point an aerosol can directly in your victim's face.*

Select a rubber band that, when looped around the can, ALMOST (but not quite) triggers it. Tie a string to the rubber band. When the string is pulled, the can will fire, and the natural tension of the rubber band will keep it activated until it is empty.



Poison Gum

Class B

Novelty shops often sell "garlic gum," pepper candy and similar loathsome items. If you can induce your victim to chew a stick of this stuff, he's dead – as well he deserves to be.

Trick Soap

Class B

Another novelty-shop item is a fake sort of soap which causes the victim's hands to turn black when he or she washes. A good way to score a kill, if you can find it. If the victim doesn't notice that his regular bar of soap is missing . . . well, too bad.

Killer CDs

Class B

Using *washable* felt-tip markers, experiment on old CDs until you find a marker which dries slowly or not at all on CD plastic. Thus, the marker-coloring will

come off on the fingers of anyone who handles the CD. Holding your victim's CD by the hole in the middle, color the edges. This does not require a separate "POISON" note, because the poison itself is visible, and in plain sight.

Petroleum Jelly **Class B**

This slimy stuff can be used to represent contact poison (on the bottom of a doorknob, for instance). Disadvantages: You can't write on it (so if you want to leave a note, you'll have to do it somewhere else) – and it *can* stain some materials.

Pestilent Perfume **Class B**

Substitute something with an interesting odor – say, vinegar – for the victim's perfume or aftershave. Don't use anything that would cause injury or damage clothing!

Sneaky Snack **Class B**

This requires either sleight-of-hand or an accomplice – preferably a waiter or chef in the restaurant you and your victim are about to visit. Fast talk and a large tip may be required to get the help you need! The point, of course, is that while your victim may be watching you like a hawk, he's likely to be innocently trusting of everything set in front of him by the waiter. Any sort of "food" kill, with or without poison note, then becomes possible. One especially nasty one, if

your victim is a sushi lover: arrange for him to get a piece with a triple dose of the green "wasabi" horseradish. A memorable death indeed.

Poisoned Cigarette **Class B**

Various trick devices are available which can be placed in a cigarette to make it taste (ahem) unusual. Any of these makes a good poison. A low-tech alternative is to draw a horsehair or two through the length of the cigarette. (There's a persistent rumor that American cloak-and-dagger types seriously considered an attempt to poison Castro's cigars when he first came to power.)

Pie-in-the-Face **Class C**

This time-honored practice is not exactly "poison" – but where else could we list it? It is designated Class C because of potential damage to the victim's clothes, and immediately thereafter to the assassin's person. If pie attacks are legal, a good solid glop in the face (or on the head) is required for a kill. Common courtesy demands that, at the very least, you pick a flavor the victim likes. A foul-tasting (but clean) substitute pie can be made out of shaving cream.

Firework Smoke **Class D**

Like all other types of fireworks, smoke bombs are against the rules of this game, and against the law in most cities. *Don't use them.*

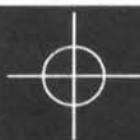

FUTURISTIC WEAPONS

Science fiction fans can play a high-tech version of *Killer* by using devices from the list below. These simulate gadgets which (we hope) are not yet in common use. Just wait a few years, though. Science marches on!

Teleport Gate

Any doorway or other opening, if *completely* ringed by red tape or string, is considered a Teleport Gate. Anyone who passes through it is transported elsewhere – dead, imprisoned, or lost forever, at the whim of the gate's creator. If you pass only partway

through, you can draw back safely . . . so you always have a chance to look around the edge of a door for red tape.

The Bladeless Knife **Class B**

This is a piece of wire so thin and strong that you cannot see it – but stretched across a doorway, it will slice a passer-by in two. (As far as we know, the idea was originated by Winston P. Sanders in a story called "Thin Edge.") It may be represented by a thread stretched across a door or window, beneath a desk, etc.

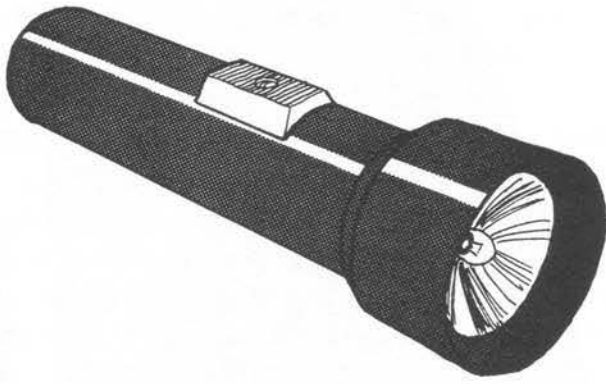

Laser Gun

Class A

Simplicity itself. Get him with a flashlight, and he's dead. Use of different-colored lenses will add realism. DO NOT use a real laser as a handgun; even a low-powered one can damage the eyes if it strikes wrong.

The Deadly Envelope

Class A

Theoretically, this is an envelope full of exotic germs. The idea is old, but fortunately has never become common practice. All that is required is a note saying that the letter has been impregnated with germs. Victims may avoid death by spraying all their mail with disinfectant first, holding it under an ultraviolet sterilizer, or taking whatever other silly precaution you can think of.

Capacitor Zapper

Class A

Today's technology can produce a battery-sized capacitor that will give a nasty shock when you pick it up. Future technology should be able to produce one that kills. A "zapper" need be nothing more than a pill-bottle, possibly painted some bright color, with a ZAP note inside. If the victim picks it up (except with insulated gloves or tongs) he's dead. If he opens it in ANY way, he's dead. *Do not use a real capacitor!*

Radioactive Poisoning

Class A

When this section was first drafted, this was science fiction. We now read that somebody has done it. So it goes. At any rate, the assassin must prepare a pill-bottle or similar object (a cylinder at least 1" in diameter and 2" long) by painting it bright orange and marking it with a radiation trefoil. Once prepared, it may be disguised in any way and hidden in the victim's room or anywhere else the victim spends at least an hour a day. One hidden cylinder will kill in 10 days. Two will kill in 4 days. Three will kill in 2 days.

Shields

Class A

A shield is not a weapon, but a defense. If they are used, they should be expensive in terms of game cash. There can be many types of shields. Some examples:

Shield against bullets – will stop any sort of solid attack, such as knives or bombs, as well.

Shield against lasers – protects against any laser attack.

Shield against viral warfare – radiates on a frequency that destroys harmful microorganisms, and therefore makes you immune to germ-type attacks.

If the victim breaks the thread, he has lost whatever part of his body contacted it. Usually this will be a kill.

If the GM is willing to allow it, the bladeless knife can be represented by something even more subtle – just a pair of marks on the door, showing where the wire is connected. In one way, this is more realistic, because you wouldn't really be able to see a bladeless knife at all. But a careful person would carry a stick to test doors with! Wave it through the door and see if the end falls off. And mere marks on the door frame won't pass that test.

A third possibility is to set a laser pointer (see p. 37) or just a flashlight beam to cross the door about waist-high, so there's no chance it will strike anyone in the eyes. This is totally invisible from outside, but *can* be detected by careful use of the stick test.

Aerosol Virus

Class B

By removing the dispenser head from a can of shaving cream and substituting a spray-paint head, you may shoot a string of shaving cream several feet. This device has some slight potential for property damage, and should be used with discretion. It represents a spray of loathsome virus which will cause the victim to sicken and die quickly if it hits him. (This stuff may also be used as a contact poison in a "modern" game.)

Telephone Sonic Pulse

Class A

If this device is legal, all you need to do to kill someone is call him on the phone and tell him that he's dead. It is assumed that the assassin has played a powerful ultrasonic screamer into his end of the phone, permanently addling the victim's brain.

Shield against radioactivity – protects against radioactive poisoning. Actually an alarm that goes off to warn you of radiation.

Sonic shield – protects against attack by telephone sonic pulse.

The GM may introduce any other type of shield that he wants to.

A shield **MUST** be worn in order to be effective; it protects only the person wearing it. Only one type of shield may be worn at a time.

Blasters

Class A

All kinds of toy ray-guns, from the cheesy to the fantastic, can be found at toy stores and science fiction conventions. It is suggested that only those which produce a loud noise and bright lights be legal. The attacker must be within three feet of his victim – then any shot is an automatic kill.

Beam/Detector Guns

Class A

Sets of “laser” guns and wearable detectors for their beams have been marketed under the trademarks

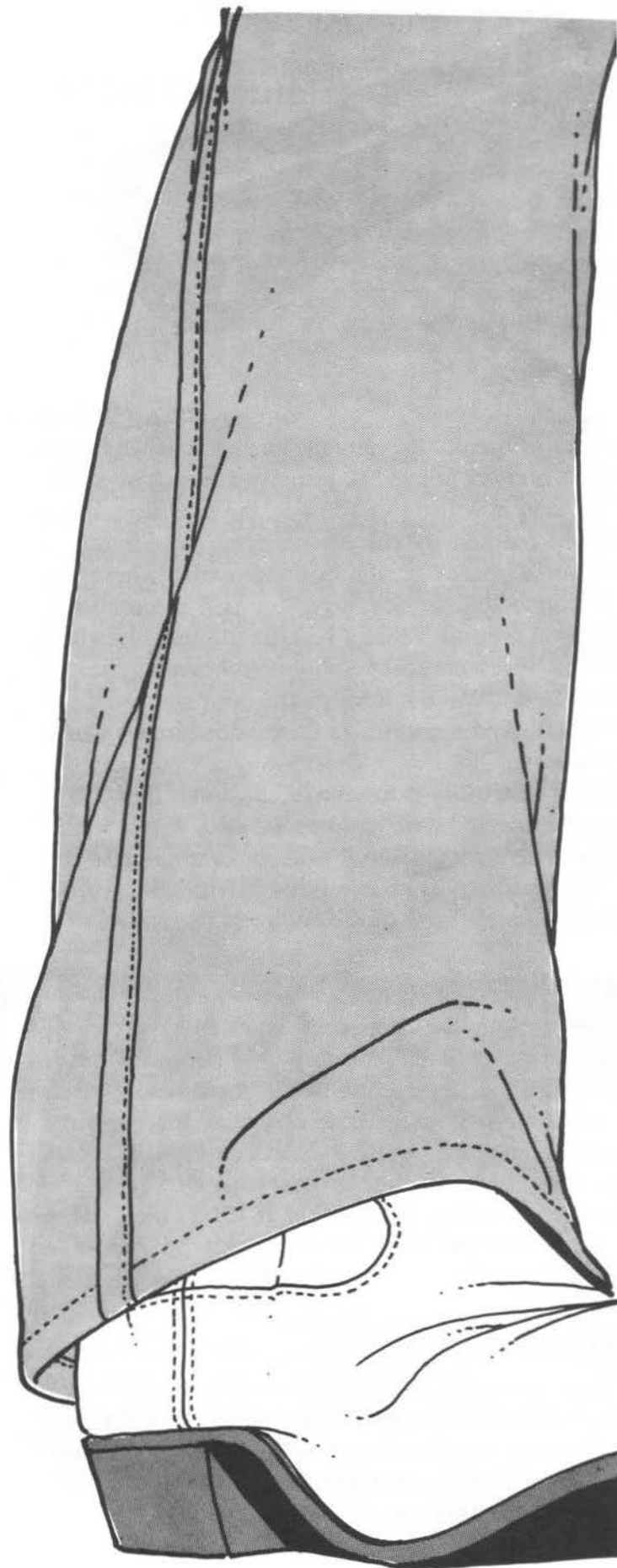
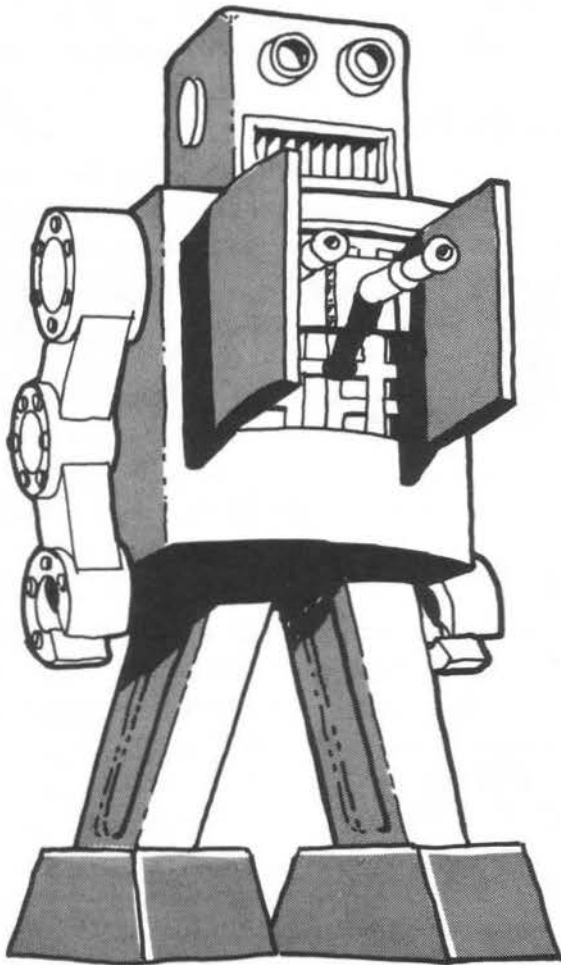

Lazer Tag, Photon and others. These are fun and harmless. The only drawback is that to use them as intended, every player must wear at least one of the detector units as a target. This is sometimes inconvenient.

Umbrellas

Class B

An umbrella can be used two ways. With red tape on the handle, it's a gun; get within 3 feet of the victim, point it at him, and pop it open to score a kill. (Actually, modern espionage agencies build dart guns into umbrellas, so this gadget isn't restricted to science fiction.) With blue tape on the handle, it's a shield. When open, it will stop all kinds of bullets. If the bullet is imaginary – as from an umbrella-gun, banana, etc. – stoppage is automatic. If the bullet is real – as from a dart gun – you have to actually intercept it. The only real danger from an umbrella is that someone may accidentally get jabbed with the tip. Be careful.

Mini-Bombs

Class A

A futuristic scenario would allow even a tiny bomb to be very destructive. See *Bombs*, p. 22, for details.

Clones

Class A

A clone should be VERY expensive. It gives its owner a second lease on life. If you have a clone, it

will come into play at noon the day after you are killed, with all of your memories and property. Your enemies will not know you have a clone (unless you tell them) until that time, but the GM should notify them sometime the day you “rise” that you seem to be alive again!

Robot Killer

Class A

All you need for this one is one of the programmable tanks (cars, robots, etc.) now on the market. If it's a tank, program it to enter the victim's room (or whatever) and fire – thus scoring a kill. If it has no “firing” mechanism, you may have to give it a time bomb or something similar. Not exactly an *easy* way to kill somebody, but impressive.

Laser Pointer

Class C

Real lasers which can send a beam 100 feet or so are becoming fairly cheap. These are very low-powered devices; even so, they could damage someone's eyes. A clever assassin could find ways to use a laser pointer as a “tripwire” or possibly a simulated rifle for a single set-up shot at long range. Don't use a real laser as a handgun; it's too easy for it to go where it's not intended to. And never use a laser in any way inconsistent with whatever warning label it carries.

FIENDISH FANTASY

For a different kind of *Killer* game, try using a fantasy background for your scenario. (Zelazny's *Nine Princes in Amber* is a great inspiration here.) In a fantasy background, primitive weapons and poisons will work . . . but so will magic!

You can play a regular *Killer* game with magic added. But it's sometimes even more fun to leave the lethal weapons completely out. Play to count coup on your foes instead of killing them. How do you do that? Place a *curse* on them!

Curses

Curses are non-fatal but irritating; each one is a command to *do* something, or *not* to do something. Each curse lasts 24 hours.

The GM can create a list of curses and prices. Buy a curse from the GM as you would a bomb or poison; if it fails, the curse is lost. Needless to say, all currency for the fantasy game is in Gold Pieces! Suggested prices: 20 for a trivial curse, 50 for a middling one, 100 for a major curse and 250 for a catastrophic one.

Any “poison” or “bomb” device can be used to deliver a curse. If you trigger it, you're not dead or hurt. Instead, the curse takes effect. Thus, there must be a note telling you how you have been cursed! A few examples . . .

Trivial

- Victim must answer to the name “Fluffy.”
- Victim may not use the words Yes and No.
- Victim may not write except in red ink.

Middling

Victim cannot eat or drink anything when anyone is watching.

Victim must smile and be cheerful constantly, saying nothing negative.

Victim must wear a truly stupid hat or other item of clothing.

Major

Victim must snap his fingers after every statement he makes.

Victim must hop on one foot as long as he's within game bounds.

Victim may not speak or write anyone's name.

Catastrophic

Victim may not speak.

Victim cannot attack other players!

Victim must answer all questions truthfully.

When you are cursed, you must immediately notify the GM that you have been cursed. It is his job to publish the terms of the curse so that everyone will know what you must do or not do.

This lets non-players get into the act. If you're supposed to be cheerful all day, then *anybody* can say "Hey, how's the old curse going?" – and tell the GM if you don't smile.

Accidental failure to comply with the terms of a curse leads to a penalty (maybe just a fine or loss of points, maybe a further curse). Deliberate refusal means you lose the game.

The object of the curse game, then, is not to kill your foes – it's to drive them crazy, and to demonstrate your own cleverness, by repeatedly zapping them. That makes it a good variant to use if you're surrounded by busybodies saying "Yeccch! You're pretending to *kill* people?" Of course, they may get upset at curses, too . . . Life is hard.

Other Fantasy Ideas

Remember, this is a world where magic is real. To make things more interesting and obnoxious, go for atmosphere. Let everyone adopt a pretentious medieval-sounding name and title, and use it at all times. Instead of snakes and bugs, plant little rubber monsters (demons?). If weapons are in use, some of them could be *magical* – likelier to wound or kill, but very costly and with names of their own. And so on!



EXOTIC MURDERS

Guns and bombs are good enough for an everyday assassination – but once in a while, one of your friends will deserve something special. And some of us wouldn't be caught dead (so to speak) running around with an ordinary dart gun. Here are a few suggestions for extraordinarily strange and peculiar murder methods. These are all Class A – harmless except to the victim's nerves. Have fun . . .

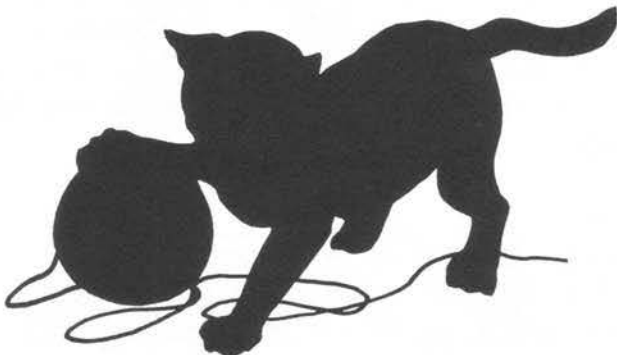

The Case of The Fiendish Feline

Your victim must share living quarters with a cat – preferably a very friendly, cuddly one. Borrow that cat, by fair means or foul, and paint its claws with colored nail polish. Then return the cat. Its nails are now covered with a virulent poison!

If your victim notices the cat's new adornment, he has escaped your trap. But if he doesn't notice, and picks up the cat and cuddles it, he has been poisoned! The cat does not have to *really* scratch him – it is just assumed that picking up the cat, or letting it jump onto his lap, is enough to finish him off.

The Case of The Invisible Insects

This trap requires a large box, at least a foot on a side. On the outside, write "You hear a buzzing noise," or something of the sort. (A tape recorder to produce a *real* buzz would be very classy!) A note inside says "Killer Bees," – and that's what is in the box. Set it up like a bomb – but the triggering mechanism must actually *open* the box.

If the victim finds the box and keeps it closed, he's safe. If it opens – or if *he* opens it without appropriate precautions – he has been stung to death by thousands of African killer bees. If you're scoring points for especially nasty murders, this one should get credit for fiendishness.

The Case of The Perfidious Plant

This murder requires special equipment . . . one of the "moisture alarms" used to detect seepage in basements. It is a small electronic gadget that buzzes loudly if it gets wet.

Acquire such a device and bury it in a flowerpot at your victim's house. If your victim notices that the plant has been disturbed, he can call the bomb squad, or dig it up himself, and be safe. But if he carelessly waters the plant, the buzzer goes off. BOOM. And he thought gardening was good for his health . . .

The Case of The Toxic T-Shirt

The only equipment needed for this murder is a piece of Velcro fastening material. Use the "hook" side, rather than the "eye" side. This represents a scratchy pad soaked in poison; you should use a piece at least 1" by 2" to give the victim a fair chance to notice it.

Use a safety pin, or a few loose stitches, to fasten this pad *inside* an article of the victim's clothing. This will be much easier if the clothing is not being worn at the time! The neck-band of a T-shirt, or the waist of underclothing, are good locations.

If the victim sees the Velcro before he gets dressed, he's safe and can remove it. But if he doesn't notice it until he puts it on and feels the scratchiness . . . good-bye!

The Case of The Voodoo Vendetta

Welcome to the Dark Ages. Acquire a small doll and customize it to look like your victim. Unsavory accumulations of hair, etc., are *not* required – just get a physical likeness! Then drive a pin through its heart and hide it under the victim's bed. It *has* to be under the bed – no place else will do.

If your victim sleeps over the voodoo-doll for enough nights, he will die. The more the doll looks like your victim, the quicker it will act. A perfect likeness will work in a single night; a less skilled job might take as long as four nights. The GM is the judge; show him the doll *first*. If the victim discovers the doll before he dies, the murder has failed, and you cannot try this method on him again.

This murder should be worth points for pure *strangeness*. In fact, if your victim is actually superstitious, you shouldn't use this one at all; an ordinary dart gun would be much kinder.

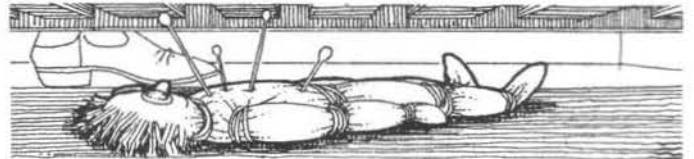

The Case of The Cloistered Key

This one will work only on someone who trusts you. But then, your friends are the only ones you can stab in the back; it's impossible to betray your enemies. That's the special thing about this murder . . . it's not especially outré, but it's incredibly cold-blooded.

You must know where your victim keeps his spare house or car key. Booby-trap that place, using either poison or a bomb. Now, the next time your victim needs his spare key, he's dead.

But how can you make sure he needs that spare key in time? Easy. You borrow his regular key . . . which he trusts you with . . . and "forget" to give it back . . .

GROUP ATTACKS

Melee combat (a roomful of people attacking each other in various ways) is to be avoided – it is inelegant, confusing, and totally opposed to the “spirit” of this game. In general, physical contact with the opposition ought to be avoided when possible. Direct weaponless assault, when it must take place, is simulated in one of the following ways.

Trapping

Class A

If two or more killers can trap a victim in a room for ten minutes, they may assume that he has been killed by fire, poison gas, etc. The victim must be alone and all means of exit must be blocked. If the

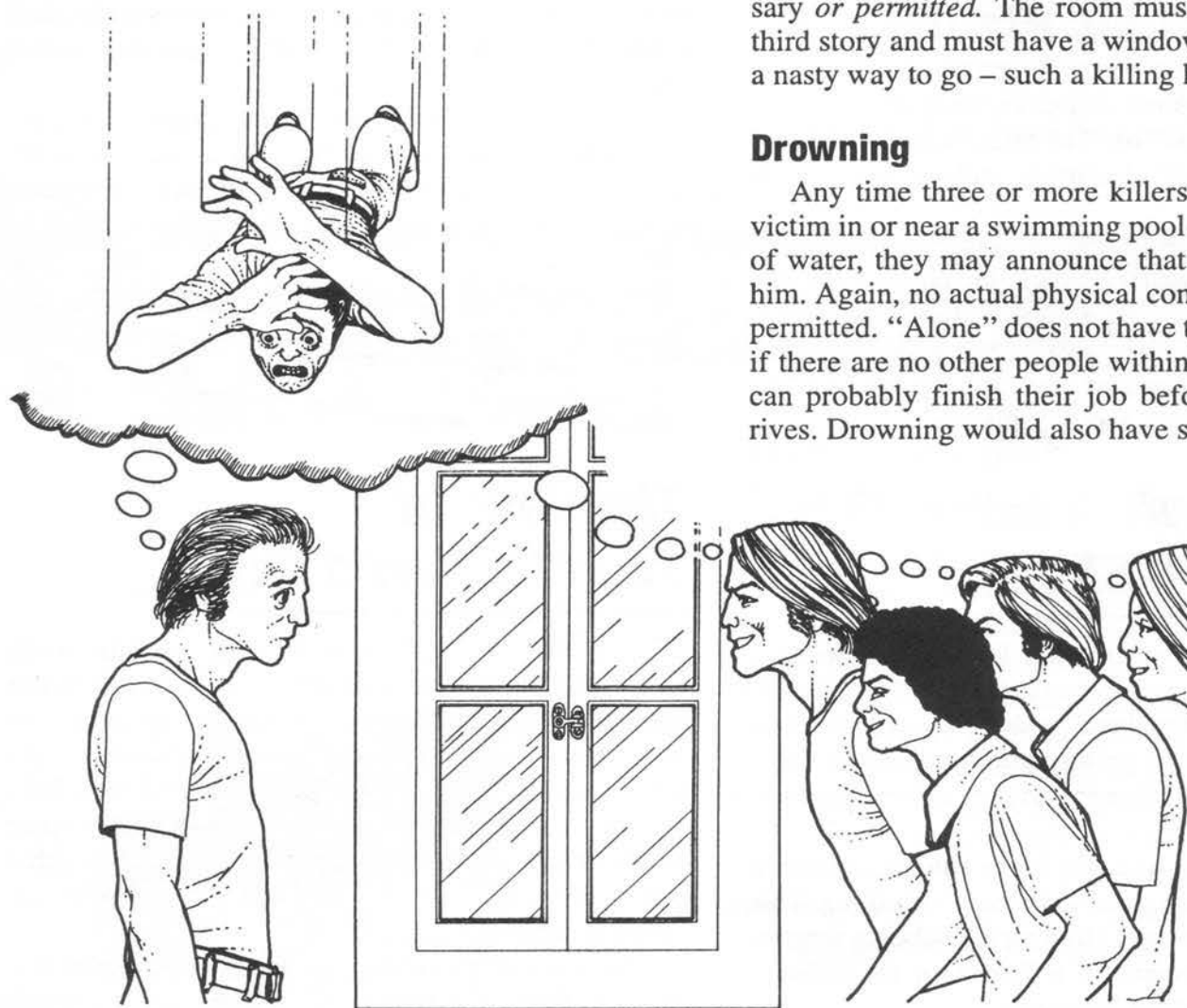

victim has any way to call for help, he will probably do so. If anyone (player or not) arrives within the ten minutes, the killers must leave!

Simple Mugging

Class A

Any time three or more killers are alone in a room with one victim, they may announce that they are beating him to death with whatever comes to hand. No actual physical contact is necessary *or permitted*. This type of killing lacks class but is unfortunately realistic.

Defenestration

Class A

Any time five or more killers are alone with one victim, they may announce that they are throwing him out the window. No actual physical contact is necessary *or permitted*. The room must be on at least the third story and must have a window. Defenestration is a nasty way to go – such a killing has “horror” value.

Drowning

Class A

Any time three or more killers are alone with the victim in or near a swimming pool or other large body of water, they may announce that they are drowning him. Again, no actual physical contact is necessary or permitted. “Alone” does not have to be taken literally; if there are no other people within 30 feet, the killers can probably finish their job before interference arrives. Drowning would also have some horror value.

Any unarmed “group attack” is an automatic kill if the requirements for the attack are met.

All “group attacks” listed here presuppose that the victim is unarmed. If the victim has any sort of weapon, he/she is free to use it on the would-be killers.

SCENARIOS

Each of the following scenarios gives a different background and set of special rules. *Killer* is never the same game twice. You can make it as simple or as complex as you like . . . a team sport, or every man for himself . . . in the past, the present, or even the future.

The Circle Of Death

This is the oldest form of the game, and the simplest. At the beginning of the game, the GM assigns each player a single victim. Each player is also the assigned victim of a single assassin. Thus, A is stalking B, B is after C, C is after D, and so on . . . down to Z, who is trying to kill A. Upon completing a successful kill, you must find out from your victim (or the GM) who your *victim's* target was. This person then becomes YOUR new target. If A kills B, he is then after C, and so on . . .

Nobody knows who his assassin is . . . unless the assassin reveals himself, either deliberately or by making a clumsy attack. If you find out who your assassin is, he is fair game for *you*. As always, bystanders may not be endangered. If you kill your assassin (or if he is killed by his own assassin) then the person who was originally stalking your assassin will now be after you.

Since deaths may occur for a variety of reasons, your target may die through no action of your own. Therefore, it is a very good idea to have a bulletin board, on which deaths are posted as the GM finds out about them. If you see that your victim has been killed, you must immediately find out who your new target is.

Eventually, the circle will shrink to two people – each stalking the other. The survivor of the final encounter is the winner.

If a Polaroid camera is available, the GM may take a picture of each player at the initial meeting. This can then be given to a killer, with (or without) other information, as part of his assignment. If everyone in the game knows everyone else, this will not be necessary.

“Circle Of Death” is a good “warm-up” to use as a group’s first scenario. It can be challenging, though . . . especially when the players have no idea how many others may be in the game or even who they are.

Five Targets

Each player is given the names of *five* other players. These five (and only these five) are his assigned victims. He must kill as many of them as he can during the course of the game. A time limit of about a week works best.

Each player is also a target of *five* other assassins. They are all trying to kill him. Should one of them succeed, the victim must acknowledge the death, but keep playing. During the course of the game, a player might die five times and kill five other players.

If a victim kills one of his assassins, that assassin may not try for him again. No two players should be assigned to kill each other. This means that a minimum of 11 players, plus a GM, are needed for this scenario. (If each player has 4 victims, 9 players will be needed. If each player has 3 victims, only 7 players will be needed.)

Score points as follows: For each victim killed, 2. For each time you die, -1. For each assassin killed while trying to kill you, 3.

Competition

From three to six assassins are competing to see which of them can kill a single target first. They may or may not know each other. Any assassin is fair game for any other. The assassin that kills the victim is the winner. Of course, the victim can shoot back! If the victim can last a specified time (say, three or four days), all the assassins lose, and he wins.

Targets Of Opportunity

This is a genuine free-for-all. Each player knows the names and addresses (possibly more) of ALL the other players. Each player is fair game for any other player. The last survivor is the winner. Alliances may be made, but they are not likely to last very long.

The GM may vary this game by letting new players into it after the beginning. If this is done, then (to be fair) deceased players should also be permitted to

re-enter the game a set time after their death. The winner is the person who scores the most kills during the time the game runs, with each death of his own counting as a one-kill penalty. The full system of scoring may be added for more complexity.

This game is another good “warm-up” before a more complex scenario.

Single Contract

This game lasts for a specified time – say a week – and then ends. The GM writes the name of each player on a slip of paper, mixes them up, and then pairs them randomly. Each person has one victim, and each person is the assigned victim for one assassin – but there is no order to the pairings, except that your victim may not also be your assassin. This one works well if all the players know each other.

If you successfully kill your victim, you do not get another victim – you just try to stay alive for the rest of the week. If you are killed, you can still go after your own victim . . . *unless* he was the one who killed *you*. If you find out who is trying to assassinate you, you *may* try to get him first. The objective is to kill your own victim without being killed; therefore, there can be multiple winners. At the end of the week, start over. The GM may award prizes for especially creative slaughters – or it may be done by a vote. The one-week time span allows for some fairly elaborate plans.

Team Killer

The GM divides all the players into two (or more) teams. The objective of each team is to wipe out the other teams while keeping at least some of its own members alive. The basic game is as simple as that, but a number of variations are possible:

(1) If each team is drawn from a different group (school, dormitory, department, or whatever) then players probably will not know members of the other team by sight. Each team starts out knowing only the *names* of the members of the other team, and must do their own spotting.

(2) This may be carried even farther. Each team starts out knowing the names of only a *few* members of the other team – say its leader and a couple of others. Each player may have up to ten yes-no questions a day to be asked of the GM in order to learn the identities of

other enemies. Of course, anyone seen with a weapon may usually be assumed to be a foe.

(3) The roleplaying rules work well when added to a multi-player multi-team game. Players then have an incentive to sell each other out, and paranoia is thereby increased. If players are earning points individually, being on the winning team should be worth a 50-point bonus.

(4) One player on each team, chosen randomly by the GM before play begins, may be a *traitor*! Only the leader of the other team (and the GM) knows this at the beginning of the game. A leader may tell his other team members who their “spy” is – or keep his identity secret and let him fend for himself. The traitor must choose between blowing his cover in a single treacherous attack, or working from within to feed information to his teammates and “set up” killings to be performed by others. Anyone can kill a teammate at any time, in hopes they are eliminating the traitor. Of course, they may be wrong . . .



The Hidden Prize

This scenario is a variant of Team Killer, using several teams of two players each. The town or city where it is played should have a bus station, airport or other area with public-access lockers (the kind with the numbered keys). This is not necessary, but it makes the game more fun. The goal of each team is to collect enough clues to figure out the number of the locker that holds a prize that all teams are seeking. The prize can be whatever the players decide on. (One idea is to

have each player contribute \$1 or \$2 to a fund, and have the GM purchase something – a dinner for two, tickets to a concert, etc.) Before the game begins, the GM should actually place the prize in the secret locker.

Each team starts with one clue written or typed on a small piece of paper. This clue represents the best guess of that organization's intelligence network. The total number of clues can vary, but should never be less than four. Each team should have two members. One is the clue-holder, and the other is a free agent, either playing defensively as a bodyguard, or offensively as an assassin . . . usually *both!* The clue-holder can also assassinate other teams' members, but runs the risk of being killed himself. The clue-holder must carry his team's clues on his person any time he is not in a safe area.

When the teams are chosen, each must decide who is going to be the clue-holder and give this information to the GM. Teams may switch clue-holder and free agent at any time, but they must inform the GM *before* the switch takes place. Teams should know who are members of which teams, but not which member is the free agent or clue-holder.

If a team's clue-holder is killed, the killer gets that team's clue (or clues, if they've acquired some from other teams). A clue-holder who is killed by a bomb or some other indirect method is required to pass his clues to the GM, who should give them to the proper assassin. If the assassin is a team's free agent, he must *immediately* take the clues to his clue-holder (in which case he may be followed, opening the way for some ingenious strategies). He may not detour or try to collect more clues. When a team's clue-holder is killed, the free agent becomes the clue-holder (even though he won't have any clues right away).

Once a team's members feel they have enough clues to guess the number of the secret locker, they should write down the guess and give it to the GM. This can happen at any time. If they've guessed right, the GM should give them the key to the locker and they can proceed to the building containing the locker and pick up the prize. *But the game is not over!* If one of the remaining teams manages to kill the team member with the key, he can take the key and try to get to the locker. Once whoever has the key makes it inside the *building* containing the secret locker, the game is over, and his team gets to keep the prize. *Under no circumstances should any of the players take the game into a public building! An airport is the stupidest imaginable place to play with toy guns!*



What if there are no lockers in a convenient place? In that case, the "key" can be a set of directions to the place where the prize is hidden. If a suitable hiding place is found – perhaps out in the country – it's possible to let the game continue right up to the moment when the prize is recovered . . . or even until the moment when the prize is returned to the home of a player! The GM should carefully define when the game ends.

Or, if there's no good hiding place to be found, just end the game when someone personally delivers a correct guess to the GM. Instead of handing them a key, just give them the prize.

If a team makes an incorrect guess about the locker number, they are out of the game. The local police caught them trying to break into someone's locker and they were arrested. All of their clues go to the GM, who must distribute them to the remaining teams. There are several ways to accomplish this. The GM could just divide them up randomly. Or he could put up an announcement on the bulletin board, and then give one or more clues out to whoever shows up first

at a predetermined “safe” location. He can either give out all the clues to the first to arrive or give one to each person to show up until the clues run out. Alternatively, the GM could “sell” the remaining clues to the highest bidder (using fake money, of course). This represents a bribed officer leaking information.

Note that one does not have to actually *possess* all of the clues to figure out the secret locker number – he just has to *know* them. The free agent of a team is allowed to write down his team’s clues and use them even after those clues are taken by another team. If the assassin is killed, he is not required to give up any clues he may know . . . *unless* they are on his body when he is assassinated!

The Clues

The GM should devise his own clues based on the examples below. The clues should be such that a team must collect all of them to be *absolutely* sure about which locker is the secret one. If there are five clues, then having three would narrow the possibilities down to between three and ten, having four would limit the choices to two or three, and having all five would reveal the number as long as the person with the clues followed them logically.

Sample clues could read “the first digit is the same as the last,” “the position of one of the digits is the same as the digit itself,” “two of the digits are the same,” “there are no even digits,” etc. All players should be told at the outset how many digits are in the number. Following are three sample locker numbers with appropriate clues. The GM can use these if he wants, but should keep in mind that players can simply buy a copy of this book and look up the numbers. It would be safer for the GM to use the following examples and construct his own locker number and clues.

Example 1

This puzzle has five clues. The locker number is 765.

1. The first digit is larger than the third.
2. The digits are in sequential order, either ascending or descending.
3. One of the digits is 5.
4. There is only one even digit.
5. The first digit is not 5.

Example 2

This puzzle has six clues. The locker number is 9537.

1. None of the digits repeat.
2. The first digit is the largest.
3. One digit is 3 times another.
4. There are no even digits.
5. The digits total 24.
6. The sum of the first two digits is equal to twice the last digit.

Example 3

This puzzle has seven clues. The locker number is 1266.

1. Two of the digits are ascending sequential.
2. Two of the digits are the same.
3. The last digit is 3 times another of the digits.
4. One of the digits is 1.
5. There is only one odd digit.
6. The second digit is 2.
7. The digits total 15.

Variations

Number of Players

One of the difficulties of running this scenario is getting the right number of teams from the players available, especially if there are an odd number of would-be players. There are a number of solutions. Depending on the number of available players, the GM can make teams of one (for small groups) or three (for very large groups). Players who opt to “go solo” can be given two clues to start with, while teams who choose to start with three players get no starting clues. Teams of more than three are not recommended.

False Clues

An especially fiendish idea would be to give some of the teams false clues, with no indication as to who has the true ones and who has the false. It is important, however, that each false clue be the direct contradiction of a true one, so that logic could still be used to figure out the number (though it would take longer). For example, if one clue reads “one of the digits is 6,” a false clue could read “one of the digits is not 6” or “there are no even numbers.”

This variation works best when there are lots of people who want to play. Rather than try to create an eight-clue problem, the GM can create a five-clue puzzle and throw in three contradicting clues. Of course, there is now the chance that *nobody* will get the correct number.



The Bodyguards

This is a two-team game, although the teams can be very small. One player represents a single Godfather. The rest of his team represent his bodyguards. The members of the other team are assassins sent to eliminate the Godfather.

At the beginning of the game, the assassins all know who and where the Godfather is. They do not know who the bodyguards are. The bodyguards do not know who the assassins are or how many there may be.

The game runs for a fixed period of time (say, a week). The assassins win if they get the Godfather. The bodyguards win if the Godfather survives, and win decisively if they have killed most or all of the assassins. Once a bodyguard (or assassin) has been conclusively spotted by the other team, he/she may be killed at any time or place that is not off-limits . . . but the usual penalties for a mistaken killing are in force.

This game calls for strategy. The leader of the assassins may deliberately sacrifice a couple of his assassins in order to “spot” the bodyguards . . . or he may attempt a diversionary tactic. For this scenario, it may be assumed that both assassins and bodyguards are willing to die if it will help their side win.

If the Godfather’s team is winning too easily, you may vary the game by assuming that the Godfather is a very old man . . . perhaps ill. He cannot carry weapons, but must depend on his bodyguards to protect him. A compromise would be to allow him a single-shot dart gun for emergency use.

The Agents From 2080

This is a science-fiction scenario – set in the present. A small team of time-travelling agents has come from the year 2080. Their mission . . . to alter world

events so that their future can come about. To do this, they must first defeat a crack team of present-day intelligence agents.

The future team may use weapons from any period. Naturally, they are likely to choose such effective nasties as the bacterial spray and the flashlight laser, since these are quicker and more accurate than dart guns or water guns. They also have the advantage that their future bombs are more effective than present-day ones. However, their team is very small – say, three people – and they cannot use accomplices. They also cannot use their futuristic defenses, like shields.

The “present” team should be two or three times as large. They cannot use the future weapons, even if they capture one (it will self-destruct). They may use any primitive or modern weapons the GM allows.

At the beginning of the game, the “future” players are all unknown to the present-day agents. From half to two-thirds of the present-day agents are known to the killers from the future. Every two days, the GM will give the future players one of the unknown names (of course, the future players may have found out about that person already). The game ends when one side or the other is wiped out.

This is not a good scenario for roleplaying, since the players already *have* roles. If you like, you can keep track of points to see which of the killers performs most skillfully.

The Bomb Builders

This scenario may be played with either modern or futuristic weapons. One team represents a group of enemy agents assembling a nuclear device to destroy a city. The other team represents a team of security police attempting to deal with the menace.

The GM will prepare a batch of “bomb parts,” labeled A through J. These may be any small objects; pill bottles or small boxes work very well. In order to detonate their bomb, the agents will need to get all ten parts together in the same place.

At the beginning of the game, the security men know the identity of the enemy team leader. The agents know the identities of at least half of the security police. Suggested team size is six to eight players apiece. If one team is larger, make it the security team.

The GM represents the agents’ “contact,” as well as refereeing the game. The security forces may shadow him, but may not kill him – that would only

make their mission more difficult. Each day, the GM will give the bombers one piece of the bomb. He may be as secretive about this as can be managed – however, the GM should make the agents do all the planning. He should not use his own cleverness against the security team – thus, he remains impartial. Bomb parts may be delivered through intermediaries, by “drops,” etc. – whatever the agents can devise.

Once each bomb part is received by the agents, they may take it to their “bomb assembly site.” This may be absolutely anywhere except an off-limits area. Bomb parts may be left at the assembly site, or carried on the person of one or more agents – there are no other options. The assembly site may be moved, but only one assembly site is allowed at a time.

If the security forces kill an enemy agent, they get any bomb parts on his person. Any captured parts must be returned to the GM – “taken to headquarters for study.” The agents may recapture a part by killing the security man carrying it. Bomb parts captured by Security may never be hidden – they must be carried on the person of a security man from the time they are captured until they are delivered to the GM. Delivery must be in person – no “drops.” For this reason, the actual residence of the GM should be off limits – but areas leading to it should not be off limits, thus encouraging ambushes.

Security may capture a number of parts at once if they find the assembly area. Again, captured parts must be personally returned to the GM.

The GM will reissue captured parts to the bombers at the rate of one per day, after all original parts are issued. If some accident destroys a part, the GM will make a replacement. To detonate their bomb, the agents must assemble all ten different parts in one place.

Figure victory as follows:

If the agents can assemble the bomb, leave the assembly area, and wait an hour before informing the GM of the finished assembly – they score a *decisive* victory. The GM will go to the area (or send someone) to verify that the bomb is complete and has not been found in the interim. At that point, it “explodes” – and the agents have already escaped safely.

If the bomb is detonated immediately upon assembly (eliminating the agents as well as their target city) – agent victory.

If all security men are killed, the agents automatically win.

If all agents are killed, the security men automatically win decisively.

If the game continues for 20 days and the bomb has not gone off, the security men win, though not decisively.

For a shorter game, use only six bomb parts.



Three-Team Version

This version was first played at a Tulsa convention; it ended in the destruction of the city. The nuking terrorists are opposed by *two* other teams, representing, respectively, Interpol and the CIA. Unfortunately, members of the two law-enforcement teams do not know each others' identities, and are likely to blow each other away unless they can somehow establish trust. And, of course, the terrorists will try to muddy the waters as much as possible.

Couriers

This game is similar to the “Bomb Builders” scenario, but it is *much* shorter – it can be played out in a weekend or less.

Two teams of players, and at least *two* GMs, will be required. One GM plays the “contact” for each team. Of course, both GMs must be impartial in their deci-

sions and should consult each other before making any important rulings during the game.

At the beginning of the game, each team leader is given a "message capsule," which may be represented by an envelope, pill-bottle, or other small object. Message capsules should be unique and uncounterfeitable. The GMs must give the leaders the capsules in a place distant from their final goals – described below – and must take precautions to insure that the leaders are not immediately slaughtered.

Each team's object is to get its own message capsule, AND if possible the enemy's as well, to its own contact. The two contact GMs should therefore stay at home throughout the game – and they should live at least a quarter-mile apart. The actual residence of each GM is off limits – once a player gets in the door, he is safe.

Each player should be known to all the others, since this game does not allow time for shadowing and identifying a foe. If a witness rule is used, at least two witnesses should be used – and the players will want to have masks available.

A message capsule may be hidden anywhere (except in an off-limits area) by any living player.

Special rule: To speed up the game, each player who is killed is allowed one "dying message." This dying message should be telephoned to the contact GM as soon as possible after the player is killed. Enemy players may not listen in! The GM will repeat the message to whichever member of that player's team is next to call. Messages should be short. Sample messages:

"68 and 33 shot me at the ice-cream stand and took the capsule. Aagghhh . . ."

"They got me, but they didn't get the capsule. I hid it in the flowerpot in my window . . . Oohhh . . ."

"This is Red. They got me, Chief, but I took one of them with me. I . . . I . . . (gasp) . . ." (It is to be hoped that this player had nothing *important* to say!)

Dying messages take most of the secrecy out of the game – it becomes a battle of stalking and reflexes.

If a player has a message capsule on his person when he is killed, he must give it to his killers. If the encounter leaves no survivors, the capsule must be left where it is, and all of the newly-dead players may phone in their dying messages. This will result in a race for that spot!

A capsule must be delivered by the time the game ends, or it does not count for either team. A team wins if it gets *both* capsules to its contact (or gets only one

to its contact, if the other one is never delivered). If each team delivers one capsule, the team with the most survivors is the winner.

This scenario works very well with "wounding" rules. A wounded player cannot fight, but can still try to deliver the capsules . . . or simply stay at home and relay messages. "322? This is Central. Take your team and prepare for an intercept at Point 5. Anticipate at least three hostiles."

Chicago 1920

This is a specialized variation of Team Killer. Each team represents a gang of Prohibition-era hoodlums, fighting to see who controls the city's "action."

Each team is led by a Godfather. The GM may assign Godfathers at the beginning of the game, or let gangs choose their own. If a gang's Godfather is killed, the gang may elect a new one – or break up and let its members join other gangs. A Godfather may resign at any time; the effect is the same.

Each Godfather may name one lieutenant (or two, if there are more than six members of the gang). If a lieutenant is killed, or resigns, the Godfather chooses a new one. This also takes place if a lieutenant publicly changes loyalties.

Any player may change gangs at any time, with or without notifying the other players. He **MUST** immediately notify the GM of the shift in loyalties. The GM keeps track of which gang each player **REALLY** belongs to, since players get extra points for being on the winning side. Nobody but the GM and the player knows for sure where anyone's loyalties lie.

This scenario should use money (for bribes and buying weapons). Each player starts off with \$100. Each Godfather gets an extra \$500 to spend or distribute as he sees fit. In addition, each player draws a daily "rake-off." Godfathers get \$50 per day; lieutenants get \$20, and ordinary button-men get \$10.

This scenario is also tailor-made for roleplaying. A player may let his "character" be known . . . or keep it secret. Or he can lie. Remember: if your character is known to the other players, you will be more predictable.

You can begin with all players known to each other, or with only some players known, as described for earlier scenarios. The Godfather of each team, and probably at least one lieutenant, should be known to all players.

Gangs may join forces if they wish, either formally or informally. If two gangs actually merge, there can be only one Godfather and at most two lieutenants. Similarly, a new gang can be started by four or more players at any time, by notifying the GM. He will then start paying the salaries of the new Godfather and lieutenant(s).

Special point values for this scenario only:

Killing a Godfather – 20 points extra

Killing a lieutenant – 10 points extra

For each Godfather at the end of each day he survives – 10 points

For each lieutenant at the end of each day he survives – 5 points

For being on the winning gang when it is over (GM's list) – 10 points

For being on the winning Godfather's list of those *HE* considers loyal when the game ends – 20 points. The Godfather makes up this list (the roster of all those he wishes to reward for apparent loyalty) and gives it to the GM at the end of the game.

This is an *especially* back-stabbing scenario. The higher salaries paid to Godfathers and lieutenants mean they can try to buy loyalty . . . but jealous underlings may try to kill their own team members, or even their own leaders. The intrigue between and among gangs can get very fierce.

The game may end (a) when only one gang is left, (b) at some pre-arranged time, (c) when one Godfather accumulates \$1,000 with which to bribe the Commissioner to throw all his opponents into the slammer, or (d) when other surviving gangs choose to throw in the towel and acknowledge the dominant gang's leadership. The GM should choose the victory condition(s) and announce them in advance.

The Borgias' Game

This is a medieval scenario – Renaissance Italy, to be exact. Players represent feuding noble families and/or guilds. All dollars become “ducats.” Only “primitive” weapons and pistols may be used. Bombs of the gunpowder-keg variety are legal. But poisons . . . aaah, yes, poisons . . . *that* is the true Borgia method.

The GM divides players into *families* at the beginning of the game. Each family bears a unique last

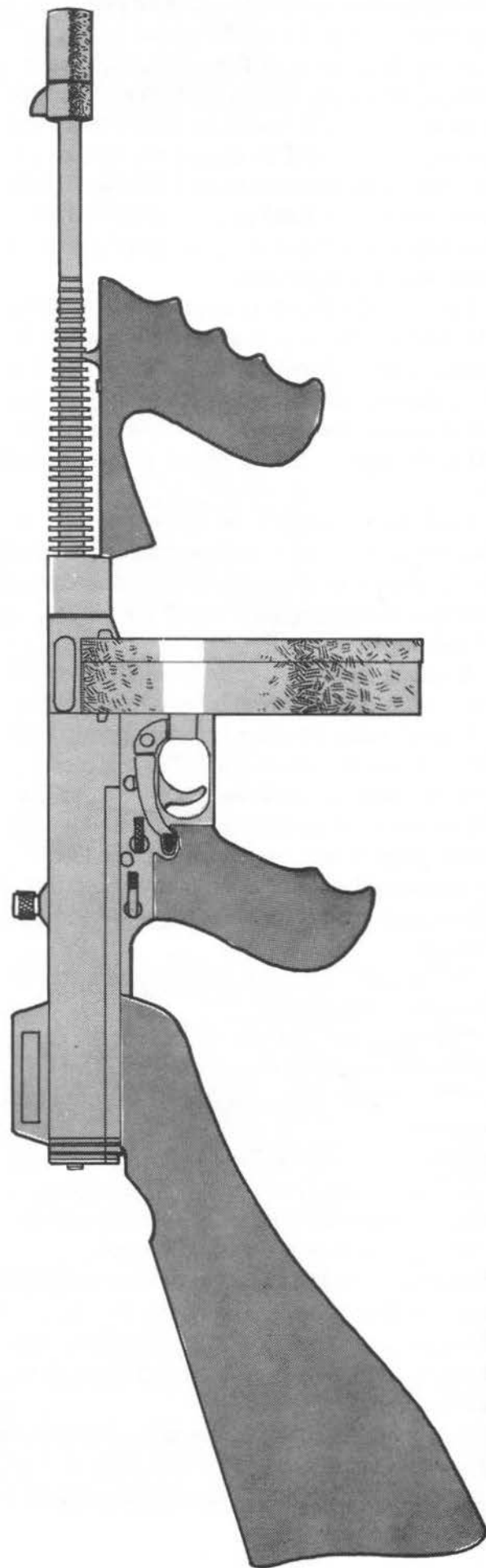

name – players may choose their own first names. A player who is actually a member of the family (that is, bears the family name) may not join another family. (He *can* intrigue against other family members, but cannot actually switch sides.) A “hireling” is a player who was recruited later in the game, or a beginning player who chose to start as a hireling. Hirelings may switch sides at any time by informing the GM (as described for the Chicago 1920 scenario).

Each family chooses its head at the beginning of the game. All family relationships should be defined at this time. If the head of the family is killed, leadership goes to his oldest surviving son. If he has no eldest son, it goes to the oldest of his surviving brothers. If no one qualifies (or if they decline the honor) then the family puts it to a vote. This is the only way a female player can become head of the family. (Yes, Renaissance Italy was highly sexist.)

The GM gives the head of each family 500 ducats per day, to spend as he/she wishes. Weapons, poison, hirelings, bribes, etc., all are useful expenditures. Or he may just stash it away to try for a win on wealth.

Duels are very important in this scenario. No female may be challenged to a duel. No male can honorably *refuse* a duel if challenged. Treachery during a duel is quite possible, of course.

Players may recruit freely during this game, within the limits of their funds. A player who enters the game after its beginning is a “hireling.” A hireling can do anything that one of the original players can, as far as assassination goes. However, each hireling must be paid 50 ducats per day by the family for whom he is (theoretically) working. (If a hireling can successfully betray his original employer, he may collect two or more stipends each day, until his original employer finds out and stops paying him.) Players may pay their hirelings extra if they like. A hireling can employ hirelings of his own, if he can afford it. Any new hireling must be reported to the GM, so the records can be kept straight and the new player can be given a copy of the Contract.

If a hireling is not paid by noon, he may not kill anyone that day (until he is paid) but may still defend himself or act as an accomplice if he is willing.

A Family wins when the actual (named) members of opposing Families are dead, or announce their surrender to the GM. Individual victories are calculated according to point scores. In addition to normal points, score for the following:

- Killing anyone by poison – 10 points extra
 - Killing in a fair duel – 15 points extra
 - Killing treacherously in a duel – 5 points extra
 - Refusing a challenge to a duel – 10 point penalty
 - Being a member of the winning Family – 50 points
 - Being a hireling (according to the GM’s records) of the winning Family – 10 points
 - Being on the winning Family Head’s list of loyal hirelings (either overt or covert) – 15 points.
- The head of the winning Family makes up this list at the end of the game and gives it to the GM; it names everyone that *he* feels is a loyal hireling and should be rewarded.

One On One

This is a team game, but it starts very simply . . . one player on each side. However, each player can *recruit* freely – so it soon mushrooms. New recruits may also recruit, and so on. However, each recruit must get a copy of the Contract from the GM – see *Recruitment*.

This game may be used with money and roleplaying, but it works very well without. It is probably more fun when a point system is used. Each player gets as many points as possible before (as will inevitably happen) his cover is blown and he is killed by the other side. Eventually, both sides will run out of players (or energy). At that point, the game is over, and the highest-scoring player wins. If one team has been totally wiped out, all players on the other team get a 10-point bonus, or a 20-point bonus if they are still alive themselves.

Recruitment becomes vitally important, not only to make up losses and build a bigger force, but also because new players are the most effective. The opposition will not know who their new enemies are except by observation. Thus, new agents are the ones most able to pull off a kill. Older survivors will be known to the enemy and will have to spend more time on the defensive.

Variation 1

Each player may *either* attempt one kill *or* recruit one new player each day. If a team is down to one player, he may attempt one kill *and* make one recruitment in one day. This rule keeps the game under control and rewards planning and strategy.

Variation 2

Each day, the GM rolls one six-sided die for each previously unrevealed player. On a roll of 5 or 6, he gives the name of that agent to the opposing team. Everybody's cover gets blown pretty quickly with this rule.

Vampires

This scenario may be set in any time period. After all, vampires have been around for a long time! For reasons which will become obvious, it works best in a group that is about evenly divided between the sexes.

At the beginning of the game, one player, known only to the GM, is a vampire. His objective is to survive; he can best do this by eliminating all the other players and/or by turning them into vampires! The other players, of course, also want to survive. As humans, they must resist the vampire fiercely. The vampire may kill them, taking them out of the game. But if a human is bitten and becomes "undead," his loyalty changes to the vampire side!

Weapons are used as appropriate to the time period chosen. However, vampires are immune to all weapons *except* those made of wood. Thus, they can be destroyed by wooden stakes, clubs, etc. Vampires are not harmed by silver; silver is effective against *were-wolves*, which would be an entirely different game.

Vampires do have several weaknesses, in addition to their vulnerability to wood:

(1) They detest garlic. They cannot pass through a door festooned with garlic bulbs or plants. The GM may require real garlic, or allow a substitute.

(2) A vampire will not attack anyone who has and presents a cross. Just wearing a cross is not enough; the user must hold it out toward the vampire. If this is done, the vampire must flee. However, if the vampire has nowhere to flee, he may attack instead!

(3) Traditionally, a vampire must spend all day in his coffin, and be active only at night. To represent this, a vampire player may attack only at night, and should try to avoid daylight as much as possible. Furthermore, he must construct a dummy (use pillows, a mannequin, or whatever) and leave it *somewhere* during the daylight hours. The vampire must "visit the coffin" with the dummy once each morning (to go to bed) and once each night (to get up). If a human player can find the coffin with the vampire's "body" and drive a stake through its heart, the vampire is dead! Thus, a suspected vampire is likely to be trailed each morning and evening.

A vampire can kill a human by any "ordinary" means. A vampire may also bite a human, turning that human into a new vampire. The easiest rule is to represent a bite by a *real* bite – gentle, of course – which is why the game plays best among adults of mixed sexes. Only a privately-inflicted bite will be effective; vampires do not snatch their victims off the street and convert them in public! For game purposes, it is simplest to assume that a single bite turns a human into a vampire.

A newly-converted vampire must wear a "bite mark" (two little dots of lipstick) in the place they were bitten. The bite marks should remain visible for two days. Obviously, it is best to bite your victim in an inconspicuous place.

The human force will be safest if organized into a group of paranoid vampire-hunters under the leader-

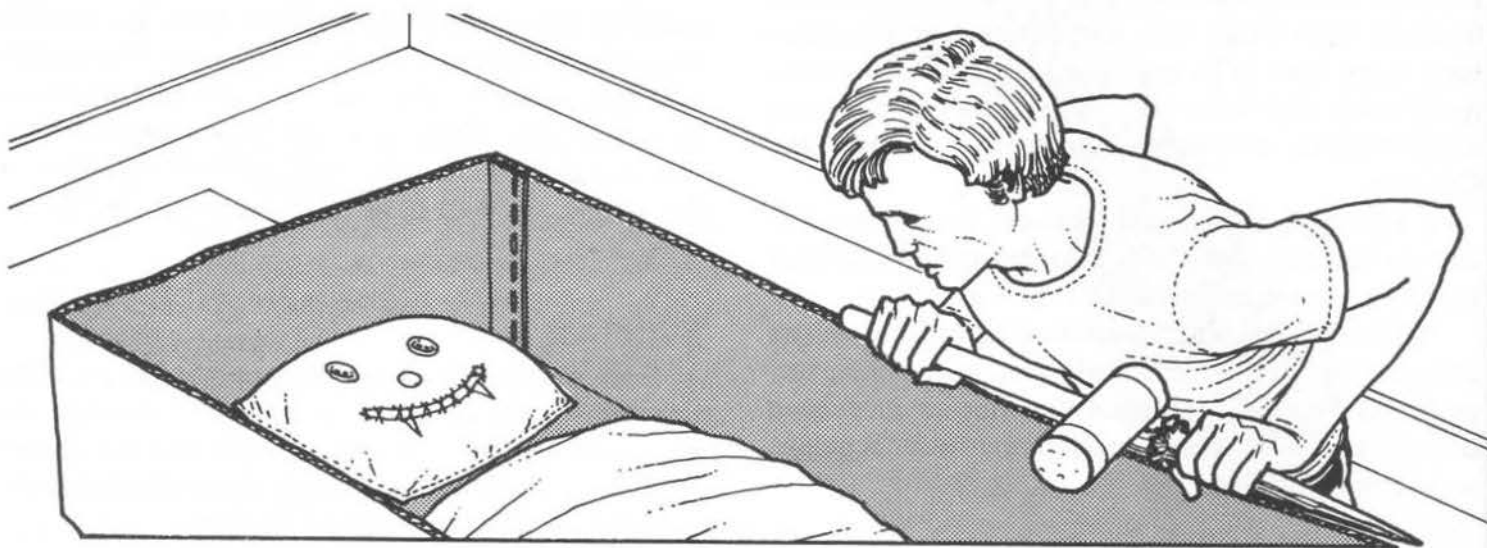

ship of someone knowledgeable in the ways of the undead, or at least in the ways of old movies. Likewise, the GM should read up on vampires in order to settle arguments and allow creative tactics by both sides.

The game ends when all the vampires are (permanently) dead, or when all humans are dead or converted. Individuals score points as follows:

For being alive (or undead) at the end of the game – 10 points

For each human in at the kill of a vampire – 10 points

For chasing a vampire away with a crucifix – 5 points

For killing a human (if you're a vampire) – 5 points

For converting a human to a vampire – 10 points

For killing a member of your own kind – -10 points

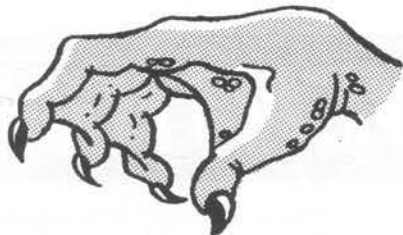

Thing From Outer Space

This scenario is unusual, in that each player has only one chance to make a successful “kill” before dropping out of the game.

At the beginning of the game, one player is the alien. He can be killed by any means that would kill a human, but he has one terrible power – the power to possess a human body. However, the alien *must* change to a new body every 24 hours, or die.

The alien player should stalk and kill one human. The alien kills by catching a human alone in a room and saying “Gotcha!” The human is allowed – nay, encouraged – to scream bloody murder, if this will alert other humans and will NOT upset non-players. If the scream brings immediate help, the alien attack fails, and the alien’s identity is known – a severe handicap!

If no help comes, the alien kill is successful. At this point, the alien leaves the old body and “possesses” its new victim. The just-killed player becomes the new alien player, with 24 hours to make a kill. The original alien, having successfully managed his kill, is out of

the game, and can sit back and watch the fun. He should immediately notify the GM of his success. After a few hours, the GM will tell everyone that the *old* player’s body was discovered . . . and the remaining humans can wonder who the *new* alien is.

Anyone in the game can be killed by regular weapons. If one human kills another, that’s too bad! If someone kills the alien, it expires in an unnatural spasm, leaking green goo, and the remaining humans have won. The alien can also use *weapons* to kill a human, but this does NOT count as a “possession.” The alien should do this only as a last resort, since it deprives the dead human of a turn as the monster. However, it’s better to kill a human than to be killed yourself!

The game ends when the alien is dead, or when the last human has been possessed (at which point the alien has built up enough life-energy to call the rest of his race from their home planet, and Earth is probably doomed).

One Killer

In this scenario, a single player represents a “mad killer.” The Mad Killer’s objective is to destroy all the other players. The rest of the players must learn the killer’s identity and kill *him*.

Only the GM knows who the killer is. The Mad Killer may use any means to eliminate his victims. Any time his identity becomes known (or suspected), the other players may use any means to destroy him.

To keep the game from degenerating into a free-for-all, anyone who kills someone, or anyone who is killed, must immediately report the fact to the GM. The GM will immediately act as judge, jury, and jailer, and enforce any necessary penalty. Penalties are as follows:

Murder (you killed the wrong person, without provable provocation): Jail – the murderer is out of the game.

Manslaughter (you killed the wrong person, but other players will testify that your victim acted in a threatening manner): Suspended sentence. You must tell the “parole officer” (the GM) all your planned movements for the rest of the game. The GM will pass this on to the Mad Killer, of course.

Assault (pulling a weapon on someone, or wounding someone, whether provoked or otherwise): Suspended sentence, as above, but for only 24 hours.

Of course, the player who successfully identifies and kills the Mad Killer is the winner! The Mad Killer wins if he gets everyone. This probably will not happen, but the more victims the Mad Killer can get, the better he is doing.

Psycho Variant

The player who kills the Mad Killer takes his place. Only the GM knows that there is new Mad Killer. The game goes on until only one player is left. The last "sane" player is free to attack the Mad Killer if he knows for sure who it is.

Detective Variant

One player, selected by the GM, is the Detective. The Detective may reveal himself to the other players, but will probably choose not to until after the first killing. Any player may carry weapons, but no one,

including the Detective, may attack except in self-defense. (Of course, the Mad Killer isn't bound by this limitation.)

If a player is attacked by the Mad Killer and survives, he should report it to the Detective immediately. A successful report of the Killer's identity should entitle the reporting player to be the next Detective, in this game or the next one.

After each murder, the Detective interviews the other players and may, if he chooses, make an accusation. If he accuses the Mad Killer, the Killer may attempt to "shoot his way out" and escape. At this point the Mad Killer becomes fair game for anyone.

If the Detective is killed, or if he accuses or shoots an innocent person, the GM appoints a new Detective from the surviving players.

The scenario ends when the Mad Killer is dead or in custody, or when he is the only player left.

KILLER AT CONVENTIONS

Killer is a favorite game at science fiction and wargame conventions. Even before the first edition of the SJ Games *Killer* rules was published, "assassination" and "Logan's Run" scenarios were common. Now, they're even more common.

That's too bad.

Killer is really not a good game for conventions. There's something about the convention atmosphere that encourages an immature, obnoxious, screaming-and-running style of play . . . not at all like the clever, classy assassinations that a real *Killer* player enjoys. Even if no one is hurt and nothing is damaged, the running and screaming annoys lots of bystanders and gives the game a bad name. So the first bit of advice on playing *Killer* at conventions is . . .

don't.

But if you absolutely *have* to play, there are ways you can go about it that will minimize the disturbance and still let you have a lot of fun.

(1) Whatever you do, do it with the full knowledge and the full blessing of the convention organizers. If they refuse to allow a game – *don't play*. There's always next week.

(2) Use absolutely nothing but Class A weapons. Better yet, confine yourself to "photo" or "sticker" kills – see below.

(3) Some conventions run an "assassination service." For a dollar, you can hire a munchkin to take out a water-gun contract on anybody you name. The money goes to the convention. That's fine, but it's not *Killer*. If that's what you want to do, it's a good idea to have color-coded stickers available at the registration desk, and forbid assassinations against anyone without a sticker. Otherwise, you can be sure that somebody is going to get very unhappy.

(4) Likewise, if you enjoy *Logan's Run* recreations, that's fine, but it's not *Killer* either. Screaming and running can be fun, but anybody who gets in other people's way or keeps them awake is an inconsiderate idiot . . .

(5) Remember: ideally, nobody but the players and the GM should even be able to tell that a game is going on, let alone who's playing, until they read about it in the program book.

Photo Kills

This is the most non-violent murder method of all. It works best in a "Circle Of Death" game. Each player is issued a photograph of his or her victim. Names are optional, but make it a lot easier! The *only* way to kill your target is to get him alone, or with the required number of witnesses, and show him the picture. That does it.

Sticker Kills

For those who want a *little* bit of excitement, but don't want to alarm the passers-by, this method is good. Each player is issued a set of small colored stickers. You attack a victim by sticking a sticker on him. Overt attacks are *forbidden* – only stealth will work. If you catch someone trying to put a sticker on you (or on a friend), you can break up the attack just by saying "I see you!" The assassin must then cease the attempt and leave the room. If it is impossible to leave right away, the killer may not make another attempt on that target until he *can* leave the room.

A sticker only counts if it is placed without the victim's knowledge. The killer can then call attention to it – or, better yet, watch until someone else points it out. He then scores points for the attack.

If you want to keep the killers' identities secret from their victims, and use the honor system to assign points, make all stickers the same. Otherwise, you can use different colors for different players, or just write your initials on them.

Different sticker locations represent different murder methods. The more difficult the location, the more prestigious the kill. A suggested scoring system:



Back, or back of collar: Knife in the back. No finesse here! 5 points.

Foot, arm or leg: Just a wound. Victim is not dead (for simplicity, wounds heal immediately). 5 points.

Hair, eyeglasses, or hat: Silenced pistol. Quiet but messy. 10 points.

On bottom of plate or drinking glass: Poison. 10 points.

Side or front of collar: Cut throat. 15 points.

Glove, wristwatch, or fingernail (good luck!): Poison needle. 15 points.

Chest: The Finger of Death. 15 points.

On his convention name tag: "Counting coup." The victim is not dead, just warned. 20 points.



THE COMPLEAT KILLER

The Perfect Murder

The perfect murder should meet a number of criteria:

(a) *Safety*. There should be no chance of actually harming the victim (or anyone else), or damaging property.

(b) *Ingenuity*. You should get your victim when he least expects it. Clever and elaborate gadgets are good – but a dart fired into his back after an especially sneaky ruse is just as surprising.

(c) *Exclusiveness*. Strange as it may seem, some people don't want to play this game, and will (quite reasonably) resent being shot by a water gun or strewn with confetti as they go about their business. *Involvement of outsiders should always be avoided – and NEVER kill anybody who isn't playing.*

(d) *Secrecy*. In the best murders, even the victim has no idea who hit him. It is almost as good if nobody but the victim knows. If you want to leave a note, that's all right . . . but the METHOD itself ought to be untraceable, and the assassin should not be killed by the victim's friends within the next few seconds!

(e) *Fairness*. The victim should always have a *chance* to escape, if he is clever, quick, or paranoid enough. A murder method that leaves the victim absolutely no chance to get away is probably not a "fair" simulation, anyway. In real life, any poison or booby trap can be detected if you look carefully; any gunman can be avoided; any pack of thugs can be outrun . . . by the right people! There should always be some loop-hole; it makes the game more sporting.

Other qualities (subtlety, horror, etc.) may be desirable in some particular game, but those listed above are basic. You won't be able to manage all of them in every kill . . . but do your best. It's much more fun that way, and more challenging, too.

Honor Among Killers

Essentially, *Killer* is a game of cowboys-and-Indians for adults. The biggest single difference is that upon hearing "Bang! I gotcha!" the *Killer* player will fall down and die, rather than replying "You missed!"

The essential element of *Killer* is cleverness and stealth (though it helps if you're a good shot). Many of the weapons used will mark the victim . . . but many will not. It is therefore essential that there be "honor among killers." Everyone in the game should understand what constitutes a "kill," and should honorably die when his number comes up. When killed by a booby-trap, for instance, you should immediately call the GM and tell him that you've bitten the dust.

If you are playing honorably, you must assume that the other players are honorable as well. Give your opponent the benefit of the doubt; if your "perfect" booby-trap didn't kill him, maybe he really didn't hear it (in which case, it wasn't much of a bomb). Each player is responsible for "counting his blows" – that is, for honorably determining when he has been hit or killed. Likewise, each player should assume that all other players are counting *their* own blows honorably. In this way, the players may slaughter each other in a mature and civilized fashion . . .

Of course, the GM is the ultimate arbiter. If he feels that someone *ought* to be dead, then they are. Ideally, it will never come to this. After all, *Killer* is supposed to be an *adult* game. If you die when you're hit, you're

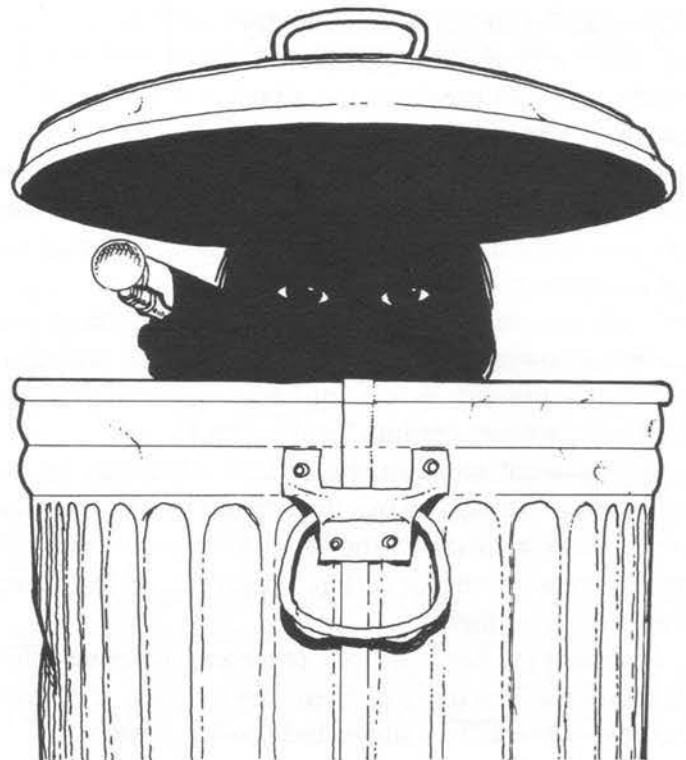

more likely to be invited to participate in the next game.

GMs may make specific rules about what constitutes a kill. Guidelines for bombs are given in the *Bombs* section; various special weapons are discussed under their specific listings. In general, when using any sort of pistol-type weapon that shoots a projectile, any hit on the victim is a kill. A hit on the clothing, boots, briefcase, etc., counts as a kill also. Exceptions: head shots may be outlawed with some weapons. Arm or leg shots are only wounds if “Wounding” rules are used – see that section.

The Etiquette Of Dying

Dying isn't so bad if you die well. Certain niceties should be observed. A dramatic death is always a good idea if there are spectators present to appreciate your acting ability (the GM may wish to give a special prize for the best death). Screaming is not always appropriate, since it may draw a little too much attention. Heroic last words are fine.

The victim should NOT discuss his death with those who did not witness it, except in general terms. In most scenarios, the identity of the killer is supposed to be secret and may affect later play.

The GM may wish to provide each player with a set of buttons or name-tags reading “Dead,” “Alive,” and (optionally) “Wounded.” The “Dead” button has an added advantage: if a non-player asks you what it means, you can tell him “It means I'm dead.” A simple pleasure, but entertaining withal.

Disguised and Concealed Weapons

A number of truly evil possibilities are open to the killer who wants to hide or disguise his implements of destruction. Some possibilities:

“Spy” toys. It is possible to find dart guns and water guns already disguised as pens, cameras, and other harmless objects. If a victim or enemy recognizes one of these things in your hand, you have “drawn” on him.

The old violin case. Any everyday object can be modified to hold a weapon. Books, briefcases, pillows, and grocery boxes are especially good.

Hide-and-fire. A step beyond the merely hidden

weapon is the weapon that may be fired without removing it from its hiding place. This requires a hole through which the gun can fire, and either an altered trigger mechanism or a larger hold for your trigger finger. Such a weapon may be fired without any tell-tale “draw” – though if your victim sees you drop into firing stance and aim a geometry text at his heart, he will be justified in going for his own weapon.

Disguised bombs. A bomb simulator may be disguised as anything. Inside the disguise, though, the bomb must have BOMB printed on it in large letters, to give the victim a fair chance. See the section on bombs for more detail.



Dirty Tricks

There is no limit to the ploys available to the clever killer. Some possibilities:

Disguise. If you don't look like yourself, it may be easier to get close to a wary victim. If you're clever enough, you may be able to impersonate a specific person. A mask will hide your identity, but will excite suspicion (see *Masks*).

Double-crossing. In a team game, you may change sides (unless the Contract specifically forbids this). If you're going to turn on your friends, make sure you get a high price – and pick your time well. The more informal the alliance, the less guilty you will feel about blowing away your buddy, and the more you need to watch your own back.

One especially fiendish double-cross involves tampering with your victim's own weapons. Poison may be placed on the mouth end of a blowgun; a water pistol may be rigged to fire backwards. Or you may simply disable your victim's weapon, so it will misfire when he uses it and (with any luck) he will be killed by the person he was attacking. This is an evil thing to do to a friend – but, as the Klingons say, you can't very well betray your *enemies*.

Ruses. If your victim is especially wary, you may be able to entice him into a vulnerable position by a faked letter, telephone call, or other communication. It is NOT legal to impersonate the GM or a police officer. Anything else (within reason) is okay.

Talking Your Way Out Of Trouble

In a situation where you are confronted by one or more killers and have no weapon . . . use your wits. Depending on the scenario, you may be able to convince them that it is to their advantage to let you live, or even that you're really on their side. It is *not* legal to tell them that you've dropped out of the game (or that you were never playing), that you're already dead, or that the rules have been changed so that they may no longer attack you. Anything else you can convince them of is perfectly all right.

Anti-Infiltration Tactics

If you suspect that your enemies have access to your living quarters, you may wish to take certain precautions to lengthen your life. Some possibilities:

Accomplice observers. If accomplices are legal, let your neighbors know that someone is (figuratively) after you. *Make sure they understand that it's only a game, so assassins don't find themselves facing a genuine shotgun!* A true assassin's target would want to surround himself with friendly eyes; you can do the same.

Intruder alerts. Small pieces of string and paper may be strategically arranged around your door and elsewhere. If they're disturbed when you return, then you know to look out for booby-traps, ambushes, and poison. The old James Bond "hair across the hinge" is good, too.

Alarms. If you suspect you may be murdered in your sleep, setting some sort of makeshift alarm at your door is a good idea.

Camera trap. If you arrange a gadget that *photographs* intruders, you can find out who your assassin is . . . and go after HIM.

Preemptive booby-traps. Arranging a trap (or poison) in your own living quarters, in order to kill intruders, has its merits. It also has its risks. A killer who does this carelessly may quite literally be hoist by his

own petard. The GM might assess a point penalty for this (except for "Stupid" characters, who would probably get a bonus).

Restrictions

Players may wish to impose added restrictions on themselves, in any scenario . . . either to make the game more challenging, or to keep it from taking up too much time. Some ideas:

Limit each killer to one attack per day. Only one attack (no matter what the type) can be made each day. Whether it fails or not, the assassin then cannot try to kill anyone else until the next day – except in self-defense, of course. Setting a bomb, poison booby-trap, etc., counts as an attack on the day it is arranged, regardless of when (if ever) it is found or tripped.

No murder method may be repeated. You may say that no killer may try the same attack twice on the same victim . . . or that no killer may repeat the same method twice on ANYBODY. This quickly forces players to evolve some new and interesting techniques for extermination. The GM is the final judge of what is "new." A player eliminated by an old method should be brought back to life, though he may be docked points for getting caught napping.

Tighten the "witness" restrictions. You could, for instance, require a maximum of two witnesses, and prohibit masks entirely. This would mean that there would be relative safety in numbers, and force killers to rely more on traps and ploys and less on speed and surprise.

Death Certificates

The GM may require that each player carry a blank "death certificate" at all times, to be properly filled out and given to any successful assassin. This is best in individual (as opposed to team) games. Two sample death certificates are on p. 62; these may be photocopied for use by players. The death certificate has spaces for the victim's name, assassin's name, place, time, method of execution, and the signatures of up to three witnesses to verify that the murder was done in a legal and proper fashion. A death certificate makes a good souvenir, and may also be used by the GM in keeping track of points and writing the "news items" for the bulletin board.

Mission Cards

In a "Circle Of Death" game where players do not all know each other, the GM may make up "mission cards" for each person. Before the game, photos of all participants are taken. Each photo is attached to a card, along with that person's name and other information the GM sees fit to include. The card for each victim is given to his assassin. Keep your card on your person at all times. When you kill your victim, you take *his* mission card to find your new victim. If you are killed, you should ask the assassin to show you the card with your name on it – if he can't do so, he was not your assigned assassin!

Legal Matters

Players of *Killer* are strongly encouraged to exercise common sense during the course of the game. This

game allows any number of opportunities to get in trouble if you're not careful. If you are skulking in the bushes outside a dormitory at two in the morning – or if you pull a realistic-looking gun in a public building – you may have more problems than you bargained for. Let's not mince words . . . you could be *shot*. For real. It's happened – though never to anybody who was using this rulebook. One of the big reasons for publishing this book was to warn would-be players what can happen if they don't use common sense.

Even if you don't get shot, foolish behavior can get you arrested. By playing assassination-type games without thinking, one may find oneself charged with (among other things) assault, assault and battery, kidnapping, vandalism, breach of the peace, breach of curfew, trespassing, impersonating a police officer, malicious mischief, arson, and quite possibly moper, dobery, barratry, public intoxication, and/or insanity. Keep this in mind. Stay out of trouble – and if you get arrested while doing something you shouldn't, please do not call the author and ask for bail.



OTHER REAL-LIFE SIMULATIONS

Killer is intended as a game of stalking and assassination . . . to be played as the participants continue their everyday activities. It is therefore necessary to take *every safety precaution imaginable* – which rules out a number of interesting and realistic types of weapon simulation.

Several re-creation groups around the country engage in mock battles and wars set in various historical periods. If you're interested in military maneuvers rather than civilian stalk-and-kill games, you might investigate these groups. Please note that these groups have not endorsed the game *Killer*, or vice versa! This information is provided only as a service to the reader.

Medieval Period

The Society for Creative Anachronism, the Markland Medieval Militia, and other groups simulate warfare of the Middle Ages, wearing authentic-styled

leather, chain, or plate armor and fighting with simulated weapons made of padded rattan. This is a true martial art; strength, prowess, and reflexes are required, as is a certain ability to withstand pain. The techniques used would be totally out of place in a game of *Killer*, but can be safe when practiced (as these groups do) under the eyes of trained marshals and medics. Both one-on-one tourney combat and mass "wars" are fought.

Revolutionary and Civil Wars

Various groups around the U.S. stage regular re-creations of famous battles. As a rule, the uniforms and equipment used by these groups are totally accurate, save that no bullets are fired. Results of combats are usually pre-arranged; these battles are dramatic presentations rather than contests.

WWII and Modern Period

Some re-creational groups of the type described above are now performing WWII battle simulations, complete with authentic tanks and other equipment. They use blank ammunition only. Some battles are at least partially competitive, scored by umpires; others are dramatic presentations for audiences.

Paint-gun combat is an increasingly popular hobby. It started with the "National Survival Game," founded in 1981. Participants pay a fee (usually between \$10 and \$20) for a two- to three-hour wilderness stalk, playing a version of Capture the Flag while armed with guns that shoot paint pellets. Goggles and protective gear are necessary – the pellets sting, and leave bruises if fired at close range.

A huge variety of equipment is now available, especially customized weapons (including automatics!), paint grenades, and the like. Some devotees establish permanent teams and join leagues – or sign up for all-day battles in remote areas. This is about as close to "real" war as you will ever get without having anyone really try to kill you.

This sport has become popular enough that there are whole magazines devoted to it – so for more information you need look no farther than the nearest large bookstore.

Similarly, there are groups of "B-B Gun Warriors" who practice authentic battle tactics in competitive fashion, armed with light B-B guns and dressed in heavy clothing with face protection. Again, this sort of gear would be totally unsafe for a *Killer* game. Played in the country, under proper supervision, it still has hazards, but at least does not endanger bystanders.

Future and Fantasy

Various science fiction and fantasy fans around the country sponsor events, especially at s-f conventions. One common type of live re-creation is the "Run," based on the book and film *Logan's Run*. A group of costumed Hunters pursues a group of costumed Runners through halls and down streets, waving mock zap-guns. Rarely are there any specific rules; the chase is the object, not capture or escape. Combat scenes from other stories or shows are often acted out in guerilla theater fashion.

A high-tech stalking game is "Photon." A group of players spend a long six minutes hunting each other through a dimly-lit multi-level fantasy world . . . with *ray guns*. Each player wears an LED-studded harness and helmet, and carries a computer-controlled "gun" that automatically scores your kills and turns a foe's weaponry off when you hit him! Photon was founded in 1984, and was very popular for a while, until toy versions of their equipment became available in stores. As of this writing, we don't know whether there are any Photon locations still open.

And many groups are experimenting with different sorts of "live-action roleplaying" (LARP for short), usually in a fantasy setting. Most LARP games are like standard fantasy roleplaying adventures. The players costume themselves and walk through a scenario, interacting with "non-player characters" who may be umpires, employees or just volunteers. The main objective is to find a treasure or to solve a puzzle or mystery, but combat – generally with boffers and stylized "magic" – can break out either between players or between the party and the NPCs. LARP is most popular in the U.K., but is gaining a following in the United States.



a scholar looks at *KILLER*

The present volume represents the first publication of its kind. It is, as it were, a “codification” of an orally transmitted folk game which has been diffusing from one university campus to another for the past 15 years. Since it has existed heretofore only in the oral tradition, a number of variants have evolved (see *Scenarios*, p. 41). This fact of variation in an unstandardized manner, together with the fact that a specific group (namely students) has played the game over the years, interests folklorists very much. Folklore, whether oral, gestural, material, customary, or in any combination of these, can often be isolated from other forms of human behavior by locating its multiple forms, and the game of *Killer* (K.A.O.S.*, Assassination, Ping Pong Murder, etc.) is a prime example of this theoretical definition of folklore. Moreover, many folklorists today accept the theory that any group which identifies itself as a group and which practices varieties of tradition can legitimately constitute a “folk.”

Folklore is often the source of ideas for more standardized forms of creative behavior, and here again the game of *Killer* is a prime example. This book, for instance, is not folklore, as it will have, by its very nature as printed data, a standardized influence on the game by codifying the rules. Henry II accomplished the same feat by sending his judges into the English countryside to record and codify the English “common law.”

Conversely, more standardized forms of creative behavior often are the source of ideas which move into the oral tradition, and become forms of folklore. Again, *Killer* exemplifies this process. Indeed, the entire history of this game has seen ideas pass from unstandardized tradition to standardized creative behavior several times.

The basic idea behind this game is that of a hunt where the victim is human. The human hunt motif has

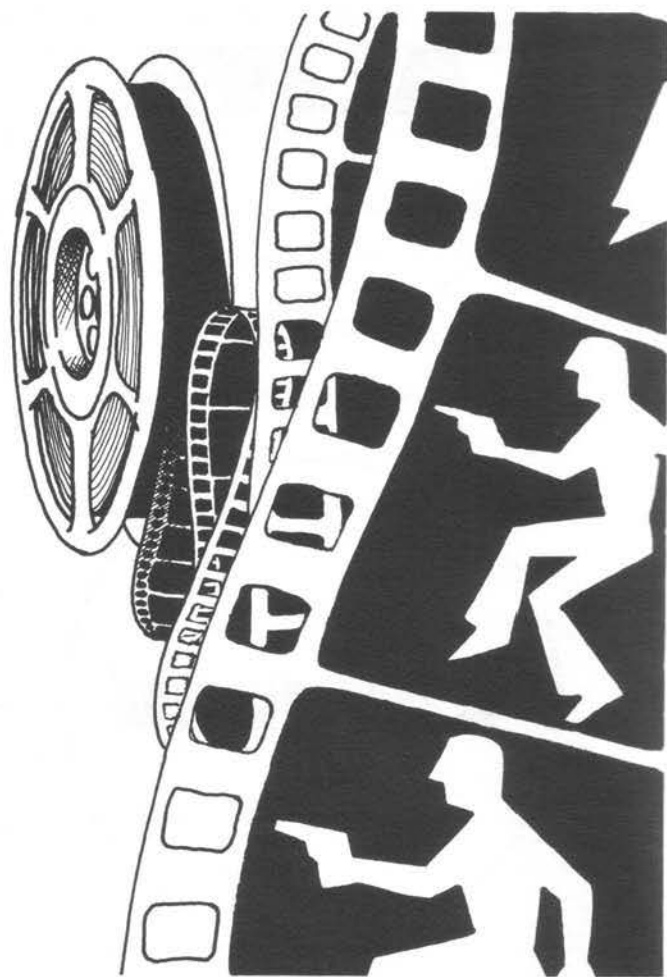

passed back and forth from oral to written tradition many times. One of the most famous examples in literature is Richard Edward Connell’s 19th-century short story, “The Most Dangerous Game.” One of the most famous examples in oral tradition is found on the Isle of Man where, in one (non-lethal) variation of the English fox hunt, a person is substituted for the fox. Recent examples also exist, from human hunt versions on television (*Gilligan’s Island*, *The Six Million Dollar Man*, *The Avengers*, *The Incredible Hulk*) to the same in films . . . and this brings us to the origin of *Killer*.

The ideas upon which *Killer* is based began in a short story by the noted science fiction author Robert Sheckley. Sheckley published his story, “The Seventh Victim,” in *Galaxy Magazine*, Vol. 6, No. 1, in April of 1953. It was made into a radio play and aired on NBC

* “Killing As an Organized Sport”



The purchaser of this book is welcome to copy these button masters for use in his own games.

Radio's weekly program "X Minus One" sometime before the mid-1960s. The Italian producer Carlo Ponti bought the film rights to Sheckley's short story, hired a staff of writers, and converted the story into a feature-length film, *The 10th Victim*, starring Marcello Mastroianni and Ursula Andress. The film was released in December of 1965, and was seen all over the country in a matter of months. It was at this juncture in time that the human hunt game spread from cinema to oral tradition. I remember when the first games were played in 1966 on the campus of The University of Texas at Austin. The game in the oral tradition thus has no single origin, as the multiple copies of the film played in hundreds of theaters all across the country at the same time. At least two universities, however, have become real focal areas and diffusion centers of the game, to wit, the University of Michigan at Ann Arbor and the University of Florida at Gainesville.

When it began, the players of the game were inspired by the film. Now, fifteen years later, the players do not know anything about its origins. I have interviewed over 200 players, mostly by written questionnaires, and only one game organizer had ever heard of the film. Today's players were three and four years old when the film was making its rounds in American theaters. Thus, the game exists today wholly in the oral tradition.

Recently the press has begun to add its power to the diffusion process of *Killer*. People all over the country have read about it in newspapers and magazines, and the game has spread to high schools. One attempt to sell it to the general public on the computer dating model in Miami, Florida, apparently failed, and the "folk" of the game today remains the student. Perhaps the identification of the game by the press as the "latest college fad" was what interested two film companies, and the films entitled "T.A.G. (The Assassination Game)," and "K.A.O.S." are presently being shot.

So now the game has gone full circle, from literary origin in Sheckley's short story, to the cinema in Ponti's film, to the oral tradition on campuses, and back to the cinema. And now . . . to the rule book! Who knows what will happen next? Perhaps as a result of this book, *Killer* will spread even farther.

— John William Johnson
Assistant Professor of Folklore
Indiana University
17 June, 1981



CONTRACT

Witnessed and agreed, heretofore, that certain parties named and unnamed do hereby mutually agree and consent, *ipse dixit, habeas corpus, ad valorem, quid pro quo*, etc., to wipe each other out, as follows:

Scenario and/or type of game: _____ Roleplaying rules? _____

GM(s): name, address, phone number, and times when contact is allowed: _____

Location of game bulletin board: _____

Allowable weapons: _____ Will GM OK other weapons? _____

Game boundaries: _____

Off-limits areas: _____

Starting and ending dates of game: _____ Hours of play: _____

Witness requirements or limitations: _____

Are wounding rules being used? _____ Lives per player: _____

Is money being used: (If so, attach weapon price list.) _____

Are identities of players secret? (If not, attach list of players.) _____

Are accomplices legal? _____ Is recruitment legal? _____

If victory point schedule differs from that given for this scenario in the *Killer* book, specify. _____

If any special rules are being used, list them. _____

KILLER[®]

The purchaser of this book is welcome to copy this form for his own use.

Death Certificate

To whom all these presents may come: Be it known that

_____ was eliminated in a lawful and
approved manner by _____

at the following time and location:

in the following manner:

Witnesses:

For the Committee:

Death Certificate

To whom all these presents may come: Be it known that

_____ was eliminated in a lawful and
approved manner by _____

at the following time and location:

in the following manner:

Witnesses:

For the Committee:

The purchaser of this book is welcome to copy these certificates for his own use.



WEAPON TABLE

This table shows the cost of each weapon if money is being used, and the effect of each weapon if wounding rules are being used. To determine the effect of a weapon, roll a six-sided die. A "K" is a kill, a "W" is a wound, and an "M" is a miss. This may be done in either of two ways: If both players are present (e.g., a knife attack) then they can roll for the result immediately. No hostilities are allowed after the initial attack, until five minutes after the die roll. Alternatively, the victim can phone the GM and have the GM roll for him. Thus, the attacker will not know whether he scored a clean kill!

Weapon prices include a lifetime supply of ammunition. Poison prices are cost per individual dose.

Primitive Weapons

Ape\$400 1-4K; 5-6W
Blowgun w/ poison\$50 1-4K; 5-6M
Boiling oil\$5 1-4K; 5-6W
Bow and arrow\$50 1-3K; 4-5W, 6M
Club, ax, sword, etc.\$40 1-5K; 6M
Firefree 1-5K; 6M
Garrote\$5 1-5K; 6W
Heavy dropped objectfree 1-4K; 5W; 6M
Knife\$5 1-2K; 3-5W; 6M
Petard\$100 1-4K; 5-6W
1 Piranha in <i>tank</i>\$30 1-4W; 5-6M
10 Piranha in <i>pool</i>\$300 1-3K; 4-5W; 6M
Pit w/ spikes\$10 for spikes 1-3K; 4-6W
Rolled sock blackjack\$10 1-3K; 4-6W
Slingshot\$20 1-2K; 3-4W; 5-6M
Snake\$30 1-3K; 4W; 5-6M
Spear\$25 1-4K; 5W; 6M
Spider\$15 1K; 2-5W; 6M
Staircase tripperfree 1-2K; 3-5W; 6M
Throwing star\$10 1-2K; 3-5W; 6M

Modern Weapons

Electrocutionfree 1-5K; 6W
Flamethrower\$500 1-4K; 5-6W
Grenade\$50 1-4K; 5W; 6M**
Machine gun\$500**
Pistol\$100*
Rifle\$250**

Rocket launcher, etc. . . . \$500 as for grenade

Bombs

Letter-bomb\$50 1-3K; 4-6W
Small bomb (clock)\$100 †
Med. bomb (shoe box)\$250 †
Large bomb (crate)\$600 †

Poison

Contact poison\$100 1-4K; 5W; 6M
Food/drink poison\$20 1-3K; 4-5W; 6M
Gaseous poison\$100 1-4K; 5-6W
Weapon poison\$30 1-2K; 3-4W; 5-6M
Envelope toxin\$50 1-3K; 4W; 5-6M
Kiss of Death as for contact poison
Nail of Death as for weapon poison
Poisoned shower as for food/drink poison
Toilet tank trap as for gaseous poison

Futuristic Weapons

Aerosol virus\$500 1-5K; 6W
Bladeless knife\$100 1-4K; 5-6W
Capacitor zapper\$200 1-4K; 5-6W
Clone\$200 1-4K; 5-6W
Deadly envelope\$300 1-4K; 5-6W
Laser gun\$600 *
Radioactive poisoning\$300/cylinder ***
Robot killer\$300 1-5K; 6W
Shields\$500 apiece defensive
Sonic pulse device\$500 1-3K; 4-5W; 6M
Teleport gate\$600 automatic kill
Umbrella gun\$500 **
Umbrella shield\$500 defensive

Exotic Murders

GM's discretion – for those listed *and* anything else the players can dream up!

* A pistol is an automatic kill if it hits on the head or body. If it hits on a limb, or on something carried by the victim, it is an automatic wound. If the pistol is of a type that does not mark the victim (e.g., cap pistol), it is 1-4K; 5W; 6M.

** These weapons always kill with a direct hit. The

values given for grenades are to be used if the grenade splashes (but does not strike) the target.

*** Use the rules given for the radioactive poisoning method. If the cylinders are discovered before the victim dies (actually, lapses into coma), he can seek treatment and there will be no "W" result.

† The effect of a bomb depends on its size, as described in the rules. The sizes given in the table are examples. A car bomb, for instance, would have a "medium" effect if it was represented by a shoe box, or anything of a similar size.

The radius of effect of a bomb, as given in the rules, is its wounding zone. Anyone in this radius has a 1-3 chance of being killed, and a 4-6 chance of being wounded. Anyone touching a "medium" bomb when it goes off, or in the same room with a "large" bomb, is automatically dead.

Futuristic bombs cost four times as much as their modern counterparts, but inflict as much damage as the next bomb size up.

INDEX

Accomplices, 6, 15
Animals, 15, 38, 39.
Automobile bombs, 29.
Axes, 14.
Bananas, 18.
Blowguns, 13.
Boffers, 14.
Bomb squad, 30.
Bombs, 16, 22-30, 39, 45, 63, 64.
Booby traps, 25.
Bows, 13.
Bulletin Board, 3.
Buttons, 9, 60.
Bystanders, 7.
Clubs, 14.
Contract, 3, 61.
Conventions, 52-53.
Counter-assassination, 7.
Curses, 37.
Dart guns, 18.
Death certificates, 56, 62.
Death, *accidental*, 7.
Defense, 7.
Dropped objects, 16.
Dropping out, 5.
Drowning, 40.
Duels, 9.
Electrocution, 22.
Ending the game, 4.
Etiquette, 55.
Falling, 16, 40.
Fantasy, 37-39, 50.
Fire, 17.

Flamethrowers, 21.
Foucault pendulum, 24.
Garrotes, 14.
GMs, 3-11, 54.
Godfather, 47.
Grenades, 20.
Group attacks, 40.
Idiots, 3, 11.
Knives, 13.
Legal matters, 2, 57.



Live-action roleplaying, 58.
Machine-guns, 20.
Masks, 8.
Money, 9.
Murders, *exotic*, 11, 38.
Off-limits, 5.
Paint guns, 19, 58.
Perfect murder, 54.
Photo kills, 53.
Pistols, 17.

Point systems, 10, 48.
Poisons, 31-34, 39, 63.
Primitive weapons, 13-17, 63.
Real-life simulations, 57-58.
Recruitment, 6.
Remote control, 29-30.
Rifles, 20.
Rocket launchers, 22.
Roleplaying, 10.
Rubber band guns, 19.
Scenarios, 41.
Science fiction, 34, 51.
Secrecy, 6
Self-destruction, 5, 7.
Slingshots, 16.
Snakes, 15.
Society for Creative Anacronism, 57.
Spears, 14.
Spiders, 15.
Sticker kills, 53.
Targets, *legitimate*, 6.
Time bombs, 23.
Time limits, 5.
Vampires, 50.
Water weapons, 17, 20, 21, 22.
Weapons, 12; *approval*, 12; *classes*, 12; *futuristic*, 34-37, 63; *modern*, 17-22, 63; *primitive*, 13-17, 63; *table*, 63-64.
Witnesses, 9.
Wounding, 8-9, 63-64.
Zen Killer, 11.

WATCH YOUR BACK!



You might be . . .

- ◆ Bitten by rubber snakes!
- ◆ Bombed with pillows!
- ◆ Poisoned with peanuts!
- ◆ Shot with a banana!
- ◆ Electrocuted by ropes!
- ◆ Hosed & sprinkled, squirted & boffed . . . even ping-ponged!

Killer is the exciting *live* roleplaying game for intelligent, creative and slightly uncivilized people – people who want to knock off their friends . . . without hurting them.

In this unique game, each player becomes an assassin, stalking one (or all) of the other players. Squirt guns replace pistols; water balloons become bombs . . . whatever your fiendish mind can devise. As the assassins take out their targets, the number of players dwindles. The last one alive is the winner.

Besides the basic game, there are 16 different advanced scenarios . . . games that set the players up as everything from 1920s mobsters to modern-day vampire hunters. You can play *Killer* in any background you can imagine.

Also included in this new, expanded version are hundreds of gadgets, strategies for devious ways of bumping off your friends, safety tips and more.



Written by Steve Jackson
Illustrated by Denis Loubet
Cover by Carl Anderson



ISBN 1-55634-253-5

SJG01295 1201

Made in U.S.A.

STEVE JACKSON GAMES