

MAD MASK SPIRE

FIVE CATACLYSMS

Nickolas Z Brown

Mad Mask Spire

The Spire has stood as a bastion of evil for centuries, and now under the rulership of the dread witch, Hagatha, the evil blossoms anew. Over the years, many noble heroes have found their minds twisted by the evil here, drawn in by their lust for dark power. Will the heroes of today fare any better?

This dungeon is ideal for a secondary adventure, only to be embarked on once the group has some victories under their belt. The difficulty here can ramp up very quickly if poor decisions are made. There are some things about the dungeon you should be aware of:

Note Doors: Many of the doors here are magical stone doors with musical notes upon them. They can most easily be opened by using the flute in the Sound Parlor.

Face-Chest Brutes: The most common enemy in the dungeon is the idiotic, brutish, and sometimes friendly Face-Chesty. They are muscular green humanoids whose face is in their chest, as they have no heads. Hagatha has them in abundance, and uses them to carry out simple tasks, but they are susceptible to bribery or confusion. If the face-chesties get confused by adventurers, there's a probability that they will approach the nearest Boss for help sorting out the situation. Although they can be bribed, they will always be loyal to Hagatha so long as they can receive her orders.

Bosses: There are many sub-bosses in this dungeon. Vat-Master Vryguld manages the vats in room 10, where potent materials are kept fresh. Blueman Bekemi in room 17 oversees the testing of new alchemical mixtures upon innocent captives. Brewmaster Higamok of room 19 brews the potions used in the tower. Darklord Mendacious uses various materials to assemble necromantic horrors in his workshop in room 28. Angrash the Blood Dipper oversees bloody sacrifices and maintains the tower's supply of blood in room 36. Finally there's Hagatha who oversees the Tower's Operation from her private quarters on Floor 5.

Black Market: This dungeon contains a Black Market where evil creatures sell questionable goods. Feel free to stock it with new items as they are bought up. The entities of the black market pay Hagatha in order to operate in Mad Mask Spire. The Black Market is an independent entity which will continue to operate with or without Hagatha.

Hagatha War Tactics: Once enough damage has been done to the spire, Hagatha may begin striking out from her tower. She has access to powerful rituals and spells that allow her to fling magic great distances. She can send out expeditions to lay ambushes for adventurers, or even hire mercenaries to kill the adventurers in their sleep. The only way to defeat Hagatha is to find and destroy her Magic Jar, where her soul is stored.

Music suggestions - *For spookier areas, Binding of Isaac - Womb theme. I also enjoyed using music from Gruntilda's Lair. For the Black Market, I used Black Market music from Spelunky.*

Possible Lead-In Quests

There's a lot of evil in the tower that could prompt a quest. Young women are sold in a shop in the Black Market. Children are captured and turned into food. Perhaps the brain of an important individual was placed into the 'Thinktank' in room 59. Perhaps someone's loved one became a test subject in room 17. In any case, most human civilizations would pay handsomely for the destruction of this bastion of evil.

HOW TO USE THIS KEY

Preparation: Be sure to read the primers on the previous page to get a feel of how the dungeon operates!

Room Keys: Any text not italicized or (parenthesized) may be read aloud to the players. (Parenthesized text is for DM eyes only, typically explaining an unseen item or function.) **Bold** text will refer to deeper explanations provided outside of this paragraph, for example:

Bold – (The bolded item would be described here.)

In addition, you may use the ctrl-f feature to find any room by typing the room # and a ‘:’ such as ‘05:’

Monster Keys: Listed within each room key, and codified as per the terms below:

HD – Hit dice. Determines attack bonus, hp, and saving throw. For example, an HD3+2 Monster has (3d6+2) hit points; +3 to attack rolls, and a saving throw of (18-3=15).

Hp – A creature with an Hp value has a set Hp total, and an attack bonus of 0 unless otherwise specified.

AC – Armor Class. Attacks must match or exceed this value to hit. Monster touch AC is reliant upon AC source. Armored targets have touch AC of 10, but a dodgy bat with an AC of 14 will have touch AC of 14.

SPD – Indicates the Speed of the creature. If not listed, assume speed is 12. 12 is considered unencumbered.

ATT# - The number of attack rolls a creature may make.

Xtra1dmg – Deals one extra damage on attack.
“SvSpells” Means “Save versus spells”

CONVERSION FOR OTHER SYSTEMS

If you’re not using the Five Cataclysms rule set, that’s fine. The module works well with any od&d or whitebox editions, and should work for the most part with d&d 5e. All HD values are d6, but you may change these as you see fit. All AC values match the creatures thematically, so you may adjust them accordingly.

Armor Class is Ascending

Armor Class starts at 10 (typically)

Attack Bonus = Monster HD

Save = 18 minus Monster HD

Speed of 12 is Human Average

Morale Checks are rolled using 2d6; rolling above 6 means failure.

A Turn is about 10 minutes, a combat round is anywhere between 10 seconds and 1 minute.

Always remember that as a Dungeon Master you have the power to change whatever you want; the contents of this module are merely suggestions. If a combat is too easy/hard for your liking, tweak it. Have an idea that’ll make a room even more fun? Put it in! Do whatever you need for you and your players to have fun!

EXP HOW

This module is designed for a treasure-as-exp system. EXP is rewarded 1 point per each gold-piece worth of treasure extracted from the dungeon. This way, avoiding or tricking monsters is just as viable as murdering them.

For any feedback, please send an email to FiveCataclysms@gmail.com We’d love to hear from you!

WANDERING MONSTERS

- For wandering monster checks, roll a d12 every turn (or ten minutes). On a result of 1, roll on the table to determine what monster appears. If no monster appears or the 1 is not rolled, increase the threshold for the d12 from 1 to 2, making wandering monsters more likely to appear as time passes.

- Be sure to reduce the population counter on the right as monsters are destroyed.

If an entire population is slain, remove that monster from the list. If subsequent checks roll an empty result, no monster shows up.

- **High alert:** If a group of monsters manages to flee the party, they will put the dungeon on High Alert which means a d8 will be rolled for wandering monster checks instead of a d12.

d10	# of Enemies that Appear	Monster Description	Population
1	1d4+1 Chest-Face Brutes	CHEST-FACE BRUTE – <i>Green, muscular, and headless, as their face is actually in their chest. Very stupid, potentially friendly, easily distracted with food or logic loops. Hagatha is their ‘Mother’</i> HD4+4 AC12 xtra1Dmg Food Weakness: If offered food or they see thrown food, they must SvParalysis or pursue the food, forgetting about combat. Mother’s Instruction: If the Face-Chesties get confused by invaders, there is a chance (morale) they will simply drag the adventurers to the nearest ‘boss’ for them to figure out the situation.	20 remain
2	2d6 Fat Flying Imps	FAT FLYING IMP – <i>It pants and heaves as it flaps its wings frantically, barely staying afloat. Attacks with its sharp tail.</i> HD1 AC13 SPD9Flying	30 remain
3	3d6 Giant Flying Krill	GIANT FLYING KRILL – <i>It’s sky shrimp! With bee wings!</i> HD1 AC13 ATT#4	72 remain
4	1d4+1 Leper Dwarves	LEPER DWARF – <i>A leprous small person in armor. They want to share their blessing.</i> HD2+2 AC16 Targets hit must SvPoison or be inflicted with the disease leprosy, which reduces every stat by 1 per month.	15 remain
5	3d4 Angry Masks	ANGRY MASK – <i>A montage of strange masks, all furious, many with blood dripping from their eyes...</i> HD1+1 AC14 SPD12Flying Instead of dealing damage, Targets hit must SvSpells or become possessed by the mask until the mask is destroyed. The character will attack their former allies. Damage done to a worn mask is also inflicted upon the wearer. <i>If a person is still possessed when the adventurers are killed off or flee, that person shall become a wandering monster that accompanies the Angry Masks.</i>	20 remain.
6	The Bloodmyst	BLOODMYST – <i>A terrifying cloud of red mist that billows about, draining the blood from those caught within.</i> HD10(Hp40) SPD6 *Only damaged by area-of-effect attacks such as firebombs or fireballs. Attacks by encompassing an area; all creatures with blood within will be drained of 1d6 hit points, which adds to the Bloodmyst’s total. The bloodmyst’s total size in square feet is equal to its current Hp divided by 4. <i>God forbid it find the blood-vats, or it will grow to terrifying size.</i>	Only the one.
7	1d4 Flying Brains	FLYING BRAIN – <i>Still dripping blood, but magicked and mutated.</i> HD1 AC18 Attacks by projecting a psychic effect: Target must SvParalysis, or take 1d6 damage and be stunned 1d6 rounds.	20 remain
8	1d3 Swamp Crocodiles	SWAMP CROCODILE – <i>Has an adorable over-bite!</i> HD3+3 AC12 ATT#2 May Grapple on hit in order to hit automatically the next round. Will disengage if it can drag away a kill. May be dissuaded with meat.	Endless until room 5 portal closed.
9	2d6 Ferocious Fungi	FEROCIOUS FUNGI – <i>They’re noisy, they’re angry, they’ll surprise nothing. Too angry to flee.</i> HD1 AC10 SPD6 50% have poisonous attacks: SvPoison, or suffer additional 1d6 damage for 1d3 rounds.	48 remain
10	2d10 Headless Zombie	HEADLESS ZOMBIE – <i>It’s got an antennae sticking out of its neck-hole! Gross.</i> HD1 AC10 Perfect Morale	50 remain

Map of Mad Mask Spire

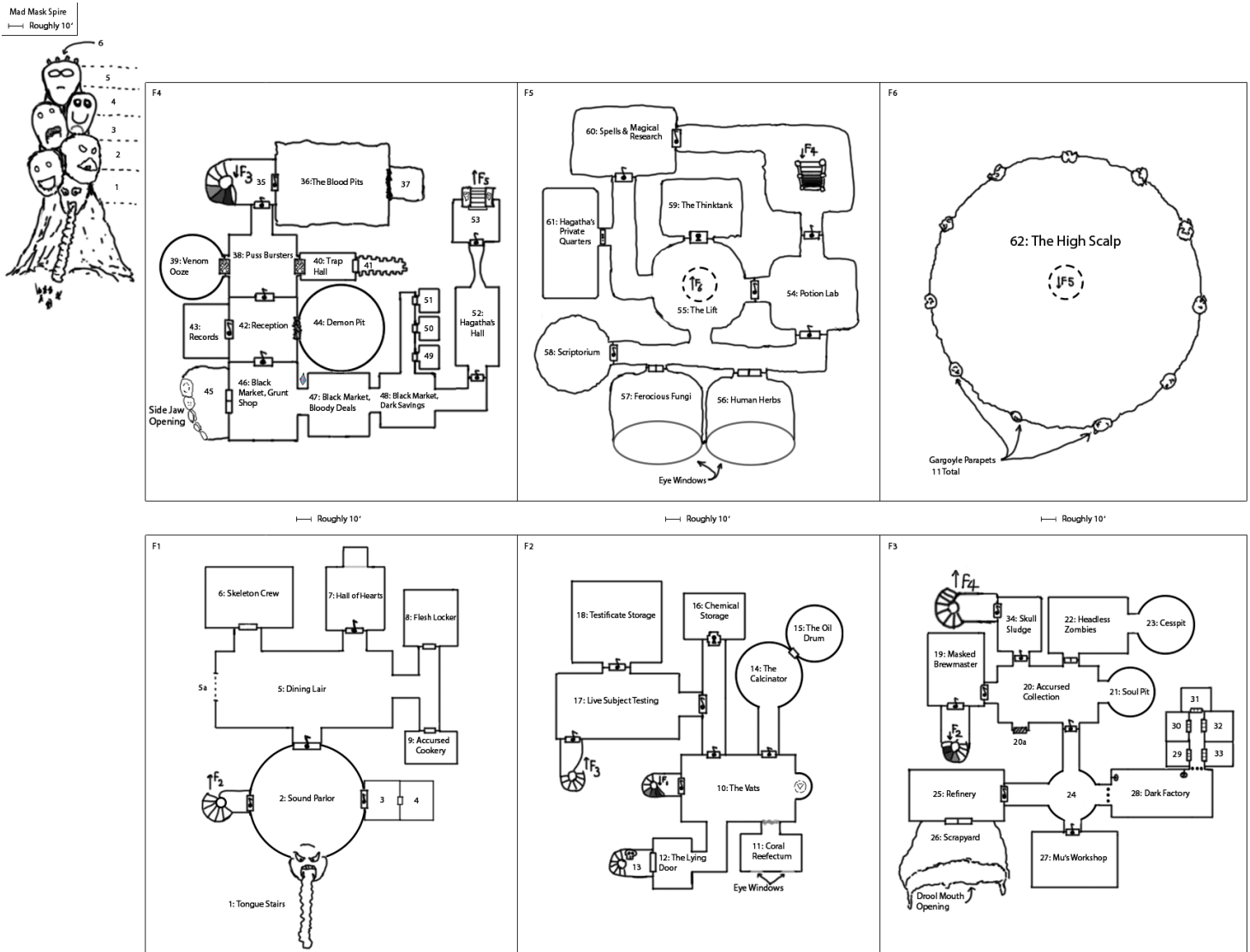

The upper left has a diagram of the locations of the spire's floors, roughly. The thickness of the walls in any given area can be between 5 and 20 feet; use best judgment.

There are 4 points of ingress: The tongue stairs at the bottom, the 'Drool Mouth Opening', the 'Side Jaw Opening', and the lift upon the 'High Scalp'.

Floor 1

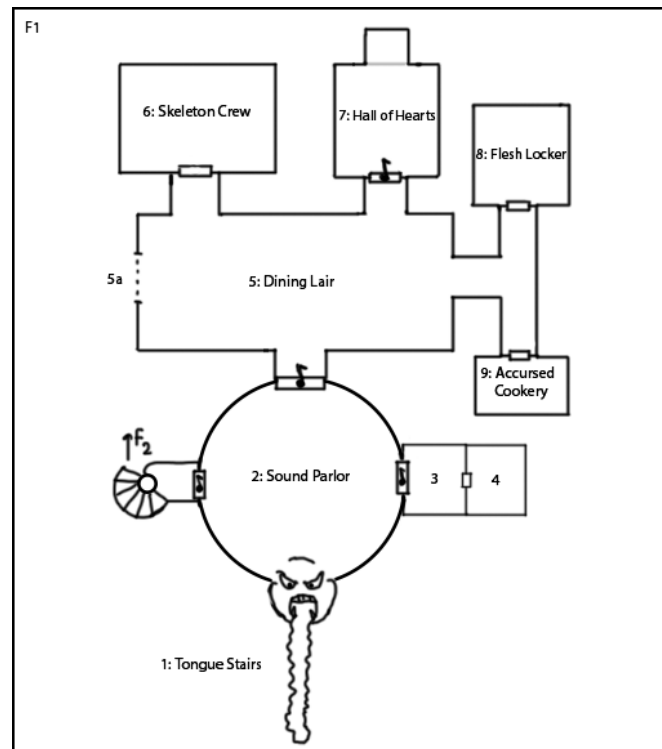
**01: Tongue Stairs**

A slimy tongue forms **stairs** that descend from a vile face with sharp teeth. Its **mouth** appears to be an opening into the spire.

Stairs – (These stairs are climbable, but narrow such that those climbing must go single file. Larger creatures such as bears may ascend the tongue, but they’ll risk falling during combat.)

Mouth – (Only 4 adventurers allowed inside! After 4 humanoids pass into the mouth, the tongue will straighten into a ramp, causing extra people to slide down to the bottom. The 5th person in line may SvBurst to grab onto the ledge of the mouth, but as soon as they try passing through the teeth, the teeth will slam down on that person. The **Vile Face** can be beat into submission from inside or outside, but it will defend itself by forming its tongue into a sharp spike.)

VILE FACE – *It has a sinister look in its eyes, which are focused on the figures upon its tongue. It is eager to kill, once the condition is met...*

HD10+10 AC15 ATT#3

Tongue Stab - Forms tongue into a sharp spike and attacks targets at range. Deals 1d6+1dmg.

Tongue Toss - If the Vile Face is attacked from within, it will attempt to grapple a person using its tongue, and throw them out the entrance, such that they may fall to their death. They will fall about 60’, taking 6d6 fall damage.

Teeth Attack - Can only target those attempting to pass through the teeth. Deals 3d6 dmg.

Regeneration - Face will regenerate within 24 hours, growing back from the surrounding stone.

02: Sound Parlor

Upon a pedestal in the center of the room lay a **flute**. The 3 other passages in this room are blocked by upwards-sliding **doors**, each with a musical note on them.

Flute - (This flute will open the nearest **note door** when someone blows a note, but it deals the blowing player 1d6 damage. Alternatively, the residents of the tower have a secret method to get around by tapping the **flute** on a **door** 3 times, which works without damaging the holder. A fresh flute will appear for every group that enters, and a held flute will fade away when taken away from the dungeon.)

Doors - (Any music **note door** in the dungeon, as marked on the map, requires this flute or one like it in order to open.)

03: Child's Playroom

You hear the creaking of wood as the **ghost of a child** rocks back and forth on a wooden horse. A second **ghost child** plays with little wooden figurines on the floor, next to a third who plays with wooden blocks. A **ghost child** looks up and speaks "You look nice... Can you get us a new **toy**? We're bored of these ones..."

Toy - (If someone brings a child any old **toy**, they will mention that the monsters get around without playing the instruments somehow. If an exquisite **toy** is delivered, the 3 **ghost children** will look upon it with excitement, before bursting, leaving behind 3 ectoplasmic gems worth 200gp each.)

GHOST CHILD – *Adorable or terrifying, take your pick.*

HD1+1 AC10 (only harmed by magic or holy water) ATT#3.

On hit, reduces target's max hp by 1d3.

Cannot be stopped by doors or walls, but will skulk back to room if target retreats beyond the spire.

04: Forlorn Bedchamber

From beyond the door, you hear the weeping of a child.

(Once opened): Before you is a young **ghost child**, weeping into her arms. Before her is a **bejeweled locket**, within it a picture of a woman. There are four small worn beds sized for children.

Bejeweled Locket - (If someone mentions taking the locket or moves to take it, the child's face will distort, as she screams and attacks. The **Locket** looks to be worth 500gp. *I think that's her mother...*)

GHOST CHILD – *Tragic or terrifying, you pick.*

HD1+1 AC10 (only harmed by magic or holy water) ATT#3.

On hit: Reduce target's max hp by 1d3.

Cannot be stopped by doors or walls, but will skulk back to room if target retreats beyond the spire.

05: Dining Lair

A long, **green table** fills the majority of this room, and on each end is a single green chair. On the far wall is a massive **portrait** of the witch, Hagatha. Not the most ugly you've seen, but definitely not the prettiest either. On the left wall is a **window** to a swamp.

Green Table - (If someone sits at the table, a well dressed skeletal butler will emerge from room 06. "I will now take your order." There is no **menu**, but the waiter shall list the options below. If the person makes a fuss, or makes it clear they are a trespasser, the waiter shall retreat to room 6 to get the **bouncers**. Stats listed in room 06.)

Menu - (You may order "Baby back-ribs", Heart-devoire, Oculemon (eyeball soup), or Manling Dumplings. All are cooked with materials harvested from children. Delicious but oh so evil.)

Portrait - (Hagatha's Portrait reads as magic and attacks bounce right off. It's actually a wizard-locked dimension door that leads right to room 61! Can be opened with a knock spell. Hagatha uses it to get downstairs, typically. If it is trespassed, she can end the dimension door effect as she wishes.)

Window – Through this window is a swamp under a purple sky. Low growls can be heard all around. (The window is a portal to a swamp in another world. The growls belong to 6 legged **crocodiles** all too eager to chomp on an unsuspecting meal. If someone lingers for more than a minute, 1d6 **crocodiles** will attack, but will not pursue someone back through the portal, which hangs about 2' above the swamp. An additional **crocodile** will join the fight each round. The upwards limit is 42. There's nothing of value here.)

CROCODILE – 6 legs, 60 teeth. Yowza!

HD3+3 AC12 ATT#2

May grapple on hit to automatically hit the following round.

06: Skeleton Crew

There are accommodations here for 6 servants. Little **rooms** divided by curtains. There are 2 **skeletal waiters**, and 4 bulkier **skeletal bouncers** standing in the room.

Skeletal Bouncers - (Will force intruders to leave, killing them if they have to.)

Rooms – (Simple bed, dresser and chest in each. In one of the **bouncer's** chests is a bejeweled ring worth 800gp. *Is this a class ring?*)

4 x **SKELETAL BOUNCER** – *Good suit, thick arm-bones.*

HD4+4 AC12 ATT#2 xtra1Dmg on hit.

2 x **SKELETAL WAITER** – *Well mannered, well dressed, and at your mercy.*

HD1 AC10.

07: Hall of Hearts

Thump, thump, thumping, the beating of hearts, dozens of them, fills your ears. They are chained to the walls, little tubes sticking out of them, as blood flows through the tubes and all around the room. Behind a pane of glass in the back is a **massive heart**, size of a man, that pumps far more blood. In the middle of it all set into the floor is a pool of blood, that quivers gently. The tubes run both into the walls and into the pool.

Massive Heart – (If someone cuts into it, they will find a condensed blood diamond wedged between fleshy growths on the inside of the heart worth 2000gp.)

This is the blood plumbing. Keeps any blood in the tower from coagulating.

08: Flesh Locker

Dozens of the bodies of children hang from chains, skewered on meat hooks, their heads and several ribs removed. Bits of flesh, rotting and fresh, are scattered all about the floor. Pieces of flesh have been haphazardly **torn** from the bodies here.

Torn - (A **pale flesh-eating creature** with a distended belly and massive orange eyes munches on bits and pieces of child, hiding among the hooks. It is tougher than it looks, and if someone sees it, it shall howl and attack.)

PALE FLESH-EATER – *Distended belly, massive orange eyes. Likely afflicted with mad child disease.*

HD5+5 AC13 ATT#2 xtra1Dmg.

Will stop to eat a fresh kill instead of pursuing a retreating party.

09: Accursed Cookery

A hulking **green creature** without a head, but with a face on its chest, slouches over a cauldron whose contents are periodically stirred. It wears a misshapen chef's hat atop its shoulders where its head should be. On tables and shelves nearby you see tools and spices for meal preparation, alongside jars of eyes, several small human hearts, racks of child-size ribs, and a **disembodied arm** that assists the green chef by grabbing whatever he needs. (*Ingredients mainly come from captured children. Orphans, mainly.*)

Green Creature - (The **Green Chef** will speak, saying: "What is the order?" He is currently cooking heart-devoire in the pot. Is more interested in cooking than fighting invaders, but if attacked he will flee if able.)

Disembodied Arm – (This strange pet-like creature can drag itself around by finger tips, but can also adhere the opposite of the arm to a surface for better leverage. It is not capable of defending itself. Loyal to the chef.)

GREEN CHEF – *Wears an adorable chef hat where his head should be.*

HD4+4 AC12 xtra2Dmg

Excellent with child-sourced bits, but struggles with normal materials.

Floor 2

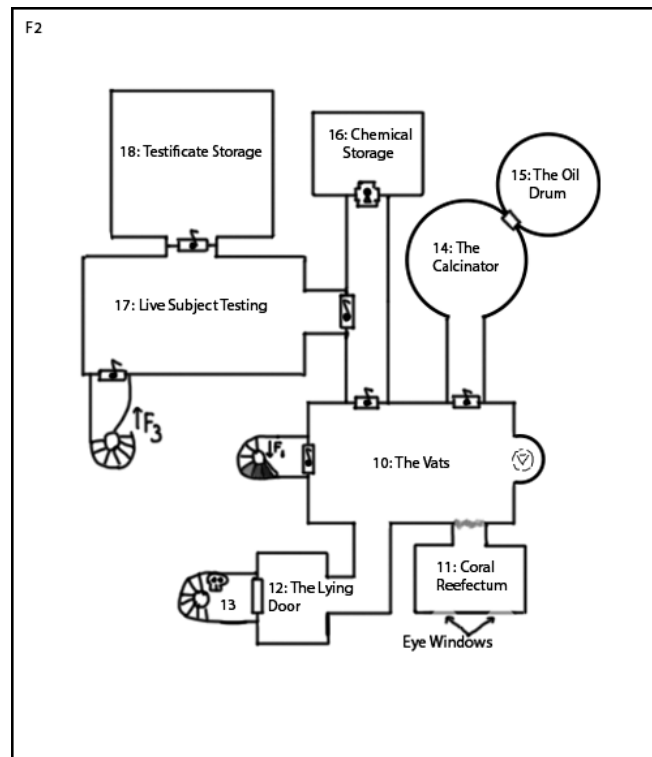
**10: The Vats**

A series of **vats** are carved into the floor, each of them rounded by a metal ring with a label. On the far end of the room is an alcove with some sort of **magic circle**. Presiding over these vats is **Vat-Master Vryguld**, and his two Face-Chesty minions!

Magic Circle - (Master arcanists or lvl6+ magic users will identify this as a teleport beacon, the benefit of which is that when teleporting to this known point, mishaps cannot occur.)

Vat-Master Vryguld – (He may be surprised, but will demand to know what the adventurers are up to, and demand they leave at once. He keeps his distance in a fight, preferring to use his crossbow. His Face-Chesty minions will try to throw opponents into a random vat. See **vats** below for details.)

VAT MASTER VRYGULD – *Green skin, wears a mix of chain and leather, has a massive underbite, and wears thick goggles that might be lenses. Wields a crossbow, but can throw a mean punch.*

HD8+8 AC15 ATT#3 xtra1Dmg.

Prefers to stay back while his minions throw enemies into the vats.

2 x CHEST-FACE BRUTE – *Green, muscular, and headless, as their face is actually in their chest. Very stupid, potentially friendly, easily distracted with food or logic loops. Hagatha is their 'Mother'*
HD4+4 AC12 xtra1Dmg

Food Weakness: If offered food or they see thrown food, they must SvParalysis or pursue the food, forgetting about combat.

Vats - (Vats are 10'wide, 10' deep and typically about 80% full. Each is labeled, see table on next page for contents. Note that if a person is drowning, they take 1d6 damage per round regardless of substance.)

Vats! Roll d8	
1: Blood	It's red and bloody. (Kept in liquid form by periodic churning. Nothing special about the blood, but there are 4 small blood gems at the bottom each worth 400gp. A person in heavy armor will still drown in it.)
2: Bile	Stomach acid. How'd they get so much? (If someone is submerged in it, it'll deal 1d6 damage per turn, so don't stay long. 100 stones of it worth 10gp each to the right buyer. You can still drown in it.)
3: Goobwab	It's sticky, yellowish-orange, and smells strange. Upon close inspection, you see that the goobwab quivers slightly. (If someone falls in, they will be bestowed a random curse each combat round [See room 20 for curse ideas]. It detects as evil. Upon research, an Expert Alchemist will learn it is useful for binding evil magic into potions, reducing cost of such potions by 50%, but consuming 1 stone of goobwab. In truth, this is Demon ejaculate, and will only be recognized by someone who has a LOT of experience with demons, and is quite valuable to the right mortal buyers being worth 1000gp per stone's worth. There is about 100 stones available. Thick enough for heavy armor to swim in.)
4: General Excrement	Exactly what it sounds like. A soupy mix of excrement, solid and liquid from multiple kinds of creatures. Why do they keep this around? (If someone falls in, they must roll morale & SvPoison or contract a disease of the DM's choosing. Thin enough to drown in.)
5: Illithid Ichor	It's pale, slimy, and white. It whispers gently in your mind, in no intelligible language. (If someone falls in, they must SvSpells or be possessed for 1d6 rounds, where they will attempt to remove the brains from their ally's heads, and throw them into the Ichor. Expert Alchemists will know it is useful in mind control potions, being worth 100gp per stone! About 100 stones are available. Thin enough to drown in.)
6: Mortician's Extract	Gray and fetid, it's a soupy mix of bone chips and necrotic flesh. (If someone falls in, they take 1d6 necrotic damage per round. 90 stones worth 10gp each. Thick enough to not sink in.)
7: Silver Lining	Misty, silvery, it is a gas heavier than air. (Does not cushion fall, will take 1d6 damage from falling in. Those who fall in must SvParalysis, or become far too content. A smile will form on their face, and they will be content to just sit tight, unwilling to move. Forever. 10 stones worth 1000gp each, but difficult to transport.)
8: Distilled Corruption	This stuff is corrosive to reality! (If someone falls in, They must save vs corruption each round with a -5, or gain 1d3 points of corruption. It is inadvisable to handle the substance, but if the highly uncommon mercantile-minded demon can be found, the distilled corruption may be sold for 500gp per stone, and there are 200 stones of it. Thick enough to not sink.)

11: Coral Reefectum

A wall of water is suspended in the doorway, and the underwater room beyond is filled with all manner of colorful, shapely **coral**. Some of the specimens look like they may be **valuable**, while others are hideous.

Coral – (If someone enters the chamber, eight **Razor Coral** will become aware of their presence, and they will shoot barbs at their flesh once the trespasser is deep into the room.)

Valuable - (Once the **razor coral** are dispersed, some fantastic coral specimens can be collected

and sold. There are 8 total, each worth 800gp. Weigh 1 stone each.)

8 x **RAZOR CORAL** – *Sharp and malicious. After drawing blood, a long tendril will venture out to slurp up the water-borne blood.*

HD2 AC10, ATT#2 Immobile

Shoots barbs for ranged attacks.

12: The Lying Door

A great door of iron-reinforced oak, with a **brass face** right in the middle.

Brass Face – (When room is entered, the face will animate, saying nothing. If attacked, will howl for help causing a wandering monster check once per round. The **Brass Face** can speak, but is incapable of telling the truth. It must lie, or avoid answering by saying words such as “perhaps”. The door opens normally.)

BRASS FACE – *Just how many curses were lain upon this poor soul?*

HD5 AC17

Cannot attack. Merely screams for help, causing wandering monster checks each round.

13: Spiral **stairs** wrought from stone. They are awash in gruesome blood stains, with small bits of flesh and bone chips here and there...

Stairs – (Small unnoticeable seams between each step. Each step is really a slab, supported by a mechanism ready to smash that slab, and all the others, into the ceiling. There is a **Door** the top of the stairs, also smattered with blood & gore, but the label ‘Treasure Room’ can be clearly seen.)

Door – (If someone attempts to open the door, it will not budge. A sinister giggle will issue forth, and the **stairs** will rapidly rise, smashing anyone upon them into the ceiling. Creatures near the bottom of the stairs may SvBurst to escape. Exceptionally tough characters who have a means to potentially survive still take 10d6 damage.)

Survivors - (Will be rounded up by 2 squads of face-chesties and brought to Hagatha who will add them to the garden in room 56.)

14: The Calcinator

Upon opening the door, **toxic fumes** billow out! A group of skeletons with thick goggles, aprons, and gloves preside over a shallow pit where many small mushrooms smolder. Each of them holds a pitchfork.

Toxic Fumes – (Those in the front rank must SvPoison or take 1d6 damage each round for 1d10 rounds.)

4 x **SKELETONS** – *They oversee the fiery refinement of specific herbs and fauna. Pitchforks are for managing materials, but can be used as spears in a pinch.*

HD1+1 AC12

May attack as if wielding spears.

The air in the room is poisonous until the calcination ceases.

Skeletons – (One of the skeletons carries 800gp worth of jewelry.)

15: The Oil drum

The room contains a dozen **metal barrels**. The air reeks of oil, and the stone of the floor is stained as if wet.

Metal Barrels - (They're all full of fire oil. 60 flasks worth per barrel, each barrel is 10 stones. In the 7th barrel, hidden inside is a **golden diamond ring** worth 1800gp.)

16: Chemical storage

Door is locked (Key is held by Brewmaster Higamok in room 19.)

You see shelf after shelf of various **powders, chemicals, and formulae**. It's a highly disorganized jumble with many unlabeled containers, some of them on their sides leaking contents.

Powders, chemicals, and formulae – (The contents of this chamber are more the more common alchemical reagents and recipes. An Expert Alchemist will note that nothing sticks out as particularly valuable. They may spend a full day sorting and organizing the mess, producing 120 stones worth of **stuff** that can be sold for its weight in silver, worth a total of 1800gp. The alchemical **formulae** may be sold for 1200gp and are much lighter.)

Stuff - (If someone is seeking a particular mundane substance, such as ammonium or magnesium powder, they can find a batch after 1d3 turns of searching).

17: Live Subject Testing

Various **humanoids** and other **creatures** are restrained to wooden tables in this room by leather straps or chains. There are four of the green **chest-face brutes** assisting a blue man with 6 arms.

Humanoids & Creatures – (Various experiments have been performed here. They are injured, disfigured, or dead. Some examples: A horse corpse covered in blue shrooms; a man with a shrunken head, intellect reduced to 1; a corpse wrought by severe necrosis; a man with blind eyes; a badger with teeth so long it can't close its mouth; a person whose legs appear to be made of worms; There are 20 afflicted individuals in here, all of them dead or near death.)

BLUEMAN BEKEMI – *A lab coat, goggles, and bandoliers loaded with mystery potions.*

HD3+6, AC10, ATT#6(Throws vials)

Vile Vial Attack: Touch Attack, target afflicted by a following effect at random:

1 – SvParalysis or be paralyzed 1d3 rounds.

2 – SvBurst or be immolated, taking 1 damage for 6 rounds.

3 – SvPoison or die.

4 – SvPoison or go berserk for 1d3 rounds, attacking nearest target.

5 – SvSpells or be afflicted by fear for 1d6 turns.

6 – SvSpells or become incorporeal for 1d6 rounds, unable to take or inflict damage or cast spells.

Loot: If killed, he will only have 2d6 vials left, which are determined at random.

4 x CHEST-FACE BRUTE – *Green, muscular, and headless, as their face is actually in their chest. Very stupid, potentially friendly, easily distracted with food or logic loops. Hagatha is their 'Mother'*
HD4+4 AC12 xtra1Dmg

Food Weakness: If offered food or they see thrown food, they must SvParalysis or pursue the food, forgetting about combat.

Mother's Instruction: If the Face-Chesties get confused by invaders, there is a chance (morale) they will simply drag the adventurers to the nearest 'boss'.

18: Testificate Storage

Iron bars form 7 cells along the edges of the room. A trough runs from each one, running into the center of the room where there is a dark pit that reeks of sewage. Beside the pit is a single stool, upon which sits a **keyring**. Within the cell are held several **persons** and **creatures**.

Keyring – (Holds the key to each cell.)

Creatures – (7 creatures total, including two horses, a bear, 2 wolves, a bat, and a lion with two heads. They all look weak and malnourished.)

Persons – (10 people total. Weak and malnourished, but can be spoken to if awakened from stupor. One of the prisoners is actually a merchant whose family will reward any rescuers with 5000gp.)

Floor 3

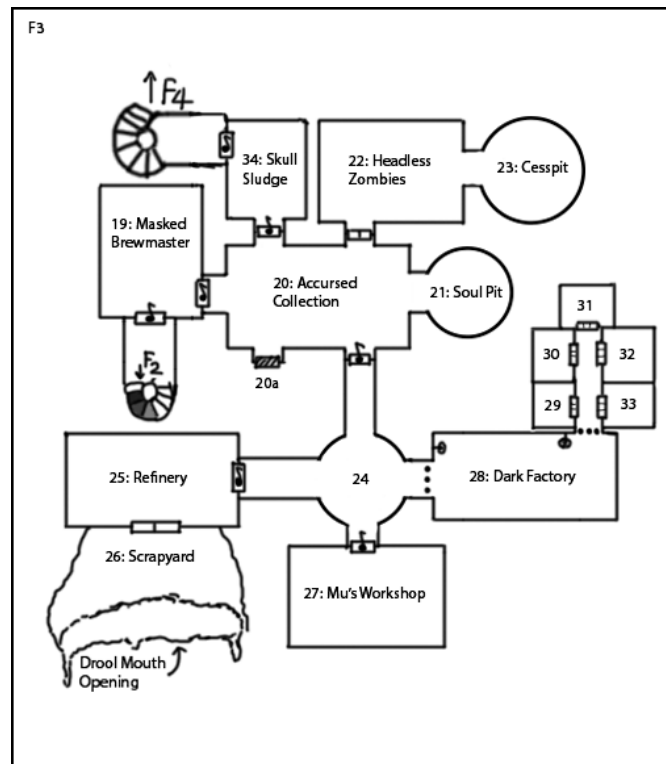
**19: Masked Brewmaster**

A sign on the door reads: DO NOT DISTURB.

A **hulking ape**-like creature with 4 massive arms, covered in thick leathers and wearing an elaborate mask presides over a series of **cauldrons** and other **alchemical equipment**. It looks up and speaks: "Bekemi, I told you not to return until- WHO ARE YOU?"

Hulking Ape – (This is Brewmaster Higamok, and he hates invaders.)

BREWMASTER HIGAMOK – *Hulking and apelike but with four arms. Has 8 glowing flasks on his waist.*

HD7+7 AC14 ATT#4 xtra2Dmg.

Drinks Flask: Uses 1 attack to drink a flask that increases his HD & damage by 1, causing him to increase in size. Starts with 8 of these flasks, their effect lasts for 1 hour. Other attacks used for punches.

Loot: Has a key that unlocks the **vault** under the table.

Alchemical Equipment - (If not destroyed in the fighting, all 30 stones of it may be sold for 500gp per stone for a total of 15,000gp.)

Vault – (Hidden beneath a table in the center of the room. Contains a potion of invulnerability and 3000gp. Invulnerability: Grants resist 10 to all damage for 10 rounds.)

Cauldrons - (Full of mystery brews, halfway through creation, and thus are not discernible or valuable. If someone drinks one down, roll 1d6 for spell level, then roll on the spell tables for the effect; or come up with random effect.)

20: Accursed Collection

The room is full of trinkets, baubles, totems, effigees, and more, haphazardly strewn across tables, hanging from the ceiling, scattered on the floor. There are so many in the room, it's difficult to not **bump** into anything. The **southwest door** stands out, as it is solid black with more than a dozen thick chains keeping it closed. Upon the door is a sign that reads: "Do not enter unless you REALLY know what you're doing."

Bump - (Everything in this room is CURSED. If someone touches an object, roll a d20 on the table on the next page to learn what terrible curse befalls them. If a person moves through the room at normal speed, they must roll a SvBurst with a -4 penalty to make it through without touching anything. Otherwise, it requires 1 turn to move through the room carefully without touching anything. If a person touches a cursed item with an object such as a 10' pole, that object will be afflicted with the curse instead. Assume cursed items have 1d10 charges to prevent permanent weaponization of them.)

Southwest Door - (Leads to the realm of death itself. It is no place for the living, as its grey, lifeless landscapes are patrolled by **reapers** bringing in the lost souls of the dead to store them in the grand phylacterium. 1 **Reaper** shows up per round, having caught the scent of the living.)

REAPER

HD8+8 AC18 Incorporeal SPD15Flying

Drain Life: Targets struck by the reaper lose 2d6 from their *Maximum* Hp value.

d20	Curse
1	(Bloody vomit. Take 1d6 dmg per turn until curse is lifted. Will not reduce a person below 0 Hp, but they will still need to roll on death's door.)
2	(Your limbs seek to murder you. Whenever a weapon is held, that limb will lash out at its master, effectively having that person roll an attack against their self with a +5 bonus on top of their normal attack bonus. When the weapon is removed, the limb becomes docile.)
3	(You no longer know the difference between right and wrong. Character may need to SvSpells to prevent themselves from doing something evil, such as murdering an innocent on a whim or robbing a store. This operates at DM discretion.)
4	(Body no longer cooperates with sexual endeavors. 50% reduction in exp gained from carousal.)
5	(SvCorruption with a -2, or gain 1 point of corruption.)
6	(A fiery rift will form under the person's feet, and 1d20 HD1 demons will attempt to pull the person in. With a successful grapple, the person will be dragged into hell. If the demons fail, the rift will close, and the person will be safe.)
7	(After seven days, an HD8+8 AC12 creature will crawl out of the first painting the character sees, and will focus its efforts on ripping the cursed one to shreds. Others can see the creature and help kill it.)
8	(Lose the ability to regain hit points by any means, until curse is lifted.)
9	(The afflicted's next saving throw will automatically fail.)
10	(Rapid obesity. The curse does not persist, but the obesity does. Character moves at SPD3 until obesity is removed, and can't effectively wear armor or wield weapons. Even their clothes all tear off.)
11	(Curse of Babble. To the afflicted's ears, everyone is speaking an unknown language.)
12	(A silent mummy, that only the cursed character may see, will appear behind them and silently follow. The mummy will not attack, but if it is attacked it will dissolve and reappear in 1 turn. It follows simple orders but cannot interact with the world. However, as soon as the cursed person is alone, the mummy will become corporeal, as an HD4+4 AC13 creature who deals 1d6 damage to maximum HP. If slain in this stage, it will be gone for good.)
13	(Age Reduction! You're 13 years old again. Wisdom & charisma are reduced by 1d6 to minimum of 3, and str/int are reduced by 1d6 to minimum of 8.)
14	(Character's head will morph into their chest. -1d6 charisma (for weirdness) to minimum of 3.)
15	(Character's eyes catch fire, and burn away, inflicting 2d6 nonlethal damage. The character is now blind, but they are now able to "see" anything evil or corrupted such as undead, curses, and demons.)
16	(POOF! Character vanishes without a trace, being zapped 2d20 months into the future. They will reappear at random safe spot within 1 mile, unaware that time has passed.)
17	(Adhesion curse. Everything sticks to you, you can drop nothing. Not even your excrement.)
18	(Encased in evil, unmelting ice. If someone touches the ice, ice will form around them as well. It cannot be moved, and is stuck in place. The person will die in 6 days if curse not removed.)
19	(Instant aging. Gain 1d20 years. Hopefully this doesn't make the character too old.)
20	(You have a cold. Cough, cough. -2 to saves, attack, and damage rolls. Counts as disease or curse. Goes away in 1d4 weeks.)

21: Soul Pit

A gently swirling ectoplasmic pool fills the room. Hanging above it is a **hook** attached to a pulley system, whose rope hangs near the entrance. There are arcane runes upon the **hook**.

Hook – (Can be lowered to "fish" a soul out of the pool. The "fisher" ought to have a method to store the soul, as once pulled out of the pool, it will become agitated within several seconds and attack. There are approximately 512 souls in the basin.)

AGITATED SOUL – *It's grumpy, it wants to go home.*

HD(1d10) AC15 Incorporal SPD15Flying

Drain Life: Targets struck lose 1d6 from their *Maximum Hp* value.

After hitting someone once, will attempt to retreat to the pool.

22: Headless Zombies

The barred door reads, "Don't open, dead inside."

Inside the room are well over a hundred **headless zombies**, all of them wanting to kill those that live. There are grooves in the floor that appear to collect fluids that ooze from the zombies, which lead to the eastern passage.

132 x **HEADLESS ZOMBIE** – *It's vicious and out of control!*

HD1+1 AC10

23: Cesspit

The zombie fluids all lead to this pit. It is full of an absolutely **repugnant substance**. There are **crates** around the edges of the room.

Crates – (Sorted powders, useful for alchemical mixture with **repugnant substance**.)

Repugnant Substance – (An Expert Alchemist can take a look at this substance as well as what is in the **crates** and recognize this a store-house for reagents for a necrotic poison. This poison if injected would force a SvPoison or the target begins taking 1d6 necrotic damage per day for the next 1d20 days. There is enough ingredients here to create 80 doses, each of which is worth 300gp to the right buyer.)

24: **Crates and bins** rest in a haphazard heap, standing 15' high.

Crates and Bins - (Contain metal ingots, various tools, pastes, thread, leather straps, clips, and all manner of intermediate goods. Not much actual value here, but someone could hide in a bin.)

25: Refinery

A hulking **face-chesty** clad in black leathers stands before a great **furnace** which roars with flames. Other smaller **greenish creatures** waddle around the room, carrying bits of scrap metal and giggling constantly. Other small junkpiles lay all around the room, sorted by material type. The southern double door is large, soot-stained, and metal.

Face-Chesty - (Upon hearing the door open he will turn and say "YOUZ GETZ OUT...ZZ.." He says this to anyone who comes in, friend or foe, before returning to his work. He is the **furnace operator**. If he or his workers are threatened, he will attack.)

Furnace - (Used for smelting scrap metal. Scrap is dumped into the top, which can be reached via ladder. The heat source for this furnace is 5 Fire Gems worth 500gp each, which cause fire damage to the touch so be careful.)

Greenish Creatures - (These six **green imps** are tasked with transporting scrap from beyond the double door, and sorting it into various piles by material type.)

FURNACE OPERATOR - *Rather unhospitable. Garbed in thick black leathers to protect himself from his work. Wields a glowing hot metal rod.*
HD8+8 AC14 ATT#2 1d6+3Dmg

6 x GREEN IMP - *Stumpy, mirthful, and vicious.*
HD1+1 AC10

26: Scrapyard

The far wall of this cavernous chamber is absent, providing a sunlit view of the outside world. This appears to be one of the mouths on the masks as seen from outside. All around this chamber are mounds of **junk**. Hanging from the roof are groups of giant, winged **krill**, dozens of them. You see a few more of these creatures flying into the mouth carrying small bits of **junk** before depositing it into a pile and flying back out the mouth.

Junk - (Scrap carried here by the krill, who scrounge the surrounding area. If someone spends a turn digging through it, a damaged golden rod worth 300gp in solid gold will be found.)

Krill - (They're like giant flying shrimp. Scrounge the surrounding area for scrap material, bringing anything back that may be useful. Hostile to anyone who enters the room from the mouth, but not hostile to anyone entering through the big double doors.)

48 x GIANT KRILL - *A giant flying shrimp with wasp wing and many sharp legs.*
HD1 AC13 ATT#4. Weak, but deadly. **48 remain.**

27: Mu's Workshop

You see before you a blacksmith's workshop, within which works another **face-chesty** with tan colored skin who tenderly hammers an odd piece of metal into some unknown shape. Tools hang from the walls. Stacks of ingots and other basic materials sit on the floor around the room.

Face-Chesty - (This is **Mu**, the blacksmith. He's gruff, but non-hostile. He is an expert blacksmith who works to equip whatever forces in the spire require equipment. He is gruff, but non-hostile, harboring no ill-will towards the party. Upon entry, he will say "Ehhh, wotchu want, eh?" If someone touches a tool or something, he'll say "Eehhhhh, you no mess with dat, you no know how use 'em." He can be hired away from the spire, and if attacked will defend himself.)

MU - *A face-chesty with actual tan-colored skin. Wields a heavy hammer, wears blackened leather ovals and has a blackened leather "mask" with goggles built into it.*
HD8+8 AC12 ATT#2 1d6+4Dmg

28: Dark Factory

(Portcullis opened by turning wheel on inside, marked on map).

A dark and terrible **wraith** hovers in the air, it's many arms ending in corporeal hooks. It wields them in a flurry, stitching together errant bits of **flesh** while 5 dark robed humanoids look on in studious contemplation. The room has many high tables with straps and clamps, and there are shelves and racks upon which hang all sorts of equipment and medical gear, and it is all tainted by a smattering of long dried blood.

Wraith - (This is **Darklord Mendacious**, and the 5 robed humanoids are his **dark assistants**.)

Darklord Mendacious is currently doing a live demonstration of stitching together a necrotic monster known as **stitches** who will rise on the second round of combat, if engaged. The group is immediately hostile upon noticing the adventurers, and is eager to get their hands on fresh meat.)

DARKLORD MENDACIOUS - *A wraith whose face and body are masked in darkness, almost like a tear in reality. 8 long arms of black sinew extend from the dark body, each ending with a sharp hook.*

HD10+10 AC17 SPD12Flying

Incorporeal: Unharmful by non-magical or non-silver weapons.

Hook Flurry: ATT#8, 1d6+2dmg. Uses all 8 attacks on the same target if able.

5 x DARK ASSISTANTS - *Grey skinned with horned ridges along skull. Very interested in the necromantic arts.*

HD4 AC10

Mage Spellcasting: Each may cast four 1st-level spells and two 2nd-level spells a day. Prefer to use incapacitation spells such as web or charm.

STITCHES - *A patchwork mess of flesh, bone, and sinew. Jagged pieces of metal protrude from various portions of its "torso" and "limbs". It can hobble around on two stumps. Allied to the Darklord and his students.*

HD8+8 AC10 SPD6 ATT#4 1d6+1dmg

\$ - Upon death, if the body is investigated, four Necrotic Gems can be found which are worth 500gp each. When stuck into a corpse, these gems will animate the corpse under your control. Requires 1 gem per 2 hit dice of fallen creature.

29: Cell # 1

The metal door is locked from the outside. A sliding panel allows vision into the room.

In the room is a **creature** composed of more than a dozen human bodies, all melded together at the waist to form a ring, facing outwards. Their torsos are bent backwards into the middle, so far the faces cannot be seen. The entire thing quivers and gurgles.

Creature - (This is the **Hungerer**, a creature crafted by Darklord Mendacious. It hungers for human flesh. When prey is nearby, a distended over-sized mouth on a thick tentacle will shoot out the middle seeking to latch onto someone and drag them back inside to eat them. Cannot be reasoned with.)

HUNGERER - *Someone stitched together a bunch of bodies at the waist, bent them backwards, then melded the heads into one gaping maw. What a monster.*

HD15+15 AC10 SPD6 ATT#3

Mouth Grab: Lunges out to bite someone for 1d6 damage and grapple them. Upon success, the hungerer may spend another attack action to drag a grappled creature into the central maw, where they will be chewed for 3d6dmg/rd until they can be rescued. Only one target can be in the middle at a time, but the mouth on a tentacle may continue to attack those outside.

§ - Upon death, if the body is investigated, eight Necrotic Gems can be found which are worth 500gp each. When stuck into a corpse, these gems will animate the corpse under your control. Requires 1 gem per 2 hit dice of fallen creature.

30: Cell # 2

The metal door is locked from the outside. A sliding panel allows vision into the room.

The back of the cell is shrouded in pitch-black **darkness**. You can see tiny shadowy hooks flitting about at the edge of the **darkness**.

Darkness - (This blood-thirsty monster is incorporeal, and can fill a 10x10 space with absolute darkness. It chases fleshy creatures, seeking to enshroud them and drain their life force, leaving behind a desiccated husk. It is blocked by physical barriers such as doors.)

HOOK EDGED DARKNESS - *A blood thirsty monster composed of darkness and incorporeal hooks.*

HD10+10 AC16 SPD12

Incorporeal - Only harmed by magic or brightly illuminating effects; a torch won't cut it.

Life Drain - Billows into an area, engulfing as many creatures as it can. Attacks each engulfed creature once, draining 1d6 maximum Hp and healing itself for the same amount. Upon kill, the hook-edged darkness expands by 1', and its hit dice increase by 1.

Upon Destruction - Once defeated, it will leave behind a highly magical heart-shaped object of condensed darkness known as the **Heart of Darkness**. It is a Tier 1 Rare Magical Component that can be used to create a magical item or sold for 12,000gp.)

31: Cell # 3

The metal door is locked from the outside. A sliding panel allows vision into the room.

Three vaguely humanoid **creatures** stand in the room utterly still. The raw red meat of their flesh is exposed with bones sticking out in ways they should not. On what should be their faces is arranged rows of far too many teeth, and they lack any other facial features. Much of their bodies appear bruised and battered.

Creatures - (These **Gore-Imbued Necksnappers** have only one goal: snap necks. If the door opens, they will emit a muted groan and attack, attempting to snap the necks of those they see until all accessible necks are snapped, and then they will stand still. They have no eyes, but they have a form of tremor-sense and life-detection that lets them get the job done.)

3 x GORE-IMBUED NECKSNAPPER - *A fleshy, bony monstrosity that just loves to snap necks. Has extra teeth instead of facial features, but no mouth.*

HD5+5 AC12

Neck-Snap: Only works on a grappled target.

Target must SvDeath, or their neck will be snapped with expert strength and precision.

During a grapple, the necksnapper will have AC0.

§ - Upon death, if the body is investigated, three Necrotic Gems can be found which are worth 500gp each. When stuck into a corpse, these gems will animate the corpse under your control. Requires 1 gem per 2 hit dice of fallen creature.

32: Cell # 4

The metal door is locked from the outside. A sliding panel allows vision into the room.

A ten foot tall hulking humanoid **lizard** creature with thick blades fused with its undead flesh at the ends of its two arms. It stands silently, nearly motionless, blade tips resting on the ground.

Lizard - (Simply known as **Subject 4**, this creature is outright hostile towards everything that stirs.)

SUBJECT 4 - *A big lizard creature whose hands were replaced with heavy blades.*

HD12+12 AC16 SPD15 ATT#2 1d6+5Dmg

₪ - Upon death, if the body is investigated, six Necrotic Gems can be found which are worth 500gp each. When stuck into a corpse, these gems will animate the corpse under your control. Requires 1 gem per 2 hit dice of fallen creature.

33: Cell # 5

The metal door is locked from the outside. A sliding panel allows vision into the room.

A mass of people's heads, all stitched together in undeath to form one moaning, crying **hulk**. It hovers 3 feet above the ground.

Hulk - (It is not hostile, nor does it seem to be aware of anything around it. It will float about aimlessly, uncertain or uncaring about where it goes. Burrowed inside of it are two Necrotic Gems worth 500gp each. When stuck into a corpse, these gems will animate the corpse under your control. Requires 1 gem per 2 hit dice of fallen creature.)

34: Skull Sludge

The floor is covered in a **red sludge**. Occasionally, you see a **skull** bob up to the surface before dipping back under the **red sludge** again.

Red Sludge - (The sludge is poisonous, but only if it enters a wound or is imbibed. In either case, victim must SvPoison or die. Hiding in the sludge are over a hundred **Sludge Skulls** that will attack if perturbed. Creatures may pass through the sludge if they move slowly, allowing a turn to pass to get through the room. Any faster and 1d10 **Sludge Skulls** will leap out and attack the person. **Sludge skulls** do not attack wandering monsters.)

128 x SLUDGE SKULL - *It's red, it's sludgy, and it has a venomous bite. Capable of leaping out of the sludge but otherwise cannot move about.*

HD1 AC10

Venomous Bite: Those bit takes 1d6 damage and must SvPoison, or die.

Magic Item: One of the skulls wears a magical helmet: **Horned Helm of the Deadly Charge** - The wearer may, thrice per turn, instantly close a gap of 10-30' with a charge, slamming their helm into the target and dealing 2d6 damage. Must roll an attack to hit, but on miss will still land in melee with the target.

Floor 4

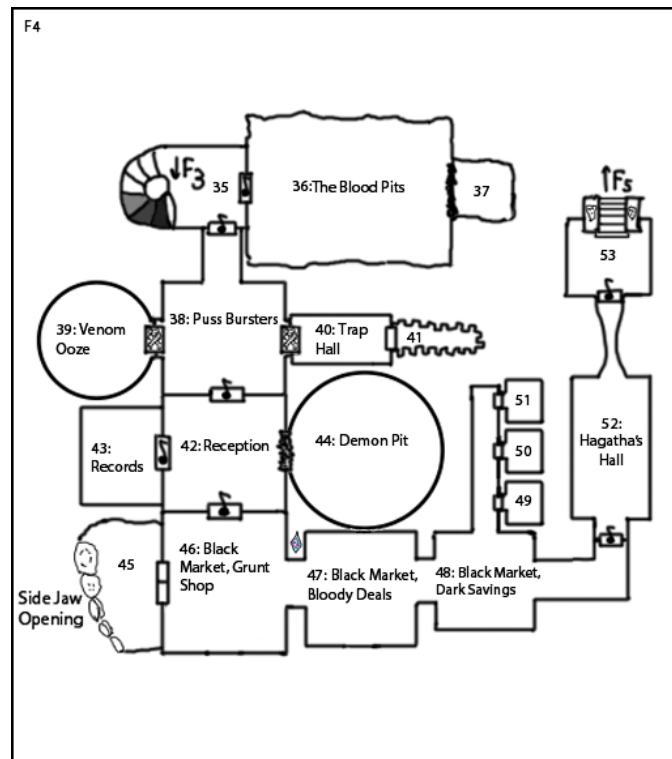
**35: The Happy Bust**

Upon a pedestal at the top of the stairs sits a bust of a **grinning devil**. It speaks in a friendly, cheerful tone, "Why hello, adventurers! Haha... come, COME! Tell me a joke! Gimme a funny, hehehaaaa!"

Grinning Devil - (If someone tells him a joke or a story that is at least mildly funny, he will laugh ridiculously loud, and his laughter is infectious. Everyone who can hear it must SvSpells or be stunned with laughter for 1d10 rounds. Each round of laughter will cause a wandering monster check. The bust detects as evil.)

36: The Blood Pits

(If **Angrash** can see the group, he will yell: "I AM **ANGRASH THE BLOOD-DIPPER**, LORD OF THE BLOOD PITS! AND YOU ARE MY PREY!")

The first thing you see is the massive ten-foot tall dark-**red face-chestian** with a fierce gaze. There

are five other normal face-chestians, but they are covered in blood, just like the **walls**, floor, and ceiling; everything is covered in blood. In the floor are many pits filled to the brim with wet blood and in the center is a large metallic **altar**, with a barbed impaling spike sticking out of the middle.

Red Face-Chestian - (This is **Angrash the Blood Dipper**. He's a rageoholic and attacks enemies without much thought. The other five face chestians are his minions who aspire to their master's level of brutality.

Walls - (Covered in dried blood. The center back wall of the room is actually hollow, and can be broken through with ease to reveal room 37.)

Altar - (If a creature is impaled upon this altar, they take 3d6 damage immediately, and another d6 of damage for each round they remain. Once impaled, a creature will be "grappled" by the altar as if it had HD5+5, so a creature must roll grapple to unstick itself. However, they are dealt the same

amount of damage as their grapple roll total whether they succeeded or failed.)

Angrash the Blood Dipper - *Lord of the blood pits. 10' tall, a hulking red face-chesty with more muscles than he knows what to do with. Seeks to impale enemies on the central altar, or to throw armored enemies into the blood pits where they'll drown.*

HD12+12 AC14 ATT#2 xtra3Dmg

Grab: May grapple up to two targets at a time. Once a target is grappled, Angrash may spend another attack to impale them on the blood altar (attack vs AC with +4 bonus) or throw them into a blood pit.

Angrash Smash: Punches things. Deals 1d6+3 damage.

5 x BLOOD SOAKED CHESTIAN - *Common face-chesty, but flavored with blood.*

HD5+5 AC12 xtra1dmg

Impaler Squad: Multiple face-chesties will gang up to grapple an opponent, such that on the next round they may impale their target on the blood altar if it is unoccupied. Requires attack vs AC with +4 bonus.

37: Behind a mottled wall of dried blood and loose stones is a small room with a giant, **blood-soaked chest**.

Blood-Soaked Chest - (Contains 200 blood gems worth 400gp each!)

38: Puss Bursters

The floor is mottled with what can only be described as **giant pimples** and cysts. The floor is covered with a whitish substance, and the air smells rancid. There are **barrels** in the corners of the room.

Giant Pimples - (Walking through the room carelessly has a 1/2 chance for each person to

burst a pimple, which will cover the person in puss, making them absolutely disgusting and slippery, unable to stand until it is all cleaned off which takes 1d6 rounds. The pimples may spontaneously burst, 1/6 chance per round. New ones form as old ones burst.)

Barrels - (Filled with disgusting pimple juice. 20 barrels total. The barrel closest to the southwest corner has a false bottom, within which is a bejeweled golden mask of a pimply creature worth 2000gp; it'd be worth more if it wasn't so ugly.)

39: Venom Ooze

The metal door is marked with a skull and crossbones, and is barred shut from the outside.

A massive **green ooze** immediately rushes towards the door! Roll surprise.

GREEN OOZE - *It's big, green, and highly venomous.*

HD8+8 AC14 SPD9

Engulf: Uses a touch attack to engulf up to three adjacent person-sized targets. Those struck must SvPoison or die. One target struck may be grappled by the ooze, which will engulf them. For each round inside the ooze, they must SvPoison with a -2 penalty or die. The penalty worsens by -2 each round. In addition, they'll take 1d6 suffocation damage per round.

Upon Death: May be harvested for venom. There are 1d10+10 suitable doses available.

40: Trap Hall

The metal door is marked with a skull and crossbones, and is barred from the outside.

The walls, floor, and ceiling resemble a block of swiss cheese with many **small holes** everywhere, large enough for a spear or arrow to fly through. The **far door** is quite ornate, being solid gold and studded with 50 gemstones!

Small Holes - (Each hole is 3' deep and totally empty.)

Far Door - (It's actually just covered with worthless gold leaf, but the fifty gems are real, and each is worth 100gp. Problem is, if the door is pushed or tugged, even slightly, it will activate a trap. The door will fling open, and long spikes will erupt from behind it skewering the flesh of anyone in the hallway. Attack +15 vs AC for 5d6dmg. After 2 rounds, the spikes return behind the door and it slams shut, resetting the trap.

41: Long spikes and mechanical components make up this trap. (Can be disassembled, but nothing valuable is here.)

42: Reception

If entered from north: A semi-circular **desk** faces the southern exit, and sitting in an uncomfortable chair a green **face-chestian**. He looks over confused, and says "Hey, you need to sign in if you have visitors..." before realizing that you're probably actually intruders, and he proceeds to **scream for help**.

If entered from south: (The **face-chestian** will ask the group to sign in and state their business by putting it in the ledger in front of him. Regardless of what they say, he will tonelessly say "Ok thank you for visit Mad Mask Spire, happy evil goings and behave.)

Desk - (This is the reception desk for visitors to the lower lair, the proper entrance. On the desk is a ledger with a list of names, reasons for visit, times, and received deliveries. Also a neat array of quills and ink. A drawer is full of apples in the shape of fish.)

Scream for help - (For each round he screams, roll a wandering monster check. The Black Market to the south is too noisy to hear him scream.)

CHEST-FACE BRUTE – *Green, muscular, and headless, as their face is actually in their chest. Very stupid, potentially friendly, easily distracted with food or logic loops. Hagatha is their 'Mother'* HD4+4 AC12 xtra1Dmg

Food Weakness: If offered food or they see thrown food, they must SvParalysis or pursue the food, forgetting about combat.

43: Records

Lining the walls from floor to ceiling are **bookshelves**, filled with stacks of **paper**. In the center of the room is a table upon which are three sets of tongs. There are bloodstains on the floor, the table, and many of the **papers**.

Bookshelves - (Each of them are 30' tall and there are 10 total. In the top shelf of bookshelf #6 is a wooden panel that can be slid aside, revealing 7,000gp worth of jewelry and a potion of Might. However, the **papers** will need to be removed, and doing this carefully requires 10 turns per bookshelf.)

Papers - (The papers have been enchanted to have razor sharp edges as per striking enchantment. The tongs are here to safely handle them. Handling paper without tongs causes a secret attack vs AC every few seconds, which deals 1d6 damage on hit. If a stack of papers is knocked off a shelf and flutters about the room, it could be quite deadly with several attacks against each person. You really don't want a paper cut,

here. Dispel magic would only effect one page, but a mass dispel can get them all.)

Unimportant information is kept on these pages in bulk, pertaining to various shipments, old recipe lists, old notes, character sheets, and more. Nothing useful is here, and they have been collected to be a sort of trap.

44: Door is a strange mottled obsidian-like material with sharp edges. (Enchanted to prevent evil creatures from being able to open or even see it.)

Demon Pit

You see a shallow pit, the bottom smeared with an unmoving gooey **black substance**. Before the pit set into the floor is a black slab, engraved with **words**.

Black Substance - (Detects as evil. This stuff is like a corrupted scab that seals the wound from this world to a world of demons. With enough provocation, a demon can push through it. Calling or taunting demons repeatedly will coax one to come through, but it takes a full round to push through the black substance, giving foolish mortals a chance to flee. Demons will have 1d20 Hit dice, 1d4 # of attacks and 1d6+(1d6)damage. Other traits determined by DM discretion. Demons who emerge here are not considered summoned creatures.)

Words - (Upon the black slab, these words appear: "Beckon to the dark minds below, and they shall emerge, to stand beside those above.")

45: **Side Jaw Opening**

There is an opening here to the outside world, lined with humanoid teeth, as if it were the side of a jaw. A group of **Chest-Face brutes** goes about, acting as valets and managing a small **stable** of **strange beasts**. They are aware of your presence, but are not hostile.

Chest-Face Brutes - (They are here to manage arrivals to the black market by air and are here to provide security for mounts as well as valet services. If characters fly through the teeth, they will wave them down and say "Ookay you must needs leave flying creature here, okay? okay." If players enter the room on foot, the brutes will pay them no mind. Suspicious or dangerous behavior may provoke the brutes into attacking, and they'll focus on throwing characters out of the mouth so they may fall to their deaths.)

Stable - (Each **strange beast** has its own cell, and the cells are fully caged so creatures can't fly away. Made of sturdy beams of wood.)

Strange Beasts - (There is **the pear, the one with no hair, the purple bear, the blood blob, the living carpet, and the winged beaked human**. None of them are friendly to anyone who isn't their owner.)

8 x CHEST-FACE BRUTE – *Green, muscular, and headless, as their face is actually in their chest. Very stupid, potentially friendly, easily distracted with food or logic loops. Hagatha is their 'Mother'*
HD4+4 AC12 xtra1Dmg

Food Weakness: If offered food or they see thrown food, they must SvParalysis or pursue the food, forgetting about combat.

Mother's Instruction: If the Face-Chesties get confused by invaders, there is a chance (morale) they will simply drag the adventurers to the nearest 'boss'.

THE PEAR - *A giant miscolored pear with a full set of humanoid teeth rocks back and forth in its stable cell. How it flies is a mystery, but it do.*

HD5 AC10 SPD9Flying

Gibber of Confusion: As its sole means of defense, will gibber offensively. All creature who can hear it must SvSpells or be confused for 5 rounds. Each round, roll 1d6 to determine action:

1-2: Creature attacks itself

3-4: Creature attacks ally

5: Creature does nothing

6: Creature attacks enemy

THE ONE WITH NO HAIR - *An indescribable mass of warty flesh that is disgusting to look at. Has many appendages. Specializes in suffocation.*

HD7 AC10 SPD12Flying

Suffocation, no breathing: Grapples a target with touch attack, deals 1d6 suffocation damage per round. Each round, its grip tightens, adding 1d6 to further grapple checks.

THE PURPLE BEAR - *It's eyes are wide with horror, darting from left to right. It is hunched in a ball, with its paws on its head. It mutters incoherently, and is a coward. Will attack if threatened and unable to escape.*

HD4+4 AC14 SPD15Flying

Purple Swipe: Basic attack; ATT#2, 1d6+1dmg.

Eldritch Breath: Full round action, deals Purple Bear's current Hp total as damage in a 30' cone; creatures affected may SvBurst for half damage. Can only use this ability 3/day.

THE BLOOD BLOB - *A hovering blob of blood that refuses to coagulate. Unlike the others, it seems completely calm, as it does not move. It does have a strange sort of golden pet collar on it with the name "sparkles" Collar is worth 1000gp.*

HD6 AC12 SPD12Flying

Blood Siphon - Will plunge tendrils of blood into a foe and begin sucking their life force out. Deals 1d6dmg to maximum hp value, and overheals its own hit points.

THE LIVING CARPET - *It has a little hand on each of its four corners, and it's using all four to pound on the door of the stable, making quite a ruckus.*

HD4 AC16 SPD15Flying

Carpet Fists - ATT#4, 1d6dmg. Fights like a monk.

WINGED BEAKED HUMAN - *Dressed in white feathers, adhered with tar. Caws loudly every 10 seconds or so. Speaking ability similar to a parrot.*

HD2+2 AC11 SPD12Flying

Beakbite: 1d6dmg.

46: Black Market, Grunt Shop (*Music Suggestion: Spelunky OST Black Market*)

You see before you a bustling marketplace! There are many **shops**, selling various wares. It looks like a dozen of the **Face-Chested Brutes** are providing security here for the **other creatures** in the area shopping.

Shops - (Main shops are the **Shroom Shop**, **Mercenaries for Hire**, and the **Sapper Stash**; see below. Other small stalls sell dubious food, delicious treats, various clubs, and articles of the "Wily Witches" magazine.)

Face-Chested Brutes - (The characters and their coin are welcome here, provided they don't cause trouble. If they do cause trouble, the brutes will go grab the person and say "Okay, you get kicked out now please don't resist." They will drag the person west, and throw them off the cliff in the Side-Jaw-Room, and yell "Come back when you feel like be nice!")

Other Creatures - (This marketplace has attracted other strange creatures of nondescript origin. They carry money, and prefer to flee any combat instead of joining in, but will fight if they must.)

12 x CHEST-FACE BRUTE – *Green, muscular, and headless, as their face is actually in their chest. Very stupid, potentially friendly, easily distracted with food or logic loops. Hagatha is their 'Mother'*
HD4+4 AC12 xtra1Dmg

12 X OTHER CREATURES - *Variable in size, threat level, color, etc. Roll for below stats.*
HD(1d6+1) AC(10+1d4) ATT#(1d2) Dmg1d6+(1d3)
\$ - Each creature carries 1d10x300gp.

**The gem-like object in the wall is Hagatha's Magic Jar. It is positioned to allow Hagatha to discreetly possess a Face-Chesty if needed. If somehow discovered, it is a treasure item worth 10,000gp if sold.*

Shroom Shop		<i>An actual Hag sells potent magical mushrooms! Imbibers must SvPoison at -2 penalty, but may fail on purpose if desired.</i>
Big Shroom	500gp	A white-speckled red mushroom which doubles the creature's size for 1d6 rounds, increasing damage by 1d6 but reducing touch AC by 4. May effect other stats. 4 available weekly.
Small Shroom	400gp	A purple mushroom with yellow streaks which halves the creature's size for 1d6 rounds, decreasing damage by half but increasing touch AC by 4. May effect other stats. 6 available weekly.
Psychedellic Shroom	300gp	A mushroom the color of a fading rainbow. Creature hallucinates for a full day, seeing that which is not there. Creature must SvParalysis else they get a bad trip, seeing only monsters where there once was people. 12 available weekly.

HAG - *Gray cloak, bulbous warty nose, toothless grin. Smells like dirt.*

HD6 AC10

Spellcaster: Casts spells as 6th lvl magic user: 4/2/2

\$ - Has 3600gp behind the counter from other sales.

Mercenaries for Hire		<i>A Gold-Skinned, gem-toothed lizardman sells mercenary contracts. When a contract expires, the hiring party has a chance to renew; otherwise the mercenary will return to the shop. If a mercenary dies, it will not be replaced.</i>
Muscular Lizardman	2500gp /week	MUSCULAR LIZARDMAN - Bronze scaled, wears leather armor, dual-wields scimitars, with javelins strapped to back. HD7 AC14 ATT#2 1d6+1dmg
Face-Chesty for Hire (4 available)	500gp /week	CHEST-FACED BRUTE - Kinda dumb, but pretty tough. Will probably forget about contract if offered food each day. HD4+4 AC12 1d6+1dmg
Hollow Knight	4000gp /week	HOLLOW KNIGHT - a 10' tall suit of armor, completely empty yet animate. Does not speak. Carries a two handed sword in front of it at all times, ready to swing. Improved morale. HD9 AC17 Sword-Smash: Attacks up to three adjacent targets, dealing 1d6+2dmg. Animate: If the hollow knight takes damage, it must be manually repaired and cannot heal.
Goblin Squad	200gp /week	GOBLIN SQUAD - A noisy, giggling squad of 10 goblins with spears and bows and fire bombs. They like to wreck stuff. Hp30 Aim10 AC12 Fire vulnerable - If immolated, will explode killing the squad instantly and dealing 3d6 fire damage to nearby creatures; SvBurst for half damage. Jab 'em: Deals 9dmg on hit. Shoot 'em: Deals 12dmg on hit. BURN DEM ALL: Throws fire bombs, dealing 3d6 fire damage and setting a 10x10 area on fire for 1 turn.

GOLD-SKINNED LIZARD - *He has gems for teeth! Sharp claws.*

HD3+3 AC12 ATT#2

⌘ - Skin worth 500gp if sold, 20 teeth worth 50g each. 8400gp behind the counter.

Sapper Stash		<i>An old man sells explosives designed to be lobbed from an oversized crossbow. He has black eyes and wears chitin armor.</i>
Custer Bomb	800gp	Deals 1d6 structural damage or 5d6 regular damage to everything in a 10' radius. 12 available weekly.
Sharp Point Bomb	500gp	Deals 2d6 structural damage or 7d6 regular damage to a single target; ideal for blowing holes in walls. 24 available weekly.
Big Flash Bomb	700gp	Deals 1d3 structural damage or 2d6 regular damage in a 30' radius. 16 available weekly.
The Big One	8000gp	Deals 10d6 structural damage or 30d6 regular damage in a 30' radius. 1 available weekly.
Lobber Crossbow	200gp	Required for launching these odd bombs. Launches a bomb up to 50' away; the big one can only be launched 30'.

OLD SHOPKEEPER - *Ancient yet solid, with pitch black eyes. Clad in thick chitin plate armor. Smells vaguely of sulfur. Has a concealed shotgun.*

HD15+15 AC18 SPD21

Shotgun Blast: Fires twice in a round, and reloads. Deals 5d6 damage on hit. Has 20 shells available.

Mighty Hurl: When the shotgun is out of ammo, will opt to sprint about, grabbing people and throwing them. Can grab & throw 2 people per round. On successful grapple, will throw a person 30' into the air, or into a wall.

⌘ - Has 14,500gp stashed behind the counter.

47: **Black Market, Bloody Deals:** More shopping opportunities await! More chest-face **brutes** stand guard here while less savory, more **fiendish creatures** peruse the **shops** here.

Brutes - (Still on the lookout for trouble makers. 12 of them total, will drag people to the west and throw them off the cliff in the jaw room.)

Fiendish Creatures - (If a fight breaks out that the face-chesties can't handle, the Fiendish creatures will be more eager to join the fray, to get a taste of blood and glory. Come in various shapes and sizes.)

12 x CHEST-FACE BRUTE – *Green, muscular, and headless, as their face is actually in their chest. Very stupid, potentially friendly, easily distracted with food or logic loops. Hagatha is their 'Mother'*
HD4+4 AC12 xtra1Dmg

8 x FIENDISH CREATURES - *Less savory individuals who are clearly not of this earth... hopefully. Their stats may vary, see below.*

HD(1d4+4) AC(12+1d6) ATT#(1+1d2)

Dmg1d6+(1d4)

\$ - Fiendish creatures each carry 1d10x500gp.

One of the creatures has a key to room 50.

Shops - (Main shops include **Skins to Wear**, the **Manling Pantry**, and **Vampire Blood** which sells vampire blood, it turns out. Other small stalls sell captured maidens to vampires, portraits of "Witches Through the Ages", and blood-based paintings which no honest mortal would see value in.)

Skins to Wear!		<i>Sells the hides of mortals such that undead or other evil creatures may blend in. Managed by a bronze-boned skeleton who wears a human face. Very helpful to his clients and has all the tools necessary to get someone suited up.</i>
Full Human Skin	500gp	Come in various colors and sexes and sizes, but can be refitted by the expertise of the bronze boned skeleton. 5 available weekly.
Just the Head Skin	100gp	The most important part of the skin, really. Good for those who like to swap faces. 5 available weekly.
Empty Braincase	2gp	Extra skulls, buy 'em up! 10 available weekly.
Sack of Bones	10gp	Sometimes you need a full set. Add these to your heap! 10 available weekly.

BRONZE BONES - *His bones are coated in bronze, and he wears a human face.*

HD7+7 AC18 ATT#3

\$ - Holds the key to room 49. Has 3800gp behind the counter.

Manling Pantry		<i>A warm-smiled fiend has human children for sale, along with an assortment of "blood tappers" that can be used to safely drain the blood of a child, extending their effective duration. Yep, he's pure evil.</i>
Manling	1500gp	A human child. In a deep, magical sleep. 8 available weekly.
Blood Tapper	50gp	Used to control the flow of blood from critical arteries. 10 available weekly.
Fistful of Candy	1gp	Useful for luring children away from the safety of their elders. 50 available weekly.

WARM-SMILED FIEND - *Horribly mixed up teeth, blood dripping down his chin. Beady black eyes and black talons. Skin the color of raw, bloody meat.*

HD5+5 AC12 ATT#2

Charming Touch - Instead of dealing damage, may twice a round touch an opponent who must SvsPELLS or be charmed into defending the fiend. This fiend does not have a limit to the number of charms he may have.

💰 - Has 8600gp behind the counter.

Vampire Blood		<i>A vampire sells vampire blood. Who knew? Very informative, can guide clients through the transformation process. Will encourage passerby to take a vial "Just in Caaase!"</i>
Vial of Vampire Blood	2500gp	Drinking it causes the person to become sick for a week, after which they shall become a vampire. Vampires may use a bite attack to drain Max Hp and restore their own hit points, and may feed on the recently deceased to restore hp to themselves equal to the fallen creature's hit dice. 6 available weekly.
Syringe	20gp	Sometimes it's less messy to use proper equipment. 8 available weekly.
Set of Glass Cups & Glass Decanter	20gp	Drink in style! 3 available weekly.

VAMPIRE - *Gleaming white fangs, pale face, slicked back hair, black cloak, and a really lame accent. More like a shampire, right?*

HD7+7 AC16 SPD15Flying

Life Drain: ATT#2, bites target reducing their max hp value by 1d6, and healing himself for same amount.

Bat Swarm: If he feels his (un)life is in danger, will turn into a swarm of bats and flee.

💰 - 5025gp behind the counter. Where that extra 25gp came from, no one knows.

48: Black Market, Dark Savings

Shadowy creatures and dark demons plying goods of questionable intent. Once more, face-chest **brutes** stand guard, though there is fear in their eyes. The shops include **Planned Lichdom-hood, Necromancy for Dummies**, and an odd, **unmarked shop**. Other smaller stalls sell blank spellbooks, alchemical equipment, and creepy dolls.

Brutes - (Anyone who causes trouble will be thrown off the cliff in room 45. If the **Chest-Face**

Brutes can't handle the situation, the **Shadowy Creatures** may lend a hand.)

12 x CHEST-FACE BRUTE – *Green, muscular, and headless, as their face is actually in their chest. Very stupid, potentially friendly, easily distracted with food or logic loops. Hagatha is their 'Mother'*
HD4+4 AC12 xtra1Dmg

6 x SHADOWY CREATURES - *Spooky & silent. Come in various shapes and sizes.*
HD(1d4+5) AC15 ATT#3 Dmg1d6+(1d4)
\$ - Each carries 1d10 x 1000gp.

Planned Lichdom-Hood		<i>A blatant Lich, bones and magic and all, peddles potential magic jars to help you plan your afterlife. He happens to be rather kind, understanding, and helpful. He runs this gig to support his living, breathing children.</i>
Treasure Phylactery	10,000gp	Hardened diamond reinforced with bands of gold and platinum, studded with small gems. The idea is that when those pesky adventurers find it, they'll sell it instead of destroying it. 1 in stock.
Trap Phylactery	8,000gp	Layers of corrosive acid, explosive fire, and poisonous gas protect this phylactery, as your would-be assailants will die as they get closer to the kernel of this bulky phylactery. 1 in stock.
Curse Phylactery	7,000gp	A small yet sturdy phylactery that looks absolutely cursed - and it is. While inside, the resident Lich may alter the nature of the curse placed upon it, as the curse is malleable. 1 in stock.
Weapon Phylactery	8,000gp	A magical & cursed +1 Blade which seduces the wielder by whispering sweet thoughts into their mind, driving them to love the blade, protecting it with their life. Should the wielder fall in battle, the blade will work its charms upon the next wielder. It is a mobile phylactery that is designed to always have a guardian attached to it. 1 in stock.

KINDLY LICH - *Red robe, bony protrusions, not much in the way of finery. His skeletal grin feels warm, if that is even possible. Yellow lights shine in his eye sockets.*

HD10 AC12

Spellcaster: Casts spells as 11th lvl magic user: 4/4/4/3/3/1.

\$ - He's got nothing behind the counter. Poor guy.

Necromancy for Dummies		<i>A smiling demon with far too many eyes clicks its teeth and tongue as it explains that one need only plunge these little gems into their fallen prey to raise them as undead slaves, and that the best part is that they are reusable! Of course, stronger creatures require more gems.</i>
Necrotic Gem	1000gp	May be planted into a corpse to raise the creature as an undead servant. 1 gem is required per 2 Hit dice of the fallen creature. 10 available weekly.

DEMON OF EYES - *Too many eyes. Black blob, many tendrils, sharp clicking teeth, sharp clicking tongue.*
HD8+8 AC14

May use both abilities each round

Bite & Lick: ATT#2, targets take 1d6+1dmg

Corrupt Vision: Focuses eyes on an enemy, who must SvCorruption or they will be blinded permanently as their eyes now serve the Demon of Eyes, who can now see through them. A dispel evil can remove the effect.

\$ - It's got 5000gp behind the counter.

Unmarked Shop		<i>A being of shadow rests quietly behind the stall, saying nothing. Little price tags are attached with labels to some items. Although the items are labeled, there is no description available.</i>
Jar of Ravenous Doom Ants	500gp	(When this jar is shattered, these ants will swarm the nearest flesh at 12 speed, consuming it dealing 2d6dmg/rd. Once the target is fully consumed, the ants will move to the next victim. Immune to physical blows, but an area-of-effect attack will kill them all). 1 in stock.
Mask of Possession	2000gp	(If placed upon a person's face, they must SvSpells or be possessed by the mask. They will be compelled to disembowel everything nearby, and use the entrails to create a ritual circle to rip a hole to a shadowy realm, allowing shadow demons to enter the world.)
Deadly "Poison"	500gp	(Imbiber must SvSpells with a -4 or endure the following: they explode in radiant light, dealing 1d6 radiant damage to everyone within 10' before vanishing. They will have been transported to the shadow realm, never to be seen again.)
Elsewhere Ring	2000gp	(Functions as random planar teleportation. Ideal for situations where you're totally screwed, and "anywhere is better than here". Roll d100 to determine lethality of destination; higher is better.)

SILENT SHADOW - *Unmoving, unspeaking, until it is time to kill. Flits about rapidly, difficult to track as it moves.*

HD10 AC16 SPD21Flying

Insubstantial: Only magical weapons or very bright objects can damage it.

Shadow Glomp: Attack vs touch, encases a target in shadow, forcing them to SvCorruption with a -4 penalty or be turned into a shadow thrall, which will attack the Silent Shadow's enemies. Thralls will be transported to the realm of shadow once fighting has ended, never to be seen again.

49: This metal door is locked. (The key is held by **Bronze Bones** in room 47.)

Guest Room 1

The interior walls are adorned with dozens of portraits of skeletons who partially wear human skin. Against the wall is an open luggage container, empty. Sitting on a small table in the middle of the room is a **bronze bowl**, full of gems!

Bronze Bowl - (It's cursed. Any fleshy creature that reaches inside the bowl will instantly have their flesh ripped from their skin in neat, uniform chunks, killing them instantly. The gems are real, though! 100gems worth 50gp each.)

50: The metal door is locked. (A **Fiendish Creature** in room 47 carries the key.)

Guest Room 2

Within the room is a human child, bound and gagged. On the walls are greasy, blood smeared images of slaughter. Hundreds of dead bodies, half eaten, piled and twisted. Sitting beside a hay bed is a small table with a **blood-red symbol** of the sun.

Blood-Red Symbol - (It is magical, and enables the wearer to eat a corpse to regain hit points without their belly filling up. Also instills the person with a hunger for raw flesh. Consumption requires 1rd/hp, and a corpse may only provide as much Hp as it had in life. Prolonged usage, and the wearer may become addicted to the rush.)

51: The metal door is locked. (It is locked from the inside.)

Guest Room 3

Sitting upon a large **purple cushion** is a humanoid golden-furred **cat-person**. Along the walls are shelves of little golden **cat figurines** that gently

wave a paw back and forth, and they don't seem to be stopping.

Cat-Person - (This **Golden Catman** will be rather irritated if someone barges into his chamber, and will say "You interrupt my meditation, why? It has better be important." Unless a good reason is given, he will demand that they leave, and may even attack.)

Purple Cushion - (Hiding beneath it is a satchel that holds 5000gp worth of jewelry.)

Cat Figurines - (50 figurines total worth 20gp each.)

GOLDEN CATMAN - *Golden furred, sharp fangs, sharp claws. Prefers to focus all attacks upon a single target.*

HD6+6 AC15 ATT#4

52: Hagatha's Hall

Two **stone golems** flank the opposite exit. Each of them have one metal tube for one arm, and a great metal blade for the other arm. They do not appear animate.

Stone Golems - (Once someone enters the hall, both golems will raise their metal arm, which is a cannon, and state in a grinding voice "This area is out of bounds. Please turn back. You will not be warned again." If anyone continues into the room, or makes threatening suggestions, the golems will attack, but will not pursue targets into the Black Market. They may hide in the corners flanking the entrance to get surprise on returning targets. Any target that draws their aggression will be added to a 'blacklist' and anytime either golem sees that individual, they will attack immediately.)

2 x STONE GOLEM - *One arm a cannon, the other a blade. Stands 10' tall.*

HD10+10 AC20 ATT#2 xtra3Dmg on melee..

Blade Attack: ATT#2 1d6+3dmg.

Cannon Attack: Line of effect attack, deals 10d6dmg on hit. Must be manually reloaded, ideally by the Chest-Face Brute in room 53 who is currently taking a nap.

53: Hagatha's Stairs

You see stairs leading straight up, flanked by two square **pillars**. Upon the **pillars** are carved twisted humanoid figures in a state of perpetual agony. In the near left corner is a pile of cannonballs, haphazardly stacked with a chest-face **brute** sprawled uncomfortably on top of them, snoring and mumbling something about delicious stars that would make him bigger.

Pillars - (If someone looks closer, they take 1d6 agony damage, and must save vs spells or be possessed to stair, until interrupted, taking 1d6dmg/rd.)

Brute - (He'll only wake up to significant physical stimulus such as a slab or a stab. Can be easily executed while he's asleep.)

CHEST-FACE BRUTE – *Green, muscular, and headless, as their face is actually in their chest. Very stupid, potentially friendly, easily distracted with food or logic loops. Hagatha is their 'Mother'*
HD4+4 AC12 xtra1Dmg

Floor 5

Wandering Monsters of Floor 5 - Roll a d4 every turn or room, and on a result of 1, roll on the table below. If a monster does not appear, increase the threshold from 1 to 2, and so on until a wandering monster appears.

d10	# of Enemies that appear	Monster Description	Population
1	Hagatha, in the flesh, as well as her Guardian	<p>HAGATHA - <i>Not the ugliest witch, but not the prettiest either. Hook nosed, semi warded, scraggly grey hair, and a bright purple nightgown with pink slippers.</i> HD15+8 AC18</p> <p>Magic Vestment: 15th level permanent effect. Can be dispelled to reduce AC to 10.</p> <p>Spellcaster: Casts spells as 15h level magic user: 5/5/5/5/5/5/2/1</p> <p>Wand of Pain: Wields a wand that increase spell damage by 1 per d6 rolled.</p> <p>Potion of Contingency-Resurrection: Has drank a potion that will restore her to full health upon death.</p> <p>Scroll of Mass Charm Person</p> <p>Scroll of Reverse Gravity</p> <p>Magic Jar: If slain, her soul retreats to her Magic Jar in the walls between rooms 46 & 47. Once here, she can possess a nearby body.</p> <p>GUARDIAN - <i>Twelve feet of bulky metal armor with a giant maul.</i> HD12+12 AC22</p> <p>Smash 'em: Attacks up to 4 adjacent targets with a single swing, dealing 2d6+2 damage.</p>	Just these two.
2	2 Chest-Face Bulkman	<p>CHEST-FACE BULKMAN - <i>It's just a bigger Face-Chesty. Greener too.</i> HD6+6 AC14 ATT#2 xtra4dmg</p>	8 remain
3	Doom Squid Mind Eraser	<p>DOOM SQUID MIND ERASER - <i>It's like squid that swims through the air, defying reality. It fills you with a sense of dread, because it just isn't the sort of thing that should be.</i> HD6 AC13 SPD15Hover</p> <p>Mind Erase: ATT#2, lashes tendrils at two separate targets. On hit, 1d6: damage, self heal, steals x100 experience points. Experience points cannot be retrieved.</p>	Just the one.
4	Gole-Scroll Spell-Spitter	<p>GOLE-SCROLL SPELL-SPITTER - <i>A bewitched scroll that floats about, looking for intruders to unleash its spell upon. May shoot Fireball, Magic Missile, Lightning Bolt, Ice Storm, or Wizard Punch.</i></p>	5 remain
5	1d10 Attendants	<p>ATTENDANT - <i>Thin and frail humanoids wearing white robes and blindfolds. They service the area and keep things organized. Non-combatants.</i> HD1 AC10</p> <p>Blind Sense: They are enchanted with tremor-sense allowing them to "see" the area.</p> <p>Harmless: "We're harmless, really! Please, spare us, we're slaves here afterall!" If allowed to leave, they will find Hagatha and notify her of the invader's presence.</p>	10 remain

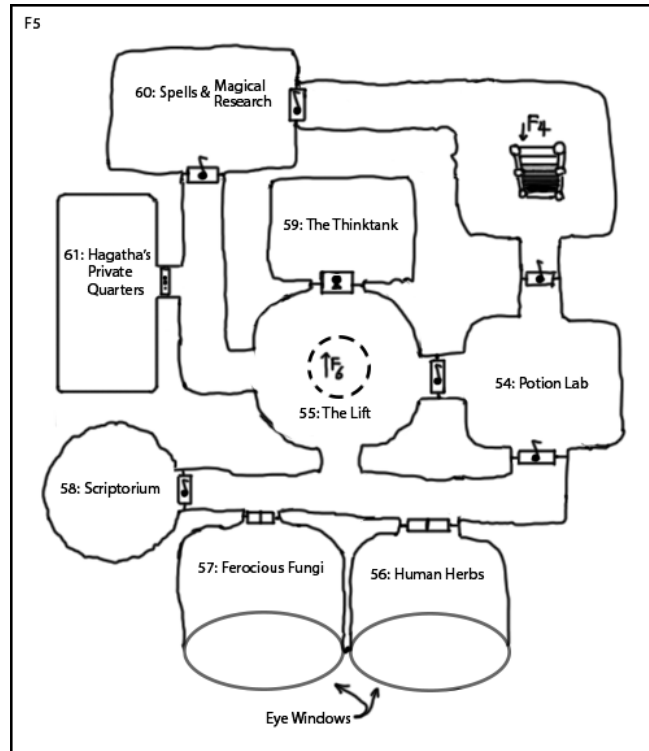

54: **Potion Lab**

This is a potions lab. The floor is stained in all manner of colors and textures. **Alchemical equipment** sprawls across various tables and workbenches, some in an active state while the rest is not in use. A pair of **alchemy-stained gloves** rest on a workbench. There are **potions** scattered all around the lab.

Alchemical Equipment - (The equipment and reagents can be rounded up, and are worth 20,000gp in all, but weigh 40 stones total.)

Alchemy-Stained Gloves - (Wearer gains +1 to potion duplication rolls when creating a potion. In addition, they gain +2 to attack rolls when attacking with alchemical items, such as firebombs, alchemist's fire, lightning bombs, etc.)

Potions - (They come in all sorts of colors and smells and textures, and none of them are labeled. A person may try a drop of a potion to attempt to discern the effect, but this may be not very useful. See table on next page for available potions.)

Description	Actual Name	Effect
Black, reeks of decay	Flask of Necrotic Breath	Imbiber may make a breath attack; all creatures in a 30' cone must SvDeath or die, including the imbiber. OR Throw flask at a location; all creatures within 10' must SvDeath or die.
Red, smells of blueberries	Healing Potion	Heals 10 hit points.
Magenta, smells of chamomiles	Elixir of Charming	Those nearby the imbiber must SvSpells or be charmed by the drinker. This effect lasts 1 turn.
Orange with yellow swirls	Flask of Alchemist's Fire	Throw flask to deal 3d6 fire damage in a 10' area.
Looks like lava, with parsley on top	Potion of Lavafish	Imbiber is polymorphed into a lava fish, and is able to swim in lava for 1d6 turns.
Shifting color	Shapeshifting potion	Imbiber may shapeshift into any creature for 1d6 turns, but cannot become larger than a typical dragon.
Golden, with rainbow swirls	Potion of Luck	Imbiber's next action will critically succeed.
Totally transparent, but sloshes around.	Philter of Invisibility	Become Invisible for 24 hours.
Rainbow of color, with black swirls	Potion of Conjunction	Imbiber may create an object up to 125 cubic feet in size and no more than 20 stones. Object persists for 6 turns.
Glowing white with blue sparkles	Elixir of Extra Life	Upon death, the imbiber will glow with blue light and return to full hit points. Only happens once. Cannot be consumed after death, and the potion only lasts for 1d6 days before the effect dissipates without being used.
Silvery with white streaks	Philter of Perfect Memory	For 1 turn, or 10 minutes, the drinker has perfect memory and may ask DM about any little detail that was explained in the past and they have forgotten. May also give imbiber a random flashback to something important they have forgotten.
Watery with blue suds on top	Elixir of Water Walking	Walk on Water. Lasts 1 turn.
Watery with blue swirls	Potion of Water Breathing	Breath water for 6 turns.
Yellow with green streaks, smells of brimstone	Elixir of Greater Demon Slaying	For 6 turns, imbiber deals an extra 2d6 damage to demons on every attack.

55: The Lift

Dominating the center of the room is a 20' wide **pillar of stone**. A groove separates it from the surrounding floor. The northern door is a large metal thing, with a **giant keyhole** on the front.

Pillar of Stone - (This is a lift that goes up and down, currently in up position. At the top is room 62, the High Scalp. Simply laying a hand upon it when it is not moving is enough to reverse its position. After 1 turn of disuse, will return to the up position.)

Giant Keyhole - (It's a trap! The door will open if Hagatha's fist is inserted into the lock. If someone attempts to pick the lock, or if a knock spell is used, a **swarm of poisonous bees** will erupt and begin stinging everyone in the room. Will pursue those who flee, but will not pursue beyond a door and will return to the lock. The Knock spell will also open the door for 1 turn.)

SWARM OF POISONOUS BEES - *Oh God, why?!?*

Hp200 AC10 SPD15Flying

Swarm: Takes 10x damage from area burst attacks.

Flurry of Stings: May may a number of attacks equivalent to remaining health divided by 10. Attacks are divided evenly amongst targets, and on hit target must SvPoison or die.

56: Human Herbs

The room is full of **various plants**, small in size, clearly being carefully cultivated for harvest. You find it odd, however, as they are all sobbing and quivering, some crying out in despair as they shake. Beyond the herbs is a large **oval window** that matches the eye of the highest exterior head.

Various Plants - (These plants were once people, captured by Hagatha and polymorphed into a reagent-producing specimen. She treats them kindly, ensuring they have full growth potential, but cares not for their imprisonment and eventual execution. These herb-people can be harvested

for 15,000gp worth of reagents, but will die in the process. If the magic is all dispelled and they are freed, there is a rich merchant which will reward 10,000gp to the party. There are 200 plants total.)

Oval Window - (This oculus is highly magical, allowing those who look through to view targets up to 10 miles away with great detail. The window also has true sight, allowing viewers to see anything. Hagatha has this window set up to constantly send her information on whatever the window sees.)

57: A clamor of angry voices can be easily heard from behind the door.

Ferocious Fungi

The room is full of angry **tripedal mushrooms** and they attack the instant they see you.

Opposite wall has an oval-shaped window which matches the eye of the top-most head as seen from outside the spire.

Tripedal Mushrooms - (These are the **Ferocious Fungi**. If they can be pacified without being destroyed, each one can be harvested for 300gp worth of alchemical reagents.)

48 x FEROCIOUS FUNGI - *How could a mushroom be so angry? Roughly the size of a dog, and full of rage. Incapable of diplomacy.*

HD1 AC10 1d6dmg

Poisonous Strike: 50% of these mushrooms have a poisonous strike, so targets may need to SvPoison when they take damage. On fail, target will become paralyzed for 1d6 turns. Mushrooms will continue attacking paralyzed foes until they are splattered.

58: Scriptorium

Shelves are stuffed with **books and scrolls**. A **floating brain** with a spectacle and bowtie, surrounded by an arcane bubble, floats into view from behind a shelf. The arcane bubble seems to be grasping a book, but it sets it down on the central table. "Well, hello there. You seem to be the sort with which I ought not to cavort. Can I help you?"

Books and Scrolls - (Most of the contents will be useless to the party, but the volumes can be sifted through to find useful things. A character may spend 1 turn searching, and on a successful intelligence check, roll a d12 for the table on next page to see what they find.)

Floating Brain - (This is **Ragnar**. He will attempt to defend himself with telekinetic powers, should he be threatened. His arcane bubble is an impressive shield with a variety of effects.)

RAGNAR, THE TELEPATHIC SCHOLAR - *A human brain with a spectacle and a bowtie. Suspended in an arcane bubble. Cheery, proper, and British. Would drink tea if able.*

HD4+4 AC18 ATT#3

Arcane Shield: Blocks all non-magical attacks. Magic Missile is also blocked. Shield also blocks all spells of third level or less from entering. Melee attackers receive 2d6+2 fire damage AND 2d6+2 frost damage per attack made.

Telekinetic Fling: Attacks are telekinetic grabs that fling people 50' into walls and ceilings and the like, but they may SvSpells to resist. Each "attack" hits automatically, but may be saved against.

Magic Spectacle - Enables the wearer to read languages and read magic at will.

d12	Object Found	Description
1	Regional Map	A detailed map of the surrounding area, including cities, ruins, or possibly other dungeons.
2	Wizzorl's Book of Curses	A novel that suggests many potential curses to be placed upon items or people. Refer to room 20 for suggestions or come up with your own.
3	History of Mad Mask Spire	Details the history of this place, showing it is four centuries old and has had 6 masters of the years. Originally created by Guillarmi the Warlock, who raised the spire from the earth. The spire became a trade hub for the wicked several decades back, after life began seeping back into the region.
4	Spell Scroll (10 total)	Holds a random 1st level spell.
5	Spell Scroll (4 total)	Holds a random 2nd level spell.
6	Spell Scroll	Holds a random 3rd level spell.
7	Spell Scroll	Holds a random 5th level spell.
8	Treatise on Madness Waygates	A magical scholar's theory on how the Descent into Madness is a rift between worlds, and serves as a stable, albeit dangerous way to traverse the planes. It has been postulated that it could connect every world in existence.
9	Necromancy and the Nations it Spawns - Analysis by Medrugo	A scholar analyzes different nations that have spawned from necromantic powers, where he argues that most tend in a specific direction of evil, but a significant fraction form into societies that can be considered lawful, or even non-threatening to the living. He further goes on to theorize that at the heart of every great nation is a powerful necromancer, regardless of surface-level appearances of sanctity or justice.
10	Hugo's Funnies	It's a small book of jokes! (Look up jokes online if players decide to read it.)
11	Mok's Mincey Mingles	A book of Ogre poetry. Mok writes of simple things, wicked to the commonfolk but innocent enough through the eyes of the writer. He writes of the pleasure of popping eyes out of skulls, or the beautiful screams of humans as they boil in his cookpot. He writes of the beautiful natural art of blood splatters, and how they send a message to our spiritual selves. . . Wait, Ogres can write?
12	Treasure Map	Leads to a sealed cave in a cliff face 10 miles away. Inside is an automaton, devoid of life, surrounded by ingots of gold and gems. 10,000gp worth of ingots, and 200 gems worth 30gp each.

59: The Thinktank

In a large, rectangular glass case, submerged in a fluid are perhaps a **hundred brains**, of various sizes, all wired together. Bits of electricity run down the wires constantly converging at a conduit near the base of the tank. The conduit runs to a metal chair which has a sort of helmet attached to it.

Hundred Brains - (This nightmarish array allows those who sit in the chair and wear the helmet to crunch some serious numbers, and do their thinking very quickly as needed. Speeds up

research for *anything*, be it magical or technological or otherwise. This device will be of tremendous value to those who use it properly.)

60: Spells & Magical Research

Scrawled notes and small items are haphazardly strewn across tables and chairs, stained scrolls and crumpled balls of parchment litter the floor, earmarked tomes stand in precariously stacked towers, and arcane formulae fill chalkboards before spilling onto the walls themselves. This is a **research center**, albeit an extremely messy one.

Research Center - (Sifting through the contents of this room will take time. Each character may spend 1 turn searching through this room's contents for something useful. If they pass an Intelligence check, roll a d8 on the table below to see what they find.)

d8	Item Found	Description
1	Research into Golem Control	This collection of parchments is 50% complete research into a spell of "Hold Constructs" which would be a 5th level spell. Can also be used to research the 6th level spell, "Charm Construct". The hold works similar to hold person, and the charm works similar to charm person, on all creatures that are animate pieces of non-living material. Does not work on corrupt creatures, such as undead.
2	Research into Stone Shaping & Animation	Once complete, this spell would allow the caster to form a creature out of stone and imbue it with life, under control of the caster. Formed creature would have half the caster's hit dice. Research is 25% complete, and would be a 6th level spell.
3	Research into Stronger Invisibility	This 4th level spell would allow the caster to make a target invisible for 1d6+Caster's level turns, with the advantage that the target may make attacks without losing the invisibility. Research is 50% complete.
4	Death's Doorknocker	Buried beneath a small heap of parchment is a blackened door knocker, that feels eerie to behold. Holding it gives you the impression that death is close. Perhaps too close. It weighs 1 stone, but allows the holder to deal double damage when at negative health. Research on replicating this objects effect is inconclusive. This item is an Artifact.
5	Research into Soul-Stitching	This potential 5th level spell would allow the caster to "stitch" a person's soul into any recently deceased body, whilst restoring that body's hit points to 1, raising it from death. It's like a strange version of raise dead. Research is 30% complete.
6	Research into 'Ever-Steel'	Metallurgical research into non-magical 'ever-steel' that does not tarnish or blemish, and maintains an edge for longer. If delivered into the hands of an expert in the field, that expert could be well on their way to developing ever-steel weapons and armor that could grant +1 attack/damage or +1AC without being magical or of mastercraft quality.
7	Research into Time Reversal	Time Reversal - 9th level spell that allows caster to reverse time in a 30x30 foot area for everything except the caster, potentially restoring life or resetting events. The spell continues for as long as the caster focuses upon it, but cannot duplicate matter in any way. Research is 25% complete.
8	Research into a new source of magic - the Warrens	Unfortunately, research indicates that the warrens are also rife with a chaotic corruption that damages the user's maximum Hit points, and as such, research must proceed carefully. If successful, a person may learn how to tear a rift to someplace such as the Warren of Flame that would spew pure fire into an area for a duration. They could also enter the Warren of Shadow to become one with the shadows, allowing them to traverse safely, minus the potential chaotic side effects therein.

61: (Door is Wizard-Locked by **Hagatha** as a 15th level enchantment. Only **Hagatha** & her **Guardian** are permitted entry. There is a 33% chance that **Hagatha** & her **Guardian** are currently in this room.)

Hagatha's Private Quarters

A **Portrait of Hagatha** hangs on the wall above a large, **lush bed**. There is a **turntable** with a disc upon it. There is a **box, a chest, and a barrel**. A **lush rug** that purrs. The **bedposts** on the bed have little faces that turn to face you; one smiles and one scowls.

Portrait of Hagatha - (The same image as the one down in the dining lair. This is because the two are linked. The portrait is actually a wizard-locked permanent dimension door that connects the two chambers, allowing **Hagatha** quick access to the base of the tower. If this route is trespassed and **Hagatha** is aware, she can end the dimension door effect at will.)

Lush Bed - (Piled high with silks and furs, and the fluffiest and fuzziest of pillows. Irresistibly cozy. So much so that if anyone lay in the bed who is *not* **Hagatha**, they must SvSpells with a -4 penalty or be stuck in the bed, unable to leave. Once dispelled, the bed and its bits can be sold off for 3000gp.)

Turntable - (Able to play music from music discs. Likely considered clarktech to adventurers. Can be activated with a crank, and will play the music: *C418 - Mellohi*. Can be carted off and sold for 2000gp.)

A box, a chest, & a barrel - (These durable containers are magically linked and form an odd puzzle. They must be opened in the correct order for the true contents to appear; otherwise each container will be empty. Any item placed inside will vanish to the true interior once that container is closed. Attempting to move a container will cause the mover to take 1d6 damage, even if moved from afar with telekinesis or similar. The

correct order to open & close containers is as follows: **barrel, barrel, chest, barrel, box, chest, chest**. On completion of this sequence, a ladder will be in the chest that leads down to a black-walled room within which is a heap of 127,000gp worth of gems and jewelry, along with any other items accidentally put inside. Items placed inside will be put in a timeless stasis; this includes people. Attacks and other damage bounce off the containers harmlessly. Containers can be dispelled as if their enchantment were 15th level. If dispelled, the contents will be considered "imprisoned" as per the spell, and require a "freedom" spell to recover the contents.)

Lush Rug - (Once someone gets close, they must roll surprise; the **Lush Rug** will latch onto a person's leg with a touch attack, and begin to nuzzle them while purring loudly. It is harmless, except to vermin which it gobbles up with a little mouth on its bottom side. Does not need to be fed and can be a loyal blanket/pet. Can be sold to the right buyer for 8,000gp if captured alive.)

Bedposts - (The bedposts are disparate voices of encouragement and doubt. Whenever someone has an idea, one of the bedpost faces will give them words of encouragement whilst the other will seek to sow doubt. They are harmless.)

HAGATHA - *Not the ugliest witch, but not the prettiest either. Hook nosed, semi warted, scraggly grey hair, and a bright purple nightgown with pink slippers.*

HD15+8 AC18

Magic Vestment: 15th level permanent effect.

Can be dispelled to reduce AC to 10.

Spellcaster: Casts spells as 15h level magic user:

5/5/5/5/5/5/2/1

Wand of Pain: Wields a wand that increase spell damage by 1 per d6 rolled.

Potion of Contingency-Resurrection: Has drank a potion that will restore her to full health upon death.

Scroll of Mass Charm Person

Scroll of Reverse Gravity

Magic Jar: If slain, her soul retreats to her Magic Jar in the walls between rooms 46 & 47. Once here, she can possess a nearby body.

GUARDIAN - *Twelve feet of bulky metal armor with a giant maul.*

HD12+12 AC22

Smash 'em: Attacks up to 4 adjacent targets with a single swing, dealing 2d6+2 damage.

Floor 6

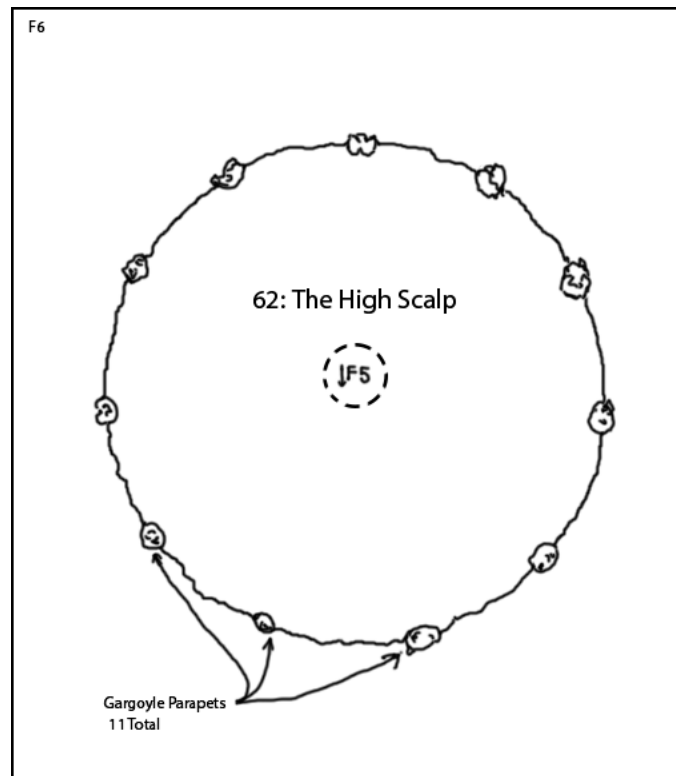
**62: The High Scalp**

This is the top of Mad Mask Spire. There are 11 massive **Gargoyles** perched around the rim. In the center of the High Scalp is a **circular indentation**.

Gargoyles - (These **Gargoyle Guardians** come to life as soon as trespassers are flying nearby or rise up the central lift. They will attack mercilessly, seeking to kill, but will not stray beyond sight of Mad Mask Spire.)

Circular Indentation - (This is the lift to room 55. It can be activated by laying a hand upon it. Once it is no longer in use, it will rise upwards again.)

11 x GARGOYLE GUARDIAN - *10' tall, merciless and without words*

HD8+8 AC20 ATT#3 xtra1Dmg

Magic Detection: The Gargoyles are able to see magic; this way they can detect invisible targets or magical effects.

Regeneration - Outside of combat, each Gargoyle can regenerate to full health in 1 turn.