

for EABA<sup>TM</sup>v2

# Aethos<sup>TM</sup>

light years and millennia from home...

 BTTRC

greg porter



# Aethos™

v1.00 ©2012 greg porter

published by: blacksburg tactical research center(BTRC)

design & graphics: greg porter

art: quentin joubert(cover)  
 tim anderson(chapter 1)  
 vitality smyk(chapter 2)  
 elias khasho (chapter 4)  
 david munoz velazquez(chapter 5)  
 christian bravery(chapter 6)  
 till nowak(chapter 7)  
 orillionbeta (scarthrunner model)  
 petri johansson (cartoo ATV model)  
 christopher haigood (terran APC model)  
 riemen schneider (drinn nightkite)  
 santtu luopajärvi(3D assistance)  
 pimp my gun(weapon design)  
 dukeleto(weapon design)  
 russ bullman, peter saga (alien race development)  
 dan smith(alien races)

useful comments: russ bullman, bret jones, santtu luopajärvi

dedication: to cathy, always

**Aethos** and **EABA<sup>v2</sup>** are trademarks of blacksburg tactical research center. all rights reserved. protected by the universal copyright convention and aliens who will eat some or all of your planet for violations.

<b>INTRO</b>	<b>1</b>
Vignette .....	1.2
What it's about .....	1.3
<b>OVERVIEW</b>	<b>2</b>
<b>Aethos</b> .....	2.2
the Belt .....	2.4
geography .....	2.6
<b>The Aeth</b> .....	2.11
<b>HUMANITY</b>	<b>3</b>
<b>How we got here</b> .....	3.2
the lost heritage .....	3.4
technology .....	3.5
religion .....	3.7
government .....	3.12
law and custom .....	3.14
military .....	3.26
the states of Earth .....	3.30
<b>ADVENTURERS</b>	<b>4</b>
<b>Attributes</b> .....	4.2
<b>Skills</b> .....	4.3
<b>Traits</b> .....	4.8
customs(new) .....	4.9
probation(new) .....	4.16
<b>Sample adventurer</b> .....	4.20
<b>ALIENS</b>	<b>5</b>
<b>Introduction</b> .....	5.2
<b>Drinn</b> .....	5.5
<b>Cartoo</b> .....	5.8
<b>Tuaqq</b> .....	5.14
<b>Ancients</b> .....	5.19
<b>Arkivists &amp; Traders</b> .....	5.20
<b>CAMPAIGNING</b>	<b>6</b>
<b>Intro &amp; structure</b> .....	6.2
The Lost Colony .....	6.5
The Scar .....	6.8
Ghost Ship .....	6.9
Election Rigging .....	6.12
Squatters .....	6.14
Saber-rattling .....	6.17
The Wall .....	6.18
Second Exodus .....	6.19
Forbidden Customs .....	6.22
Harvester .....	6.23
The Big Brain .....	6.24
Espionage .....	6.26
Kasari Observatory .....	6.27
Hate Crime .....	6.29
Temple of Dhuum .....	6.31
Caveat Emptor .....	6.32
Bats over Barstow .....	6.33
<b>Pre-Exodus notes</b> .....	6.39
<b>Organizations</b> .....	6.42
<b>GEAR</b>	<b>7</b>
<b>Aeth gear</b> .....	7.2
<b>Terran &amp; alien tech</b> .....	7.12
<b>Esoteric gear</b> .....	7.24
<b>Terran weapons</b> .....	7.33
<b>Travel times</b> .....	7.44
<b>Gear tables</b> .....	7.47
<b>Adventurer sheet</b> .....	7.51
<b>EABA OSL</b> .....	7.54



Speedpaint March 21, by Tim Anderson  
[timanderson310.cghub.com](http://timanderson310.cghub.com)



*Humans are not native to Aethos. We arrived here, kidnapped, nearly a thousand years ago. Aethos, a planet-sized spaceship, arrived in our ancestral solar system, and tried to dismantle the Old Earth for raw materials. Old Earth forces were not able to completely stop the Aeth, but were able to save the Old Earth from destruction. However, the Aeth did great damage to Old Earth, and also lifted huge sections of it more or less intact and deposited them here, along with the people who lived on those territories. This was the Exodus, a terrible time that both destroyed and remade us as a people.*

*- from Standard Educational Primer, year 3*

## VIGNETTE

They always said it would happen in *his* lifetime, but for a young man, a lifetime is a long time, and Carson never gave it much thought until the skies turned dark and it started raining blood. Not *literally*, but the iron-rich sediments of the Belt were blown into the upper atmosphere when Aethos' engines fired up. They turned the skies a ruddy hue, and the rains that followed were the color of congealed blood and left stubborn brown streaks as they dried.

Carson thought a drive sufficient to move a planet would have a vibration, but he couldn't even tell Aethos was slowing down. Granted, it would take a century to drop to orbital speed for the solar system they were entering, but it ought to shake a *little* bit. *It did rumble sometimes*. The *manuever* jets were the size of supervolcanoes, and when they fired, you could feel the heat a hundred kilometers off. The sound...you didn't *hear* it, you *felt* it.



But what the Aeth did with their planet, they did for their own reasons, living deep inside Aethos and seldom wandering the surface. Terrans were not consulted in the matter, no more than they were consulted when the Aeth kidnapped millions of them nearly a millennia ago and dropped them on the surface to fend for themselves as Aethos slowly accelerated away from Sol, driven off by Earth's space armada.

The news was nothing but the Arrival, pundits, politicians and preachers in equal measure, telling, warning, demanding. The Cartoo were probing the western borders, looking for any Terran weakness, retreating from displays of strength, never *quite* declaring war. The Conscription Laws had not been activated in centuries, but they were still on the books, and were why every young adult still had to get at least a passing grade in marksmanship and fortitude in order to graduate from secondary school.

Everyone had an opinion about the Aeth, and that's about all they had. Despite living on Aethos for nearly a thousand years, Terrans only knew enough about the Aeth to fill a thimble, with plenty of room left for a thumb. The preachers said that this was the beginning of the Last Days, and the chosen fortunate would enter the eternal Kingdom of Man without ever dying, but Carson wasn't so sure. His uncle was an archaeologist, and while he never said so, he hinted that there were a lot of things people took for granted that weren't necessarily so, that history was sometimes less about facts and more about making people feel good about themselves.

Carson was young enough to be conscripted, but old enough to know which jobs and trades were exempt in the various stages of national emergency. On a world with ruins of dozens of dead races and their alien technology, archaeologists were a strategic asset that seldom saw the front lines. *He decided to give his uncle a call...*



## WHAT IT'S ABOUT

Aethos is a hard SF world with the overall trappings of fantasy. *What does that mean, exactly?* It means that:



- the world is bigger than the adventurers will ever know
- there are entities beyond mortal understanding that cannot be challenged or changed
- there is a superstitious dread or religious awe of these forces, with powerful people calling for appeasement and others for hostility
- there are arcane forces unknowable and barely controllable in the hands of a few
- there are non-human races with motivations and goals and needs different than our own
- the world as you know it has been this way for many generations

and last,

- the times, they are a changin'

Aethos is *still* hard SF, it is just that the hardest of the SF is in the hands of beings the adventurers may never meet (and probably do not want to).

The *actual* background of Aethos will be explained in some detail only because this is a science-fiction gameworld and many of you like to read about the foundations and what is behind the scenes. Otherwise it only has as much bearing on things as the solar system would to adventurers in a fantasy world. The background is just that, background, a description of 'what is', to give players a grounding in what is going on and why. To adventurers, it will usually just be things that they take for granted, whether it is true or not. For instance, whether or not the world is flat makes little difference to an adventurer in a fantasy world unless they step too close to the edge. In Aethos, exactly what the Aeth are capable of makes little difference to adventurers. Unless you cross one, in which case the results would be about the same as if you *had* stepped off the edge of the world.

Aethos is meant to put modern adventurers (and their players) in a more primitive state of mind. Millennia ago, the world was a dangerous place, full of utter unknowns. The sun rose and set, but no one knew what it was. They just knew that as the seasons changed and the days grew short, life left the land. Disease could strike from nowhere, taking young and old, rich and poor, powerful and powerless alike. The vital rains sometimes did not come and there would be a drought, or they would pour so much there would be a flood. Fiery-haired stars crossed the sky, heralds of doom. The sun would darken in midday for no reason, and sometimes the earth would tremble, bringing the strongest of mortal works to the ground with ease. Nature and everything in it seemed capricious and sometimes even spiteful.

And when people struggled to understand 'why?' and 'how?', they were armed with little more than trial and error. If their wife was in difficult labor and they swore to offer a sacrifice to the mother goddess if they survived, and they did, then it was a data point that said 'praying to a deity helps'. If there was a drought and the rains came after everyone threw their shoes into the river and danced barefoot in the streets, then you get a data point about 'how to end a drought'. If the livestock deaths stopped after you burned that odd old woman hermit, you got a data point about 'burning witches is a good thing'.

From these things traditions, superstitions and even religions evolve, accumulated irrational behaviors based on ignorance, an incomplete understanding of the world, or the human need to assign a reason or purpose to explain why bad things happen to good people. People who are otherwise highly rational carry deep-seated irrational beliefs about the things they cannot explain. *Black cats are unlucky. You can curse someone by wishing them ill. Certain numbers have a mystical significance. The sun is a flaming chariot driven across the sky by a god.* And so on.



*Aethos is a high-tech version of this.* Humans on Aeth are just as rational as you or I, but they live on a world where there are things that simply *cannot* be explained through rational thought, analysis or the scientific tools at their disposal. The saying by Arthur C. Clarke that "any sufficiently advanced technology is indistinguishable from magic" is at work here. And many, *many* humans on Aethos fall into the same trap as primitive humanity. They confuse coincidence with correlation, give magical qualities to the unexplainable, and assign human values and motives to forces that do not share those values and motives. *They believe what they want to believe because it makes them feel good to believe it, because to believe the truth would make them less important in the grand scheme of things.*

**Aethos** is a world where people go about their high-tech daily lives, because they have to eat and keep a roof over their heads, but it is also a world where people have a deep, superstitious dread of powerful forces that are both real and beyond understanding. They hope, seek and sometimes pray, to appease, cajole or even control forces far beyond their understanding. These unknown forces make otherwise reasonable people act in unreasonable ways. This can be dangerous, both to themselves, those who may be under their authority, and even to all humanity. For unlike the ancient gods, the Aeth are *real*, they *did* ravage the Earth and getting their attention focused on you is not likely to be good thing.

So, you have the high-tech world of things that adventurers can understand, the Aeth, which they cannot understand, alien neighbors whose values and goals may not be compatible with yours, human leaders subject to the temptations of power and the irrationality of centuries-old tradition and belief, plus a major change that will affect everyone on the planet over the course of a campaign. *Everything you need for a smashing good time.*

The difference between a Greek believing that a volcano was an entrance to the underworld and a human on Aethos believing that a scarth tower is an entrance to the world of the Aeth from which no one returns is that for the human on Aethos it is *true*...

### For the players

This is what you, as human inhabitants of Aethos know as truth, the legends and history you were taught in school, what is known by examination of the artifacts and the historical record.

*Humans are not native to Aethos.* We arrived here, kidnapped, 935 years ago. Aethos, a planet-sized spaceship controlled by the Aeth, hollow and several times the size of Earth, arrived in the solar system of our ancestors after a century-long deceleration, and tried to dismantle the Earth for rare elements and raw materials, choosing Earth rather than other bodies in the solar system for reasons known only to the Aeth. The Ancients, a previously kidnapped race living on Aethos, warned Earth of the threat long before the Aeth reached the inner solar system, giving humanity several decades to prepare a defense. Earth forces were not able to completely stop the Aeth, but were able to save the Old Earth from destruction. However, the Aeth did great damage to our ancestral homeworld, and also lifted huge sections of Old Earth more or less intact and deposited them here, along with the people who lived on those territories. This was the Exodus, a terrible time that both destroyed and remade us as a people.

Their merciless raiding interrupted, the Aeth withdrew back inside Aethos and left our homeworld behind, taking us with them. We, no longer the nations of Old Earth, simply christened our new lands 'Earth', in honor of the world we left behind.



The battered survivors brought to Aethos were almost immediately attacked by the Cartoo, another kidnapped race, aggressive and rapacious. We fought them off, not just once, but several times over the centuries, and remain to this day in not a state of peace, but merely a cease-fire. The Drinn and Taaqq, our other neighbors, are more peaceful, and we trade with them and view them as friends.

Aethos is huge, with far more surface than the Old Earth, and three tiny suns instead of the one larger one our species evolved beneath. There are many other races across Aethos' vast surface, some we have yet to meet, others long extinct, known only by their ruins.

We cannot and will not ever forgive the Aeth, but neither can we challenge them. *Yet.* We are forever separated from the world our people came from, but we will always have a part of it beneath our feet.

The above is what you were taught, history in the most respected tomes, the gist of scary childhood fairytales and the most enduring dramas and legends. Like most good lies, it has kernels of truth embedded in it. *Which parts are true and which are false is up to the gamemaster...*

It is a mix of fact, hope, supposition and outright fabrication, but it is nonetheless what most people (including your adventurers) will believe. *At least at first.* Pointing out any internal inconsistency in the story is like telling a member of the Christian faith that there is no tangible evidence of the resurrection of Christ, or telling a Muslim that Muhammad was merely a leader, not a Prophet. That is, it will be met with incredulity, pity or hostility. For most people, a false belief that makes you feel good is preferable to a less uplifting truth. Whether an *adventurer* feels this way or not, or learns things that change their perspective (and what they do about it) *can* be a major part of the campaign.

What was written above is nearly as good as holy writ for the vast majority of Terrans. In addition, there is *actual* holy writ derived from the Old Earth faith called Christianity that adds another layer of drama and supposition to the tale, education or indoctrination that most people have heard since they were children. In this writ, the Aeth are literally the agents of Satan, living in a hellish underworld beneath your very feet, bound there by God and human heroism until the Final Battle that will defeat them once and for all and usher in an eternity of human rule over the universe.

Not everyone believes every bit of the Final Testament, but most believe some, and some do believe all. The Aeth are enigmatic, rarely seen, seemingly immortal, immensely powerful and have nothing comparable to human values. They are different at a level we cannot understand, and for humans, it is often only a small step from 'different' to 'evil'. That final battle against the Aeth is prophecied to be a thousand years after the 'New Kingdom' was founded. It has been 935 years since the Aeth kidnapped humanity, and Aethos is once again slowing down as it approaches a new solar system. Many believe that this is the start of the Last Days, as prophecied in the Final Testament, and indeed, the signs prophecied *are* coming to pass...

You are going to be playing ordinary (or extraordinary) people or even aliens, living on Aethos at the start of its Arrival in a new solar system. For humans, this is the first time, and the most dangerous. If a race transplanted to Aethos is going to go extinct, odds are high that it will happen because of events transpiring in the first Arrival after they were transplanted. Everyone is going to be on edge, for generations. Space programs will be restarted for the first time in centuries, and the Aeth, long unseen, are much more likely to be out and about. Despite the tempest, the lives of most will remain about the same. But adventurers? *Their lives are about to get a lot more exciting...*



## OF GREAT IMPORT



If you are going to truly wrap your head around Aethos, to run it as a gamemaster or experience it as a player, you need to understand the Aeth. *Or more particularly, realize that you cannot understand the Aeth.*

The Aeth are, despite the beliefs of some humans, mortal creatures of flesh and blood. *Alien* flesh and blood, but physical beings bound by the same laws of the universe as everyone else. The Aeth have just figured out how to bend a lot more of those laws to their will and whim. Just as you and I are flesh and blood creatures, so are dogs, cats, mice and ants. You would not expect even the cleverest dog to understand even the simplest human technology. With training, use it, perhaps. But *understand* it? *Never*. Mice? You can train them to run a maze or push a button to get a pellet. Ants? You cannot really communicate with them at all.

The Aeth have a level of mental development that puts them high enough that humans are somewhere down below a dog in comparison. We do not understand the Aeth because we *cannot* understand the Aeth. It is difficult for us as rational thinking beings to grab onto the notion that other thinking beings can be so far beyond us that we cannot even understand their concepts, much less their technology. *Would a mongrel appreciate the Mona Lisa? Would a housecat understand the notion of a parliamentary system of government? Do mice understand the nature of potential energy in that coiled spring the tasty piece of cheese is attached to?*

*No, they dont.* And humans are the same way with the Aeth. In our own limited way we put the Aeth into the *only* conceptual framework we truly understand, *ours*. We try to force their motives and desires through the filter of our own preconceptions, and this is like trying to shove bricks through a sieve.

So, as a gamemaster, player or adventurer, remember that the Aeth are 'just there'. They are *not* the 'great mystery' that the campaign is meant to solve, they are *not* hidden patrons, they are *not* defeatable villains. They are 'just there', like the suns in the sky. You take them into account, but you cannot do much about them, any more than we on Earth could do anything about the Sun if it decided to belch and obliterate the Earth.

*We know it is possible, we know we cannot do anything about it, and we go on with our lives.*

You and your adventurers are free to speculate on them all you want, and these speculations *can* have important ramifications in the *human* sphere, but in the end, you not only will be wrong in some way, you are incapable of even understanding the right answer. Even the questions humans ask about God are more likely to be answered correctly by religious scholars than questions about the Aeth are. For after all, man was supposedly made in the image of God, which is a lot closer than we are to the Aeth. Though God is an all-present being, existing everywhere past, present and future, we convince ourselves that God has 'human' qualities, a form in whose image we were made, yet seldom ask ourselves why God apparently needs eyes, hair or toenails. It is a contradictory part of our belief that gets shuffled off to one side in favor of the deeper truths believed by adherents of the Judeo-Christian faiths.





*It is the same with humans and the Aeth.* The humans of Aethos project their own feelings and needs onto them, making them gods, devils or scapegoats for humanity's problems, and as long as this makes them feel good, they ignore any inherent contradictions in this belief. Challenging human beliefs about the Aeth *is* going to drive many adventures and possibly get adventurers in a lot of trouble, but just as challenging the Church during the Protestant Reformation did not generate the final answers to the questions we ask about God, neither will a successful challenge to beliefs about the Aeth generate the final answers to the questions about them. *But it was useful nonetheless...*

We apologize if this is belaboring the point, and we will *still* bring it up from time to time later on, but you need to understand what you *cannot* understand if you are to have a good time in an Aethos campaign. The Aeth *are* out there, and there may even be very rare interactions between them and adventurers, but these will always be unfathomable and bizarre, and if you think you understand why the Aeth did or did not do a certain thing, you are almost certainly *wrong*.

### What *is* Aethos, then?

Aethos is at heart, a high-tech/espionage/thriller/alien culture/exploration setting, with overtones of religious fervor, superstition and fear. The Aeth and Aethos *are* important overall elements, but they are in the end, part of the setting, *not* its major players (at least as far as the adventurers are concerned). From a *player* standpoint, the background can seem a little dark, or even overpowering. Old Earth is lost to you, and you are humanity's only remnant on this vast and still mostly unexplored planet.

But from the standpoint of the *adventurers*, what has happened to Old Earth or humanity in the past is as distant and emotionally insignificant as the Dark Ages or the Black Death are to us. Yes, these things *did* shape the history of the world and to some extent modern beliefs, but no, they are *not* emotional baggage that people carry around with them. Despite a potential one hundred fifty year lifespan, humans are still largely focused on the present, near future and recent past, all of which are going to become more exciting and emotionally influential as a campaign progresses.

An Aethos campaign can *simultaneously* have aspects of *James Bond*, *Indiana Jones*, *Blade Runner*, *Alien Nation* and *Casablanca* (if some of these do not ring a bell, go rent one or two). There are plots both in the short and long term, independent and intertwined, things to discover, things to keep hidden, things that eventually *must* be done and things that should *never* be done, and if the gamemaster is any good, the adventurers are going to be in the thick of it.

### Coming up...

The next chapter deals with the actual world of Aethos and what the *adventurers* know or can readily find out about it, or things that the adventurers do *not* know but which really would not matter if they did. That should be sufficient to get you to the following chapter, which is making your adventurers. Following that is the gamemaster section, which covers the subtle and important difference between what is known and what is *actually* true, adventures and adventure ideas, gear and reference material.



SID 2012

Future City Street, by Vitaliy Smyk  
sid75.deviantart.com

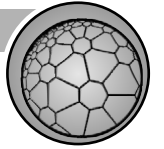

**SCARTH** (*origin:human, etymology:apocryphal*)

*The structural material of Aethos. Usually covered by soil or rock, the native scarth is exposed on the windbreaks between polygons, in the Belt when the maneuver drive is operating, at maneuver jets, in uncolonized parts of Aethos, and on the forward ablation shield after severe impacts. Scarth is incompatible with our current understanding of matter, having properties associated with those theorized for degenerate matter, but without the equivalent mass. Aside from adamantine strength and hardness, its key property is that its inertia does not match with its measured mass...*

- from *Standard Educational Primer*, year 9

## INTRODUCTION

This is a short 'nuts & bolts' chapter about the artificial world known to the adventurers as Aethos. The game-master should read it first and make whatever bits of it known to the players as they feel are warranted. Some of the nature of Aethos may drive adventures, but this is mostly just background information for setting the overall scene.



## AETHOS

Aethos is an artificial world about five times the diameter of Earth, but is much less dense, and has a surface gravity of approximately 1g. The area of Aethos is twenty-five times that of Earth, about half the surface is covered in water (some of which is in the form of ice), and its atmosphere is about 20 percent oxygen and 80 percent nitrogen, with several trace gases, often at a higher percentage than on Earth. In particular, there are larger amounts of noble gases like xenon than are found in the atmosphere of Old Earth, but certain gases like helium are almost non-existent, since there are few underground natural gas reserves to draw helium from (a cylinder of helium like you might see at a supermarket would be worth enough to buy a house). It is not quite identical to Earth's atmosphere and surface conditions, but it is close enough to live on.

Aethos is structurally composed of a material called *scarth*, whose main properties are that it is absurdly strong and completely beyond the ability of human science to fabricate, work, understand or even analyze beyond obvious things like density and color. Scarth or some other material beyond current human theory is necessary to support the onion-like nature of an artificial structure the size of Aethos.

! Inventing a super-strong material for setting or plot purposes is a common science-fiction dodge that goes back as far as E.E.'Doc' Smith's creation of 'arenak' in the *The Skylark of Space* (1928CE). Scarth is, like the Aeth, something that is merely 'there' and is not likely to be a major plot point.

Aethos is hollow, with numerous layers several kilometers thick, spaced about a hundred kilometers apart, going down several thousand kilometers until it opens up into a chamber about two earth diameters across, a chamber that contains what is for all practical purposes, a dark matter annihilator.



Aethos sits at the center of a constellation of three white dwarf stars of roughly .2 solar masses each. These are arranged in an equilateral triangle around Aethos at a distance of approximately five million kilometers, each one orbiting around their combined center of mass in about one hundred forty six hours. Aethos rotates the opposite direction beneath them, fast enough that any given sun seems to make a full circuit around Aethos in about a twenty-seven hour 'day'. The white dwarfs radiate in a spectra a bit whiter than Sol, but excess ultraviolet is absorbed in the upper atmosphere of Aethos, and daylight intensity is close enough to that of Earth that our transplanted biosphere can manage.

In addition to providing heat and light to the surface of Aethos, the high gravity gradient from the degenerate matter of these white dwarfs is used to channel and concentrate ambient dark matter, which is then converted to dark energy and provides thrust in the form of asymmetrical gravity in that region of space. *Aethos simply falls slowly in the direction it wants to go.* Over time, it can and does build up enormous velocities, but it takes the better part of a century to get up to or slow down from its cruising speed of about .1c, making travel between stars a matter of several centuries to several millennia. *The Aeth appear to be in no hurry.*

! This configuration of suns is *not* inherently stable. The Aeth use a constellation of superdense moonlets to make constant minor corrections to the suns during the centuries between solar systems, and the dark matter drive for major maneuvering changes during powered flight.

! At this distance, *one* of Aethos' suns would exert a gravitational pull of a bit more than .1g straight up when it was overhead, but because of the three suns and their near-identical distance from Aethos, they almost cancel each other, leaving a residual tidal force of about .001g, or twice that of Old Earth.

The dark matter drive is a field effect projected from inside Aethos out to a region behind each white dwarf, where their high gravitational field compresses the local dark matter to useful levels. As Aethos rotates under the white dwarfs, this means the field projects through a varying spot on the surface of Aethos in order to maintain position behind each star. The region this field projects through is at Aethos' equator and is called the Belt. While a field influencing dark matter generally has little effect on real matter, the sheer intensity of the field required scrubs the Belt clean of anything but scath as it passes, which it does approximately every nine hours. This region of cleared surface is about two hundred kilometers across, and the projected field moves at a speed of over twenty thousand kilometers per hour along the Belt, causing violent atmospheric disruptions in its wake and influencing weather systems for thousands of kilometers north and south of the equator. The exact position of the Belt varies with whether Aethos is accelerating or decelerating, but the variance in position is minor.

! For those interested, accelerating Aeth up to .1c in a century requires an acceleration of  $\approx .001g$ . To accelerate a mass of three .2 Sol-equivalent white dwarfs up to .1c requires a total amount of energy equal to about one hundred years of the total output of the Sun, and an energy expended per second of acceleration equal to ten seconds of the total output of the sun. Even assuming the Aeth can do this at near one hundred percent efficiency, that's still a *lot* of energy. *Where do the Aeth get the energy for this process?* We do not know, but we presume they are somehow extracting it from the white dwarfs. This will significantly shorten their lifetime, but even if it drops their useful life from billions of years down to a mere hundred million years, that should be sufficient for most purposes.

Do we know that such a dark matter to dark energy drive is even theoretically possible? *Hell no.* But if it *can* be done, the Aeth are the ones to do it. *It is also fun technobabble...*



**The Belt:** The Belt is an unbroken canyon around Aethos' equator, several kilometers deep and two hundred kilometers wide, with steeply sloping sides of crumbled rock and a floor of mirror-polished scarth. *After the drive is active, anyway.* During the long centuries between stars, the area is filled with runoff silt, colonized by various plants and animals, and even members of various races, most of whom have the sense to vacate once the signs of impending drive activation become apparent. To safely cross the Belt during acceleration or deceleration means either flying over, or getting down the slope on one side, across the Belt and up the other side in less than nine hours. The violent winds and vortices left in the drive fields' wake make both ground or air crossings of the Belt a hazardous undertaking. Fast, rugged aircraft are favored for getting personnel across, while convoys of heavy wheeled vehicles are preferred for cargo. Land crossings require that each side bulldoze a ramp down through the scree at each edge for vehicles to make their approach and departure, and the use of multiple vehicles provides redundancy in case of a breakdown.

**The Sky:** The skies of Aethos always have at least one of the three suns visible, but that does not make the sky featureless. When Aethos is at speed, dust and hydrogen atoms impinge on Aethos' magnetic field, and send irregular streamers of light across the sky. These are known as the Northern Lights and are visible down to mid-latitudes in Aethos' northern hemisphere, until they are nothing more than a dim flicker on the northern horizon on exceptionally clear days. When heavy amounts of dust or interstellar hydrogen are encountered, the Northern Lights are visible all the way down to the Belt and cover great arcs of sky in the mid- to northern latitudes.

Normally, there is also a layer of very high atmospheric and EM haze that seems to be a side effect of some Aeth process, and which makes sub-orbital and satellite-based mapping less useful than people would like. No one except possibly the Ancients has a full map of the surface. Most technological races have fairly good photoreconnaissance maps of areas within a few thousand kilometers of their home territory, but aside from specific regions, the coverage further out drops off dramatically. Remember that doubling the radius of your mapping is increasing the area you are mapping by a factor of four and all of this extra coverage is at the extreme end of your recon range. Serni-autonomous high altitude powered gliders are used by many surface races, but the aforementioned haze limits the resolution of the pictures (and they get shot down with distressing frequency).

The pull of the suns generates moderate tides in the seas at the center of each polygon on Aeth and in larger lakes, especially those with an east-west orientation. The moonlets used for course correction on the suns are not visible to the naked eye, but can be observed through special telescopes in the extreme northern and southern latitudes where the air is thinner and clearer. Because at least one sun is always in the sky, there is no true night, making conventional astronomical observations difficult, and it is impossible to keep satellites operational in orbit while travelling at .1c. So, while humans know the next destination of Aethos, observing it is quite difficult. If the Terran government has any big ears in the northern latitudes to listen for or talk to anyone up ahead, it is not public knowledge.

**!** Decelerating Aethos to a virtual stop in one century at its current rate of deceleration means that at the default start of a campaign, Aethos is still about five light-years from its destination. If the Terran government sent a message now, it would be over eight years into a campaign before a reply would be received. And that assumes there is someone on the other end listening for it and able to understand it...



**Climate:** Any given latitude of Aethos has a uniform climate. Equatorial regions are equal to warm temperate to subtropical regions of old Earth. Seasons are minimal to non-existent. The polygon Earth is in is at a middle latitude in the northern hemisphere and is in a perpetual north temperate zone summer. Temperatures seldom get warmer than 30°C after a few sunny days or go below 20°C after a few cloudy ones. Earth has a few regions where air pressure and humidity changes make things permanently subtropical, and the highest peaks on Earth are cold enough to be snowcapped year-round.

As you go further north in latitude from Earth, it gets progressively colder, until you reach regions where average temperature is close to the freezing point of water. These are the limits of habitation and life for most of the surface races, but there are isolated polygons with transplanted life forms comfortable in such conditions. Hundred-meter long iceworms that seek out and eat heat sources were thought a biological and physics impossibility until the recovery of the half-digested logs of the MacDougal Expedition of 633AE... Even further north it is below freezing at *all* times and as you continue north, all water has precipitated from the air and it becomes nothing but dry and rocky wasteland. By the time one reaches this point (about 70° north latitude), you have reached the edge of Aethos' radiation shield, and if Aethos is at cruising speed, you are receiving more radiation than is healthy, and the further north you go the shorter you can expect your lifespan to be. Nothing lives up here, and the only relics of civilization are bits that survived being scraped up from a planet by the Aeth and dropped here as ablative shielding. While it is possible a game plot might involve something left here eons ago, it would not be anything the Aeth are concerned about. However, such items would only be recoverable after Aethos had significantly slowed, which would be years into a campaign.

Going south from the equator is much the same as going north, except there is no need for radiation shielding, and the high southern latitudes are layered in meters of windblown dust over bare scarth, cemented in place by a fine ice of frozen carbon dioxide. The skies around the south pole receive no sunlight, and temperatures at the south pole hover at a near constant -150°C, going no lower only because of radiated warmth from inside Aethos. Both north and south poles warm up considerably during approach or departure from a new solar system, and this opens limited windows for exploration and exploitation of the regions during those intervals.

! The southern polar regions tend to be shrouded in dense mists during the first years of Departure as all the carbon dioxide ice evaporates and turns arriving moisture into ice or water fog. This carbon dioxide in the atmosphere also requires use of environment suits to avoid asphyxiation.

Extra solar input on an Approach will add to the overall energy of Aethos's climate, making weather more violent and unpredictable in the final years of an Approach, but the first effects of this will not be felt for some decades.

! As a linguistics note, the word Aethos derives from the closest pronounceable syllables in the Ancient language, the -os syllable giving the meaning 'place of the Aeth'. The word 'Aeth' predates the Ancients, and they would probably pay a decent price if anyone could prove its origin or derivation. In the Ancient tongue, the ancestral home of humanity is 'Terranos' (place of the Terran). Ancients who do not feel like being polite or tactful will refer to it more accurately as 'Titerranos', the ti- prefix being a temporal modifier, applied to a thing that existed in the past but does not exist in the present (implying that Old Earth no longer exists, contrary to the official human history on the matter). In some usage, the term 'Titerranos' could also mean 'the broken place of the Terran', and the exact meaning in a conversation would be context-dependent.



**Alltrees:** Alltrees are an Aeth-engineered tree, apparently created for the sole purpose of evening out the biological differences between ecosystems. Alltrees are hardy, grow quickly at first and then slower once they reach a certain size. Their wood is suitable for structural use, the leaves are fibrous and can be readily turned into textiles, it has nutritious fruit that is edible to all surface races, though how tasty it is varies by race. The fruits have pits rich in oil, and the alltrees are always in a low level of fruit. The sap can be separated out by simple distillation into the raw material for a rubber substitute, the other part of the distillation is a general purpose pesticide and insecticide and the bark tends to concentrate whatever metals are in the water, soil or minerals around the alltree, making alltree bark a source of very low-level metal ore. The downside is that alltrees suck the life out of whatever soil they are planted in, and thus require a good supply of nutrients to thrive. An alltree that is undernourished will cease growing, only producing fruit appropriate to the soil and water conditions in its area. In most territories, alltree plantations are used to scavenge and purify biological and industrial waste, which they are admirably good at. They are exceptionally important when you remember that most transplanted territories did not include major ore deposits or fuel sources. You cannot run an industrial society on the small supply of alltree oil, but it is nonetheless useful for a variety of purposes. A passable amount of Industrial Era tech could be sustained indefinitely from alltree products and small amount of Atomic or post-Atomic Era tech could be maintained off the rarer elements concentrated in the bark.

Alltrees do not reproduce naturally. The pits must be separated from the fruit and boiled before they become fertile, after which they can be planted. So, alltrees only grow where they were originally seeded by the Aeth, or where a surface race *desires* them to grow. Otherwise they would take over the surface in short order.

! As a cultural note, humans, in all forms of domestic politics and religion, refer to anything referring to human activity on Aethos as 'Earth' or 'Terran', and the world they left behind as 'Old Earth'. In international politics and science, it is generally referred to as 'Aethos'. So, a preacher will speak of uniting all the peoples of Earth under one faith, and a political document might refer to a Terran state, but a trade treaty with another race would use a term like the 'Terrans of Aethos'. Alien diplomats are usually tactful enough to accept the fiction that there are Terrans in places other than Aethos.

**Geography:** *Aethos is freaking huge.* The Aeth transplanted an area of Earth with a total size about the same as Texas, onto a surface that is twenty-five times the size of the Earth. To put that another way, they took one tenth of one percent of Earth and put it on the surface of something twenty-five times as large. In more visually accessible terms, it would be like making Denmark the sole outpost of humanity on Earth, and exploring the rest of the planet had to be done on foot or by sailing ship. The Aeth have placed all the bits they have picked up adjacent to each other in several large patches, leaving the rest of Aethos bare or sheathed in kilometers of planetary debris over its scarth skin.

Aethos' skin is made of scarth of at least several kilometers thickness, with an overall pattern something like a demented soccer ball, with a great variation in size and shape of each region, known as a 'polygon'. The average polygon size is about the same area as North America. Each polygon is higher at the edges and lower in the center, a few hundred to a few thousand meters of elevation difference, with natural irregularities that, lacking any other terrain, would form ponds, lakes and watercourses. Each polygon has a central, irregular sea, rarely with scarth-based islands, and most of the seas are fresh water or slightly brackish.



Though most of the polygons are empty, their water does contribute to Aeth's weather. It is known that the central basins do *not* fill up with sediment, though exactly how it is removed or where it goes is anyone's guess. Sonar probes have found no giant drains under the muck in the middle. It is said (but unproven) that there are huge vents near the north pole, and that ocean sediments are extruded there to be part of Aethos' ablative shield. While weathering of surface rock and soil occurs, no culture has been on Aeth long enough to have erosion of its transplanted bedrock become a culture-critical issue.

Empty polygons are usually desert-like, with shifting dunes of dust blown in from elsewhere, patches of ecosystem around pond depressions where plants have taken root and acted to collect dust and create soil, and a central, slightly brackish sea surrounded by a narrow oasis of plants that have, over the millennia, laid down meters of topsoil that thins out to nothing by several hundred meters inland. Sometimes, alien animals are found here, but mostly the only creatures will be avians. Left to themselves, the various alien ecologies usually reach some sort of stable middle ground, with plants or animals best suited for a particular niche dominating it, regardless of their origin.

Empty polygons are subject to torrential flash floods from rains hundreds of kilometers away. Scarth absorbs no water, so every drop that falls turns into runoff (or evaporates). Shallow natural paths in the scarth can go from dry to kilometer-wide floods in minutes.

Colonies and fringe groups settling in empty polygons will almost certainly use existing oases, and larger groups make take up several kilometers of shoreline for their habitation and farms, as well as introducing fish or other aquaculture. Those concerned with physical security will often make floating colonies a few hundred meters offshore.

The west edge or edges of a polygon have what are called Windbreaks. The capital W is a matter of inflection. The high rotational speed of Aethos (five times that of Earth) can create hellacious weather systems. Windbreaks are huge walls of naked scarth, up to twenty kilometers high, pierced with irregularly sized and shaped holes. The windbreaks create turbulence that disrupts air flow, preventing continent-sized storm systems from ravaging the landscape. The numerous holes allow moisture and cloud systems to pass through, but the windbreaks still block a lot of moisture. Some storms pile up against the east side of a polygon's windbreak and rain down on that patch of land, while the reduced moisture that passes through the holes means that rainfall is significantly less on the other side. Each polygon's central sea provides moisture that both rains on the east side of that polygon and the western half of the next one over.

Over the millennia, native vegetation and organic debris has climbed the steep sides of Windbreaks to heights of up to a kilometer, even clinging to life inside some of the turbulent lower holes in the windbreaks (also some large winged predators nest there). But, with no ability to gain solid purchase on scarth, the ecosystems are unstable, and huge sections avalanche down off the scarth every few decades or centuries. At high altitudes and in more northern latitudes, windbreaks are sheathed in ice, which accumulates in the holes for decades until it collapses under its own weight in massive icefalls that dwarf terrestrial avalanches.

Windbreaks vary in height, starting at ground level at the north and south ends and rising to a central peak. The top of a windbreak is flat, going from hundreds of meters at its base and narrowing to a width of about twenty meters at its highest spot. Some races have managed to place automated surveillance outposts and comm relays on top of windbreaks, held in place with tensioned clamps across the top.





Placing or maintaining such outposts is seldom managed without loss of life and equipment. Since windbreaks are almost always a border between races in adjacent polygons, there are usually diplomatic agreements to prevent weapon emplacements on windbreaks, often with some sort of joint inspection protocol. At the junction between the facets of the larger polygons there is usually an huge access port of some kind to the interior of Aethos. This will be a flared, buttressed tower of scath some hundreds of kilometers across, extending to the top of the atmosphere. These are used for ingress and egress of Aeth terra-deforming ships, and also as exhaust ports for Aethos' maneuvering drive or internal heat regulation (no one is exactly sure). These have a marked similarity to Terran volcanoes. The extra reflectivity from the tower and the increased rainfall around one tends to make it the area a very good agricultural region. However, if that particular port is used as a maneuvering thruster or heat vent, the thermal flux tends to kill everything within fifty kilometers.

*Like volcanoes, people live near them anyway.*

At the junction between smaller polygons or sometimes on a border, there will be a smaller access port, maybe only a few kilometers high and a few kilometers across, sufficient for 'small' Aeth ships, and protected by a huge hemispherical iris door. Around the perimeter at about a kilometer of elevation will be irregularly spaced access doors for individual Aeth. However, these are indistinguishable from surface irregularities, and it seems the Aeth simply exit where it is convenient for them to do so and that any 'door' is a transitory phenomenon, not a fixed portal.

Surface races *can* get inside Aethos via either large or small portals, provided they do so with a small enough physical and energy signature to be considered insignificant. Low-power probes have been dropped into the larger portals from suborbit, and exploration teams have climbed up or been parachuted on top of the smaller portals and then wriggled through gaps in the kilometers-wide iris door.

Not all probes or exploration teams have returned, and no pattern has been discerned as to why. Only brief expressions of surprise or fractional frames of video have been recorded before a lost team stopped transmitting back to the surface, without any anomalous sensor readings or images to indicate why.

The extent of internal Aethos exploration has revealed Brobigandian machinery of great antiquity (but well maintained), traces of ecosystem that have leaked in from the surface, sometimes with signs of habitation by a surface race, and evidence of several or many internal layers, each perhaps a hundred kilometers high. Rare glimpses of these layers show what little is known of Aeth aesthetics and civilization, but those who have actually *entered* these layers have not returned. Verified documentation of any previously unexplored region is worth quite a bit if you can find the right buyer. Small squatter colonies of outcasts from various surface races exist in recesses in the smaller portals, and seem to be ignored by the Aeth depending on their size and technological sophistication. No one is sure what triggers a 'fumigation', since there are seldom survivors if this happens, but it is common wisdom (i.e. unproven) that electricity use, population size and space occupied are factors of importance. Whether this is true or merely 'conventional wisdom' has yet to be proven. Those living in such squatter colonies usually have a fatalistic outlook on life, since no one is aware of any squatter colonies more than a few centuries in age.



The areas without Aeth-transplanted cultures have their own ecosystems based on wind-borne seeds and spores from other polygons. *Untenanted polygons are not necessarily uninhabited.* Outcasts, refugees, communities with fringe beliefs or various explorers can be found there, though rarely more than one or two polygons from a major inhabited region.

There are also ruins of extinct cultures in some of the uninhabited polygons. These could be transplanted races that simply failed to take root, ones that turned inward or on themselves, succumbed to some alien disease, or managed to offend the Aeth in a way that caused them to break out the bug spray and fumigate the polygon.

Aethos is old enough and peopled enough that there are very few *truly* deserted areas. It is just that if you are sharing an area the size of Texas or France with only two dozen hermits, treasure seekers, explorers or deranged loners, it may *seem* deserted. But keep an eye out for those deranged loners...

Last, there are a few 'garden' polygons, which are apparently used by the few Aeth who like the surface for some reason. Those who have actually encountered the Aeth in person probably did so in one of these polygons. Such encounters are unnerving at best. Keep in mind that assuming the Aeth in the garden polygons are there because they 'like the surface' is assigning *human* motivations to them. For all we know, being on the surface could be a form of punishment for the Aeth. These polygons might be the Aeth equivalent of prisons or insane asylums!

While the terms vary with language, Aethos has directions that everyone agrees on. North is towards the front of Aethos (it always faces the same direction while moving), south is towards the rear. East is in the direction of axial rotation, and west is the opposite.

Travel to the far north is unimpeded, though no one does this during the centuries between stars. It is too cold in a physical sense, and too hot in the sense that high energy particles slam into Aethos' magnetosphere and rain hard radiation down onto the surface, along with the occasional bit of interstellar debris that leaves nuclear-bomb sized craters in the thick, ablative layer of planetary debris that the Aeth renew each time they stop in a new system. By the time an interstellar journey has ended, the far north is a mass of shallow craters, glassy debris and naked pockmarked scarth. The edges of the northern latitudes are sometimes mined for metals from asteroid debris left there by the Aeth.

Aethos has three suns, white dwarfs by the way that humans classify them. They are equidistant from each other and Aethos' equator, and far enough from Aethos that there are sometimes two in the sky. Very subtle spectrum distinctions allow most races to distinguish the three, and humans call them Sun, Moon and Star, for reasons lost to history. They rotate around Aethos at a rate such that one sun sets each nine hours (approximately). A full cycle of three suns is a 'day', and for humans, they usually sleep while Star is in the sky. Other races have adapted in their own ways.

! Because of the suns and atmospheric haze, most humans have never seen a night sky with stars. The usual sky is never darker and never clearer than what *you* would see when looking up from the streets of a major city. The first glimpse of a genuine night sky by northern or southern explorers is often a highly emotional experience, the first in-your-face realization that there is an 'out there' we know next to nothing about.



The weather on Aethos is fairly regular, either by design or because the Aeth manage it. Rain falls a little heavier on the lee side of a polygon edge, and the other side of the polygon is drier. Rain falls on average every other day, usually around sunset of Moon, but it can skip a star or double up. On any given sunset, roll 1d+0. If the result is equal or less than the number of intervals since the last rain, it rains. For about an hour, likely giving a centimeter or two of rain.

**i** If the last rain was two sunsets ago, then this sunset it will rain on a roll of '1' or '2'.

Very violent weather is a rarity except near the turbulence of windbreaks. During Approach and Departure, the increased moisture in the air from melted icepacks will cause an increase in average rainfall, but this is not catastrophic. This warming is more of a problem for cold-adapted species living in northern or southern latitudes, who usually adapt by moving underground or to higher altitudes. Technological species augment this with climate-controlled dwellings or possibly even domed cities kept artificially cold.

Normal chaotic weather is typical in regions with high mountains, where you can go from calm to rain or snow or wind in half an hour or less, much as you could in these areas on Old Earth. This sort of unpredictable weather is rare to non-existent around the central seas.

**Aethos and exploration:** Aethos is littered with dead civilizations. Most of Aethos' thousands of continent-sized polygons are superficially empty, but quite a few are the former homes of races and civilizations long-dead, overrun by their own ecosystem and plants and animals from other polygons. Some were decimated by war, civil or otherwise. Some have been looted of virtually anything valuable, others are still rich with pickings. Some were primitive civilizations, nothing left but stone and rubble.

Some were high-tech, but so old that their skyscrapers and infrastructure are dangerously weak. A few are in the process of going extinct, the last survivors fighting amongst themselves, living decadently in ruins, dying of some unknown plague or otherwise on their way out, with outside alien races (including humans) not waiting until the mortally wounded civilization is dead before darting in to grab some choice tidbits.

Most of the genuinely dead civilizations have their share of squatters and hermits, usually well-armed, who resent the intrusion, but are smart enough to no more than take a few pot shots before wandering off to more private climes. More recently deceased civilizations may still have a few cultural defenders, a handful of remaining aliens who know their kind is doomed, but who will use every tool in that civilization's arsenal to keep out looters for as long as they can.

Virtually all the dead civilizations close to Earth were explored extensively by one of Earth's neighbors at least a millennia ago, and the Cartoo, just to be dicks, claim all of the nearby ones not touching Drinn, Terran or Tuaqq territory, and the Cartoo have their own scavenger class that mines ruins for anything profitable. So, nearby polygons with a past civilized presence are by this time, either played out of useful archaeological finds, the colony space of another race, or both.

**!** Keep in mind that because the Aeth take several centuries to travel between the stars, then if civilizations fail on any sort of regular basis, the age of their ruins will also have a relative age of several centuries between them.

**!** It is a popular misconception that the Ancients are the oldest race on Aethos. They are the oldest *surviving* race on Aethos. Ruins or traces that pre-date them by tens of thousands of years have been found.



Large expeditions to distant polygons are multi-month or even multi-year affairs, costing from tens to hundreds of millions of Eur. Depending on budget and goal, they can be very large land convoys that make pretty good speed over open scarth, or several heavy air-lifts to the extent of flight range, followed by ground travel the remaining distance. An expedition requires several scientific teams, earthmoving equipment, security teams (usually with some sort of anti-vehicle or anti-aircraft capability), medical personnel, infrastructure like cooks and assistants, and even a cadre of bureaucrats to keep track of supplies and negotiate with anyone the expedition runs into. Well-funded expeditions will bring a few lightweight air vehicles for scouting, and a research submersible in case something useful is lying under the surface of a polygon's sea. We are talking about a couple hundred people, at least a dozen major vehicles, some of them specialized, and a few dozen more of things like motorcycles and ATVs.

In some cases, expeditions are government-funded, but just as often they are shareholder driven corporate enterprises, where everyone involved has some stake in the success and profitability of the expedition. So, while the cook may be getting a salary automatically deposited to their account back home, they may *also* get some miniscule percentage of any profit from the expedition. This personal stake in the outcome can be significant for the leaders of the expedition, who might also be major funders of it, and this can and has led to ethical problems where doing the *right* thing is not necessarily doing the most *profitable* thing. But since these expeditions are far, far from any official oversight, these lapses are hard to document even if they stray into criminal acts, and the threat of losing one's personal share of any profit is also a downside of being a whistleblower.

## THE AETH

The Aeth are the enigmatic creators of Aethos (we think), though they are far from its only inhabitants. The Aeth only live on the inner layers of Aeth, and do not interact with the surface races to any significant degree.

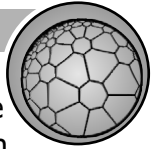

The most important things to remember about the Aeth is that they:

- are not remotely human in any way, save that they *might* have elements of biology with human equivalents
- intellectually speaking, they exceed us to about the same level as we exceed housecats
- technologically speaking, they compare to us about the same as 21st century human tech compares to a chimp using a stick to dig grubs out of a rotten log

*These things cannot be stressed enough.* The Aeth are not just intellectually more capable than humans are, they are more intellectually capable than humans *can* be. We are in the end, fundamentally, *biologically* unable to understand the way they think or discern the principles their technology works on. They do not look like us, they do not think like us, they are not motivated by the same things as us, they do not share our values, aesthetics, morals, social systems or sense of right and wrong. Their devices and the principles they operate on might as well be magic. A dog might learn to use a doorknob, or a chimp might be able to fire a pistol, but neither will ever understand the principles involved in either or ever be able to duplicate them on their own.

The only way humanity will ever understand the Aeth is if we evolve into something that is no longer human. *And that is beyond the timeframe of the game...*



This is not meant to bring you down, but it is humbling nonetheless. We as humans (and gamers) tend to think that with determination, intelligence and a bit of luck, we can achieve anything, or overcome any obstacle. After years of campaigning, our fantasy adventurers storm Hell and challenge the Devil...and win.

*Not the case here.* The Aeth are forces that cannot be appealed to or appeased, and you would really rather *not* have their attention focused on you at all. They are not something that is encountered or challenged. They are merely something that *is*, which adventurers have to take into account. They are the sun god driving across the sky in a flaming chariot. *Except in this case, they are real.*

For the gamemaster and players, the Aeth are best considered a force of nature. They are not a *deus ex machina* to swoop down and save (or ruin) the day, or if they actually do so, it will be sheer coincidence and completely unrelated to any plot that is currently being hatched. They do not care, they do not *need* humans or any other surface race, and if they involve themselves at all in surface affairs, it will be for *their* reasons, not ours. Unlike the gods, they do *not* play with mortal pawns for their amusement.

Consider them the weather. If it is going to rain, use an umbrella or get soaked. If an Aeth is passing by, get the hell out of the way or get squashed. It is that simple, they are beyond the scope of anything the adventurers will ever aspire to. In some respects, this makes the Aeth easy. The Aeth are not going to be fully described in a way that lets you draw an easy picture. All you really need to know is that they are significantly larger than humans, one of their newborns is cognitively more complex than a 99th percentile human, and naked, bound and unconscious (*if* any of those concepts could apply to an Aeth), an Aeth's inherent technology suite could protect it from a late 21st century armored battalion.

The things we consider at the leading edge of theory are things the Aeth discarded long before they even built Aethos, and that was at least a hundred thousand years ago. One of the enduring legends involving the Aeth predates humanity's arrival. It is about the Thernic, an insectoid race transplanted onto Aethos several solar systems in the past (about ten thousand years ago). The tale describes either a fluke success or a long-planned operation that actually killed one or two Aeth, depending on which version of the tale is told. The details are unimportant except for the end of the story.

*The Thernic no longer exist.*

The *entirety* of Aethos is now devoid of *all* forms of Thernic life. There is no molecule of Thernic DNA remaining on Aethos, not a single spore or microbe of Thernic life remains, not in the ecosystem, not in museum specimens, not *anywhere*. What was Thernic territory and civilization was erased of life, and has mostly been taken over by opportunistic plants and animals (and people) after the area became safe to inhabit again. Only inorganic Thernic artifacts in the possession of and records made by other surface races remain to prove that the Thernic existed at all.

Nonetheless, there are Terrans foolish enough to think this is a massive hoax perpetrated by the Aeth in order to keep the 'oppressed races' down.

**Aeth and surface dwellers:** Aeth have a complex set of responses to surface dwellers. Size-wise, Aeth are huge compared to humans or other races, perhaps like an elephant to a person. Intellectually speaking, they relate more like a person to would to a cat, or a person to an insect, depending on individual Aeth. A newborn Aeth probably has the equivalent of an Awareness of 5d+0, several skills at +2d and uses 'best four' for its rolls. An adult probably has an Awareness of *at least* 8d+0, dozens of Awareness skills at +4d and uses 'best six' for its rolls.



Humans are incapable of making Awareness rolls sufficient to understand even the barest fundamentals of Aeth science. *But it does not stop them from trying...*

**i** In strictly game terms, this means an Aeth using an *unskilled* Awareness roll can *reliably* do tasks *more* complex than the smartest, best trained human could do with their best possible roll. Everything else that the Aeth can do is on the same scale as compared to human endeavor.

**!** The very lowest end of the Aeth scale gives the long-term possibility of an exceptionally bright adventurer or extra somehow encountering a baby Aeth, almost but not quite communicating, surviving when the Aeth's 'parent' shows up, and the newborn Aeth remembering the encounter years later upon encountering that person again. This *is* highly improbable, but highly improbable is what rpg adventuring is all about...

How the Aeth respond to encountering the surface races varies with the Aeth's mood, its personality or whatever they have that corresponds to those characteristics. A person might step *over* a procession of ants, or step *on* it, step *around* a spiderweb and admire its beauty, or walk *through* it with a wave of their hand. A person might see an fledgling that has fallen from its nest and gently return it, or simply let nature take its course. The same would apply to an Aeth and a train, town or crashing passenger plane. The fact that an Aeth does not have the same size differential as a person does to an ant makes little difference due to the level of Aeth technology. If an Aeth is moving in a particular direction and does not want to be troubled by obstacles, *those obstacles simply cease to be able to trouble an Aeth*. And if an individual or group of surface dwellers do something that an Aeth considers a threat gesture (a hundred tons of TNT would get an Aeth to notice you like a human would notice a mosquito bite), then the Aeth will make whatever threatened it cease to exist. A human might *swat* at a buzzing gnat, or ignore it.

An Aeth might 'swat' at an attacking fighter jet, or ignore it. And the methods used for such 'swats' are not readily understood or analyzed. Sometimes they cannot even be recorded or detected other than through the sudden absence of the item swatted, or its instant dispersal as tons of various elemental powders over an area of several square kilometers.

The technology an Aeth wields as an extension of its personality is staggeringly beyond the power and scope of human understanding, and utterly out of proportion to their considerable physical size. They are a race that builds (and dismantles) planets and which uses degenerate matter suns as rocket engines. Their personal technology is on a scale to match, and even if the Aeth have become technologically stagnant, it is at a level that humans will not reach until we have physically evolved into a form with a brain complex enough to understand and build that technology. Do not let the idea that they lack warp drives or time travel or teleporters make you think there is room for advancement. In *this* game setting, the Aeth are as advanced as it gets.

**Aeth machinery:** Evidence exists that the Aeth *have* tools scaled for their personal use, but it has never been seen in use. Aeth are known for themselves, their massive ships and Aethos itself, but things on the scale of homes or personal vehicles are absent, not just from human records but from most records of other surface races. There are isolated, unverified accounts dating back several thousand years that describe flying craft *merely* hundreds of meters across, or Aeth seen with what appear to be technological items external to the body of the Aeth itself, but the context in which they were used is garbled or lost in time or in translation.

Humans *have* acquired bits of what seems to be Aeth technology, and while these things are occasionally usable and useful, whether we are using them for their designed purpose is a matter of some debate.





*Behold, he will remove the heavens, and the mountains, the hills and the seas, and all things shall be made plain to the Elect, that it may be rendered unto them the promise which has been made if they keep the commandments, which they have received with great faith.*

*For the repentance of the righteous has its end, and the days of repentance are fulfilled to all the saints, but to the heathen and the alien, there shall be no forgiveness. Whoso denieth, being afraid for his life in this world, shall also deny in the world to come, and shall be cast into the outermost darkness.*

- Final Testament, 3:28-29

## INTRODUCTION

This is the chapter you want to read before making an adventurer. Until now, we have talked in detail about Aethos and the Aeth, but not much about humanity other than history. It is extremely likely that all adventurers in an Aethos campaign will be humans, so the chapter for creating adventurers follows this one, and after that will be information on the non-human surface races on Aethos.

Some of the information in this chapter might give away things the gamemaster wants to keep secret from players at the start of a campaign, so the gamemaster should decide which bits are known and which bits are merely assumed to be true.



## HOW WE GOT HERE

To understand humanity on Aethos, you have to first understand how we got here and how we got to the present in the ten centuries that followed.



**The Exodus** - The popular tale of the Exodus is some variation of the following:

- The Aeth attacked Earth
- We fought back valiantly, driving them back inside Aethos and saving Earth
- But not before the Aeth stole part of Earth and the people living in those places
- The cowardly Aeth have not shown themselves since

The Biblists frame it in terms of Revelations and a battle between Heaven and Hell, but it plays out the same. Their major addition is that of a new Savior with miraculous powers who helped unify humanity on Aethos, stopped the Cartoo invasion and wrote the Final Testament before, like his predecessor, he ascended into the heavens.

What *really* happened is a bit different than the official history, and while the truth of the matter is known at the highest levels of government, it has been kept suppressed for various reasons over the centuries. Some administrations have even considered the truth to be bordering on heresy and simply refused to accept it. Based on the testimony of high-rank military survivors of the Exodus:

- The Aeth dismantled the surface of Earth like an elephant stripping branches off a tree
- Earth's defenses were like a handful of gnats
- Rather than destroying all life on Earth, the Aeth grabbed chunks of the ecosystem and plopped them down on empty spots on the surface of Aethos, something they do with any life-bearing world compatible with Aethos' surface conditions
- Humanity is lucky the Aeth cared to even that limited extent
- Earth was rendered uninhabitable and the humans on Aethos are humanity's sole survivors





! Earth's moon was thrown from its orbit into the sun, forcing the evacuation of lunar colonies to Mars. The fledgling Mars colony survived for several centuries but eventually failed. But not before sending out a cryostasis colony ship in Aethos' wake, a ship which will catch up with Aethos a few years from now. The gamemaster can put it to use for anything their long-term plot requires. This ship is no threat to the Aeth, and is designed as best the Martian survivors could manage so that the Aeth do not swat it out of the sky on approach.

Characteristics common to the transplanted regions of Earth are that they were:

- hexagonal as far as we can tell
- about a hundred kilometers across and two kilometers deep (areas destined to be shorelines of a polygon's sea are thinner on that edge)
- had no nuclear power plants, nuclear research facilities or nuclear weapons (in the late 22nd century)
- not hyper-urban *nor* complete wilderness
- often had a lake of considerable size or a nearly enclosed one (fresh or saltwater).

The Aeth transplanted a lot of these areas from seemingly random spots around the globe, and then set them down right next to each other in a polygon to form a region about the size of Texas, with an initial survivor count of a bit more than twenty million people and several hundred kilometers of shoreline on that polygon's irregular central sea.

The Exodus was obviously survivable, but was *not* kind. The transplanted territory was not lifted gently and deposited lightly upon onto Aethos. Well, actually it was, but only in a very *relative* sense. The Exodus was like a magnitude 8 earthquake that lasted for several *hours* during the removal process, and several more during touchdown, with the electrical equivalent of heavy EMP for much of the trip. Plus, the edges of previously laid territory were melted into lava merely by the weight of the ships laying down new territory.

Basically, no structure was left standing, no infrastructure remained. The relatively benign transplantation process probably killed a million people all by itself, and that does not count the damage done to the alien-occupied areas adjacent to where these giant chunks of land were placed. What arrived on Aeth was people, rubble and thousands and thousands of square kilometers of toppled trees, isolated stretches of river, off-kilter lakes and whatever personal items or vehicles could be salvaged. The Aeth were *not* concerned about our culture or history, they just wanted to save some portion of the Earth's unique biology and dominant species. They figured some of us would survive and adapt, and that was all that mattered to them.

! **The Earth-Cartoo Wars:** Almost immediately after the chunks of Old Earth were transplanted onto Aethos, Earth territory was invaded by the Cartoo, an aggressive species transplanted to Aethos several thousand years ago. This should have been a total rout of humanity, but whether by design or coincidence, the Aeth 'fertilized' their new plot of land with a large number of adult alltrees and perhaps a few hundred of what humans call 'Orbs'. Full details on both of these are later on, but the short form is that the alltrees kept humans from starving, and the Orbs turned ordinary people into Aeth-modified supermen, capable of extraordinary offense and defense, at the cost of their lifespan reduced to a few years at best. It also helped that the Cartoo invaded as an extended series of individual brigade- to division-level raids by local Cartoo bosses rather than a coordinated war run by a central government. Alltrees and Orbs helped humanity beat back the Cartoo for a few decades, giving humanity time to rebuild some of its industry, make alliances with other races and get some surplus military hardware. *Because the Cartoo are nothing if not persistent.* In the 935 years since humans arrived on Aeth, there have been five Earth-Cartoo Wars, and countless border skirmishes, probes and provocations.



Many of the original twenty million humans transplanted by the Aeth died in the first few years after the Exodus, and conflict and other pressure kept the population from expanding as fast as it might have. The current human population is just under three hundred million, most of whom live in humanity's original territory. This is moderately crowded, an average population density of about five hundred per square kilometer. For comparison, this is less than late 20th century Taiwan but more than Japan. Remember that both of these places *still* have forests and mountains and uninhabited areas. It is not wall-to-wall people by any means, it is just more highly urban than most American and European *players* are used to. There are no great unexplored wildernesses, no equivalent of the Amazon rain forest or Himalayan mountain ranges. *At least not in human territory.* Specifically, there *are* places like this in human territory, they are just fairly well explored. There may be places where no one lives, with no roads and no mobile phone coverage, but there are no undiscovered tribes or unscaled peaks, just places too inconvenient to live in.

There *are* enough people and crowding that there is social and political pressure to expand. Fortunately, there is plenty of room to do so. The amount of Aethos that is occupied by anyone is dwarfed by the amount that is not. Unfortunately, everyone wants *someone else* to do the moving, and all the best empty areas in adjacent polygons are also being colonized by other surface races, some of which we are not on friendly terms with. This makes emigration to a new colony much less attractive and not enough people are doing so to offset the rising population pressure. It is just one more thing that is going to be a problem for humanity in the next century or so.

**The Lost Heritage:** Despite several million survivors of the Exodus and numerous towns and small cities sort of transplanted from Earth by the Aeth, very little of the old Earth's history has survived in tangible form. By the late 22nd century, books as we know them fell into *one* category: *Antiques*. Advances in wireless systems, e-paper and the like meant that a simple rollable or foldable tablet could hold by itself as much knowledge as an entire mid-20th century library, and could access text, audio and video from virtually any public knowledge repository in the world, via an ubiquitous and usually free wireless network.

And when what remained of Earth was transplanted to Aethos, every last one of these devices had their circuitry burned out and their memory chips erased or destroyed by electromagnetic flux from the numerous city-sized engines of Aeth transport ships. And then the buildings this tech was housed in were turned to rubble. The only electronics that made it through were the hardwired operating systems in some military tech, and even those were degraded in effectiveness if they worked at all.

As a result, there were only two knowledge bases left after the Exodus. Antique books salvaged from the rubble, and human memory. And while the survivors *did* make an effort to record and teach what they knew, and duplicate the printed word that remained, this was but the merest sliver of human history and culture. Some elements were well recorded, others are completely missing. For instance, a full set of Gibbons' *Decline and Fall of the Roman Empire* survived, but no copies of either the Declaration of Independence or anything except indirect mentions of the Vietnam War.

There are similar gaps in knowledge and ecosystem that the gamemaster can use for flavor. It might be that coffee survived, but chocolate did not. Or vice versa. Rats, roaches, cats, dogs and domestic livestock survived, though horses almost did not make it.



It is said that those who do not learn from history are doomed to repeat it, and this is certainly going to be the case for humanity on Aethos, for they have no history to learn from. In the course of a campaign, the spectres of McCarthyism, the Holocaust, the Inquisition and the Crusades will all raise their ugly heads, and there will be little past history to warn the new Earth of the folly they are about to beget.

**Technology:** Even with three hundred million people, humanity does not have enough people to sustain the technological and industrial infrastructure it had before the Exodus. It *is* considered 'vital to Terran interests' to have indigenous exocap and semiconductor manufacturing. While some aspects of electronics are very advanced, most Terran semiconductors are at a late 20th century level rather than the early 22nd century level the Old Earth had right before the Exodus. Most of humanity lives at a combination between mid-20th century and late 21st century. The mass automation and superfast computing of the latter era is gone, but medical and genetic technology is near what it was before the Exodus. Vehicles may be powered by late 21st century exocaps, but with the exception of the smart roads in and between major cities, they are manually driven on conventional roads. Energy weapons are possible, and even practical as military small arms, but more conventional pistols and rifles are common.

Human technology excels in the fields of medicine and genetics, to the extent that average human lifespan is now 150 years. Much of that increase is because almost full regeneration is possible for damaged organs and lost body parts, with eventual degradation of the brain and premature senescence of regenerated or transplanted organs being the cause of most deaths due to 'old age'. The body eventually stops accepting regenerated or replaced parts, or the new parts put too much strain on the old ones (your new heart pops a blood vessel in your brain, etc.).

A full detailing of technologies and laws or customs applicable to these technologies will be in a later chapter.

Raw materials are a bottleneck for Terran heavy industry. Recycling efforts, imports and mining have thus far kept up with human demand, but metal-intensive items *are* more expensive than on Old Earth. There are a few usable iron and copper deposits left on Earth, but within a century or two it will be more economical to use alltrees as ore instead of mining ever-scarcer deposits on Earth. The only other option is to mine the northern ablation shield. The conditions for this require environment and radiation-shielded mobile refineries to scoop up debris, filter out the fragments of iron-rich asteroids, and then ship the material overland through several environmentally hostile and lawless polygons back to Earth. One such factory was driven all the way from Earth to about 70° north latitude about two centuries ago. It operated for about a year before its crew met a mysterious and violent fate, though one apparently *not* caused by the Aeth. The damaged crawler, a factory/dormitory/warehouse the size of a football field, was left where it was immobilized. About a century ago it was taken over by a fringe Custom, who used the still functioning power system for life-support. This group abandoned the crawler several decades later when their leader died, and to the best of general knowledge, it remains abandoned.

The technological aesthetic of Terran society is both similar and different than what you, the gamemaster or player know and live with. On one hand, it is not a cybertech dystopia nor so advanced that things look radically different. Guns look like guns, phones look like phones, cars have four wheels and doors that open sensibly. There are no force fields or anti-grav and very few flying cars. Robots do not do everything because we simply cannot make them that sophisticated anymore.

On the other hand, the way things work is a little different. A city taxi has no driver and no controls. You enter your destination by voice or on a touchscreen, and it takes you there. But it works because it is wirelessly connected to CPU farm elsewhere, not because the car has the processing power to do it on its own. Most cars come with an autopilot link for use on the smart roads, and so even people who own cars might not really know how to drive them. High-density electrical power storage is the norm, good enough to meet the needs of everything except military aircraft. So, light-weight drones that can stay aloft forever are not uncommon as radio relays or camera platforms. Electro-active fabrics make for fashions that would be impossible in the early 21st century. Self-charging electronics are the norm, good bandwidth is presumed.

But limits on computer chips mean that there are no robots with near-human intelligence. In fact, the sophistication of electronics is *worse* than the early 21st century. The memory of your phone is only a few gigabytes, digital imaging sensors are only several megapixels, programmable or adaptable electronic devices are fairly stupid. You might have a drone that can stay aloft and observe things for days, but you have to use a telephoto lens to make out details, which means you may be missing something somewhere else. Plus, while the drone can fly a programmed pattern, it requires a human operator to do anything complicated. There are no hovering rockets, no tiny quadcopters flying in formation, no heavy-duty processing in the palm of your hand. Advances in tech that are noticeable are mostly in the form of energy, materials and medicine, all of which are significantly better than they are for you, the reader.

Basically, you *can* do a lot of cool things that you cannot do here on Old Earth, but almost all those cool things require that a person be involved in the process. So skilled people like the adventurers will always be in demand *somewhere*.

**Economy:** For a high-tech society, humans on Aethos have a fairly austere standard of living. Unlike 21st century Old Earth, there is no supply of ultra-cheap labor, and while there *is* significant robotics involved in *some* manufacturing processes, your clothing, computers and food are produced by workers getting the equivalent of 21st century United States wages. On the bad side, this means that something like a laptop computer or a pair of shoes costs more. On the good side, the stabilization of technology and better quality materials means these things last a *lot* longer. Human homes are not littered with useless gadgets, and closets are not packed with clothes that are never worn. *They are too expensive for that*. People generally have fewer possessions, and they try to take care of the ones they have. The *average* age of a Terran automobile is over ten years, and it is almost traditional for the first new car bought by a married couple to be given to their first-born when they reach driving age. The general durability of goods and the leveling off of technological progress means that many durable items are designed to be modular. A car might be a chassis that you can strip down and replace with all new body panels. You might claim to be driving your great-grandfather's car, even if the only parts remaining from his time are the frame and the dented and scarred body panels. A computer has parts standardized enough that you can simply replace parts that are wearing out. People may remodel their homes with modules other people removed from *their* home during a prior remodeling. You can go to a 'housing lot' and pick and choose additions like people would pick and choose a used car. Cut a hole in the wall of your house, pop in a prefab archway, bolt the new addition on, hook up the standardized utility connectors and *voilà!*, a new breakfast nook for the kitchen.



The workforce is divided about as you would expect for a modern industrial society. There are positions suitable for just about any level of aptitude or ambition, Service industries, resource industries, manufacturing, education, finance, government, etc. While many people do have a college education and literacy is near-universal, college-level training is not required for a good-paying job. An academic degree of some sort *does* raise the ceiling for most professions or make it easier for high-level advancement. However, lengthened human lifespans tend to pack the 'authority' jobs with experienced, senior people and turnover can be *glacially* slow. If your only chance of getting a tenure-track professorship is to wait twenty years for doddering old Wimblethorpe to shuffle off this mortal coil and then compete with the dozen other professors who have been waiting on the chance and collecting favors for ten years longer than you, you might just decide to screw it all and strike out with that exploration corporation that is headed off to sector Zeta-13 to assay the newly discovered ruins there.

**Ethnicity:** The 'external threat' that many perceived from other surface races shortly after the Exodus united the badly battered humanity into one 'nation' that called itself 'Earth'. However, for reasons lost to all but the Arkivists, humans call themselves 'Terrans', and this is the designation other surface races call humans by, within the limits of their vocal apparatus, anyway. There are still a few holdouts who refer to themselves as Terran-Americans and the like, but this is mostly an affectation of either rural rubes or snooty upper-crust types.

Most racial differences are extremely muted after a thousand years of interbreeding. There will on occasion be children born who have a marked resemblance to an extinct Earth ethnicity, but by and large humanity is *fairly* uniform in skin tone, build and facial structure, with the biggest variations being in hair type and color.

! Several subcultures have broken off from main stream humanity and 'gone native'. They have voluntarily regressed to a sustainable late 19th century level for most technologies, except for maintaining strains of advanced genetic medical phages used for regeneration, cancer therapy and so on. These groups typically migrate to less populated areas within their polygon or in an adjacent one, and set up agrarian communities. Their reasons range from ecological to religious, and they range from xenophobic to xenophilic (literally). They are not a military threat to any of the more advanced cultures because of their small size, but they are also seldom pacifists and are capable of defending themselves against bandits and often have militias equipped with obsolete but still deadly military hardware. *Obsolete or not, you would think twice about messing with the Amish if they had hand-cranked Gatling Guns and the will to use them...* Most of the communities will have a few radios or video devices for limited communication with the 'outside world', and depending on distance and trade routes, may trade raw materials and agricultural products in exchange for the things they cannot or will not make themselves.

**Religion:** Some of the human inhabitants of Aethos' surface understand that they do not understand and cannot understand the Aeth. Others do what humans always do when confronted with the unexplainable: *they make stuff up.*

Religion survived the Exodus. Maybe even a few of the original 21st century texts survived the past thousand years between the stars, but the *exact* nature of the faiths has not. Consider the teachings and doctrines of 11th century Christianity compared to that of the 21st century. A thousand years and a global cataclysm leaves room for a lot of new doctrinal interpretations, even if you are still calling yourself the same faith and basing it off the same source texts.



! Consider that if you are reading this in the early 21st century, then a mere two centuries ago, the doctrines of Christianity permitted the owning of slaves and the persecution of the Jews, and the justification came from an interpretation of the *same* scriptures that are used today. *So, consider realistically how much a 'rock-solid' faith might change after a millennium...*

The main faith among those who hold such is Biblism, which is mostly Christianity, with a creative spin on the Book of Revelations and the additional material of the 'Final Testament'. The destruction of the Earth is taken as the prophecies in Revelations. The Aeth are Satan and his devils, imprisoned for a space by God, to be released one more time after a thousand years, as mentioned in Revelations 20:4. The Final Testament was written by the returned Christ after the Exodus (that's the doctrine, anyway), and tells of a less peaceful thousand years than Revelations, but it converges with the release of Satan, a great and final battle, and then eternal life and human dominion of the universe.

Given what they do not know and do not understand about the Aeth, hardcore Biblists are going to be a real problem over the course of a campaign. The events prophecied in the Final Testament *are* coming to pass, and this is giving the Biblists a great deal of arrogance, power, and political influence. The response among Orthodox Biblists (including those in the Legislaat) to Aethos' deceleration is comparable to what you would expect in the 21st century United States if the government announced that it was going to require bar codes on the right hand and forehead of all citizens. That is, near-panic and an absolute, unshakeable belief that it was a sign foretold by divine prophecy.

More moderate or liberal Biblists are not so swayed, but they *are* Biblists and regardless of their opinions on the Final Testament, it *does* look suspiciously prophetic. Even the most heretical, who think the returned Christ was an Aeth-modified human, have to admit that the Final Revelation may have come from knowledge of the Aeth that only the returned Christ could comprehend and which he attempted to give to mankind as a warning.

Mainstream Biblism has its variants, much as 'Christianity' has Anglicans, Baptists, Catholics, Methodists, Unitarians, etc, as well as extinct sects, the Biblist equivalents of Gnostics, Manicheans and so on, some of whose texts or legends may be both useful to adventurers and heretical to Orthodox Biblists.

A subfaith that is much closer to Old Earth Christianity is the splinter faith generally called Old Biblism, or as its adherents call it, 'True Biblism'. It has the less accepted view that the Second Coming has *not* happened yet, and that current events are merely a continuation of history. There are many things unrevealed to men, and the Aeth are merely one of those things. Followers of Old Biblism are socially conservative and will not accept many of the more liberal **Customs** among their membership, and they are usually not as politically active as the main Biblist group. They would hold a position within the faith something like the Amish or Hutterites did on Old Earth, part of the faith, but separate from it. They have a good reputation and adhere mostly to a benevolent New Testament set of beliefs, though they are wary of outsiders and of being corrupted by outside influence.



What used to be the Muslim faith is now the Searchers. Only one part of the Middle East survived the passing of Earth, and only scattered elements of its culture. The Qur'an survived in its original Arabic, but in the first chaotic century after the Exodus, a pure knowledge of the Arabic language was lost. What remains of Arabic as a written language is not sufficient to *unambiguously* understand the entire Qur'an in its original Arabic. All that remains is the knowledge of the English transliteration and that only the partially unreadable Arabic version is the true Qur'an.

! We are not saying there were no survivors who had this knowledge. We are saying that the pressures of survival necessitated use of a common language (mostly English), and that over the first few generations, a pure knowledge of the core language was lost. Insular groups that refused to mingle or intermarry with outsiders or teach their children the language everyone else used, simply *did not survive*. There are a few who think the Aeth did something powerful and subtle to strip this knowledge away, but these people are generally considered crackpots and even the Arkivists do not pay attention to them. *Which convinces these people even more that the Aeth are involved*. This is actually a controversial enough point to build some adventures around. Someone comes up with some good math to show the knowledge could *not* have disappeared for the reasons history says it did, and then this person and their original research disappears...

So, each adherent of the faith is a Searcher, knowing the English version and as much as possible of the Arabic original, but seeking to understand the full truth of the original through a personal search. There are many elements that all agree on, but no formal doctrine, only interpretations and introspection. For instance, one must find their own personal Mecca to pray towards, since the original is gone. And how one determines what their personal Mecca is a matter of deep soul searching.

One belief is that the *kabba* survived and still orbits the Sun of the Old Earth, and that one should pray in that direction (towards Aethos' south pole), while another belief is that the fragments of the *kabba* are scattered over the surface of Aethos, and so any direction is acceptable, so long as the intent is pure.

The Searchers do not believe in the tenets of the Biblists. They see Aethos as merely the place of their Searching, and the Aeth the reason for the Search. Conservative Biblists do not like Searchers, but they are accepted by almost everyone else.

The last Earth faith to survive the Exodus is the Joodists, and they are not so much a faith as a way of thinking. The Torah suffered the same fate as the Qur'an, not enough speakers and writers of the original language to keep a full understanding of it. The most conservative of the faith simply did not survive the Exodus in large part due to stubborn insularity (they would not marry outside their own culture, and outsiders could not join, so they just went extinct). What *did* survive was the nature of rabbinic discourse. While Searchers are more introspective in their search for answers, Joodists prefer to argue the point with each other. And while the most skilled can recite huge sections of the Torah (in English), as an oral tradition there has been some drift in the actual meaning and interpretation. For instance, which of the edible alien species on Aethos are 'shellfish', or does an animal with three subfeet on each leg have a 'cloven hoof'?

Joodists have a belief about the Aeth that is closest to the truth, that they are forever beyond our understanding and so we should worry about more immediate concerns. The Aeth are merely a part of Creation that we share a path with for a while.



! It is worth mentioning that the greater the emotional investment a human places in a belief, the more likely they are to defensively back into a corner or strike out in anger when confronted with evidence that challenges that belief.

Religions, based as they are on faith and acceptance of things that are unknowable, are particularly susceptible to this, though adherents to accepted 'scientific dogma' can also become hostile if their beliefs are challenged (geocentric vs. heliocentric view of the solar system, asteroid extinction theory, plate tectonics, global warming, etc.). On Aeth, Biblists will be the most defensive of their religious belief, and those holding to the notion that Old Earth beat back the Aeth will be the most defensive on the secular side. These two will also be the most likely to engage in smear campaigns against their opponents or incite violent acts against their opponents with inflammatory rhetoric. In game terms, such a level of irrational belief is generally a Personality at  $\pm 4$  or more on their rolls regarding that topic.

This sort of behavior is not unique to humans, but other races on Aeth do not have it to the same extent. Whether this is because their cultures are just more mature or their genetic predisposition to this sort of thing is less is anyone's guess. *Why* it is worth mentioning is that matters of faith and possibly scientific dogma *will* play a role in the long term aspects of an Aethos campaign. Parallels to ultra-conservative or religious groups in the early 21st century are easily drawn.

In addition to modified Earth religions, there are some 'native' Aethan faiths, religious or quasi-religious beliefs that took root *after* Terrans arrived on Aeth. There are three of note.

First are Neogians, which is actually a linguistic variation of 'neo-gaians'. They are somewhere between Wiccans and environmentalists. They understand that the part of Earth that Terrans live on is measurably finite, in a way that people did not feel about the old Earth. They also understand that Aethos is an artificial construct. These two beliefs have combined into a notion that Aethos is itself a living and created thing, that the Aeth are not its masters, but merely its caretakers, and that the place of humanity is to be the caretakers of our own little part. Neogians believe that they can commune with Aethos itself and determine its wishes, use elements of semi-chance like Tarot to interpret Aethos, predict the weather, predict the appearance of the Aeth, and so on. The most fervent believers or communers claim and believe that they can communicate with and influence the Aeth and Aethos. Some, preying on human weaknesses, are charlatans, while others sincerely believe and think they have power to change things or make things happen. This is not necessarily mysticism (though some believe it as such), rather it is the feeling that Aethos is such an advanced technology that it might as well be magic, and use of tools like Tarot is merely a crutch to allow the conscious mind to accept and interpret the complex and subtle signals Aethos is constantly sending us.

The best (or worst) of each kind of Neogian are intelligent, perceptive and technologically savvy, but they are nonetheless seen by outsiders as kooks or witches or sorcerors. Maybe not in a 'burn the witch!' sort of way, but far enough from the standard Biblist orthodoxy to be occasional targets of hate crimes or angry sermons. Most Neogians are more casual about their beliefs and consider it more of a way of life or personal philosophy rather than a religion with an immutable central code. *The majority of the population considers Neogians harmless but wrong.* Neogian imagery is popular in jewelry and on clothing, even for people who have no interest in its teachings.





The Church of the Eschaton believes that the Aeth are technological angels, that the core of Aethos is a giant computer, and that the eventual purpose of Aethos is to collect all of the thoughts of all the sentiences that it encounters or that live upon it, to recreate them in an endless extropian reincarnation in the Aethan memory core, each life and lifetime evolving the person to a higher plane of virtual existence, until one is finally reincarnated in physical form as an Aeth. Once an Aeth, they collectively seek new races worthy of being enlightened and work towards the grand goal of surviving until this universe perishes, and passing through it whole into the one that follows.

This set of beliefs, like all good religions, cannot be disproved, has elements that make sense and appeal to a lot of human desires. *Whether any of it is true, no one knows.* Since they portray the Aeth as a positive force, albeit an unknowable one, the Church of the Eschaton is in direct opposition to Biblist beliefs. Terran statutes on freedom of religion protect the Church of the Eschaton, but in practical terms they are underground, and being a known member is generally a social stigma approximately the same as being an atheist in the early 21st century United States. You will not get stoned in the street, but it will make it difficult to gain or hold public office in the current political climate.

The last fringe group is Aethology. They believe that the coming of the Aeth was foretold in the mid-20th century on Earth by their prophet. He was mentally advanced enough to understand, albeit imperfectly, the impending arrival and purpose of the Aeth. This information he published and created a corresponding organization to promote, using a hierarchal system of advancement into the mysteries of the faith. The Aethologists believe that when the Aeth finally did arrive, they selected regions of Earth that had the highest concentration of proto-Aethologists to bring to Aethos.

Once humanity arrived on Aethos, some of the imperfections of the prophet's visions were revealed, but also the underlying truths. Humans were placed on Earth by the Aeth eons ago, knowing that it would take ages for us to evolve to a point worthy of being advanced enough for the Aeth to return. Unfortunately, only a tiny fraction of humans had sufficient potential, and the rest were forever left behind. The Aeth are seen as judges, who will give humanity but a limited time to prove their potential, before giving up on us and wiping us out, as they have other races that once dwelt on Aethos' surface.

Aethologists believe in strict mental discipline, an unyielding code of conduct and absolute loyalty to the faith. They sincerely wish all to join, but are relentless in their criticism of those who publicly oppose them. Members progress from lowly initiates up through various spiritual ranks, based on mental tests and their ratings on specialized electrical instruments designed to measure cognitive power and control of various brainwaves.

Aethology is held to by less people than the other fringe beliefs, but its adherents are much more fervent in their belief, and they have a small number of vocal celebrity supporters and a few mid-level politicians who are open Aethologists. While they are doctrinally different from Biblism and generally have contempt for 'superstitions', they share a common belief that the Aeth are ultimately going to judge or confront humanity, and because of that shared belief in the Aeth as an enemy, they will become reluctant allies once it is clear Aethos is decelerating into a new solar system. Both groups see this arrival as a possible confrontation point and both want humanity to be as ready as possible. The Biblists disagree with Aethologists on the reasons, but they do respect the mental discipline and insights of leading Aethologists. Neither side tells the other all their plans, but that is to be expected.



Aethologists are not *quite* fanatics. They are perfectly reasonable and rational, *except* on matters tied to their beliefs. On those, they will end friendships, marriages and disown children who stray from the faith, and are implacable enemies of any who have caused harm to Aethology.

In game terms, all of the religions can be modelled by some combination of the traits of Custom and Personality. The degree to which someone is emotionally invested in the belief will vary with Custom and the level in any Personality you would associate with the faith. An Orthodox Biblist with 'patriarchal-6' is going to be a lot less flexible than a Liberal Neogian. The gamemaster and players will need to work together to figure out what a particular faith is in terms of the specifics. Will your Biblist speak up when others use profanity in their presence? Does your Seeker insist that you pull over to the side of the road so they can pray? Is your Aethologist aggressively proselytizing? Does your adventurer eschew religion altogether, and if so, are they tolerant of faith, or dismissive or mocking?

**Language:** A mix of languages survived the Exodus, but in the end, something much like English is what came out on top. On Aethos, it is *the* human language. It is not *exactly* the language spoken or written on Old Earth, and adventurers trying to read ancient documents would be at a -1d penalty on skill unless they actually have 'Old English' as a separate fluency (costs 1S for those already fluent in 'Terran English').

**Culture & Government:** Terran culture is fairly uniform compared to that of Old Earth. Old national differences are gone except as matters of ancestry, and Earth has only one nation. The *ad hoc* system that barely got Earth through the first Earth-Cartoo War was replaced a century after Departure with the current system, which has worked passably well for the past nine centuries. However, it is creaking under its own weight and its slowly accumulated inefficiencies and flaws. Terran government is composed of an Executive, the Legislaat and Adjudicaat.

The Legislaat is directly elected by the States, three members per State, each member allowed up to two five year terms. A State is one chunk of territory that was transplanted to Aethos during the Exodus. Terran colonies in unoccupied spots of other polygons are represented by whichever State the founders of that colony chose to declare themselves part of (if that State agrees). There are currently nineteen States, thus fifty-seven members of the Legislaat. In the event a member leaves office, the runner-up in the previous election takes their place until the next election.

The Executive is chosen by a vote of the Legislaat, and is chosen from one of their number (the runner-up takes their place). The Executive is more or less a Prime Minister in a parliamentary system, but is harder to get rid of and has a bit more authority. The Executive is supposed to smooth out regional interests and conflicts, and has the power to arbitrarily decide the fate of any legislation that has a majority but does not meet the two-thirds majority (38 votes) needed for passage.

**i** A proposed law has 30 votes in favor. The Executive can declare it passed, or defeated. If passed, it becomes law. If it fails, that law cannot be brought to a new vote for the remainder of this year's Legislaat session.



Legislation is constitutionally limited to one topic at a time, and what a 'topic' is has been defined to minimize (but not eliminate) abuse. So, a military budget does not include tax law, and industrial oversight legislation does not include tariffs on goods from another polygon.

The 'one topic per law' and 'one attempt to pass per session' has its own set of exceptions and abuses and arcane parliamentary tactics, but it *does* function.

The Legislaat can replace the Executive at any time, but they need a three-quarter majority (43 votes) to do so. The Executive cannot rule on such votes. Replacing the Executive against his or her will is a fairly rare occurrence. The fairly high thresholds required for the Legislaat to get *anything* done mean that there is a manageable number of laws on the books. Unfortunately, some of those laws created bureaucratic regulatory agencies, which *have* generated quite a pile of regulations over the past several centuries, enough to support a private industry of 'facilitators', experts who will get your project through the regulatory system as fast as possible...for a hefty fee.

The Adjudicaat is the court system as a whole. The Supreme Adjudicaat is a five-judge panel that is the court of last resort. Each State has its own High Adjudicat with a three-judge panel, but there is no difference between state law and national law. It is all one set of laws, and all laws are passed by the Legislaat. There may be local customs, and local variations on how intently the laws are enforced, but there is only *one* set of laws. *The laws of your town are the laws of Earth.* If you do not feel the laws are enforced properly in your area, you can take the government to a local Adjudicaat to compel proper enforcement, and if the local Adjudicaat is biased, things can be appealed to higher levels, etc.

! The Supreme Adjudicaat handles mostly cases that had grounds to be appealed from State-level High Adjudicaats, of which there are one hundred and seven. The Supreme Adjudicaat simply does not have time to handle every last appeal, so many are referred back to the State level without comment, effectively giving *that* High Adjudicaat the ability to set precedent on the matter.

The enforcement or management of legislation and regulation is handled by several dedicated bureaucracies whose heads are chosen by the Legislaat, with possible veto by the Executive (veto of a candidate means that an alternate candidate must be chosen, not that the position remains vacant).

Individual localities have their own town or city councils and local Adjudicaats, but there is only a minimal State government. States have a High Adjudicaat, a State Police that is just a specialized branch of the Terran Armed Forces, appropriate offices for permits, government services and government-run entities, and the necessary bureaucracy to manage these, but that is about it. There are no State-level legislatures, but there are State-level bureaucracies to help manage problems at a city or town level (permits, etc.).

This government model worked fairly well for the first few centuries, but as the Terran population has increased, it has put strain on the lower tiers of the system. There are only three levels of Adjudicaat (local, State, Federal) for a population in the hundreds of millions. Local branches of things like the Postal Service are managed directly from the central government, and local branches of the State Police report directly to central government (though this is usually through the branch of the State Police in the largest city of that state). The State Police has elements of both the police and a military reserve. In the event of a surprise attack by someone like the Cartoo, the police are already in an area, know the area and have access to light military hardware.



However, the lack of an intermediate-level authority between local police and the central government concentrates a *huge* amount of power in central government, and requires a dense enough bureaucracy to manage it that sometimes important matters get lost in the shuffle. Think of the problems if every small town police department had to do its hiring through a bureaucracy in the capital. *The system works, but just barely.*

The most important thing to remember about Terran government is that it has existed as one system for nine centuries, longer than any Old Earth government of comparable size. It looks good on paper and it *mostly* works, but it is a wheezing monstrosity groaning under its own weight, too big to replace and with too much inertia to change its course with any speed. If it were not for the outside pressure of being surrounded by aliens and having nowhere else to go, Earth would have surely dissolved into civil war or worse by now. The added stress and chaos of the Arrival will almost certainly cause the Terran system of government to snap in one or more places. The questions will be 'where?', 'how bad?', and most importantly, 'what will step in to fill the breach?'

The future of humanity over the course of a campaign will be determined by humanity's own actions, and *this* is where the players and adventurers come in.

**Law and Custom:** There is a fine but genuine legal difference between law and custom on Earth. This difference is in many ways a safety valve that has kept the top-heavy central government from being so onerous as to be rebelled against. A 'Custom' is a legally recognized aspect of Old Earth culture that a person has chosen to adopt as part of their identity. There are quite a few of recognized 'Customs' from Old Earth that are given a special status. If a person is officially aligned with a Custom, this may constrain them in certain social ways, but also grants them certain exceptions to the law.

For instance, the casualties in the first Earth-Cartoo War were predominately men, and in the following century there was an unspoken acceptance of polygamy. Enough records of Old Earth survived to prove that this was a Custom, as part of one or more religions or time periods. While most people are *not* polygamists and the laws regarding marriage are written with monogamy in mind, polygamy is an official Custom.

A person who is a registered Polygamist may be part of a marriage with more than one other person, something that is illegal for the population at large. However, Polygamy as a Custom has its own rules regarding divorce, custody of children, alimony, etc., and these rules supercede normal law as well. *So, one cannot claim any benefit of a Custom without also being bound by its limits.*

Customs are not necessarily exclusionary and a person can hold to more than one Custom. One could be an Orthodox Biblist Polygamist, a Rastalectual Aborigine, or a BisexoCapitalist (you can legally sleep with anyone for money).



While almost all of these are inaccurate portrayals of some aspect of Old Earth culture, those who hold to Customs generally do so because it is what they *genuinely* believe in, and it is *their* way of keeping the Old Earth alive. That it gives them some freedoms regarding that belief that they would otherwise not have is certainly a measure of their appeal, too. Customs take the place of political parties in terms of power blocs, and virtually every member of the Legislat has one or two Customs that tend to represent the beliefs of their constituency.

**i** One state might have a Conservative Biblist stance, while another could be Conservative Intellectual. The two might vote together for an Executive that was Conservative, oppose each other if the proposed Executive was Biblist or Intellectual, and both vote against a proposed Executive who was Liberal.

This often makes Earth politics a matter of overlapping Custom loyalties and shifting alliances based on the legislative matter in question.

Customs can flaunt certain laws, but not all of them. A Custom will not let you kill people with impunity, evade taxes, steal, vandalize or generally cause direct or indirect financial damage. A list of some of the Customs and their effects is in the **Adventurer** creation chapter.

Adopting a Custom is a *serious* legal matter, and while it has no cost aside from a trivial processing fee, it *is* a very legally binding arrangement. You cannot adopt a Custom unless you are an adult capable of entering into contracts, you cannot change Customs more than once every five years and you cannot have more than three Customs. If you change Customs, you are legally bound to all commitments made under the previous Custom, or subject to any penalties associated with violation of the Custom.

**i** If you have multiple wives and stop being a polygamist, you have to give up all but one of them, and by *polygamist* law, this is a divorce where *you* are at fault and anyone you divorce will get half of your property or their share of the jointly held property, whichever is greater.

**Overall society:** Earth has a fairly standard capitalist economy with a number of socialist aspects to the central government. Basic and catastrophic health care is available to all at no charge (except that of the regular tax burden), but with a lifetime 300,000 Eur limit. When you spend the last of it, any health care is out of your own pocket or is paid through supplementary insurance plans with premiums based on your age, physical condition and profession. Secondary insurance coverage is *not* guaranteed. Some people are deemed poor economic risks, regardless of their ability to pay. Anyone serving in the military has their health care needs paid for by the government during their term of service. A side effect of this is that the longest average human lifespan is among career soldiers. *That is, if you have a 300,000 Eur medical policy and you do not even start using it until age eighty or ninety, it goes a lot further.*

Emergency care is always provided and reimbursed by the government, even if a patient has exhausted their medical allowance. *No one bleeds to death on the street because they cannot pay an ambulance.* Similarly, hospice care and painkillers are provided for those who can no longer be helped, whatever the reason. The system cannot spend a fortune on heroic measures for everyone, but it does have the compassion it *can* afford.

Speaking of which, there is no mandatory retirement age. Those jobs which require exceptional reflexes tend to be outcompeted for by those below age fifty. Exceptionally demanding physical jobs start to weed people out by age sixty. Those which require above average reflexes tend to stop around age eighty. Skills requiring sheer intellect tend to fade by the age of one hundred twenty.



People work until they choose to stop working or they are no longer able to work. Pension plans are voluntary, and employers may augment them or add health benefits as a perk to attract higher quality people. Government assistance to provide a minimal standard of living is available to all at age eighty, and the assistance provided comes from a fraction of the invested lifetime tax earnings of that individual, so the cost to the government is minimal and unlike many such plans on Old Earth, the pool of money cannot be used by the legislature as collateral for loans. The tax rates, benefits and such are fairly stable and self-supporting, and have been in place for several centuries, so the people working the budgets for these have a pretty good idea what they are doing.

! Every century or so someone comes up with a new way to embezzle or divert money out of this pool for personal gain. There is a big scandal, an execution or two, the loophole is plugged and things go back to normal.

There are the equivalent of unions, but they play a much less important role in things. The economy is fairly stable, and with stable prices on goods, income does not need to have constantly adjustments for inflation. Similarly, tech stagnation means that most issues of workplace safety were resolved centuries ago, and obscure Customs involving duelling and honor make sexual harassment a dicey proposition.

There is a flat fifteen percent tax rate on all transactions and commodities, with a few exceptions like weapon transfers (this is assumed in the prices in the gear listing). This tax pays for all government services. If the Conscription Laws are invoked, the tax rate automatically goes up to twenty-five percent for the duration of the Conscription and until five years after it ends. *It is simply coincidence that this automatic tax increase means that no legislator can be accused of voting to increase taxes.*

**Laws:** The Terran legal system is reasonably fair and has high standards of evidence for conviction of major crimes. There are still plenty of people who get away with serious and violent crimes, but advanced forensics does a good job in keeping innocent people from being convicted in any crime where there is trace evidence recovered. There is a government DNA database on just about everyone, but the relative ease with which genetic manipulation can be done means that genetic evidence alone is *insufficient* for a conviction (you can easily clone a stranger's DNA and leave it at a crime scene, or with some work, clone a whole hand and leave fingerprints). DNA evidence may be sufficient for a search or tracking warrant, but not for an arrest except in the most obvious of cases.

As a result, old-fashioned detective work is often more useful in solving crimes than high-tech wizardry is. Fingerprints, DNA and photographic evidence are only circumstantial evidence in Terran courts, often insufficient on their own to get a conviction.

The principle of the law is not 'innocent until proven guilty'. If it were, suspected murderers would walk free until convicted. It is a more practical and subjective 'you are guilty if the officer investigating you thinks you are guilty, and then you have to prove to the court that you are not.' So, having a useful layman's knowledge of the law and being reasonably polite to the police can go a long way towards avoiding problems. However, neither of these will do you any good if you are caught trying to manhandle a flatscreen TV into your van outside the broken glass and blaring alarms of an electronics store.



There is no 'corporate shield' in Terran law. Actions resulting from human action have human civil or criminal liability. This means that corporate CEO's or boards are ultimately *personally* responsible for the actions of that corporation, though clearly, individual actions by lower level employees are the responsibility of those employees and *not* the management. So, if a company truck driver illegally dumps industrial waste into a marsh somewhere, that driver is the criminal.

If that driver was ordered to do the dumping by someone higher up (and can *prove* it), then *both* are criminals. If the company is shown to have a culture of breaking environmental laws or regulations, then the CEO and board would be criminals, and the corporation a tool used in the crime. The individuals would be tried as criminals, and any ill-gotten gains would be taken as fines on the individuals *and* the corporation's bank account. Terran law, though flawed, believes very strongly in individual responsibility for your actions, and this is a concept that cannot be proxied, signed away be shielded from or evaded with a statute of limitations. If you do something wrong, being ordered to do it by someone else just means that *both* of you are guilty. This may not make people any more ethical, but it *does* make them more careful. If you are going to break the law for someone else, you want to make sure that they are going to be implicated too, or that at the very least they are going to cover your legal expenses and fines for getting caught.

Because adventurers are likely to run afoul of the law, some game mechanic details are in order. The law distinguishes between 'civil infractions', which are usually violations of regulations or crimes that are non-violent and non-destructive, and 'criminal infractions', which are usually activities that put property or people in danger or threat of danger. So, 'trespass' might be a civil infraction, but 'breaking and entering' would be a criminal infraction.

Within this, Terran law assigns a point value to each sort of offense or adjustment to an offense. If the total is at or below a certain threshold, the crime *can* be excused at an officer's discretion "I am letting you off with a warning...". The officer does not *have* to give a warning, but if in their professional opinion there are circumstances where a warning is sufficient, they have that ability. A warning almost always includes restitution of any damage done by the offense, and often a punitive amount of the same level to any aggrieved party. The officer may not collect any form of restitution on a warning, and the system is designed to avoid bribery by the offender or petty extortion by the officer.

Above this, a citation *must* be issued. This means that the offender either has to go in front of a judge at a scheduled date (usually set a few weeks in the future) or pay a pre-determined fine, either in person or electronically. If the citation is for some sort of illegal possession, the item is confiscated at the time of the citation, and would be returned if the accused is found *not* guilty of the offense (that is, possession was not actually illegal at the time the item was seized). Otherwise, they pay the appropriate fine *and* lose the item confiscated.

If the threshold exceeds a certain amount, arrest is *mandatory*. The suspect is detained, restrained (handcuffed), informed of their legal rights and transported to local jail for processing. DNA, fingerprint and retinal scans are taken and compared to investigations and warrants at a national level. The suspect and any legal representation they have then go before a judge, who determines if bail is appropriate and the amount. If bail is paid, the suspect is free to go, sans any possessions that were illegal at the time of the offense, and is expected to return to that court for trial at a later date.



For determining the value of a multiple offense, you take the biggest value and add +1 for each additional offense. Modifiers and conditionals are always at full value.

point scale for action taken	total
points for 'warning at officer's discretion':	≤2
points for citation:	3-5
points for mandatory arrest:	≥6

point scale for some offenses	value
trespass(land or untenanted buildings)	1
breaking and entering(active structures)	2
vandalism/superficial property loss	2
arson/malicious property damage	6
petty theft/fraud(less than 50 Eur)	2
theft/fraud(less than 1000 Eur)	4
major theft/fraud(more than 1000 Eur)	6
assault(non-lethal or half-lethal damage)	2
mayhem(lethal damage)	4
manslaughter/negligent death	8
murder/attempted murder	12
public disorder	1
public discharge of a weapon	2
possession of illegal non-weapon	3
possession of illegal weapon	4
possession of prohibited tech	6
dissemination of prohibited information	6
minor manual violation of road statutes	1
manual vehicle use under the influence	6

#### modifiers

in possession of a legal weapon	+1
in possession of a larger-than-legal weapon	+2
in possession of tools to facilitate the crime	+2
conspiracy to commit offense	+1
leading conspiracy to commit offense	+3
accessory to commission of offense	-1
inadvertent offense	-1
offense as defensive response/self-defense	-2

#### conditionals

prior warning for same offense	+1
prior citation for same offense	+2
prior arrest for same offense	+3

The 'conditionals' category only applies to the officer's immediate response to the infraction, and does not affect bail or sentencing. So, if an officer arrests you for something just because you are caught doing something you have a prior record for, it does not affect your punishment for the crime, it just reduces the discretion the officer might have to merely warn or cite you for it.

**i** If you were simply crossing someone else's property in violation of posted signage, this would be a value of 1. If you were carrying a legal weapon, this would be a total of 2, so if the owner called the police and they decided to have a chat with you, they *could* let you off with a warning *or* cite you. If you had a prior warning or citation for that offense, the total would be at least 3, so the officer would *have* to write you up for it.

**i** If you entered an actively used building(2) and sprayed graffiti(+1), had a prior arrest for it(+3) and got caught, the total would be 6 and the officer would have no choice but to cuff you and haul you in for processing.

If you are cited for something and simply pay the fine, the matter goes away. You may have lost any illegal possessions involved, but it is counted as an acquittal in some ways. Anyone accessing the record finds it is tagged 'no contest', which is neither an acquittal or conviction. It simply means you paid the fine without contesting the charges, and it does not show up as a prior citation for the conditional modifiers. If you contest a citation, it is handled by a trial process. Another advantage of simply paying the fine for a citation is that the amount of the fine is reduced by a flat 50 Euros. This is because there is no court time involved in the case, and not coincidentally, the reduced fine means that people are more likely to just grumble about the government and pay it.





Determination of guilt or innocence in court is fairly important, and something adventurers can be expected to deal with at some point in their careers. You can note that the back of the **Aethos** adventurer sheet has a spot for their record of warnings, citations and arrests. It would be nice if the system was simple and straightforward, with the innocent swiftly being vindicated and the guilty getting convicted, but it is still not that simple. In game terms, a trial would be a semi-adversarial skill contest between the prosecution and defense. The prosecution is trying to match or beat a difficulty based on the severity of the offense the suspect is charged with, while the defense is trying to do the same.

The base difficulty is twice the value of the primary offense. The prosecution reduces their difficulty by any positive conditionals, and the defense reduces their difficulty by the value of any negative conditionals. If the accused is actually guilty of initiating the chain of events that led to the offense, the difficulty for the prosecution is reduced by 3, and if the accused is actually innocent, the difficulty for the defense is reduced by 3.

**i** An adventurer is accused of manslaughter because they killed someone in self-defense in a public square with their legal weapon after being attacked. The base difficulty for this crime is 16 (twice the manslaughter value). The prosecution drops their difficulty to 13 (by 2 more for the public discharge, and 1 for possession of a legal weapon in commission of a crime. However, the action was a defensive one, so that defense gets a reduction of 2 for the defensive action. In addition, the adventurer did not start the situation that led to the death, so they are 'not guilty', and reduce this by 3 more, to a difficulty for the defense of 11. The prosecution just uses their value of 13. So, the counsel for the defense tries to beat a difficulty of 11 by as much as possible, and the prosecution tries to beat a 13 by as much as possible.

You can see how circumstances can make things easier or harder for adventurers in these situations. For instance, if the adventurer had disabled their gun camera and there were no witnesses to the shooting, the adventurer would still be 'not guilty' and the charge for public discharge of a weapon might be dropped, but there would be no way to prove that the action was genuinely self-defense. A prosecutor with an axe to grind (or as an Enemy) might try to up the charge to murder instead of manslaughter. This would increase the difficulty for both sides, but would also increase the severity of punishment for guilt.

**!** The previously mentioned legal immunity for using a 'legal weapon' to stop a crime is not a blanket assumption that the police just grant you. It is a determination made by the courts as part of an acquittal. The -2 to the target number for the defense because you acted defensively or in response to another situation is the legal presumption of your legitimate intent, and one reason most holders of legal weapons leave their gun cameras set to activate the instant the weapon is drawn.

Given the difficulties and skill rolls, there are several possible outcomes.

- if one side's legal counsel can get a success by 'taking 2's' and the other cannot, then that side wins the trial, regardless of what the other side rolls.
- if both sides roll, the side which beats their difficulty by the most wins.
- if both sides roll and beat their respective difficulties by the same amount, the defendant wins on a technicality.
- if both sides roll and neither side reaches its respective difficulty but the prosecution is closer, the offense is reduced in severity until the prosecution succeeds. The offense would be reduced to the next lowest related type, which could result in a significant drop in offense severity.



Acquittal is pretty easy to relate in game terms. The court finds you not guilty *and* not liable in any civil sense. Any possessions confiscated are returned, and all information relating to you and this case is immediately tagged with 'acquitted', meaning that the event (including the arrest or citation) does *not* count towards any conditionals for future offenses of that type.

**i** Let's apply these criteria to the previous example.

- The first case would be if the defense had a skill roll of  $5d+1$  or more and their prosecution had a  $6d+0$  or less. The defense could 'take 2's' and win automatically.
- The second case would be both sides rolling. With a three point advantage, odds are very high that the defense will win, but it is technically possible that the adventurer could be convicted of manslaughter or some charge of excessive force in a self-defense situation.
- The third case would be both sides beating their difficulty by the same amount. The adventurer would be acquitted, but it would be clear from the trial record that it was due to procedural mistakes by the police or prosecution.
- The last case is highly unlikely in this particular example, but possible. Say that the defense rolled a total of 8 and the prosecution a total of 11. So the defense failed by 3, the prosecution by 2. The severity of the offense would have to be dropped by at least 2. Looking at the table, the closest item to 'manslaughter' is 'mayhem', so the adventurer is convicted, but on the lesser charge of mayhem instead of manslaughter.

One thing that has not been mentioned is the cost of legal counsel. If you have no money, an overworked public defender takes a marginal interest in your case and will defend you with a  $3d+1$  skill roll ( $4d+1$  actual skill, but they do not have the proper time or initiative to give your case their full attention). If you use your own legal skills to defend yourself, you do so with a  $-1d$  penalty. Terrans are assumed to have enough cultural knowledge of their own laws to use their Awareness roll in their own defense (but with the  $-1d$  for defending yourself). Anyone can be hired to defend someone else in court. There are no 'you must be a lawyer' rules prohibiting this. However, it just makes sense that if you can, you hire a professional in *that* field. *You do not hire a carpenter to fix your plumbing.*

If you hire a legal professional, the hours spent in preparation, investigation, discovery and trial will probably set you back a money level of  $-8$ , *plus* the level of the primary offense the prosecution is rolling against, plus 1 for each die or fraction of a die in your defender's skill roll.

**i** Let's say our adventurer wanted a lawyer with a skill roll of  $5d+0$  to handle their case. Starting with a money level of  $-8$ , you add the severity of the offense (8) and the skill of the lawyer (5), to get a legal bill of  $+5$ , or 5,600 Euros.

The Terran legal system does *not* provide reimbursement for legal expenses on acquittal in *criminal* cases. In *civil* lawsuits, a successful defendant may petition for reimbursement of legal expenses, and a successful plaintiff may automatically claim *either* side's expenses in addition to the amount of the suit. Both claims are subject to *close* scrutiny by the court to avoid abuse, but it does make for some legal chicanery in asymmetric cases. An individual filing a civil claim against an extremely wealthy entity could lose and be bankrupted by having to pay the legal fees of the person they sued. But if they win, they can claim reimbursement of the *richer* person's legal expenses.



Punishment for crimes is fairly immediate and does not rely on extended incarceration except in the rarest cases. Despite a population of three hundred million, Earth only has several thousand long-term prisoners. Punishments are typically fines, either payable immediately or automatically deducted from any income you make. If you cannot pay a fine and refuse to work to pay it off, you are enlisted in the Terran Armed Forces if able-bodied. Refusal to submit to orders for someone in this case would be considered treason and would be punished by *execution*. The few executions that take place each year for this reason act as a deterrent for those who think they can stay in their old ways after being sentenced to military service. Those who refuse to work but are unfit for military service become 'paid' medical guinea pigs and make up a small fraction of permanently incarcerated criminals.

In game terms, fines are generally a money level of the *total* value of the offense (including prior convictions). At the lower end of the scale, this is probably a token fine plus a chunk of money collected by the state in the guise of 'court costs'. In addition to court-imposed punitive fines, restitution for property damage or medical care is required, and if you damage someone's earning potential or affect a family because of loss of a primary wage earner, then all of that has to be taken into account as well. Evasion of court judgements is *not* possible by declaration of bankruptcy. However, a court will not garnish wages past that which would drop a person to the official 'poverty level', and penalties only apply to the person convicted, not their family. So, it is possible that a huge judgement against you could negate most of your earnings for the rest of your life, but you could still live a life of luxury with a wealthy spouse. Or, your wages from a corporation could be highly garnished, but a 'company villa' that owned by someone else and merely provided to you as part of your employment would *not* be affected. You can see that the system is good, but *far* from perfect.

**i** Let's look at potential guilty verdicts against our technically innocent adventurer. The total value of the offense is 9 (manslaughter(8), public weapon discharge(2), use of a legal weapon in the commission of a crime(1), defensive weapon use(-2)). On a conviction, this means that the fine to the adventurer would be a money level of +9, or 23,000 Eur. Plus of course, a conviction record that could make things more difficult for them in the future. The lesser charge of mayhem would have made the total offense a value of 5, so the fine for that conviction would only be a money level of +5, or 5,600 Eur.

**!** An evil and manipulative gamemaster might use a system like this to railroad an adventurer who had committed a crime, with a 'friendly' military official on hand to offer them a way out of a punitive sentence. Which just happens to be by using their unique talents on an assignment no 'genuinely patriotic' citizen would turn down.

Convictions with a total value of 12 or more will *mandate* some sort of coercive legal intervention, either incarceration, behavioral modification or implants. In game terms, it will depend on what the offense was and whether or not the person has a history of that behavior. This could range from something as simple as a restraining order monitored by a tracking implant, or something far more complicated. For adventurers, this would be some combination of a government Enemy and a Personality trait that affects their decision making. The more severe the offense, the more severe the intrusion.

**!** Your lifetime medical benefit cannot be touched in legal matters. It cannot be used as collateral, transferred or used for any purpose except *your* personal medical expenses. So, you cannot pay a judgement for someone else's medical care out of *your* medical balance.



Convicted criminals may be 'tagged' with tracking devices, either implanted or in more serious cases, directly interfaced with their nervous system. Extreme punishments can result in genetic modification and behavior modification. This is nothing visible, but alters the DNA of the person to enforce the decision of the courts. A person at risk of flight could have their DNA altered so that they require a special injection once a week to avoid weakening and dying. A person who violates restraining orders could be conditioned to violently vomit every time they see or hear the person they are ordered to avoid. A compulsive shoplifter could be conditioned to be irrationally afraid of stores, or a murderer could have their brain modified to constantly produce calming chemicals. These are not perfect solutions and are considered 'last resort' options. Being on some form of 'probation' is a **trait** you can have as part of your adventurer.

The duration of *any* punishment is based on the crime and the criminal. The most severe or invasive sentences are the longest, and *can* be for life. As a note, incarcerated people use their *personal* medical allowances for care, so try to avoid frequent shankings.

The system is not perfect, but it is better than locking up the criminal at taxpayer expense for decades. Add in the fact that a large percentage of the population both carries a firearm and is legally immune from most consequences of using that firearm to stop a crime, and Earth's crime rate is exceptionally low. The down side is that when a violent crime occurs, it can be exceptionally violent. A mental imbalance that results in a mass shooting happens on average once every few years.

! Most of the legal system notes relate to the sort of things adventurers would be involved in, where the police are there at or shortly after the time the offense takes place. A deeper level of legality involves cases where a crime or criminal activity is merely suspected of having taken place. *Is someone manipulating the stock market? Is a 'suicide' actually a murder?* In these cases, detectives have to do the legwork and track down clues to get enough evidence for an arrest warrant to be issued. The actions of adventurers could contribute to this and they might be witnesses in any eventual trial, but since the adventurers are not likely to be government or police investigators, the *details* of this sort of activity can be abstracted into the plot. Like "*this case will fall apart if this witness disappears*", or "*this memory chip has information that ties the ringleaders to the low-level operatives who actually did the dirty work.*" You do not need game numbers or skill rolls, you just need to deal with the matter at hand.

**Legal Weapons:** Earth citizens have a very strong tradition of weapons ownership. While input from areas of the United States imported to Aethos was certainly a factor, the *main* reason is that Earth was at war with the Cartoo on and off for several decades after humanity arrived on Aethos, and the Cartoo do not have a word in their language for 'non-combatant'. Having a weapon and having it in reach at *all* times often meant the difference between life and death. This was made part of the first Terran Constitution and has since remained, nearly as strongly held as any sacred writ. All free citizens may own and carry weapons, either openly or concealed.

While one does not need to have passed basic marksmanship classes to carry a legal weapon, the liability issues for causing harm if you use a weapon without proper training are such that most people who cannot or do not want to pass a basic marksmanship class are also unlikely to want to carry this sort of weapon.



There are three sets of restrictions on carrying legal weapons.

- **criminals:** Anyone convicted of a violent offense with a weapon will have a 'weapon sickness' implant for the duration of their sentence. This will incapacitate the person if they so much as pick up a registered (i.e. RFID chipped) weapon. This can be negated or avoided, but it is there as a reminder to the person that the courts *can* take even stronger measures if they have to.
- **place:** Any private residence or business may prohibit open or concealed carry, but *must* have safe and secure weapon storage for visitors and *is* financially liable for the weapons while in storage, *and* legally liable for the defense and defense-related medical expenses incurred by a visitor who was deprived of their weapon when they needed it. An exception exists for luggage-free commuter transports, which may have any civilian 'no weapon' policy they want. In addition, weapons must be surrendered before entering any area dedicated to the executive, legislative or judicial branches of government (which includes temporary or permanent lodging of its members), but the government is *only* liable for the safe-keeping of weapons.
- **type:** The most important restriction on weapon ownership is the notion of a 'legal weapon'. This is any weapon with a muzzle energy of 600 Joules or less that only fires one shot with each trigger pull. This is deemed sufficient to incapacitate a human or other races in this polygon, but is not threatening in a military sense (you will not be taking on tanks with it). These weapons have the natural side effects of their type (lasers are quiet, etc.), but they may not be modified to militarily enhance them, so you cannot legally use hand-loaded or armor-piercing ammunition to subvert the *intent* of the legal weapon guidelines.

Legal self-defense also includes permission to own body armor. The maximum protective ability is not limited by law, but use of body armor to evade harm from legal self-defense *is* a crime. A weapon legal for a Terran citizen to own is required to have an embedded RFID chip (armor does not have this requirement).

A weapon that is certified as a 'legal weapon' by the government is in a standard database and law enforcement officials do not even blink at people carrying them. Note the difference between 'a weapon that is legal to own' and a 'legal weapon'. It may be legal to *own* a fully automatic gauss assault rifle, but *not* legal to carry it around with you without a special permit. A 'legal weapon' is legal for anyone to carry, no questions asked. A mother at the market with a toddler will notice someone with a laser pistol on their hip only to the extent they tell a grasping toddler "*Remember what Mommy said? You **never** touch other people's weapons.*"

Carrying an otherwise legal weapon without an RFID chip is a crime, and any person who wants one can buy an RFID scanner for legal weapons, which will indicate the presence, direction and distance of nearby legal weapons (within several meters). Similarly, anyone can buy a portal scanner that will electronically sniff for the presence of concealed firearms by either their metal content or trace emissions of their circuitry (lasers or gauss weapons) or their propellant (conventional guns). The ready availability of these two detection technologies makes it very difficult for a person to walk around in well-developed urban areas with an un-chipped firearm without drawing the attention of the state police. There will be 'bad parts of town' where this is less of a problem, but travel outside these regions with the un-chipped weapon could be difficult.

Note that 'legal weapons' are not always pistols. Light rifles, carbines or shotguns can all be legal weapons as long as they meet the muzzle energy and 'semi-auto only' limitations.

**!** Yes, there is a black market in RFID chips that will pass remote querying, so a person can carry an untagged firearm with an easily removable chip in case they want to carry an unchipped weapon.



This does not imply that 'legal weapons' are the only ones allowed to people. They are merely the ones that are extremely common and which have the most legal protections. Heavier weapons and even autofire weapons are available to any adult without a criminal background that would prohibit ownership.

More powerful weapons require a purchase permit and a transfer tax for new or used purchases, the tax being graded on the threat level of the weapon. A hunting rifle might have a tax of ten percent of its new value, while an assault rifle might be taxed at fifty percent of its new value *each time it changes hands*.

The government can and does place limits on the transport and carry of heavier weapons, and individual states or cities may have their own restrictions. However, as for legal weapons, any entity prohibiting them must accept liability for storing and returning them, and legally registered weapons can *always* be legally transported from one legal storage location to a legal use location and vice versa, though the law might require the weapon be in a locked container for transport.

**i** Philadelphia has strict rules on autofire weapons, but cannot prohibit their private ownership, nor prevent the weapons from being transported from a private residence to a shooting range out of town. They can, however, require that for any transport on a public road, the weapon and its magazines have to be unloaded and stored in a locked carrying case.

**!** Everyone on Earth is *not* packing heat. *Not by a long shot*. While a large majority of people are qualified to carry a legal weapon, it is extra weight and occasional inconvenience and most people will never need to use it. Most people will go through a phase where they carry a weapon a lot, but eventually it gets relegated to the glove compartment or the nightstand or for when you want to go out for a midnight walk. So maybe one out of twenty people on the street is *actually* carrying. That's still a *lot* of guns on the street.

Earth-wide permits that circumvent local law exist only at the governmental level (State or Terran law enforcement). Individuals like bodyguards who want or need to carry weapons heavier than legal weapons have to go through the permit process for *each* restricted location they want to carry the weapon in. Being hired by someone influential no doubt helps. Such permits are usually issued for five year durations and can be renewed without having to go through the approval process again. More powerful weapons like anti-tank rockets or grenades are handled the same way, but purchase permits are more strictly controlled and based on perceived need and ability to use the weapon. A farm on the Cartoo border that is owned by an ex-Marine is more likely to get a permit for a surplus tank than is a housewife who lives in a central State. In general, retired military personnel can get obsolescent or surplus weapons for personal use (not for resale) at a fifty percent discount. Some well-off veteran officers who live near the Cartoo border have their own unofficial militias, complete with armor and anti-tank weapons! Of course, most of the soldiers in these militias are retired servicemen and women in their eighties and older...

**!** A minor exception to the legal weapon laws is that someone whose Custom is an Aborigine may carry primitive 'legal weapons' like spears or bows without RFID chips, even if these archaic weapons are made of advanced materials. However, unless conscripted, Aborigines may not get permits to own anything *more* powerful than a legal weapon.

**!** The notion of 'legal weapons' fits with the history and culture on Aethos, but it is also unashamedly a deliberate inclusion so as to give a way for adventurers in fairly high-tech and population dense gameworld to cart around weaponry with little hassle, something you would not see in *any* near-equivalent 21st century Earth culture. It also means that in the event of invasion (or civil war) there will be a lot of well-armed and well-trained factions already in place.



The very notion of 'legal weapons' or a heavily armed civilian population is going to be a contentious one during an **Aethos** campaign. The last Earth-Cartoo War was long enough ago that no one alive remembers it. Most of Earth's population is urban and not near the quasi-militarized border with the Cartoo, and the vast majority of people allowed to carry legal weapons do not do so with any regularity. So, some political alliances are forming with the idea that these notions are part of our violent past, and that civilized people do not need to hold to such antiquated notions. We are going to be contacting a new alien race, an entire planet of sentient beings. *Do we want the first impression of us to be as a bunch of violent, gun-wielding savages ready to lash out with violent force at the slightest provocation?*

On one hand, there will be people calling for complete civilian disarmament with limited exceptions for rural and frontier areas. On the other hand, there are people suggesting that the Arrival is going to make the world more dangerous and that surplus full-auto military rifles should be made freely available to any teens who get an 'A' in marksmanship. Very few sensible voices are in the middle, and most of those are leaning in favor of *more* restrictions, like legal weapons have to be kept locked up in home or vehicle, and have transponders that alert the police automatically if they leave these secure locations.

*"Sir, we have indication that your registered pistol has been removed from the glove compartment of your vehicle. Is there a problem we should be aware of?"*

Given the propensity of adventurers to get into gunfights, sometimes in populated areas, the actions of the adventurers may play into this debate and make them whipping boys or spokesmen for one or both sides of the issue, depending on whether their actions saved innocent lives or *cost* innocent lives.

**Other legalities:** Earth corporations and real estate *must* have majority Terran ownership. Other surface races can work for or be part owners of any Earth concern, but are bound by Earth law in their personal and business dealings. The only possible exception is diplomacy. The notion of a separate 'diplomatic status' is not unique to Terrans, it is just a common-sense approach to dealing with differences in culture and a protection for diplomats. Within small and strictly defined diplomatic missions, the law of the surface race running that diplomatic mission applies to members of *that* surface race. Members of other races that might be part of a diplomatic mission have a mixed status. Law enforcement of the host nation must go through their own government channels to get permission to serve warrants on diplomatic property.

**i** The Drinn diplomatic mission operates under Drinn law for the Drinn working there. A Terran working there could be hired and fired according to Drinn law, or arrested under Drinn criminal law, but could not be extradicted to Drinn territory without Earth permission.

Similarly, upper echelons of foreign diplomats have 'diplomatic immunity' of varying degrees, and may not be searched or arrested. They *may* be detained until their diplomatic status is confirmed, but such confirmation must be done in an expeditious manner. As on Old Earth, if a diplomat is suspected of illicit activity, the worst that usually happens is that they are expelled.



Note that there is *no* diplomatic status between Earth and Cartoo. Neither side trusts the other enough to allow this. The Cartoo, Drinn and Tuaqq *do* have the equivalent of embassies in each other's territories. There are also a handful of floating platforms anchored on the 'border' in the central sea that are used for trade and diplomatic purposes. Humans and Cartoo also use merchant intermediaries as an unofficial line of communication (possible angle for the gamemaster to use in adventures).

**Conscription Law:** The Legislaat has the power to invoke a very old Conscription Law in order to boost the Terran Armed Forces. Anyone between the age of eighteen and sixty is eligible. This is *not* done casually, and is meant to mobilize the *entire* population that is not involved in a war effort. Selection is first done from the least disruptive sectors, such as the unemployed, unskilled or semi-skilled workers and non-violent prisoners, but by law all sectors of the population are represented in some proportion with each callup.

There *are* jobs and fields that are exempt from service, at least in some stages of a draft, and it is human nature the wealthy and well-connected seldom have to worry about being sent to the front lines, even if they are drafted. At the time Aethos fires up its main engines, the Conscription Laws have been unused for nearly two centuries, and an impending state of war is usually required for them to be invoked.

! Invoking the Conscription Law or even a serious discussion about it would be an important event in a campaign, even if just in the form of things that are in the news and being talked about. In a more personal sense, there could be people who are actively trying to manipulate events for or against the Conscription Law and these events are ones the gamemaster might be getting the adventurers involved in.

**Military:** The Terran military is generally known as the DF, or Defense Force. Training, ranks and deployment are specialized into land, air, sea, police and special forces. Earth has a total military force of about half of one percent of the total population, about a third of which are StatePol and most of the rest are Landforce. The number of surviving veterans capable of being a useful force doubles this, and the Conscription Law can multiply it severalfold.

The normal Terran military posture is defensive and distributed. The Cartoo have tended to be scattershot and uncoordinated, doing either hit-and-run or hit-and-sit attacks, depending on how they want to profit from the situation or what pressures they are under back home. So, the Terran military strategy is to have enough force and equipment at key spots to delay or blunt an attack long enough for reinforcements to arrive. The border areas are more heavily militarized because they are expected to be harder hit. The best description of the Terran policy is 'not one centimeter'. You do not give up *any* territory to anyone, *ever*, regardless of the cost. Because the Cartoo like to push and test, skirmishes are not uncommon.

In addition to normal infantry, armor, air power and a very small navy, the Airforce also includes a suborbital wing based out of Kathmandu. These are heinously expensive to deploy, but can get anywhere within a thousand kilometers (anywhere on Earth and then some) in fifteen minutes. Landforce also has some permanently emplaced railgun artillery in the hills of northwest Roanoke. These are suborbital cannon, and with guided shells can drop a high-explosive payload or bunker-busting kinetic penetrator anywhere within several hundred kilometers. Their location is well-known to the Cartoo, who also have such guns (*bigger* ones), which they used to hammer flat the buried submarine pens in Vladivostok during the third Earth-Cartoo War.





These are the Aethos equivalent of nukes. People do not use them unless the other side uses them first. The Cartoo have not used theirs since Earth built their own. Both sides have heavy defenses around these sites, but a suborbital kinetic penetrator does a lot of damage and is hard to knock off course.

! In real-world terms, a one ton chunk of *anything* falling from fifty kilometers up has a kinetic energy of 1,000 megaJoules, or 250 kilograms of TNT (assuming no air drag). The difference between this and a conventional 250 kilogram explosive charge is that the penetrator is doing better than Mach 3 when it hits. Conventional bunker-busters that are dropped from airplanes could penetrate ten meters of reinforced cement or thirty meters of soil, so the suborbital ones are *significantly* more formidable.

**Money:** Despite its immense age and general technological complexity, the surface races of Aethos do not have a unified communication network, data protocols or programming language. Part of this has something to do with national or racial pride, and partially because the surface races *think* differently and even when they copy much of someone else's tech, they adapt it to match their own preconceptions and needs.

This means there is no convenient electronic means to transfer money between races. There *are* such transfers, but they are in large sums after negotiations, by banks or businesses specializing in that sort of transaction. Within a surface race, electronic money transfers exist appropriate to the level of technology. Humans have a system similar to early 21st century credit cards, which provide credit (with a small interest fee) or draw directly from a Terran bank account. This is *technically* accessible anywhere a cell phone signal is present, but low-level interference from Aethos' main drive may play havoc with radio for quite some time and areas which previously had marginal coverage may have intermittent 'dead air'.

However, for casual, low level transactions, most commerce is handled by 'value currency'. That is, the actual items used as currency are *perceived* as having intrinsic value. Precious or industrial metals are used in denominations unique to each surface race. Gold, silver and copper are all useful to a technological species, and unless a race has just been transplanted by the Aeth, the amount of these metals in the economy is a fairly stable amount. Prospecting and treasure-hunting in the territories of extinct civilizations happens more frequently in video than in real life, but people have occasionally struck it rich (or come to horrible ends).

That which is lost from industrial processes or waste is slowly reclaimed by alltrees, smelted and put back into circulation. Alltrees are used as a remediation or cleanup strategy for some industries and most urban sanitation facilities are ringed with them just to extract rare elements that make their way into the system.

Samarium, ytterbium, niobium, cesium, rubidium and other useful trace metals are always in demand and can be used as inter-species currency for large value transactions unless the Terran government has put a hold on such transfers for strategic reasons. In addition, while it has no value to consumers, flakes or needles of scarth are also usable as a currency of sorts. As an item that holds an edge forever, they are embedded in a metal casting and used as industrial cutting tools, ultrasharp scalpels and such. Powdered scarth can be mixed with metals to make superior edges and in rare cases, specialty munitions.

The value of a given coin varies with race, but humans have standards based off an Old Earth money called the Eur.

10 grams copper = .1 Eur

10 grams silver = 1 Eur

10 grams gold = 100 Eur

1 gram scarth = 1000 Eur

(*scarth is only a commodity, not a currency*)



Coinage is issued in 10, 20 and 50 gram coins, except the copper, which is only issued in 10 and 20 gram coins, and the gold, which is also issued in a 5 gram coin. Coins are generally referred to by their metal for a 10 gram coin, 'half' for a 5 gram coin, 'deux' or 'deuce' for a 20 gram coin and 'cinco' for a 50 gram coin. So, a 20 gram copper coin would be a 'copper deuce', while a 50 gram gold coin would be a 'gold cinco' and a 10 gram silver coin would just be a 'silver'.

Coins are all the same size. Normal and half denominations are round with a hole in the middle. Double denominations have the hole filled in, and cincos are two-and-a-half times as thick. Different metals have distinctive ridges on their rims, making it easy to tell what a given coin is simply by feel (e.g. it is not thick, it has wide ridges and no hole in the middle, so it must be a silver deuce).

! In keeping with **EABA** standard currency, all prices will be listed in Credits, but a Credit is the same as a Eur in this gameworld and the term 'Eur' would be used by adventurers as a matter of campaign flavor. The exchange rate is artificially set to be fairly compatible with most other **EABA** gameworlds at this level of technology and industrialization, noting that some forms of tech are going to be more expensive because of resource scarcity.

Terran coin	value	weight	value per kg
copper	.1 Eur	10 gram	10 Eur
copper deuce	.2 Eur	20 gram	
silver half	.5 Eur	5 gram	100 Eur
silver	1 Eur	10 gram	
silver deuce	2 Eur	20 gram	
silver cinco	5 Eur	50 gram	
gold half	50 Eur	5 gram	10,000 Eur
gold	100 Eur	10 gram	
gold deuce	200 Eur	20 gram	
gold cinco	500 Eur	50 gram	

Most Terrans have wallets designed for easy storage of various denomination coins.

! Yes, gold is a bit undervalued. Aethos has proportionately more for some reason, dropping its scarcity-based value. Over the centuries, outside sources have paid Earth enough gold to offset its own internal shortfall of the metal.

! As a visual comparison, this means that a gold coin the size of a United States quarter would be worth about 110 Eur.

Surface races have different standards of metal purity for their coins, so there is not a perfect exchange between one race's currency and another, but in general, everyone accepts everyone else's currency. Cash registers can automatically apply any value difference just by running a coin through a scanner to identify it and check the current exchange rate.

! Counterfeiting is not much of a problem on Aethos. Crimes involving money typically involve theft or fraud, not debasement of the currency objects themselves. Making fake gold cincos is not likely. Creating a scam to give the illusion of a massive new gold discovery to depress gold prices and engage in some shady currency trading to profit from it is another matter...

The only major surface race that does not use precious or industrial metals as currency are the Ancients. They use an entirely electronic system within their culture, and a knowledge-based currency for everyone else. They have their own way of assigning value to knowledge they buy or sell, and it can be saved or traded like any other currency, in the form of uniquely ID'd physical tokens, each of which represents some amount of knowledge, referred to as a 'Quanta'. The only way the Ancients issue quanta is when they get information they want or need. When a quanta is redeemed with the Ancients, it is destroyed or its identity number is purged from the system, similarly reducing its value to zero. So, the quanta issued by the Ancients are available on the markets of other surface races, meaning that you can spend real money to acquire enough quanta to get an answer to a question (or pay your hotel bill while in Ancient territory).



Things the Ancients are always interested in, assuming it is *new* knowledge:

- knowledge about the Aeth
- knowledge of extinct races
- knowledge about a system being approached
- knowledge of anyone's military preparations
- knowledge in scientific fields the Ancients do not research themselves (like alien biology)
- knowledge in tangible form

The last item is dependent on the particular Ancient. Ancients do use knowledge as a currency among themselves, and one form of tangible knowledge is in the creative output of a culture. An Ancient might be a collector of certain types of music, another might find one of particular race's foods a delicacy, and so on. And these might not be the tangible items you might expect. One groups of Ancients might pay a good price for new compositions in the equivalent of bubblegum pop, and another might wax poetic over the quality of fresh turnips from one particular valley.

**!** If you consider the Ancients to be decadent, meddling, nosy, touchy busybodies who have both the technology and the blackmail material to avoid being called to account for anything they do, you would not be too far off. But, that is just the human perception of them. From their own standpoint they are altruistic and noble and simply seek to avoid taking a loss on their efforts to help the younger, lesser inhabitants of Aethos' surface.

**!** Keep in mind that another way of gaining quanta is for an Ancient to turn their own in-race money into quanta usable by outsiders. The exchange rate for this is based on a constantly fluctuating internal system based on how much information is available for sale and being sought. That is, the gamemaster can use it as desired to get to a particular outcome.

**Calendar:** Like currency, there is no standard between races. Most use Aethos' twenty-seven hour day, and have a 'year' based on whatever that amount was for their homeworld. Humans have a day based on twenty-seven hours, divided into nine hour segments, a seven day week, and thirteen months of four weeks each in each arbitrary 'year' (364 days). The months are linguistic variants of the Western calendar, with the extra month being named Sol in memory of Old Earth's sun, and placed between the months of Juno and Julio. Most of the time *players* will just use the current terms they are familiar with, but you can make up specifics if you want to keep a more in-game flavor to adventurer conversations.

Within the human calendar, there are four national holidays of note, and individual states usually have a few that relate to that region's history on Old Earth. So there might be a local Alamo Day, Bastille Day or Guy Fawkes' Day (even though there is no England or France anymore), and it is up to the gamemaster to add these in as needed for adventure flavor. Need a chaotic parade with fireworks as a backdrop for an adventure? *Then it must be Chinese New Year!* Individual Customs *may* have one holiday per year, which employers must recognize for employees in that Custom. For instance, Pastafarians may come to work dressed as pirates on their high holy day, if they choose to come to work at all.

On the national scale, the important holidays are vacation days for the government and most businesses except the retail and food sectors.

**Founder's Day:** It is always on Sol 1, and has the atmosphere of an Irish wake. There is sorrow at what has been lost, but memories of what remains. It is sort of a cross between the American Independence Day and a funeral. Cookouts, speeches, laying of wreaths, and so on.



**Festival:** A holiday that falls on December 20, and is used by various subgroups to represent a variety of Old Earth holidays that occurred around this time. Biblists call it Christmas, Neogians call it Winter Solstice (even if Earth no longer has winters), and so on. It is a time of gift giving and charity and forgiveness, and being near the end of the fiscal year, a chance to move inventory off the shelves and make the year's sales look a little better. It is also a high-alert day for the military, ever since the third Earth-Cartoo War started with a Festival-day assault by the Cartoo.

**Veterans Day:** March 4, and is in remembrance of all who have died defending Earth, whether in military service or not, and those left far behind who defended the Old Earth against the Aeth. There is usually a lot of political posturing on Veterans Day if it falls in an election year. Stores and government offices are closed and Earth as a whole is generally not open for business until the following Monday.

**Thanksgiving:** October 19. It is a holiday that shares only a name with the Old Earth American holiday. The early days after the Exodus were filled with hardship, and Thanksgiving remembers the first harvest from the alltrees that sprouted from Terran soil shortly after the Exodus. It is a day of total fasting from sunrise to moonset (18 hours), followed by a starnight of feasts on traditional alltree recipes, which vary from state to state, but which usually include some version of all-tree vodka, humanity's first genuinely new alcoholic beverage in several centuries.

## Geography

Earth is a hexagon-shaped chunk of territory on the east side of a polygon it shares with three other races, the Cartoo, the Drinn and Tuaqq (all of which have non-hexagon shaped nations). The Cartoo and Tuaqq suffered a bit of damage when chunks of Old Earth were laid on mostly barren scarth next to each. And by 'a bit', we mean rivers of molten lava kilometers wide where thousands of kilometers of terrain were friction-fit against each other, along with uncounted F5 tornadoes and weeks of wildfires and hurricane-force winds that killed several million sentients throughout the polygon.

This sort of terrain melting *also* occurred on Earth's *internal* borders, where the score or so of terrain chunks were laid together like sod, but normal weathering has hidden most of the signs, and flora and fauna migrating across these borders have all but hidden the signs of humanity's violent transplantation.

! It is worth noting that historically, the Aeth do not pay any attention to colonies outside of a race's home terrain. That is, if they want to lay something else there, they do not pay any attention to the fact that someone was *already living there*. This puts all external colonies that are in empty polygon spots at risk. This is just another annoyance or possible plot point for later in a campaign.

The map shows the state names, largest population center and significant landforms. Terran States are named for the biggest city in that region. So, while the city of Philadelphia was in the Old Earth state of Pennsylvania, on Aethos it is the state of Philadelphia, or more commonly known as just 'Philly'. That is, state names and their capital names are the same. In common usage, just the name refers to the capital city, while secondary mention refers to the state. So, 'Philadelphia' is the capital, while 'Redding(Philadelphia)' is the city of Redding in the state of Philadelphia.



Some things to remember about the following descriptions and the map:

- The fairly narrow range of latitude for Earth means the entire Earth is in a permanent temperate zone. Tropical plants survive, but do not flourish, and temperate plants now survive without their usual winter season. The only cold areas are snowcapped mountains. Plants and animals have spread far from their original state of origin.
- Minor towns and cities are not listed by name for clarity, the larger of them are just marked. Communication and transit lines usually go to the next closest population center and usually follow the easiest path to get there (a minimum of sharp elevation changes). Small towns are probably on or near these routes. Where state borders are jumbled, there may only be one or two good border crossings. Borders are given a subjective note to give a feel for how many roads or rails cross it.
- All state borders were originally lava fields for kilometers on each side, but in many cases are now indistinguishable from the adjoining terrain.
- Archival originals of a particular Old Earth language and scholars in that language are almost certain to reside in a state with that as the native language on Old Earth. For instance, any remaining Old Earth documents in Norwegian are going to be in Bergen.
- The Aeth seemed to care but did not let themselves be bound by the original north-south orientation of the places they took. They were placed adjacent to each other by some Aeth logic, and parts of Earth no longer have the same facing as they did on Old Earth.
- The map shows relative elevation, *not* land cover. Areas of the same color are approximately the same elevation. Large color changes at a state border mean that there is a real mess at this point. Erosion and landslides will have diffused this difference over the centuries, but it will still be rugged and unstable terrain, prone to avalanches, sparsely inhabited and with limited access routes across that border.

## Denver (Colorado, United States)

**location:** southeast face

**terrain:** mountainous

**climate:** cool temperate

**borders:**

Santiago(NE, rugged)

Canberra(N, rugged)

Tokushima(NW, rugged)

Mieres(SW, rugged)

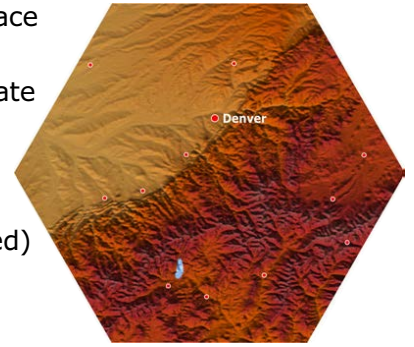

This state has the third-highest average elevation on Earth, with nearby Kathmandu being the highest. The mountains of the nearby Front Range are over 4,000 meters above standard central sea level and remain snow-capped throughout the year, with numerous glaciers whose melt becomes swift rivers that flow into the Sea of Japan. Like Kathmandu, the road and rail network is well-developed but limited in scope by the rugged terrain in many parts of the state. Outside of the corridors to the many mining cities, roads are unimproved and suitable for off-road manually driven vehicles only. Much of Earth's precious metals, iron and lead are mined here.

A unique feature of the state is Gray's Gyre. The highest peak of the state is placed so that it catches a nearly permanent high-altitude air current, causing an eddy downwind of the mountain that generates a continuous blizzard and whiteout several kilometers across. The underlying terrain has been buried under hundreds of meters of snow, compacted into an Aethos-created glacier that flows from the area, melts and becomes Gray's River. The area is uninhabitable, and numerous explorers and daredevils have failed (often fatally) in attempts to cross the Gyre without the assistance of special vehicles. The area near the Gyre is mostly uninhabited due to occasional perturbations of the Gyre and the massive avalanches that regularly spill from the snow dome at the center of the Gyre.



## Tampere (Finland)

**location:** north central

**terrain:** lakes, forest

**climate:** temperate

**borders:**

- Petrograd(N, open)
- Bergen(NE, moderate)
- Phoenix(SE, open)
- Roanoke(S, moderate)
- Montreal(SW, moderate)
- Philadelphia(NW, open)

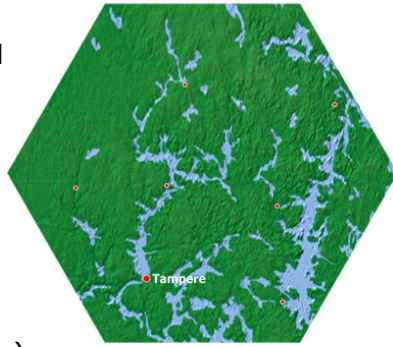

The state is composed of low-lying land with numerous lakes and evergreen forests. Many of the long, branching lakes are used as transport corridors for timber, and over the centuries a network of canals has connected most of them and most of the other towns and cities in the region are on lake shores, and private boat ownership is common. The road network is still well developed, but is often slower than water travel because of numerous detours around lakes (since too many bridges would interfere with water traffic). Used like highways, the lakes have separate corridors for traffic, heavy commerce, and designated fishing or recreational zones, and these are policed much as roads would be anywhere else.

Something that is a little-known (and perhaps suppressed) part of the historical record is that the state of Tampere is *exactly* centered on the ancient Old Earth meteor impact structure of Keurusselkä. Nearly two billion years old, no visible surface traces remain, but it seems far from coincidence that the state is so precisely centered on it. Investigations by the TSO have uncovered nothing other than an apparently natural weak circular magnetic anomaly in the rocks of the surrounding area.

**!** Magnetic compasses are useless on Aethos (they oscillate unpredictably), but since the suns are always south of you (in the northern hemisphere), if you draw an imaginary line through the suns from horizon to horizon, the midpoint of that line is due south.

## Kathmandu (Nepal)

**location:** east face

**terrain:** mountainous

**climate:** cool  
temperate

**borders:**

- Phoenix(NW, open)
- Canberra(SW, rugged)
- Santiago(S, rugged)
- Mexico City(N, rugged)

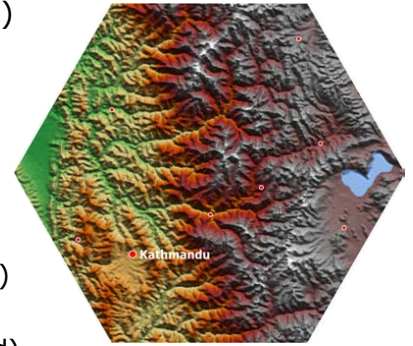

This is the state with the highest average elevation, highest state capital and highest mountain on Earth, Mount Xixa at 8,200 meters. However, the thicker atmosphere of Aethos means that this and other high peaks on Earth can be climbed or stayed on for extended periods without supplemental oxygen. Kathmandu is also the thickest 'slice' of Earth taken by the Aeth. While other parts of Earth were of varying thickness, perhaps to better join with one another on Aethos, Kathmandu's thickness is virtually the same as it would be compared to Old Earth standard sea level. This makes it less accessible from many directions, though the capital has easy access from neighboring Phoenix.

The climate of Kathmandu is generally cold because of the elevation, but rainfall patterns have improved the quality in some regions. The Himalayas tend to catch most of the remaining moisture in the winds coming in from the west and drop it as snow or rain on the west slopes, leaving the eastern half of the state a cold desert. However, the windbreak of this hexagon extends some kilometers higher and catches high-altitude moisture, some of which falls as rain. In particular, the plains surrounding Paiku Lake are now lush grasslands, and support vast cattle ranches that feed several states. A rail line dedicated to just the cattle industry has been driven through the mountains, though it goes no further, since Kathmandu is up against this polygon's windbreak. Paiku Lake is also home to Earth's tallest waterfall. Outflow from the lake spills into the scrublands to the northeast, a drop of several thousand meters.



The scrublands to the northeast and southeast of Kathmandu are all but uninhabited. The several kilometer drop on the west approach and avalanches off the windbreak make this area a no-man's land. The gigatons of ice that have been known to sluice down have generated tsunami in the windbreak seas over two hundred meters high. There is some concern that the stress from Aethos activating its main drive will cause the northeast shore of Paiku Lake to collapse into the adjacent scrubland. This would drain much of the lake and cause some temporary economic hardship for lake-based businesses, but the local cattle industry would be mostly unaffected. Geosurvey instruments are placed at key locations on the shore to provide some advanced warning. People living there have not been forced to evacuate, but it has been *highly* recommended.

Because of its rugged nature and the people who lived there on Old Earth, there are Aborigine Customs here whose force of law encompasses regions rather than people. Several nomadic herder groups still live in this state, and their traditional territories (a small, remote part of the state) are Aborigine-only. Visitors must have a permit from the state and must surrender all post-Basic Era devices and sign waivers before visiting there. This is not to say that the locals eschew *all* high-tech, they just tend not to use it. Their medical care is limited, but up to modern standards, and the few times intruders with hostile intent have threatened them, the intruders found that if you are carting a large *ger* (yurt) around, you have room for a few shoulder-launched surface-to-air missiles and 15mm anti-vehicle rifles. The nomads make a pretty good living on the side catering to wealthy tourists who want to rough it for a few weeks.

! Even isolated groups like these had to mingle with and mutually support nearby populations in the first decades after the Exodus. Those who isolated themselves in the wilderness did not survive, despite their considerable skills.

## Roanoke (southwest Virginia, United States)

**location:** southeast face

**terrain:** low mountains

**climate:** temperate

**borders:**

Phoenix(NE, open)

Canberra(SE, open)

Tokushima(S, open)

Ankara(SW, rugged)

Montreal(NW, rugged)

Tampere(N, moderate)

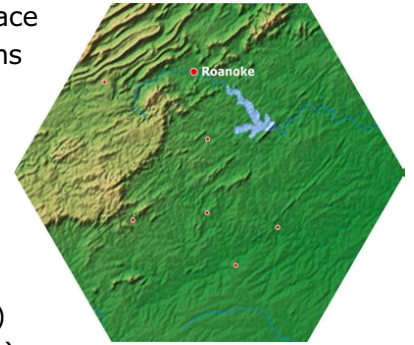

The state calls itself the 'center of everything' due its placement on Earth, but others tend to call it the 'middle of nowhere'. Mostly timberland with some farmland and a small number of low-yield iron mines and local smelters, profitable as family concerns with low overhead rather than massive corporate investments. Some manufacturers of large and heavy industrial goods (like bulldozers) have plants here, as it minimizes costs to ship finished products anywhere else on Earth.

The city of Roanoke is known mainly as a transportation hub thanks to a significant number of rail lines and its central placement. Multiple rail lines exit each border of the state, with the exception of Tokushima, which is served solely by the Gamouda Bridge, a twenty kilometer long span extending off the tip of Cape Gamouda to the Roanoke coast.

A number of corporations have their central warehouse/distribution facilities in Roanoke and their main corporate offices in more fashionable states. As a state capital, it has sprawled outside its original valley and calls itself the 'city of hills' due to its spread onto the surrounding low mountains.

The city of Winston-Salem would have been the largest population center in this state, but it was cut in half by the Aeth and the part that was transported was buried in lava (casualties unknown, estimated at more than a million). Stumps of 900-year old buildings are still visible, covered by vegetation. No systematic exploration of the region has been done.



## Juarez (west Texas, United States)

**location:** southwest face

**terrain:** hills, plains

**climate:** temperate

**borders:**

Ankara(N, open)

Tokushima(NE, rugged)

Mieres(SE, moderate)

Johannesburg(NW, open)

Cartoo(S/SW, open)

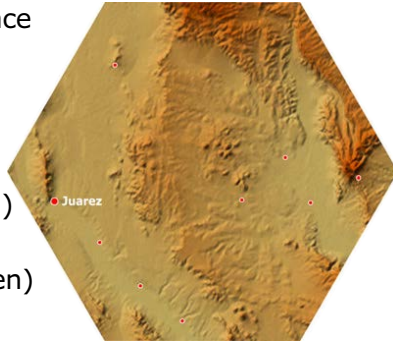

The dual city of El Paso, Texas and Juarez, Mexico was a heavily militarized zone in the late 22nd century. In the century leading up to the Exodus, the good relations that had existed between the United States and Mexico began to break down, in part due to the chaos in the wake of Mexico City's devastation by earthquake and volcano in the decades prior to the Aeth arrival. In the panic and chaos immediately preceding the Aeth arrival, the two forces were on the verge of all out war. *The Aeth blotting out the sun and scooping up the area put and end to that.* So, when the Aeth took this region, they also took two fully mobilized military forces and dropped them down on the Cartoo border. Much of their gear was destroyed or degraded by EMP effects and lesser catastrophes like having buildings fall on them or being buried in lava, but when the smoke cleared and the Cartoo started paradropping in and wheeling over the freshly cooled lava, the remnants of the Mexican and American forces were there to greet them. The Mexican Army took the brunt of the initial Cartoo attack since it crossed their territory first, and when it was all over, their horrific losses and sacrifice moved local opinion enough that when it came time to name the state, the Mexican side of the joint city prevailed.

Juarez is still a heavily militarized state due to the proximity of its main population center to the Cartoo border. Formerly arid, Aethos' climate turned the region into farmland, with dozens of small agriculture-based towns having a heavy population of military veterans. The state is dotted with sinkhole lakes from the collapse of limestone caverns, the largest of which is the remnants of the massive Carlsbad Caverns on the other side of the state from Juarez. Some of the lakes are connected to others via underground rivers. A few of the caverns remained intact after the Exodus. Some are open for exploration, while others are used as deep command and storage bunkers for military gear.

The capital city is both a military strongpoint *and* a commerce hub for most of the inland trade with the Cartoo. A bustling trading outpost exists on a large patch of otherwise useless lava on the border with the Cartoo. Both sides dispute the other's border claims on the diplomatic front, but a dividing line down the middle of the outpost is a convenient fiction that allows for negotiations and exchanges of goods in relative safety. There are several buildings where this convenient line runs down the middle of a conference table.

The city of Juarez is not so casual, however. The entire city is designed to be a meat grinder for anyone trying to invade it, and a forward base of operations against anyone who thinks they can just bypass it. The Cartoo have excellent visual detail of the city, they just lack an easy means to deal with what they see. In previous wars, Juarez has had to deal with bio- and chemical warfare, sustained artillery barrages, cyber-infrastructure attacks and suborbital kinetic bombardment. Wrecked or nearly so multiple times, but never conquered. Juarez residents are several times more likely than the average Terran to carry a legal weapon. Combined with the large military and ex-military population, minor scuffles are common (a deliberate fight seldom escalates past fists), but things like muggings and burglary are rare.





## Tokushima (Japan)

**location:** south central

**terrain:** hilly, ocean

**climate:** temperate

**borders:**

Roanoke(N, open)

Canberra(NW, open)

Denver(SW, rugged)

Mieres(S, moderate)

Juarez(SW, moderate)

Ankara(NW, moderate)



Tokushima is a portion of Japan that was surrounded by ocean on Old Earth and transplanted in an entirely inland area. Over the centuries the 'Sea of Japan' has become a freshwater sea, and many of the formerly salt-water species have adapted to the situation.

Tokushima has limited access to other states. The three states to the north can only be reached by a single bridge each, the roads and rails to Denver and Mieres have to go through rugged hills and Juarez is only accessible to the small part of Tokushima that abuts it (and then a few bridges to the main part of the state) and that border is rugged in patches. All of these routes are nonetheless in heavy use, since the Sea of Japan is Earth's main fishery and the only environment where a number of Terran species still exist.

The narrow gaps between the Sea of Japan and the states of Ankara and Canberra mean that tidal effects of the suns are much more pronounced here, generating dangerously powerful currents and whirlpools three times a day at each location. This made construction of the bridges here a difficult and expensive engineering problem, and all these bridges are toll bridges to cover the cost of maintenance.

Shodoshima Island (west side of the state) has the distinction of being the largest island on Earth. Its major city, Uchinomi, has an economy based on the local fishing industry, but is also home to Shodoshima Naval Air Station, the Terran military's port of call for the Sea of Japan. A few frigates are usually seen here, but the main force is a fleet of long-duration submarines loaded with hundreds of medium-range ballistic and cruise missiles. Historically speaking, one can guess some mix of explosive, chemical, kinetic and recon payloads, but as with most things involving the Terran military, details are classified. It is presumed these submarines run silent in the deep waters of the northeast, where they can shift location and be protected from any form of long-range bombardment.

Kamijima Island (southern Sea of Japan) is now the Kamijima Detention Complex, Earth's main high-security prison (and military research station). People who are such a danger to society that normal methods of control are ineffective will be incarcerated here, along with those who simply refuse to accept lesser forms of control or behavior modification for their crimes. Part of being sentenced to serve here is the notion that the cost of your imprisonment will be paid for by any form of experimentation the military wants to try on you, save that it has to be reversible with no (or few) permanent side effects. There is a two kilometer 'no-go' zone for both boats and aircraft and a one kilometer 'shoot or sink' zone. Both of these are enforced without exception, and the last escape from Kamijima was over two centuries ago.

! As you read the state descriptions, keep in mind that all of them are designed with at least one feature to create, support, enhance or generate a complication for an adventure.



## Petrograd(Russia)

**location:** north

**terrain:** low plains

**climate:** warm  
temperate

**borders:**

Bergen(SE, rugged)

Tampere(S, open)

Philadelphia(SW, open)

Tuaqq(NW, rugged)

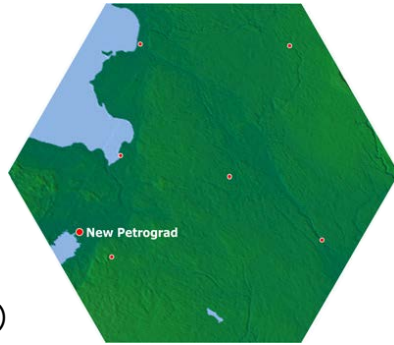

Petrograd is the most modern state capital on Earth. When the Aeth took this region, they also took a chunk of the Gulf of Finland, and during the several hour transport to Aethos, the gulf 'sloshed'. *The entire city was washed into the ocean. Several times.* Fortunately, the residents were warned of tsunami-like effects from Aeth attacks elsewhere and most of them had fled inland. Nonetheless, they had to rebuild from virtually nothing. *And they did so.* The core of the first 'New Petrograd' is now a historic district that represents the first few decades of rebuilding, but the rest of the city is a bustling modern metropolis of several million, with the best infrastructure of any Terran city. More than any other Terran city, it follows an arcology model, several huge multipurpose skyscrapers surrounded by small parks and lesser structures, with subsidiary businesses and smaller arcologies in suburbs, all linked by a largely automated mass-transit system and smart roads.

Power distribution, network access, public transport, parks and recreation are all first-rate. Of course, this comes with a high desirability that makes prices for everything in New Petrograd about +1 more than normal.

The rugged land border with the Tuaqq makes land trade with the capital a problem. Any goods coming in from that direction usually do so via the central sea to a port in the north of the state, and are shipped by rail from there to the capital. New Petrograd is one terminus of the high speed rail line that runs in a broad arc through Philadelphia, Montreal and Ankara (with a Philadelphia to Jinan branch), making rail more cost-effective and almost as fast as commuter flights, once normal terminal delays are taken into account.

Less obvious than its other amenities, New Petrograd also has very good security, from both policing and military defense standpoints, even though it has never seen heavy fighting like Juarez or Johannesburg. All of the tallest buildings and utility structures like water towers have a reinforced section subsidized by the city and considered State property. Records from past Earth-Cartoo wars show that targeting radars and surface-to-air weapons have deployed from high points, and artillery and tanks from ground-level structures. Given the distance from the Cartoo and the relatively small raids done by them in the past, some might consider the level of defense here excessive, but no alternate reason for it (outside of outlandish conspiracy theories) has been discovered.

! Censored or otherwise disappeared are records of how the public camera system and facial recognition systems were used to round up dissidents or how autocabs were overridden and driven into canals or bridge abutments when inconvenient people needed to have an 'accident' during the Civil War of 576AE. *Which of course you have never heard of, since it never actually happened. Perhaps you were thinking of the classic **Conspiracy** espionage/thriller movie trilogy from that era (see the TerraNet nmdb entry for details).*



## Philadelphia (Pennsylvania, United States)

**location:** northwest face

**terrain:** low plains, hills

**climate:** warm  
temperate

**borders:**

Petrograd(NE, open)

Tampere(SE, open)

Montreal(S, open)

Jinan(SW, open)

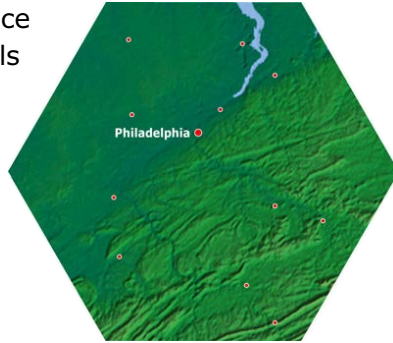

Philadelphia is the Terran capital or the capital of Earth, depending on whether you are looking at it from an alien or human viewpoint. As the original capital of the United States on Old Earth, those proud of an American descent view the city with pride. All of the historic buildings of Old Philadelphia are a museum district for cultural heritage items from Old Earth, though items regularly go on rotation to the museums in other state capitals.

**!** Every historical building in Philadelphia was turned into a pile of rubble during the Exodus, and very little of the American heritage stored there survived. The buildings were recreated from photographs some centuries later, and include exhibits like 'fragment of the 'Liberty Bell' (reconstructed appearance in exhibit to your left)'

Philadelphia is the seat of Terran government and includes the Executive Estate, Legislaat and the Supreme Adjudicaat, all of which are in a multi-hectare secure zone that appears relatively open, but which in fact is the most information-dense and sensor-probed piece of real-estate on Earth. Threat of assassination or attack on high-ranking officials is very real, and everything about the government district is designed to reduce this threat without making the area look like a maximum-security prison. For instance, every legal weapon has its position known to the centimeter, and massive banks of computers monitor this in real time, sufficiently well to know if a weapon is in its holster or drawn if it is in an area with corresponding camera coverage.

Backscatter radar on virtually every street corner checks for the presence of firearms under clothing. If there is no corresponding RFID tag, the wearer is *immediately* arrested. Any building with a direct view of key locations has high quality door and window sensors, as well as remote cameras. If a janitor takes a lunch break on the roof, Capitol Security knows about it before the door has finished closing. All communications are monitored for keywords, all identities are verified and matched with databases to look for unusual travel patterns, and so on. All by itself, this level of security uses a measureable fraction of Earth's computing power, while back on Old Earth it would have been one sub-basement's worth of CPUs.

The average person may know of all this, but they are largely unaffected and residents pay it no mind. However, to maintain an illusion of vulnerability (to help catch the more inept plotters), conventional criminal activity picked up by this surveillance is generally not passed on to the StatePol, leading to a bit of official tension between Capitol Security and regular law enforcement.

Legislators and the like know about the security and have their own 'exclusion zones' where this eavesdropping does not apply, allowing for confidentiality in legislative deals and backroom vote wrangling. Whether or not the TSA *actually* refrains from surveillance in these areas is another matter, but thus far no evidence has surfaced to the contrary.

As the capital city of Earth, Philadelphia is a desirable (and expensive) place to live and do business, with +1 to all costs. This leads to a widely scattered service economy, with lower and middle-class workers often commuting long distances from more affordable locations. Philadelphia's subway system extends at least fifty kilometers in every direction, and the city has dedicated outlying communities just to handle specific needs of the city (power, waste, water, mass transit, etc.).



## Jinan(Shandong, China)

**location:** northwest

**terrain:** plains, hills

**climate:** warm  
temperate

**borders:**

Philadelphia(NE, open)

Monstreal(SE, open)

Vlaidvostok(S, moderate)

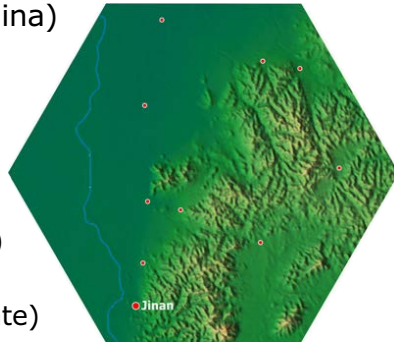

Jinan is an aberration from Old Earth, a genuine megacity. With a population of over ten million at the time of the Exodus, it is by far the largest of the Old Earth cities to be transplanted to Aethos. Mexico City was *physically* larger, but was in far worse shape and much less inhabited at the time. A side effect of this population was the *staggering* number of casualties from the Exodus, with some estimates of over ten million dead. This led to two very important events. First, when the Cartoo sent several 'salvage divisions' into the province and the capital to loot gold, rare-earth concentrations (electric vehicle motors, etc.) and anything else portable and valuable, the survivors thought the Cartoo were the Aeth. Such was the hatred and outrage and grief, the poorly armed survivors fell upon the Cartoo as a human wave, dying by the hundreds of thousands to get their vengeance on the 'Aeth' who did this to them. The losses to the Cartoo were greater here than any other place on Earth, but such was the ferocity and savagry of the fighting that Jinan was not attacked at all in the *second* Earth-Cartoo War.

! As an example of Cartoo humor, the clan that got beaten in the first Jinan assault is *still* taunted with "Watch out! He *doesn't* have a gun!"

The other item of note is that the first alltrees in the state tended to spring up in the areas with the highest concentration of mass graves. Even nine centuries later, natives of the state tend to call them 'ancestor trees' or 'trees of the dead'. Thanksgiving is a much more somber holiday than in other states.

The survivors knew that the fruit that kept them alive, the wood that built their shelters, the oil that lit their lamps, all came from trees nourished by the flesh and blood of their family and friends and countrymen.

Because of its open terrain and proximity to the Cartoo, Jinan became a target again during the third Earth-Cartoo War, who tried to take and hold it long enough to force territorial concessions 'to compensate for the damage caused by Earth to the Cartoo people' (among other excuses). The long sight lines and good visibility made this front hell for infantry and not much better for anything else. Long range tank duels, over the horizon artillery barrages and multijet dogfights were the norm, infantry being tasked to simply occupy the territory and try to survive. The cumulative casualties and the number of veterans who chose to stay here resulted in a forced mixing of genes and culture over the past nine centuries. This piece of China found that it was absorbed by everyone else, rather than the other way around.

The geography of Jinan is urban sprawl in the south, farms and agricultural businesses on the coastal plains, with heavy industry in the low hills of the east. Many of Earth's vehicles are manufactured in Jinan factories. While it is not a major industry, a few concerns are manufacturing spare parts for alien vehicles or otherwise trying to break into non-human markets.

A number of monuments from Old China remain or have been rebuilt, including ancient temples and a piece of the Great Wall of China, including annotations for when it was used as a line of defense in the first and third Earth-Cartoo Wars.

! Because of the difficulty of learning it and the limited number of scholars teaching it, a written fluency of the Chinese language requires an Unusual Background to explain the circumstances of how you acquired it. Otherwise, any knowledge of the language is spoken fluency only.



## Montréal (Québec, Canada)

**location:** northwest center

**terrain:** river plains, hills

**climate:** warm  
temperate

**borders:**

Ankara(S, rugged)

Jinan(NW, open)

Philadelphiam(N, moderate)

Tampere(NE, moderate)

Roanoke(SE, rugged)

Vladivostok(moderate,SW)

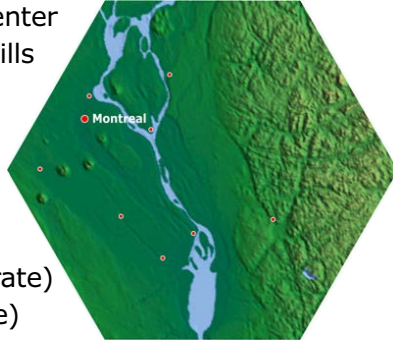

Montréal is by default, the last bastion of the French language. It is not commonly spoken anymore, of course, but as a French-speaking province of Old Canada, it has the most of Old Earth's documents in this dead language.

Originally situated on an island in the St. Lawrence river, the center of Old Montréal was turned into a graveyard of shattered skyscrapers, more a mound of masonry than the ruins of a city. After the industrial metals were mined from the debris, what was left was turned into wooded parkland and nature preserve. The current city of Montréal is the 'Old City', the areas that were merely ruined rather than rubble, and the new city, which surrounds the central island. The St. Lawrence now flows in the opposite direction it used to, fed from the Ankara highlands in the south. It is navigable for its entire length in the state, and is used for some bulk shipping.

For reasons lost to history, Montréal is the entertainment capital of Earth. The major studios are all based on Montréal and there are dozens of musical styles that have called Montréal home over the centuries. Rooms full of computing power are needed to speedily do effects an early 21st century studio could do with a handful of GPUs, so actual location shooting and physical special effects are just as important for a scene as a post-shooting VFX crew is. Studios have been known to shoot action films in actual alien ruins, just for the realism angle.

## Vladivostok(Russia)

**location:** west face

**terrain:** hills

**climate:** warm  
temperate

**borders:**

Jinan(N, moderate)

Montréal(NE, moderate)

Ankara(SE, rugged)

Johannesburg(S, moderate)

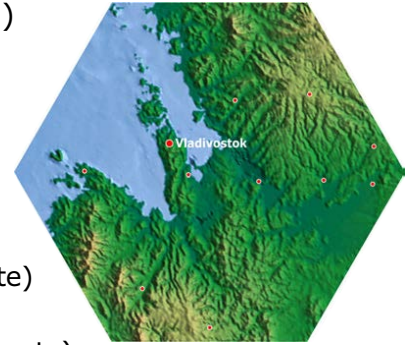

Vladivostok had a 'natural' defense in the first Earth-Cartoo War in the form of massively armored underground submarine bases. All the nuclear submarines and their warheads were deployed to the deep ocean at the time Vladivostok got scooped up and were not there to help against the Cartoo. However, it was a strongpoint impenetrable by conventional weaponry, it survived the Exodus physically intact (if jumbled a bit) and had underground warehouses full of nearly forgotten military hardware, like conventional, unaugmented assault rifles from the mid 21st century, along with millions of rounds of ammunition in nitrogen-sealed cans. These antique AZ-45s were not exceptionally effective against armored Cartoo, but they made mincemeat of sensors and lightly armored low-status Cartoo troops. More telling was a small stockpile of OSV-32 anti-materiel rifles using the obsolete 14.5mm heavy MG round. The Cartoo had never developed nor had any experience with a handheld weapon so massive it reduced its owner to a walk (they never had a land war with the Drinn to get that experience). This simply did not fit in with their 'strike fast' doctrine. So, Russian snipers picking off light vehicles and heavily armored troops (especially leaders) from a distance of two kilometers was quite a shock. These snipers became priority targets for the Cartoo. None of them survived the first Earth-Cartoo War and only one OSV-32 is known of, in the 'People's War' Museum in downtown Vladivostok. Locals call the first Earth-Cartoo War the 'People's War' for an obscure reason associated with its Old Earth political structure.



The AZ-45 is considered a 'cultural heritage' weapon on Earth. This gives it no special legal treatment, it is just a mark of honor. Enough replicas have been manufactured that ammo and accessories are its own industry. Few originals in good condition remain, mostly as family heirlooms and museum pieces. Ones that come up for auction sell for a hundred thousand Eur for one in good cosmetic condition, more if it has a provable provenance for certain key battles in the first or second Earth-Cartoo Wars.

The underground parts of the Vladivostok naval base were collapsed by suborbital kinetic bombardment during the third Earth-Cartoo War. They were replaced with a distributed network of lesser shelters, designed to protect one vessel from guided missiles, and give it time to reach open ocean. Command functions are in one of several smaller, deeper bunker in the hills south of the city.

Like before the Exodus, Vladivostok's economy is based around ocean shipping, commercial fishing and the naval base. Earth's navy is rudimentary, and exists mainly to counter the Cartoo navy. Commercial shipping more than makes up for this, Vladivostok having an excellent deep-water harbor. It ships bulk goods to and from the Tuuqq and especially the Drinn (which Earth has no land border with). Terran species predominate in the waters close to Vladivostok, while they have to compete with others in the open ocean. Terran fishermen go after whatever there is a market for, whether for Terran or alien consumption.

Vladivostok also has a small coal-mining industry. Not commonly used for fuel or heating anymore, a few mostly local primitive Customs still burn it, and it is also mined to extract its relatively high germanium content. The region also has numerous clays suitable for brick-making, and many structures in the 'traditional' style use these, as well as recreations or restoration of Old Earth historical structures.

## Ankara(Turkey)

**location:** southwest  
**terrain:** hills, shallow sea

**climate:** temperate

**borders:**

Montréal(N, rugged)  
Roanoke(NE, rugged)  
Tokushima(SE, moderate)  
Juarez(S,open)  
Johannesburg(SW, moderate)  
Vladivostok(NW, rugged)

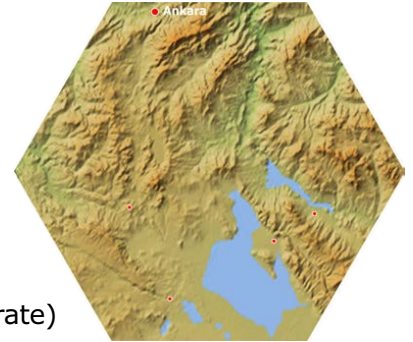

Old Ankara was badly damaged during the Exodus. Building codes, even when adhered to, were not a match for the earthquakes caused by transport of the region. Worse, the city was almost on the edge of the hexagon and parts of it were buried in lava. Only its complete lack of utility kept it from being a target during the first Earth-Cartoo War. Rebuilding was slow. It was not until decades after the first Earth-Cartoo War that a rail line connected Ankara to the rest of Earth. Despite its proximity to the border, the only land route to Montréal is a winding manual road down the Ankara Escarpment and a rail spur that detours to a corner of the state and then zigs back over more stable terrain. Most other traffic runs through improved mountain roadways or rails, west to Vladivostok or south to the Sea of Japan. A bridge now links Ankara to Tokushima, but Ankara as a whole is less accessible than you might think for someplace only two states away from Philadelphia.

New Ankara is a modern city with some unsettling disparities. Set far enough back from the Montréal border to be safe, the view from Ankara skyscrapers looks down the border escarpment to the Montréal lowlands some thousands of meters below. Runoff from the mountains pours down the cliffs and slopes in hundreds of spectacular waterfalls and rapids. But Ankara also has a statistically high level of income disparity and non-integration with normal Terran life.



There are still a few tribal groups living in the hills whose conduct is a Custom in name only, and is closer to a mandatory lifestyle for anyone raised there. The closest it comes to for most Terrans would be to call them Orthodox Conservative Seekers. Like all other groups, they had to mingle and adapt in order to survive the decades after the Exodus, but after doing so and adopting the minimum of outside ways, they became insular again. These groups are small in number and isolated, so as long as they do not cause trouble and do not overtly coerce anyone to prevent them from leaving, the local StatePol tend to overlook their minor infractions of Custom.

For reasons known only to the Aeth, there is a minor access portal at the boundary between Montréal, Vladivostok and Ankara. This was apparently in place at the time of the Exodus and Earth's states were placed to fit it. Only a few kilometers across at the top and only extending a few kilometers above the local terrain, it is nonetheless an anomaly on the usual Aeth pattern. It is irregularly used as a heat vent and even more infrequently as a ship portal. The Terran government has a small but permanent research station devoted to monitoring the portal, with most of the staff based in offices on the outskirts of the capital.

Climbers and daredevils regularly scale the portal and this does not seem to be of any concern to the Aeth. Accidents involving these antics cause several fatalities per year, quite often because the no-fly zone around the portal precludes medevac flights that would otherwise be used for rescue efforts.

Settlement within ten kilometers of the portal is prohibited, but people do it anyway. With a new Arrival starting, local portal squatters are getting nervous and many are moving back to Ankara. Others who used the portal as a way to leave local Custom without leaving the area are considering returning to their prior communities.

## Johannesburg(South Africa)

**location:** southwest corner

**terrain:** hills

**climate:** warm  
temperate

**borders:**

Vladivostok(N, rugged)

Ankara(NE, moderate)

Juarez(SE, open)

Cartoo(S/SW, rugged)

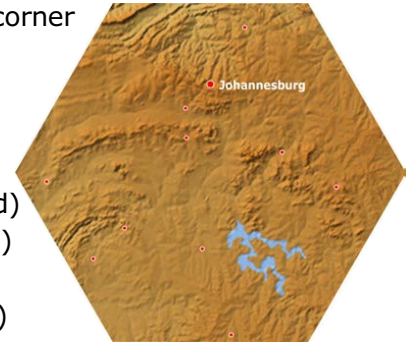

Like Juarez, Johannesburg was an opening objective in the first Earth-Cartoo War. Unlike Juarez, it did not have the remnants of two major armies there to defend it, and it was quickly overrun and occupied. It was a very ugly time, with traitors helping the Cartoo loot the region, often out of a desperate need for food and shelter but sometimes out of simple opportunism, and both human resistance fighters and Cartoo occupiers engaging in atrocities. The fighting over Johannesburg lasted several years and only ended when Tuaqq-equipped troops from the 'Bliss Brigade' (Juarez), augmented by a dozen Orb-fortified super-soldiers did a pincer on Johannesburg with the help of a massive mechanized infantry assault using Jinan troops and Tuaqq APC's covertly shipped into Vladivostok. Attempts to airlift the Cartoo defenders out were shot down, and retreating Cartoo were attritioned down to nothing before they could reach their own territory.

All of this meant that Johannesburg is the city with the strongest anti-Cartoo sentiment (Jinan is second), even after nine hundred years. It is not a 'hatred with the heat of a thousand suns' thing, it is just that popular culture and the general upbringing of anyone in the state, especially the capital, has a strong anti-Cartoo bent.



The state economy is based mostly on mineral extraction. The state has Earth's highest concentration of the elements used for electric motors and exocaps, though new deposits are fairly rare and existing ones are mostly played out. Nonetheless, the state has always been a target of the Cartoo for its resources, since *their* native supply of these things is now almost exclusively through alltree cultivation, still an order of magnitude more costly than conventional mining.

Like Tampere, there is a major meteor impact structure in Johannesburg. Unlike Tampere, it is actually visible from orbit and is *not* in the exact center of the state. It is seen as too far from coincidence that two of Earth's older and larger impact sites just happened to be places that the Aeth took from Old Earth, though no satisfactory reason to explain why has ever been produced.

There is very little trade with the Cartoo across the border of this state. Instead, there are numerous farming or mining communities that are also pillbox-studded defensive positions, with underground bunkers of surplus war material, giving the local StatePol enough firepower that any Cartoo incursion cannot just bypass these communities. These communities would not be expected to hold off a dedicated assault, but they would be expected to slow it down enough for the regular army to bring its force into play. Maps of mines, caves or any subsurface structures are considered confidential information. They are not 'classified', they are just not available for public viewing.

The average age at which a person exhausts their lifetime medical benefit is lower in Johannesburg than any other state. No malfeasance or corruption has ever been proven. Of course, this information on average lifespan in Johannesburg is also classified and not available through normal channels.

## Mierres(Spain)

**location:** south corner

**terrain:** hills

**climate:** warm  
temperate

**borders:**

Juarez (NW, rugged)

Tokushima(N, moderate)

Denver(NE, rugged)

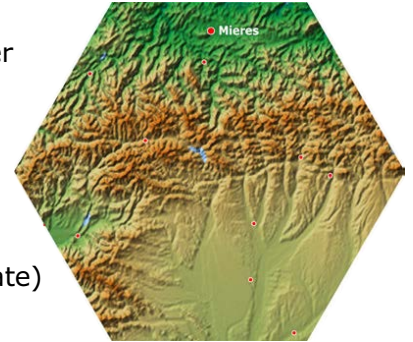

Gijón Launch Complex was part of the Spanish anti-Aeth effort on Old Earth, one of many militarized spaceports built in the century of waiting for the Aeth to finish decelerating. Once the last of the payloads and ships were launched in the final days of Old Earth, the full military garrison pulled back to Mierres del Camino in anticipation of Aeth strikes against Old Earth's launch sites, strikes which never happened. Instead, the Aeth took the entire chunk of Spain south of the spaceport, along with the military garrison and the researchers and spaceport techs they were protecting.

Mierres was a small town at the time. The evacuated personnel were in trailered-in housing, while the military was in a standard field encampment. While Mierres suffered from the earthquakes of transport like everywhere else on Earth, the temporary quarters for the military and techs were largely unaffected. Almost all their electronics were fried, like all the other transplanted terrains, but most military tech has built-in fallback positions in case of computer failure, leaving it functional, just not enhanced. This left the Spanish army in passably good condition, but with no way to get anywhere. Fortunately, the Cartoo decided to 'pacify' the only real population center in the state about the same time they were attacking Juarez. The Cartoo airdropped light armor was technologically superior to degraded Spanish forces, but the Spanish had the advantage of a semi-prepared defensive position and a pair of fledgling Orb supersoldiers.





Even so, casualties were very high on the Terran side, including both of the Orb soldiers. One of them survived long enough to explode into a cloud of Spores that infected virtually all the surviving Spanish soldiers and quite a few of the other people in the area. This turned the fighting completely around over the course of the next week, though about a third of those infected eventually died, either due to injury or Spore side effects.

During the first decades of rebuilding, the concentration of Terran tech know-how at Mieres was a great resource, if only to figure out how to make the most of 'loaned' Tuae tech.

Over the centuries, Mieres has grown into a university and high-tech industrial city. Terran versions of Tuae exocaps were developed here, and any alien technologies brought back by explorers often end up in Mieres labs for analysis and potential reverse-engineering.

Mieres is the smallest of the state capitals. Its legislative representatives lean towards Liberal Intellectual Capitalism, which generates some discontent in the minority rural population, which leans Conservative.

Aside from manufacturing and research, the hills south of Mieres are good for wine and olive cultivation. The southern plains that drain into the Scrublands are given over to massive alltree plantations, fed by the nutrient-rich runoff from sheep farms that line the foothills. The wool, meat and alltree products are the second highest source of state revenue, though not as concentrated as the industrial output in the north of the state.

## Santiago(Chile)

**location:** southeast corner

**terrain:** hills

**climate:** tropical

**borders:**

Denver(SW, rugged)

Canberra(NW, rugged)

Kathmandu(N, rugged)

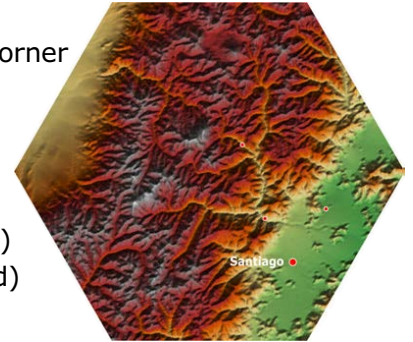

Santiago is Earth's most inaccessible, least hospitable and least integrated state, on the wrong side of the Andes mountains from everyone else and furthest from the capital in Philadelphia. In addition to being physically remote, the Andes block most of the moisture that makes it to the east edge of this polygon, leaving only a small amount to fall as rain. Its southeastern plains are good for farming using irrigation, but are vulnerable for several kilometers inland from waves generated by irregular ice avalanches from the windbreak. The combination of dry air and high mountains on both sides creates a number of extremes. The lowlands are hot and dry near the mountains, and hot and humid near the windbreak sea. The uplands are dry except for snowcapped peaks and the narrow valleys that glacial runoff cascades through. The turbulence from wind rolling over the mountains generates near-perpetual cloud-banks in some areas, but any rain from them evaporates before it reaches the ground. However, the lightning from these storms is nearly constant, does reach the ground, and in any case, no one dares to fly into these areas.

Because of its physical and political isolation and generally poor weather, Santiago does not have a lot of outside investment. The food produced there cannot compete on the open market with states having shorter shipping routes, Santiago manufactures little that Earth needs. Costs of living in Santiago are at -1, though the cost of goods remains the same. Even the Cartoo did not bother with the area during the first Earth-Cartoo War.



During the third Earth-Cartoo War they tried to take it as a foothold, but were repulsed with heavy casualties and property damage when the Santiago defenders blew up hydroelectric dams in nearby valleys and flooded the capital city with a wall of water seventy meters deep at some points. The rebuilding effort after this helped put Santiago 'on the map', as it were, with an extremely expensive rail line through the Andes, branching to both Canberra and Denver. And 'through the Andes' is a literal statement, with multiple tunnels tens of kilometers long, many of which also house military bunkers.

Even with military subsidies, Santiago is still poor, with only limited network access. Because of its isolation, it is home to many groups of outcasts, those who are not quite adventurous or wealthy or numerous enough to found an outside colony, but who are far enough outside the mainstream to be uncomfortable with normal Terran society. While officially denied, there are rumors of entire isolated communities based off forbidden Customs like exceptionalism or racism. The Terran government generally turns a blind eye to these, as the groups are small and barely able to support themselves, much less cause any widespread social harm or unrest. Occasionally, someone in one of these communities will do something outrageous enough that the authorities have to step in, but the news reports are generally filtered and sanitized down to innocuousness by the time they make it out of the state.

There is a minor Aeth portal at the southeast corner of the windbreak sea, but the capital city is far enough away to be safe. Since the sole access to it is by water, few squatters live there. With the Aeth more likely to use that portal as a heat vent, it is considered unusual that none of these squatters have fled for the mainland. Broadcasts from the low-power, portal-based 'Radio Free Santiago' continue as normal, but personal radio transmissions seem to have gone silent.

## Canberra(Australia)

**location:** southeast

**terrain:** hills

**climate:** warm  
temperate

**borders:**

Phoenix(N, moderate)

Kathmandu(NE, rugged)

Santiago(SE, rugged)

Denver(S, moderate)

Tokushima(SW, moderate)

Roanoke(NW, open)

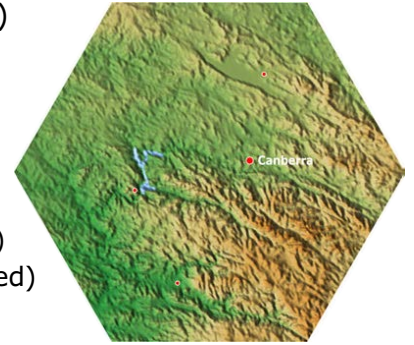

This state is home to the former capital of the Old Earth nation of Australia. Canberra has the dubious distinction of being the most poisonous state on Earth, with poisonous snakes, insects, mammals, and even one species of bird with neurotoxic flesh as a defense against being eaten. And since every state on Earth now has portions with a climate suitable for these creatures, there is a chance of finding them just about anywhere. However, the greatest likelihood is in or near this state. This does not mean there is a poisonous spider under every rock, but Canberra natives are more attuned to the potential hazards and every hospital in the state has a wide selection of anti-venom treatments.

The spread-out nature and relatively low structures of 22nd century Canberra meant it had minimal human casualties during the Exodus, and it was able to recover and rebuild fairly quickly. Major parklands were timbered for early rebuilding and turned into agricultural fields or alltree plantations, though by the end of the first century, most of this was in the process of being reversed. The city of Canberra is still much less vertically oriented than other major cities, and offsets this with a very good mass-transit system. The many parks and small forests in the middle of a sprawling city of several million gives many people who might otherwise never leave a city a sanitized taste of 'the countryside' (albeit with a few poisonous snakes and spiders).



In fact, areas of the larger parks are set aside for outdoor pursuits, and people will actually take vacations within city limits, though things like camping permits have a year-long waiting list. Even Aborigines need to have permits to wander between parks, just to keep too many of them from flooding the area. There is even a small aquatic Aboriginal subgroup, using primitive sailboats to zigzag across Lake Burley Griffin and the much larger Lake George, often making a few extra Eur by giving leisurely sightseeing tours to visitors, with either highly exaggerated or suspiciously accurate tales of the city's history, depending on who you ask.

Canberra was and still is the home of Canberra Military College and the Terran Defense Force Academy. The proximity to virtually all of Earth's terrain types and the added 'benefit' of poisonous fauna is considered a benefit when training for alien environments.

Outside of the capital, the low southern mountains are dotted with mines, including some of Earth's few rare earth mines. These are considered a strategic asset, and in terms of how much military force can be brought to bear to defend them and how fast, these mines are much better defended than they might appear. The foothills are often home to livestock or managed timber and the north-eastern valleys are mostly agriculture. There are a few heavy industries and cities based on resource refining, but Canberra is far less industrialized than someplace like Bergen or especially Jinan.

## Mexico City(Mexico)

**location:** northeast corner

**terrain:** hills

**climate:** cool  
temperate

**borders:**

Bergen(NW, rugged)

Phoenix(SW, rugged)

Kathmandu(S, rugged)

Tuaqq(N, moderate)

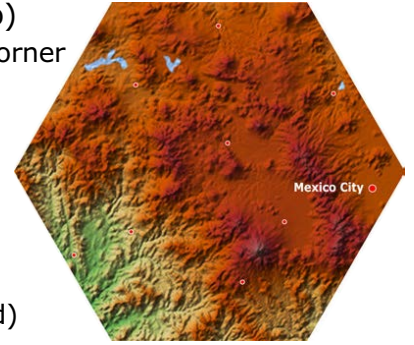

This state breaks the normal Terran naming conventions. The state is called Mexico, while the capital is Mexico City, an outright separate name rather than the inference used for most other states and capitals. Mexico is cooler and wetter than it was on Old Earth. The high plains are more akin to summers in latitudes a thousand kilometers further north than they were on Old Earth. Mexico City itself gets frequent heavy rains from the windbreak that rises out of sight to the east. Mexico City would be a lake if one side of the bowl-shaped valley it occupied had not been cut off by the Aeth when they took this chunk of terrain. Northeast and southeast of the city, the terrain crumbles down into broken scrublands, land that still steams from underlying magma chambers.

On Old Earth, Mexico City was nearly a dead city. The disastrous extended eruption of the Popocatepetl volcano in 2154CE buried the city under volcanic ash faster than it could be scooped up with earthmoving equipment and the earthquake of 2157CE collapsed hundreds of structures and killed nearly a million people at a time when the Aeth were approaching and other nations were unwilling to overextend themselves to offer relief. If it were not for the slow-motion nature of the catastrophe, the nation of Mexico might not have survived long enough to see the arrival of the Aeth.

At the time of the Exodus, Mexico City had dropped from a population of over twenty million to two million, many of them squatters or looters, the rest being a military garrison, civil engineering crews, a skeleton government and bureaucracy and a few large employers lured back with promises of subsidies and tax breaks. Mexico City did not suffer that much during the Exodus for the simple reason that just about everything capable of falling down had *already* fallen down and what little had been rebuilt was overbuilt. There was *still* a lot of structural damage to the buildings, but they remained standing.

With a military garrison and every third person being involved in the construction industry, Mexico City had a long way to go to rebuild, but it had the tools and people to do so. Of necessity it became a salvage city, tearing apart the bones of the old city for the steel to build the new. After the rebuilding, the mills and smelters were the best facilities for ore from other parts of Mexico and Bergen, though this industry faded over the centuries and most of the mills are either torn down or occupied by squatters. Mexico City is now mostly a seat of government for the state and headquarters for a few of the state's larger corporations and a few Tuaqq import/export concerns. Because of placement of Tuaqq cities and geographic irregularities in the border with the Tuaqq, Mexico City has the easiest access to Tuaqq territory for bulk shipments of goods or resources, and most trade of that type for the rest of Earth is routed through Mexico City.

Like Santiago, Mexico City is distant from other capitals, but the terrain is much easier to get across and the new climate is more hospitable. The high plains of Mexico are used for farming while the hills and mountains are a source of many industrial metals, including one of Earth's few bauxite reserves (aluminum production). These metals are usually shipped to dedicated cities in southeast Mexico, where smelter and refinery runoff into the scrubland sea is out of sight and out of mind.

## Bergen(Norway)

**location:** northeast face

**terrain:** hills

**climate:** warm  
temperate

**borders:**

Tampere(SW, open)

Petrograd(NW, moderate)

Phoenix(S, rugged)

Mexico City(SE, rugged)

Tuaqq(N/NE, rugged)

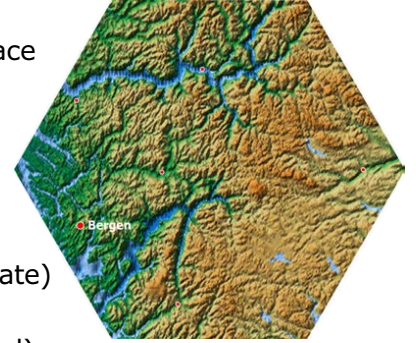

On Old Earth, Bergen was a seaport, set in the lowlands of several fjords, surrounded by mountains. This made it a sprawling, serpentine affair, where parts of the city that were geographically close might be separated by a mountain or water and a long and twisty mountain road, or by a flatter but longer coastal road. During the Exodus, many of the sea-level parts of Bergen were washed away, but the parts on the slopes suffered no more or less than any other part of Earth.

The city rebuilt much in the same way as it was on Old Earth, except it was no long a seaport, but one end of a very long Tampere lake. In addition to being the state capital, Bergen is also the main destination for goods shipped to or from Tampere, Phoenix and Roanoke.

Most of Norway's mineral resources were in parts of that country *other* than Bergen, but there are still nickel and copper mines in some parts of the state. The main mineral export is stone, either crushed or architectural, often transported by barge through Tampere before being loaded onto rail at lakeports near the edge of that state. While not as critical for daily life, Bergen also maintains its significant hydroelectric capacity to both meet high demand on other parts of Earth and as a strategic asset should the Aethos-derived power generation systems stop working for some reason.



## Phoenix(Arizona, United States)

**location:** northeast

**terrain:** hills

**climate:** warm  
temperate

**borders:**

- Bergen(N, rugged)
- Mexico City(NE, rugged)
- Kathmandu(SE, open)
- Canberra(S, moderate)
- Roanoke(SW, open)
- Tampere(NW, open)

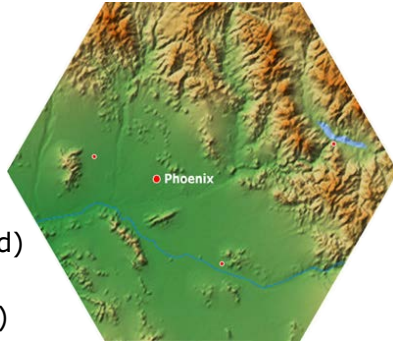

In the 22nd century, climate change and population pressure meant that Phoenix was a city surviving only because of water imports. Very hot and very dry, water was rationed to the point of making many industrial processes impossible and the population of the city had been in decline for decades.

After the Exodus, the area became a fertile oasis by comparison. Unfortunately, turbulent weather in the wake of the Exodus meant that large patches of formerly desert terrain were a new home for countless alien species of plants, mostly Cartoo and Drinn, drifting in as seeds on the wind. Cartoo greasevines, Drinn stickle-grass and all manner of less noxious but still alien trees, grasses and less easily classified species quickly took root. Other states had the same problem to some extent, but none as bad as Phoenix. It took centuries of work and importing *more* alien species to eat the new ones to establish some sort of ecological balance, a juggling act that is a constant drain on the farming economy and lifetime job security for pest controllers. To make things worse, southern Phoenix seems especially habitable to Canberra's poisonous denizens and the combination of the two means the swampy lowlands in southern Phoenix are a nearly uninhabitable morass. Fugitives will occasionally flee into the area to avoid pursuit. The police do not pursue past a certain point, and if the fugitive does not eventually come out and surrender, it is called 'swamp justice'.

## Scrublands

**location:** east and southeast edges

**terrain:** scree, sea, swamp

The eastern and southeastern states of Earth butt up against the windbreak on that side of the polygon. On the west side, these are quite high, exceeding even the Himalayan peaks of Kathmandu by kilometers, while the Rocky Mountains in the southeast corner of Denver are almost even with the top of the Windbreak there. The voids between the windbreak and the states were left empty by the Aeth. Runoff from the windbreaks and rapid erosion from the vertical edges of the states at this edge have turned these borders into treacherous, avalanche-prone boulder fields with rare stable patches of terrain, sliding into the massive triangular lakes generally called the 'windbreak sea' or 'scrubland sea'. The shorelines are uniformly marshy from the constant runoff of soil, but naturally forming river channels have created fertile deltas, which a few hardy colonists (or outcasts) have made a home on. The occasional massive avalanches off the windbreaks generate tidal waves every several years, making life here a precarious balance between the avalanches from the neighboring state or tsunami from the windbreak. The normal compromise is to find a high, rocky spot on the shoreline in the hope that it is elevated enough to deflect *both* hazards. Communities live in these spots, commuting to farmlands by boat or muskipper. Few permanent roads and no railways go into the scrublands, and while data access is available, it is rudimentary by most Terran standards.

Adjacent states usually split the territory evenly, but their population and economic value is low enough that the inhabitants are largely a forgotten population. The scrublands south of Mieres are on the Cartoo border and are either demilitarized or an excessively militarized, depending on how you look at it. Human settlement there is prohibited and every square meter has been programmed into the targeting computers in the emplacements in the southwest corner of the state.



## Colonies

Earth is stuffed into the southeastern corner of this polygon, with neighbors to the north and west, and the Central Sea in the northeast. This means that the easiest direction for those striking out on their own is to the east, south being precluded because no one wants to be close to the Cartoo.

Because of the windbreak height and the geography of Earth, the normal jumping-off point is from parts of Denver. Heavy-lift aircraft will drop a colony as close as possible to their destination and then return home. A colony will usually take several trips to set up, and will almost certainly contract for some number of re-supply flights over the next few years.

If the colony location has been approved by the Terran government, it means that some due diligence has been done to insure that no other race's toes are being stepped on and the colony is given a grant of a certain amount of territory and certain minimal rules that have to be followed regarding dealing with other races. If these are followed, the Terran government will make it known that it will defend the colony as though it were its home territory. This is a very big and very important security blanket for an isolated community of a few hundred or few thousand people, and tends to encourage good behavior in case anyone else moves in nearby. On the other hand, the distance from Earth means that irregularities in conduct are a lot easier to cover up. There have been incidents in colonial history of xenophobic groups massacring or enslaving aliens. In one case, the Terran government had to invade its own colony, arrest, try and execute the leaders of that colony, and then repatriate the rest of the colonists. In the other case, the Terran government let the other alien race know that it disavowed the colony and would not raise a hand to defend it. The results were as you might expect. Video of both of these events (the latter from recon drones) is required viewing for all potential colonists, *especially* colonial leaders.

Unofficial colonies are frowned on, but not forbidden. They simply have zero expectation of protection from the Terran government. Terran private concerns *may* provide security and weapons, provided the Terran government has not prohibited this due to 'impending or ongoing hostilities'. That is, the government does not want to be viewed as defending an unauthorized colony by proxy. If an alien race takes issue with an unauthorized colony and makes a formal complaint, that colony is on its own until the matter is settled. Despite the occasional problem unauthorized colonies are seen as a safety valve for malcontents. If you do not like Earth, you are welcome to leave and live somewhere else. But if you stay, you play by Earth's rules. So, if you have a fringe religious belief, cannot abide the restrictions of 'legal weapons', have a Custom that you cannot openly practice, or whatever else, then you *are* free to strike out on your own.

The first line of defense for a sanctioned colony is itself. Colonies usually have sufficient firepower to discourage bandits or raiders. No raider wants to risk losing a million Eur armored raiding truck to a 500 Eur disposable anti-vehicle rocket. After that, colonial defense is routed through Kat 13, or the Kathmandu 13th Hypersonic Air Wing. With rail launchers high in the Himalayas, a flight of sub-orbital interceptors can be just about anywhere they need to be in half an hour after launch. Of course, at a cost of several million Eur per sortie, there has to be sufficient justification for a launch. However, as a confidence-building measure and good practice, most training missions fly out to an existing colony, 'showing the flag' and familiarizing pilots with the colony and its environs, as well as taking recon pictures to see if there is anything in the area that the colony needs to be notified about.

## Next?

The next chapter deals with creating your adventurers, and contains some more culture and belief-specific information in addition to the normal information on attributes, skills and traits.



7 Minute Speedpaint, by Elias Khasho  
[ehaskhasho.deviantart.com](http://ehaskhasho.deviantart.com)



*The notion of the 'legal weapon' is a statement about the freedom of the individual and at the same time, a recognition that all government is a compromise between what you as an individual want, and what government requires you give up in exchange for what it provides. You are looking forward to adult responsibilities and rights, yet you still rely on your parents for your economic and physical security. This security comes at the price of the sometimes onerous burdens or rules your parents place on your conduct. So it is with legal weapons. Your right to carry is limited by the State based on the security needs for Earth as a whole.*

- Basic Civics, year 8

## INTRODUCTION



By now you should have a pretty good idea of what Aethos is about, a high-tech military/espionage/exploration gameworld with a bit of political maneuvering, competing but incompatible ideas and plans for humanity's future, and *lots* of secrets, some of which might never be revealed. With that in mind, it is time to make adventurers.

Aethos adventurers are going to be slightly better than average, in one of two ways. Your adventurer can either start with superior physical traits and a lesser amount of training (40A and 10S), or average physical traits and better training (35A and 15S). In both cases, adventurers can add up to a total of 10 points from Traits, with the exception of Background, Age and Motivation. Points gained from these do not count towards the 10 point limit from Traits.

The difference between the two types of adventurer is that not all Traits can be used for A and S, so picking the physical type will tend to make you more of a narrowly skilled specialist, while the other type means you may not have as high a skill roll in your chosen field, but you probably have a wider range of skills.

## ATTRIBUTES



All attributes work in the standard way for **Aethos**, including using Fate for luck. Since there are no paranormal powers in **Aethos**, players must provide the gamemaster with a good reason if they want an adventurer to have a starting Fate of higher than 4(1d+1). Starting Fate may never be higher than 6 (2d+0) and the player and gamemaster might want to discuss what weirdness in their background would give them this much Fate in the **Aethos** gameworld.

**!** The upper bound on Fate exempts it from the normal requirement of no more than 3 points of difference between Fate and the next lowest Attribute.

**Quick Attributes:** If you commit yourself to having 40A or 50A spent on Attributes, you can just choose one of the following groups of numbers and just apply it to your adventurer. These sets of Attribute scores cost *exactly* 40A or 50A, and they can be rearranged to suit a particular concept for an adventurer.

40A	STR	AGL	AWR	WIL	HLT	FAT
Strong	10	8	6	6	7	3
Agile	7	10	6	6	8	3
Smart	6	6	10	7	8	3
Tough	8	6	6	7	10	3
Lucky	6	8	8	6	7	5

50A	STR	AGL	AWR	WIL	HLT	FAT
Strong	11	10	8	8	9	4
Agile	8	11	8	9	10	4
Smart	8	8	12	9	9	4
Tough	10	8	8	9	11	4
Lucky	9	9	9	8	9	6





**i** A player decides on a generalist (35A and 15S) and commits to taking 5A in Traits for a total of 40A, then decides they want to take the 'Agile' template. They customise it a little bit by trading the numbers for Health and Awareness, giving them an Awareness of 8 and a Health of 6. Note that some values of the Age trait can get you some of the A you need, so you do not have to take only traits that give you A to get to the 50A level.

**!** An adventurer who is in college or who has a college degree should have an Awareness of at least 8, though this could be handled by having a Forte on an Awareness of less than 8.

## SKILLS

Aethos is a high-tech world, but not so high-tech that players from the 21st century would not understand it. Virtually any skill or profession that exists today on Earth can exist on Aethos, with exceptions and clarifications below.



**free skills** - All adventurers get English (spoken and written) at +0d, the norms for any Custom(s) they have at +0d, and one Area Knowledge of their choice at +0d (this is usually relating to the culture or geography of the place they live). These free skills can be bought up to higher than +0d, as though the adventurer had already put 1S towards the cost.

If an adventurer has a Background making them native to a particular state, they are assumed to be familiar with any quirks of that state's geography, transport systems and so on.

In addition, *all* adventurers of adult age or older will have a mini 'boot camp' package, which is +0d proficiency in the very specific following items, gained during a 'summer camp' study session between their junior and senior year in 'high school'.

- use of KK-511 Terran assault rifle (inc. autofire)
- basic unit tactics and military terminology
- command structure of Terran forces
- using Terran military radios
- driving Terran military trucks

These may be improved from the specific training to a more general skill if desired. This basic training is part of the standard education for adolescents and even if they never go any further than this, *everyone* has it, since theoretically, everyone is subject to conscription laws in time of emergency. These skills are considered important enough in Terran culture that the equivalent of getting your driver's license renewed depends on getting a passing grade in all of the above (which implies that Terran motor vehicle bureaucracies have gunnery simulators). You do not 'graduate high school' without this, so you could not have any college-acquired skills without it. It is possible that an adventurer could have forgotten all they learned, in which case they would get a free 1S, but they would also not have a driving permit of any kind, nor would they be able to rent vehicles or do anything that requires possession of a valid vehicle operating permit.

If the campaign is going to immediately deal with a particular alien culture, the gamemaster may elect to give all adventurers a +0d fluency in the main language of that culture, otherwise adventurers will have to spend 1S to get familiarity in that skill.

The free skills and the boot camp package do not count towards the ten skill limit for starting adventurers.



**firearm skills:** There are several different weapon technologies in use by humans, but for short or medium range use they all act effectively the same, so firing a regular pistol and firing a gauss pistol uses the same skill. Firearms skill is an overall skill, and can be specialized either by weapon technology (regular, laser, gauss, stunner), or by weapon type (pistol, rifle, shotgun).

In addition, there are two main 'enabling skills', which are heavy weapon and autofire weapon. These are +0d skills (cost of 1S) that do nothing by themselves. However, attempting to fire that type of weapon without the enabling skill is done at a -1d penalty. Heavy weapons include cannon, shoulder-fired rockets and the like, while autofire weapons are any weapon used in an autofire or auto-burst mode. The only exception is for lasers, which have zero recoil. Autofire lasers can be used at no penalty without the enabling skill. Those adhering to a 'mountain man' Custom may use archaic muzzle-loading weapons, which have their own enabling skill, but which are otherwise treated as regular firearms. You can for 1S, buy a specialiation that includes the enabling skill for *one particular* model of weapon.

**i** A player buys a +1d in 'Firearms', which normally gives them a roll of Agility+1d to use *any* firearm. However, if they do not have 'heavy weapons', they would lose 1d when using a shoulder-fired rocket, and if they do not have 'autofire weapons' they would lose 1d when using a submachinegun. If the player wanted to tweak their skill, they might spend 1S for a +1d specialization in 'D-34 machine pistol' or 1S in 'M-95 anti-tank rocket'. These would be +1d specializations with those particular weapons, bypassing the need for an enabling skill for that *specific* weapon.

**martial arts:** The exact martial arts of Old Earth no longer exist. Many advanced practitioners of these arts survived the Exodus, but they did not necessarily survive the hardships afterwards. However, the various techniques of Old Earth martial arts did survive in four forms, though they have mutated over the past nine centuries. All are considered Enhanced skills, and fall into the following categories. The maneuvers listed are usually learned as the ones marked '+0d', with the remainder learned in order of skill progression (or gamemaster preference), but any set of maneuvers learned has to have a *net* design cost of zero or more. That is, the skill as a whole (*all* the maneuvers) has a design cost of zero, but any subset acquired *also* needs to be a design cost of zero or more.

**iron fist:** This emphasizes sharp, powerful blows that concentrate as much force as possible into a single point. The basics of the technique are readily available, and aspects are part of advanced military training. Most strikes done with this skill are at increased damage. Buying the skill at +0d is at no restriction. To get advanced training in Iron Fist requires intense physical conditioning, striking hard targets with every part of the body, creating microfractures in bone, that when healed, increase the volume and density of every striking surface. To get a +1d or higher skill in Iron Fist, the person must first acquire a Will of at least 3d+0 with a Forte in Toughness or a normal Will of at least 3d+2. Normally, only dedicated martial artists and elite military forces will have the fortitude to do this. Those with the skill at +1d or more may be trained in how to use special knives to make lethal thrusting attacks using the bonus damage of the 'power fist' maneuver. Such knives are a popular accessory, but those who are not trained in that maneuver take a -1d penalty if trying to use the specialized blade in combat.





## maneuvers: Iron Fist

### iron fist(+0d)

maneuver: strike(thrust)	
enhanced skill	+2
strike+2 damage	-2
maneuver total	+0

### iron arm(+0d)

maneuver: block	
enhanced skill	+2
+2 toughness	-2
maneuver total	+0

### jackhammer(+2d)

maneuver: strike(thrust)	
enhanced skill	+2
strike+2 damage	-2
-2 initiative on kick	+2
lethal damage	-2
maneuver total	+0

**swift reed:** This style is extremely fluid and defensive. While using this style, the person has at least +1 to their dodge in most circumstances. It is almost impossible to do a called shot against a target using this style. Strikes using this style tend to be at normal damage or less. Use of the style is visually distinctive, and you cannot move at more than a walking pace and retain its benefits.



## maneuvers: Swift reed

### drunken strike(+0d)

maneuver: strike(swing)	
enhanced skill	+2
+1 on your dodge	-3
strike-1 damage	+1
maneuver total	+0

### iron heel(+0d)

maneuver: strike(swing)	
enhanced skill	+2
strike+3 damage	-3
-1 skill on kick	+1
maneuver total	+0

### power fist(+1d)

maneuver: strike(thrust)	
enhanced skill	+2
-2 on your dodge	+2
strike+3 damage	-3
+1 skill on punch	-1
maneuver total	+0

### iron spike(+3d)

maneuver: strike(thrust)	
enhanced skill	+2
lethal damage	-2
-2 on your dodge	+2
strike+2 damage	-2
maneuver total	+0

### bobbin weave(+0d)

maneuver: block	
enhanced skill	+2
+1 on your dodge	-3
+1 skill on block	-1
-1 maneuver w/skill	+2
maneuver total	+0

## hornet flurry(+1d)

maneuver: strike(thrust)	
enhanced skill	+2
+1 on your dodge	-3
followup possible	-1
lethal damage	-2
-1 initiative	+2
strike-2 damage	+2
maneuver total	+0

## empty hands(+2d)

maneuver: disarm	
enhanced skill	+2
+2 to Strength	-2
maneuver total	+0

## long touch(+3d)

maneuver: strike(thrust)	
enhanced skill	+2
+2 reach	-2
followup possible	-1
-1 skill on punch	+1
maneuver total	+0

**mirrored path:** This style stresses adaptation to whatever attack form an opponent is using, analyzing it instinctively. If an opponent punches, you punch, if they kick, you kick. As long as you go first and have a held action, you can choose and make your attack a split second before they do, using your knowledge of their declared action to choose the best response.



Fights between evenly matched practitioners of this discipline involve a lot of staring and posturing, ending in a flurry of blows that can leave both combatants incapacitated.

## maneuvers: Mirrored path

### anticipate(+0d)

maneuver: strike(thrust)	
enhanced skill	+2
+1 initiative	-2
followup possible	-1
-2 to your dodge	+2
+1 skill on strike	-1
maneuver total	+0

### simplify(+0d)

maneuver: disarm	
enhanced skill	+2
+2 Str on disarm	-2
maneuver total	+0

### defy fate(+0d)

maneuver: block	
enhanced skill	+2
followup possible	-1
-2 to your dodge	+2
+2 to your skill	-2
+2 Str on followup	-1
maneuver total	+0

### transposition(+1d)

maneuver: move	
enhanced skill	+2
-2 to foe's dodge	-2
maneuver total	+0



## denial(+2d)

maneuver: grab	
enhanced skill	+2
followup possible	-1
-2 to your dodge	+2
+3 to your skill	-3
maneuver total	+0

## final destination(+3d)

maneuver: strike	
enhanced skill	+2
+1 initiative	-2
-2 to your dodge	+2
-2 to your skill	+2
followup possible	-1
strike+1 damage	-1
lethal damage	-2
maneuver total	+0

**tool-do:** Pronounced with the same inflection as 'judo'. Tool-do fighters are masters of turning ordinary objects into useful weapons. Any hard object can be used to do lethal damage. Most can be used as ranged weapons, as well. Tool-do masters can use coins like shuriken, embed a plastic comb in a crack in your armor and then punch it through, or block a sword with a coffee mug and then shove its broken pieces into your eye sockets. Tool-do improvisations may be ruined after a one or two successful strikes or blocks depending on the item.

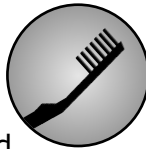

## maneuvers: Tool-do

### crunchage(+0d)

maneuver: strike(thrust)	
enhanced skill	+2
armed or unarmed	-2
lethal damage	-2
-1 maneuver w/skill	+2
maneuver total	+0

### tin roof(+0d)

maneuver: block	
enhanced skill	+2
armed or unarmed	-2
+2 rigid armor	-2
-2 skill with block	+2
maneuver total	+0

### incision(+1d)

maneuver: strike(cut)	
enhanced skill	+2
armed or unarmed	-2
-1 initiative	+1
strike-2 damage	+2
+3 skill on cut	-3
maneuver total	+0

### sureican(+2d)

maneuver: thrown item	
enhanced skill	+2
lethal damage	-2
maneuver total	+0

### tip the scales(+3d)

maneuver: strike(thrust)	
enhanced skill	+2
armed or unarmed	-2
-2 to initiative	-2
-2 to dodge	-2
offset -4 of injury	-4
maneuver total	+0

**law:** For humans, law is a much simpler skill than on Old Earth. The law is uniform across human territory, and there is no difference between state and federal law. The only specializations are for the law as it relates to humans and alien legal systems (or vice versa). Use of legal skills in play are described elsewhere, as are penalties if convicted.

**language:** English (or what is *called* English) is the main human language on Aethos. The language used for the study of ancient books in the *original* tongue is called Old English, which can be bought as spoken and written fluency as a normal skill, or written fluency only at +1d for 1S. There are a number of extant works in extinct human languages like French, German, Russian, Chinese, Hebrew or Arabic, but knowledge of these languages is limited to a small number of scholars, and they have incomplete vocabularies and a large number of words whose meaning is inferred rather than known with certainty. Even the pronunciations are just best guesses.

**!** If someone said to you that they "were delicated by jargogling people through the corrodation of obscure lexicon", you might get all malagrugrous and brabble about it. *Now, how many places would you have to look to find all the words you did not know? And that is for actual English words that are only a few centuries out of common usage. The dead languages on Aethos are three times that old and complete dictionaries for all of them simply do not exist.*

Any of the dead languages can be bought at +1d written fluency for 1S. Because of the physiological differences, someone speaking an *alien* language will *always* sound different than a native speaker. This does not affect fluency, but it means that voice-disguising skills will be useless for languages other than those of your own species. Sophisticated electronics can do a good job of mimicing alien languages in real-time, but these devices do a poor job of conveying emotion, nuance or slang, which is a way that a suspicious person might try to detect their use.



Each of the alien races humans have contact with have their own standard language, which can be bought with full fluency or written fluency in the same way as Old English. Many of the races also have their own dead languages, studied only by their own scholars, and these languages are generally not available to humans except through hired translators from that alien race.

**medicine:** Human medicine is very advanced and virtually everything except aging and loss of brain tissue can be reversed, mostly through genetic therapies and cloned or immune-neutral replacement tissues. As a result, trauma medicine is mostly about keeping a patient alive until they can be gotten to an advanced treatment center. This does not mean that physicians do not have to be well-trained and competent, just that the way they do things is different than it would be in the early 21st century. Medicine is going to be broken down into the equivalent of paramedic or first aid skills, and surgical or hospital-based skills. Both can be Enhanced skills and give the patient +2 to their Health for survival or shock purposes. First aid is about stabilizing a patient, while Medicine is about permanently fixing the problem. Within each skill, they can be specialized if desired. One could be a combat field medic, or be a reconstructive neurosurgeon. Some injuries might not be fixable without a specialist, and some injuries might be beyond a paramedic's knowledge to treat, unless they had a particular specialty. It is assumed that anyone with first aid skill knows about any unique hazards of the region they have spent the most time in. So, if deadly boral snakes are in your home region, you would know basic first aid for a boral snake bite, while someone from outside the area might only know general snakebite treatment.

**!** Note that while the capability of medical care is very high, so can be the cost. The majority of people look at their lifetime coverage limits for state-funded treatment and will often opt for a slower but less expensive regime of recuperative treatments. Do you want to pay for +2 on your Recovery and be a month recovering, or pay ten times as much to be out of the hospital in a week?

**area knowledge:** Everyone will have as a free skill, a +0d familiarity with one broad region (usually a state) or culture (usually a Custom) of their choice. Adventurers can have as many area knowledges as they can afford to purchase. A specific +0d familiarity in an area knowledge is often available as a software package for a smartphone, but this takes more time to use and is only available for subjects of broad enough interest to make such software commercially viable. It also marks you as an outsider rather than a native of that area.

**equestrian:** Horses were most commonly used about a century or two after Arrival, before more technological means of transport were ubiquitous and after enough time had passed that there were enough horses to go around. Nowadays, they are mostly the playthings of the rich on Earth, but low-tech Customs still use them as draft animals, and some fringe colonies use them because they are self-renewing. All of the benefits of human medicine can be applied to horses, but for the most part it takes the form of therapies to prevent cancer or disease, or to repair tissue damage. Even low-tech communities will probably have a cryocooler with advanced therapies for their horses, in addition to whatever they have for themselves.

The only specializations for horses are using them for work such as pulling agricultural implements, or using them in harness to pull road vehicles.



**vehicle operation:** The population density of the human-occupied portion of Aethos, along with its age and technology, mean that there is a well-developed public transport system, and autocabs can pick up and drop off a person just about anywhere that is highly urbanized. So, many people go their entire lives without ever learning to drive a vehicle. Everyone is required to know the basic operation of the standard Terran military truck, but this is of marginal use to most people and does not translate to being able to manually operate *other* sorts of land vehicles.

However, the full range of vehicle skills are there for those who want or need to use them. In addition, most alien cultures on Aethos have their own modes of vehicular transport, and most of these can be operated by humans, once they get used to the differences in controls based on physical differences between the species.

! As you are buying skills, keep in mind what you are going to need. If you are going to carry a 'legal weapon', you probably want at least a +0d skill in using that weapon. If you have any sort of skill involving alien races, knowing their language is a good idea. If you think you will have a **Custom** or two (you probably will), then a skill relating to that Custom is in order. Do not spend all your points or slots for skills until you finish reading up on Traits.

**hobbies:** With the extended lifetimes people have, odds are very high that your adventurer will have at least one hobby for every couple decades of age they have. It might be something athletic like soccer, an obscure social hobby like ballroom dancing, role-playing, playing guitar, whatever. The better you are at it, the more likely it will actually be useful someday.

## TRAITS

Most of the standard traits will apply in Aethos, with a few tweaks and elaborations.

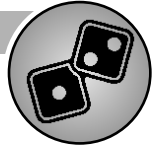

### ● Age ±varies

Most humans have the capability of living to the age of 150, though the decline in ability near the end of life is precipitous. For some, it might start as early as 125, while others make it to 150 before a sharp decline. In any case, the standard **EABA** age breakdown is adjusted for Aethos:

age (Aethos human)	points	maximum
young adult(13-15)	-5A -3S	9(3d+0)
adult(16-25)	+0A +0S	11(3d+2)
physical prime(26-40)	+5A +3S	13(4d+1)
mature(41-60)	+0A +6S	11(3d+2)
middle-aged(61-90)	-5A +9S	9(3d+0)
elderly(91-120)	-10A +12S	7(2d+1)
extr. elderly(≥121)	-20A +15S	5(1d+2)

! Despite the increase range of ages, the points gained for Age are the same as in **EABA**, just as a matter of game balance. As a side note, only adventurers who are in their physical prime or younger at the start of a campaign have a chance to still be alive when Aethos finally turns off its engines in the solar system being approached. This leaves the possibility of multiple generations of adventurers, with the original crew coming back for a last geriatric hurrah for the closing of the campaign.

As a possible exception to the normal rules, adventurers who are middle-aged or older at the start of play may buy an extra level of Status if they also buy *at least* two extra levels of Wealth. *You are established and successful.*

### ◆ Boon/Bane ±varies

Both are highly unlikely. Allergies and other health-based curses have been cured by genetic therapies centuries ago. The boosts to immune systems and the like are normal to all humans and are not considered an advantage.



### ● Custom(new) ±none

The **Aethos** gameworld allows people to have one or more Customs. These have no cost or gain in A or S unless the Custom is unbalanced in some way. The gamemaster can make up several for players to possibly choose from, or let a player come up with their own and then approve or modify it. Customs are meant to let players put a unique spin on adventurers, provided they take some sort of opposing twist to compensate. It is up to the gamemaster to make sure any drawback to a Custom is one that can actually have a chance of biting the adventurer during play. *Customs are part of your public identity.* Anyone can simply query a public database about your Customs if they know your name and enough information to uniquely identify you. Some sample customs, from quirky to straightforward:

**orthodox:** This usually applies to Biblism, but can work with any otherwise mainstream belief. An Orthodox *strictly* follows the belief and in particular follows subsets of that belief which others tend to ignore. This is usually the earliest, 'purest' form of the belief. So, an 'Orthodox Biblist' believes in a patriarchal society. All positions of importance are held by men, women are legally subservient to their husbands, and a near-literal belief in the Prophecies is the guiding principle for one's life.

Orthodoxy is one of the few customs that you can be booted out of by *other* members for failing to adhere to. Most Customs have legally defined bounds that can get you charged for Custom violations, but Orthodoxy violations are judged by the appropriate Orthodox community.

! This means that yes, you can be fined, arrested, or imprisoned for claiming a Custom and then failing to adhere to that Custom's code of conduct and internal rules. Customs are taken very seriously by both their adherents and the human legal system.

**aborigine:** A belief that ownership of land is communal rather than individual. An Aborigine can traverse and sleep on any property they want to without being considered trespassing, provided they are not staying in a structure or crossing the land in a vehicle. However, they cannot spend more than one day on any given property, cannot trespass on military bases, and cannot take more agricultural or animal resources from the land than they can carry. For purposes of the Custom, a 'property' is considered any squatting area that is at least one kilometer away from the previous days' property. So, an Aborigine could roam about a large estate and spend each night on a different 'property', and if the estate was large enough, never leave it. However, there are also well-tested limits as to the number of aborigines in a group, an area or a duration, to keep bands of roving abos from overrunning an area or otherwise becoming annoying permanent fixtures.

**rasta:** A Rasta is someone who believes that they can gain an improvement in some mental function through chemistry, and Rastas range from Bob Marley wannabes out to Timothy Leary types. A Rasta can own, buy, make and use any natural drug or manufactured pharmaceutical they want, or sell what they make to other Rastas. However, a Rasta is prohibited from having a permit to operate *any* vehicle and is subject to stricter penalties for violation of any weapon laws. Rastas are not exempt from knowing basic military truck operation, they just are not allowed to drive them without supervision of a non-Rasta. Rastas are not *supposed* to share, but they are usually open to helping others reach enlightenment, if you know what we mean.



! In strict use, a Custom is its own separate word, but common slang often combines two Customs into one word or has a term that is inferred to mean a Custom or combination of Customs. For instance, a 'Rastalectual' is a Rasta Intellectual, an 'Abosquatter' is an Aboriginal Squatter, but may also be called a 'hobo' for some reason, and a 'PolyCap' is a Polygamous Capitalist, but could also be referred to as a 'sugar daddy' or 'sugar mama'.

**religion:** Each of the accepted human religions (Biblist, Seekers and Joodists) is its own Custom, the Aethos equivalent of the separation of Church and State. Biblists claim one day a week as a day of worship and can require stricter dress, language or behavior codes within their premises, and employers cannot force Biblist employees to work on that day nor penalize them for *not* working on that day. Biblists also are inherently patriarchal, and Biblist women must accept this worldview within Biblist residences, businesses and places of worship (this and other minor limits prevents problems with the small number of Biblist female military officers). There is no formal dress code for Biblists, but those adopting the Custom usually dress modestly.

Seekers have certain dietary restrictions and restaurants cannot fail to serve them because they ask for special food preparation (most major restaurant chains have Seeker and Joodist-approved menu items, and Terran military rations have an approved subset as well). Seekers are exempt from certain place and time restrictions for their prayers. A Seeker could park next to a fire hydrant if it was the only place to pull over when they felt it was time to pray. Seekers do not claim a set day of the week as a sacred one, but do have a sacred month. They can work on this month, but are under certain dietary and conduct restrictions.

Joodists have a separate day of worship, but are otherwise like Biblists in the rights of their Custom. Orthodox Joodists are patriarchal, but most Joodists are not. With the exception of military service, Joodists cannot work on their day of worship. The definition of 'work' depends on if one is a normal, Conservative or Orthodox Joodist. A Joodist could drive a car, a Conservative Joodist could ride an autopiloted car, and an Orthodox Joodist would walk. A Conservative Orthodox Joodist would have to have a good excuse to walk anywhere but to their place of worship. A minor but annoying right of Joodists is that if any two Joodists are in the midst of a debate, any establishment they are in cannot close and must remain open for no more than one hour longer than normal to let the Joodists reach a stopping point in their argument. However, the Joodists are financially liable for all wages of employees on duty at that time, so this right is seldom invoked.

**capitalist:** Capitalists believe in the power of unfettered money. Capitalists can legally do just about anything with money, so long as it is 100% *their* money. They cannot act as agents or proxies for other people's money, and this is enforced based on perception of the intent in any money transfer, not the strict trail of paperwork.

i If you give a Capitalist a 'gift' with an expectation that the Capitalist will use the gift on your behalf, both you and the Capitalist are headed to jail if someone finds out about it.

The only limits are those that affect national security and operation of government, and that use of money in a Capitalist sense is a matter of public record. Violations of these limits on the Custom are dealt with by whistleblower laws that award the whistleblower an award of the money involved, from *each* party in the violation. There *are* small investigative or watchdog groups that finance themselves entirely through whistleblower rewards.





Capitalists can bribe people for favorable treatment, pay to get inside information on stocks, buy and sell things that otherwise might be illegal, and so on. Note that this conveys no immunity to criminal charges for possession of illegal items, but it does convey immunity to charges of trafficking in that commodity. Also, just because a Capitalist cannot get in trouble for bribing someone, the same is not true of the person *being* bribed...

**liberal:** As a Custom, this means someone who feels that the status quo is always in need of improvement. They are closer to 'progressive' than they are to 21st century American 'liberals'. They are not automatically opposed to existing law or Custom, but they cannot oppose something on the grounds that the resulting changes might be bad. Legally speaking, a Liberal business, club or residence may within certain limits have its own specific Custom (only one) that is not necessarily recognized by the rest of humanity, but which has the force of Custom on those premises and only while those who agree to it are on those premises. The limit is that someone already bound by three Customs may not temporarily adopt a new one. Liberal Capitalists tend to dominate the vice trade on Aethos. For those with an open Custom slot, the options are almost unlimited, and because of this, many Orthodox and Conservative groups may *require* members to have all three Custom slots filled.

**i** Someone who is merely an Orthodox Biblist could go to a club where within its walls, the 'Custom' of 'Unfettered Hedonism' is allowed, and they could not be censored by either the Orthodox or the Biblists. Violating their marriage vows on the premises, getting high or shouting blasphemous profanities while drunk would not be a crime or violation of Custom. However, an Orthodox Conservative Biblist (three Customs) would not be able to adopt Unfettered Hedonism, even temporarily.

**conservative:** As a Custom, this means someone who generally supports the status quo. It is *not* 'conservative' in a 21st century American sense, but closer to the term 'reactionary'. For a Conservative, the 'good old days' were the best and the way things should stay. Conservatives will oppose the adoption of new technologies, new social initiatives, even the addition of new Customs. For a Conservative, if it works, it does not need to be tinkered with. Legally speaking, at a Conservative business, club or residence, certain recently adopted Customs, laws or technologies can be prohibited or not granted recognition. And by 'recently adopted', we mean 'anytime within the past two centuries'.

**i** A Conservative-owned restaurant could have a sign on the door saying 'Polysexuals not allowed' or 'The Equal Access Act of year 827AE not applicable on these premises'.

**socialist:** A Socialist on Aethos is someone who believes that the needs of the whole of society outweigh the rights of the individual, whether in terms of property, money or rights under the law. *This does not necessarily mean pro-government.* A Socialist could believe that a large government initiative is on the whole, bad for society, and oppose it on those grounds. All Socialist business enterprises pay half the taxes of other businesses. However, Socialist-owned businesses must be non-profit entities and no person employed by or paid by the business can have an equivalent hourly wage of more than five times that of anyone else in the business.

**i** In order for a Socialist corporation to pay its chief executive a 1,000,000 Eur salary (plus benefits), then everyone else in the corporation must make at least 200,000 Eur a year!

Ways of exploiting this Custom were plugged centuries ago. Most Socialist enterprises are small, local affairs that serve a community need and when they grow too large, they tend to split into smaller groups that work towards the same aim.



**intellectual:** This Custom is sort of an elitist badge. It does not require education, but it does require scoring in the ninety-fifth percentile or above on standard cognitive tests. In game terms, adventurers with an Awareness roll of 3d+2 or more qualify, and this includes adventurers with an Awareness roll of 2d+2 or more and a Forte in analytical ability, or adventurers with an Awareness roll of 3d+2 or more and a Weakness in one or more senses.

An Intellectual acts as though they have a level of Status when debating, arguing or trying to persuade someone in any AWR-based skill the Intellectual has a +1d or better skill level in (they generally get a +2 to their effective skill).

The downside is that people quite rightly think that Intellectuals are snooty smarter-than-thou types, and any sort of contest between opposing Intellectuals usually continues until one of them is temporarily discredited, simply as a matter of honor (you are smart, you are skilled, and you are right, so the *other* guy should back down). A notable subset of Intellectuals are the Rastalectuals. They understand that humans are biologically not equipped to understand the Aeth, but feel that through chemically altering human thought processes, they can gain insight into Aeth thinking without being driven mad. That is, they get high enough to understand something about the Aeth (or think they do), grasp some tiny fragment of that insight and carry it with them when they come down from the high. People will pay good money to hear chemically heightened Rastalectuals argue with each other about things that the audience cannot comprehend, but it is *still* entertaining, especially if the audience is a little high themselves. For arguments somewhat more understandable but almost as entertaining, people will also pay to see a good Joodilectual debate. Liberal Intellectuals and Conservative Intellectuals are mostly just considered jerks.

**squatter:** Among humans, being a squatter is a Custom. This gives the Terran government a way to avoid having to chase Squatters out of these locations, without actually having to take responsibility for their safety. Squatters merely have the right to live according to their own laws within an Aethos portal and free right to cross civilian territory to and from these portals. Squatters are bound by all other laws and Customs outside a portal. Squatters can also tenant any private structure for which private property taxes are more than one year in arrears, but they can be evicted with 30 days notice once those taxes are paid. Squatters in vacant structures have no financial right in the structure and cannot strip it for any parts with resale value. Similarly, if they spend any money to make improvements to an abandoned structure they are not entitled to compensation if they are evicted.

**i** If you spend money to patch the leaky roof and fix the heat pump and the delinquent owner pays the back taxes and evicts you, you do not get anything for your trouble.

It is criminal for Squatters to siphon off public utilities for their use in an abandoned structure, but many of them do it anyway, so long as there are several Squatters and no individual can be blamed for the crime if it is discovered. If they have the money, they will use self-charging exocaps to power essentials.

Because of the recent startup of Aethos' engines, there are a lot of Squatters who have abandoned their portals and are seeking new residence. Because of the increasing population in human territory, some of the larger groups are seeking a way to tenant abandoned alien ruins in distant polygons, which could lead to a number of adventure possibilities.



As mentioned in the previous chapter, you can have no more than three Customs, you must be an adult in order to adopt a Custom, and you cannot exchange one Custom for another more often than once per five years.

There are a number of forbidden Customs, things believed to be of Old Earth but which have no legal status. Knowing the ins and outs of one of these requires having an Unusual Background (e.g. you do not know the full details of the 'Mafia code' unless you or a close family member happens to be part of the criminal underground).

### Enemies **+1 to +4**

There are several groups that are readily available as Enemies, depending on the background of an adventurer and the kinds of grief they are willing to put up with.

**Cartoo:** If you have the Cartoo as an Enemy it means you did something to piss them off in the past, and you are now *persona non grata* in their territory (the Cartoo euphemism translates as 'one to whom suffering is owed'). As a minor Enemy, it means you can only enter their territory under the protection of a more powerful group of Cartoo than the one you offended. As a major Enemy, you cannot enter their territory at all and are likely to be executed if caught and identified. If the Cartoo have any sort of reach, a major pervasive Enemy means that there is the equivalent of a 100,000 Eur bounty on your head, dead or alive, preferably dead. This makes it difficult to guarantee your safety anywhere outside of human-controlled territory, and sometimes even in human-controlled territory. A bounty is generally payable to anyone who fulfills its parameters, so you could be targeted by a human assassin if they think the risk is worth the payoff. Getting rid of a Cartoo enemy is difficult. In general, the only way you can do it is to become powerful enough to reciprocate the level of threat and then pay off the point cost of the Trait.

**TSO:** If you are the investigative sort, or closely associated with such, or you deal in antiquities or obscure information, you might have come to the attention of the Terran Security Office. The TSO is generally only a minor Enemy, and this means that there is a good chance your whereabouts and communications are being monitored. If you have them as a major Enemy, it would mean you are being monitored in real-time, and secondary traces are put on just about everyone you come in contact with, to make sure they are not somehow involved with whatever has drawn the TSO's ire. To anyone with high-level computer skills (6d+0 or better skill roll), equipment or the money to buy the same, a high-level TSO monitoring regime can be detected. And if people find out that anyone you come into contact with is going to suffer TSO surveillance, it can make it very difficult to deal with anyone who is not entirely on the up-and-up.

To have the TSO as an Enemy you must actually come up with your own plot sufficient to warrant their interest at that level. Getting rid of the TSO as an Enemy means stopping the reason for the surveillance and paying off the point cost of the trait.

**!** Since people still use cash and there is a fairly high level of computer tech and reasonable civil rights, it is possible (but not easy) to drop off the map in terms of electronic surveillance. However, all communication accounts (phone, internet, the equivalent of wi-fi devices) require a valid ID to set up, allowing any government agency with a proper warrant to determine the source of a communication. There are proxy services to provide some anonymity for posting to forums and sending emails, but the users of these services must still show ID to the proxy service, so the only way to remain truly anonymous in an electronic sense is set up an illegal false identity. This is not exceptionally difficult, but it is something that will bite you if you are arrested or detained and one of your personal electronic devices was found to have a false identity.



**Aethologists:** If you have been a vocal critic of Aethology, revealed any of their secret doctrines, or caused them any public embarrassment, you will have Aethologists as an Enemy. At a minor Enemy it means that whatever public means are available will be used to identify you to other Aethologists. For instance, every Aethology center on Earth will have your picture, known aliases, email accounts and so on. You will not be welcome at their facilities, you will not be able to register on their online forums without having a false email account, and you can expect your car to get scratches and flat tires with distressing frequency if it is parked someplace not covered by a security camera. As a major Enemy, Aethology is out to get you. They will investigate your credit rating, hire private detectives to dig through your trash and tail you to see if you are cheating on your spouse. If you run for public office, they will financially support your opponent. Any time you make a public statement, you can count on editorial ridicule by someone of importance. If your job involves any sort of secrecy or subterfuge, you can count on it being sabotaged by any legal means available. Getting rid of Aethology as an Enemy involves finding something more offensive for them to focus their attention on and then paying off the point cost of the Trait. While they can be obnoxious rat-bastards, they are generally as good as their word. If you can convince them of a greater threat to their beliefs than you, then they still will not like you, but they will be willing to pay the price of ceasing their harassment in exchange for a full identification of that threat.

#### **Favors** -1

With the number of factions and Customs and alien races, there are plenty of ways to accumulate favors. Players who wish to start with Favors or the benefit of them should not spend more than 2 points on them. A Favor is how you would start play with something that is not illegal, but which you really should not have been able to acquire.

#### **Forte/Weakness** -1A/+2A

Humans on Aethos are not uniformly perfect in a genetic sense, but the level of variation is far less on the negative side. It is much less likely that anyone will suffer from congenital blindness or deafness, or even that someone makes it to puberty without having near- or far-sightedness permanently corrected. However, there remains a tiny minority for whom the genetic fixes just do not take. This can be reflected in a Weakness like vision problems, nerve or bone damage that could not be entirely fixed (a limp) or problems with modern medicine (a penalty on Health when recovering from injury). Or it might be something as simple as having exhausted your lifetime medical benefits and being unable to afford to get the problem fixed.

#### **Friends** +1 to +4

Friends can be in almost any group or organization, but to be worth spending any points on, they need to have some power, authority or reach that they can and are willing to exert on your behalf. This can be above and beyond the normal bounds of any authority an adventurer might have and the actions of Friends can be illegal. Both Friends and favors should be given a little background to explain why you have them. You cannot just say "The government owes me a major favor". You would have to say something like "The TSO deputy director owes me a big favor, because my adventurer was the private investigator who cracked the kidnapping of his daughter, and my adventurer took two bullets in the process of helping rescue her."



## ◆ Larger than life -2P/-5P

Humans in Aethos have no natural ability to be Larger than Life on any Attribute or skill. The Aeth have the ability to a high degree, and it is possible that some of the other surface races have the ability for one Attribute and its related skills. None of humanity's immediate neighbors on Aethos have the ability naturally, though the Cartoo use cybernetic enhancement and it is possible that advanced devices might grant a 'best four' roll for very specific tasks (a cyborg arm might be superhumanly fast, or an advanced weapon sight might allow a Cartoo sniper a 'best four' weapon skill roll).

Keep in mind that starting adventurers have no P to spend, so they need to take traits that would give them these points and *also* get gamemaster permission for the trait.

## ● Looks ±1S

Applies normally, but only within a race. One would have to be exceptionally disfigured to look out of place among your kind to an alien observer. And in an era of relatively cheap regen therapy, a negative looks would almost have to be a deliberate decision which likely has an interesting personality trait or two to go with it.

## ● Motivation +1S

Motivation is always an easy 1S towards an adventurer, but it is not required in Aethos.

## ◆ Mythic Archetype special

If you have a group that meets the trait requirements, go for it.

## ◆ Organization -varies

There are plenty of organizations adventurers can be part of, but starting one of their own should be something that is developed with experience gained during play.

## ■ Permits -1S

As mentioned in the previous chapter, carrying anything larger than a legal weapon may be restricted in some cities. Similarly, just because you know how to operate a class of vehicle or a piece of equipment does not mean you are certified to do it *commercially*, like the difference between being a private pilot and a commercial pilot. Most permits have a competency exam and skill requirements. In game terms, this will translate to *at least* a +0d level of bought skill *and* a skill roll of at least 3d+2. If other people's lives are going to be in your hands, you need to be passably competent. For legal ownership and transport of weapons, the same thing applies. Even for weapons in the 'legal weapon' category, you must still show competence in its use. The requirements for various weapon permits:

- **legal weapon(pistol):** 3d+2 skill roll
- **legal weapon(rifle):** 3d+2 skill roll
- **autofire weapon:** enabling skill for the weapon
- **explosives:** 3d+2 skill roll in Demolitions
- **grenades:** 3d+2 skill roll in the enabling skill for heavy weapons *and* be a military veteran
- **heavy weapon (direct fire):** 3d+2 skill roll in heavy weapons *and* be a military veteran

! Note that the 3d+2 skill requirement for a legal weapon permit is a permit to use it *commercially*, like as a bodyguard, which allows you to carry concealed in places where unpermitted legal weapons would have to be surrendered. This is subjective and business-dependent. For instance, most trains require surrendering legal weapons at the door and they are returned when you disembark, but permit holders may retain their weapons. Airlines, however, usually require surrendering all lethal weapons, permitted or not. A permit does not let you violate a business or individual's set of rules for *their* property. The permits for the other weapons listed are simply for *ownership*.

! Anyone with a +0d skill *and* a skill roll of at least 2d+1 can carry a legal weapon for personal defensive use without the need to worry about liability problems and without a permit.



Commercial permits for equipment or vehicles cost 1S each and are good anywhere in Earth territory. Permits for concealed carry or *loaded* transport of weapons other than legal weapons are generally 1S each and are only good in a particular state, with a limited amount of reciprocity (your Philadelphia permit might also be good in Ankara). This would *not* give you permission to tote around grenades or rocket launchers. Spending 5S would cover you for virtually all of Earth's territory and enclaves. Having a permit of a particular type also gives you a basic knowledge of the regulations associated with that permit. A commercial trucker knows the regs about how many hours they can spend on the road per day, a backhoe operator knows who to call before digging to make sure there are no buried utility lines, a weapon transport permit means you know the legal way to transport that weapon, and so on.

❗ To recap, *personal use of legal weapons requires no permit, nor does ownership or unloaded transport of a non-military weapon require one.*

### ● Personality +varies

Aspects of Personality are as normal under the rules. While Customs are worth no points, people who take Customs often have strong personal beliefs and these beliefs *are* levels of Personality that are worth points.

It is *recommended* that for each Custom taken, the adventurer has to have at least 2P in a personality trait or traits that mesh with that Custom. The guidelines in **EABA** on motivation and priorities for extras are a good starting point. For instance, an Orthodox person will have a high value on 'faith' or whatever the core value of the thing they are orthodox is about. For a very orthodox person in Aethos, this core value is probably more important than their wealth or family. For a Rastalectual, seeking enlightenment is more important than their personal safety, either as a matter of circumstance or what they are doing to their own body. *You take a Custom because it reflects who you are.*

### ● Probation(new) +varies

This is really just a special case of Personality. An adventurer with a past conviction for a serious crime may have one or more behavior modification implants, genetic alterations, or merely legal prohibitions from doing certain things, as described in the previous chapter. These are strong enough that violating them is next to impossible (a difficulty of 18 on Will), or that violation of them immediately causes 4d+0 non-lethal damage (like a convicted violent felon going into seizures from picking up a gun). These are *not* ultra-tech cyber implants. Instead it would be something like a bracelet or anklet with some smartphone and sensor capability, or a prescription and regular checkups to make sure you are taking it. Serious cases could reinforce this with some brutal drug-enhanced aversion therapy.

Being on probation is worth 2A or 2S and the effect wears off or can be legally removed in a year from the start of play. Each time this is doubled is worth an extra 2A or 2S.

i Because of multiple crimes involving underage farm animals and public decency laws, your adventurer is banned from the city of Philadelphia for the next four years. This is two doublings of the default one year sentence, so this Probation is worth 6A, 6S or some combination that adds up to 6 points.

When the time interval has expired, the person on probation applies for legal rehabilitation, and the processing time for this is about a month. When reversed, the penalty is gone, and the player does not have to use any experience points to make up the difference. *The sentence has been served.*

❗ Anyone on probation has to check in regularly with their probation officer (or designated alternate if travelling) to confirm that all Probation-related modifications are still intact and operating. A prolonged absence from Earth territory is not inherently criminal, but failing to promptly check in after return is. Violation of probation can result in an even harsher sentence.

**Secret** +1 to +4

There is always the possibility an adventurer could have as aspect that they really do not want to become public knowledge. Here are a few in Aethos:

**personality:** Most consensual behaviors are legal, but that does not mean that all Customs approve of these behaviors. For instance, most Biblists disapprove of same-sex relationships, so a Biblist having one would be keeping a secret from other Biblists.

**spores:** Spores are a leftover from the earliest years after Arrival. While they are not contagious and exposure confers immunity, there is a certain stigma associated from having had them. This is a minor Secret and if it is found out, the adventurer must either make up the lost points through accumulated experience or suffer the same number of points as a form of negative Status. More detail on spores is on [page 7.7](#).

**enemies:** Having either Aethologists or the Terran Security Organization monitoring you could be a minor Secret. Having it exposed would require the adventurer to either make up the lost points through accumulated experience or suffer the same number of points as a form of negative Status. Loss of Status in play would normally be associated with a major setback of some kind. An investigation into criminal activity could be fritzed if people find out you are being monitored by the TSO. If your boss gets his tires slashed because you are on an Aethologist enemies list, you might get fired.

**Status** ±varies

A adventurer's default status is average for Aethos, typically the equivalent of a middle-class citizen in terms of their rights, duties and privilege. Status that adventurers can start the game with will vary. A military veteran with an honorable discharge is 1S and is a limited form of status that only applies with other veterans or active duty personnel, usually in a social sense, though it is also a requirement for certain types of weapon permit (you *also* have to spend *at least* 1S to upgrade one of your free skills from boot camp). One particular form of very limited Status is a 'security clearance'. This does not convey any extra pay or public respect, but may be required to have certain jobs or know certain information. In particular, to know most of the true history of humanity on Aethos requires a level 2 security clearance (two levels of very limited Status). Security clearance is inherent in full levels of Status, such as full Senators have. To know *really* secret stuff requires levels of security clearance at gamemaster's discretion. Adventurers may not start play with more than a level 1 security clearance.

**Unusual Background** -1

There are not too many unusual backgrounds in terms of how this Trait is meant to work. An adventurer with an atypical physical trait, or who is in possession of something unusual, whether tangible or just information, might need an unusual background, at gamemaster discretion. For instance, if you know something you have no right to know, maybe it was something you saw or overheard as a child, peeking through a hole in the wall during a meeting between your late grandfather and a bunch of scary men you had never seen before. What you saw and heard changed your life, even if you never told anyone about, and this knowledge let you find out other things you probably should not know, and this has gotten you into no end of trouble.



## ● **Wealth/Poverty** **±varies**

Wealth in Aethos has a few quirks. First is a person's medical allowance. Unless otherwise noted, all adventurers are assumed to start play with all 300,000 Eur of their medical allowance intact. Having significantly less than this amount is a form of negative Wealth. Each 50% less than the full amount is worth 1S. It means you have had some sort of expensive medical treatment or are just old enough that you are using it up. This is a fund that is independent of normal living expenses and income and is just kept track of rather than using savings boxes. Getting points from dropping your medical fund means you may *not* spend points to give your adventurer any extra wealth. Adventurers can set up their own private medical accounts, but cannot add to the government supplied amount. That is simply a fund that goes down with use and never goes back up. To keep adventurers 'hungry' we recommend that no more than 2 levels of increased Wealth for starting adventurers.

Otherwise, starting cash and goods and lifestyle and expenses are determined normally. Of a person's starting goods, they are assumed to have bought an apartment or house. 'Buying an apartment' means that you have a *permanent* ownership interest in a certain amount of floor space in an apartment building. This has about the same cost in savings marks as a regular house, generally because apartments are more urban and desirable from the standpoint of being close to interesting places. An apartment has a monthly fee as your share of building upkeep (which is subsumed in your lifestyle rating).

Apartments that are rented merely on a monthly or yearly lease are less common and generally of the lower quality sort, though high-end monthly or yearly properties are available for highly paid contract workers and the like. These apartments have no cost in starting savings, and an upkeep cost the same as owned housing.

It is expected that you will, if you have a job, be living at the standard of living appropriate for your income, with enough left over to accumulate some savings.

Remember that lifestyle rating covers almost everything you would do as a part of daily life in a given area. If you are a member of the elite class, then a 200 Eur dinner bill at a five-star restaurant is par for the course, while if you are lower class, 200 Eur feeds your entire family for a month. The social circles you can freely move in are limited by your monthly expenses. If you are not making the money you used to but still want to hobnob in the same social groups, the same professional contacts and so on, you need to spend the same on monthly expenses, even if you are not making enough to replenish those funds.

**i** If the person you need to meet is going to be at a posh formal party, you need to look and dress the part if you are going to meet them, and of course, appear to be enough of a 'someone' to get invited in the first place. A down-on-their-luck has-been does *not* get invited to this sort of affair.

Adventurers who are employed or employable but with a skill level for income generation of 2d+2 or less are assumed to be on the dole. Terran citizens are provided for at subsistence levels, implemented by a special ID card that gives a monthly allowance for food, clothing and transport. These allowances can only be spent at places that handle electronic payments, and can only be spent by a specific person on a limited set of things. So, your food allowance cannot be spent on beer, your clothing allowance on jewelry, etc. Public housing is similar to US-style 'project housing'. Better managed, but old, drab and cramped. *Beggars cannot be choosers*. Being on the dole is either a negative level of Wealth or a negative level of Status, depending on whether you are competent but cannot hold a job, or are so unskilled that simple physical labor is your only employable talent.





As a reminder, starting income (assuming you have a job), savings and assets are based on the dice in your best employable skill, minus 10, adjusted as per the guidelines on **EABA** page 3.45. The minimum adjusted lifestyle is -8, and you cannot take negative levels of Wealth or other adjustments to lifestyle that would drop it below this amount.

Remember that being in a high-demand profession boosts your lifestyle rating, while being in a low-demand one drops it. A neurosurgeon with a skill roll of 6d+0 makes more than a garbage truck driver with a skill roll of 6d+0. The gamemaster can say that certain professions that are traditionally high-paying require the adventurer to pay for a level of Wealth to reflect this, depending on their age. A gifted neurosurgeon who is still an intern has a better excuse for a lower income than one who is in his fifties.

### Starting goods

Some generic costs for big ticket items are on the list on the next page. In general, even a lower-class person can cover a few sets of clothing, some luggage, maybe a decent piece of concealed body armor, a legal weapon and a universal transit pass for the next month (unlimited bus or train fare). This makes you a person living out of a suitcase with no fixed address, but maybe that is how you *want* your adventurer to start play.

Anything that is a reasonable tool of how you make a living should be accessible to you. Even if you forgot to write it down before the start of play, you should be able to acquire it at little or no cost. Within reason. A pilot does not get a free plane, but they would have a full set of nav software, possibly a dedicated avi-comp and a few spare uniforms if they are a commercial pilot. If you are ex-military you probably have a gun cleaning kit. And so on.

*Do not fret over the small stuff.*

The only thing that you should take into account, not just for **Aethos**, but *any* rpg is “how reasonable is it for my adventurer to have this piece of gear?” For instance, right now in the real world, you *can* go out and buy a neat thermal imager or gyrostabilized binoculars or a satellite phone. But, these things are fairly expensive and while a lot of role-players might think these would be *really* cool gadgets to have, very, very few *actually* have them. Because the actual utility of having that gadget is not matched by the money you would have to spend. Instead, you have a cheap pair of department store binoculars and a cell phone. Your adventurers in Aethos are within the Aethos framework, ‘real people’. Just because they *can* plunk down 1000 Eur on a pair of digital binoculars does not mean that they have done so. It may come to pass that a pair of these will come in really handy on a regular basis later, but for now the adventurer does not see a need for it and is saving up the money for a vacation or a new laptop or making rent payments.

So for now, get only what you actually need and regularly use for your chosen profession, get some of the generic gear below and work out the actual details once you get into play and see what you missed. Remember that any boxes marked off your initial savings are for things whose cost on the gear list exceeds your lifestyle, and that many goods will have a higher starting cost in **Aethos** because of higher raw material and labor costs.

**i** If you have a lifestyle of -5, then anything related to your work or skills that has a cost of -5 or less will not cost you any savings. Anything that costs -4 or more uses that number of savings boxes.



## SAMPLE ADVENTURER

We are going to throw together the adventurer mentioned in the opening vignette, Carson Protonotarios. We will work his background into the description and assume that this is one of his Traits, with other Traits of note in boldface.

Carson is an **adult**, a recent college graduate with a journalism degree (and a minor in history). His family history is mostly Greek, and his name dates back to a prominent Greek family of some notoriety in the first century after the Exodus, though like many such families, any benefit of the famous name has been diffused to a footnote by the passing of time. But it does give the gamemaster a hook to draw Carson into plots involving ancient history or conspiracies in which his ancestors played a major part.

Since no part of Greece is on Earth, the player says Carson's most distant ancestors were on a yacht at the time of the Exodus, and the rumored family history is that they were smugglers of some kind.

Carson is pretty smart and fairly fit, but does not have a lot of depth to his skills nor a lot of experience with the world at large. He currently has an entry-level job with a Philadelphia news agency, but is looking for something better than handling garbage assignments that senior staff does not want to be bothered with.

As an adventurer, Carson is built on the 40A/10S point allotment, and for the sake of speed, the player chooses the 'smart' Attribute template and makes some minor adjustments:

### Carson Protonotarios

Strength	2d+1 (+1 more than listed)
Agility	2d+1 (+1 more than listed)
Awareness	3d+1
Will	2d+1
Health	2d+2
Fate	1d+0

generic Aethos gear	cost
lower-class clothing, accoutrements	-2
lower-class housing*	+10
middle-class clothing, accoutrements	+0
middle-class housing*	+13
upper-class clothing, accoutrements	+4
upper-class housing*	+16
mobile phone/computer	-2
laptop computer/tablet	+0
desktop computer/workstation	+2
home entertainment system	+2
minimal self-defense gear (pistol)	-3
minimal body armor	-3
hunting gear (w/rifle)	+4
expedition gear (w/camping)	+2
paramilitary gear (w/assault rifle)	+7
transit pass, 1 year	-4
urban vehicle parking, 1 year	+2
secure storage (auto size), 1 year	+2
scooter	+0
motorcycle	+5
compact car	+8
sports car	+11
luxury or high-end sports car	+13
personal off-road vehicle	+4
off-road auto or truck	+11
(for most items) lower quality	-2
(for most items) better quality	+2

\*The cost to *maintain* housing is a weekly lifestyle cost appropriate to its quality, which is usually about the initial cost minus 17.

**i** Our sample adventurer is going to live in lower-class housing. His income is -5 and his weekly condo upkeep fees (utilities, groundskeeping, taxes, etc.) are -7, well within his expense limit. Even if he lost his job, he has a passive income of -6, which is enough to cover the rent as long as he keeps all his other weekly expenses at a minimum. In terms of cost levels, doubling the money you spend is +2 cost levels, so spending -7 (90 Eur) twice (one on upkeep and once on a fancy dinner) would put him at a total expense of -5, which is *higher* than his passive income of -6 and would cost him a box of savings. If he is employed and has an income of -5, he stays barely staying within his budget doing this.



This costs 40A, so this is covered by the initial allotment for attributes except for the small amount the player wants to boost them. Carson has 10S left for skills or other traits. The player decides to give Carson the aforementioned **Age** (+0A, +0S), a decent **Background** (+1S) for Carson, and his uncle the odd archaeologist as a minor **Friend** (-1S), and adopts the Customs to make him a Socialist Intellectual, the former because it is what he believes and the latter mostly because he thinks it will help his career.

He leaves the last Custom he is legally allowed open, since he has not found any he is ready to commit to. For **personality**, he takes two levels of 'curious' (+2S) and one level of 'elitist' (+1S). The latter might get him into more trouble than the former, but he is smart and college educated and is young enough to think he knows the answer to questions that smarter and wiser people have been trying to answer for generations.

To add a little character and to get Carson the rest of the A points he needs to pay for his Attributes, Carson is on **Probation**. As an undergraduate, he got amazingly drunk one night, got behind the wheel of a car, turned off the autopilot and ended up doing a lot of property damage. *The courts suspended his license*. Carson is not allowed to manually pilot any powered on-road vehicle for the next two years (worth +2A and +2S).

In fact, all on-road vehicles will read his ID and refuse to start if he is in the driver's seat unless he hits the 'override' button, which also places a call to the police informing them of the probation violation, the vehicle description and the location of the event. Note that he could choose to *not* carry his ID, but a vehicle will automatically send a minor alert to the authorities in such cases in the event someone wants to check up on it. Note that not carrying an ID is not actually a crime, but *is* inherently suspicious. Those who have a middling degree of paranoia about such things have RFID-blocking wallets, so they can flash an ID when needed, but keep it hidden from electronic scans when they do not.

! We are giving him +2A/+2S for the probation because Carson wants to boost his Strength and Agility from 2d+0 to 2d+1, and needs 2A to do this.

Carson's background as written by the player includes some tidbits of his family origins in a transplanted part of Greece, his unfortunate encounter with the law (and his vehicle's encounter with some headstones and a church), the uncle who took a distant but paternal interest in him after his parents died in a plane crash (presumed an accident, but these things can change in play), and what Carson wants to do with his life. The notion of a new Arrival has altered his ambitions. Carson is looking forward and back. He wants to know, document and if possible be part of humanity's contact and even exploration of whatever new world Aethos is about to encounter, and he wants to dig into humanity's past, to compare it to whatever the inhabitants of the new system are going to experience. He has vague ideas about a huge literary project that will take decades to research and complete, but his most immediate concerns are trying to get a job that is more than being a paparazzi. Though, that does get him close to a number of interesting people and as long as he does not use the camera, they are not overtly hostile towards him...



His specific goals we will count as a Motivation for +1S. Doing this could be dangerous. This is setting Carson on a course that he will not be swayed from, even under threat. It is his *motivation*, his reason for existing.

Since we already mentioned that his parents died in a plane crash, we are going to put -2S towards increasing Carson's **Wealth**, most of which is in the form of investments, a trust fund that guarantees him a certain income, even if he is not employed (the player rightly thinks this could be handy). So, we have:

campaign base	+40A	+10S
attributes	-42A	-
age	+0A	+0S
background	-	+1S
friend	-	-1S
motivation	-	+1S
probation	+2A	+2S
personality	-	+3S
wealth	-	-2S
remainder	+0A	+14S

Note that the Probation and Personality use up 7 out of the 10 points he is allowed to *gain* from traits for this setting. Knowing that we have 14S for skills, Carson gets:

journalism(+2d)	-4S
history(+0d)	-1S
ancient English(+0d)	-1S
running(+0d)	-2S
firearms(+1d)	-2S
brawling(+0d)	-1S
photography(+0d)	-1S
area kn.(politics)(+0d)	-1S
<b>total</b>	<b>-13S</b>

Carson also gets his language and an area knowledge as free skills, chooses automobile as his native culture skill and has the normal 'boot camp' package.

'Journalism' is not a defined skill in **EABA**, but we can make some assumptions about how it is used and when he would make rolls with it. Carson knows how to do interviews, is passably good at writing an engaging story, knows how news organizations work, is familiar with digging through bureaucracies and public records, and so on. With a skill roll of 5d+2, he is actually very good at it for someone his age, and he knows it, something which is not lost on or appreciated by his older and perhaps less skilled colleagues (remember, Carson is slightly elitist and a registered Intellectual).

## Aethos<sup>1.0</sup>

Blacksburg Tactical Research Center

<b>Name</b> Carson Protonotarius	<b>Gender</b> M	<b>Age</b> 23	<b>Stam</b> 1	<b>Hits</b> 1
<b>Background</b> Reporter & photographer			2	2
<b>Goals</b> Write the big book tying all of human history together			3	3

**Strength** 7 2d+1

carry

strike 1d+1   kick 2d+1   throw 1d+1

strike

throw

**Agility** 7 2d+1

fight

fight 2d+1   balance 2d+1   throw 2d+1   dodge 4

balance

throw

**Awareness** 10 3d+1

cognitive

think 3d+1   spot 3d+1   listen 3d+1

sight

hearing

**Will** 7 2d+1

toughness

tough 2   charm 2d+1   resist 2d+1

charm

resistance

**Health** 8 2d+2

speed

walk 5   run 7   sprint 9   recov 0

stamina

recovery

**Fate** 3 1d+0

shield

power 1d+0   luck 1d+0

1 3 5 7 9

11 13 15 17 19

power

luck

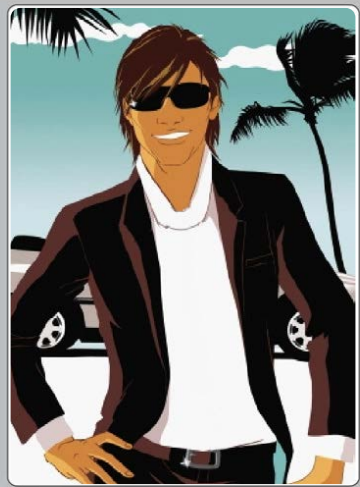

<b>head</b> d+ 3-6	<b>torso</b> d+ 9-12	<b>arm</b> d+ 7-8	<b>leg</b> d+ 13-18
--------------------	----------------------	-------------------	---------------------

**Gear** **weight**

Clothing(business)	-8
Phone	-
Laptop	-10
Pistol	-12

**Lifestyle** -5   **Invested** -6

**Savings** ●●●●●●●●●●

Traits	value
Adult(age 23)	0A/0S
Background	1S
Friend(uncle)	-1S
Motivation(be a historian)	1S
Personality(curious, +2)	2S
Personality(elitist, +1)	1S
Probation(no manual vehicle)	2A/2S
Wealth(+8 savings)	-2S
Press pass(v.limited Status)	-1S
Socialist Intellectual(Custom)	-

1	1	1	1	1	1	1	1	1	1
2	2	2	2	2	2	2	2	2	2
3	3	3	3	3	3	3	3	3	3
4	4	4	4	4	4	4	4	4	4
5	5	5	5	5	5	5	5	5	5
6	6	6	6	6	6	6	6	6	6
7	7	7	7	7	7	7	7	7	7
8	8	8	8	8	8	8	8	8	8
9	9	9	9	9	9	9	9	9	9
10	10	10	10	10	10	10	10	10	10
11	11	11	11	11	11	11	11	11	11
12	12	12	12	12	12	12	12	12	12
13	13	13	13	13	13	13	13	13	13
14	14	14	14	14	14	14	14	14	14
15	15	15	15	15	15	15	15	15	15
16	16	16	16	16	16	16	16	16	16
17	17	17	17	17	17	17	17	17	17
18	18	18	18	18	18	18	18	18	18
19	19	19	19	19	19	19	19	19	19
20	20	20	20	20	20	20	20	20	20
21	21	21	21	21	21	21	21	21	21
22	22	22	22	22	22	22	22	22	22
23	23	23	23	23	23	23	23	23	23
24	24	24	24	24	24	24	24	24	24
25	25	25	25	25	25	25	25	25	25
26	26	26	26	26	26	26	26	26	26

©2013 BTRC



Carson has 1S unspent. He does have room to take up to 3 more points in traits if he wanted to, but we have him reasonably fleshed out as is. One thing Carson might consider taking a trait to pay for is a 'press pass', which is an extremely limited form of Status or Permit that can get him in some doors that would be closed to others. The gamemaster says he can have that for 1S, since he has the training and is for the moment, employed in that role. That is, other adventurers could not just buy press passes, since they are not working for an accredited news agency.

If we use normal **EABA** amounts for income and such, Carson has a lifestyle of -5 (in the lower class range) and savings of +14 (+6, but with +8 from extra Wealth). We have said Carson has put this extra into his investments. The default for investments is (savings - 24), which would drop savings to +13 and give Carson a passive income of -10. We do this 4 more times, giving Carson a passive income of -6 and a savings of +9. What this means is that even if he is out of work, Carson makes enough from the trust fund (-6 lifestyle) to maintain *most* of his working lifestyle (-5). Combined, he can live at a better level than his income normally allows, so he has some discretionary income for gadgets and travel and such without dipping into his savings, which are also pretty good. Carson's lifestyle of -5 means that each of his savings boxes is worth about 175 Eur and he has about 7,900 Eur in the bank (45 savings boxes).

Carson's initial situation is that he is living slightly better than he ought, having splurged for a better location for his apartment, and covering the extra lifestyle cost with savings or spare investment income. Since he lives in an urban area and is not allowed to drive, he has a transit pass to get him where he needs to go. He has a pistol 'just because', even though he does not regularly carry it, a nice computer or two and various items related to his trade. Whether or not Carson's future will make him wealthier or poorer is unknown at this point...

To add a little flavor to Carson's possessions, the player says that Carson wants to drive, though he is legally prohibited from it at the moment. In his spare time he collects vintage motorcycle parts. He has not got the skills to put anything together (or drive!), but one of his long term goals is to pick up enough skills to restore a classic bike from the previous century and have it ready to ride by the time he gets his license back. This gives Carson an excuse to travel to odd spots to pick up parts, a secure place to store things other than his apartment (lifestyle cost of -9 for rent), some power tools and eventually maybe an excuse for the player to create a 'Biker' custom that Carson might adopt. And yes, this *would* make him a Socialist Intellectual Biker...

Carson's gear	cost	savings
lower-class housing(rented)	0 Eur	-0
middle-class clothing, etc.	1000 Eur	-6
pistol	350 Eur	-2
transit pass	250 Eur	-1
phone	500 Eur	-3
laptop	1000 Eur	-6
home computer	2000 Eur	-11
motorcycle parts	1000 Eur	-6
total	6100 Eur	-35

Nine boxes drops his remaining savings from +9 to +8, eight more to +7, and so on, down to a final savings of +4 with no boxes spent.

**!** Note that we used the guidelines on **EABA** page 3.47 to turn 'savings boxes' into cash equivalent (7,900 Eur), and bought all his gear as its equivalent in 175 Eur savings marks. How you choose to handle the bookkeeping for your adventurers is up to you.

As an adventurer, Carson has a lot of room to grow. From the gamemaster standpoint, he has some useful skills, a personality that can get him into trouble, a past with just enough hints that there is something else going on that he could eventually get drawn into, and simple but interesting long-term goals that add a bit of character to him.

## NEXT UP

As a player, by now you should have everything you need to get into the world of **Aethos**. What remains is the circumstances by which the gamemaster starts things off, and how your adventurer relates to or first encounters the other adventurers. You might be travelling together by coincidence, and circumstance forces you to work together, a relationship that continues later on. Maybe you all work for the same person, directly or indirectly and you were chosen as a team without even knowing it. An opening adventure is both 'getting your feet wet' and laying the foundation for future events.

One thing that is entirely reasonable is that your adventurer might not work exactly the way you want. Not being perfectly suited to the gameworld is one thing. *None of us are perfectly suited to the real world, either.* What we mean is that there may be certain aspects of the adventurer that you as a player are unhappy with. Maybe you decide you need just a little more Strength. Maybe your primary skill just is not as good as you thought. *Ask the gamemaster.* Maybe you can rearrange things or take a new trait for a point or two to make the adventurer someone you will have more fun playing.

Also, after the first adventure or game session is a good time to start writing down the actual gear your adventurer owns and what they regularly have close by. A lot of things are assumed, but the more you get into play, the more likely you will want to know *exactly* what model pistol you have, how far you live from the other adventurers, the details of Friends and Enemies, the sort of thing that may have been rough outlines at the start of play, but which will become more important later on.



The next chapters deal with the alien races on Aethos and overall campaigning and is mostly for the gamemaster, but the last chapter deals with gear and other goodies to keep you occupied and drain your bank account.

As you get ready to play, start thinking about what it is you want from the campaign, from the standpoint of you as players, and the goals of your adventurers. This is a campaign and a gameworld that can run for a century of game time, and adventurers will not be out adventuring the whole time. There will be breaks in the campaign that could be *years* in length. Adventurers could get a college degree between adventures, get married and start a family, change Customs, get promoted, join the armed forces (or leave them), and so on.

A person in Aethos generally does not say "I want to have adventures", rather, adventures are something that just *happen* while you are trying to live the rest of your life. Some careers have more excitement, danger and adventuring possibilities than others, but the goal of most people is to live a long, happy and hopefully prosperous life. There are plenty of heroes in the game history of Aethos, and while their deeds were laudable, their post-heroic lives did not always turn out well.

So, be thinking about the life your adventurer might *want* to have. Keep it as a background goal, as the world and the gamemaster somehow manage keep your desired peaceful and normal life from ever actually happening...





*We believe that Terrans are genetically pre-disposed to certain behavioral patterns. This is not revelatory, it is the norm for all species we have yet encountered. What is unusual but ultimately unprovable is the idea that vast groups of humans had different genetic predispositions, some so incompatible as to place these groups at constant odds with one another. Without the arrival of the Aeth, they likely would have destroyed themselves within a few generations. So, in hindsight, the destruction of Terra and the forced genetic mixing among the Aethos survivors may have been the best thing to ever happen to this unruly species.*

*- intercepted communication, source unknown*

## INTRODUCTION

As a setting, **Aethos** is meant to be large enough for as much exploring and hidden or undiscovered stuff as you want. It has twenty-five times the surface area of Old Earth, proportionately more of that is land than on Old Earth, and the total population of sentient beings is less than that of Old Earth. So, add up all these things and the world of Aethos is much closer to the Victorian Era than the 21st century in terms of how much people know about it, and the speed and difficulty of getting to certain spots. A trip to Aethos' north or south pole would be closer to a voyage circa 1900CE than 2000CE in terms of difficulty, danger and expense, even if high-tech equipment is used.



So, the alien races that follow are for the most part, humanity's neighbors in this polygon. There is enough room in the setting for dozens of others of the gamemaster's design, some of which humanity might not have even heard about, or given our relatively short thousand-year history here, heard rumors about and have fragmentary, contradictory information on. Which from the standpoint of being a gamemaster, is the *best* kind of information to give to the players...

## Overall

The atmosphere and gravity of Aethos is suitable for human habitation. Temperature over at least half of the surface is compatible with a modern human civilization. So, virtually all the aliens that humans will meet are also going to be suited for a human-normal environment. The more or less constant climate at any given latitude means that aliens with a different preferred temperature have their own niche, but by and large everyone breathes oxygen and has a water-dependent metabolic system.

It would be interesting if all aliens on Aethos had compatible DNA with humanity, and it might answer a lot of questions about the Aeth, but this is *not* the case. There are *just* enough similarities in genetics to make a case for life developing from some ancient seeding of space spores or some other building blocks of life, but evolution has diverged things to where only traces of common genetics remain between the races. This means that outside of a race's home territory, there will often be competing or overlapping ecosystems. Terran and alien plants will try to colonize the same patch of land, Terran and alien creatures might desire to dig burrows in the same place, and so on. Some of the time, these plants or animals can benefit from the presence of alien life. A predator might find an alien prey to be something it can digest, but just as often, an alien life form is either of no nutritive value or outright poisonous. So you might find a fearsome alien predator wisely ignoring a slow Terran creature like a cow...or human.





Travellers who want to sample local flora and fauna either need to have a guidebook of safe cuisine, or eat very small samples and wait to see if there is any untoward reaction. Some things might taste awful but be edible, or taste fine but be hallucinogenic, toxic or both.

There are the alien equivalent of pest species in just about every inhabited region of Aethos. Plants that no local species wants to eat, animals with no natural predators and so on. The only real way to deal with these is to import what does *eat* them, to make the minimal adjustments to the ecosystem that keeps things in check. Over the course of the past 935 years, a degree of stasis has been reached between Terran species invading other regions and alien species invading Earth. *Solutions vary.* Kricakian borer beetles ruin unprotected Terran wood structures, but can be thwarted by preservatives that bond a selenium compound to the cellulose in the wood. Terran kudzu vines thrive in parts of Drinn territory, but a Cartoo sap-sucking moth carries a Tuae fungus that eventually kills the kudzu, so while it is not eradicated, it is kept from growing out of control.

Culturally, any genuinely alien race views other races with some vague unease, because by just about every standard of what is 'normal', aliens are...*alien*. They do not think like us (and vice versa), their government, social systems and beliefs are often markedly different, and their aesthetics come from billions of years of *different* evolutionary pressures. The things that alien races share in terms of culture are those things that are common in terms of biology and evolution. Successful species have some instinct towards self-preservation and reproduction. You can argue that most will try to expand to fill available environmental niches. These three things in a sentient species spur technological development, laws and traditions regarding mating and gender roles, desires to explore, conquer, and spread ideologies.

Entertainment, art and even architecture are influenced by our most primitive instincts. Humans might call a garage a 'man cave', advertising is laced with sexual imagery, and dancing, whether waltz or tango, is really just a pre-mating courtship ritual. Alien races will have their equivalents of all of these, and even if humans cannot appreciate them, we can understand that this is what they are, the importance to that alien race, and if we are being diplomatic, take it into account.

! It is worth mentioning that some humans will have a *literal* -philia or fetish about one or more alien races, and some of them will have them about us. Among humans, knowing this about a person will cause about the same degree of emotional discomfort as homosexuality causes for some people in the early 21st century. Some just take a 'consenting beings' approach, while others will consider it an affront to all that is good and holy. As far as adventurers are concerned, it is something that *is* known about, but which is not generally seen in public except in certain enclaves in certain cities where a more libertine opinion of sexuality is the norm (and of course, specific searches of online pornography, though results for *some* searches cannot be unseen). The closest there is to a mainstream acceptance of this is the existence of Cartoo dominatrices, who have existed in human culture long enough to become a cliché, but still remain far from the public spotlight. This aspect of cross-species conduct is odd enough and possibly disturbing enough to some adventurers (or players) to be good adventure background. Nothing makes an *adventurer* act with genuine discomfort more than a situation that the *player* is genuinely uncomfortable with...



### Quick human overview

Humans, mentioned again only because how humanity's neighbors view us is just as important as how we view them. The Cartoo are the closest to humans biologically, and maybe even culturally. However, they have no interest in our culture except to the extent that knowing it helps them in their goal of manipulating and ultimately conquering us. They view us as they view *everyone*, someone to be subjugated, someone to be subservient to or an equal that one must strive to be superior to so that you can subjugate them. That is just the way *their* minds and culture works, it is nothing personal towards humans.

The Drinn are culturally more homogenous than humans and do not understand our diversity of beliefs, in particular the willingness to do violence based on apparently minor differences in belief. They think it illogical that humans do not have larger families, the better to cull out the obviously unfit and encourage the remainder to strive harder, and they feel this coddling of *all* a mated couple's offspring is part of humanity's problems. They can intellectually categorize human foibles, but do not have an equivalent set of emotional responses to genuinely *understand* them.

The Tuaqq have been a 'net-connected' species for far longer than humanity, and consider our system of elections every several years to be hopelessly quaint and unsuitable. They are as vulnerable to demagoguery as humans, but have had a lot longer to compensate for it in how they have adopted mass communication techniques. There is no cult of personality around their elected leaders, mostly because they change them so often. Their sense of 'party identity' in terms of politics is almost non-existent, and while they can understand in an academic sense why it works for humans, they cannot comprehend it at the 'sense of belonging to a group' level.

They understand the problems that humans have in regard to charismatic but ultimately destructive leaders, but they are immune to any human attempts to manipulate them in the same way that humans manipulate themselves, and are quite adept at frustrating manipulative human media personalities when they are interviewed for any reason. Culturally speaking, they view us as children with guns, possibly as dangerous to ourselves as to anyone else, but not possessing a depth of culture or ideology that is useful to explore or adopt.

The Ancients view humanity as they do all other species, with a refined sense of cultural superiority that borders on snootiness. They are interested in learning new things about us, but not really interested in viewing these things on their merits, since the Ancients have a system that clearly works for them and have no need to adopt primitive versions of ideologies they abandoned millennia ago. Their interest in human culture is purely academic speculation.

! Names and alien-specific terms are both a matter of game flavor and a human interpretation of alien phonemes or concepts. Aliens understand that we are referring to them or one of their concepts, and generally do not take offense if we as a culture get it wrong, so long as it is not inherently offensive. Humans are probably less adept at realizing this than most aliens. It is a constant source of diplomatic irritation that the official subtext of all Cartoo government communications uses a linguistic form for Terran that implies 'soon to be subjugated'. But, that is just the way they refer to everyone who is not Cartoo and has not already been subjugated. To the Cartoo, we have simply not yet found our proper place in the scheme of things, which just happens to be subservient to the Cartoo.



## DRINN

The Drinn are vaguely insectoid or crablike, with pentagonal body symmetry, four legs that can also serve as arms, and one powerful leg that cannot use tools, but has a large claw instead. Two eyes are set on each side of the powerful leg, one a fixed compound eye, and another on a short, retractable stalk. The compound eye is angled upwards, and it is thought it served some evolutionary purpose against overhead predators at some distant point in their evolutionary past, as it is especially sensitive to moving objects. Their skeletal structure is similar to chitin, and they have overlapping chitinous plates which are over time, shed and replaced. An adult Drinn is about two meters across and a meter high, but due to the high mass of musculature, they mass about 100 kilograms and are several times as strong as a human in terms of leverage and lifting capacity. They pay for this by being slow in terms of their movement and reaction speed. A Drinn walking pace is a very slow human walk, and a sprinting Drinn is no faster than a jogging human, and not a very fit one at that.

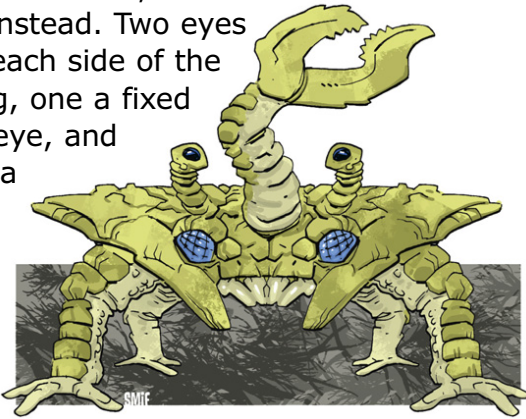

Drinn eat through a mouth that is below the strong leg, and breathe through slits spaced around their upper surface. They also speak through these slits, and hear through sensitive areas of skin over specialized segments of lung tissue. A Drinn voice is naturally stereophonic, emanating from all voice slits at once, but Drinn can vary this for a variety of vocal effects, language nuances and their equivalent of singing. For instance, speaking to someone with only the rear vent is considering insulting, the closest human equivalent being an implication that the person you are speaking to is only fit to be spoken to with your ass.

Drinn hearing range goes from a range below human hearing to about a human soprano. Drinn music is mostly vocal, with very little instrumentation (Drinn just aren't built for doing guitar riffs). Drinn aesthetic sense tends to match their natural environment. Floors are usually one of several ground colors, walls the color of stone or trees, and ceilings the color of sky or foliage. Their equipment and architecture matches their biology, with the biggest impediment to other races being that Drinn find a ceiling height of one-and-a-half meters to be just fine, and doors one meter high are pretty standard. Only facilities meant for commerce or diplomacy with other species will have doors and ceilings wastefully high.

The most notable feature of Drinn biology is that they have a high pressure circulatory system and no skeleton. Their muscles operate on hydraulic principles, with complex biological valves and leak-mitigation mechanisms. Drinn have several hearts that feed into a bony high pressure reservoir in the center of their bodies. Losing one or more hearts is not a fatal injury, but rupturing the pressure reservoir is like a heart shot on a human. Drinn are physically slow, but incredibly strong for their size. Their main claw has sufficient strength and hardness to cut through a human femur or crush a skull with ease.



These claws originally evolved as a defensive item and mating display, but the modern Drinn simply use them for the increased strength, sometimes crafting special attachments for them. The Drinn equivalent of a jack for changing a spare tire is simply a claw 'glove' that protects the chitin while the claw is used like a scissors jack. Similarly, the equivalent of a Drinn rescue squad simply puts giant scissor blades on a claw and uses it to cut vehicles open to get at trapped individuals. Some Drinn have made interesting adaptations based on seeing other races. For instance, there are the Drinn equivalent of stilts for the four lesser legs, giving them the ability to run faster (but with little Agility), and Drinn 'bicycles', off-looking contraptions powered by their one strong leg.

Unmated Drinn are gender-mutable. By some combination of social cues and chemical signals, a mating pair gradually go from sexless to male and female, a process that takes several months to complete. Drinn young start as a cache of fertilized eggs, which the parents sort through and select some number of, disposing of the rest. The lucky one are further gestated in pouches under scales on the back until they reach birthing age, at which point they are self-mobile, but like the young of other surface races, require many years of socialization, care and education to become self-sufficient adults.

Drinn generally only have one clutch of children in their entire life, so mating choices are made with great care, and the Drinn social, government and legal system places inordinate importance on the privileges, rights and duties of parents, as well as draconian punishments for those who would threaten a Drinn's bloodline. The closest parallel would be primitive human codes placing inordinate value on female virginity, or giving crimes of a sexual nature greater punishment than those involving killing.

The Drinn view criminality in terms of how it affects societal fitness, and the government takes the role of a parent who is quite willing to cull children who are unsuitable. This is not to say that they have the death penalty for *everything*, but they have no qualms about it and there are no vocal Drinn minorities who oppose it.

Drinn share most notions of what is 'criminal' with Terrans. Murder, theft, etc. The Drinn do have a legal and cultural notion that as long as you are doing no harm, your action is usually *legal*, though it might be *rude* and socially stigmatized as a result. So, walking across someone's property might be trespass to a human, but to a Drinn it is merely a shortcut.

The legal system on an adversarial model between the victim and the accused, each of which must be represented by a third party (serving the same role as a human lawyer). An interesting exception in many cases is that if the accuser (even the government) finds no one who wants to take the case, the case is automatically dismissed, and if the defendant cannot find anyone to represent them, they are automatically found guilty.

Drinn do not have fancy behavioral modifying tech like Terrans, so penalties are fairly simple: money, forced labor or death. Money is in the form of reparations for any damage caused, with a multiple based on certain crimes or repeat offenses. Labor is simply money paid over time and under confinement. If your expected remaining lifespan is long enough to pay the legal reparations through work, then if you lack the immediate cash, you are sent to a work camp. There are mobile work camps doing infrastructure repairs in Drinn territory all the time. You are released when the debt is paid, and it can be paid by anyone. If the legal penalty is too big for you to ever repay, you are simply executed. Normally there is a ten day period in which your legal representative can try to scrounge up enough money to keep you alive, but there are no other appeals.



Drinn are hydraulic creatures and tend to think in terms of fluids and flows. This works its way into their technology. They are comfortable at a Late Industrial Era technology and while a minority may own or embrace higher tech items, for the most part they have stagnated. Their material science and agricultural tech is further advanced, but they have no need or desire for computers. At the time of their own particular arrival on Aethos, they had been at this level of technology for over a thousand years. They had a space program, and had explored nearby bodies in their solar system, but all the technology in their space program was analog, not digital in nature.

The Drinn have a quasi-religion. They do not believe in a god or gods, but do believe it is *possible* for such beings to exist, and even for such beings to have brought about the Big Bang or some other means of creating the universe as we know it. Drinn who choose to speculate on such things tend to be scientists, who seek to find the 'clawmarks of god' on creation. Among humans, this would be someone trying to find a hidden message in *pi* or seeking to understand god through particle physics. Among the Drinn, this is not a religion with churches and scripture, just an underlying belief that the universe is *not* random and that someday it may be possible to determine the nature of that non-randomness.

Drinn have a decentralized government, operating mostly at a county level. Society is homogeneous enough that there are no major moral points of contention. Every few years or whenever it seems necessary, each district sends a representative to a meeting spot to discuss matters of import or pass information along to other representatives, and if a decision needs to be made, it is discussed and voted on, and that is the end of it. Drinn are remarkably consistent in their beliefs about what is best for the Drinn, both in the short- and long-term, and opposing viewpoints are usually on matters of *how* something should be done, not whether it *should* be done.

For their military, they have the equivalent of the best WWII technology, with a few tweaks and exceptions. Well aware of the capabilities of some other races, they are not shy about adopting technological concepts well past the Industrial Era. Drinn fighter planes are piston-engined, subsonic craft. However, they are made entirely of materials that give minimal reflection (often their equivalent of wood), with ceramic engines, ducted fans, heat and sound baffles, color-changing paint and very high velocity cannon shielded with the best radar absorbing materials they can make. Virtually no advanced sensors can pick them up and their weapons cannot be jammed, so while they are highly outclassed in a technological sense, they are remarkably hard to shoot down with anything except direct fire weapons manned by sentient operators. Heat-seeking, radar-guided or emissions-homing weapons are next to useless against Drinn fighters. Their reflexes do *not* let them be ace pilots, but they can handle very high g-forces and are not to be underestimated.

**Game notes:** Drinn are at +6 overall Strength compared to humans, but -3 on Agility, with a racial maximum of 8. They have a Weakness on Health with regard to running. Drinn cannot buy Running skill, use thrown weapons or engage in unarmed or melee combat except for wrestling. However, they get +2 Accuracy on any ranged weapon they can use, as their hydraulic muscles and stalked eyes let them aim with extreme steadiness and precision. The maximum Accuracy they can use is not limited by their Agility in most cases. A Drinn using its strong leg gets +3 Strength and -3 to Agility *over* the normal numbers, and it can do half-lethal crushing damage with that leg if it grabs something. For a normal Drinn, this would be a 5d+0 half-lethal attack. Blades could be attached to this claw to made the damage lethal instead. Drinn have an inherent 2d+0 armor against low-tech attacks (blades, arrows), and while *any* lethal hits done to their pressure reservoir (+6 difficulty called shot) will result in death, this location has a total effective armor of 3d+2.

Drinn infantry are slow but quite strong, and can wear armor and carry conventional weapons that other races could not manage without powered exoskeletons. The *standard* Drinn infantry rifle is the equivalent of a .50 caliber semi-auto sniper rifle, and the Drinn equivalent of a squad has at least one *heavy* weapon, often a high velocity rocket launcher and a few types of rockets. Each Drinn infantry is its own little rocket-equipped APC. The Drinn use mechanized transport only for moving from place to place, not as units of battle. The Drinn road network is extensive enough that the Drinn can effectively use 'bicycle infantry', and their road network is also part of their defenses, as all their bridges and overpasses only have a clearance of two-and-a-half meters. Drinn gear and weapons is usable by Terrans, but with a -2d penalty.

A distributed command structure and countless arms caches mean that any invader would have to deal with an instant, well-equipped insurgency. *Think of them as Swiss starfish.* The Cartoo have made hostile overtures towards the Drinn in the past, thinking that the Drinn military was a purely defensive one. The Drinn responded by building several thousand stealth bombers and flattening a Cartoo city, just to make the point that their military is defensive as a matter of policy, *not* passivity. The bombers disappeared faster than they were built, and no one is sure if they were scrapped, taken apart or just stored away someplace secret. The Cartoo as a race have not tried anything like that since. Some individual Cartoo collectives have undertaken plots against the Drinn, but by and large the Drinn have little the Cartoo want except the possible satisfaction of subjugating them. However, the Cartoo prefer to make a profit out of the affair, lest they weaken themselves and become vulnerable to other Cartoo. The Drinn have no tech the Cartoo want, and Drinn territory is not the friendliest biology to transplant Cartoo settlers into, so the Drinn are for the moment, fairly safe from Cartoo machinations.

## CARTOO

The Cartoo are the bad guys of this polygon, with humanity coming in a fairly strong second place (our attitudes are often excused because we are 'new' here and just do not know any better). The Cartoo are the ones who had an invasion plan in place just waiting for the Aeth to drop a shell-shocked civilization and resource-rich ecosystem next to them, and only reluctantly sought peace after some unexpected Aeth tech turned several hundred humans into unstoppable killing machines, suicide drones and überninja infiltrators. And the Cartoo did this within their own polygon, which is a fairly strong taboo among the surface races (do not foul your own nest). In the decades the first Earth-Cartoo war lasted, humanity was able to get its own industry sputtering along, and had a fair amount of covert assistance from the Drinn and Tuaqq, both of which are powerful enough that the Cartoo cannot bully them, but not so powerful that they can openly offend them.



The important thing to remember when discussing the Cartoo is that you can talk about individual Cartoo, or groups of Cartoo, but not a Cartoo 'nation'. Their personalities allow them to do *some* things at a species-wide or national level, but foreign policy and military operations are not among them. The closest parallel would be to think of them as profit-oriented mob bosses. We will get into more detail later on, but keep that in mind for now.



The vast majority of Cartoo are opportunistic, paranoid xenophobes. This is not a deliberate function of their culture. Rather, like other races, their culture is a byproduct of their neural wiring. Cartoo have many 'human' characteristics, just to an exaggerated level. To a Cartoo, everything in the world falls into one of three categories: *Should I chase it, should I run from it, or should I mate with it?* Fortunately the latter is limited to other Cartoo.

If you appear weak, it is in their nature to subdue you. If you appear strong, it is in their nature to withdraw. Nothing frustrates the Cartoo more than being in an intermediate state between the two, and agreements made in one state are really only valid to a Cartoo as long as that state exists. If a subdued Cartoo gets the upper hand on you, all agreements made in the subdued state are null and void. Humans might consider this dishonorable. *Cartoo simply assume it as a given.*

The Cartoo are why humanity, against the advice of the Drinn and Tuaqq, tried to develop nuclear weapons, simply as a protective measure. It has been long suspected but never proven that the Cartoo deliberately goaded humanity onto that self-destructive path just to create an opening to attack Earth again. Whether or not that is the case, the second Earth-Cartoo War began right after the Aeth evaporated Earth's nuclear program, along with the city that housed it and its two million inhabitants. *Just as if the Cartoo expected this to happen and were ready to capitalize on it...*

The last Earth-Cartoo War (the fifth one) was about two centuries ago. Since then, Earth has been (or appeared) strong enough to keep Cartoo ambitions pointed in other directions, though border skirmishes and probes still happen every few years.

Earth and Cartoo have nothing that can be considered formal diplomatic relations. However, Cartoo channel their instincts into more than simply conquering or retreating. Many of them are *extremely* savvy business types. There are trading towns on either side of the Earth-Cartoo border, where each side can engage in not-quite-literal cutthroat competition in the open marketplace. On the Earth side, things are governed by Earth law and it is fairly safe. On the Cartoo side, business runs by Cartoo rules, and safety exists only because it protects trade. Cartoo cannot make a profit off Terrans if Terrans get scared off and do not come back. This is a very relative safety, and operates under a complex set of Cartoo social moires. For instance, if you come to a Cartoo trade town on your own, you are on your own, and your relative strength is the main thing that keeps you safe. If you come at the invitation of a Cartoo trade concern, then you are under the shelter of their relative strength while you are there, but this makes you the inherently weaker party as far as that trade concern goes, so your ability to negotiate a good deal is hindered.

Both Earth and Cartoo are extraordinarily thorough about searching trade contingents and making sure that any aliens entering their territory eventually leave their territory, one way or another. If a Terran disappears from a trade delegation in a Cartoo town, the Cartoo will turn the place upside down to find them, not because they care about the Terran, but because they do not want a possible spy loose in their territory. They do not care if they find the Terran dead or alive, they just want to be able to account for the body. Earth and Cartoo traders are allowed a limited set of weapons for self-defense. Nothing exceptionally powerful nor current military tech, but sufficient for personal protection and causing a ruckus. The Terran equivalent of 'legal weapons' and armor are about right.



This tends to make humans more vulnerable in Cartoo areas and Cartoo more vulnerable in human areas, and the complex web of quasi-diplomacy that makes any sort of peaceful trade possible is not for the easily confused or squeamish.

**!** Adventurers would not under any circumstances want to try to engage in trade or do any other business on the Cartoo side of the border unless they had someone with at least a 4d+1 skill roll in Law *and* a +1d specialization in 'Cartoo trade'. Having such a roll implies that you have done this sort of thing several times, learning under a master trader, and this should be part of the adventurer's background history.

The Cartoo are an upright bipedal-bimanual species with a triangular limb symmetry and bodies that are somewhat flattened towards their front (similar to humans). Articulated in about the same way as humans, their ankles split into three large independent toes, and their wrists split into three heavy fingers, each of which has three smaller digits for manipulating objects. Their feet used to be like their hands, but the sub-digits fused into the current large digits at some point in their evolution. It is presumed they were a semi-arboreal species in the distant past. Cartoo vision is based on four eyes, two larger ones with excellent depth perception but only moderate resolution, and two smaller ones with only short-range focus, but exceptional clarity. Effectively, they are nearsighted for everything except gauging distances. This means that long-range Cartoo weaponry requires optical enhancements for a Cartoo to see and draw a bead on a person-sized object at ranges past about a hundred meters. The early Cartoo history involving firearms tended to rely on scatterguns and other short range devices, and it was not until they invented optics that they had any need for rifles or longer range aimed weapons. This is, despite its antiquity, still somewhat ingrained the Cartoo psyche. Or perhaps it is just genetic.

Cartoo have no problem with long range weapons, but they *prefer* to see what they are fighting directly, rather than through devices, thus they often end up in short-range combat. Because of anatomy differences, Terrans would use Cartoo weapons and most other devices at either a -1d penalty or need +3 time to do the same thing equally well.

Cartoo senses are analogous to human senses, with slight differences in the nature of their perception. They hear, see, taste and smell not quite in the same ways and ranges as humans, but there is quite a lot of overlap. Cartoo communication is vocal, and can be understood and replicated by humans, and vice versa. However, anatomical differences make it unlikely one race could vocally impersonate the other. Note that electronics is advanced enough to modify a race's voice sufficient to mimic it for radio transmissions, provided the speaker makes no gaffes in syntax or common usage of the alien language.

Cartoo reproduction is analogous to human reproduction, a male-female differentiation of the sexes, a small number of offspring per birth and an extended period of physical immaturity. Unlike the Drinn, the Cartoo place a great deal of value on all their children, but this wanes as they approach maturity. Once a Cartoo begins to assert itself or interact with the adult world, the ties of family are merely a way for the parent (or child) to extend their personal influence, rather than an overriding affection like love. Cartoo males are only slightly larger than females. Male involvement in child-rearing is higher than humans, so Cartoo pair-bonding is an important part of their culture, and male and female Cartoo are viewed equally in terms of social status. For those interested, there is no mechanical compatibility between humans and Cartoo, but a few Cartoo females have found employment among Terrans as dominatrixes, a profession their psychology makes them admirably suited for.





Cartoo lifespan is shorter than Terran lifespans, but only because they do not consider it worthwhile to prolong the life of the weak with expensive treatments and therapies. Their science is quite capable of pushing their lifespan up to the hundred-plus year average of Terrans, they simply choose not to. The Cartoo are adept at cybernetic replacement of lost or damaged body parts, and while their biological sciences are capable of some regeneration therapies, they prefer if possible to replace damaged natural parts with stronger or more capable artificial ones. The fact that the Cartoo do this is one reason humans tend *not* to, a 'we don't want to be like them' sort of reaction.

In addition, humans abandoned most cyber-replacement parts once regeneration therapies became commonplace in the late 21st century (and rationing of technology for the doomed Old Earth war effort against the Aeth meant that biological replacement was cheaper and more available).

Cartoo government is about what you would expect from what you have learned of their personalities. The closest human equivalent would be organized crime. It is a hierarchical structure of money and force and shifting loyalties, one that holds together for years or generations, then is chaotically and sometimes violently overturned and replaced with the same thing, just with new people in charge. The Cartoo have an oligarchic council of 'mob bosses' that makes decisions for the Cartoo as a whole and enforces its will on its members. The individual oligarches have, within the limits imposed by the council, full autonomy within their own region. These are broken down into smaller regions with lesser bosses and so on, serving many of the same functions as conventional government. Things are run for the profit of the oligarchs, and the happiness of their 'constituents' matters only to the extent that it keeps the oligarchs from being assassinated and is good for profits.

In addition to the geographical division of power, the Cartoo council also oversees an organizational division of power. Individual oligarchs have their own private armies, but there is also an overall Cartoo military (smaller than any individual oligarch, however), a central technology research agency, espionage agency and even an industrial standards agency (everyone's electric grid is the same, etc.). These individual agencies are run as their own little fiefdoms, but have no territory, only resources. These agencies are answerable only to the council as a whole and tend to be the spine of Cartoo planning continuity.

So, interactions between any race and the Cartoo are almost always between some low- or medium-level Cartoo lieutenant, whose authority to act is either limited by the dictates of his boss, or who is bending the rules to make deals to help him (or her) take over a higher spot in the Cartoo hierarchy. Cartoo businessmen, and for that matter, all Cartoo are part of this hierarchy. Everyone is above someone and tells them what to do and expects a piece of the action below them, or is below someone and is trying to hide their actions so they can keep a bigger cut. There is a complex and ever-changing web of carrots and sticks to keep the system working, and the Cartoo are born into it as part of their culture. Only the savviest human negotiators can work the system to their advantage.

Cartoo society is about what you would expect given the previous description. Sibling rivalry is high, and while there are not nearly as many bloodbaths to determine the heir as in Cartoo ancient history, it is only because the modern bloodletting is more symbolic, often leaving the losers with little rank or currency to their names. A Cartoo fable called 'The Tale of the Twins' is considered a must-read for high-ranking Terran politicians and business leaders who might have to deal with the Cartoo. To Terrans, it is a reminder of what Cartoo are willing to do to get ahead. To Cartoo, it is a tale to educate their *children*.



To give you an illustration, the first Earth-Cartoo War went something like this:

For the past several Arrivals, the Cartoo began to negotiate with each other several decades in advance. This would be along the lines of "If you promise not to attack me while much of my force is elsewhere, I'll go elsewhere and not attack you when your forces are also elsewhere." Being Cartoo, each party would know the other would break this agreement if it was profitable to do so, so each of them would also make mutual defense pacts (or mutual backstabbing pacts) with other Cartoo groups. And since all the Cartoo knew that all the other Cartoo were doing the exact same thing, the only thing that really mattered in the end was up-front payments and the fine print. The end result is that the average Cartoo 'state' had the equivalent of several divisions of armor and infantry, plus air and sea power to devote to external aggression. For every Arrival except the previous one, it ended up being a bust. The closest they came was at the Tuaqq arrival about two millennia ago, but the Drinn surfaced several hundred missile-equipped subs in the middle of the central sea for live-fire maneuvers just about the time the Cartoo airlift started. Apologies were rendered for the numerous Cartoo cargolifters and fighter planes 'accidentally' shot down while headed to Tuaqq territory, but no reparations were ever made, despite numerous demands.

Anyhow, when Earth was transplanted next to them, they were ready to go. The idea was that if Earth was low-tech, they would simply take the territory from the primitive defenders, and then exploit their resources and use them as subservient labor. If Earth was high-tech, then Earth would have already mined and concentrated valuable elements, and the Cartoo would swoop in during the chaos, take the territory if possible, and if not, just loot it of the most portable, valuable commodities, at least until the cost of the invasion at been paid for.

Some of the smaller Cartoo concerns were simply mercenaries for larger ones, and many of these groups turned a profit on the war against Earth. Most of the larger ones did not, and at least one underwent a 'change of management' as a result.

The other Earth-Cartoo wars have been much the same. The second one still had *some* aims of taking and keeping territory, but the rest have been about either profit or manipulating other Cartoo into a bad domestic situation so that profit could be made off of the other Cartoo's misfortune. There is an empty patch of scarth between the Cartoo and the Drinn, and no doubt the negotiations are beginning to invade any territory that might be placed there in the current Arrival. This time the Drinn will be taken into account, as well as the Tuaqq and of course, the Terrans. Exactly how the Cartoo intend to manipulate the situation is unknown yet, but the Cartoo *do* know that Terrans are remarkably easy to goad into irrational courses of action. The Cartoo are secret partners in any number of Terran businesses (often through other aliens), they deploy troops just to measure Terran reaction, they eavesdrop on communication, try to blackmail or extort, and generally do all the sort of things you would expect humans to do, except it comes more naturally to them than to us.



The Cartoo legal system is an extension of their culture. They dislike equal outcomes, so a legal situation has a winner and a loser. This usually means that the loser ends up paying a price to the winner in addition to any penalty they suffer for themselves. Penalties can be financial, social, corporal or freedom-depriving, depending on the crime, who committed it and who was the victim. *An failed prosecutor might have to pay a fine to a person who just got acquitted. You might end up doing hard labor under the supervision of the person you committed the crime against!*

From a Cartoo point of view, the biggest crime is *getting caught*, for that by itself is a measure of your competence (or lack of it). So, simply being apprehended (or successfully framed) is already a strike against you.

A Cartoo defendant has two choices for a trial, a judge who is of a higher social rank and in your same organization (or immediate social, political or financial grouping), or a jury who is of a lower social rank in that same group. The judge can be anyone who accepts the defendant's request, as the Cartoo have no dedicated judiciary. Given Cartoo society, this means you will either be judged by someone who knows you might have been plotting to take their place, or have a jury of people who you stepped on to get to your current position.

*Not surprisingly, the conviction rate in Cartoo courts is remarkably high.*

There are a few exceptions and caveats for cases where the normal judge, jury or crime rules do not strictly apply (like for outsiders), and there are also occasionally invoked ancient statutes for blood feuds, duels and matters of paternity. For Terrans ('those who have not yet been subdued') caught on the wrong side of the Cartoo law, it is simple: *You are guilty as charged. The only thing to be decided is if you have sufficient funds or influence to pay off the person who will pass sentence on you.*

Cartoo technology is roughly the same as Terran. Both cultures have reached most of the pre-atomic limits imposed by the Aeth. Cartoo are more advanced in their electronics, especially bio-electronic interfaces like cybernetics, while Terran medical and genetic advancements are superior to Cartoo efforts. Culturally speaking, the Cartoo have avoided *all* autonomous robotics. They had a nasty internal dust-up before humanity arrived, when assassin-bots were all the rage. After the bloody end of that internal dispute, all Cartoo devices with any degree of mobility have to be controlled by a biological sentience.

So, unlike humans, there are no self-driving cars, no hands-off autopilots for planes, no fire-and-forget missiles. If a Cartoo wants to kill someone, someone has to be behind the intent from start to finish. One thing humanity has found out is that the Cartoo have *zero* tolerance for anyone they can identify as having used that technology against them. A Terran fighter pilot shot down after using a homing missile on a Cartoo plane would be summarily executed if caught by the Cartoo. They do not even hide it behind euphemisms like 'shot while trying to evade capture'. It is just 'he was using a weapon we do not like, so we executed him as an example to others of your kind.'

The effects of this on Terran military planning vary from generation to generation, but at the moment most advanced Terran hardware relies on smart aiming or active guidance, though there *are* plenty of fire-and-forget munitions available should the need arise.

**Game notes:** Cartoo have the same range of Attributes as humans. They have a Weakness on sight perception that is easily corrected with technology (laser-blocking glasses that also correct near-sightedness are standard for Cartoo soldiers). Their range on the Age trait is the same as in the basic **EABA** rules. Their personality notes as previously described are not really a trait, they are simply what a Cartoo is, just as strong as a human's instinct towards self-preservation. *It is what they are.* A player running a Cartoo would have 'family' and 'associates'. *There is no Cartoo word for 'friend'.* The word for 'equal' translates as 'someone whose power does not encompass me but whose power I still respect'. *Basically, someone too big for me to take on, but not big enough to take me on.*

A Cartoo will not always be *actively* scheming against those above them, but they *are* always at an instinctive level measuring the flow of power around them. This makes them quicker to spot opportunities or vulnerabilities than most humans, more likely to take advantage of opportunities or at least investigate whether an opportunity is worth pursuing.

The only difference between 'family' and 'associate' among the Cartoo is that it is considered a failing of dominance on your part if you have to assassinate members of your own family. This attitude would make it hard for a player-controlled Cartoo to create any kind of lasting relationships with the other adventurers. Either a Cartoo *will* want to usurp leadership of the group, or a leading Cartoo will always be worried about the other adventurers trying to usurp them.

## TUAQQ

In terms of biology, the Tuaqq share a bit with Terran reptiles. They have a very limited ability to regulate their body temperature. Unlike Terran reptiles, they can compensate for this chemically rather than energetically, using hormones, enzymes and blood thickeners and thinners stored in special glands to allow them to operate in temperature ranges that humans require cold weather gear or heat precautions for. This means that in game terms, some of their stats will vary slightly with temperature. Tuaqq skin is more cut and abrasion resistant than human skin, but not so much that it is a significant armor (0d+1 vs. cuts and abrasions). They are naturally as tough as a pair of thick denims, and as a result can play a bit rougher than humans are used to.



! Make a claw with your hand and ignore the middle finger. That is about the spacing of Tuaqq digits.



Unlike humans, Tuaqq are evenly muscled in their arms and legs. While toes and claw tips can be sharpened, Tuaqq social custom dictates dulled claw tips for anything except soldiers. There are ingrained evolutionary connotations to sharp claws among the Tuaqq, and it is considered a great social *faux pas* to display sharp claws if you are not in a killing mood (or profession). This translates into display of open blades by other surface races. *So, a human having a Tuaqq over for dinner should leave the steak knives in the cutlery drawer...*

Most Tuaqq tools have ball-shaped handles for ease of use with their claws, and their technology is designed with their talon arrangement as well. Tuaqq can use their clawtips like humans use fingertips, but this has no tactile sensitivity, whereas the Tuaqq plam is quite sensitive, and can be used with tactile output devices. For instance, diagnostic or low energy alerts for Tuaqq weapons are transmitted by tactile emitters in the weapon grip.

Humans can use unmodified Tuaqq equipment, but only with some awkwardness (an extra -1d penalty). The Tuaqq hear through neck membranes and have eyes on the side of their head, which combine for binocular vision to the front, but allow direct sight in arcs where humans only have peripheral vision. Their range of color perception is not as sharp as humans, but they have measureably better night vision, leading to the belief that their special temperature regulation mechanisms were necessary for a role as nocturnal hunters. Tuaqq are omnivores, but have a preference for meat.

Tuaqq females are the dominant gender, and physically larger. They are also a notable minority of the population, so selection for male fitness is a major factor in mate selection. Males are just as intelligent as females, but more numerous and thus less valuable. Only the upper percentage of any generation of males will ever have *any* breeding opportunities. Because of the selection pressure on males, it is not uncommon for a group of brothers to work together to enhance the success chances of their most talented member, so that their genetic line is maintained. *As long as someone in the family is successful, everyone else is expendable.*

Tuaqq have live birth of several young at once, and as mated pair will usually only have one brood as a matter of law. The Tuaqq are well aware of the limits of their environment and that technology has allowed them to have a reproduction rate that would easily overwhelm the resources of their territory. They *do* have colonies outside this polygon, but they are not an expansionist species. The infants are well developed at birth, about the same as a two- or three-year old human, but their mental capacity is closer to a self-sufficient Terran reptile.

Tuaqq young grow from instinctive animal survivors into sentience in about three years, and from that point they are given their names and progress much the way humans do. Childhood mortality is high for an advanced technological species, but this is mostly among the males, and is usually because of accidents. Culturally, Tuaqq accept and expect not all of their male children to survive to adulthood. Tuaqq infants are naturally curious and explorative, and in their pre-sentient stage they are given quite enough freedom to get themselves into trouble. Falls from heights, perils of electricity and machinery, and in rural areas, even natural predators take their toll, leaving only those with better luck or more intelligence to reach adulthood.



Tuaqq have been on Aethos for about two thousand years, having been transplanted here one Aeth system visit before humanity. Their technological development is at the same level as Earth. Or more precisely, Earth technology is mostly derived from adapting Tuaqq technology similar to our pre-Exodus items and we have just managed to catch up with them a few centuries ago. There are minor differences across the various scientific fields. Human medicine is more advanced. The Tuaqq have not been able to duplicate human regeneration techniques. However, the Tuaqq are extremely adept at use of electronic networks. Their entire society is connected electronically, down to the most trivial electronic objects. This has a *huge* electronic overhead, which they tax and budget for and accept as the cost of their way of life, though it forces some austerity in other areas.

Their government and culture reflects this, being a full participatory democracy that is based mostly on meritocratic principles. If there is a crisis, they have no problem ousting their entire leadership in a special vote and replacing them with people who have the skills needed for *that* crisis, and just as quickly ousting *those* people when the crisis has passed. This makes diplomacy with humans quite interesting, since humans seek to form long-term relations with individuals or ideologies, whether internal or external, while the Tuaqq are happy with what works for them *right now*.

As mentioned earlier, they are somewhat vulnerable to demagoguery, but they are *also* trained from early sentience in how to use their information networks to quickly find the information they need to make an informed decision. It becomes very difficult for a rogue faction to push a hidden agenda when *everyone* can look at every bit of public information and connect the dots. It is a universal Tuaqq belief that someone who does not present a complete answer to a question is hiding something, and that someone who does not present known evidence against their own position has a weak and possibly fraudulent argument.

Again, you can compare this to the normal human politicking and see how things can get complicated. A Terran politician saying one thing to the Tuaqq in negotiations and something else to their constituents or the media can sink a negotiation. Fortunately, the Tuaqq realize that the Terran Legislaat is made of factions, not all of which agree with the executive and which do not speak for the government as a whole. The Tuaqq do not like wasting their time, and will often not even begin any sort of international negotiations with Terrans unless the Executive has sufficient votes and support in the Legislaat for the deal.

Because the Tuaqq are culturally wedded to constant interconnectivity and information access, their legal system relies heavily on this. A person's electronic trail is to some extent a valid alibi. While it may not pass full legal muster in court, it is usually enough to avoid immediate arrest if it indicates you were not at the scene of the crime. Criminal or civil cases are based heavily on information and information trails. Who knew what, when they knew it and who they knew it from. A Terran lawyer who relied on seeding doubt or denying the validity of information would be laughed out of court *after* being fined for wasting the court's time. *Information is either true or it is not*. Presenting either truth or falsehood as ambiguity is in many cases, a crime unto itself.



Additionally, any trial that does not involve matters of government security is open to the public over the Tuaqq information network. Any observer may petition the court if they have relevant evidence that they can back up. Trials have something like the Terran wedding invocation of 'speak now or forever hold your peace' before a final verdict is read.

Tuaqq legal sanctions tend to be financially and informationally punitive, with incarceration only for cases where the defendant seems unable or unwilling to comply with other punishments. Having one's network identity restricted is almost the same as physical imprisonment to a Tuaqq. The threat of being unable to vote, comment or speak one's mind in a public forum is a significant deterrent to most Tuaqq, like the threat of taking away the cell phone of a human teenager who has hundreds of texts or calls a day. Similarly, one's geographical freedom can be restricted by using your network access as a locational device. If you are only allowed to be at home, at work and have to do your grocery shopping at a particular store on a particular day and time, this is a noticeable constraint, but better than actual physical confinement and restricted information access.

Tuaqq are well aware that their culture and social stability is *utterly* dependent on their connectivity. Enough records of their past remain that they remember their own bloody civil wars on their ancestral planet, and the chaos of the first new Arrival a millennia after they arrived on Aethos, so their networks and devices are built as fault-tolerant as possible. They cannot do anything if the Aeth use some technology that destroys all electronics as it did during the human Exodus, but they have vast underground archives of hardcopy knowledge and each community has its own emergency plan putting certain people in charge of certain things in the event of a communication disaster.

The Tuaqq military has many similarities to Terran armed forces, separate branches for land, water and air-dominated operations. Unlike their government, being in the Tuaqq military is usually a lifetime career. Individual commanders for a given operation are determined by a complex voting mechanism, and this can include promotions and demotions to keep the overall chain of command stable. Demotion because someone else is better for your command for a particular operation is *not* a negative event for one's career. The Tuaqq equivalent of squads will frequently change lieutenants in the midst of combat and platoons their captains. Rank is a matter of pride and there is desire and incentive to excel, but a temporary demotion because someone else has a better skill set for a particular operation is expected, just as you would expect to lose a temporary promotion after such an operation. The difference is that if you do well in your promoted capacity, it looks good on your record, while a temporary demotion is almost always a neutral event.

Tuaqq military hardware is fairly complex and based on smart devices, fault-tolerant and jam-resistant mesh networks. Any given Tuaqq military formation tends to act like a single large organism, each part of it constantly aware of what other parts are doing and acting accordingly. The Tuaqq are *very* fond of laser weaponry. They are aware of its limitations and that other races know these limitations, but they use them as primary armament anyway because it makes their logistics a matter of energy, not physical ammunition. For secondary weaponry, they use smart weapons, things like variable ballistic grenade launchers, adaptive near-intelligent minefields, autonomous missile-equipped drones and the like. They are aware of what this might mean in a fight against the Cartoo (should there be one) and accept it as the price of war.



The Tuaqq are on the opposite side of Earth from the Cartoo (opposite side of the central sea in this polygon) and have not had any full-scale invasions by the Cartoo. While the Cartoo would have easily have been able to mount an invasion over a mere continent-sized chunk of unpopulated scarth prior to the human arrival on Aethos, they did not. *Neither side says why*. If you dig for information, the impression is that the Tuaqq were busy rebuilding and did not even know about the Cartoo for a generation, and the information you can glean from the Cartoo is that they were in the midst of an internal power struggle and by the time it was over, the Tuaqq were no longer an easy pushover. However, looking even deeper into either story shows some inconsistencies, and anyone making inquiries to that extent *is* going to be noticed. Even the Terran government will act to prevent its own people from digging into the matter past the *apparent* explanation. Whether this is because the actual truth is somehow a sensitive matter for the Terran government, or because the Tuaqq are our biggest trading partners is unknown.

**Game notes:** Tuaqq are +1 in Strength and -1 in Will compared to humans, and have a Forte in sight perception at night. In temperatures above 30°C, Tuaqq are +1 on Awareness and Health, and at temperatures below 10°C they are -1 on Awareness and Health, with further drops each 5°C less than this. They can offset this somewhat with insulating clothing, but their biological means of compensating for cold weather tends to make them more sluggish and the only way for a Tuaqq to avoid this for long exposure is electrically heated clothing.

Personality-wise, the average Tuaqq is almost like a text-obsessed human teenager. They will use portable devices to check in on the overall political situation, their hometown, and their friends and relatives many times a day, and will go through emotional withdrawal if they have to be in an area without good radio reception. Long-range Tuaqq expeditions may include radio relay aerostats, and internal expedition status often includes negotiation for bandwidth. Lower-ranking explorers or staff may use gigabytes of access like humans would use cash in a poker game.

When Tuaqq are connected, they are very up-to-date on important issues. But it does lead to some interesting interactions, like a Tuaqq pausing a real-world conversation to answer the phone, the other Tuaqq taking advantage of this to make a call of their own, then both of them wandering off, only to restart the conversation over the phone later on, possibly interrupting a real-world conversation to do so. For matters of great importance or priority, there are protocols to deal with this, so you do not have to worry about a bunch of generals making strategy losing focus because they are all answering texts from their adolescent children. But in casual situations, Terrans can find it *very* annoying.

Tuaqq are probably the easiest of the alien races for players to use as adventurers. The long and peaceful history with humanity, good trade relations and more-or-less compatible gear and foodstuffs means there are less problems than with the other races. And there is nothing in the Tuaqq mindset to prevent them from spending a long time away from home or forming emotional attachments to humans. A Tuaqq who is not welded to their need for constant information access and can still make sound decisions is a rarity and would make not just a good adventurer, but a resource that the Tuaqq hierarchy values in dealing with other races, despite how odd such an individual might seem to *other* Tuaqq.





## THE ANCIENTS

They are a very old surface race, having lived and survived on Aethos for over thirty thousand years. They are certainly the oldest *surviving* surface race. They are technologically stagnant and culturally introspective. They have achieved about everything that is possible within the non-nuclear limits the Aeth impose, and they value stability and order and reason. They are also emotionally cold to all non-Ancients. They will provide advice to other races, but will not lift a finger to save a race that gets itself into trouble. The Ancients are not in the same polygon as Earth, but are located over ten thousand kilometers slightly northwest of Earth's closest border, separated by mostly empty polygons that have a number of minor colonies of various races. The most direct route from Earth to Ancient territory passes over Cartoo territory, so any travel to the Ancients has to swing a bit wide, adding to the distance, and making Ancient territory virtually inaccessible during hostilities with the Cartoo. They are close enough to be accessible by long range conventional aircraft, but far enough away that it is inconvenient to meet them in person. There are no commercial flights, so any visit requires a chartered jet, which will probably cost about 500 Eur an hour, regardless of whether the jet is flying or sitting on a runway. Suborbital shuttles are available, but are very expensive and usually limited to the ultra-rich and the government. If the gamemaster wants interactions with the Ancients to be more common, they can be situated closer, within range of an extended land journey (possibly on the other side of the Belt, just to keep it interesting).



The Ancients have taken upon themselves a role similar to Earth's Arkivists. They have information on many of the surface races of Aethos, living and extinct, and they always seek more. Within their own culture, they are largely free from physical want, and they have sufficient defensive technology to make them not worth attacking. So, they need nothing from other races and take no sides.

As far as outsiders are concerned, knowledge is the *only* currency. The only thing they will give for free is advice, and they give the advice unasked. If you actually want *specific* advice from them, *you have to pay for it*. To get knowledge from them, you must give knowledge of equal or greater value. This makes them very irritating to deal with. *Ever tried to pay for a hotel bill with a Ph.D. dissertation or car repairs with football trivia?* Simply arranging for accomodation or refueling in Ancient territory requires that you have sufficient quanta of knowledge to pay for it, otherwise you are not even granted permission to enter their airspace.

The Ancients are, and are meant to be a plot device. You need to know something that only the Ancients know? *Then you have to give them some knowledge in return*. What kind of knowledge, you ask? *Why it just so happens that the Ancients are looking for something, and since they never leave their home polygon anymore, someone else will have to find it for them...* The Ancients are masters at subtle manipulation. They live longer than most and know more than most. So, they see where the pieces on the board are moving more clearly than most, and plan accordingly. While they have become stagnant as a culture, this does not mean they are merely waiting for their own extinction. No, they want very much to survive, and possibly even get some of their kind off Aethos. And they use information as their tool, offering it, selling it, seeking it, using it as a way to get other surface races to do what they want, without those races ever realizing the extent to which they are being used.



Physically speaking, the Ancients are tentacled mammals, with six short limbs of two different types (three strong mobility limbs and three weaker manipulator limbs), that are arranged symmetrically around an upright core. They have a skeleton, and their limbs each have a structure akin to a human spine, giving strength and flexibility. They have trinocular vision set in a elongated skull that has analogs to human features (nose, mouth, ears). Whatever their biology used to be, the Ancients now reproduce entirely through technological creches, and there is little visible difference between the at least two genders they have.

The lifespan of an Ancient is unknown (they do not sell knowledge of *their* biology), but it is longer than human lifespan and less than a millennium. Ancients have not been seen with any visible cybernetic enhancement, but they do usually wear advanced interface devices. It is presumed that their medical technology is as advanced or more so than humans, allowing nearly full regeneration and freedom from disease, cancer and most of the age-related degenerations. In addition to knowledge about themselves, the Ancients will not sell knowledge *they* deem of military use, nor any knowledge that a race could have possessed had that race followed Ancient advice. So for instance, the Ancients might have full knowledge of the Arabic language, but since Earth failed to take their advice and put knowledge and cultural heritage items in ships to transfer it intact to Aethos, the Ancients will *never* sell that knowledge to humanity or anyone else. It is their little bit of cultural spite. *You spurned our wisdom, therefore anything you might have saved by following it will be forever denied you. The lesson may be lost on you, but we will find value in it by using you as an example to others.*

Being a cautious race with long experience of races like humanity, the Ancients will take such knowledge, encrypt it, and then physically remove it from their systems and store it in a location not accessible to outsiders or outside information systems.

! You can make an alien race *really* alien, but that removes them from any sort of meaningful interaction with the adventurers. *The Aeth are a prime example. Otherwise, aliens will always to some extent be 'humans in funny suits'. SF authors may take offense at that, but stop and think about it. In order for a human reader (or rpg player) to understand an alien well enough to engage in meaningful dialogue or emotional interaction, the alien has to share enough qualities with the human to make this possible. Yes, there will be fundamental differences, but these can only be understood or overcome if there is also common ground. So, if you are making up your own alien races for Aethos, as you decide how they are inherently different than humans, also decide how they are inherently similar. However, figuring these things out is up to the players...*

## ARKIVISTS

The arkivists are a subgroup of not just humanity, but most of the surface races. These are people/beings who are obsessed for one reason or another with the details of the destroyed homeworlds of every race that has ever been transplanted to Aethos. Human Arkivists would all know Old English, for instance, and would know more about the true history of the Exodus than the great majority of the population. And can prove their version of history through carefully preserved Earth artifacts and records, which makes them no friends of either conservative Biblists or politicians wishing to ride on humanity's valiant struggle against the Aeth for their own purposes.



Arkivists are not necessarily secret, they just have secrets beyond what most people think the Arkivists do. Those who are publicly known as Arkivists tend to be archaeologists, curators and the like. Any surface race that has not accepted that its homeworld is likely gone for good will view Arkivists with some suspicion, and the intelligence services of that race will probably have infiltrated or be monitoring Arkivists.

Remember that not all surface races will be technologically advanced. Some races were pre-industrial for their own Exodus and have not advanced since them, others declined from the level they had. Arkivists will in some cases be secret religions or heretical cults.

Arkivists have no central organization. Rather, each group of Arkivists knows others, who in turn know others, and so on. So a plot that involves Arkivists can easily become a road trip, following leads from one Arkivist or group to another. While the Arkivists have some similarities to the Ancients, the Arkivists generally desire to use their information, while the Ancients are mostly content to just collect it. Arkivists may have a significant quanta balance with the Ancients, but odds are that they already spent it getting information *from* the Ancients.

A starting adventurer might know about the Arkivists, either as a Friend or Favor, but is probably not a member of the group (a Secret). As an alliance of like minds that crosses species and beliefs, they are a good hook or plot item for the gamemaster, contacts, patrons, buyers or sellers of unique information.

## THE TRADERS

The Traders are not an individual species, but are a motley clan of species with a high overlap of nutritional and environmental compatibility. Their origin varies with the clan you talk to, but they clearly date back at least several thousand years. They do not have a home polygon, or at least the original species does not have one *anymore*. It was lost due to invasion, the Aeth or an internal conflict that laid waste to it, depending on who you ask. The Traders now exist as a fleet of several hundred zeppelins, each one being its own independent clan, generally flying with the prevailing winds in a circuit around Aethos that takes several years to complete. They are mostly self-sufficient and get everything else they need through trade, hence their name. Because of space and weight constraints, what they have to trade and what they are interested in trading is almost always compact and lightweight, and more often than not, they do not trade in physical objects at all, instead trading the knowledge needed to make physical objects. So, instead of a fine liquor, they will trade the exact process for making it. Lightweight or compact items of value may be actual objects for trade. Gems, rare elements, seeds, medicines, cultural artifacts and such may be available from distant parts of Aethos, for the right price. Traders are another place you would go if you needed some quanta for dealing with the Ancients.

As far as their own technology goes, Traders are very adept in the biological sciences, especially in regard to utilizing agricultural products and recycling. A Trader's zeppelin is mostly made of and powered by organic products, with exocaps filling in the gaps. The structure and skin will be from various alien woods and plants, hydrogen (or hot air) for lift could be generated biologically, and hydroponic farms grow the food needed for a clan of up to a few hundred people. Even oil for powering the diesel auxiliary engines (main propulsion is electric) comes from plant sources. This makes each Trader zeppelin unique and constantly evolving.



Because of a time in *years* between revisiting a particular polygon and their dependence on their zeppelin, Traders are an exceptionally cautious lot. They will normally scout ahead for information, either by sniffing the radio spectrum, asking questions of those they trade with, or sometimes even using small recon blimps to physically scout a territory long before the main zeppelin arrives. Traders will often anchor their zeppelin to a calm spot for weeks to make a decision, and if there is even the slightest doubt about a friendly reception, they will skirt around a polygon or nation within a polygon. For instance, they will not go anywhere near Cartoo-held territory under *any* circumstances. Even in friendly territory, Traders are cautious. Their zeppelin will never land, and will position itself for maximum visibility and minimum vulnerability.

Traders are, as mentioned, a pan-species group. If you have sufficient skills or goods to trade, and the clan is willing to accept you, you can become part of the clan, and there are a handful of humans on the various Trader zeppelins. Traders actually prefer to have a representative of the species they trade with on their crew, as it gives them an edge when dealing with that species. Because their society is based on lighter-than-air craft, Traders will not accept new members unless there is an opening in their weight allowance. If you and your possessions are going to add 200kg to the zeppelin, then 200kg of lift has to be free, either because of a death or departure or you buying out someone's cargo allowance. Similarly, internal trade on a Trader ship is a complex valuation based on the utility of the good and its weight, since everyone has to pay a share of operating expenses based on the weight of themselves, their possessions and any of their personal tradeable cargo stored. A fat Trader is a wealthy Trader, their weight evidence of sufficient internal credit to haul it around on a weight-sensitive zeppelin.

Terran territory will see a Trader zeppelin each year or two, depending on current diplomatic tensions. The Terran government is *always* interested in having Traders show up, as they can provide data on areas too far away or too culturally alien for normal information channels. However, the Traders see the obvious threat to themselves if they should do anything that might be interpreted as 'spying', so it is a two-way street. Everyone knows that if you ask for information about a culture or geographical region, the Traders will only trade you as much detail as they can get from you on the same subject, information they will in turn trade to the people you were asking about.

**!** To be a former member of a Trader clan is an Unusual Background, and would let a human adventurer have some unique contacts, or allow a player to, with gamemaster permission, be a member of an alien race from a distant part of Aethos. However, Aethos is designed with human adventurers in mind, so be wary of the idea of non-human adventurers.

For the gamemaster, the Traders are a plot device, a way for information and odd objects to arrive from very distant places. Distant places that are inconvenient to get to, since the Traders will not see that location again until they make another full circuit around Aethos.



## THE AETH

As we have mentioned, the Aeth are something beyond human comprehension on a number of levels. However, the following is what the gamemaster should know and which maybe players or some really insightful adventurers can figure out.

The Aeth are *not* so highly evolved that they *cannot* communicate with more primitive intellects such as humans. Rather, they are so highly evolved that *we* simply cannot understand what they are saying. Much like a person can growl at a dog or hiss at a cat to convey a meaning, the Aeth *can* speak flawless English to convey meaning. This meaning however, lacks inflection and ninety-nine percent of the context behind the Aeth's actual intent. If you growl at a dog, it understands that you are unhappy, and if the dog has some experience with you, it might recognize the unhappiness has to do with that mess it left on the carpet, but it lacks the subtlety and information content about an 'expensive rug', 'that's the last straw' and 'it's off to the animal shelter with that dumb animal'. Similarly, an Aeth that deigns to communicate with a human will convey a clear intent or statement, but not necessarily a reason for it that the human can understand. That is, the long and detailed explanation an Aeth might make to a human in English means exactly as much *to the Aeth* as a growl does to a human when the human growls at a dog. An Aeth who deigns to communicate at even this level is a rare thing, and even rarer for adventurers to be on the receiving end, but it *has* happened. And each such growl/utterance has been dissected for centuries to try and figure out some new insight about the Aeth. *With little success but much speculation.*

A smart human *can* actually grasp *very* basic Aeth concepts, if an Aeth puts the effort into training the human. You can teach a parrot to understand the difference between colors and shapes, and tell it to 'put the red ball in the blue box'. But, that parrot is incapable of teaching these concepts to other parrots. The same applies with the Aeth. Any surface dweller (human or otherwise) that an Aeth has bothered to teach (for whatever reason an Aeth would do this) will find themselves unable to impart this information to anyone else in any useful sense. An individual who *can* understand any Aeth concept is by the standards of most surface races, driven insane by the knowledge. You have to either trust that person knows what they are talking about even if it *seems* insane, or assume that they *are* insane. *Maybe both.*

**Aeth physiology:** No one knows what an Aeth *actually* looks like. Over the centuries, Aeth have been seen and photographed, so *that* is not the problem. The problem is that no two Aeth are alike. Humans do not know if the Aeth are naturally multimorphic or amorphic, if they genetically modify themselves, or if a given body shape is merely the equivalent of clothing that an Aeth changes at will like humans change T-shirts according to their mood. Aeth are about the size of elephants, and they appear to breathe air, drink water, can eat from alltrees and most other surface food crops, and are comfortable in about the same temperature and surface gravity as humans are. How much of this is natural, preference, technology or genetic modification is anyone's guess. From the collected records of humanity and other races, Aeth have been seen everywhere on the surface, including the radioactive north pole during interstellar flight and the frigid south pole, and no external differences in the Aeth have been detected to indicate they needed extra protective gear for these conditions.



Huge, by Christian Bravery  
thebrave.cghub.com



*Information purchased from our normal Ancient source (reliability:9.1) suggest that the climate disruptions from Aethos' drive activation will, at Earth's latitude, cause dustfalls in the 1 to 3cm range, composed of non-abrasive semi-organic debris with no lasting effects on agriculture. Solar output will drop to near zero for several days then improve towards normal on a near-exponential scale, depending on rainfall. Preliminary casualty estimates for those who refused evacuation orders is 130,000. Economic damage is still being tallied, but is expected to be between 20 and 30 billion Eur.*

*- internal TSO report*

## INTRODUCTION

If as a gamemaster you have gotten to here by reading straight through the rules, you should already have half a dozen adventure ideas in your head. *If not, we have failed to make the setting cool enough...*

An **Aethos** campaign can begin anywhere and at *any* time in Aethos' history. *Aethos is merely the setting.* You can start immediately after the Exodus, at the beginning of the first Earth-Cartoo War, or any time after that. However, the gameworld notes, adventurer creation and politics are meant for a campaign that starts right about the time Aethos begins its century-long deceleration into a new solar system, what everyone calls the Arrival. This means that human adventurers of reasonable age could conceivably live long enough to see the final outcome of the events they shape.



For Terrans, this is the first time they have gone through this chaotic time. The Tuaqq have only been through it once before, and internal strife and external forces almost wiped them out. The Cartoo have been through several Arrivals, as have the Drinn. The Cartoo claim to be the eldest race in this polygon and that this gives them some sort of special voice that should be heeded, but the Drinn are actually more ancient.

The cultures who have been through several Arrivals can time the start of deceleration down to within a few months. They evacuate any Belt settlements, withdraw from any major maneuvering vents and shut down any suborbital transport systems they have. Terrans do not get completely on the clue bus and suffer some losses as a result. They are also suffer some losses by being suckered into bad positions by the Cartoo, who withdraw from untenable regions just in time, leaving human forces, settlers or technology exposed to the side effects of drive activation.

Starting up the maneuver drive scours the Belt of all non-scarth material in a matter of hours. Minor attitude adjustments via maneuver vents sterilize thousands of square kilometers of formerly fertile lands, and both cause extreme changes in the weather for a few weeks, with effects that linger a few months.

*This is about where things should start.* The stable, predictable life on Aethos is turned on its head. Electromagnetic interference sharply cuts into communication ranges, sub-orbital transport is shut down until it is determined whether it is safe, the reliable rains become erratic, and there is a week-long fall of dust from the Belt up from the equator up through the temperate latitudes of Aethos. The Tuaqq have high-density fiber optics in place to handle their electronic communications and booster transmitters to overcome interference. Other races will have similar precautions in place to maintain vital parts of their culture, technology or social infrastructure. Humans, not so much.



This is the *first* time this has happened for *humanity* on Aeth, and despite a mostly united, scientifically literate populace, it causes a short period of social breakdown. Not across Earth as a whole, but there are numerous cases of rioting and looting, border skirmishes with the Cartoo, lots of breakdowns and overloads in the computer and communication networks, choked roads in a few instances where whole populations tried to flee towns or cities, overloaded the smart roads and caused traffic jams kilometers long, and general chaos. This only lasts a few days and most of the side effects are cleared up in a few weeks, but it makes an excellent point to start a campaign, just as the air starts to rumble from Aethos' massive maneuvering drives firing up. The situation can bring disparate adventurers together, or give a group an early workout or introduction to some of the players who will affect their lives later in the campaign.

The Biblists say that this is the prophesied sign of the Last Days, and to top things off, next year is an election year for the Legislaat, which often means a new Executive. Terran government has become inefficient, bloated, some say corrupt. Population and resource pressure is having a negative effect on the economy, and prices for manufactured goods and food are going up. Voices once thought radical are now gaining political traction, and the sheer unknowability of what is to come is bringing out irrationality in many segments of Terran life, as well as that of other nearby surface races.

### Campaign structure

There are two ways of running your Aethos campaign. The first is the straightforward linear model, where you start at 'time A' and go forward in 'game time' as the adventures progress and plots unfold. The other, as used in **WarpWorld**, is the punctuated model, where the timescale of adventures and the time between them increases as the campaign progresses. You would use this sort of campaign if you want the same group of adventurers or the same campaign to be running when Aethos reaches its destination, most likely for the 'big finish', a resolution and likely the end of the campaign. *Or, if not the end, a new beginning...*

For plots and events, there are certain things to remember. Aethos is a giant interstellar spaceship with lots of aliens and mysteries and forces beyond comprehension, but it is ultimately a human setting. And there are certain things about humanity that a thousand years of diaspora and rubbing elbows with aliens will unfortunately not change:

- People will believe all manner of irrational things if these things buttress a belief they *already* hold
- In times of stress and crisis, enemies and scapegoats are found or invented
- Half of all voters are either below average in intelligence or above average in gullibility
- If it did not happen to *you*, your arrogance, greed or incompetence will cause you to make the mistakes you were warned about by the people it *did* happen to

These four things drive a great deal of human tragedy. And tragedy or more particularly, *averting* tragedy makes for great adventures. In **Aethos**, we have already described some plot threads that involve all four of these. Prophecies of dubious origin will gain enough credence to get political support by candidates of questionable morals. The Aeth or minority human groups or surface races will be blamed for bad things that happen.





And with the last survivors of the fifth Earth-Cartoo War dead and buried for nearly fifty years, a new generation of politicians will make the same bad diplomatic decisions and generals will, as they always have, prepare for the previous war and not the next one. The next several decades are going to be *very* interesting. Your job as a gamemaster is to convey this to the players in a way that interests them in what is going on and what they can do to change things.

For Aethos, this is probably the punctuated campaign, and the best way to one is this:

- Begin about when Aethos starts decelerating. Adventurers can hook up in one of several ways. They could be thrown together by some sort of deceleration-related chaos, they might be part of some clandestine government or private operation, they could be hired by a legitimate business or wealthy patron, all the usual ways adventurers get together. Run a few adventures, take a few months of game time to get everyone working together, give players a handle on Aethos, how things work and get an idea of the players' long-term interests.
- Jump forward anywhere from six months to a year of game time. Figure out what has gone on that the adventurers care about, and be ready to have adventures on these topics, or at least get the players enough answers to make the time worth it. Everyone gets a few extra experience to spend to represent downtime. This will be close to the major legislative elections, and makes as good an adventure backdrop as any. All sorts of shenanigans will be happening. Run one or two medium-to-long adventures to their logical conclusion.

- Jump forward again, about twice as far into the game future as the previous time, putting the adventurers an extra year or two into the future, with experience for this time, perhaps working any major use of experience into the first adventure (like buying off an Enemy or gaining Status or Wealth). You are now a few years after Aethos started decelerating. Again, you run a few short adventures and a few long ones. Plot threads from early on become more significant, maybe more sinister.
- *You can see where this is going.* If you jump forward about twice as far each time you put a break in the campaign, you can have game time restart at: 6 months, 1 year, 2 years, 4 years, 7 years, 12 years, 25 years, 50 years and 100 years, with the last one being just as Aethos finishes decelerating and is a few months from doing whatever it is going to do. Adventurers, if they have survived this long, will be quite old, but they will also be very experienced and hopefully wealthy and powerful. But not so remote from things that they cannot be hands-on for one or two world-shaking adventures, ending the campaign with a bang.

The last way to run a campaign is a hybrid. Have your normal adventurers run things in normal game time for a few campaign years, then retire the adventurers. Then, restart the campaign with new adventurers a few years before Aethos stops decelerating, and have the previous group of adventurers be their patrons. This provides a tie-in to plot threads from the old campaign, and motivations for the new adventurers that are driven by the interests of the players, via the events that happened because of the old adventurers.



## Adventure and plot ideas

**Aethos** is a strange enough gameworld that it is *not* for the novice gamemaster. It does not include any full-length adventures as it is expected each gamemaster will want to tweak things for their own group of players. But as a setting, it includes elements for just about everyone: puzzles to be solved, battles to be fought, wierd gadgets and advanced tech to be exploited, dangerous and mysterious unknown places to be explored, intrigues afoot and the potential to be a part of something that will shape the future of humanity...or end it.

With that in mind, here are a few starters for your own adventures, based on the conflicts and stresses inherent to the setting. These are *not* full adventures, but ideas for you to set in motion and add your own spin to.

### The Lost Colony

There is an occasional rumor that surfaces about a lost colony of Terrans. The tale is that the Aeth transplanted a single territory of humans somewhere on the other side of Aethos. The reasons for this vary with the tale, as does the approximate location. The satellite reconaissance made by other races during the Departure from Sol is inconclusive, and merely shows a number of areas where the colony is not. And of course, a version of the rumor says aliens are lying about the images they gave or sold us and are hiding the lost colony for their own alien reasons.

If this colony was on the other side of Aethos *and* it survived, it would be about a hundred thousand kilometers away, and if it survived and prospered, it could conceivably have a population of several million people.

Practically speaking, there is no real reason to find this colony. It is simply too far away to be a trading partner, radio does not carry that far, and neither group of Terrans could help each other out in a crisis.

However, the Ancients would certainly pay quite a bit for confirmation of this colony's existence, and more for knowledge of its culture (somewhat less if it was found but extinct). In addition, the prophecies of the Final Testament refer several times to the 'lost tribe of Man' that will play a key role in the last days. If new information surfaces and a reasonable chance of finding the colony exists, the Biblists will fund expeditions to find it and bring back whatever knowledge they can. Such expeditions would include ultralong duration manned flights by Aethos-powered aircraft, balloon-borne cameras, land expeditions to other polygons to investigate leads and so on. And in the event the colony is found and the information discovered does *not* match with official doctrine, the Biblist hierarchy will use any means at its disposal to suppress these discoveries.

The lost colony, rumors, expeditions and their results can be a background item for several years of a campaign, and can occasionally affect the adventurers.

**The truth?:** This is a variation of the legend of the Kingdom of Prester John, a myth from Middle Ages about a Christian kingdom in the Near East, possibly founded by a wandering apostle of Christ. His kingdom was placed on various maps of the day, and the legend persisted until the 17th century, when enough of that part of the world was known to realize that if there was a Christian kingdom there, someone would have found it by now. But from the 12th to 17th centuries, the legend had ties to the Holy Grail, battles against Genghis Khan, emissaries claiming to be from the kingdom received by the Pope and endlessly copied and embellished tales that caught the popular imagination.

All these elements can be part of a long-term use of the Lost Colony.



Now, if the Aeth *actually* placed a separate human colony, it could have been as a hedge against the main group of humans dying off, an experiment by the Aeth, a simple matter of convenience, or even that the Aeth ship carrying that bit of Earth *had* been damaged by Earth's defenses and had to scuttle back inside Aethos for repairs. Remember that the Aeth do not have human motivations, and assigning them the 'normal' reasons for doing something is likely to be in error. The problem with a single small colony is that virtually all advanced technology would have been destroyed in the transplantation process, and with no friendly alien neighbors, the colony would have no means to bootstrapping itself back to a 21st century level of technology, few if any advanced science texts, and very few people capable of rebuilding a tech base. So, alone in a small polygon, these humans would have survived in isolation for the past nine hundred years, ignorant of the larger world around them except for myths and legends. Probably lacking the ability to refine the elements needed to rebuild an advanced technological society (germanium, tantalum, selenium and so on), and only having a limited supply of industrial metals like iron and copper, the lost colony would be hard pressed to get back to merely an Industrial Era level of sophistication. By all standards of most other Aethos cultures, primitive barbarians. On the other hand, Earth's transplanted biosphere is not the most desirable real estate to conquer, and if the isolated Terrans pose no threat, there is no reason for a hostile neighbor to wipe them out. They *could* make a nice underclass of laborers, doing the nasty jobs their alien overlords no longer care to.

If you want to have an alternate campaign, you can start an **Aethos** campaign *in* the lost colony, and begin play with outside explorers discovering it just as the next Approach begins and having their means of transport wrecked in the process. Imagine a small group of adventurers with irreplaceable advanced tech stranded a hundred thousand kilometers from home, in an area where humanity had not yet progressed past 1870CE. Add in that the local humans might be a client or slave race to aliens, and you have an entirely different campaign than the default, yet still using the same setting and with the same long-term events in the background.

The Lost Colony would be a sort of miniature 'Wild West', with steam trains, hostile tribes living in the jumbled foothills next to a border and so on, all in an area maybe a hundred kilometers across. Imagine one large city of a few hundred thousand, based on the ruins of an Old Earth city (complete with dangerously crumbled underground ruins), a short rail line to one or two smaller towns on the outskirts of the territory, several small towns of a few thousand people (each run by a local noble), large farms on the side of the polygon getting the most rain, and jumbled, maze-like territory passable only on foot on the dry edge of the polygon, inhabited by savage hunter-gatherers who are masters of stealth and tend to kill all outsiders (possibly to protect some plot-important secret). Technology would be at the level of primitive cartridge firearms, which would be expensive because of the paucity of iron. Not to the level of being a precious metal, but scarce enough to be too expensive for anything that does not absolutely require its strength. Even things like steam engines would only use iron for the parts that absolutely required it.



Religions would be completely different than the rest of human culture on Aethos (much to the chagrin of the Orthodox Biblists), and government could be whatever form makes things interesting. It could be ideologically dangerous if it turned out one of the preserved relics of the Lost Colony happened to be a historical or religious text that would upend one or more of the fundamental tenets of Biblists, Seekers or Joodists (or even Aethologists).

A monarchy with titled nobles would be a nice throwback system. To add some intrigue, the lost colony could be set on the repaired **Scar** (another scenario idea), making the rubble between the colony and the underlying scarth a *very* valuable commodity, one which the main Terran population might want to exploit, but also one that aliens might wish to possess. And the main Terran force and its high tech weapons are a very long way off. You could think of it like the Russians and British fighting over Afghanistan in the late 1800's. Neither can get a huge army there, but both sides are willing to fight over it and want to get the locals on their side. The distance from home makes high-tech goods irreplaceable, and leadership of any kind becomes a matter of personal responsibility (or blame). While credit for success might have to be shared with those who sent you there, blame for failure is going to be yours and yours alone.

### Campaign effects

Back on Earth, the discovery of another group of human survivors would be major news for a few weeks. If it had been confirmed remotely, there would be all sorts of expeditions planned (and the Cartoo will consider an expeditionary force, just to be obnoxious). If it was found via expedition or after an expedition had returned, those involved in the expedition (especially the leaders) would be hotly desired guests for talk shows and there would be opportunities to profit. Academics with appropriate connections and media savvy might get temporary gigs as consultants on news networks. Someone will want to make a documentary, someone else a drama, and the most prominent or dramatic figure of the discovering group could get a book deal out of it.

All of this could be translated by a gamemaster into an award of a level of very limited Status (*"Hey, aren't you one of the people who discovered the Lost Colony?"*). This is optional. An adventurer can always shun any publicity associated with the event, unless they were leading the group that discovered it, or had actions so dramatic and important that the media just will not let them alone. In addition, everyone would get an award of 2 or more points of Savings to represent increased economic opportunities above and beyond the normal amounts. Just being part of the group is worth 2 points of savings, while being the one most in the public eye could be worth 12 points. Any adventurer who chooses to put some of their experience towards Wealth gets +1 point more than they allot (so if you add 1 experience towards Wealth you actually get 2).

If appropriate to the plot and the actions of adventurers, traits may be gained or bought off. New Enemies or Friends are possible, for instance.



## The Scar

Another rumor that surfaces every century or so is 'the Scar', the remnant of a cosmic impact large enough to pierce the shell of Aethos. This supposedly happened many millennia ago, but according to the variations of the rumor, it still has not been repaired. This is usually ascribed to the Aeth lacking sufficient scarth to do so, that the Aeth are merely passengers (albeit advanced ones) and lack the technology to repair it, or because the Aeth are fighting an internal civil war and no one wants to spend the effort on repairing it. Since Aethos has not been completely mapped, this rumor has the potential to be true, though if it is true, it is probably more of an embellishment of a more minor event. Biblists use the Scar as evidence that the Aeth can be hurt. Explorers see it as a potentially unguarded opening into Aethos, and treasure-hunters imagine the size of scarth pieces that would surround such an impact site. Con artists will alternately try to get funding for expeditions and then disappear with the money, or claim to have found it and sell shares in a corporation to exploit the find. Sometimes scammers will set out on an expedition and it will 'mysteriously disappear'. Sometimes they will buy up scarth bits on the open market for several years and then present them as finds from their discovery, and keep the bits trickling in until they get enough investors to cash out and run. The scams are done with a remarkable degree of sophistication, and invariably fool a number of wealthy and intelligent folks, some of whom are willing to go to extra-legal means to get their money back or get revenge on the scammers.

The Scar is not an exceptionally important item in the scheme of things, but it is an enduring myth because it has *just enough* evidence to make it plausible, has the potential for a great deal of profit and is an interesting story. Some other races have a similar myth, which adds to the tenuous evidence it is true, but the false evidence that has been fabricated over the centuries makes separating any real evidence from fakery is almost impossible. It is a treasure hunt that has gone on for centuries, with some in every generation succumbing to the allure, like the Oak Island treasure or the Beale Cipher. Even those who do not believe in it, believe in the paychecks they get from a wealthy backer who *does* believe in it.

There are a couple ways in which this could be presented as an adventure. The first is the civilized intrigue and double-dealing associated with hidden treasure. Maps or artifacts related to the search could be stolen. Experts on the myth could go missing. *Are they just on a very strict non-disclosure contract? Were they abducted to gain knowledge they are hiding? Or are they hiding to avoid being abducted?*

The other is as part of the exploration itself. There will be scientists and security personnel. There will be deceiving potential competitors as to where you are going and when you are leaving. There could be a race by competing groups to reach and claim the same location. There might actually be an alien race there already. Or, some aspect of the Scar story might be true, but after finding the real thing, adventurers discover that someone else made off with the booty centuries ago.

**The truth?:** If the Aeth are as presented, a scar of this magnitude is unlikely, especially of this age. The Aeth would have repaired it long ago. But, if one (or more) of the rumors about the Aeth is true, then such a scar *could* exist, though it would still probably be far smaller than described. It would still be *immense*, on a scale of the Valles Marinaris on Mars, and probably exposing the next layer of Aethos.

The problem with the rumor is that humans are not alone on Aethos, so a feature of this size would have been noticed by someone, especially during the final approach to a new solar system, when recon satellites can be launched. What is more likely is that at some point in the distant past, such an event did happen on the forward ablation shield. It was repaired and then covered up with new rock and soil from the next system the Aeth visited. The profit from this is that if you knew where it happened, that region of the ablation shield would be rich in scarth dust and fragments, enough so that mining it *could* be a very profitable proposition.

### Campaign effects

As we said, the Scar surfaces every century or so like a fabled lost treasure. Someone may lose a bit of money on it, someone may gain a bit. The biggest winners will be anyone who gets a paycheck off the affair for several months, assuming they were smart enough to get paid in cash rather than in shares of the operation. There are not likely to be any major effects in the lives of adventurers involved, and experience gained would be normal.

A possible tie-in to another adventure would be to have the recovered logs of the *Bats over Barstow* show patterns of scarth dust distribution that could be correlated with weather patterns to localize an event of the Scar's magnitude. This might be thousands of kilometers upwind of the *Bats*, but it would be the first new, verifiable data to support the Scar story in a long time, and give an inside track to members of the *Bats* expedition to get on any team exploring the northern latitudes for the Scar.

### Ghost Ship

One of the better documented rumors (at least in top-secret government circles) is one about the Earth Defense Ship *Tiberius*, involved in the failed attempt by Old Earth to repulse the Aeth. *Tiberius* was a fusion-powered destroyer of several thousand tons, armed with particle cannon and lots of fusion-powered missiles of various kinds (enhanced radiation, crust-busters, etc.). *Tiberius* had its fusion plants disabled over Aethos after expending its missile load (a near-miss by an Aeth weapon shredded the rear of the ship rather than vaporizing the whole thing). Equipped with an aerobody hull for possible use in Aethos' atmosphere, it made a hard but survivable crash landing on an uninhabited part of Aethos' surface. Nothing else is known except that a short transmission was made back to Old Earth by the surviving crew after landing. All of this is known only from hand-written records of Old Earth military personnel who were transplanted here by the Aeth, as all the digital records were destroyed by EMP effects during the transport.

It is unlikely that there are *any* descendants of the *Tiberius*' survivors. They would not be equipped to survive on a desolate patch of dust-covered scarth and its minimal, alien ecosystem. However, the ship itself may still have recoverable elements. In particular, its computer cores should hold a wealth of information about Old Earth, as well as the full tactical records of any Terran/Aeth military engagements. The access codes for these computers are a closely held government secret, hardcopies dug at great cost from the wreckage of government buildings and preserved for the past nine centuries just in case this ship is ever found. Theft and recovery of these access codes could be an adventure all by itself, one which adventurers would have no idea is tied to *Tiberius* until sometime later on. Or someone might stumble upon new information about *Tiberius*, which the government will work to get a hold of and keep secret.



Also secret are laws regarding the salvage of the *Tiberius*. Even after more than nine hundred years, *Tiberius* is considered the still-classified property of Earth's government. If the *Tiberius* is ever found, the Terran government will act with all possible speed and force to claim and occupy the wreckage. The finders will *not* be compensated for any effort made. In fact, the Terran government will only agree to drop trespassing and theft charges against the finders in exchange for signing a *severe* non-disclosure agreement about the discovery, returning any and all artifacts already removed, *all* copies of *any* records involving the discovery, and a list of *all* people involved in the expedition *or* its funding.

Of course, anyone who is actively searching for the *Tiberius* already knows that it is a government secret, and will impress upon any expedition the need for absolute secrecy. The funders of the expedition will probably hire people it knows can keep a secret, or make sure that the secret is kept, by eliminating any security risks after the discovery is made. To put *players* in the proper frame of mind, such an operation would be like an expedition to recover working fusion bombs from a military jet that crashed in the ocean. You know that you are doing something that the government will not approve of and will most certainly stop you if it finds out. And you can imagine the lengths to which the backers of this recovery would go to avoid discovery or culpability. Once the *players* understand this, their *adventurers* can respond appropriately to any employment overtures or leaked or overheard information they come into possession of.

It is possible that other EDF ships crashed or crash-landed on Aethos, but *Tiberius* is the only one known about. As a result, anyone searching for *Tiberius* may also encounter rumors or tales from other races or travellers about wreckage or suspicious pixels from old satellite recon missions. Plus, there could be even more ancient wreckage from other races scattered about. Aethos is a *big* place, and much of it is still unimproved scarth with whatever opportunistic plants and animals have managed to find a foothold there. Large pieces of debris (like crashed starships) are small windbreaks that dust will collect around and moisture can collect under. Over the course of several decades, they will become small hills covered in alien plants, the nucleus of an ecosystem. Over the course of several centuries, they will be indistinguishable from any other part of the landscape.

**The truth?:** Somewhere out there, the *Tiberius* actually *did* crash, and some of the crew *did* survive the landing. More than that is speculation. Did the crew die of starvation? Did *Tiberius* crash land in a central sea and sink? Was the crew captured or killed? Did they leave any clues behind that would help unravel the mystery? *That's up to the gamemaster.*

The Ancients don't know anything about it, and they would probably sell the information if they had it, unless they considered any data or artifacts from *Tiberius* to be militarily useful. It is equally certain that in the long history of Aethos, the *Tiberius* is not the only ship to have crash landed here. One thing would be certain, though. No ship with a working fission, fusion or antimatter power plant or weapon would have survived to make it close enough to land on Aethos, limiting the technological potential of such finds.



### Campaign effects

If the *Tiberius* was found, there would be several items of importance for its discoverers. First is the solving of an ancient historical mystery. Not worth much in tangible terms, but it could certainly make someone famous, and there are always the movie rights to the story to be sold. *Provided you can do so in a way that does not get you locked up for violating state secrets.* Second is weaponry. While *Tiberius* will have no functioning nuclear devices, it was equipped with advanced superconductors, high energy lasers and the best ECM suites money could buy. Some of these might even have technological insights that humanity has not yet figured out again.

Last are the computer records of *Tiberius* and personal devices. In addition to the encrypted sensor logs and other military data, there would be non-encrypted entertainment files, technical manuals, personal logs and other library materials. Remember that by the time of the Exodus, something the size of a paperback book could hold several thousand volumes of flat text and several hundred multi-media files. Even if all that was recovered was a single one of these devices, the contents would probably double Earth's knowledge of Old Earth and be worth several million Eur. Even the equivalent of an earring-sized music player would have a fortune in Old Earth music on it. Remember that all of these would be in computer protocols that no one has used in a thousand years, and the only devices capable of playing them back are the artifacts themselves, which are highly unlikely to be operational. Odds are it would take years to decode the data, if the data is recoverable at all. Adventurers might sell such a device for a fortune and the buyers might never be able to utilize its data. Or adventurers might spend a fortune on one, not realizing that someone else has already discovered the data is irrecoverable.

On the other hand, some of New Earth's most prominent family lines were probably *not* Old Earth's finest citizens. If their own secret, very embarrassing family histories were in danger of being unmasked by historical records on genuine artifacts from Old Earth, the patriarchs of these families would probably pay quite handsomely to make sure they were the ones owning that information, or failing that, make sure it never saw the light of day. Even though it would be meaningless after all this time, matters of family pride are too often *not* subject to reasoned debate and logical actions.

And all of this presumes that the Terran government does not swoop in and confiscate everything found and seal it with a gag order, or that the Cartoo don't swoop in and take over the wreckage by force and loot it.

There are plenty of things that could happen to adventurers involved, depending on how, why and the nature of their involvement. They could pick up the TSO as an Enemy, a Friend or both. Simply knowing about the *Tiberius* and having the government know that you know is worth a level 3 security clearance. This does not grant the adventurer any right to know anything else at any other level of clearance, it just means the adventurer is legally bound and liable for the consequences of revealing level 3 state secrets. Unfortunately for the adventurers, knowing the penalties for revealing level 3 secrets is *also* a state secret, one which they are *not* cleared to know...





Managing to get out of the scenario with your knowledge of the affair kept secret is itself a Secret (as in the trait of that name). This does not normally net an adventurer any points, but they would pick up the TSO as an equal value Enemy should the secret be revealed. This means that profiting off any knowledge or artifacts gained would be exceptionally difficult. However, someone taking a Secret should be able to spend the value of that Secret on increased Wealth to represent black market sale of knowledge or artifacts.

It would be hard to peddle Old Earth digital music without explaining how it survived getting to Aethos, and anyone who knows about the *Tiberius* would immediately see the potential connection. A similar connection would be made for any data from Old Earth personal computing devices. So, such sales would have to be anonymous and preferably through middlemen. Adventurers without the skills or knowledge to engage in such black market transactions probably cannot turn the Secret into cash. If they could, and played it right, they could be set for life (several million Eur).

It is possible that in the long run, a successful backer for the expedition might be later apprehended and investigations made to uncover their underlings, which could cause problems for adventurers not smart enough to have an alibi in place to explain where they were during the time period in question.

## Election Rigging

The Conservative Biblists, under the banner 'the Right Path', are supporting a number of candidates in the next election (which is about a year after Aethos starts decelerating, or about a year into a campaign). Under their core philosophy of 'the ends justify the means', they are engaging in a number of overt and covert means to get as many votes as they can. Note that 'the ends justify the means' is *not* a party platform, just an apt description of their tactics. Some of the 'means' include lying about their non-Biblist opponents while simultaneously claiming the moral high ground, filing defamation claims and ballot challenges to tie things up in court, and generally being complete wankers in private while presenting an upright public face.

They are well aware that even if they have seriously bent or broken election laws, once they win, they will be the ones in charge of investigating these potential violations. As long as they can get a majority or form a majority coalition, they are not worried. This is not a new thing in Terran politics, and is almost 'business as usual'. It is just now that Aethos has begun decelerating, the stakes are higher than normal. Completely unaware of the Old Earth parallel, one of their slogans is 'The Hundred Year Reign'. They want to get into power *very* badly, and if they do, they will *not* let go of it willingly.

! Yes, we are using Conservative Biblists as 'bad guys', but that does not mean that Biblists in Aethos are bad people any more than the majority of Germans were bad people during World War 2. What it *does* mean is that a group of people have hijacked, demagogued or otherwise manipulated the system so that they can use Conservative Biblism to foster their own ambitions. These ambitions *may* be because of their personal apocalyptic interpretation of Biblism, or they might just be poseurs wrapping themselves in scripture as a means of achieving secular wealth and power. *How you play it is up to you.*



This could be the start of a *very* long term plot thread, and to confuse matters, Conservative Biblists might be *bad* guys, but not the *worst* guys. There will be *many* elections between now and Arrival, and this election is just the opening salvo. While they would have their faults, the Conservative Biblist faction *would* be a strong government, and without a strong government it is not just possible, but *likely* that Earth may face secessionist states, civil war or total anarchy. If not this election, then in a future one, adventurers may be put in the unenviable position of having to help put a faction in power that they really do not like, or seeing Earth come apart at the seams. Putting players in the position of having to choose between 'bad' and 'worse' really gives them incentive to be creative and come up with a workable third choice.

**The truth?:** Conservative Biblist leadership is probably bad for humanity as a whole. Not because they are Conservatives, and not because they are Biblists, but the two together and put in charge would be led by a small, radical faction that is completely immune to logic, reason and any argument that does not match its preconceptions. And this group will drag the more moderate elements of both Customs down with them, and humanity as a whole will follow. It may be that at some point in the next century, strong elements of Conservatism and Biblism in the government will be *necessary* to hold Earth together, but the trick will be figuring out when this time is, and when this time has passed and a different set of Customs will be what Earth needs to move into the future.

### Campaign effects

This is more of a background plot rather than a specific scenario that directly involves the adventurers. It is an ongoing set of someone else's plans that will occasionally intersect the lives of the adventurers, or it can lead to an scenario where the adventurers are actively trying to thwart some sort of shenanigans and hopefully remaining anonymous in the process.

If a Friend happens to be running for office, they may call in a marker from an adventurer and possibly drag the rest of the adventurers in as a side effect. A government group or maybe a probation officer that is watching an adventurer has a new leader with Conservative Biblist loyalties and is trying to use their position to influence the adventurers. A bureaucrat or police captain who does not approve of what the adventurers are doing can hold up permits or cause problems.

Unless things become really heated, the worst violence that is likely to happen is vandalism and intimidation by 'spontaneous' flash mobs at the rallies of non-Biblist candidates. There is no paper trail that would implicate anyone important, nor force any Biblist candidate out of the race. Adventurers involved directly or indirectly in such campaigning can double any experience they put specifically towards an Area Knowledge on Conservatives or Biblists (so if they assigned 2 experience towards it they would actually get 4).



## Squatters

Each race on Aethos has its societal outcasts, people who cannot or choose not to follow the 'acceptable' social norms for that race. Those who are mostly functional in society often become colonists, settling in uninhabited adjacent polygons, roughing it in somewhat alien ecosystems, far from the police, armies and social safety net of their central culture. This would be comparable to the Puritans fleeing England to colonize America. These groups are usually insular. They chose to live in the wilderness to get away from the problems of the society they lived in, and will not be happy if that society comes to visit them. Some will be xenophobic, while others have less animosity to aliens than to their own kind. A very few of these colonies are based on multi-species ideals and within bounds, have harmonious relations among races that ordinarily do not get along. For instance, a Cartoo who is *not* self-centered, who is *not* compulsively ambitious and who is *not* willing to break an arrangement if it is in their advantage to do so, is doomed to a life of misery and abuse among the Cartoo, but could fit in just fine in a human community. *But no mainstream human community would ever trust a Cartoo.* But a small fringe group might be more likely to judge a person by their actions rather than their phenotype.

Those who are further from the mainstream but have sufficiently motivated and skilled individuals will do the same, but in groups that usually are not sustainable in the long run. These groups tend to disappear or die off once their central personality or leader dies. You can call them cults and not be too far from the mark. Extreme religious or political views are the norm for these groups, and they are usually very hierarchical, with subservience to the creed or leader (usually both) being required.

Last are what translates out in most languages as 'squatters'. These are groups of some type that take up residence on or inside Aethos' access portals. This is real estate that most sane people avoid out of fear of the Aeth, yet is close enough to civilization to be accessible, either for disillusioned members to leave, or for new members to join. Since these locations are almost always at the junction between polygons, it is not uncommon for a good location to have squatter colonies of multiple species, who tend to live in peace, either cooperatively or by deliberately avoiding each other. This is mostly a matter of self-interest. No one wants to engage in actions that might cause the Aeth to take notice, so even if there are hostile feelings, avoidance rather than conflict is the usual strategy.

Squatters are notoriously superstitious about portals, and live and sometimes die by hearsay or unproven rules about portal safety, like "the Aeth never fire up a portal unless it is a prime number of years since the last time that portal was used", or "I heard that as long as the total population of sentients in the portal is less than four hundred thirty seven, it's safe."

Among humans, being a portal squatter is a Custom, a variant of the normal Squatter custom. This gives the Terran government a way to officially avoid having to chase squatters out of these spots, without actually having to take responsibility for their safety. Squatters merely have the right to live according to their own laws within an Aethos portal and free right to cross civilian territory to and from these portals. Squatters are bound by all other laws and Customs outside a portal.



The down side of the squatter life is that if the Aeth use a maneuvering jet or launch a ship through an access port, it will undoubtedly wipe the squatter colony off the map. With deceleration into another system beginning, many squatter groups are becoming restless and looking more fondly at living elsewhere. Those who have the skills and will to live in the outside world are strongly considering it, or planning to found colonies in safer areas. This could require accumulating the resources to make a long trek to an unoccupied polygon.

Squatters very rarely come up with Aeth artifacts. They have a near-superstitious dread of touching anything Aeth in a portal, and probably for good reason. But even the Aeth do not recycle things one hundred percent, and over the course of centuries might lose something here and there. What this stuff meant to the Aeth is anyone's guess, but it is certainly not anything important. A hanker-chief-sized chunk of micron-thin scarth that forms a stasis field around an object inside it? Maybe the Aeth equivalent of a discarded bubble gum wrapper, or maybe a spare part for a quark disruptor cannon. *No way to tell, no way to know.* The Terran government offers a generous bounty for these items, simply to encourage them to head into government hands instead of the black market.

This time, someone *has* come up with an object out of the ordinary, something capable of causing trouble.

**The truth?:** A group of mixed Neogian Squatters has wisely decided to abandon their portal colony and try to make their way across Earth to a colony in the next polygon that has offered to take them in. A small party agreed to stay behind after the main group left, to take the risk of searching and scavenging anything that might be worth a government bounty. This way, if they trigger an Aeth fumigation, only the scavengers get wiped out, not the whole colony.

The Neogians have little currency and some are off the net entirely, so taking normal transport is not an option. In addition, they want to be able to offer their new home more than extra mouths to feed. However, one of the Neogians has gotten tired of the lifestyle and wants to rejoin normal society, and for that, a nice chunk of cash would come in handy. So, when he finds a small, lightweight silver sphere crazed with hairline cracks, he carefully puts it in a padded box and does not tell anyone about it. The other searchers come up empty-handed, and they exit the portal, catching up with the rest of the refugees in a day or so.

What the searcher found was something *extremely* rare, an Orb. Rare enough that the average person does not know about them. Normally, just picking it up should have initiated a powerful but ultimately fatal transformation as Aeth technology turned them into some sort of intelligent war machine. This Orb is apparently damaged, but that does not mean it is non-functional. Through the hairline cracks in its surface it oozes a microscopic haze of Spores, which are going to eventually cause the person carrying the object to come down with a really powerful and potentially fatal case. Worse, the merely airtight seal of the padded box the damaged Orb is being carried in will *not* stop the spores, so a constant trail of them is left wherever they go, with higher concentrations remaining wherever they spend the night.

It will take several weeks for the group to work and hitchhike their way across Earth. Somewhere in this interval, the person with the object will come down with a case of Spores. A few days later, the first cases will appear among random members of the populace on their route. Since the entire population of Earth only has about a dozen cases of Spores per year, having several cases show up in a week gets a *lot* of notice in government circles, especially when the locations of the cases start looking like a line on the map.



When the person concealing the damaged Orb realizes they have caught a case of Spores, they panic. By group decision, the Orb would be group property, and the bounty would be for the group, not the finder. This would eliminate the cheater's nest egg for when they abandon the Neogians. Similarly, such a deliberate deception would result in them getting kicked out of the group, with no social safety net except the dole. So, seeing no other choice, they flee. This happens about a day or two before the health officials track down the Neogian group as the source of the infection. By then, the rogue Neogian is quite a ways away, in the throes of a minor transformation and thinking less rationally than normal, while at least one of the people he has left behind has also contracted a case of Spores, which may confuse the issue.

Somewhere in here is where adventurers could get involved. The news will be full of stories about the Spores cases, with pictures of the 'carrier', and the usual vague warnings associated with disease outbreaks. Knowledge of the damaged Orb is suppressed, but it is an open secret in certain official circles, as whoever apprehends the person carrying it needs to have some idea about it. Right now it is just described as a 'spore-contaminated artifact' from inside a portal. That is, if the authorities have figured out that the missing member of the squatters found something and probably still has it. The person carrying it will probably have a very severe case of Spores, and will quite possibly die from it, but not for a few weeks, by which time they could be crazy, nearly uncatchable or both. One thing that will remain in their consciousness is that *the Orb is valuable*, and they will be trying to find a buyer for it. This will require getting to a major city *and* finding a place to lay low, which will require some theft to get the currency needed.

### Campaign effects

For adventure hooks, the main victim might be someone an adventurer knows and wants to save from themselves. Maybe they have a patron who is interested in the person, the artifact or both, who wants to get their hands on one or the other before the government does. Maybe it is a Friend calling in a favor. It is possible the other adventurers were part of the Neogian group and merely want to get the artifact so they can claim ownership for the bounty. Or maybe the main victim is just a complication. Adventurers are working for someone shadowy and this hyped-up Spore victim shows up in a deranged state in the middle of a black market deal. Both sides in the deal see the potential value of the Spore victim and artifact, and a firefight ensues.

Exposure to the Orb for any length of time is almost certain to cause a case of Spores. In game terms, if the closest proximity as a distance level is maintained for 4x that amount as a time level, a case of spores is guaranteed.

**i** If your closest approach is a distance level of +5, then staying at that distance for a time level of +20 guarantees a case of Spores.

Lesser exposure would be an easy(5) Health roll to avoid, +1 difficulty for each +2 time levels of exposure. Since spores are Aeth tech, measures like trying to stay upwind might be ineffective. The active spores might travel upwind and through protective gear like it was not even there. *Or they might not.*



Consequences of Spore infection would be normal. Overexposure might make the case more severe than normal. This is a particularly unusual case in that *all* the spores are coming from the same Orb. Most cases of spores come from accumulated exposure to spores that have been drifting for centuries, from myriad sources. It is possible that there could be some common shared effect among those infected. It is more likely that this effect will only happen between adjacent infections, like you, the person infected before you and the person infected after you. This would be a unique effect generated by the gamemaster, and is likely to be both beneficial and annoying at the same time.

**i** You might gain the benefit of a permanent +3 to your Recovery. However, this comes at the cost of feeling and being affected by all losses of Stamina and Hits taken by either of the other two people you are linked to. If one of you falls down the stairs and breaks an arm, it will heal much faster than normal, but all three of you will have a broken arm.

This is something that can, with some difficulty be filtered out of an adventurer's blood. It might even be that the government will pay for the process, just to study that particular set of spore remnants in detail.

For other long-term effects, the actions of adventurers might give them a Favor, Friend, Enemy or very limited Status among the Squatter or Neogian communities. If there is an interaction with the Cartoo in the **Saber Rattling** scenario, it is possible to alter the level of any Cartoo enemies an adventurer might have, or play into any Friends or Enemies amongst the Terran military or possibly State Police.

## Saber-rattling

A river flows down the Mieres-Cartoo border, into the windbreak sea the two territories share (the jumbled terrain where transplanted regions touch easily erodes and has natural contours that make rivers common). The negotiated agreement with the Cartoo (the ones running that area) is that both Terrans and Cartoo may use the river, but that setting foot on the wrong shoreline makes one subject to immediate arrest. And there are plenty of sensors and guard posts on both sides of the river to detect and enforce this. A recent flood has slightly altered the course of the river, putting a small island in a new bend. This island used to be on the Terran side of the river, now it is an island in the middle of the river. One morning, a Cartoo guard post and weapon emplacement was there, and the Cartoo claim that it is *in* the river, so they can use that land as they see fit.

The Terran government does not see it that way, of course. The Cartoo are just pressing the Terran government to see what happens, and have upped the ante by putting the son of an important Cartoo figure in the guard detachment, making it politically impossible to just shell the Cartoo post out of existence.

**The truth?:** There really is not any. It is a tricky diplomatic and military situation, and the Cartoo are yanking Terran chains just because they can. The Cartoo are behaviorally compelled to push at limits. If the local Cartoo commander had not claimed the island, there is a good chance he would have been ousted by an underling who would. So, even a 'moderate' Cartoo would probably have done it, just to avoid weakening their position of leadership.



This event can be a complicating factor for an adventure in the region, as the Cartoo provocation will result in more troops on the ground and sensor drones in the air. Anyone trying to do something clandestine will probably go to ground. A possible complication could be for the spore victim in a previous adventure outline to be in this area when they start to become irrational. Some hidden species-defense coding in the Aeth spores might compel this person to defend Earth, and possibly provoke a brushfire war if they kill the Cartoo heir commanding the contingent on the island, or cause a human response if the Cartoo shoot up an 'unarmed civilian'.

Regardless of how peacefully or violently the matter is resolved, the most likely outcome is that the island or that entire border area will either be declared off-limits to everyone, or that Terrans and Cartoo will shell the island into a mudhole that will wash away in the next minor flood, thus restoring the status quo.

### **Campaign effects**

This scenario is more of a complication for something else that is *already* happening in the region. Bad weather might have stalled progress of adventurers heading elsewhere and they awake to find the area under martial law, with travel and movement restricted until the situation is resolved. Those who are military veterans might be asked to help by any local militias. Any trade or diplomacy intended with local Cartoo factions becomes dicey with the potential shifts in local power.

Contacts that might turn into game relationships might be made, but there are no other major effects on any adventurers caught up in the situation. This setting combined with the Squatters adventure seed could be a good starting point or complication in the first real adventure the players have.

## **The Wall**

Not really an adventure idea, just a potential setting for one. The Aeth did a passable job of matching elevations and terrains when laying down the various parts of Old Earth onto the surface of Aethos. Hills generally match hills, plains with plains, even rivers tended to be fairly close to other rivers. A notable exception is the Wall. This is a chunk of cliff a couple kilometers thick that is the western tip of Johannesburg. When placed, it was flawless and vertical, rising from the sea to the high plains as sheer cliff over two kilometers high and several kilometers long. Time and weather have marred this perfection, but it is still by far the most impressive geographical feature in the polygon. Other cliffs were higher at first (especially on the east side of Kathmandu), but the Wall has not crumbled into scree like all the others. *At least not yet.*

And humans being humans, some of them want to climb it, jump off it, or both. Climbing is by far the more dangerous of these two options. The Wall is constantly shedding rock. Maybe not like rain, but over its length at least one boulder-sized chunk comes loose each day, and dozens of fist or melon-sized ones splash down each day. A good climbing helmet is not going to save you from one of these. A boat crew with a good radar can give you some warning, but the ascent is a multi-day affair and you have to sleep *sometime*.

The Wall generates its own microweather. When prevailing winds are off the sea, it pushes warm moist air straight up, making the stone slick, with impenetrable fog. When the wind is from the other direction, the cooler air at the top sheets down the Wall in a high-speed river. Either way, base jumping from the top is a risky proposition and several climbers or jumpers lose their lives there each year.



## Second Exodus

It is not unique for a transplanted race to try to 'jump ship' when the Aeth arrive at a new system. Successes at this are rare, mostly because the Aeth ravage the most habitable world in that system and systems with two habitable worlds are *very* rare. However, such systems *can* exist, and the Aeth have sometimes run through systems advanced enough to have self-sufficient orbital colonies. As a side note, systems that advanced usually put up a hell of a fight when the Aeth come calling, as they can often access significant quantities of antimatter and can accelerate good-sized rocks up to fractional lightspeed to use against Aethos. The Aeth have still won all such conflicts but also tend not to transplant any race that offers that level of resistance. The surface of Aethos (and those living on it) may be in for a rocky ride during such Arrivals. The point is, even after the Aeth leave a system, that system may remain capable of supporting the same sorts of life as live on the surface of Aethos, even if the planet the Aeth strip-mine is not.

So, some races invest a lot of time and energy into plans for a fleet of ships capable of getting a sufficiently large population off Aethos at close approach, to land on any remaining habitable planet or gain refugee status with any surviving culture in that system. Or at worst, make do with any marginal planets that remain and hope for the best. To some, trying to rough it on a Mars-like planet and be free of the Aeth is better than staying on Aethos. This idea is not necessarily something with universal support. Many people, having been born on Aethos and having a family tree going back on Aethos for generations, consider Aethos, however bizarre, their *home*. The idea of massive taxation and hardship to build a small fleet of ships to carry a tiny, tiny fraction of the population to somewhere else is not all that popular an idea. So, governments that try to do this often use subterfuge and force to bring it about.

This would be a major, probably multi-generation effort. While advanced materials give an increase in efficiency, the rockets used to boost such colony ships into orbit have to be chemically powered. The ships would probably be built in low Aethos orbit once Aethos slows down to a non-relativistic speed (probably the last decade or two before arrival), and use solar-powered ion rockets for their final journey. It would be the equivalent of hundreds of Space Shuttle flights to build a *single* colony ship. We are talking about a ship capable of carrying thousands of people for possibly months of slow deceleration, sufficiently robust re-entry vehicles, and enough supplies and technical infrastructure to be self-sufficient in a potentially hostile ecosystem or environment. Each ship would be a spacecraft of perhaps ten thousand tons (for reference, the International Space Station is less than five hundred tons).

How many colony ships a surface race could make depends on how much political will they have to wreck their economy in the process, and whether their neighbors are peaceful enough to let them weaken themselves in this way without acting. There are records of races on Aethos that went extinct after trying for a second Exodus and weakening themselves fatally in the process. Seldom do the records indicate whether or not the second Exodus was actually successful. In the long term, it is difficult to tell. There are ruins of long-abandoned communication sites near the frigid south pole of Aethos, apparently designed to send and receive messages to whatever system the Aeth were *leaving*, but these are several thousand years old and have been looted of all data and useful equipment. Sometimes the actual structures look to have been reused by other races as exploration outposts. The Ancients would no doubt have info on some of these efforts, for the right price.





Since an Arrival is not something that sneaks up on the surface races, any government interested in it will have voluminous (and probably secret) plans regarding a Second Exodus, with timetables and contingencies and protocols and specific actions to be taken to determine if a Second Exodus is even possible at this particular system. And of course, there is always the selection process to determine *who* gets to be part of a Second Exodus. A clear need of the selection process will be people who are willing to obey orders without question and handle lots of hardship without cracking under the stress.

The first step in any Exodus preparation is to do an astronomical and radio frequency survey of the new solar system. The best possible observatories would be at the north pole. This is almost like a space mission all by itself, and will only be practical once Aethos has slowed down for a number of years. Until then, observers will have to settle for northern latitudes above the equivalent of the arctic circle, a dangerous but sustainable mission. Until radiation and radio spikes from debris impinging on Aethos' magnetic field decrease, any real communication or detection of faint signals from in-system will be difficult. Similarly, orbital activities will have to wait a few decades until it is safe to put something in orbit. All orbital activities are going to be tricky matters of timing as long as the maneuver drive is operational. All orbits will at times cross the equator, so they have to avoid the path of the drive field as it extends out from the Belt. This gives a limited number of useful orbital paths, of which humanity is not going to be the only user. Contact with brand new alien races on other parts of Aethos is likely, and may get off to a hostile start if someone's expensive recon satellite smashes into someone else's and one or both sides consider it a deliberate action.

**The truth?:** If Terrans have a Second Exodus protocol, such preliminary missions would be disguised as military or classified intelligence gathering missions, or maybe even done under civilian cover, some wealthy patriot given a paid commission by the government to do some 'eccentric' exploration that does not involve or bring suspicion on the government. If Conservative Biblists gain control of the government for an extended period, it is almost certain they will implement such a program. It would be a way to funnel government money into the hands of key supporters, and even if it goes against dogma, it will provide an exit strategy if the prophecies turn out to be wrong, allowing the chosen faithful to escape the wrath of the Aeth.

This is a long-term plot thread that will really only come to the fore in the last few decades before Arrival. The most important and dangerous part of this particular space program will be an attempt to find asteroids in the system as temporary bases on which to build fission and fusion warheads and rocket engines, since these cannot be built on Aethos itself without drawing the attention of the Aeth. Use of such devices on or near Aethos would probably be a bad thing for the race doing so...

### **Campaign effects**

As a scenario, this is very long term, and can be a background plot that surfaces occasionally and then sinks out of sight again. Earth almost certainly has an Exodus plan. Our ability to generate speculative projects, especially fiction, is a significant commodity. Most popular Terran publishers insist on a pre-release clause that lets them sell one advance copy to an Ancient collector a few months before general release, and for notable authors the proceeds from this one sale can be a significant percentage of their total revenue. Novels about and fake spaceship plans for Exodus ships rise and fall in popularity like *Enterprise* blueprints for *Star Trek* fans.



But in terms of Exodus plans, those are no doubt *very* secret, and unlikely to be available except as fragments of rumor in a sea of rumor. But given the time such plans would take, they are probably being acted on to some extent at the very start of a campaign. Because of the population density, a project like this simply cannot be hidden somewhere out of sight. There is going to be too much hardware involved to make it happen somewhere that is *not* close to major manufacturing centers. There will be too many manufactured components to keep them from piling up somewhere. Somewhere there are a one or more secret government warehouses with finished habitat cylinders, maneuvering engines, re-entry modules and things that clearly have no *current* use.

Another thing that will happen is that new construction will be disguised as something else, something plausible, but which can be quickly repurposed. A new airport capable of handling increased suborbital traffic. A manufacturing plant for particular components that can make far more than any commercial demand for them. Stockpiling of certain strategic metals that is only noticeable as a gradual increase in price due to scarcity.

Later on, construction on things really has to ramp up. Once Aethos has slowed down enough to make it practical, an Exodus program will need to launch unmanned probes, and possibly manned scout ships. Very long range comm arrays will need to be set up in the far north, and eventually, the far south. If there are technological inhabitants of this system, they need to be contacted, warned and possibly negotiated with. New languages have to be deciphered, alien audio and video and data protocols figured out.

Eventually, in the last decade or two, the big and expensive decision to assemble and equip the colony ships has to be made, something that will take much of Earth's industrial and economic output. Keeping a strong military to keep the Cartoo at bay will take even more resources, and all of this will be to give just a tiny fraction of one percent of Earth a chance in this new system.

A possible complication or twist to the whole Exodus deal is lurking in Aethos' wake. The Martian ship *Burroughs* was launched in the final years of the Martian colony after the Aeth departed, once it became clear that the colony was going to fail. Accelerating to catch Aethos using a fusion-based Orion drive, it decelerated to pace the planet at a safe distance, using Aethos' massive bulk to protect its fragile structure from relativistic dust and debris. For the past several centuries it has maintained course and position, its hibernating crew taking several month duty rotations each 20 years of sleep. Since only a fraction of the crew is needed to operate and maintain the *Burroughs*, the rotating maintenance crew will only age about a decade and those staying in cryogenic suspension will not age at all.

The distance *Burroughs* has kept from Aethos, the general noise of relativistic travel and the lack of human observation stations on the south pole means that no one really knows *Burroughs* is there. *Burroughs* has been keeping quiet and listening, hoping to find human transmitters it can make contact with, but none have yet appeared. However, once Aethos slows down, the noise drops and Earth launches its first satellites, this will change. Both the cryostasis tech of the *Burroughs* and the fact that it has a working fusion drive are factors that could be vital to the Exodus, provided the *Burroughs* keeps a safe distance from Aethos. The *Burroughs* is designed so it can completely shed all nuclear tech and glide to a landing on Aethos, but if there is an Exodus, this fusion drive would be a godsend for the colony ship.



This can lead to problems both on and off Aethos. The Terran government will want to keep *Burroughs* a secret, and since they have control over satellite communications, this should be easy to enforce. However, *Burroughs* might not *want* to be kept secret, and it can easily maneuver to where it is in reach of any number of Terran ground receivers. Earth can *claim* authority over the *Burroughs'* crew, but the *Burroughs'* crew has zero loyalty to Earth.

The population of Earth would be overjoyed to learn of survivors from the Old Earth come to join them. They will be less than overjoyed to find that the government has been lying to them for the past nine centuries and that not only was the Old Earth destroyed, the humans on Aethos (and *Burroughs*) are the only humans left *anywhere*.

How this might play out is anyone's guess, and depends a lot on which factions are in charge of the government at that time. If this revelation were to happen around an election year, it would certainly devastate the party in power (since they would be caught actively maintaining the lie at that time). It is not beyond Terran political cunning to have one faction know about *Burroughs* as an internal secret, and arrange to look ethically 'clean' about the time any embarrassing information comes out, thus assuring themselves of victory under an 'open government/no secrets' platform. Which they will of course take their own sweet time in implementing after they win, if they bother to do so at all. *After all, the final pre-Exodus years will be very chaotic and a strong government hand may be necessary until things settle down a bit...*

## Forbidden Customs

Customs are by their nature, public. It is a formalized representation of some of your beliefs. However, not *all* things that are believed to be Customs of Old Earth are legal or socially accepted. These customs are *not* recognized by law and grant no specific legal rights or privileges, but there are groups of people who practice and put great importance on these Customs nonetheless. Like legal Customs, they have certain required codes of behavior and grant certain rights, but *only* among those who also follow the Custom or utilize the Custom. An Old Earth example might be a Mafia 'code of silence'. You do not rat out your fellows, and people will make sure you are fairly treated in jail and that your family is taken care of. Or, if you hire a professional assassin, there may be a certain Custom associated with it, some unwritten rules about what to expect. These forbidden Customs are also a security feature. If you do not know the ins and outs of a forbidden Custom, you are likely to trip up and reveal yourself as an outsider. Those involved in these illegal Customs may give subtle conversational tests with those they are unsure of, just to see if they are dealing with someone who is posing as something they are not. Between those with *known* reputations (like any form of Status in that sub-culture), this is unnecessary.

**i** A person dealing with an unknown assassin might ask 'And I want his entire family killed.', knowing that a *real* assassin doesn't kill children, and if the 'assassin' agrees to do it, then they are an amateur and not to be trusted. Similarly, if a known assassin is approached by an unknown person, they might offer to kill the target's entire family for a minor increase in fee, knowing that if the potential employer considers the offer, then they have never dealt with a real assassin before and are not to be trusted. Between an organized crime figure and a *real* assassin, this sort of testing is unnecessary.

**The truth?:** There are all sorts of forbidden Customs, most of which have to do with organized criminal activity or frowned upon things like pedophilia or serial killings. If you have skills and a background that would skirt the edges of a forbidden Custom, you may know a little of it, but unless *you* have hired someone or *are* someone with that Custom, you do not know the full details. If you have a Friend within that Custom, you would know someone who could give you those details if you asked ("Uncle, I need to hire someone to take care of a problem..."). Usually, it requires an Unusual Background to have a useful knowledge of a forbidden Custom.

If you want to get an idea of what Earth's forbidden Customs might be, you simply look at what is permitted (which is quite a bit), and then imagine cultural elements of Old Earth that stray outside these libertine boundaries. The previously mentioned Mafia code would be an example. You are choosing to deliberately make yourself an accessory to crime by not reporting it, you follow orders to commit certain crimes, and so on.

### Campaign effects

This is *not* a scenario, but does have elements that can be incorporated into one. Adventurers are unlikely to know about or even believe in forbidden Customs at the start of a campaign unless they have the aforementioned Unusual Background, and if they do, then it is something that they do *not* talk to other people about anyway. *Not even friends or family, if they are outside the Custom.* While players frequently share information that adventurers keep compartmented, a forbidden Custom should at least start play as a *player* secret. Something where a *player* has to say "I can't tell you about that". This adds to the mystery and suspicion that comes with a forbidden Custom. Now, note that a forbidden Custom does not *have* to be secret. There are plenty of 'legitimate businessmen' out there who have a forbidden Custom. They just have not been *caught* in the act of *using* it.

### Harvester

One theory about the Aeth that has some credibility among Arkivists and a handful of others is the 'harvester theory'. In a universe that apparently does not have faster-than-light travel, it seems odd that every surface race on Aethos shares the fundamentals of DNA and about the same temperature, gas and gravity regime. There are a few thoughts on the matter. One is that the Aeth only aim for worlds that meet a certain set of criteria, and that DNA is molecularly speaking, the easiest way for life to self-assemble, and thus happens spontaneously on different worlds. The 'harvester theory' says that someone or something seeded at least this part of the galaxy with the earliest stages of DNA-based life, somewhere between five hundred million and one billion years ago, and the Aeth are simply reaping the results of that seeding.

As best anyone can tell, Aethos is *not* a billion years old, possibly not even a million years old (the oldest known transplanted terrains show less than a million years of weathering). This means that the Aeth are merely collecting the results of an even older and possibly more powerful race's work, or that the life they collect is merely a side effect, and they are actually searching for something this older race left behind, and scouring and sorting through the top several kilometers of a planet's entire crust is the only way to find it. As always, guessing about the motivations of the Aeth is just that, *guessing*.



**The truth?** - No one has yet done an exhaustive comparison of the DNA of the various races and species on Aethos. Those who follow a theory of intelligent design and do such a check might be able to find a 'maker's mark', chunks of junk DNA that are identical across species from different planets, and which have embedded information content. Whether or not this information content is a message, merely some ancient alien signature, or a key to something useful and incredibly important is anyone's guess. It is worth noting that if humans are able to find it, the Aeth already have, so any significance it has to *them* has already been acted on. The mark might be how they identify biospheres which they collect from and which they merely strip mine. On the other hand, the mark might be something the Aeth put *into* the DNA of whatever they collect. Determining this would require access to samples of DNA from things the Aeth have not collected, which falls within the scope of some of the other plot ideas and scenarios.

Since the Aeth operate at sublight speed and clearly make plans on the scale of thousands of years, it is possible they are acting on information and humans simply are not aware of it. To add a little more importance to it, perhaps the system Aethos is approaching is of significance in this regard. Maybe the Aeth are arriving back 'home', or are finally going to meet the designers of that ancient DNA?

### **Campaign effects**

This is *not* a scenario, but it has philosophical and scientific implications that can filter into politics. The notion that humans share a 'makers mark' with aliens might not sit too well in some circles. On the other hand, such a mark might lead to certain other discoveries of commonality, ones that could have economic applications. Or maybe even military ones.

## **The Big Brain**

Sporadic emissions from inside Aethos interfere with ultrahigh density electronics and also interfere with other quantum-level phenomenon. Higher level devices can still be made and *will* work, just not reliably (unpredictable system crashes). This makes ultra-sophisticated computers no less possible, just bulky and power-hungry. The maximum information density and computing power that the surface races can sustain is about the same as the early 21st century on Earth. Top-level government researchers among many surface races have built massive computer arrays and programmed them for the sole purpose of trying to fathom and predict the actions of the Aeth. Every incident involving the Aeth, every sighting, every ship launch, trajectories, patterns of movement, known communications and so on, are all programmed in, in the hopes that a computer can make sense of what human minds cannot.

This is useful, within its limits. Those limits are that these computers are designed and programmed by beings incapable of understanding the Aeth, so their programming and methodology is going to be fundamentally flawed. Imagine you live in a two-dimensional world and you are trying to predict the motion and appearance of an unknown force, without being able to understand, describe or program the fact that this unknown force operates in three dimensions, not the two that you are able to understand. Now, Aeth are *not* four-dimensional, any more than we are, but the analogy holds. Any computer designed to understand the Aeth must be flexible enough to adjust its own programming beyond levels that make sense to humans. Once it does, it can grasp some of the 'why' about the Aeth, but then it cannot convey this back to its mentally limited creators. All it can do is generate results and predictions that are more accurate than most, and people will just have to trust it. Whether or not a computer complex enough to begin to understand the Aeth will automatically become self-aware is a matter left to the gamemaster.



! The ramifications of 'giant computer becomes self-aware' are a plot unto themselves, and are not dealt with here, but remember that it does not have to be a *Terran* computer that does this...

**The truth?:** Plotwise, what has happened is this: A Terran collector and broker in relics from extinct races was found dead. Not only was it not by natural causes, but the poor fellow appears to have been tortured for several hours first and his records were ransacked. One of his most recent acquisitions and resales was an ornate cylinder about the size of an oil drum, of Thernic origin. Inert and of unknown function. However, a recent translation of an old Thernic data tablet indicates that such devices were used for mass storage, and that one of this size would hold an amazing amount of data. Government investigators discovered just enough about the provenance of this object to infer that it was shipped out of Thernic territory just before their extinction, and the theory is that someone among the Thernic wanted to hedge their bets in case something happened to their civilization.

At this point, the Thernic relic becomes a *big* matter of national security. The Terran government would dearly love to have the information that this relic might hold. So would every other species with a Big Brain, and the Ancients would pay an inordinate amount for either the object or its data. It is clear that whoever killed the antiquities dealer knows something about it, and from what can be pieced together of the buyer shows that they knew something as well (a shell company with a rented and now-abandoned address). The whereabouts of the relic are not known, but Terran borders are being quietly tightened and any object crossing the border that is large enough to match the description is being dismantled or scanned down to a level where conventional smuggling would be impossible.

Not knowing any of this, adventurers might be contacted to transport an item across international borders without being detected. This would make them the fall guys if caught, since their employer would be a cut-out who could not be traced. However, this employer obviously wants the adventurers to succeed. Another option is that the adventurers are merely a decoy, and the item they are transporting is merely a fake or even just a chunk of weight in a crate. If they succeed, they will find any payment due on delivery is not forthcoming. On the other hand, if they are caught, they are only guilty of a smuggling attempt rather than an espionage charge, and they might be able to wriggle out of the smuggling charge if they agree to help the government track down the people behind the operation.

### Campaign effects

How this can affect a campaign in the long run really depends on *what* is in the artifact. Until someone finds a way to access, decode or otherwise recover the data, it is priceless. Once the contents are known, it could be even more priceless. *Or it could be worthless.* What might be in the artifact's datastore of great value? It might be maps of Aethos' internal structure. It might be plans for advanced non-nuclear propulsion systems. It might be a new form of energy conversion for weapons., Or it might contain information of what the Thernic planned to do to the Aeth. This last case would be the most valuable and the most dangerous. After all, *acting* on this information rendered the Thernic extinct, and information of this type is something those following Apocalyptic Biblist beliefs *would* try to act on if they had it. And some members of this Custom could be running for offices high enough to have this information be within their security clearance...



## Espionage

There is an extra level of difficulty in spying on a race other than your own. It is kind of hard to blend in when you are a *different species*, and the most sensitive information a race has is simply not going to be accessible to anyone outside that race. It is even harder when you are in a perpetual state of near-war, like Cartoo and Earth are (actually, the Cartoo and just about everyone they meet). So, covert intelligence gathering is usually done through proxies, bribed or blackmailed or simply convinced that it is the right thing to do. Each race has their own particular buttons that can be pushed. Terrans *can* be manipulated into working for the Cartoo and vice versa (yes, the TSO has Cartoo spying on other Cartoo and these Cartoo know they are doing it for the TSO). The same can be said for any other race. It is virtually certain that even our allies the Drinn and Tuaqq try to gain information about Terran secrets, and Terrans certainly try to do it to them. It is *quite* scandalous when someone is caught at it, but the end result is usually nothing more than bluster, because everyone knows that everyone else is doing it. And the spies are just pawns, and pawns are meant to be sacrificed. *Which is just a note to players in case the gamemaster tries to get them into that role...*

Espionage is not always done at a government level. There is ongoing industrial espionage and economic espionage. They are interrelated, but industrial espionage is usually more about getting trade secrets, manufacturing processes and other proprietary information, while economic espionage is more about influencing markets, and altering commodity prices or exchanges rates for the purpose of profiting off them. Economic and industrial espionage are usually illegal to have done in your nation or to your industry, but it may not be illegal by your race's laws to do them to some other race. And some of these efforts can be extremely byzantine in their complexity.

**The truth?:** It is illegal under Earth law for a non-Terran entity or business to have more than a fifty percent ownership stake in any Earth real estate. Most other races have similar laws, with varying percentages of 'foreign' investment allowed. In Philadelphia, a significant number of the low-rent housing complexes are owned by a corporation with a slim human majority ownership, and one wealthy family with a good share of that majority. The other stockholders are Tuaqq and Drinn, with a small amount of Cartoo holdings from a major Cartoo investment concern. The trick is that the Cartoo are almost the majority investors in the Tuaqq and Drinn concerns. All it would take is a little bit of bribery, blackmail or extortion on each of the Tuaqq, Drinn and Human concerns for the Cartoo to swing overall decisions any way they want.

Like most major Earth cities, Philadelphia is crowded. Not '21st century Tokyo' crowded, nor as stratified and slum-ridden as Old Earth's Rio de Janiero, but nonetheless it is a crowded place where many folks are barely getting by. No one is starving and no one is living on the streets unless they want to, but living at a near-dole level with little chance of upward mobility for yourself or your children creates undercurrents of discontent and resentment. It is an election year for Earth, and an Arrival has begun, adding social pressure to the system. If the Cartoo were manipulate the situation to adjust rents upwards for many people by just enough to cause some social instability, they could probably find one or more ways to take advantage of the situation. First of course, they would financially profit. Second, riots could break out and require diversion of police or military forces. Third, they could use the ill feeling to help a specific faction gain a Legislaat seat and help or harm specific Customs that might be linked to the situation. Intellectual Capitalists would probably fall in popularity, while SocioPopulists would probably gain.



Last, inciting riots might be used as a cover for some other operation that could only be shielded from view by mass chaos. For instance, a politically influential Cartoo fleeing home in a private jet and ignoring border checks on the assumption that the consequences of shooting him down outweigh the consequences of letting him go. What else might be aboard that jet is anyone's guess (Thernic relics, anyone?).

### Campaign effects

Espionage of various kinds is going to be a central part of any **Aethos** campaign. The government *will* be spying on people, people *will* be spying on the government, races *will* be trying to spy on each other, business allies and competitors will spy on each other and so on. Much like Old Earth, except with aliens. Players should look at their current real-world situation for parallels. If they were to come under suspicion, virtually anything and everything they do could come under official scrutiny. Challenge a *player* in any sort of urban environment to spend a single day of their normal life without showing up on:

- traffic cameras (sometimes at every stoplight)
- security cameras (street, bank, store, etc.)
- internet logs (cookies, etc.)
- cell phone logs (if a phone is on, it is traceable)

We sort of ignore this in our daily lives, but it is there nonetheless. Avoiding having the all-seeing-eye focused on you is a lot easier than avoiding it once it is looking for you. This item is set in Philadelphia, which has a high level of government oversight on anything electronic.

The specific plot mentioned is not likely to have any major effects, but it is an example of how espionage can influence other plots. Effects could be as mundane as telling players they have to nick a point off Savings each month just to maintain their Lifestyle, because of increased housing, food or energy costs.

## Kasari Observatory

The Kasari Cosmic Ray Observatory is an obscure research station, based in a played out iron mine in a part of Earth formerly known as Turkey (the state of Ankara).

It was constructed about three centuries ago and has been in near-continuous operation since. It is a pure research facility, built by the government to take advantage of the calm of interstellar space to do astronomical studies of high-energy particles from Aethos' suns and other sources. The number of researchers authorized to conduct experiments is fairly small, but once the initial build-out was done in the mine, the operating cost was also fairly low.

The reason this is a place of interest is that it is more than it seems. Humans have an inherent curiosity and hate limits placed on them, and the Aeth trigger both of these. The Kasari Observatory is, in addition to a cosmic ray observatory, a gravity wave and neutrino detector. The suns are sources of both, and their regular path lets the facility very slowly generate a map of the inside of Aethos. Scarth does not stop neutrinos or gravity waves, but it does interact in known ways that are quite different than an equivalent amount of normal matter. Over the past three centuries a fuzzy but usable map of Aethos' interior structure has emerged. The depth of the map varies with the distance from the observatory and the resolution is abysmally poor, but it does seem to confirm other observations of the layered nature of Aethos, down to at least several hundred kilometers. Plans for secondary facilities are underway, using deep boreholes in a circular pattern around the main detector to hopefully improve resolution.





While the Kasari Observatory does do *some* real science with civilian researchers as its cover, all of the sensors and data relating to subsurface mapping are highly classified. It is not known if any other races have undertaken similar efforts, but many of them would pay handsomely for the Kasari data. Similarly, the Terran government would pay very well for data that would verify their maps or give information about unusual subsurface structures. The Terran government has exhausted any lines of information the Ancients have chosen to trade, so any new information must come from *new* sources.

The Kasari Observatory is not much to look at, a cluster of rebuilt administrative offices for the mine, extended to cover the mine entry itself. From there, it is a kilometer-deep elevator ride to the observatory itself. Security is tight, but not very visible. All the entry and ventilation shafts go through the main building, so you cannot sneak in or sneak out. Data is stored underground, and securely archived off-site, transferred there by armored courier and protected by self-destruct devices while in transit. Someone wanting to steal the data would have to want it very bad and be very sophisticated about it, or be highly placed enough to bypass the safeguards and smuggle out a copy.

The civilian researchers know there is a secret aspect to the observatory, and accept oversight and surveillance as part of the price of using the facility, even if they grumble about it a bit. It is the only facility of its type on Earth, so no one does anything to jeopardize their access.

However, someone has *inadvertently* done something that may have later repercussions. All civilian data and research is vetted by the TSO before release, but the TSO is looking at it for security breaches, *not* as scientific data. A recent set of scans has picked up a point neutrino source other than the suns, relatively close and closing from behind. This is the main fusion plant of the *Burroughs*, warming up as full power is needed for habitat, sensors and such. This sharp point source can also be picked out of the background noise from decades of previous observations...if you know exactly what you are looking for. And the recent observations tell you *exactly* what you are looking for, and where.

These readings will precede *Burroughs* active attempts at radio transmission by a few months. The knowledge that a fusion-powered ship, possibly human, has been trailing Aethos for several decades is a major bit of news, and once the TSO realizes the nature of what the neutrino readings are, they will be very keen to try to put that genie back in the bottle. The scientific paper will be withdrawn, the cloud-storage data sets will be subtly altered and the paper's author will issue an embarrassed retraction. However, copies of the data set were downloaded, and a few of the people who did this are competent enough on the subject to see the significance in the real data. TSO pressure, official or unofficial, may create circumstances which can get the adventurers involved. This could be something as simple as a physical delivery that needs to bypass the normal postal or commercial services, or as complex as a borderline paranoid who thinks his 'Government Exposed' web site is being hacked and corrupted (it is) and thinks that the Greys (some obscure Old Earth reference) are beaming subliminal signals into his brain (they are not).



## Hate crime

Investigation of the grisly mass murder of a small commune of Neogians turns up leads and threads to indicate the crime was both based on their faith *and* something else, something the authorities are both pursuing *and* trying to keep secret. It is quite possible the two motives may be unconnected, further muddying the issue.

In a society where virtually everyone knows how to use a gun and a significant percentage of people carry weapons with them (the exact percentage varies with location), murders are not *that* uncommon. Not nearly as many as *players* might expect, but humans are still humans, and violent impulses come to the fore more than we might wish. However, mass murders *are* uncommon. After the Exodus, humanity was forged from disparate parts into a fairly strong 'us' in order to fight off 'them', and that societal cohesion has largely held. For a large group to be killed is unusual, even more so when all of the victims share the same Custom.

*In short, it is big news.*

Far more details on the crime quickly become public than the police would like. For anyone curious, some things are readily known:

- the attack was made during a public forum where most of the community was gathered
- multiple autofire weapons were used
- wounded survivors were executed where they fell

Following the story in depth might dig up:

- some resistance to the attack was mounted. Some of the dead Neogians were holding personal weapons, some had engaged in combat long enough to have reloaded them
- civilian records show that network traffic in the area was offline for about an hour, approximately before the attack took place

Known to the police and a few journalists (now under a government secrecy order):

- an electromagnetic discharge weapon was used, frying all sensitive electronics in the area
- one person left the commune site wounded and being carried. It is unknown if this is a wounded attacker or a visitor to the commune. All the *known* members of the commune were accounted for amongst the dead

**The truth?:** Something *else* is happening, maybe related to the spore incident and the Aeth artifact found in the maneuvering vent by the Neogian refugees. Maybe someone at the Neogian commune in the adjacent polygon learned something, and the only way to make sure the information stayed secret was to make sure there were no survivors. Maybe the person carried off wounded was a visitor who had knowledge someone did not want spread, and the only way to *ensure* this was to eliminate anyone they might have told it to. Maybe the visitor was not even human *nor* were the attackers, and this is something the police have managed to keep from the media. Or maybe the local police have now been shut out of the investigation and it is all behind handled by the TSO.

The authorities *seem* to be conducting a real investigation and not trying to cover anything up, but there is no way to know for sure. Then there is the matter of an anonymous parcel delivered to an adventurer's residence, one day *after* that residence was broken into and ransacked. In the package were two data storage chips, one of human manufacture, one of Tuaqq origin. The contents of each are up to the gamemaster...



### Campaign effects

This can be a background item to be a possible distraction from something really important, or it could be part of or *the* main event for an adventure. If a player has just bought off an Enemy or used up a Favor, this could be how it happens in play. The Favor might have been something Neogians owed the adventurer, or the Favor might have been something from whoever was carried off after the attack. Or, an Enemy may have been operating out of the Neogian community or been the person carried off. In any of these cases the adventurers do not *need* to get involved, but knowing who did this and why would certainly be interesting. One thing for sure is that whoever was behind it has no moral compulsions about covering their tracks with extreme prejudice.

Another way of getting Friends involved is for a Friend of an adventurer to call in a marker and ask the adventurer to investigate the crime. Maybe a victim was a family member of the Friend, maybe the Friend is in the government and one of the Neogians was actually an undercover agent.

The danger of adventurers getting involved in the situation is that whoever the adversary is, they are skilled, organized and ruthless. Unless and until the adventurers get some sort of leverage, they will be in trouble in any sort of direct confrontation. The anonymous package and the unknown data chips might be that leverage. Some keywords or descriptions of images might be enough to turn a potential firefight into a Mexican standoff. Of course, the adversaries might insist on retaining 'custody' of an adventurer or someone adventurers hold dear until the chips can be turned over to them. All the while planning to kill the adventurers afterwards, or even to just covertly follow them home and kill them there, just to make sure the data has not been copied. Or, they might torture their captive to find out who has been told anything and how much, and then kill the remainder of the adventurers after delivery.

*Clearly, the unnamed adversaries are bad news.* How and *why* they are bad news needs to tie into some other plot, and this will give who they are and the exact nature of their organization, numbers and training.

**Possibilities:** The spores from the Orb in the **Squatter** scenario grant anyone affected the ability to 'see' the parasitic infection in the **Aliens** subcase of the **Bats over Barstow** scenario. The adversaries are the hidden aliens, who have already completely infiltrated some select military units and some positions of authority.

Another possibility is some sort of Cartoo infiltration unit, sent to capture a prisoner or possible asylum-seeker who made it into Terran territory. Normally, their presence on this side of the border would be provocative, but not beyond the normal level of Cartoo audacity. The mass murder and clear attempt to cover their tracks indicates a motive *other* than causing outrage. This might tie into the Thernic relic in the **Big Brain** scenario.

A third possibility might be that some human political faction that is currently out of power has some secret knowledge, highly illegal plans or both, and that somehow, someone in this Neogian group stumbled onto it. If it were something the current government was up to, the TSO could come in with their heavy-handed intimidation tactics and probably keep it squashed. But a group that is outside of government power does not have that option. Knowledge of the *EDF Tiberius* might fall into this category (from the **Ghost Ship** plot). Potentially, knowledge of the *Burroughs* could also qualify (from the **Second Exodus** plot).



## Temple of Dhuum

Archaeology on Aethos is mostly a for-profit enterprise. What remains of humanity's past has mostly been recovered, though isolated pockets of new knowledge and artifacts of value are occasionally recovered from the warrens dug beneath some of the rubble of Old Earth cities that the Aeth transplanted, or from rural structures found by accident or through following clues found elsewhere. However, the bulk of human archaeology is trying to recover knowledge and artifacts from the ruins of extinct surface races, and these things have value beyond the academic. Archaeology on Aethos is much closer to treasure hunting or late 19th century archaeology than it is to the 21st century expression of the science. And this approach is not unique to humanity.

*The possible scenario is this:* Human and alien archaeologists are investigating the same set of deserted ruins far from the home territory of either. Calamities of an engineered nature befall both groups, each of which blames the other. Both sides are armed, though not heavily so, increasing the tension, exacerbated by only a partial ability to communicate. Both sides have translation modules for a language neither side has native speakers of, much like an American and a Korean trying to communicate by using an American-Russian and a Russian-Korean dictionary. In practical terms, the effective language skill roll is 1d+0 for anything except archaeology and implementing it is slow. *Anything of a non-archaeological nature is conveyed in sentences composed only of single syllable words.*

**The truth?:** There could be a several different reasons for what is going on. The problems each side is having might have been internal to that side, but had coincidentally bad timing. The human side might have a human mole who is being paid by a rival investor to sabotage their own expedition somehow, and the alien side has something similar. Each side's saboteur sees the advantage in blaming the other side for the problem.

Or, there is a race of primitive nomads who wander around this part of Aethos and whom are being used by both sides as day laborers for digging and other tasks. The nomads are secretly xenophobic. Smart enough to realize that directly antagonizing a more powerful race is going to be trouble in the long run, they hide their emotions towards outsiders, and have plotted to turn both sets of alien invaders against each other.

Or maybe there is a third, secretive race that found out about this site from its own sources. Its only representatives here are some high-tech scouts who use advanced tech or biology to stay virtually invisible, and they are trying to get both sides to leave before their own team gets here and lays claim to the entire site.

## Campaign effects

This is a simple standalone scenario idea that does not have to link to any larger or long-term background theme. Adventurers could be merely passing by this location on their way to or from somewhere else and get caught up in it by accident, or because an incident while they are there involves or perhaps implicates one of the adventurers or other members of their group. It *does* take place in a different, distant polygon, so it does require some sort of business outside Earth's jurisdiction and which cannot be flown to. If adventurers have any sort of patron, an excuse might be that the patron has an interest in the dig, is on-site and wants to speak to the adventurers, so they have to come to him or her. And the scenario unfolds in addition to whatever reason the players were summoned there.



## Caveat emptor

The Cartoo are in Terran terms, one big criminal empire, though of course the Cartoo do not see it that way. Crime is far from unique to the Cartoo. Other races have their own versions, and many things Terrans consider criminal are normal practice elsewhere, and vice versa. However, there are overlaps and Cartoo theft goes very well with Terran insurance fraud and extortion.

Terran businesses that need to deal on the Cartoo side of the border often will charter or rent vehicles for the trip. This is usually a fairly safe proposition, though rental or charter outfits charge about double the normal rates for cross-border work, because the risk is higher. A few enterprising outfits have cut deals with a particular Cartoo concern in their border area. If they get a rental or charter query that matches certain parameters, it means the renters are probably new at this sort of thing, and not particularly well-funded or well-connected.

If the Terran side identifies a potential mark, they alert their Cartoo confederates, who will then ambush the renters somewhere on the Cartoo side, conveniently allowing them to escape on foot after immobilizing the vehicle with gunfire.

The vehicle, which was actually immobilized by remote control coincident with the gunfire, is marked off as lost by the Terran side, soaking the renters for the full cost because of their negligence. After the renters are soaked for the full replacement cost of the vehicle, the intact or mildly bullet-dinged vehicle is returned by the Cartoo to do it again to some future victims. The Cartoo get a cut of the proceeds and any goods left behind by the fleeing renters as their payment for possibly getting shot at.

This is easily the sort of scam adventurers could end up on the wrong end of. The difference is that adventurers are likely to be better skilled, have tricks up their sleeves and be far less likely to cut and run, especially if they think something shady is going on.

This particular set of events could involve the adventurers in a number of ways. They could be the potential victims and end up in a fire-fight, stuck on foot in Cartoo territory while a bunch of unhappy Cartoo want some payback for the insult of being shot at while trying to rob the adventurers.

Or, they might be hired by the previous set of victims, who after thinking about how events transpired, have become suspicious enough to want the matter looked into.

Or, among the things left behind in the vehicle was some sort of prototype device the victims were working on for the Terran military, which makes it a quasi-diplomatic problem. But you cannot just go to the Cartoo and say "can you please return our fancy gadget with potential military applications?". Someone has to go in and get it, and what better way to do so than to arrange to get ambushed by the same people who took it?

## Campaign effects

This is a simple standalone scenario idea that does not have to link to any larger or long-term backstory. It is a possible bridge between other adventures or a way to introduce the adventurers to a possible patron or get them noticed by people the gamemaster needs an excuse to get them noticed by.



## Bats over Barstow

A few centuries ago, Earth sent a massive, self-mobile resource extraction rig up to the northern ablation shield. The purpose was to mine the debris at the fringes for useful elements and scarth powder. It was a huge, slow, solar-powered town on treads. It cost a fortune, took two years to get there, operated for about nine months and then had an irreversible breakdown. The exocaps used for energy storage overloaded due to some sort of emanation from within Aethos (not a deliberate action as far as anyone can tell). Safety measures prevented *catastrophic* damage, but the exocaps, thousands of tons of them, were ruined, and power surges fried many key systems. The rig was designed to be able to manufacture many of its own spare parts, but nothing on this scale. Unable to move, smelt and maintain a livable atmosphere, and with no investors willing to put cash into repairs that might be undone by another random emanation, it was evacuated except for a skeleton crew using the trickle of remaining power to keep a portion of the rig with a livable environment. The corporation formed for the expedition was dissolved several years later and the last of the caretakers was evacuated around that time.

Since then, the rig has been used as a platform to mount science instruments on, an exploration destination for the daring, at least three alien visits (one by the Cartoo) and a colony for a quasi-apocalyptic cult. The bare minimum of the rig is made with steel or other metals, but this is *still* some tens of thousands of tons. It is worth a fortune, but not by the time you bring in the massive machinery necessary to dismantle it into transportable pieces.

However, there is a venture capital operation being funded for the purpose of repowering the rig and driving it back to Earth so that it can be dismantled *here*. The idea is to land a few cargo planes on the bare scarth, transport just enough new exocaps to even out power irregularities and then start *slowly* driving it south. The cold, dry conditions of the far north mean that very little decay has happened, and if all the mechanical parts are relubricated, the Bats over Barstow *should* be able to creak and lumber its way to warmer climes where it can be profitably scrapped.

The first stage is getting an engineering crew on board to determine if enough systems are still operational to make this work. This is where the adventurers come in. There are a number of hooks to get adventurers of differing skills onto this expedition:

**guards:** It is well outside of Earth's zone of influence. The closest place to land a cold-adapted cargo plane is only a day away from the *Bats* by scarthrunner, but because the terrain is covered in debris to various depths, it is actually a few days by tracked crawler. Security forces will probably make up half the expedition, just to be safe. This is a reasonable entry to the scenario for military veterans.

**patron:** Any of the investors in the project can designate a few of their own specialists to be part of the expedition. If the adventurers have a powerful Friend, this could be something that the Friend asks for.

**media:** It is reasonably big news in some circles. Enough so that at least one media representative and possibly a cameraman and bodyguard can pay to accompany the exploration team and acquire documentary footage.



**government:** As Arrival approaches, the rig could be a strategic metals resource and the government has the option of buying out the investors and taking over the project. The government would rather the risk be taken by private entities, but if the investors decide it is not viable and the government thinks it is, a buyout is possible. The government representative will be qualified to evaluate the situation. The government might contract part of this to an adventurer who has a particular expertise applicable to the situation.

**corporate:** The legalities involving the original corporation might allow anyone who still has a financial stake to be represented. For instance, to recover personal property of a long-dead family member.

### Background

The extraction rig was named the *Bats over Barstow*, a name somehow associated with the nearly extinct Gonzo custom, and chosen by a popular vote that was some decades later shown to have been manipulated by a group of Gonzo Anarchists for reasons that have remained unknown. *This is unrelated to any plots involving the rig.* While it was being used and by most who refer to it, the rig is just 'Bats' or 'the Bats'.

Bats is a very large, somewhat flexible steel and composite chassis to which a mining rig, refinery and town has been attached. Bats is large enough that it has to be flexible in order to not break into pieces when moving over undulations in terrain, and is approximately a hundred meters wide, a hundred meters tall and about a kilometer long. If you think of it as an a large aircraft carrier on dozens of massive treads you would be about right, except a lot more lumpy. It is, without doubt, the largest self-mobile item the adventurers have ever seen. The superstructure of *Bats* is made from industrial composites with occasional ceramics, and the upper surface is array after array of solar collectors, both for electricity, heat and light.

Most of the electrical generation is still intact and will be used to power the refurbished *Bats*, it just needs enough new exocaps to balance the loads and provide surge capability for starting the motors. Electrical distribution throughout *Bats* is spotty. Time and squatters have messed things up a bit. Areas used for habitation have good power. Some areas are completely without power, wiring or other components scavenged to repair different areas.

The heat transfer system is mostly borked. Relying on pumps and fluid transfers, most of the working parts are gummed up by now. Limited areas may still be in service, but in general, the temperature inside *Bats* is at least -20°C, colder in the core, higher near the surface where wan sunlight hits it. Any skill involving manual dexterity needs to be doable in gloves, probably at a -1d penalty, and the gamemaster should make sure adventurers check Encumbrance due to the weight of insulated boots and clothing needed for any excursion outside the very limited habitable zones. Even without armor or weapons, everyone is almost certainly taking at least a -1 encumbrance penalty. Taking off gloves to avoid a dexterity penalty in a long fight almost guarantees frostbite and lost hits from tearing off skin when you brush it against something supercold.

Light transfer was by fiber-optic arrays and is still mostly functional, so even the core of *Bats* has usable illumination, with electric lights available in areas that still have power.

There was no way to strip *Bats* of all its massive support gear, so most of it is still in place. There are trackhoes and such in the ore storage bins, electric delivery carts, recon crawlers and such. Squatters may have used or used up many of the lighter vehicles, or ruined them with impromptu demolition derbies or corridor races, but odds are that *something* working or repairable remains.



Most of the stored foodstuffs were consumed by the skeleton crew and the remainder by squatters, so very little of that is left and would require so much searching as to hardly be worth the effort. The air is exceptionally dry, but there are enough temperature and humidity variations throughout *Bats* that ice has formed in numerous areas and can be broken off and brought back to warmer zones for use. Some areas key to the plot may be completely iced up, resulting in delays in which other plot elements can happen.

The internal communications network of *Bats* was managed by computer, so until at least one of the backup computers is made operational (the main CPU is mostly shot), only radios can be used. These will work everywhere except for communications in or out of the lowermost levels, where the steel chassis tends to degrade signal quality. What remains of the internal computer network is sufficient to monitor the engines and power, provide passable diagnostics on other systems, and access the communication network for areas that still have power. Security camera feeds are unavailable since no one has the codes to access that system anymore. However, comm terminals *can* be turned on manually and their built-in cameras left on to provide limited surveillance of an area. This would have to be manually monitored, since motion-based alerts and recording would be part of the security suite. A clever person *could* set their *personal* comm to monitor a monitor, send an alert if motion is detected, or record what it sees. This would require a hard(11) programming roll in fifteen minutes, but it could be done with an unskilled default, given the capability and number of smart-phone apps among the expedition crew. Having to rely on just one or two phones as potential app resources to draw from would require programming skill rather than an unskilled default.

## Complications

*Of course things will not go smoothly.* It is just a question of when they go wrong and in what way.

**aliens:** Aethos is cluttered with them, and even after a thousand years we still do not know about all of them. Even worse, this is a type that no one knows about. A sublight ship encountered Aethos about a century ago. It was either disabled and crash-landed, or chose to land for unknown reasons. Its crew was technically a bipedal race with superficial similarities to humans, but was practically speaking, crewed by the parasitic intelligences that used this race as hosts. Far from home, far from food, far from hosts, the survivors trekked across the debris-littered scarth until they found the *Bats*. There, they abandoned their worn-out host bodies and went into hibernation, waiting and hoping some other sentience would come along and stir them from their torpor.

The resulting scenario is somewhere between *Aliens*, *Invasion of the Body Snatchers* and *The Thing*. Some member of the exploration team stumbles across a hibernating alien, is infested and controlled, and then seeks to bring others into proximity to its kind so that they can all be converted. And then, to hopefully be retrieved and delivered to warmer climes, there to hide and slowly multiply. They are not an exponential menace to humanity, they simply do not breed that quickly. But they are intelligent and have been doing this sort of thing for a *long* time. If undetected, they could be a major force in human politics a few decades from now.





So, the situation could run two ways. First, no one spots them and they blend in once they return to Earth, there to cause problems much later on. Perhaps a friend or relative of one of the infected explorers gets suspicious, relays this suspicion and then dies under mysterious circumstances. Perhaps afterwards, the uninfected survivors start dying mysterious deaths as the aliens decide to cover their tracks.

The other way it could run is if the aliens get detected early, or their presence is suspected. One open alien pod is found and the others found are still closed. Someone goes missing and then is found, with a plausible but slightly off excuse for their absence. Someone's skills or memory seems slightly sub-par. Key medical equipment that might provide a ready diagnostic is subtly sabotaged in a non-repairable fashion. People become suspicious of each other, and the aliens foster even more suspicion to delay the humans while the aliens make plans to kill them and escape in the surface crawler that brought them there.

Compared to the human nervous system the aliens are compatible, but...alien. It takes them a few hours to figure out how to properly work a human body. It takes a few more to access basic language centers and reflexes, and days to weeks to access skills and deep memories. Even so, they will never be able to use the full skills of a host and will be at -1d on all the host's previous skill rolls. This will be what can give them away, and will be explained as a "knock on the head", "I'm coming down with some sort of bug" or other plausible excuse. Just to keep it interesting, someone with access to security codes or heavier-than-normal firepower should have something like this as a *legitimate* excuse, just to place them under suspicion and confuse the issue.

If you decide to run this as a scenario, you should definitely rent at least one of the movies listed. *The Thing* (1982) takes place at an Antarctic research station and is probably the best one for inspirational purposes.

**revisionist:** An annoying thing about human history on Aethos is that a lot of it is *wrong*. The history of the *Bats* is a prime example. While the damage done to *Bats* is largely as described, the reason for the damage is not.

The consortium investing in the original project had a minority partner who sold their stock short just before the disaster. This raised suspicion, but naturally enough, they had a perfectly legitimate reason for their actions and no charges were ever filed as a result of the investigation.

However, what did transpire is that the minority investor, with the help of some Cartoo infowar specialists, altered the *Bats'* computer code so that it overcharged the crawler's exocaps and simultaneously deactivated the protocols to prevent this. Completely by accident, the saboteur was blown up by an exploding console. The scam was designed to be non-lethal, but the death of the saboteur (and several others) meant those planning it were now accessories to murder. They kept the crime hidden away and the Cartoo kept quiet as well, not wanting to start a major international ruckus...at that time.

Fast forward to a few centuries later. The minority stockholder, having made a neat little fortune off the scam, invested it wisely and is now a multi-billion dollar concern of some venerability and respectability, much like a noble family descended from an embarrassingly common warlord.



When news gets out that the *Bats* is to be brought back for scrap, someone, somewhere realizes that this means the old computers still have to be operational, and that data historians will be going over its cores with a fine-toothed comb. And since there is no statute of limitations for murder on Earth and corporate boards are criminally liable for actions of their corporation, there exists a *slim* chance that current board members could be indicted as accessories after the fact for a centuries-old murder. *That is very unlikely, however.* What is *more* likely is punitive fines in the tens of billions of Euros, for the original ill-gotten gains, interest *and* reparations to those damaged by the original fraud. The company would survive it, but it would savage its bottom line for decades, at a time when economic flexibility is going to be extremely important.

In addition, the Cartoo and their damnably long memories have surfaced and left hints that they would be more than happy to leak information about this corporation's culpability unless they are paid off with some hush money.

So, the decision is made to *re-sabotage Bats*, using a third-party cutout as a minority investor (again). But this time the goal is to *permanently* disable *Bats*. Newer exocaps are less vulnerable to the tactics used the first time around, but the original autopilot is vulnerable from a software standpoint, and the traction engines are potentially vulnerable from a hardware standpoint. There are numerous physical hazards on the long trip back. Simply getting *Bats* stuck in a river or jammed in a cleft would be sufficient. The hardware is a little harder. Each of the traction engines is the size of a small warehouse, and *Bats* has dozens of them. Several of them on one side would have to be disabled to keep *Bats* from maneuvering properly.

The saboteur or saboteurs will not have the tons of explosives needed for wholesale wrecking of the engines, but a stealthy plane could airdrop a parcel of shaped charges onto *Bats* upper deck prior to the exploration team's arrival. A few shaped charges would be sufficient to char up the motor windings, which is not readily repairable. This sort of sabotage will be obvious in its nature and intent, but subtlety is not the intent this time.

The saboteurs know the legal penalties for what they are doing, and are not above a spot of murder to cover up their actions. Neither is the corporation that hired them, since they have contracted with a *different* Cartoo clan to shoot down the plane carrying the returning exploration team, just in case they found anything interesting when powering the *Bats* computers back up. And as a matter of efficiency, this murder is partially paid for out of the completion bonus due the saboteurs, since they will not be needing it.

**squatters:** *Bats* is *technically* abandoned property outside of Earth's legal jurisdiction, so anyone, human *or* alien can go there and do what they want, in both a legal and practical sense. It could be that some other group has moved in and is living there, and does not want *Bats* to be moved. Discovering that squatters are on board, even for a structure this size, is not hard. To be habitable, the living quarters have to be heated, and that heat signature is readily detected, even on a vehicle the size of a small town. Similarly, for long-term habitation you will need some of the hydroponics beds active (or just grow plants in well-lit rooms or corridors), and any small food animals likewise need a place to live. This will add its own distinctive smell to the air currents downwind of such areas.



*The question is, what to do with the squatters and how? They might be human, they might be alien. They might be armed and will resist all efforts to move *Bats*, they may be meek and acquiescent. Or they may be meek and acquiescent while they plan their armed resistance. While *Bats* is outside Earth's jurisdiction, that does not mean Terrans who commit crimes are immune to prosecution. It just means that you cannot be arrested for crimes committed until you return to Earth. So, you cannot just shoot up or evict the squatters to fend for themselves. Similarly, if the squatters are aliens, there could be diplomatic concerns, and if they are *new* aliens, then there are special first contact protocols to follow.*

If you add into this that one or more of the squatters is a fugitive among their own kind (human or otherwise), or insane (do well adjusted people want to live in a place like this?) and there are all sorts of problems. Remember that the squatters have probably been here for months or years and know the layout of *Bats* pretty well. While long-term survival requires environmentally controlled areas, survival for days or weeks is possible with sufficiently insulated gear. And whoever the squatters are, they probably did not walk here, so somewhere on *Bats* there are one or more vehicles stashed, giving the squatters the potential mobility to zip around the outside of *Bats* and re-enter it on a different side, far faster than someone could be expected to walk from one side to the other from inside.

Adventurers will certainly have to put up with some of these complications, especially the ones they are not smart enough to anticipate. *Preparation is half the battle.*

**hostilities:** The Cartoo are being uppity along the borders, and it is possible a short flareup could happen during the expedition, grounding the recovery flight. This could strand the expedition for weeks or even a month or two, well beyond the duration of the supplies they brought. How this interacts with the other possible complications is unknown. At some point, a decision to evacuate may be made. The crawlers used to get here have unlimited endurance at low speed and good environment controls. They have folding bunks and can deploy dome tents for sleeping, but they would still be obnoxiously cramped for journeys of more than a few days. However, they can get the exploration team a hundred or two hundred kilometers closer to home each day, so they *could* make it to friendly territory in a few months. *If the team does not go crazy and kill each other during the trip.*

### **Finale**

Remember, this scenario is *not* really about reactivating *Bats* and starting home with it. It is merely to investigate whether or not reactivating it is even practical. It will take dozens of cargo flights and hundreds of techs to install the necessary gear just to restart the engines. This preliminary expedition is to inspect, measure and test dozens of internal systems, mandating that small groups be scattered throughout this massive vehicle, leaving plenty of time and room for problems to pop up. The scenario is expected to take at least a couple of weeks, after which the team notifies their Earth contacts via the long-range radio in the crawlers, heads back to the rendezvous point and is picked up by cargo plane. So, including pre-expedition packing and briefing, flights, crawler transit and post-expedition debriefing, the scenario could take upwards of a month from start to finish.



## Pre-Exodus notes

Much of the following info is completely lost to humanity, and is provided merely as background for the gamemaster, should they wish to have an early post-Exodus campaign or want to use it for occasional bits of revelation or discovery by the players. We are presenting it as 'what actually happened', but feel free to modify or elaborate on it, if for no other purpose than to keep your *players* guessing.

Aethos was not spotted by Earth until shortly before it began decelerating, which was early in the 22nd century. This was not due to any sort of technological subterfuge by the Aeth, but rather simple oversight and sheer chance, as the closely spaced white dwarfs were simply not where people or automated telescopes were looking. This was partially because humanity had more pressing physical and budgetary concerns closer to home. Global climate change and increasing demand for finite resources had caused great international tension and financial upheaval by the mid 21st century, and dealing with these problems delayed manned exploration of the solar system on the scale most 20th century futurists had expected. Earth at this time was still hundreds of nations, with a handful having the lion's share of wealth and force projection. By this time the United States had fallen to 'former world power' status, being much like Britain or France of the late 20th century, a nuclear power with a small, high tech army, capable of defending itself and beating up small nations at a long range, but no longer capable of winning and holding an empire by force. China had usurped that role, but failed to learn the lessons of history and was not doing too good a job of it.

In the most developed nations, standards of living could be very high, and fairly inexpensive genetic treatment of aging and disease had raised life expectancy significantly. Electronics had finally bumped into a limit that prevented further use of Moore's Law, but personal information devices, life recorders and other tech made near-intelligent personal devices practical and affordable. Even some extropian technologies like avatar intelligences were starting to happen. But at the same time, there was still crushing poverty and billions of have-nots, sometimes even in the most developed nations and high-tech cities. In short, the situation would be a familiar one to you, with some higher-tech trappings and new names in the headlines.

Nonetheless, by the early years of the 22nd century, humanity had solidly planted at least one foot in space, with permanent Lunar and Martian colonies, though the populations were measured in the thousands for Luna and the hundreds for Mars. Fusion and ion drives made it possible to consider manned exploration of the solar system, and while it was still quite dangerous, brave men and women were pushing the limits of human-occupied space.

Once Aethos was detected, to say there was some consternation would be a *massive* understatement. It caused a worldwide panic, riots, looting and near-collapse of the global economy. This settled down once people got it through their heads that it would not be a real concern to anyone except their children or grandchildren (Aethos would arrive in the vicinity of Earth in the late 22nd century).

Aethos changed course ever so slightly, angling to use the Sun's gravity to aim Aethos at its next destination, clearly *not* planning to stop here, but merely using this solar system as a waypoint on some longer journey. Humanity hoped to learn from the creators of Aethos, but really just hoped Aethos would go...and keep going.



Numerous communication attempts were made, but none were responded to by the Aeth. Deep space probes were sent, showed pictures of the surface, the civilizations on it and the scale of engineering involved in Aethos, but the probes were ignored by the Aeth, save for any probes with nuclear power plants, which were vaporized without trace or warning before reaching the orbits of Aethos' white dwarfs. *No manned missions were sent.*

While Earth's probes were mostly ignored by the Aeth, the probes were not ignored by the surface dwellers of Aethos. One of the more ancient ones (whom we eventually called 'the Ancients'), monitored Earth emissions for decades, learned our primary language and communication protocols, and sent us a warning of what was to come, including tidbits like 'the Aeth don't like nukes'. Despite censorship attempts, word of this got out and caused *another* panic. With the arrival of the Aeth still decades off, Earth governments engaged in a crash course of building colony ships to get *some* people to Mars, and a massive, economy-wrecking effort to build space-based weapons and orbiting warships, all of which they had been warned against by the Ancients.

The Ancients' advice to build large, non-nuclear re-entry vehicles to deliver Earth's most precious heritage items and people to Aethos was ignored and considered defeatist. One wealthy philanthropist attempted a private effort to do this, but the ship suffered a mysterious accident in orbit and was lost with all crew, disintegrating on uncontrolled re-entry over the Pacific (there are some variants of the *EDF Tiberius* story that use this vessel).

So, after about sixty years of absolute manic warmongering, propaganda, near-police state conditions and record industrial output, Earth was ready to meet the invaders with fusion-powered space dreadnoughts, antimatter powered gamma-ray lasers, lots and lots of nuclear missiles, and even a few smaller asteroids steered into a collision course with Aethos. The Ancients sent a final message that said in effect 'don't say we didn't warn you.' Aethos launched the massive ships it carried for refurbishing and supplies, ships that met these needs by *dismantling* other planets...

The Aeth ignored Earth's defenses, and Earth's attacks were similarly useless. No meaningful damage was done to any Aeth vessel or to Aethos itself. Deconstruction ships hundreds of kilometers across shaved off parts of the continents and oceans like a razor peeling a watermelon, stripping biosphere, atmosphere, minerals and water, paying particular attention to concentrations of certain rare elements, but otherwise seeming to operate at random. Some Aeth ships actually landed, and scooped up sections of terrain more or less intact, taking them back to Aethos and depositing them adjacent to each other like chunks of sod. Other Aeth ships mined asteroids, and just spread their debris along the northern latitudes of Aethos, a shell of protective rubble kilometers thick to slowly ablate away on the next leg of their journey.



By the time the Aeth were done, Earth had been peeled down to the mantle in many spots and was no longer capable of sustaining life. The Moon had been knocked from its orbit into an eventual collision with the Sun, the other inner planets had their orbits perturbed and Mars was the only spot in the solar system with a human population large enough to be viable. However, this colony eventually failed in the centuries after the Aeth left, and the only reservoir of humanity that remains in the universe are those who survived being transplanted to Aethos.

The survivors, a fraction of a fraction of a percent of humanity, first watched the early stages of the Aeth attack on what was left of Earth's media infrastructure. They saw entire countries shaved off the map, nations peeled down to the glowing magma beneath. Then the Aeth ships came for them. Terrified, expecting imminent, horrible death, they used their final moments either in futile defiance or silence with loved ones or prayer, or maybe all three. And then the sky went dark as the Aeth ship descended, and the earth shook as it peeled but did not destroy the land they stood on. Buildings crumbled, electronics and lights failed. The darkness and deafening sound and shaking one could not even stand against went on for hours, every moment of which people expected to be their last.

And then, it ended. The shaking stopped, a sliver of light came in from the horizon and expanded into a full sky as the Aeth ship departed. The survivors were in equal parts demolished and elated. The world around them was in shambles, nothing worked, countless victims lay buried in the rubble. But those who remained...were *alive!*

Sometimes it was days before people realized they were not on Earth anymore. The sky was filled with dust and ash, obscuring Aethos' three suns. Radios did not work, and the pressing needs of food, water and digging out the few survivors in the rubble took priority.

The Aeth artifacts known as Orbs were discovered, and were both a boon and a bane. Turing their discoverers into something out of a superhero comic, these newly-minted supermen were able to shift tons of rubble, recon the new territory of humanity and provide some much needed hope and a fully fluent liason to our new Tuaqq neighbors.

*And almost single-handedly force the Cartoo into a stalemate.* The Cartoo attacked as soon as the dust settled enough for airdropped mechanized infantry and the lava on the border cooled enough for heavier vehicles to traverse it. The Orb-men, plus thousands of tons of surplus war materials 'loaned' to humanity by the Tuaqq and ferried by Orb-men or Tuaqq airdrops, managed to force the Cartoo advance to a standstill, and slowly and painfully push them back to the edge of Terran territory. Humans, having just lost Earth, were beaten down, but in no mood to be beaten down any more and fought like they had nothing left to lose.

This unified the survivors in a way that forged a new humanity, but through circumstances that later generations could only read about in a vague way. The survivors, millions of them, were reticent to put the full details of their experiences in writing. Each knew that every other survivor went through the same thing. Each knew of the terror and the suffering, and few would bring it up in detail, even to their own children. By and large, they carried it silently and to their graves, leaving only a few detailed accounts behind.

**!** The author's uncle served in the Pacific Theater during World War 2. He received a Bronze Star for his service, and his family never knew about it until his death, fifty years later. He went *through* things and *did* things in the islands of the Pacific that he never told to anyone, and to those who *also* went through it, nothing *needed* to be said. This is the sort of thing the original survivors of Earth felt and carried with them for the rest of their lives.



## ORGANIZATIONS

One of the *big* aspects of **Aethos** is dealing with your fellow humans and organizations they use to manipulate or control things. Many of these have been mentioned, but none have been given a lot of detail. What follows is going to be the high points of some groups the adventurers may run into or afoul of.



### Terran Security Office

Adventurers are going to be humans, which means they are subject to Terran laws, and they have to deal with the shall we say... idiosyncracies of Terran government. Terran government works for the most part, but it has its less palatable elements, elements which will be of interest to the gamemaster.

From its conception, the Terran government has been aware of humanity's precarious position on Aethos, and the importance of controlling and manipulating information in order to steer public perception and attitudes in the most productive directions. Because of the immediate Earth-Cartoo War after the Exodus, the key leaders afterwards tended to have military backgrounds. While the Terran system of government is *genuinely* a representative one, it has its secrets. Among them is that the original Constitutional Convention had *secret* provisions, and grants the government certain sweeping legal powers that very few know about. So there was secrecy from the very start. Originally it was well-meaning. Human existence on Aethos was a precarious thing, so while the best military intelligence was that Old Earth was gone, the fiction of valiant survivors on Old Earth driving off the Aeth was seen as a better option. Similarly, the Constitutional Convention school children learn about had little to do with what actually happened. Groups that refused to integrate with a unified humanity were cut off from all resources, and anything they had of use for the rebuilding effort was confiscated, by force if necessary.

The representatives of Old Earth governments and militaries that made up the structure of the new Earth government *were* heroes and statesmen, but they were also pragmatists who realized that some of what government needs to do, needed to be things the people governed would not approve of...

In particular, the government is structured such that information is compartmentalized and is only available as a whole to a few key individuals in certain agencies. For instance, census information is only collected by and only available from the government. So, the government can arbitrarily declare what the population is in a given area, within obvious limits. So, if the government wants a state to have a little more or less clout in the Legislaat, it can simply tweak the census data. Similarly, military recruitment, disease data, economic figures and such are impossible to accurately collect by the private sector. So for instance, finding out how many cases of Spores have happened in the past decade is only available from the government. It cannot be collected privately, since information of that kind cannot be released by private hospitals because of patient confidentiality laws.

Now, there *are* private concerns that attempt to collect this data indirectly, assisted in large part by Earth's electronic networks. Birth announcements and death announcements, newspaper reports of Spore cases, company earnings statements, that sort of thing. These can be collected from myriad sources and added together to get some comparison to official government figures. However, these private compilations may be done by corporations or political groups and are not available for public consumption nor are always available for sale on the private market. Knowing anything close to accurate figures would require some sort of appropriate Status or Friend or Favor that could give access to it.



Over the course of nearly a millennium it is impossible to keep government activities like potential data manipulation *totally* secret. That there *is* a shadowy government agency doing secret things is an open secret, sort of like the United States' National Security Agency. In this case, it is called the Terran Security Office. What *is* being kept secret is the full scope of what it does, and people sort of accept that. It *is* a secret agency, after all. It has 'government oversight' and a 'budget', so people *assume* it is all done according to the law. And by and large it *is*, it just happens to include some laws that the average person does not know about, and its own special internal court to try cases brought before it.

The TSO is largely responsible for perpetuating the 'known history' that everyone learns in school. And when ancient personal diaries or artifacts turn up that conflict with the official story, it is the TSO that quietly outbids everyone at antiquity auctions, sees to it that the item is stolen, or is damaged during museum restoration. And they track down any electronic copies of the information and generally bury uncomfortable bits of the past as deep as they can. Among the other things the TSO has kept below the public radar is some of Earth's most important history. The accepted history is that the current Terran government was formed after the first Earth-Cartoo War, and has operated more or less continuously since, with various changes in political parties and government philosophy. The *truth* is that in the past nine hundred years, Earth's government has been toppled by two coups, and engaged in three civil wars.

The TSO does not quite operate as a shadow government, but it *does* play kingmaker and *is* the spymaster.

If this seems impossible to hide, remember that the TSO can and does isolate news events and put its own spin on them. In addition, human memories are short and there *have* been several wars with the Cartoo. So, all the TSO has really done is put events in the perspective of external aggression. A coup might become 'martial law imposed because of human agitators in the pay of the Cartoo'. A civil war might be 'local chaos in the aftermath of a recent Cartoo incursion'. And since the Cartoo *do* have a well-deserved reputation as aggressors, and people *want* to believe they are all part of a unified humanity, they tend to go with the 'it's someone else's fault' explanation.

Local records that indicate a different history are assumed to be flawed, since they are *merely* 'local accounts', and not the 'big picture'. On occasion, a very inquisitive and bright academic type will uncover enough information to make them suspicious of the gaps and patches on the historical record. And when this happens, varying degrees of pressure are applied to discourage further investigation. Preferably something innocuous and diverting, like a sudden opportunity for a promotion or research assignment that would leave them little time to dig into the suspicious bits. Failing that, more coercive but inobvious means can be used, like being denied tenure or having their thesis rejected, or a building code problem that forces them to waste time moving to a new address. Tactics that give the TSO time to go in and clean up or doctor the data, or possibly cause the original research to be lost in an accidental fire, sprinkler malfunction or computer theft. The TSO does not do these things in a malicious sense. They genuinely see themselves as good guys (most of them do, anyway), who are doing a distasteful but necessary task to help preserve the last sliver of humanity in a dangerous and uncertain world. *The ends justify the means...*





Bear in mind that even very important events can be kept secret or their details muddled by even a fair and democratic government for a *remarkably* long time. Here in the early 21st century, some records from the Kennedy assassination in 1963CE are still under lock and key. British and American records from World War 2 still languish under 'Classified' labels seven decades later. The TSO does not have to keep things hidden *forever*, just until everyone alive who could remember or be embarrassed by them has died of old age, and no one still living really cares anymore. If you are an American reading this, do you know about the forced sterilization of 'genetic undesireables' in the United States in the 20th century? Does the 'Tuskegee Experiment' ring any bells? The *S.S. St. Louis*? Forced internment camps in the United States for American citizens during World War 2? The Greenwood Riot? *Out of those five fairly major and shameful episodes in 20th century United States history, how many did you even know about?* And of those you *were* aware of, how many do you have more than a superficial knowledge of? China is actively erasing Tianenmen Square from its collective memory, Japan does not teach its children about the Rape of Nanking by Japanese soldiers during World War 2, and in Turkey it is *still* a crime to accuse the government of complicity in the Armenian genocide of 1915CE (and in 2007CE a Turkish journalist was murdered over it).

Between the collective desire by the public to remain ignorant of certain things, the power of the government to suppress them, and a media willing to *not* report on what people do not want to hear, it is more than plausible that the past most people on Aethos *think* they know has little to do with what *actually* happened.

The TSO *almost* has the power to make Earth a police state, but those who made it possible nearly a millennium ago put in just enough checks and balances to stop this from happening. *Yet.*

Nonetheless, there is the possibility for abuse that can ruin the lives of individuals for no good reason, even if the TSO cannot control society as a whole. A small media outlet that publishes a story they were told not to might find itself shut down for workplace violations, revocation of business licenses, etc. Someone who insists on collecting information the government considers itself to have a proprietary interest in, could find their life savings vanishing to pay a fine levied by a court whose verdict cannot even be appealed. Someone who seems merely suspicious could find inquiries into their credit history, a tracker on their car, or all their communications monitored.

The TSO and the Arkivists have a love/hate relationship. The Arkivists find and have information the TSO would like, and also have information the TSO would *not* like to have revealed. The higher level Terran Arkivists have known about the TSO even before there was a TSO, and have managed to keep their own communication channels inviolate from snooping. The TSO knows who some of the most prominent secret Arkivists are, and suspects more. The Arkivists occasionally answer research queries for the TSO, and will even undertake operations that need to be deniable by the government. In return, the TSO does not harass or crack down on Arkivists who wisely keep their secrets to themselves. This relationship will be stressed by the Arrival, and whether it will hold, fracture or strengthen, no one knows just yet.

The public perception of the TSO is somewhere between spies and secret police, and the TSO runs several front groups online to both foster the former opinion and to collect information on people who think they are the latter. Some of the most vocal and critical online groups are in fact owned and moderated by the TSO. *What better way to make anti-TSO people look like conspiracy nuts than to encourage the nuttiest of them to speak their mind?*

Despite all of this, the TSO *does* do some good and necessary work. Their semi-legal interception of communications has uncovered corruption within the government, captured Cartoo-paid spies and thwarted assassination plots. They have recovered alien artifacts and kept priceless human heritage items from being exported to alien collectors. The TSO passes information to other law enforcement agencies and the TSO never stands in the spotlight and takes credit for it. Some TSO agents *are* on a personal power trip, and there are administrators who have their own opinions on what is legal and what is not, even within the loose TSO guidelines, but by and large members of the TSO *are* patriotic individuals who believe that what they are doing is necessary for the good and the survival of humanity, even if tactics they use are sometimes questionable. Adventurers might even think they are working for a private patron, when in fact they are merely unwitting contract employees of a TSO front operation.

In truth, it is probably unlikely that even the TSO fully knows what the TSO is doing. Individual operations may be under different department heads and details that would show conflicting operations might not make it to higher levels until one TSO operation causes another TSO operation to fail. And of course, *both* operations *and* the failure have to be kept from reaching the public...

In an **Aethos** campaign, the TSO can be the good guys, the bad guys, the cavalry that comes to the rescue and the people you need the cavalry to rescue you from, all at the same time...

## Organized Crime

As hinted at in the note on forbidden Customs, Earth *still* has organized crime. As a concept, this varies between races. The Ancients do not have it at all, though the nature of their internal academic debates could almost be a non-violent counterpart. The Cartoo are racially predisposed to organized crime, while the Tuaqq and Cartoo may have small criminal fiefdoms and specialities, but no major crime organizations.

Human organized crime is some strange hybrid between American gangs, Oriental Triads, the Mafia and the popular perception of all three as they existed at the time of the Exodus. The more violent, code and ritualistic aspects are at the lower levels, and the genteel but ruthless traditions are at the top. Amputation of fingers for failure is common at the lower levels, but redemption means you have permission to have them regrown. At the upper levels, there is an entire language of threat, appeasement, denial and arcane symbols that are only understood by the initiated. An innocuous turn of phrase might be a grave insult, but only in a specific social setting, or wearing a certain lapel pin on the left side instead of the right could be a challenge to someone's authority, or the manner of serving tea could convey more meaning than the conversation that takes place over that tea. This sort of thing would be an Area Knowledge that you could only get if your adventurer had an Unusual Background.

Organizationally speaking, crime's sphere of influence extends into government, industry and even religion. There are representatives of Terran government who are in organized crime, or are influenced by organized crime. Businesses from local stores to major defense contractors have ties or are influenced. And to some extent, government and industry influence organized crime.



The extent of influence can affect legislation, contracts and the like, but the influence is usually subtle and seldom seen. There are not briefcases full of cash changing hands or gangs of toughs trashing mom & pop stores if they do not get their protection money. It is lower key than that, but it can still have its violent elements and outbursts, especially if it is challenged or threatened. *Any cloud can turn into a thunderstorm if the conditions are right.* Like everything else about humanity on Aethos, the organized crime system has had a millennium to evolve into its present form, a slightly parasitic relationship that sustains the parasite and only slightly weakens the host.

### Religion

As mentioned, Biblism is the main religion of humanity, but it is not the only one, nor is Biblism a monolithic block of belief. Terran laws guarantee freedom of religion, treating most religions as a Custom. Biblism is the most popular of them, and for better or worse, most members of government who follow a religion are likely to be Biblists. Joodists, Seekers and Neogians are less temperamentally inclined to seek public office and try to influence other people's lives, but there are some of each in the Legislaat. Aethologists are somewhere in between in terms of temperament and desire to control things, but do not get a lot of votes.

As with Old Earth religions, there is money to be made from the faithful. Each of the Customs has numerous blogs devoted to it, electronically broadcast ceremonies and commentaries, news shows aimed at followers of that Custom, as well as legislative watches, support for political candidates, merchandise geared to that Custom ("our latest wristwatch can point the way to Old Earth, no matter where you are!"), and ubiquitous appeals for donations for causes of varying worth.

People who hold a Custom that is one of the religions of Aethos are generally pretty set in their ways. It is unlikely a Joodist will become a Seeker, or a Seeker a Biblist, but those who are moderates in these Customs are generally pretty tolerant of the others. However, the more specialized a Custom gets, the more likely the person is to be intolerant, willing to impose their views on others if given the ability, and the more likely they are to filter what they see, hear and experience through the filter of their belief *before* deciding whether it is valid.

So, if someone is an Apocalyptic Polygamist Biblist, it is highly unlikely that anyone is going to convince them that they are wrong about *any* of these three Customs, let alone all of them. And, *everything* they hear, say or do is going to go through the 'apocalyptic polygamist biblist' filter in their head to determine if it is right or wrong, rather than a more conventional common-sense or fact-based filtering mechanism. A ballot initiative to provide aid to starving homeless orphans would be voted against if it countered their core beliefs. They would disown their children or quit their job or pack up and move if it were the only thing to do.

Fortunately, the more specialized the Custom, the fewer adherents it has. *Unfortunately*, the more specialized the Custom, the more likely it is that its followers are going to be politically or socially active. *Which is to say, doing things that will create situations with adventure possibilities.* It seems to be a uniquely human trait that those whose beliefs are most in the minority are the ones who want the most to force them on the majority.



! Some of the most revered historical figures on Earth are Biblists and some of the most worthy charitable organizations are founded on the core Biblist principles. In some ways, this *genuine* respectability and morality makes it easier for those who lack *either* quality to gain positions of influence. They may draw funding from the those who can least afford to give, glibly make promises to the gullible, stoke hatred in the disenfranchised, make promises they cannot keep, and then blame ideological foes for their own failure to to deliver. In **Aethos**, the biggest and most influential extremists of this type happen to be in the fringe Biblist camp. The superstitious awe of the Aeth that many people have makes extremist religious appeals more popular at a gut level than extremist secular ones. These extremists do not beat their children, kick puppies nor go “bah, humbug!” at Christmas. They just happen to think that *their* core beliefs have more value than yours, and if necessary for their beliefs to triumph, that their beliefs have more value than *your life*. *Better your body should die than your soul perish...* Parallels could also be drawn to pre-WW2 Germany. To a lesser extent, *each* of the faiths in Aethos has the same sort of problem, it is just that Biblism is the most popular and influential, so it is the first choice for those seeking to manipulate things to their own ends.

## GAMEMASTERING AETHOS

*A few final notes.* **Aethos** is really a pretty straightforward setting once you wrap your head around the Aeth. It is a hard SF gameworld with several types of aliens, that just happens to have no real space travel aside from Aethos itself. The aliens are not in different star systems, they are right over there, across the border. There are no human countries with national borders, there are Customs that put the ‘other’ everywhere you go.



When you put your first adventures together, leave out long-term problems like “what’s going to happen in a hundred years?” and just deal with the immediate concerns, plots and problems people will have. Everything that you could arrange at a starport bar you can do on Aethos. There is politics, exploration, smuggling, investigations, bodyguard work, the usual suspects. Put together adventures like you might for any other SF setting. Then, think about how the unique setting, humanity’s past and potential future can figure in, either as a direct plot element, foreshadowing, side track or red herring.

A successful **Aethos** campaign does not just have the players interested in learning more about the things you have not told them, or which they find out they only thought they knew. *It is about them making a difference.* The adventurers are, or should become, key players in the coming decades, either because of what they know, what they have done, or what they can do. This is not to say that every adventure is a make-or-break situation for the future of the human race. But every adventure *is* important in the sense that it hones the skills and instincts of the players and adventurers to the edge they will need at some future date when everything that matters will hinge on *their* actions.

There is no ‘*this* is how a campaign is meant to end’ chapter. It is assumed that a campaign will end at or shortly after Aethos stops in the next system, but *how* it ends and how *happy* this ending is, is up to you. To guarantee the survival of humanity would be nice, but is not a *certain* outcome. We might be stronger afterwards, we might be weaker. We might be changed as a race and culture, or remain the same. Odds are pretty good, however, that the Aeth and Aethos will endure. Other than that, it is up to you, and you will likely find that the journey itself was more important than the destination.



Blowout at Exit 16A, by Till Nowak  
[www.framebox.com](http://www.framebox.com)



*The device has the annoying inscrutability that is the hallmark of anything Aeth, so we are certain it is not merely an advanced construct from an extinct or unknown surface race. I am regretting giving in to my research assistant's demands for a full regeneration clause in his employment contract. It took a medical computer and three specialists a full week to turn all the pieces back from their inside-out state and reassemble them into something that the regen tank could start to work with. Interestingly, some side effect of the Aeth device kept him alive and conscious the entire time. The screaming was dreadful.*

*- Arkivist data log(intercepted)*

## INTRODUCTION

This chapter is going to cover some specific ins and outs of the tech used by the various races on Aethos, some personality in addition to dry game stats, as well as some cultural perspective on why the various races do certain things the way they do. It is more than *just* a gear listing, and just the background of technology can spur some ideas for your adventures.



## Aethos itself

As a technological artifact, the artificial world of Aethos operates at the limit of what is theoretically possible. We do not mean what is theoretically possible by human standards, but what is theoretically possible for *this* universe. Aethos is a sublight vessel, so there is no FTL in this universe, and to the best of anyone's knowledge, there is no FTL communication or weaponry either.

What can be observed shows that the Aeth have the ability to manipulate matter at a level far beyond our understanding, able to assemble and disassemble items down to an atomic scale (or smaller), and combine them into forms with properties that by all our knowledge, are simply impossible. Their stellar propulsion system manipulates dark matter, and their conventional spacecraft use some sort of reactionless or gravity manipulation drive. The Aeth have a fear or a cultural prohibition against fission, fusion or antimatter, though it is unknown if this is simply a prohibition they place on other races, or one they also adhere to for themselves.

Aeth technology is 'out there'. We can imply certain things about Aeth technology from the Aeth themselves and the nature of Aethos. For instance, we know that the Aeth do not allow the surface races to possess any sort of nuclear technology, whether fission, fusion or antimatter. They enforce this by utterly destroying the offending technology and often everything within several kilometers. This implies two things: The Aeth can detect and characterize nuclear reactions with great precision, even through scath, and the Aeth have no technology to prevent or suppress atomic reactions of this type. We are pretty sure of the former, but the latter is merely an assumption. The Aeth are *exceptionally* good at seeing through any form of subterfuge.



One of the things we know about the Cartoo is they once tried to smuggle a self-starting fusion reactor into enemy territory in hopes of provoking an Aeth response. Despite being made with enemy tech and having no radioactives in it, the Aeth response sterilized the Cartoo city where the device was *made* as well as the device itself. Their next attempt assembled the device completely outside of Cartoo territory with parts that had never been inside Cartoo territory. Everything within about four kilometers of the Cartoo Security Directorate died, and anything entering the area for about seven years also died. How the Aeth figured this out is anyone's guess, but after that, the Cartoo got the hint. That was a few thousand years ago.

The Aeth also apparently *cannot* create something out of nothing. While they can create and manipulate *prodigious* amounts of energy, they still strip mine planets for raw materials. For a race that can accelerate a small solar system up to relativistic velocity, they still use conventional matter for shielding and cannot create a force field to protect them from relativistic debris. *Again, an assumption.* Perhaps they merely choose not to, or have some strange Aeth belief or reason to not use faster-than-light or radiation-deflecting fields while travelling. The Aeth have reactionless drives to propel ships the size of Kansas, can create a structural material like scarth, and disassemble conventional matter down to its component atoms at range, yet they use massive but conventional attitude correction jets and rely on a bizarre variant of *falling* to move their manufactured world around. Clearly, the Aeth technological aesthetic is not entirely consistent from a human viewpoint and the difference between what 'the Aeth cannot do' and 'the Aeth do not do' is something is one which we are *still* trying to figure out.

As far as Aeth portable artifacts go, we can't understand them, but we can still use them. *Sort of.* Probably not correctly, certainly not to full effect. Like a racoon using a walkie-talkie, a chimp using a pistol or a cat sleeping next to a warm fireplace. For higher functions, Aeth technology does *not* follow a predictable pattern or any cause-effect relationship that humans can understand. We can at best figure how to do a very simple subset of a device's functions, but by and large we do not know why what we do works, nor how the device itself does what it does. You push the button and some fraction of the time, it works. Of course, by 'pushing the button', we might mean 'douse it in UV laser radiation while two of the suns are in the sky on days that are a prime number of days since the last time it rained.' *It might as well be magic.*

Experimenters with such devices either are superstitious or tend to develop superstitions about the objects. Very few Aeth objects are straightforward, and even if they are, their original function almost always remains unknown. There is no way to tell if an object is the Aeth equivalent of a paperclip or a hand grenade. Though the hand grenade is more likely to leave a big hole in the landscape. Note the term 'more likely to'. *Aeth paperclips can be dangerous, too.*

*The Aeth do not really care.* One of the few characteristics they share with humans is that they sometimes lose things, and sometimes throw things out. That surface creatures have a fascination for such items has the same significance to the Aeth that we would give to a pair of crows fighting over a shiny marble.

Aeth personal technology is large enough that it really needs to be vehicle mounted, and such devices include what to us are amazingly advanced armor, weapon, communication, mobility or medical technologies. Aeth information technology exists and can be made to work, but no one can understand *what* it does... In fact, simply assuming that it is information tech might be wrong.



What is assumed to be some sort of implanted Aeth technology *is* small enough to be hand-held by humans. Some of it has functions which appear to do nothing, but most of what can be understood has a medical or biological or communication function, but a few have some sort of armor or environmental protection function. What all of these devices were originally for is at best, a guess, and the most honest of human researchers will admit privately that their best guess is probably still wrong...

Here are a few of the hundreds of Aeth tidbits recovered over the past several centuries:

**scarth:** Scarth is the word for Aethos' structural material. Yes, the similarity in name is an homage to Larry Niven's **Ringworld** books, though in Aethos the word may be derived from a term the Ancients use. Scarth is occasionally exposed by impacts on the leading edge of Aethos during interstellar flight, and threads or chips are sometimes found after they are blasted into orbit and fall back down again, or splinters can be pulled loose from the edges of impact sites with diamond-tipped hydraulic chisels. Scarth is by all analysis by human science, unfathomable, unworkable and nearly indestructible. A piece sufficiently large to put on the tip of a weapon will make that weapon armor-piercing against *any* non-Aeth material, as will scarth dust mixed into the metal of a conventional armor-piercing projectile. No piece larger than a thumbnail is known to exist. A splinter the size of a sewing needle is worth about a thousand Credits.

What is known about scarth is that it is a uniform light grey in color, about the same as moon dust. Under a magnifying glass it has a fine orange peel texture. It is harder than *anything* and about the same density as titanium. It reflects and absorbs virtually all wavelengths equally and has no unique spectrographic signature. It is magnetically transparent, an electrical insulator, a moderate thermal conductor and has a specific heat about seven times that of water.

Scarth does not melt, burn or react with any mundane chemical under any conditions. Most adhesives will stick to it about as well as they do anything else. It is not infinitely strong, merely *many* times stronger than the finest structural alloys or synthetic materials. Impacts with small debris at .1c splinter Aethos' scarth surface like bullets splintering wood, so scarth *does* have a grain or preferred orientation. When Aethos' scarth surface is damaged for any reason, eventually the Aeth will repair it, and these repairs are indistinguishable from the previous undamaged surface. No one has ever seen these repairs happen. Even automated recording devices fail to notice the repairs. A recording made during the repair will not show the repair when played back, but a recording made after the repair clearly shows it as repaired. It is one of those head-scratching things where people are constantly trying to figure out how it was done, and is just another example of how we are unable to understand how the Aeth think and operate.





**stasis cloth:** An object ranging in size from a handkerchief to a medium-sized blanket, *always* in the shape of an irregular polygon, made of a scarth-like material no more than a micron in thickness. Not indestructible, but pretty tough for something a hundredth the thickness of a human hair, and the edges of the cloth are *hellishly* sharp (but fortunately very flimsy). If an object is placed on it and all of the edges are overlapped, the object is placed in a form of biological stasis. All processes associated with biological energy transport are suspended. Time passes, but no cellular growth, decay, chemical reactions or electrical activity occurs. One of the larger items of this type is in the emergency medical kit assigned to the Prime Minister. Another is currently wrapped around a 5th century Biblist patriarch/prophet, whose ailing and ancient but still living body was encased in an Aeth 'shroud', to be unwrapped when a particular prophecy he made comes to pass. Lesser examples are in the inventory of various government agencies and a few rich collectors. If the stasis cloth is damaged in any way it ceases to work and will disintegrate into nothingness (it ceases to exist, leaving no mass or energy behind) in a few hours.

**fractals:** These are objects ranging in size from the size of a notepad to that of a small table. Their general form is a single-surface three-dimensional object. That is, they are configured so that their inside and outside are one continuous surface. The composition appears to be a flexible metal, but is actually a single continuous molecule composed mostly of various metals, but with significant amounts of other non-radioactive elements. A fractal is mostly its very thin surface, and is only a few kilograms in mass at most. There are two constants about fractals. The first is that a large part of the surface of one shows a non-repeating fractal color pattern, which changes over time, going through a complete cycle in several weeks.

Analysis indicates that this pattern and its changes convey information, but no one has figured it out. Different fractals may have the same pattern, or different ones. Ones with the same pattern are *exactly* synchronized. The other common factor is that one band on part of the exposed surface has scarth particles embedded in it to make it more abrasive.

Because of the potential to unlock some aspect of Aeth language, fractals are highly sought after. Ones with a new pattern are worth about twenty thousand Eur, while ones that duplicate existing finds are worth about a tenth this unless it is the *only* duplicate, in which case it is worth about five thousand Eur.

**universal:** This is irregular lumps of a material that defies all but superficial analysis, save that it is not scarth. It has been found in sizes ranging from a piece of old chewing gum to a misshapen apple. Its texture and consistency is about the same as rubber, though it is harder than diamond (you can squish it, but not cut it). If a lump of universal is placed on the damaged part of an object and it is bombarded with a precise mix of infrasound and ultrasound, the universal will fix what is damaged by substituting exactly as much of its mass as is needed for the missing or broken parts, with the remainder falling away unused when the repair is complete. This repair happens regardless of the complexity of the item and nature of the damage. For instance, you could cut the CPU out of a computer with a hole saw and universal would replace the CPU and the circuit traces and the circuit board itself. A gun with a missing piece would have it replaced with an exact duplicate of the piece, right down to the correct serial number on the part. How the substance figures this sort of thing out is unknown.



Universal has a few quirks, as might be expected. To date, it has not been made to work with other Aeth devices. It does not work on still-living materials and it will not replace any radioactive isotope. And the repair lasts for 43 hours, 7 minutes and 17 seconds, after which that bit of universal turns to a powder composed of equal portions of carbon, iron, and osmium.

Universal is interesting, but because of the impermanence of the repair and the special sonic equipment needed to activate it, universal has no profoundly unbalancing uses. It is worth several times its weight in gold for the government bounty, so even a small piece is worth several thousand Eur. What the government wants it for is anyone's guess, but over the centuries they have certainly amassed quite a bit of it.

! It would be invaluable for restoring function to ancient Terran or alien artifacts long enough to recover any information on them.

**stickem:** These are whiskery filaments about a centimeter long, tapering from a diameter of about 100 microns at one end to too small to measure at the other, with a slight flaring at the wider end to about 300 microns. They are pointy enough to penetrate any mundane matter all the way to the flared end, and are in some atomic sense, barbed. They cannot be removed except through force, which pulls out a plug about 1 centimeter in diameter of whatever they were inserted into, or by application of a 421 volt charge modulated at 34,229 cycles per second. Each filament of stickem has a tensile strength of nearly a ton, and if this is exceeded, this snaps the filament and it loses its properties. The flexibility of the filaments is limited, making it difficult to make a melee weapon out of them. An off-angle insertion with too much force or lateral motion will just snap the filament.

Stickem filaments are presumed to be shed from individual Aeth as they travel the surface. They are common enough that individual ones are only worth about 10 Eur each. They have limited industrial and commercial application, like specialized locks and climbing gear. The flared end allows the filament to be anchored in another material, and a small circuit provides the necessary voltage to unstick it as needed. Their fineness means they can penetrate human flesh with zero resistance, zero pain and zero damage, unless of course, you try to remove it. Barring an electrical removal tool, the only way to remove a filament without damage is to push it all the way through, anchor the tip into something else and then pull it out the other side.

**erasers:** These are cubes that have only been found in an exact size of 1.1231 centimeters on a side. Actually, 1.1231 centimeters and a lot more decimal places in a sequence which like  $\pi$ , apparently does not repeat, at least within human ability to measure the size. When one specific side is rubbed on an object made of mundane matter, any part touching the eraser is scraped off to a depth of ten atoms of the most predominant element in that depth of the item. The mass removed apparently vanishes, and microscopic exams of the process gives no clue as to how it is done. Individual erasers have a useful life of several thousand hours of use before they become useless lumps, and they have many industrial and commercial applications. Placed on the end of a high speed drill bit, it will erode a perfect 1.741 centimeter hole through any mundane material with no heat, no friction and very little sound, the rate of drilling limited only by the rotational speed of the drill (20 atomic radii per rotation of the bit). Like all Aeth artifacts, they are required to be turned over to the government, which pays a flat 2000 Eur bounty for one in working condition. The government auctions them off to the highest bidder, usually for a price of about 5000 Eur.



Because of the ease with which they can bore out locks, cut holes in safes and such, erasers are registered items and they are generally considered 'questionable objects' if one is found in your possession without good reason. A number of industries use them, and several industrial standards exist just for compatibility with eraser-based holes, dimples or other voids created by contact with an eraser.

**Orbs:** The Aeth can and have made technology specifically for use by a particular surface race. They did this for humans when they transplanted them here. In our case, the technology was in the form of grapefruit-sized spheres that converted, nano-engineered or otherwise changed the first person to pick it up in one of several irrevocable and eventually fatal ways. However, these Orbs *did* make that person exceptionally powerful in the role of defending humanity against the Cartoo. Quite a few of these devices survived the first Earth-Cartoo War, carefully nudged into boxes with the proverbial ten-foot pole. Most of these were in turn used up in the second Earth-Cartoo War, and only a handful survive to the present day. These are a *closely* guarded government secret. No one even knows if they still work, and knowing that it is an eventual death sentence to use one, there are not many volunteers willing to try them out should a situation desperate enough arise.

In addition to the handful in government possession, the Biblist Hierarchy has one in its possession, a most secret and holy relic. They also have what they call the 'Cloak of the Prophet', which was supposedly shed by the Prophet as he ascended into the heavens after the first Earth-Cartoo War. It appears to be inert, but it did not disappear as all other Aeth-related items of that era did after being used up. It still bears the imprint of the Prophet's back and arms, even down to the wounds he took from several Cartoo gauss *cannon*.

Unlike the Shroud of Turin on Old Earth, the Cloak of the Prophet is a secret relic. Not as closely held a secret as the Orb, but to have seen and touched it is only for the most highly placed and genuinely devoted.

**!** While Orthodox Biblism considers the Aeth a genuine evil, they have a complicated internal theology about the origin of these artifacts that makes human use and veneration of them acceptable. This theology is itself a closely guarded secret, known only to those who know of the artifacts.

**Spores:** There are leftover bits of Aeth tech still floating around in the air and water. *Literally.* After the recipients/victims of the Orbs died, their bodies violently disintegrated and the fine molecular dust that remained was scattered through Aethos' ecosystem. But this did not mean it was inert. The fragments, by some unknown Aeth tech, still had potential, and perhaps even 'purpose'.

It cannot be called nanotech, or a biological agent, but it is both and neither. With characteristics of both life and machine, they are simply referred to as 'Spores'. The individual components of spores are virtually everywhere, tiny fragments of seemingly inert molecular chains with a few fragments of the uncategorizable Aeth elements tacked on. If you get *enough* of them, of the *right* type, in the *right* environment, enough of them join together to begin self-replication. *Maybe.* This hits a person like a disease, and like a disease, the body eventually mobilizes defenses and rejects it...or dies trying.



However, death is very uncommon as a direct side effect. More often, death comes from a victim's fellow citizens, who are often afraid of catching it, or by the government, which is always interested in getting Spore victims as soon as possible for experimentation. Spores as a malady are very uncommon. The human population of Aethos has maybe a dozen or so cases of spores per year, which means you have about a .000004% chance of catching it in any given year (roll 9d and if they all come up '6', you win!).

**!** A natural exposure is a *deus ex machina*. If the gamemaster says it happens, it happens, no Health roll will keep it from happening. However, since it is potentially fatal, it is the sort of thing that the player should have some sort of input on, either to choose to avoid a circumstance that seems suspicious, or to agree to something unspecified but risky that could have great benefits to the adventurer, turning it into a cooperative plot device.

If you catch spores, you start taking damage. Two or three days after exposure you take 1 lethal Hit of damage, and take 1 additional Hit per day until you either shake off the spores or you die from them. After taking 3 Hits of damage, your immune system has rallied enough to try and fight them off and you can start making Health rolls to do so.

*Catching spores is not all bad.* As a leftover from use of the Orbs some centuries ago, a person with a case of spores tends to develop some sort of random ability. Roll 1d+0 twice:

- 1: offense
- 2: defense
- 3: movement
- 4: regeneration
- 5: increased effect on one power or +2d on a random attribute (roll again and ignore this result)
- 6: extraordinary range on one power or +2d on a random attribute (roll again and ignore this result)

The way it works is that if you start catching a case of spores, you usually know it. There are physical signs, like shiny metallic patches on the skin, having your hair fall out in fractal patterns across your body, having old scars disappear and other symptoms that mundane illnesses simply do not have. *If you are going to catch it, you are going to catch it.* In its early stages it is something the body has no defense against. Only when it starts replicating and showing symptoms do you have a chance to throw it off. And once it starts showing symptoms you also start developing a power or powers.

**offense:** You can project needle-fine slivers of biologically refined steel from your fingertips at hypersonic velocity. These have a damage of 5d+0 and an Accuracy of 4 if you aim. You can do this as a major action, just like firing a weapon, and understanding how to aim is instinctual. There is no sighting reticle, no heads-up display, you just aim and it happens. The skill roll used is Agility+2d, regardless of other weapon skills known. Increased effect means either autoburst capability or +2d damage (choose one or the other). Having extraordinary range means you have an Accuracy of 8 and they are armor-piercing. The very small size of the slivers means they shed velocity quickly, and lose 0d+2 of damage at 16 meters and each range band past this.

**defense:** Your entire body gains a rigid armor of 5d+0, yet your skin remains flexible and supple. Increased effect means +1d and protection against armor-piercing effects. Extraordinary range means that you can additionally ignore non-damaging effects of similar threat level, like intense radiation, nerve gas and the like.

**movement:** You get a Health of 5d+0 for movement purposes. Increased effect means x2 multiple on distance. Extraordinary range means you can swim or fly at the increased rate (choose one or the other). Flight or swimming happens in a reactionless sense (no wings or fins required).



**regeneration:** You recover one lethal or non-lethal hit from a given damage source each time level after it occurs. A +2d effect means you recover double the normal amount. Extraordinary range means that you can lay hands on someone and if you are not injured, they begin recovering damage at the rate you would, though you cannot heal and heal someone else at the same time. A side effect of this power is nearly unlimited Stamina. As soon as you recover the first non-lethal hit from excess Stamina use, you get all your Stamina back.

These powers start manifesting after you have taken 1 lethal Hit from the spore infection (and regeneration does not heal this damage). Each day after the third, you have to make a Health roll against a difficulty of the total of your die rolls on the previous table. Add all rolls that count, so it is possible you could have a total of four dice!

**i** If you rolled a '3' and a '6' on the previous table, the difficulty for your Health roll would be 9.

If you fail the Health roll, you take another lethal hit of damage and retain the powers. If you make the Health roll, you fight off the spore infection and begin to heal the damage at the rate of 2 Hits per day, and the powers go away when the last of this damage is healed. You keep rolling each day until you either fight off the spore infection or die. A person who dies of spores tends to have their body disintegrate in some bizarre fashion related to their power. A person whose power is offense might blow up like a grenade, defense might petrify the victim before crumbling into powder, someone with movement powers might teleport body parts in random directions, and regeneration could turn the body into a pile of organic goo with unusual properties.

When the last of the spore-caused damage is healed, the powers vanish. One universal side effect of spores is that it removes all scars and regenerates any damaged but still-extant tissue. It won't replace a lost leg, but it will undo damage from a stroke, heart attack or organ failure. After you take the first lethal Hit of damage, all *other* damage on you is repaired. If you are past your physical prime, getting a case of spores will knock ten years off your chronological age. You do not lose any S gained, and you do get back any A lost, which must be applied to Attributes as a normal gain of experience. Adventurers who are going to get this rejuvenation benefit should have saved experience to pay for it. A person who has been infected by Spores and survived is now partially immune to them and cannot be infected again by *natural* exposure.

It is possible to isolate spore fragments from the environment through use of sophisticated filtering apparatus and a *lot* of effort. The government does do this, at an exorbitant cost per potential exposure (i.e. the gamemaster makes it as rare as desired).

A person exposed to these concentrated Spores can fairly reliably be caused to exhibit symptoms. A previously unexposed person has to make a Challenging(9) Health roll to avoid suffering spore effects. A person who has previously had spores gets -2 to the difficulty of resisting the concentrated spores for each previous time they have had spores. However, drugs or injury can be used to lower a person's immune defenses if spore effects are definitely desired.

The downside of repeated exposure is that if a person's immune response is overwhelmed, it becomes increasingly difficult to build it back up. Add the roll of 1d to the difficulty of the Health roll to fight off the effects for each previous exposure. This makes it more and more likely that a deliberate second or third exposure will prove fatal.



It is technically illegal to deliberately infect someone with Spores, either to cause harm or for military, therapeutic or anti-agathic purposes. However, there have been very few prosecutions over the centuries and rumors are always floating around about some rich, famous or powerful person "taking the cure", or dying under mysterious circumstances while being treated for some serious health problem.

**!** In game terms, Spores have plenty of uses, and are within the reach of wealthy, well-connected or experienced adventurers. But the unavoidable problems with repeated use mean that most forms of abuse are self-limiting. The military does have a stockpile of Spores as a tactical asset in case 'super-soldiers' are needed, but these are guarded almost as much as the few Orbs remaining and both the concentrated Spores and the filtering program are a closely guarded secret. It could take sifting through several million tons of material to get enough Spores for one reliable infection chance. The cover story for such operations are things like recycling plants or river dredging or special filters at water treatment plants. The Cartoo and other nearby races know of the military program or suspect it, because they would do the same thing themselves, but there is nothing they can do about it.

No other surface race has Spores. In their own distant past, they probably had something similar, and their own Orbs, but over millennia, their spores have gradually decayed away or been used up. Even humanity's spores are becoming rarer than they already are. The rate of natural cases is a tenth what it was a century ago, and within a century there will probably be no more natural cases. *This is not generally known.* The government has covered up the previous rates of Spore infection, making the numbers of the past only slightly higher than they are today. Back then, it was to keep people from getting worried about Spores.

Today, the rate of decline is hidden to try and fool the Cartoo into thinking it is still common enough that human Spore filtering efforts can make battalions of spore-augmented soldiers on short notice if humanity is threatened.

The popular attitude about Spores varies. Most people view it as a sort of Aeth-related disease, and give a victim a wide berth. Even though it is not contagious, there is all manner of irrational belief. People won't let you use their toilet because they are afraid you'll contaminate their plumbing. You might be considered armed and dangerous, mentally unstable, under Aeth influence, and so on.

However, the Church of the Eschaton considers those who have Spores to be blessed by the Aeth, and to receive semi-divine wisdom from the Aeth along with their powers. That the Spore-afflicted do not know this wisdom does not mean it is not there, just that it may take a while to be recognized. The upper hierarchy of the Church of the Eschaton has their own Spore filtering program, though it is tiny and they never have more than a few exposures' worth stockpiled away. If one of their own gets a case of Spores, they are treated like a living saint, and the faithful will seek to touch the blessed one in hopes it will rub off on them.

The law is that anyone showing signs of Spores must turn themselves in at the nearest hospital for observation and isolation. The government will then transport the victim to a bio-secure facility for observation and eventual release once it has run its course. However, if the victim has a particularly useful skill that is somehow enhanced by their Spore-given ability, the person may be offered a high-paying short-term government job as an agent for a task uniquely suited them. Some quick skin dye, a wig, shave, artificial skin or other means of covering the visible signs is used, though sometimes this is unnecessary. Either the mission does not require exposure to the public, or the external signs of Spore exposure fade once the power manifests.



## Surface Technology

The Aeth really have no concern what the lifeforms on its surface do, with one exception. The view any sort of fission, fusion or anti-matter power the same way a parent would view a wasp nest next to a baby's crib. They Aeth simply eradicate that spot. There is no warning, no negotiation, no mercy. Humanity ignored the warnings of other surface races in first centuries after the Exodus and set up an experimental fissionable isotope separator. Two million people died and a major city was reduced to rubble by having every atom of iron in the city (and its people) vanish. The entire area became a wasteland toxic to iron-reliant life, and stayed that way for exactly seventeen years, nine days, four hours and approximately eighteen minutes, after which it was perfectly safe to enter the entire area again.

As you might deduce, the surface races of Aethos do not have any form of nuclear power or weapons. Everything is done with advanced but non-nuclear technologies. Without oil reserves and only marginal coal, fuels are mostly alcohols or synthetic fuels. For the most part, electricity is used for vehicles. Aethos' suns provide sufficient light for solar power generation, and quick-charge ultra-capacitors (exocaps) are used instead of batteries in everything from scooters to aircraft. Liquid fuel vehicles are rare, but some specialized applications (high performance military aircraft) still use them.

Many of the surface races are capable of space programs, either alone or in combination with species that are physically capable of handling the same acceleration regimes and type of equipment. Because of technology limitations, surface races are limited to chemical thrusters for the boost phase, but could use ion drives for orbital maneuvering. For low-mass satellites, ground-based laser launchers are used for initial boost, but cannot get a payload into orbit by themselves due to atmospheric haze.

The problem with any sort of space program is that Aethos is usually travelling at a substantial sublight speed, and while Aethos's magnetosphere deflects most high energy charged particles from the surface, outer space is another matter. Anything above low orbit would be irradiated beyond any ability to protect against it.

Surface races have launched space stations and recon satellites during the decades Aethos spends at low velocity in a solar system, and from these the surface races have blurry maps of Aethos, but most of the time the closest any race gets to space are sub-orbital transports used between long established races friendly with distant polygons.

## Tech overview

Details will follow, but here is how the nearby surfaces races compare in terms of technology.

	Med	Wpn	Armor	Elec	Power
Terrans	Mid PA	Mid PA	Early PA	Late A	Early PA
Cartoo	Late A	Early PA	Early PA	Early PA	Late A
Tuaqq	Early PA	Early PA	Early PA	Late A	Early PA
Drinn	Early A	Early A	Late A	Late A	Late A
Ancients	Mid PA	Mid PA	Mid PA	Mid PA	Mid PA

Remember that for any aspect of technology, none can involve fission, fusion or antimatter, regardless of the tech era of other aspects of the technology. Some short-lived decay processes are apparently allowable, but nothing that has even a theoretical use as a weapon or leaves long-term radioactive toxicity is allowed. Painful trial and error has let the various races figure out where the dividing lines are.

**!** If you design your own gadgets, remember that 'energy' is really device dependent. A computer that uses 4 energy per hour is *not* using the same amount as a car that uses 4 energy per hour. The *actual* energy storage is proportional to the size of the gadget. The notion of 'powercells' only works for a limited range of gadget sizes and design parameters.



## TERRAN TECH



Humanity, like all other surface races, have stabilized at the maximum level their culture can or wishes to reach. Tech and fashion are sort of linked. The technology base has been stable for centuries, so capabilities have not changed much from your grandfather's time. However, the outward form of many things *does* change. Some fashions are fads that show up once, disappear after a few years and never return. Others make a comeback every century or two. This shows up in garments, architecture, interface design and other civilian tech. Any time a new alien race is contacted, there is a wave of alien-influenced designs, as 'the new thing' is all the rage. However, weapons, especially military ones, tend to be more standardized in terms of look and feel. There will *always* be people who want something cool-looking. But for the people whose lives depend on function more than form, certain aspects of design stay the same. A concealed weapon will probably be smooth and have no bits likely to get snagged on clothing when you draw it. A military weapon is going to have a grip and trigger guard that can be used bare-handed or in winter gloves. Sight attachment rails will be standardized so that you know the accessory you want will fit perfectly and interface with a standard plug and programming protocol.

The equivalent of USB ports has been standardized for centuries. Most portable electronic devices are self-charging, use two different radio protocols for data transfer (short range and ultra-short range), and optical fiber for secure or non-radio data transfer. There *are* specialized protocols and ports for military tech, but most civilian gear uses hardware and software that had the last of the bugs and vulnerabilities worked out of it over a century ago.

## Medicine

Terran medical technology is *mostly* based on genetically engineered organisms and therapies, stimulating the body to fix itself rather than using external mechanisms. Antibiotics, immune system boosters, cancer therapies and reversal of genetic damage are all fairly well developed, and humanity is now close to its pre-Exodus average lifespan of a bit more than a century, with a shallower dropoff than early 21st century humanity and a maximum lifespan of about a century and a half. Problems with neural degeneration have yet to be solved, and these start cropping up at about an age of one hundred and thirty years. Humans who begin to show such signs and do not want to spend their last decade as a vegetable often 'seek enlightenment', which is a nice way of saying that they tend to go someplace where the Aeth might not want them to. *And they generally do not come back.* It's a socially acceptable means of committing suicide.

In game terms, virtually any damage short of physical destruction of the brain can eventually be made whole. It is just expensive. Even damaged brain tissue can be regenerated, though any memories or skills in that damaged region remain lost unless the person had a brainsave available. However, the ability to repair neural damage of any kind becomes progressively more difficult with age and is lost entirely by an age of one hundred of twenty.





To make things simple, assume that all levels of human medical tech can eventually repair anything. The question becomes how long it takes and how much it costs.

	Rec	cost(Eur)
outpatient services	+1	-7 for one day(90)
hospital bed	+2	-3 for one day(350)
autodoc bed	+3	+1 for one day(1.4K)
intensive care	+4	+4 for one day(4K)
regen tank	+5	+7 for one day(11K)
each doubling of time		+2 cost(double)

All services have a minimum charge of a full day of services, and on-demand care (rather than by appointment) is usually double (+2 cost). So, walking into an outpatient clinic because you have an arrow in your arm will cost you double for the initial treatment.

If a service says it is 'suitable for immediate treatment', this means that this is where you should go or will be transferred to if you have that level of injury. Once you have handled a day of 'on-demand' care, you can check out of the treatment facility and use any level of medical care you want. In fact, as long as you are conscious, you can refuse any medical treatment you want. Conversely, a medical facility can refuse to treat you if they feel it is beyond their capacity to do a proper job. So, if your friends drag your burned and bleeding body to an outpatient clinic, the first thing the clinic will do is call for a medevac to the nearest regen tank, and do their best to stabilize you until a VTOL ambulance comes to whisk you away. On the other hand, if you stagger into the clinic under your own power and demand they do all treatment of your injuries, they are within their rights to simply glare at you until you pass out, and *then* call for the medevac.

! Licensed medical professionals are required to report anything that looks like a combat injury to StatePol at the time of treatment. Black market doctors do not, but you need to know how to find them and they charge double.

**outpatient:** This is like an emergency room or urgent care clinic. It can do outpatient procedures or treat anything that does not require invasive surgery, nerve repair, muscle reconstruction or plastic surgery. These clinics can do stitches, common vaccinations and anti-venoms, tendon stapling, dermal regen and other light medical tasks, Generally suitable for immediate and followup care for wounds of less than -1d effect.

**hospital:** Or a full hospital emergency room. Can do any sort of basic surgery, including bone repair, organ repair, and foreign body removal (i.e. bullets). Generally suitable for immediate treatment of crippling injuries to extremities or any wounds in the -1d level of effect. To gain the benefits on Recovery for a hospital or better, you need to be staying in the hospital, while with outpatient therapy you can maintain a very light workload and simply check in once a day for monitoring, bandage changes, adjustment of antibiotics or regen phages. At the hospital, autodoc or intensive care levels, staying in bed and doing light typing is all you can do.

**autodoc:** A misnomer, this is really just a hospital bed with computerized monitoring of drugs and recuperative phages. As an on-demand service, it can deal with most surgical tasks, including neuroregenerative ones like fixing laser-burned retinas. Generally suitable for immediate treatment of crippling injuries to anywhere except the head, or any wounds in the -2d level of effect.

**intensive care:** This is 'a dozen tubes and electrodes plugged onto and into you, with an expert computer system and a human keeping an eye on your vital signs at all times'. This is one step short of a regen tank, and can deal with any level of injury short of full-body burns, organ replacement or brain regeneration.



**regen tank:** What it sounds like. The patient is put into a sedated state or artificial coma, hooked up to a heart-lung machine and dunked into a tank of tailored regenerative phages synthesized from the patient's own stem cells. This can regrow anything, and do so amazingly quickly. Replacement of anything that is *actually* missing or destroyed will take +6 time (eight times as long) over the total required to heal the number of hits involved in that injury. Retinal damage from lasers normally counts as 1 hit of damage for purposes of being regenerated.

**i** Say you had a Recovery of +0 and lost your sight due to a laser blast to the face. A regen tank would give you an effective recovery of +5, so you would get back 1 hit each 3 hours. Fully regenerating your retinas would take eight times this, or a total of 1 day in the tank and a cost of 11,000 Eur. That is *just* for the eyes. Any other hits you might want regenerated are additional time in the tank or recovered by whatever means you want.

Implanted technology has to be removed from any injured area and replaced afterwards. The cost is high, but the effects are nearly miraculous (a person could fully recover from the effects of a gut shot with a .45 in one day).

**!** Expeditions with reasonable backing and a vehicle or two usually have the equivalent of an autodoc, with a robot arm acting either as a teleoperated surgical tool or an assistant to an on-site medical professional. This would be the equivalent of a +2 medical lab.

Any treatment short of a regen tank will leave scars, though they may be so fine as to be unnoticeable unless you are a media star and your face is 5 meters tall on a movie screen. Hospital care is sufficient to repair individual injuries to a superficially scar-free level, but regen therapy is required to overcome scars from things like whole-body burns.

## Weapons

Terran weapons are advanced conventional firearms, lasers and gauss weapons, each with advantages, disadvantages and operational limitations. In rural areas among the civilian population, the favored weapon is a self-charging laser rifle with an optical scope (filtered against the laser's wavelength!). People are generally educated enough about lasers to know the dangers of 'ricochets' (i.e. stray reflections) and not exercising proper care is the minor offense 'public discharge of a firearm', possibly aggravated if someone is injured or blinded by it. Simply being on Aethos keeps the weapon fully charged. The second most popular weapon is a 'legal weapon' equivalent of the KK-511 assault rifle. It is mechanically identical, so people can use it with their basic military training, but it uses less powerful ammunition so that it qualifies as a legal weapon. For military use, lasers are readily blocked, so gauss weapons are used for heavy infantry, crew-served or artillery-class weapons. However, these can be detected by their emissions. This is not usually a problem when dealing with weapons of this size, as their effects are pretty obvious anyway. But for clandestine or sniper use, conventional weapons are sometimes preferred.

Sidearms and concealed weapons run the range of technologies, but Terran military sidearms are gauss pistols that fire the same darts as rifles, but at lower energy. Gauss weapons require close tolerances and use very high energy electronics, two items that are difficult to reconcile with the dirt and wet and mess of the typical battlefield environment. Terran weapon designers have managed, but just barely. Terran soldiers are well trained in the care and use of their weapons, especially their use in poor conditions. Modern gauss weapons have automatic muzzle shutters, watertight electronics and elastomer seals between magazine and weapon, mechanical tolerances as loose as acceptable for a weapon of this type, and they are built of modular components that are easily swapped out in case of problem.



But it is not the sort of weaponry that can be issued to poorly trained conscripts. In the event of conscription, KK-511 assault rifles are warehoused in mass quantities, along with billions of rounds of ammo in inert atmosphere storage. Most of these weapons and much of the ammunition are leftovers from the fifth Earth-Cartoo war, but they are still just as effective and deadly, and a lot easier for less experienced troops to use and take care of.

Electrical taser-like weapons (but without the wires) are common in police use as a subdual weapon, and a similar device falls under the 'legal weapon' heading for civilian carry.

Man-portable anti-armor rockets and anti-aircraft rockets are available, and are usually fire-and-forget guidance, though Terrans and most other surface races have inexpensive unguided rockets for short range anti-vehicle use.

In terms of rule mechanics, a 'legal weapon' is one with a delivered energy of 600 Joules or less, along with some other legal parameters. But the main thing is damage, and this turns out to be:

'legal weapon'	maximum damage
conventional weapon:	2d+2 or 2d+2 stopping
laser weapon:	2d+2 stopping
gauss weapon:	3d+0 penetrating
stunner:	4d+1 non-lethal
impact stunner:	3d+2 half-lethal

! Both gauss and laser weapons in Aethos have a 'cough' mode that fires one or more times at a low damage level whenever internal diagnostics indicate a blockage or problem at the instant of firing. This may clear up minor obscurement of a laser emitter, or small amounts of water or mud in a gauss weapon. This is automatic if you fire while sensors indicate a problem and generally cannot be overridden. Attempting to clear a weapon in this way is a major action and uses 1 charge for a laser or 3 charges on a gauss weapon.

Because of the stabilization of technology and materials used to make weapons, there is a lot of fairly meaningless posturing between manufacturers of pretty much the same weapon. In the gear list, they will just be listed as 'legal weapons'. All of the possible technological refinements that can go into a legal weapon are in place. The only difference is that for any modern firearm, a full-body physical and neural scan can determine exactly which manufacturer's legal weapon is best for you, and a custom trigger pull, grip, weight distribution and the like will result in a weapon that gives you -1 to the difficulty on *any* use of the weapon (including drawing it), and an additional +1 Accuracy for aimed fire (maximum Accuracy of 3 for pistols and 5 for rifles). This process and modifications will quadruple the cost of the weapon (+4 cost level), and it takes several extra days to fabricate and ship the custom weapon. This improved Accuracy can be further enhanced by other devices, but this limit is for the bare weapon.

! If there are nearly identical weapons in a type, the gamemaster could make it interesting by randomly choosing the one that is 'best' for an adventurer, possibly giving the player the choice between one that is optimizable but not their preference, or their preference but not optimizable.

Conventional weapons are those readers are most familiar with, using high-tech gunpowder, steel and plastics, usually firing a plastic-sheathed high-density ceramic projectile. Police and military rounds usually have a solid projectile, while hunters use a pre-fragmented one designed to cause more tissue damage. Military ammunition can also have armor-piercing capability. However, only regular and pre-fragmented ammunition can be used in legal weapons.

! For gadget design, most Terran civilian items will have a tech base of 11/2 and military items will have a tech base of 12/3.



Lasers are typically in the ultraviolet part of the spectrum, using collimated arrays of semiconductor lasers, pumped by exocap discharge. The object of a laser is to have as much energy as possible absorbed by the target, so the wavelength chosen has the naturally beneficial side effect of minimal reflection off most surfaces. Even so, most laser users will wear custom sunglasses or goggles to filter out stray UV radiation, and in the worst case, retinal damage is easily repairable with Terran medical tech. Lasers have the disadvantage that the beam is scattered by anything that obscures vision. Smoke, dust, or fog will cause the beam to drop in damage by half or 2d (whichever is greater) if they have to pass through any significant visual obscurement (gamemaster can adjust as needed for specific situations). Laser weapons have no recoil and do not lose aiming bonuses between shots.

Lasers come in two varieties, pulsed and continuous beam. Pulse lasers fire packets of energy just like a gun fires bullets. Each one strikes, has its effect and is done. Continuous beam lasers are more like an extraordinarily rapid autofire. Each individual shot may be less powerful, but it is possible to pile lots of energy into the exact same spot, and because the beam is continuous, moving the beam across an area cannot help but intersect targets in that area, just like a fire hose.

Continuous beam lasers use the continuous beam notes in the **EABA** rules. This represents holding the beam in place steady enough to burn a single hole into the target. Using one of these lasers for covering fire is like applying a quantity modifier of up to +14, split as the firer desires between the chance to hit something and the damage done. Because of their indiscriminate nature, continuous beam lasers are generally not 'legal weapons'. One 'shot' for a continuous beam laser is usually one second of continuous use, and a person can usually use a fraction of a second if desired.

Gauss weapons use magnetic accelerators and exocaps to propel a small ferrous projectile at hypersonic velocity. These penetrate armor better than normal, but tend to overpenetrate and do less tissue damage than larger projectiles. Gauss weapons require a little more maintenance and care, and their inherent circuitry makes them impossible to conceal from close-range scans. Military gauss weapons fire fully armor-piercing projectiles. Artillery gauss weapons are designed to accelerate larger payloads like high explosives or terminal homing rounds, while tank weaponry tends to rely on smaller bore armor-piercing projectiles, with rapid-fire support weapons and missile launchers to handle other needs. The Terran military has a large number of wheeled, ultra-long range gauss artillery as a mobile means of hitting Cartoo targets in case of hostilities.

As a reminder of special weapon effects:

- **armor-piercing:** Reduce the armor of the target by 1d if it is equal or lower in technology than the weapon
- **stopping power:** Increase any damage that penetrates armor by +1. Net effect of +1 on unarmored targets
- **penetrating power:** Increase damage before comparing to armor by +1, but give a -2 penalty on that which penetrates armor. Net effect of -1 on unarmored targets

### Armor

Aside from the spectrum of historical materials available, there are two types of body armor in common use. The first is multiple layers of high-tensile strength fabrics, like an early 21st century bulletproof vest, but better. These can be made as vests, contoured body suits, or even as liners for normal clothing. This tech is lightweight, but has less effectiveness against blunt trauma or piercing weapons like knives. This is a flexible armor for purposes of blunt trauma or other kinetic impacts. The other is less concealable, but is made of phase-change materials that stiffen under stress.



The armor is flexible, but when struck it becomes rigid. These will incorporate a ceramic matrix to better stop penetration of projectiles, and ablative fabrics to dissipate laser energy. Their drawback is that they must be at least a few centimeters thick to be effective, making only the lightest protection concealable under clothing.

! For gadget design, this hybrid armor uses the 'protects as armor' modifier to represent its advantages.

Rigid armor like helmets are usually a resin-impregnated advanced fabric, with an inner layer of the phase-change armor, with face-plates of transparent, UV-blocking ceramic between anti-spall layers of plastic. Because of the commonality of lasers, virtually all consumer eyewear has filters to block the specific frequency bands commonly used. Military weapons can adjust their frequencies slightly to avoid a specific filter (no sense in making it easy for enemies), but these are left in the default frequency for domestic use. Lasers in the 'legal weapon' category operate on fixed frequencies that are illegal to adjust.

Military vehicles are armored according to their role. Tanks or the equivalent have composite metal-ceramic armor, with replaceable anti-laser and anti-shaped charge plates. Limits on computational power make active counter-measures hard to implement against short range weapons (they cannot respond fast enough), though anti-missile systems are common at defensive installations.

Light military vehicles will have phase-change plates between rigid layers, often with a ceramic-metal composite as the outermost layer. Hovercraft usually have carbon or other composite bodies with ceramic microbeads in the matrix, a ceramic microbead outer layer for abrasion resistance, and light armor only over key components like the crew, turbine and weapon.

! Wet navies are very limited on Aethos. None of the polygon seas are connected, and occupied ones have been mapped in great detail over the centuries. This means that surface warships are sitting ducks, any submarines have very few places to hide, and everyone has remote sonar probes and other sensors to keep track of anything of useful size. The only water-based forces that stand a chance of getting anywhere unseen are stealthed commando teams using one- or two-man submersibles.

### Electronics

Electronic and semiconductor technology is limited by unknown emissions from Aethos. Components at the density of pre-Exodus microelectronics or quantum computers are not possible. Emission spikes cause internal interference in components smaller than those created at approximately 2000CE levels. This can still be reasonably sophisticated at both a personal and institutional level (think of a first-generation iPhone), but high-definition video and terabyte storage are no longer standard features on cell phones, and low-density analog circuits are still common for many consumer-grade devices like walkie-talkies or vehicle radios. Even the exocaps used for power storage are limited to less than their theoretical maximum, but on the other hand, exocaps can be engineered to take advantage of low level Aethos emissions to self-charge. These are not quite as efficient as the normal exocaps, but are *always* ready, no matter how long they have been stored. Terrans take it for granted than an unattended electronic device is fully charged.

! For design purposes, an independent reserve that self-charges on Aethos has that race's tech base for 'power' and gets 1 energy per 15 minutes with the 'special equipment' of 'being on Aethos'. Weapons would have a discharge rate modifier of +0 and consumer devices a +4. You normally design an energy weapon as using bulky charges, and then make sure that a battery the size of the clip has about the same amount of energy as the clip size.



Other races have their own particular quirks in their electronic technology in certain subsets of function, but all are limited in the density of components relying on electron transport. For instance, the Cartoo have an advantage in bio-electronic interfaces, and can make them far more sophisticated than humans can. Whether this is a matter of industrial secrecy, some advantage that is inherent to Cartoo nervous systems regarding the interfaces or something else is for the gamemaster to decide.

The Cartoo use a 'fuzzy' technology in their cybernetics that relies on electron probability rather than binary ones and zeros, but their mainframe computers are only slightly more capable than Terran ones. The Ancients use laser-etched analog plates and sophisticated software to read them, assuring that in the worst case, an Ancient with a good optical microscope could still access their cultural knowledge. Their commonly available Ancient knowledge is stored as crystal defects in three dimensional optical media, which can be written and read from faster than Terran optical or magnetic storage media.

The maximum potential of Terran computing devices is *less* than that available to the person reading this. The earliest model iPhone would be the pinnacle of Terran electronic technology on Aethos and cost the equivalent of a month's salary for an average person. Most people with cell phones rely on much cheaper models with less than a gigabyte of memory, but touch-based interfaces are common, as they have less moving parts to wear out. A Terran cell phone has an average useful life of a decade, and its replacement may be the exact same model. People may even insist their new phone keep the battered and scuffed case of the old phone, just because it has more character. People become quite comfortable and loyal to a particular form factor and interface, and with no further advances in tech, there is no 'latest and greatest' for early adopters to acquire.

Limits on the memory density of flash memory mean that some devices will have tiny shock-rated magnetic platter storage devices, holding up to tens of gigabytes of data, which is cycled in and out of solid state memory as needed, both for energy efficiency and to protect the drive from damage from sudden movements.

E-paper is common, though the underlying technology is as expensive as any other. Pocket e-books are not unusual for college students, and can be configured with a number of subscription services, so that you always have the latest newspaper at hand, magazine subscriptions and so on. Limits to information density mean that old issues have to be deleted or archived at home, but a small e-reader can still hold several hundred texts or several hundred music files. Over the air transmission of information is at a maximum information level of +35 each second, though in rural areas this can drop to +25, coverage in alien areas of the polygon is subject to extra charges and coverage outside Earth's polygon is spotty at best.

**!** A normal CD has an information content of +53 and a DVD has an information content of +59, which means that a good Terran network connect could transmit a DVD-quality video in a time level of +24 (1 hour) or a CD-quality audio file in a time level of +19 (11 minutes). So, in well-connected areas, high-quality realtime video is not a problem if you have the money. Lower income people probably have lower data transfer rates.

A person's normal standard of living includes the most likely level of network access. Higher income has better bandwidth and coverage, lower income may be limited to government-subsidized channels, educational and news feeds.



## Power

As stated elsewhere, neither Terrans nor any other surface race have nuclear power or nuclear weapons. Everything Terrans do is with more conventional technologies. Without oil reserves and only marginal coal, fuels are mostly alcohols or synthetic fuels. For the most part, electricity is used for motive transport. Aethos' suns provide sufficient light for solar power, especially since there is no 'night', and high density ultracapacitors (exocaps) are used instead of batteries in vehicles from scooters to aircraft. Liquid fuel vehicles are rare, but specialized applications (high performance military aircraft) still use them.

Exocaps in Terran use are derived from Tuqq technology, and in one of the few instances of cross-race industrial standards, both use the same size and type of exocaps in most applications. Exocaps have the rapid charging capability of capacitors, and the energy storage of advanced chemical batteries, in a package whose density is somewhere between the two. Since electricity can be generated and transmitted anywhere within a technological society, electricity is effectively 'fuel', and exocaps are the 'gas tank'. Exocaps can be used in everything from wristwatches to cars to laser rifles, and ones that take advantage of Aethos natural energy fluctuations to self-charge are the norm, meaning every electrical device that uses them is self-charging.

Most low-power Terran electronic devices can operate continuously off this low-level recharge, and ones with intermittent higher power use have their normal run time greatly extended. A human would be shocked if a flashlight that had been sitting in their automobile trunk for ten years failed to work, if their cell phone did not run on standby indefinitely, or if their electric car did not get back some of its capacity in the parking lot during an average workday. Energy-intensive devices like lasers can easily run out, but for occasional use they easily stay fully charged.

## Other

Terrans and virtually *all* races operating at an Early Post-Atomic level for civilian goods have Makers, three-dimensional personal printers capable of making most forms of monolithic goods. Plastics, metals, fabrics, ceramics, all can be custom fabricated. Not everyone has a Maker, but every community will have several in commercial use. A clothing shop can make clothes just for you. Specialized Makers can print replacement skin and muscle (or a steak), and licensed downloads of popular items are a source of income for artists.

## CARTOO TECH

The Cartoo are more likely to dabble with other races' tech, if only to give them an edge or temporary advantage against foes both external and internal, but they do have their own comfortable level of indigenous technology and standards.



## Medicine

Cartoo are less capable than Terrans when it comes to life extension, genetic repair or regeneration of lost body parts. Part of this is cultural, part of this is technological and part is a subtle difference in biology that makes them harder to work on in this way. Even Terran techniques do not work as well on the Cartoo as they do on humans. However, the Cartoo are well ahead of humans when it comes to interfacing electronic devices to biological systems. They are quite capable of two-way transmission of data and sensory information between themselves and their electronics, and while they could transfer information between individuals using intermediate devices, they have a cultural antipathy about that level of sharing, even if it would be more efficient or tactically desirable.



## Weapons

Cartoo soldiers are generally not as well trained as Terrans, though their elite units are at least the equal to their Terran counterparts. Cartoo infantry tend to use conventional firearms. Individual Cartoo use whatever suits them best. Cartoo armored vehicles are a semi-elite group and use binary-propellant cannon, and a mix of projectile types, with secondary armament varying with the expected deployment. The Cartoo talent for cybernetic modification makes it more likely that a Cartoo can interface directly with their weapon, giving them numerous firing advantages like seeing through a weapon scope to let them fire around corners. These augmentations are not likely to be found in average soldiers, however.

**!** In game terms, Terran weapon enhancements do anything that Cartoo weapon enhancements can, but the Cartoo can do them faster. Being able to think a command to a weapon is faster than pulling a trigger, being able to see sensor data directly in your mind is more efficient than having to look at a display screen, and so on. In general, an augmented Cartoo with a ranged weapon will be at +1 to normal initiative at no penalty. This assumes the Cartoo is doing this augmented action as their first action.

## Armor

Cartoo armor is much the same as Terran armor, both for personal and vehicle use. Cartoo tend to use less body armor for extremities and more for core areas, and their armor is designed mostly for stopping projectile attacks. Compared to Terran military armors, you can drop 0d+2 or 1d+1 from the extremities and add 0d+1 or 0d+2 to the head and torso.

## Electronics

Cartoo computers are slightly more capable than Terran ones due mostly to computer architecture rather than an inherent advantage in materials and fabrication. Cartoo electronics designed for export have sometimes been found with program back doors and remote deactivation or monitoring capability, so no one with any sense uses Cartoo devices in critical applications. Even Cartoo are distrustful of devices made by Cartoo clans other than their own. The only commonality between Cartoo devices is a racial mandate that they use compatible power sources, certain mechanical standards like bolt sizes or ammunition and clip types, and run at least a certain subset of a Cartoo-standard programming language.

Other than that, individual Cartoo clans make devices specifically for themselves. Smaller groups may buy the basics from larger one, but if possible, they prefer to manufacture their own mission-critical components. Surprisingly, there is actually trade between Earth and some of the smaller Cartoo clans in Terran off-the-shelf tech, as it is known that Terran consumer electronics is usually 'clean' in terms of malware or compromised hardware.

## Power

Cartoo use exocaps and other standard means of generating and storing power, though their exocaps lag behind Terran ones. This is mostly due to a shortage of rare elements needed. They have gone through their own supply, and rather than show weakness by importing a strategic material, they simply use a slightly less advanced exocap design. They are as a race and also as individual clans, always on the lookout for large quantities of key elements, and this is always a planning item for any conquest of new territory.





## DRINN TECH

The Drinn have been on Aethos for several thousand years and have settled on a level of technology that both suits them and is readily sustainable on Aethos.



### Medicine

Drinn are natural regenerators. In addition to being able to eventually regenerate lost limbs, their organ structure is distributed as well, with small organs of identical function near the base of each limb. A lot of Drinn trauma medicine consists of a tourniquet and a surgical saw, cutting off the damaged part cleanly so it will grow back better.

Drinn are fairly hard to kill. Natural deaths are due to disease or infection because of a gradual weakening of the regenerative and immune systems as they reach old age, which for a Drinn is in their nineties. Drinn medicine is mostly the preventive kind, like vaccinations, and trauma care, like that needed to keep a Drinn from bleeding out due to circulatory system damage. Drinn science has extended their natural lifespan by a few decades, but despite being natural regenerators, they have not found a way to perpetuate the process.

### Weapons

Drinn weaponry is fairly simple. They use minimal amounts of metal and a fair amount of advanced ceramics in their weapons, but the net effectiveness is not any better than late 20th century Old Earth technology. Drinn infantry use conventional weapons of fairly large size and power, along with grenade launchers and unguided high-velocity rockets. AFV and aircraft armament is much the same, relying on specializations in pilot and gunner skill rather than computer augmentation. Recognizing the military limits of their tech, Drinn military hardware is designed to be stealthy, relying on materials and design to be hard to spot, track or lock onto with advanced sensor systems.

### Armor

Drinn armor is generally ceramic-based, using a gradated plate with varying hardness and ductility, depending on the application. Drinn vehicle armor tends to be of compositions that behave more like metals, with an ability to absorb energy without major structural failure, while their personal armor tends to have numerous pieces that are exceptionally hard, but which absorb energy by fracturing, so they have to be replaced. The Drinn are also adept at using the cellular structure of alltree wood as the basis for armor and structural materials, perfusing the wood with high-strength resins, freeze-drying the wood and using the cellular scaffolding for growing ceramic lattices, and so on.

### Electronics

The Drinn are not wedded to high-tech electronics. By and large, they use only analog devices with fairly complex self-balancing circuits. Even their equivalent of flat-panel displays use analog circuits, using magnetically mutable fluids of different colors. While all of this significantly limits the bandwidth of their communications, they have yet to experience a major communication blackout due to the vagaries of Aethos' operation. Drinn data storage is mostly in the form of old-fashioned libraries, manually indexed and with a trained staff to help a user find what they are looking for. Printed copies of information can be scanned and transmitted through telephone lines, to be printed in slightly degraded form at the other end of the line. Their equivalent of electronic storage is a magnetically rewriteable optical medium which can store the visual equivalent of sound patterns for later playback or pinhead-sized high-res photos which can be magnified and projected onto a display screen. Both of these are very low density storage compared to Terran devices, but Drinn consider them sufficient for their needs.



## Power

The Drinn use solar power for most of their electricity needs, with a few large banks of imported self-charging exocaps for power-critical installations. Most of their civilian infrastructure relies on wired power, and they have a fairly thorough rail system powered almost entirely by electricity. Drinn do not use exocaps for military vehicle power, relying on plantation-grown alltree oil and conventional piston or turbine engines for long range transports, and chemical batteries or energy-storing flywheels for short range vehicles. For instance, urban transport is usually by fly-wheel-powered bus, with automatic recharging at each bus stop. Alone among the races in this polygon, the Drinn have a major investment in wind turbines, taking advantage of Aethos' predictable weather patterns to augment their solar arrays.

## TUAQQ TECH

The Tuaqq are on about the same level as humanity in most types of technology. They have been on Aethos about two thousand years and have reached a level of resource scarcity that requires them to look more seriously at recycling and alternate materials than they used to.



## Medicine

The Tuaqq are not as medically advanced as humans. Partly, there is a greater resistance of Tuaqq biology to techniques that humans use to good effect, and partly due to the lesser cultural value placed on Tuaqq males and pre-sentient children. However, they are still quite competent at the mechanical aspects of medicine like critical trauma care and reconstructive surgery, and systemic things like advanced drugs. What they lack is regeneration, especially of nervous system tissue, advanced cloning and genetic therapies. In terms of lifespan and age-related changes, they are close to early 21st century human norms.

## Weapons

Tuaqq have formidable natural weaponry, and they typically do not enhance these with any sort of metal edges or extensions. Only members of the soldier class normally keep their claws sharpened. Socially speaking, sharp claws are like a human walking around with a pair of fighting knives in his hands. *You better have a good reason for it.*

The Tuaqq as a culture prefer laser weapons, but their body structure and their genetic tendencies predispose them to melee combat. These two generally do not mix, but it means that if you encounter a hostile Tuaqq, you are either going to get burned or sliced. Their heaviest weapon is a laser-pumped plasma, firing a hellishly hot ball lightning that either splashes against armor and leaves a small crater, or perforates the armor and detonates on the other side. This weapon is only on vehicles and thus far has not been scalable down to personal weaponry. It is technically self-charging in the Aethos environment, but a weapon station will usually have a direct link to the vehicle power plant. On vehicles without sufficient power to run the weapon, replaceable clips are used. A Tuaqq plasma weapon has numerous side effects, like a very high visual, acoustic and energy signature, and usually requires a gun shield to protect the skin and vision of the firer from flash burns.

! A Tuaqq plasma weapon is designed using the 'battering damage' modifier in **EABA**. The weapon has less damage for purposes of armor penetration, but gets +2 damage on whatever penetrates armor for each die in the weapon, not just the dice that penetrate armor. That is, a 3d+0 battering weapon hitting a 2d+0 armor will do 1d+6 damage (1d that penetrated armor and +6 for the battering effect).



Tuaqq military hardware is fairly complex and based on smart devices and mesh networks. Any given Tuaqq military formation tends to act like a single large organism, each part of it constantly aware of what other parts are doing and acting accordingly. The Tuaqq are very fond of laser weaponry. They are aware of its limitations and that other races know these limitations, but they use them as primary armament anyway because it makes their logistics a matter of energy, not physical ammunition. Most of their laser weapons are modular, allowing customization for particular tasks, like heavier emitters for better armor penetration at the cost of reduced clip capacity, autonomous tracking mounts for sentry duty, etc.

For secondary weaponry, Tuaqq use smart weapons, things like variable ballistic grenade launchers, adaptive near-intelligent minefields, autonomous weapon drones and the like.

### **Armor**

Tuaqq have tougher skin than humans, but this is not something that will stop modern weapons. Tuaqq infantry generally wear very light armor. They are males and while not considered expendable, the effort going into protecting them is an investment to make sure the weapons they are issued are able to be used to good effect. That is, the expensive Tuaqq battle rifle is no good if the Tuaqq holding it is dead.

Ironically, Tuaqq personal and vehicle armor has no enhanced protection against lasers or plasma. Rather, they have settled on a layered composite of steel and ceramic that has a good effect against most types of weapon, at the cost of being metal-intensive and fairly heavy (about 1d less capable than human equivalents). However, the Tuaqq army is a standing army and mostly a defensive army. When a vehicle wears out, it is simply melted down for scrap and rebuilt with very little loss except the energy cost, which with solar power, is no drain on the Tuaqq.

### **Electronics**

The Tuaqq have electronics tech comparable to Terrans, or more accurately, Terran electronics is derived from Tuaqq electronics. The Tuaqq are extremely well-connected electronically, using short range wireless and long range wired connections to keep their nation aware of what is going on everywhere, all the time. Electronics are proportionately as expensive for Tuaqq as Terran electronics are for humans, but no Tuaqq would be caught dead without a device whose name translates as 'universal'. This is a small Tuaqq device that handles the function of phone, light-duty computer and entertainment device, with the ability to also be a secure financial terminal, voting booth, video camera and mapping device, about the same as a full-featured smartphone from the very early 21st century on Old Earth. It is bigger than something like an iPhone because of the extra hardware, but Tuaqq do not mind. Because they use clawtips for tapping, most Tuaqq keyboard-equivalents are recessed and difficult for humans to use without special artificial clawtips or hunt-and-peck with a stylus.

### **Power**

Tuaqq generate electrical power much the same as humans, and the exocap technology humans use is a minor tweak on Tuaqq technology. Of the standard size exocaps in use between the two cultures, Tuaqq have a few sizes larger than the standard Terran commercial varieties, mostly for use in heavy infantry lasers, but other than that, Tuaqq exocaps can be used in Terran devices and vice versa.



## Space travel

Many of the surface races are capable of space programs, either alone or in combination with species that are physically capable of handling the same acceleration regimes and type of equipment. Because of technology limitations, surface races are limited to chemical thrusters for the boost phase, but could use ion drives for orbital maneuvering.

The problem with any sort of space program is that Aethos is usually travelling at a substantial sublight speed, and while Aethos' magnetosphere deflects most high energy charged particles so they never reach the surface, orbital space is another matter. Anything above low orbit would be irradiated beyond any ability to protect against it.

Surface races have launched space stations and recon satellites during the decades Aethos spends at low velocity in a solar system, and from these the surface races have passable maps of Aethos, but most of the time the closest any race gets to space are sub-orbital transports used between long established races friendly with distant polygons. Surface data is considered very proprietary, so while the various races have probably mapped a lot of Aethos, none of them have more than a piece of the whole map and few are willing to share their piece. So, places like the Lost Colony still have places to be hidden from Terran view.

At the start of a campaign, most races with sub-orbital capacity have grounded their fleets, and will not resume service for a few months. This delay in service to distant locations could be a backdrop for an adventure, especially if the two areas had been cut off from radio communication as well.

## Esoteric gear

While many items can be described adequately as a set of stats, here is some more detailed info on a few items for the various races in this polygon.

**brainsave:** This is a socially controversial technology that in a violent world is likely to be more important to adventurers than the average person. It is not an easy or cheap process, but it does allow the information content of a person's mind to be saved and restored in the event of a traumatic brain injury.

The process goes something like this. First, a nearly nanoscale sensor harness is woven across the surface of the brain and infiltrated into the major sensory pathways and the left-right hemisphere crossing. This requires that the top of your skull be removed and the entire process is done while you are awake in a regen tank, just to make sure each aspect is properly calibrated. People who cannot take 2's on a difficulty 5 Will check need not apply, as you will decide the process is *not* for you after seeing the video of this step. This process ends with you having a small data socket under the skin behind one ear. It is not *actually* necessary, but there is a general hesitation about making the data transfer a wireless process that could be intercepted or interfered with.

Then, a full-size cloned brain is force-grown from your tissues and given an identical sensor mesh, along with calibrated outputs for the spine and sensory paths. The brain is kept in an informationally-malleable state, attempting to mimic the stages in life when it is most receptive to change and being changed.



Then, a transfer of information from your brain to the cloned brain is done. This requires a rather powerful intermediary computer and a forced comatose state. The computer 'pings' your mind in a pattern unique to your sensor harness, records your responses and then stimulates the neurons in the cloned mind until it generates a matching signal. The process takes about a day and is not perfect. However, human memory is *not* like that of a computer. We remember things multiple times in different ways. We can remember a song by hearing its opening lyrics again, even if we could not have voluntarily recalled it otherwise. A place, a smell or a circumstance could also bring that song back to mind. So, even if the transfer is not perfect, it is 'good enough'.

Now, this leaves you with a cloned brain that has your memories (and skills) imprinted on it. You have to keep this brain alive for it to be of any use, which is a constant expense. But what this *does* give you is an insurance policy. If you go out on an adventure and come back missing your head, a new one can be grown for you in a regen tank and the backup brain installed. You will be alive again, but with no memories (or XP gains) for the time since that backup was made.

**!** It may be difficult for a player to 'not remember' what their adventurer knows, but it is pretty easy to remember that if you need to be brought back from the dead this way, any experience you gained in the interim is lost.

You can have regular backups made, but the brain is *not* meant for total wipes and rewrites. The process does not allow for an 'incremental backup'. You have to erase *all* the patterns and rewrite the *whole* thing. In game terms, each backup *after* the first on the same cloned brain is going to cost you a cumulative 1S penalty off your most costly skill or skills. The things that require the most precision start to get a little blurry in terms of their recall.

You can theoretically take a stored clone brain and use it to make a copy of itself, but in practice this does not work as well as it should. The cloned brain benefits from being in a body, from having real sensory inputs and new memories being added to reinforce the synthetic ones forced upon it. So, facilities will generally not make a copy of a cloned mind and this is part of the contract for the service, along with a whole lot of legalese to cover the facility's butt in case there are any problems.

Other game stats of note are these: The initial surgery, cloned brain and scan costs 100,000 Eur and 1S. If you have it at the start of play, the 1S is usually through a Favor, the details of which are up to the gamemaster. Keeping a cloned brain in a secure facility with 24/7 life-support costs about 25,000 Eur per year, and generating a fresh cloned brain also costs about 25,000 Eur. Updating a saved brainstate costs about 10,000 Eur and takes a few days. Installing a cloned brain takes as much time and therefore cost, as it would take to recover 8 lethal hits in a regen tank, plus additional cost for transporting the brain from storage to the regen facility (normally billed at 1,000 Eur per hour).

So, with a startup cost of 100,000 Eur and a yearly maintenance cost of 25,000 Eur (plus 10,000 Eur if you do a yearly backup), this is not the sort of thing average people can afford without quickly bankrupting their government-sponsored lifetime medical benefits. However, there are plenty of people who *can* afford this, and among some it is a status symbol. Current members of the Legislat, Supreme Adjudicaat and the Executive all have given themselves this perk. Generals and agency heads have it, and outside the government, industrialists, entertainers, famous daredevils, sports figures and such may cough up the money for the process. For a while, there was even a situation comedy whose plot revolved around the implausible antics of heads in jars.



On a more serious note, the idea of brainsave has some technological, legal, ethical and faith-based problems that rise and fall from prominence depending on the current makeup of the government.

**technological:** The brainsave process is done the way it is done because emanations and energy spikes from inside Aethos make reliable quantum-level scans and recording impossible. If this had been Old Earth, the tech would have been implemented in zero-interference chambers and simply recorded the actual physical interconnections of the brain, which would be later regrown using a specialized biofabricator (3D brain printer!). Even with the more cumbersome tech that Terrans now use, the fact that Aethos is now maneuvering and has fired up the dark matter drive may cause problems. There may be periods of weeks, months or even years in which new brainsaves cannot be recorded. Existing clone brains retain their knowledge and can be used, but new scans can be arbitrarily put on hold by the gamemaster if useful for dramatic purposes.

Attempts have been made to give cloned brains artificial sensory input and/or synthetic worlds in which to exist in a conscious state. *These have uniformly resulted in insanity.* Current legal prohibitions on these processes make further research on why this happens next to impossible.

**legal:** Brainsaves open a whole new legal can of worms regarding life, death and identity. If it has not already occurred to you, consider a case like this: a) You get a brainsave. b) You wait a few months. c) You kill someone and then kill yourself. Now, if you are brought back from state a), can you be tried for the murder? After all, the 'you' that exists now has no memory of having done the crime. From *your* perspective, you are genuinely innocent of wrongdoing. The prosecution would need to prove that you had already planned the murder before the brainsave and that you were using the brainsave as an alibi.

Or, what is your legal status between when you get your brains splattered and your cloned brain installed? Are you alive or dead for legal purposes? What rights do you retain? What if a witness to a crime is murdered, and their memory of the crime has been saved? Is it legally the same person? Can the state force the mind into a new body to testify even if the person did not want to be brought back at this time? Are you guilty of negligence if you mishandle a body that has a saved brain, since this would add to the cost of regenerative therapy? If you are dead but have the money to keep a cloned brain alive, but not enough to have a body grown for it, what is your legal status?

**ethical:** By those who cannot afford it, the brainsave process is seen as a form of class warfare. Soldiers die, generals live. Average people die in accidents, the rich and famous get new bodies and cloned minds. The process can also be used to put an old brain in a young body. This is not quite the immortality you would think, since the neural failings of an ancient brain are partially the dead weight of too many memories and partially the slow biological decline of that ancient brain. You cannot do a brainsave from an old brain to a young brain. The cloned brain has to be aged to at least something close to the original for the transfer to work at all. So, while you can gain a few years of 'brain youth' by finessing the process, this is offset by the muddling of so much information jumbled across a century or more of memories. Eventually, you end up with the tragedy of twenty-five year old in perfect health, but who is so senile they cannot figure out how to dress themselves in the morning.

Brainsaves have also been used as a last resort of the rich and extremely elderly, the ideo being that *eventually* someone will figure out how to fix the problem, and when they do, this person will have a cloned brain with all their old memories ready to take advantage of it.



**faith:** To anyone who holds to a conservative or orthodox faith, your identity and soul is part of being alive. Once you stop being 'alive', what is 'you' is gone, even if a body that looks and acts like you is walking around. This leads to a few ethical quandaries, since conservative and orthodox politicians *like* the perk. This leads to some ethical fudges regarding the faith in question. In general, if a brainsave can be seen as 'restoring lost function' rather than 'outright replacement', then it is allowed without being grounds for expulsion from that conservative or orthodox Custom (non-orthodox and non-conservative members of a faith generally have no problems with brainsaves). The explanation is that a person with amnesia is still the same person, and a person who has had a stroke is still the same person, so a person who is missing a portion of their memory because of a brainsave is still the same person, if that person still has enough of a brain to qualify as a person. You are simply repairing damage, or so the theological logic goes.

! Brainsave as a tech really just exists for the sake of the adventurers, but if you think about it, there are any number of plots that could involve the technology directly or indirectly. An assassin for organized crime agrees to be executed after each hit, and is restored having no memory of the crime or who ordered it. A wealthy industrialist or ancient patriarch from a previous century has made provision to be brought back for a few final years as the Approach commences. Strange emanations from Aethos are causing aberrant behavior in people using the service. Those assigning religious significance to the Aeth see this behavior as sign of divine favor or demonic possession. Someone with some very important secrets has their cloned brain stolen. Hooking it up to artificial inputs will drive it insane, but as long as the secrets can be extracted, who cares? Someone who recently took advantage of their cloned brain finds a message left to themselves, intimating that their death was not an accident and that the killers might want to get rid of the new mind before a new backup is made...

**pusher balls:** The Stritt (extinct) at one point had the ability to create a form of antigravity. However, it was extremely intense, almost like a reverse black hole, which made it impractical as a thrust or mobility tool. That is, it was a field effect, and the field was so strong that it would tear apart the device generating the field in less than a second. The Terran military has managed to duplicate the tech in 'pusher balls', which are considered a military secret and are *not* available on the civilian market. A pusher ball ranges in size from a softball to a basketball in size. When activated, for about one second it generates an anti-gravity field of intense strength and *very* steep gradient. After about a second, it begins to disintegrate and shuts itself off before completely fragmenting. Pusher balls are used to cushion impacts. If timed just right, a person could fall from any height, and the increasing anti-gravity gradient of a pusher ball several meters below them would stop them at zero velocity right at ground level. A large pusher ball could do the same thing for an armored vehicle. It takes a fair amount of training (and faith in technology) to hit the ground like this. It also takes quite a bit of money. They are not cheap.

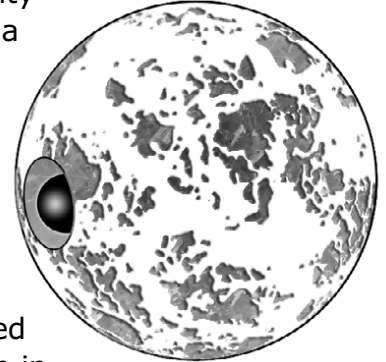

! For reference, going from a free-fall speed of around 100 meters per second to zero in the space of 10 meters would be an acceleration of 200g, which is not normally survivable, but the pusher ball field affects items as a whole, so no part of the item experiences a different gravity than the rest. However, you want to experience the gradient as uniformly as possible. Hitting the field flat on to the front of your body is good. Hitting it head first or feet first is a good way to have your head or feet crammed into your chest cavity.



It is difficult to use pusher balls as a defensive device. Trying to time one to stop a bullet would be difficult. Pusher balls could be used to deliberately generate a fragmentation effect or to breach barriers, but they would be several hundred times the cost of an equivalent explosive device.

! Pusher balls are a perfect trick for a gamemaster to use for a villain getaway. The assassin leaps from the 113th floor balcony and plummets to the street, but instead of a splat, they get up, dust themselves off, hop into a waiting car and zoom away.

**flysuits:** Essentially a jetpack, with emphasis on 'jet'. A small turbojet with afterburner is worn on the back, and a set of stubby wings protrudes from it. Combined with a specially designed flight suit, it lets a person fly like a superhero for distances of up to a few hundred kilometers. Manueverability is limited and landings are normally done with a parachute. Easy vertical landings are simply *not* possible, though vertical takeoffs can be done with the afterburner and a reckless disregard for your immediate surroundings.

Flysuits are available to civilian daredevils, but there are probably not more than a dozen of them in civilian hands and perhaps double that as a covert military asset (with stealth coatings). Because of this, they are ludicrously expensive for their size and limited utility (100K Eur).

! The infrared signature of the turbojet would be impossible to mask. For any sort of covert entry you would have to turn off the turbojet at a safe distance and glide in, with a horizontal range of about 6 kilometers for each kilometer of altitude (plus whatever altitude you need leftover for the parachute).

**slots:** Humans on Aeth do not have a lot of cybertech, but are pretty advanced with biology and neurology. A 'slot' is a temporary skill, the ability to have just about any form of physical or mental knowledge 'implanted' on short notice. It uses a variant of the brainsave tech.

The way it works is that a person learns, under brainwave and brain activity supervision, a special but completely useless skill, either physical or mental in nature (you have to choose between a physical or mental slot). This could be a nonsense language, an exercise routine, or something similar, and is called a 'slot skill'. This must be learned to at least a +0d level (or +1d if you want to slot an Enhanced skill). By the time this is done, a full record of how and where the skill is stored in the brain of that person is known. Then, someone who knows the desired skill can have the same regions of their brain mapped and recorded, and the results electrically imprinted on top of the slot skill. When the process is done, the person now has full, instinctive use of the new skill, and they would use it using the same level of proficiency as their slot skill (normally +0d). It is possible to have multiple slots or slots that have higher capability. You have to have spent the time to accumulate the slot skill or skills at the level desired.

The imprinting is temporary. After a few weeks it starts to fade and within a month it has reverted to the slot skill. A person gains no experience in the skill that has been imprinted, *if that experience is gained during the useful life of the imprint*. The experience is stored in the same brain regions the skill is fading from. Facts and figures may remain, but there is no improvement in the *actual* skill level.





Because of the time and expense, slots are limited. Executives and high-level diplomats may have them. It is a fast way to pick up a useful level of an area knowledge, language, weapon or vehicle skill. Spies and special military operatives may have them as well. The most important thing to remember about slots is that they are useless to a person unless they also have the full brain mapping data. You cannot go to a third party and get a slot filled if you do not have a copy of *your* brain map. Civilians might not have a problem, but military or government employees with slots might find that their brain mapping data is 'government property'.

**scarth dust:** Severe impacts on the northern ablation shield can not only gouge scarth, they can pulverize it. Dirt from the ejecta region of such impacts can be sifted for scarth dust. The dust has about half the value of splinters or small pieces, but is prized as an abrasive, and with proper filtering, it can be recovered and reused nearly indefinitely. Scarth dust can with some difficulty be plated onto or chemically adhered to most surfaces, or added into alloys. It does not actually react with the material it is bonded to, but is merely a mechanical mixture. Scarth-plated or scarth-infused weapons count as armor-piercing against all known defenses except scarth-plated defenses, which are +1 and fully hardened against all attacks. However, at 500 Eur per gram, it is a lot cheaper to plate a blade than it is to plate an armor. It would take about a gram of scarth dust to plate the edge of a knife blade, and probably the same amount of money to do the forming and original sharpening of the blade. It would take several tens of grams to plate something like a torso body armor.

! Scarth dust *cannot* be used to make things like super-strong rope. The dust is merely a additive, not a single chain of unbroken scarth. A scarth-infused rope would be +1 harder to cut, but would not hold any extra weight.

**monkey:** A monkey (as in 'monkey on your back') is a Terran genengineered life support system, designed for extreme environments or mission-critical human endeavor. It is a blood filter, energy supply, oxygenator and immune system booster and that plugs into the wearer's neck veins, either through a large IV line or an implanted port. Monkeys are designed to be disposable. Once decanted from a state of near-freezing suspended animation, they are good for a only few weeks, consuming themselves to support their wearer. A monkey gives its wearer a boost of +1d to their Health and Will for all purposes, so the monkey helps you run faster, tire slower, withstand pain better and need to sleep less. After each three days, the bonus provided drops by 1, so after nine days, the monkey has died and shuts down its connection to the wearer to prevent any problems this would cause.

In addition, in water sufficiently oxygenated to support fish, a monkey can extract enough oxygen to keep a person alive, but not enough to allow recovery of lost Hits from exertion. At high altitudes, it can likewise sustain a person at levels beyond normal human endurance.

There is no long-term downside to using a monkey except for a chance of infection at the connection between monkey and wearer. At 4,000 Eur (+1,500 Eur for a self-powered storage unit), monkeys are too expensive for casual use, but *are* commercially available. A fresh unit is good for the listed time, but loses a day of use for each three months of cold storage after creation). Military-grade monkeys are rumored to let the user avoid the need to sleep and depending on who you talk to, can vampirically recharge themselves off of fresh human blood, be used to flood a wearer with mind-altering chemicals as an interrogation tool, interface with the nervous system to provide extra sensory capabilities or provide telepathy-like communication or mind-reading on anyone else using a monkey. Whether or not any of these are true or merely rumor or propaganda is anyone's guess.



**body armor:** Body armor is regularly worn by police, soliders, the wealthy, diplomats and smart adventurers. The ability of modern flexible armor to become rigid on impact means that tailored body armor can be reasonably concealable and still provide good protection against the point trauma of bullet strikes or other impacts. There is one big logical assumption to be made from this. Anyone remotely competent who has time to aim, will aim for body parts that are less likely to be armored. If you want to incapacitate someone, you aim for extremities. If you want to kill, you aim for an unarmored head. How likely enemies are going to be making head shots on adventurers is up to the gamemaster, but we do not recommend it. *However, if groups of adventurers make a habit of doing this to their foes...* Additionally, most brawlers or other melee types will do the same thing. Punching a suit of shear-thickening body armor is not like punching an early 21st century Kevlar vest. It is more like punching an early 21st century Kevlar vest that is protecting a brick wall. *Not good for your knuckles.*

Remember that layered armor does not directly add. You use the best armor, and half of the next best layer (rounding down). So, a 3d+0 armored jacket over a 3d+1 body armor would be 3d+1 plus 1d+1 (the smaller armor, halved), for a final armor of 4d+2 over areas protected by both.

Assisted armor is used by Terran heavy infantry and something similar is in use by the Cartoo. It is heavy body armor with an artificial musculature sufficient to offset its own weight, so it has no encumbrance penalty as long as it has power and usually gives the wearer +1 Strength as well. The Terran model uses self-charging exocaps, sufficient for about two hours heavy use per day. Troops expecting sustained action can carry an additional exocap pack for a longer duration.

Terran military helmets have full comm suites and full vision protection against most laser weapons. Military body armor is hardened against armor-piercing projectiles of Late Atomic Era or less. Military armor usually includes a small exocap pack that can be used to power an internal cooling fan, heating unit or change the overall camo scheme of the armor. Terran military armor is available through civilian channels, however, the sensitive electronics included in military helmets are not legal for civilians to own.

**envirosuit:** A multipurpose environment suit. Has a long-duration air recycler, heating and cooling systems, and sanitary connections for up to a few days duration. Can be used as a space suit, light armor, extreme hot/cold weather gear or protection against mild radiation. Any expedition to the northern latitudes of Aethos will need these. While not armored to any great degree, all key locations have shear-thickening panels and ballistic fabric to protect against punctures and blunt trauma. Normal envirosuits cannot be worn over military body armor, but special models of assisted armor are available for extreme environments. Terran envirosuits are exocap powered, and can maintain environment s upport under low levels of exertion and moderate temperatures nearly indefinitely.

**tool:** This is a standard Terran infantry tool, and getting one is a typical Terran rite of passage, a sign that you are 'growing up'. It is similar to an early 21st century multi-tool, a utility knife blade, pliers, screwdriver, saw, small flashlight and a few other functions, depending on the manufacturer. One might have a specialized wrench for use on bicycles, while another might have a crimper for blasting caps. In general, possession of one makes many tasks possible that would not be possible without it (but not as good as the actual tool for the job), and the user can usually buy one that assists in one particular task for a slightly improved chance of success over a default tool.

The most important notes on a tool are that it can be used for punch-2 lethal damage (maximum of 1d+0) and has a small self-recharging flashlight capable of providing useful light for several meters.

**biostasis tube:** This is a roughly coffin-sized box designed to fit the 95th percentile of human size variation. It is designed so that an untrained person can put a severely injured one in it to keep them alive until real medical talent and equipment can be brought to bear. Basically, you put the person in, attach a handful of sensor leads at the direction of a computerized voice, follow the instructions it gives and then close the lid. The tube diagnoses things as best it can, with the assistance of any health-related chip implants it can read data from, and then sedates the victim as deeply as possible for their condition.

In game terms it will stop further loss of hits from bleeding or internal injuries, prevent infection and reduce the need for food and water to minimal levels, levels that the tube itself can provide for up to a week from its internal reserves. Anything a person needs to survive over time is reduced by a factor of sixteen. However, any time spent actually healing is also reduced by a factor of sixteen, since that part of the metabolic process is slowed as well.

A used-up biostasis tube can be professionally refurbished for about a quarter of its new cost, or sold to a refurbisher for about half of its new cost.

One or two biostasis tubes are common gear for expeditions going far from civilization, but not so far as to be beyond the reach of medevac flights. As a general note, medevac is part of the normal health care provided to all citizens, but it is billed to their lifetime benefit at the rate of 500 Eur per hour of transit time for medevac on Earth (from liftoff to the aircraft's return to point of origin), 1,000 Eur per hour for adjacent friendly (civilized) territory, 2,000 Eur per hour for empty polygons and 5,000 Eur per hour for any transit to and from suborbital-capable airfields.

**regen tank:** This is a field hospital unit, which can only be operated successfully by doctors or specialized techs. It is a fully immersive unit that keeps the patient in a non-aware, dream-like state and can maintain this state almost indefinitely. While in the tank, the patient's Recovery is increased by +4, and with a doctor's supervision, new limbs can be regenerated from surgically prepared stumps, or organs grown in place from cultured stem cells. Because of the expense of using a regen tank, most patients will have clauses in their medical files about the extent they need to have recovered before being removed to recover under more conventional medical care.

Damage that is healed in a regen tank leaves no scars. Damage that only starts to heal in a regen tank will leave scars, but far less than would happen without the regen therapy. It is not quite as fast as a regen tank found at a major hospital, but it can do all the same things.

The *actual* cost of operating a full regen tank or a unit like this is only about 5,500 Eur per day (mostly as specialized supplies), but the rest of the cost is amortizing the cost of the unit and paying the medical staff to operate, oversee and maintain it.



**field medkit:** This is *not* a department or camping store 'first aid kit'. This is one level below a paramedic's field bag, carrying the essentials for immediate care of punctures, cuts, shock and burns. It includes hemostatic sponges and gauzes, antibiotic, antiviral and anesthetic sprays and injectors, anti-shock drugs, a small amount of synthetic blood plasma, splints, airway tools, an oxygen concentrator mask, a minimal capability defibrillator and a basic metabolic scanner that provides heart rate, respiration, blood oxygen, and blood pressure readings. In game terms it is worth a -2 to the difficulty of any first aid or critical care task, -4 if used by someone with medical training, and a +1 to Recovery for one day for each of punctures/lacerations, burns, toxins and breaks, if used by someone with at least a +0d skill in paramedic or medicine (it has limited amounts of the necessary consumable supplies). Extra supplies can be bought to extend its use, or you could short one of the recovery types to give a different type an extra duration.

**plastiskin kit:** An adjunct to a field medkit, this is a sealed packet of bioactive adhesives and immune-neutral synthetic tissues. It can be applied to a cut, tear or other large *superficial* tissue breach and will immediately cover it, acting like new skin and counting as healing 1 hit of damage per separate injury. However, the effect is superficial and only somewhat cosmetic. The healing will not be undone by light or even medium activity, but the injury only *counts* as healed for purposes of penalties on actions. The actual damage is still there and must be healed by other means. The time necessary for healing is based on the injury without the benefits of the plastiskin.

**i** If you were barely at a -1d injury penalty and slapped some plastiskin over the wound, it would negate 1 hit of damage and put you back at no penalty. But for counting the *actual* hits you have taken, the injury is still there.

**diagnostic scanner:** This is really just a specialized cradle that is compatible with a large number of smartphones. It provides basic medical readouts for one or more races, can do common blood tests, and comes with a handful of wireless sensors that recharge in small sockets in the scanner itself. It provides a -2 to the difficulty of diagnosing any non-obvious medical problem and would be considered a useful tool for any medical professional to have in their bag, as common as a stethoscope would have been back in the primitive days of Old Earth.

**sensor bed:** This would be an order of magnitude more useful than a diagnostic scanner. In addition to basic metabolic data, it can do full-body ultrasound scanning, nerve pathway diagnostics, gas chromatography of exhaled gases and so on. The sensor bed is a box full of circuitry plus a thick but foldable foam pad full of sensors. The whole thing fits into its own wheeled suitcase for easy transport. Hospital versions have more invasive sensors to detail blood chemistry, have magnetic resonance imagers and other fancy bits, but otherwise operate the same way. A sensor bed provides a -4 to the difficulty of diagnosing any non-obvious medical problem, and is useful for the continuing care of seriously injured patients. Even a minimal budget colony would want to have one, probably hooked to a computer with a full medical database to best interpret the results. If possible, they would also have a military surplus teleoperated surgical bot, capable of performing specialized or difficult operations under control of a distant surgeon via long-range radio link.



**questionable tools:** This is not on the gear list, and just covers all the things people can have that are suspicious, but not necessarily illegal to possess unless you are caught with them while committing a crime. This includes things like:

- lockpicks or other surreptitious entry tools
- eavesdropping devices
- any sort of signal jammer
- devices for decrypting secure communications
- drugs with questionable effects

Countermeasures to questionable tools are not as suspicious. A high-security lock is no big deal. A pink noise generator to block eavesdropping is common for people in business negotiations, as are encrypted phones or software.

Being caught with something questionable if you are *already* doing something illegal often means an additional charge added to your crime, or an increase in its severity. Having such things found in other circumstances may raise a few eyebrows, will probably be tagged in any report made, and almost certainly will subject your identity to a little more scrutiny, but if there are no outstanding warrants and no recent crimes you might be implicated in, you keep your stuff and go on your way. It is however, the sort of thing that *will* be noticed if crimes are committed in that area shortly thereafter, where those tools would or could have been used.

## Terran weapons

Terrans are fairly old-fashioned for military hardware, preferring projectile weapons over more esoteric tech like lasers or plasma weapons. While a standard battle rifle has a fairly sophisticated computer, it also has unaugmented manual sights and every recruit knows how to use them. For that matter, every recruit is drilled with each aspect of their issue rifle randomly deactivated at some point in their training, just so they know how to diagnose problems and work around them.

**LK-720 Laser Carbine:** The Terran military experimented with laser weapons at several points in its history, but none ever replaced conventional firearms as a front-line weapon. The LK-720 is considered one of the best examples in Terran inventory, and is still held in reserve stockpiles for situations where it might be more advantageous than other weapons. LK-720's are *technically* obsolescent and can be acquired by anyone who has done their required military service. Unlike the KK-511, which can be acquired at production cost from existing stocks, the LK-720 is only available at re-acquisition cost, which is quite a bit higher. In addition, any LK-720 that is not destined for a registered border militia or external Terran colony has a key part of its internal circuitry fused so that it can only operate in a 'semi-auto' mode. That is, no matter how fast you pull the trigger, it can fire no more than 2 shots per second. In game terms, it cannot be used in autofire or auto-burst mode.



There are several notable features on the LK-720. First is the fact that you can adjust the power to any level from 0d+1 all the way to maximum damage, each -1d doubling the number of shots you can get from a clip.



Second, like most energy weapons, clips are self-recharging anywhere near the surface of Aethos, getting back about 1 shot per hour. Last, the weapon can be used as a long-range laser communicator for voice or data. The targeting sight can recognize encoded messages from other LK-720's and puts an alert message on the screen, passes the information to a linked device or whatever other action is programmed in. The sight itself can be detached and used as a standalone receiver for such transmissions and has a range of virtually any line-of-sight distance.

**GR-899 AMR:** The term AMR stands for 'anti-materiel rifle', which a few centuries before the destruction of Old Earth would have been called an anti-tank rifle. It is a specialized current-issue weapon whose exact capabilities remain somewhere in the gray area between 'unrevealed' and 'go to jail for revealing them'. Needless to say, it is not available for civilian purchase *at all*, so even if you acquire one, its original source *would* have been illegal, so even in the event *you* were not arrested, the rifle *would* be confiscated.



The GR-899 fires slugs made of tungsten alloy with embedded ablative superconductors. People call the GR-899 a 'gauss' weapon but it is *actually* a 'railgun', an entirely different technology. Regardless, it is an exceptionally powerful direct fire weapon. Not as good as a shaped charge on the end of a rocket by any means. But, it has many times the velocity of such a rocket and is several times faster than a bullet.

This gives it an accurate range measured in kilometers, and it has a computerized sight of sophistication (and classification) to match the capabilities of the weapon, making it useful against lightly armored vehicles on the ground or in the air, as well as against high-value 'materiels' like enemy officers.

**GK-762 Assault Rifle:** This is standard Terran issue for front line troops. It is the Gauss Karbiine, issue model year 762AE (after Exodus). The model has not changed in about two hundred years and still represents the best military technology available. It has a mount for several different types of sight. The default is a 4x optical sight that automatically compensates for range and angle of fire, and has a built-in laser rangefinder and motion sensor, so that if aiming at a moving target, it provides an accurate aim point based on the range and target velocity. The GK-762 has an Accuracy of 4 with the sight and 2 if using the backup manual sights. Fire modes are semi-auto, three-round burst and autofire.

Ammunition is provided in a two-part clip, one part with the exocaps and the other part with 65 rounds of 4mm gauss needles. The two parts can be separated for separate reloading and recharging, and the clips are self-charging given enough time.



GK-762s are legal for civilians to own, with the proper registration and transfer taxes. Veterans can get a discount on used models in surplus inventory, and colonists in potentially hostile areas can get a government-subsidized price, with the limit that the weapons cannot be resold.

**GG-851 Grenade Launcher:** This is a 45mm underbarrel grenade launcher designed to be used with the GK-762 rifle. It is a stubby gauss launcher with a three-round clip, firing a variety of grenade types using an exocap built into each grenade. The optical sight for the GK-762 is programmed for the flight characteristics of the GG-851 projectile types. The current inventory includes:

**frag:** Does 4d+1 lethal explosion damage. The default programming is a time delay exactly equal to the flight time to the target, with a minimum distance under which it will not fire (6 meters). This can be altered as needed.

**HEAP:** Does 9d+1 lethal damage to what it hits and 3d+1 lethal explosion to everything else. The default is impact fuzing and it has no adjustable time delay.

**riot:** Does an 5d+1 non-lethal explosion in the form of an irritant powder, which causes severe pain to mucus membranes and breathing difficulty if inhaled. In addition, it is laced with hundreds of tiny RFID tagged darts, capable of penetrating skin and embedding in clothing, allowing police to later ID individuals fleeing the scene (provided they do not dig the tags out of their skin and throw away all their clothing).

**flechette:** An oversized shotgun effect, designed with a wide horizontal dispersion. Acts like a shotgun, but against every target in a fan that broadens by 1 hex to each side for each four range steps, and which drops one of its multiple hits each four range steps.

**i** Range steps for explosions are normally 0-1m, 2-3m, 4-6m, 8-11m, 12-16m and 17-23m. This grenade would do a normal number of shotgun hits from 0-3m, one less hit from 4-11m, two less hits from 12-23m and so on, widening from 1 hex wide at 0-3 meters, 3 hexes wide at 4-11 meters and 5 hexes wide from 12-23 meters.

GG-851s are generally not available on the civilian market, but models legally acquired may be registered and sold like any other firearm.

**!** The way that 'generally not available, but legal' works is that all weapons like this have a serial number that is tracked. If the record for the weapon shows that it was not stolen from military stores, then it is presumably legal to own (with proper permits). However, someone else could get in trouble for selling it to you. For instance, a colony might have gotten permission to buy a number of GG-851's with a 'not for re-import' clause as part of the sale. If you bought it from the colony and brought it back to Earth, it would be something you *could* register and legally own, but if that was a government-sanctioned colony, someone in that colony's government will be paying whatever fine was specified for violating that clause.



**KK-511 Assault Rifle:** This is an advanced conventional assault rifle, made obsolete by the GK-762, but the design is still good and stocks are kept in reserve for use in the event conscription laws are invoked. It uses semi-caseless ammunition, a structural block of propellant in a combustible plastic casing. It fires plastic-coated ceramic penetrators from a 45 round clip and is capable of semi-auto or three-round burst fire. The KK-511 uses Terran standard accessory points, so current sights and grenade launchers can be mounted. The default sight is a 4x optical sight with a thermal vision overlay, the reticle graduated for bullet drop at different ranges, but without the advanced characteristics of the sight used on the GK-762. The KK-511 has an Accuracy of 4 with the sight and 2 without it.



The default KK-511 is electronically inert and can be operated with no electronic signature other than the standard RFID chip (which has to be pinged by an external source to register, and even then only at close range). KK-511s are available for civilian purchase under much the same guidelines as the GK-762, but are significantly cheaper. There is also a large aftermarket for customizing the KK-511 and a version using lower-power ammunition that qualifies as a legal weapon.

Both the GK-762 and KK-511 are available in 'sniper' versions with +2 Accuracy, it just that the average green soldier could not use that Accuracy to its full potential and the weapon modifications make it several times more expensive.

**KG-510 Grenade launcher:** This is a single shot 45mm conventional grenade launcher. It uses the same projectile as the GG-851 frag grenade, but with conventional propellant, and a dual impact/time delay fuze with a fixed 3 second delay. That is, it goes off if it hits something or after 3 seconds has elapsed. No other grenades are kept in inventory, but when the weapon was current issue a full spectrum of rounds was available.

KG-510s are generally not available on the civilian market, but models legally acquired may be registered and sold like any other firearm. Both the KG-510 and GG-851 can be dismantled from an assault rifle and used as a standalone grenade launcher, fired either as a pistol or from the shoulder. The lightweight grip and stock assembly adds .2kg to the weight and negligible cost.

! The RFID tags in military weapons are readily deactivated if you have the right hardware. Weapons sold to the civilian market have these chips active, and during warfare, weapons issued to troops have them deactivated.

! As a general rule, everyone in the Terran military, or for that matter, any modern military force on Aethos, has been trained how to operate and adapt to electronic-friendly and hostile battle fields. You can still use your gear at reduced capacity if the electronic sight has failed or your network has been borked or compromised.



**holdout pistol:** This is not a Terran invention by any means, merely the current Terran incarnation of it. It is a double-barreled pistol that fires special cartridges, each of which fires three bullets with a several millisecond delay. That is, it can fire two three-round bursts, and three-round bursts is the *only* thing it can fire. Using heavy-metal penetrators for extra effect, it is excellent for its size at getting through armor, but its relatively low muzzle energy means it does less tissue damage. Because of its semi-armor piercing nature and autoburst capability, these are not 'legal weapons' that can be carried anywhere by anyone, but with the proper RFID chip and permits, they *are* legal to own, and would be a common backup weapon for a law enforcement agent. Carrying one without proper permits is grounds for immediate arrest on the assumption you had the intent to bring a lethal weapon into a prohibited area.

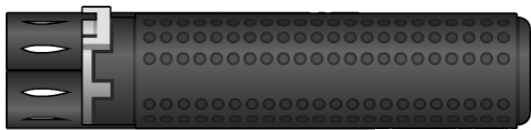

Normally holdout pistols are made of high-tensile strength fibers woven over a thin metal barrel, but they can be made in various illegal ways to avoid most short-range sensor technologies. Since the weapon is about the size and shape of a fat penknife, it is readily concealable. This pistol is gripped like you would a closed penknife, aimed using a high-intensity laser dot and fired with a thumb press. A holdout pistol can be reloaded, but since the reloads are a unit of barrel and ammo, carrying reloads kind of negates the idea of having a very concealable weapon. It would be better to simply carry a spare holdout.

**!** In game terms, this uses the 'armor-piercing' characteristic and reduces incidental cover or armor of the same tech era by 1d.

**pocket shotgun:** A simple weapon, basically a single caseless shotgun round, a minimum barrel, grip and laser sight. The end of the barrel is flared and flattened slightly to give a wider horizontal dispersion of shot, and the laser sight is similarly fanned so that the broad line made by the laser is roughly the center of where the shot will hit. This weapon gets +1 Accuracy per 3 range levels for aimed fire, to a maximum Accuracy of 3 and a maximum effective range of 32 meters.

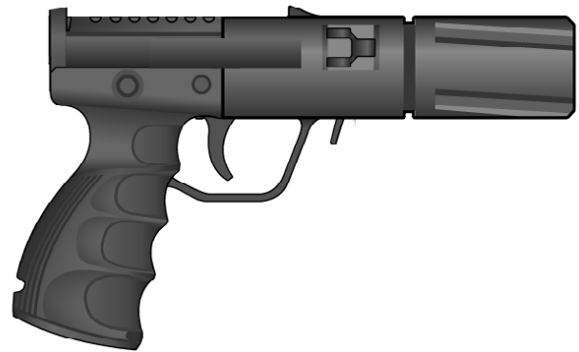

However, it cannot be aimed to make a called shot, just to accurately place the center of the shot pattern. At a range of +6 (3 meters) the shot will hit all targets in a hex, and the pattern will spread 1 hex to either side for each +3 range levels (2 hexes on either side at maximum effective range). Once shot has spread to fill a hex, each target can be hit a maximum of once. Pocket shotguns are not in the 'legal weapon' category because of their indiscriminate firing pattern. Permits are available, but require a demonstratable need for such a weapon and the permits are generally only applicable in that circumstance or while travelling to or from it. Travelling outside of Terran territory is usually sufficient justification, but of course you would also need permission to *import* such a weapon if going to a polygon that was the home of some other race. The pocket shotgun is a cheap and reliable weapon of choice for colonists that need to defend themselves against local carnivorous or otherwise hostile creatures. Light enough for anyone to carry, requires little skill to use and generally dissuades or incapacitates most wild animals, or at sufficient range, groups of them.



**datashare module:** Some other weapon accessories in the gear list are obvious in their purpose. This one requires a little explanation. It allows any weapon similarly equipped to pass its data on to any other weapon in its network. So, if you 'tag' a person in the digital sights of your weapon, that person's location relative to you is transmitted to everyone else and shows up on their sights as relative to them. So, if you can see someone against the side of a building, your friend on the other side of the building now knows and will not step around the corner into an ambush. In practical terms it just means that *adventurers* can see any combat map drawn by the gamemaster. Which is the way they act *anyway*, since the adventurers operate under the guidance of *players* who are seeing that map. Advanced use of a datashare module requires familiarity with Tactics skill and may allow situational bonuses to attacks.

**bubble tent:** A lightweight tent made with electroactive fabric ribs. You just push a button and it unfolds and 'inflates'. Built-in electroluminescent panels provide interior lighting, and it is big enough inside for two people and two packs, or four people who are very comfortable with each other. It has a manually attached rain fly and normal tent pegs to secure it to the ground. Suction pads are available for on-scarth use. A bubble tent is not suitable for high wind conditions without a set of accessory poles to provide extra stiffening and it is *not* suitable for arctic use.

**scarthrunner:** A specialized wheeled vehicle designed expressly for travel over uninhabited polygons. They are lightweight vehicles with deployable solar panels and internal semiconductor arrays designed to convert Aethos' weak, oscillating ground-level magnetic field into power. Together, these two sources are sufficient to push a scarthrunner at up to 160kph with unlimited duration. However, this is at the cost of no armor and negligible cargo capacity (driver, passenger and maybe one passenger's worth of space for gear).

There are heavier and roomier models for expedition purposes, but they can only manage sustained speeds of perhaps 60kph, or up to 120kph for short bursts using small exocap banks. They are still unarmored, but can carry several people or a ton of cargo.

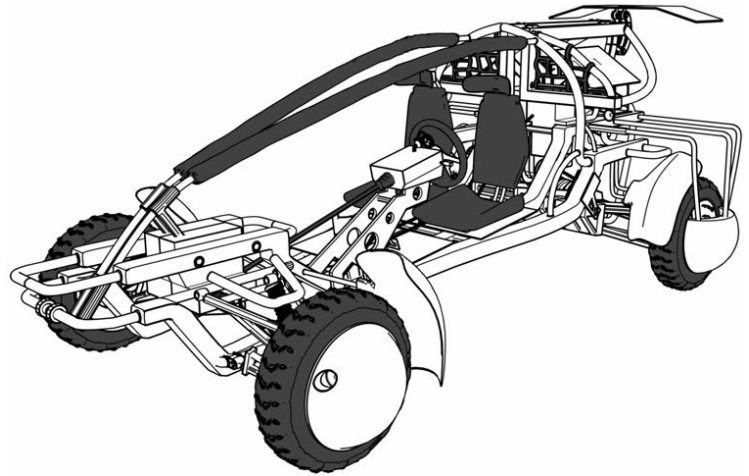

Both types of scarthrunner are bought or leased by groups seeking to found new colonies. The fast ones scout ahead, the slow ones carry the colonists. Those that lease them also hire drivers from the same company, and the scarthrunners simply drive home after the colonists are dropped off.

! Even though there are plenty of them in the setting, you will not find many stats for heavy or extremely large vehicles. If you have the means of dealing with foes who are hiding behind 12d+0 of armor or more, then you have it. If you do not, then you have no business confronting that sort of threat. Similarly, it does not matter how much or how high-tech someone's body armor is if they get hit by an anti-tank rocket. Sometimes the adventurers simply need to make themselves scarce, or accept that surrender is better than going down fighting.

! As a design note, vehicles with both an energy bank and an engine would have two sets of energy, a larger one with mundane fuel and a smaller one with self-replenishment.



**Cartoo Small Claw pistol:** The Cartoo have a wide variety of small arms in common use, of which the Small Claw is just an example. The Small Claw usually requires a cybernetic interface, but can be operated using external prosthetics if the Cartoo in question is on a budget. Its gun-mounted camera allows the user to shoot around corners at only +2 to difficulty, and make aimed shots from the hip or around corners. In addition, the pistol is usually booby-trapped. Attempting to fire it without the right interface or implanted recognition chip sets off a small explosive charge in the grip, which usually cripples or amputates the hand holding the weapon.



For use by Cartoo internal security, odds are heavy that some of the grenade fragments are micro-encoded so they can be spotted with RFID scanners, allowing for the easier location and interrogation of victims and/or witnesses.

**thud pistol:** This is a Cartoo specialty weapon, often used by bodyguards but not permitted on the Terran side of the border in any trade dealings. It is a disposable, fat, auto-burst mini-grenade launcher. It almost always uses directed fragmentation shaped charges, doing 6d+1 lethal damage to whatever it hits, a 3d+1 normal explosion on the side towards the firer and a 3d+1 lethal explosion in the direction of fire and to the sides. On the Cartoo side of the border, innocent bystanders are expected to look out for themselves if one of these is drawn. In a bodyguard application, you simply aim it at the threat and fire three round bursts until the threat goes away. A bodyguard will at least have a heads-up display linked to a weapon camera, allowing it to fire around corners, and giving the user any capabilities of the weapon camera (low-light, thermal, etc.), while cybered-up bodyguards will have a direct neural patch for these feeds, as well as being able to lock or unlock the weapon for use.

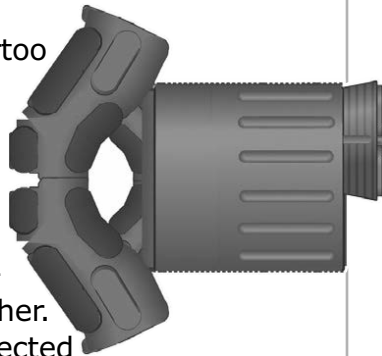

**SSD:** Initials for Standard Self-defense Device, an agreed-upon self-defense weapon for Cartoo on the Terran side of the border, with an equivalent configured for human anatomy for Terran use on the Cartoo side of the border. Terrans given the weapon feel the initials stand for Substandard Suicide Device and the Cartoo have their own, equally colorful moniker. An SSD is a semi-auto pistol with an integrated visible wavelength laser sight and gun camera that activates whenever the weapon is drawn. It holds 20 shots in a removable clip and the propellant is microtagged so that any use of the pistol has a better chance of being traced to a particular batch of ammunition (forensics can sweep the scene of a shooting for micro-tagged particles and compare them to a sales database).

SSDs have less power than a Terran 'legal weapon' and are really only useful against unarmored targets or in the hands of a very skilled shooter.

Against a foe who knows that is what you are armed with, their only real use is as a noise-maker to draw the attention of the police or other authorities.





**Red Fang:** This is the core of the standard

Cartoo assault rifle, used by regular troops. It is an unremarkable design, firing caseless ammo through a robust semi-auto or auto-burst receiver. It is equipped with a light-amplification sight that gives it an Accuracy 5 in the daytime and 3 at night. While it has no other advanced features, it is designed to have them added on by individual Cartoo military groups. Known variants include more accurate sniper versions (Accuracy 6) with a longer barrel (+1 damage), use of penetrating, stopping or armor-piercing ammunition, thermal sights instead of light amplification, laser designators, and under-barrel grenade launchers roughly the same as a thud pistol.

Versions of the weapon fired using a full cybernetic arm automatically compensate for recoil using the known characteristics of the weapon and the cybernetics, allowing for no loss of aim and no recoil penalties between shots.

**Scouring Wind MG:** This is a particularly nasty weapon used by low-value assault Cartoo assault troops. It is a rotary machinegun made of stamped metal parts and rough castings. Mounted on two-person all-terrain vehicles and loaded up with ammo, troops sent in first will be ordered to just 'shoot at everything'. Those who do well and survive get promoted up in their organization. Those who do not still cause a lot of havoc. A Scouring Wind lays down a volume of fire that cannot be dodged, and the only defense is keeping yourself behind *very* solid cover. It fires about thirty rounds per second, and even if a target can withstand this fire, the hail of bullets is usually sufficient to craze vision blocks and shred external sensors. In normal deployment, it is equipped with a 4d+1 gunshield (forward arc) and a videogame-like 'radar' that uses all available sensor data to show the position of friendly troops, hostiles and the last known position of hostiles no longer visible.

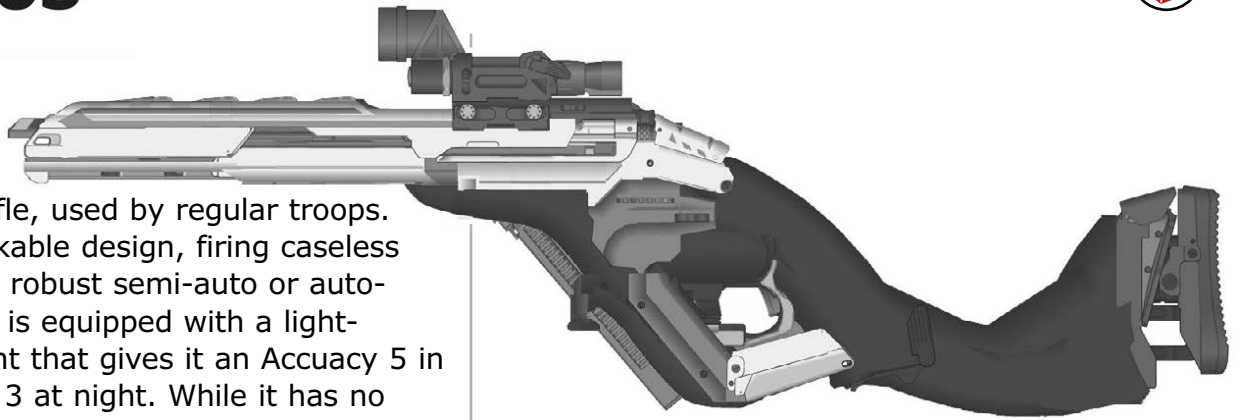

On a sophisticated vehicle this could be a very serious advantage, but in most deployments all it does is pinpoint the locations enemy fire is coming from.

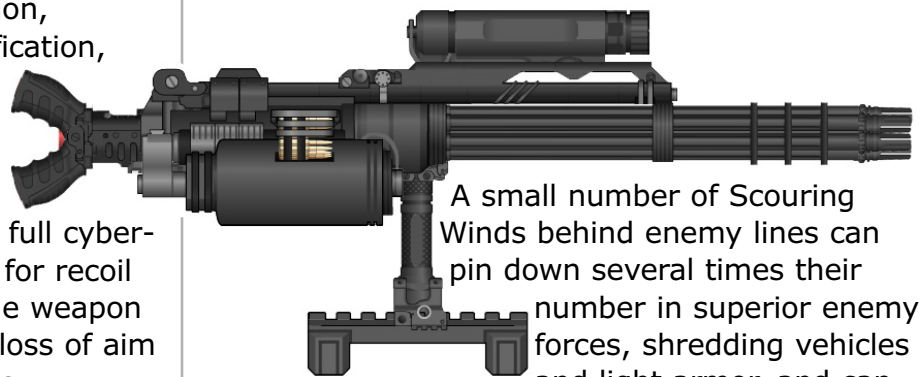

A small number of Scouring Winds behind enemy lines can pin down several times their number in superior enemy forces, shredding vehicles and light armor, and can do a lot of damage before being taken out. A Scouring Wind makes a unique sound, approximately like a tin roof being fed through a jet engine.

**Drinn MLRS:** This is a standard Drinn portable heavy weapon, composed of a seven-tube 38mm launcher and a removable optical sight (with anti-laser coatings). Each tube holds a single extremely high-velocity rocket with a proximity-fuzed dual purpose warhead. This acts as a small armor-piercing shaped charge to the front and a fragmentation charge to the sides. It is designed to be used against unfortified structures, light armored vehicles, clusters of infantry and low-flying aircraft. It does not do an exceptional job at any of these roles, but it is adequate at all of them. The launcher is disposable, but the sight is reused.



**Night Kite:** This is a Drinn aircraft with some modifications for human use. Specifically, the controls have been replaced with those for humans, the instrumentation is adjusted for human units of measurement and so on. This particular design and configuration is popular with smugglers and anyone who wants to transport a moderate amount of cargo without being noticed. A Night Kite can carry up to sixteen people in cramped seating (plus a pilot and co-pilot), eight in fairly roomy seating, or some combination of seats and cargo with a total mass of less than two tons. Night Kites are conventionally fueled, which gives them a limited range (1000km radius), but they can carry extra tankage to extend this.

Night Kites are usually painted dead black and fly only at night with pilots relying on night vision goggles and passive direction-finding gear. Quiet and able to take off and land on fairly short dirt runways, they are the normal transport to and from illicit colonies, for cross-border smuggling and other low-profile uses.

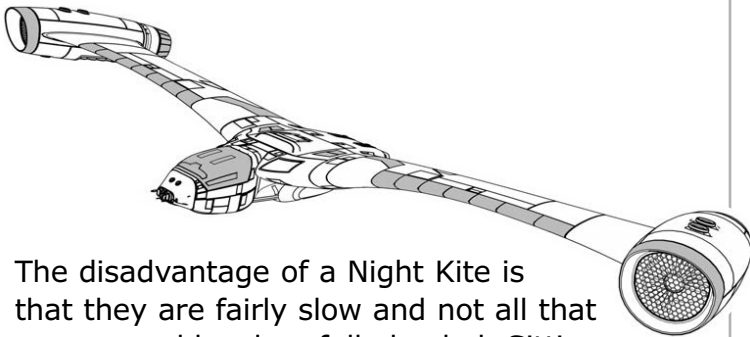

The disadvantage of a Night Kite is that they are fairly slow and not all that maneuverable when fully loaded. Sitting ducks for someone who can get a visual targeting lock, but almost impossible to target with radar or emission-seeking munitions. Night Kites rely on a complex analog auto-stabilizer to offset their lack of vertical control surfaces. Damage to this will make the Night Kite significantly harder to fly (special -1 penalty for each hit taken to the 'gadgets' hit location). This system usually requires a Drinn tech to repair it back to normal function.

**Gunk:** This is a defense technology used by the Ancients, and consists of a variety of airborne molecules with specific characteristics. In particular, one part of the molecule is designed to bind to the surface of a particular substance, and another molecule with very specific properties is attached to give the gunk its effect. For instance, the gunk might have affinity for synthetic sapphire and an added molecular chain that blocks a particular wavelength of light. Or, it might have an affinity for a particular synthetic lubricant and also act as an extreme thickening agent. The first application would cause the emitter of a laser weapon to dump its energy at the emitter surface, ruining the weapon. The second application would cause a conventional firearm using that lubricant to seize up.

The usefulness of gunk requires a bit of foresight on the part of the Ancient using it. But, knowledge is literally currency among the Ancients, so making educated guesses about the likely threat someone might bring into Ancient territory is not that difficult for them. Gunk *can* be detected by scanners set for a specific type (if you know it in advance), or noticed in routine maintenance of a gunked device, but it is not generally visible or smellable. Gunk generally has a half-life of a few days, after which it disassociates into harmless gases and inert powders.

Gunk is mainly a defensive technology, used by an Ancient who does not fully trust their guests. It can only be effectively used indoors, where the necessary concentrations can be achieved to make it effective. An Ancient might pay to have it deployed in an autocab, or have it permeate the air at their place of business or residence. It is said that the Ancients have an ingestible gunk that can interfere with certain neural pathways used in cybernetics, but this is not confirmed. Gunk is, of course, readily adaptable as a species-specific poison or incapacitating agent, and with sufficient information could be tailored to only affect a specific individual.



**Cartoo Assault ATV:** This is a wheeled lightly armored, two-person vehicle used for a variety of roles by the Cartoo. In an assault role it is fitted with armored seats and a Scouring Wind MG in a rear pintle mount. The ATV runs on a simple exocap system with one electric motor for each pair of wheels. The suspension can be raised or lowered for optimum on- and off-road use, and the front is sometimes equipped with a brush-cutter and reinforced ramming plate. It has no special sensors or other add-ons. It is not amphibious but all its systems are waterproof and damaged electrical components can be manually isolated if necessary. The design is actually a Cartoo export and is popular in rural areas. This actually serves a purpose, since it means you cannot just assume one is hostile if conflict breaks out. The common-sense notion is that if conflict breaks out and you own one, keep it garaged.

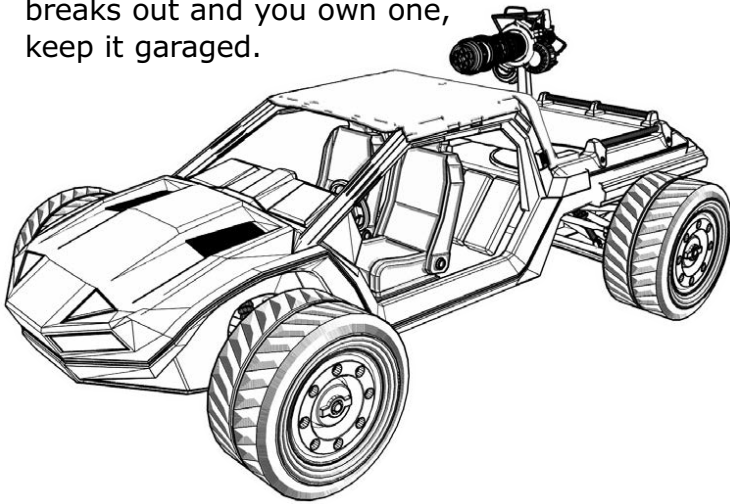

**Y872A3 APC:** Or, the Armored Personnel Carrier, model year 872, A series, revision 3. This is the prior generation of Terran armored personnel carriers, which after being stripped of heavy weapons and advanced electronics, were put on the civilian market to help defray the cost of the Y910A1. Since we are currently in year 935, existing Y872's are somewhere between 30 and 60 years old. However, the chassis, power plants and running gear have plenty of life left in them and parts are readily available on the secondary market. The most common spare part needed is run-flat tires, which cost about 2000 Eur each.

The Y872 is a diesel-electric. It can run quietly on exocap power alone and can slowly self-recharge, allowing it to stay stationary and still run climate control and electronics. Normally, it uses a multi-fuel diesel engine to drive a generator, which in turn powers an electric motor to drive the tracks. In this mode, the exocaps provide the additional power needed for acceleration or hill-climbing.

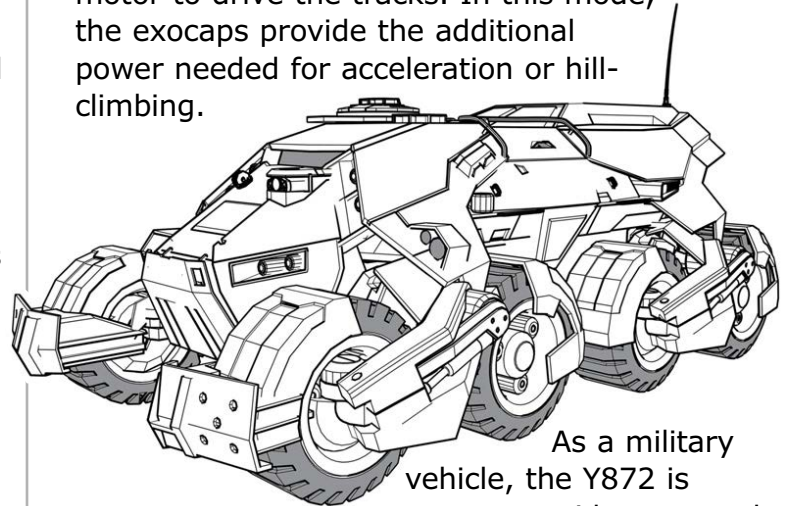

As a military vehicle, the Y872 is meant to provide crew and passengers with protection from small arms, machineguns and frag weapons, and to give limited survivability against heavier weapons. In particular, as many components as possible are mounted so as to absorb damage that penetrates the front armor. Reactive armor plates may be applied to the front to provide limited single-strike protection against shaped charges, and the external stowage points on the sides allow external gear to buffer hits that would strike the passenger compartment. The idea is that if the Y872 is struck by heavy weapons while advancing into combat, the vehicle itself will survive long enough to let the occupants exit out the rear. Since there have been no active wars fought involving the Y872, this has not been put to the test in real-world conditions.

The Y872 has a small turret that normally mounted a heavy machine gun and either a gauss cannon or a rocket launcher. On civilian models, the empty space is replaced with other gear, depending on the needs of the end user. It may be as simple as extra storage, an observation bubble, communications gear, or even weapons (since the turret ring is still in place).



All night vision, thermal imaging, computing, radar and communications gear has been stripped for the demilitarized models. Secondary markets can provide replacements or luxuries to fill these voids (refrigerators, microwaves, stereo systems, etc.). The Y872 is fully amphibious with little preparation, but unwieldy in water and may actually have negative bouyancy if fully loaded (i.e. it sinks). However, with the removal of the weaponry and ammunition, the civilian models seldom have this problem.

**expedition crawler:** This is one of a series of vehicles made by various manufacturers, but with similar characteristics. It is normally a four or six-wheeled vehicle, driven using the same skill set as for a military truck, with identical or nearly identical controls and control placement. It has armor sufficient to stop legal weapons and may have attachment points for upgrade plates. It is amphibious and has a power train that can adjust the power to the wheels in virtually any fashion. The main engine is an electric motor, the main power source is a large exocap bank, and it will have a small diesel generator and inductive recharge coils so that it can work independent of any fuel source for about an hour per day.

Most expedition crawlers will have fold-out bunks, a small kitchen, and a tiny bathroom with a shower. Most will have retractable awnings, some with integrated flexible solar panels. Some will have external showers, fold-out tent panels to increase the usable interior volume, or external storage lockers.

! At gamemaster option, all resource-intensive items like vehicles are actually +1 cost over the listed amount. This is a recycling deposit that is refunded when the vehicle is scrapped. Most used vehicle sales pass this difference in cost on to the next buyer, since it is the person who scraps it that gets it back, not the original buyer.

The degree of luxury and utility is entirely up to the buyer. The listed cost is for a very utilitarian model, and prices run to up to +4 cost over this, not counting the extreme cost of any scientific instrumentation that one might carry. Used crawlers can be had for up to -4 off their new cost level, but you get what you pay for.

Crawlers of most types can be rented for about 250 Eur per day or chartered for about 400 Eur per day. Rentals are only possible for 'civilized' areas. Wanting to take a crawler into uninhabited or unsettled regions requires a charter and/or a waiver that makes the user liable for any loss or damage. Imagine a car rental agreement, but for something costing several times as much, and what you would have to sign in order to have permission to drive it someplace people might shoot at it or try to steal it.

Expedition crawlers are street legal, but they are painfully slow compared to highway traffic and may not meet *minimum* speed limits on major roads.

### Last gear note

Aethos is a *big* place, and times are changing, changing more profoundly than at any time in the previous ten centuries. Plenty of new gear will be invented, cobbled together or imported from other races during a campaign. As long as it fits within the tech eras the surface races are capable of and it does not unbalance the gameworld, let the players play with the power system to generate new gear if they want to. After all, computer-aided manufacturing is a readily available process for many races, so custom, one-of-a-kind items are not *that* much more expensive than the regular kind.



### Travel matrix

Earth has a complex geography and varying travel infrastructure. If you like, you can use the following chart to determine the time and cost and means of getting between point A and point B, at least in terms of state capitals (use the map on [page 3.1](#)). The first number is hours by air travel, the second is rail travel, the third is by smartroad. A dash means you cannot do that trip in one leg, but have to change trains, or in the case of a smart road, occasional stops to top off a vehicle's energy, rest and eat.

The first two include boarding and departure times in addition to actual travel time (up to an one hour for flights, half an hour for trains). All travel times round to the nearest hour. Numbers in **red** are departures once per day, those in **blue** are twice per day, those in **green** are four times a day and those in black are at at least six times a day.

The frequencies are based on proximity and gameworld relationships. For instance, there is generally more traffic in and out of the capital at Philadelphia, and Roanoke is portrayed as a railhub, so it has more frequent trains.

**i** The Montréal-Vladivostok route is 134, so it means there are at least six commuter flights per day with a 1 hour trip time, four passenger trains per day with a 3 hour trip time and it takes 4 hours to drive there on the smartroad.

It is impossible to say which exact departure times are associated with a mode of transport at a given city. The easiest way would be to pick a random time closest to the *desired* departure time and roll 1d for each possible chunk of time of 6 hours (round up). All results of more than '3' mean the next departure is that much later, each result of less than '3' means it is that much earlier.

	Petrograd	Philadelphia	Jinan	Vladivostok	Johannesburg	Juarez	Mieres	Denver	Santiago	Kathmandu	Mexico City	Bergen	Tampere	Montréal	Ankara	Tokushima	Canberra	Phoenix	Roanoke
Petrograd	-	111	22-	25-	26-	28-	27-	28-	29-	27-	27-	133	122	22-	24-	25-	25-	25-	23-
Philadelphia	111	-	223	25-	26-	28-	27-	28-	39-	27-	28-	24-	122	122	22-	25-	25-	24-	23-
Jinan	22-	223	-	133	26-	27-	28-	29-	39-	27-	37-	26-	23-	111	12-	26-	26-	26-	24-
Vladivostok	25-	25-	133	-	134	25-	28-	2--	2--	29-	3--	28-	26-	134	144	26-	28-	28-	26-
Johannesburg	26-	26-	26-	134	-	122	25-	27-	2--	28-	3--	2--	27-	25-	133	25-	27-	27-	26-
Juarez	28-	28-	27-	25-	122	-	133	26-	29-	28-	3--	2--	27-	25-	133	25-	27-	27-	26-
Mieres	27-	27-	28-	28-	25-	133	-	133	26-	26-	29-	28-	26-	27-	25-	235	16-	26-	24-
Denver	28-	28-	29-	2--	27-	26-	133	-	144	15-	28-	28-	26-	28-	26-	144	133	25-	25-
Santiago	29-	39-	39-	2--	2--	29-	26-	144	-	156	29-	28-	27-	28-	28-	26-	144	26-	26-
Kathmandu	27-	27-	27-	29-	28-	28-	26-	15-	156	-	245	25-	24-	27-	27-	24-	122	122	24-
Mexico City	27-	28-	37-	3--	3--	3--	29-	28-	29-	245	-	256	26-	28-	28-	27-	26-	244	26-
Bergen	133	24-	26-	28-	2--	29-	28-	28-	28-	25-	256	-	134	26-	27-	26-	25-	133	15-
Tampere	122	122	23-	26-	27-	26-	26-	26-	27-	24-	26-	134	-	123	14-	23-	23-	122	122
Montréal	22-	122	111	134	25-	25-	27-	28-	28-	27-	28-	26-	123	-	132	25-	25-	25-	133
Ankara	24-	22-	12-	144	133	233	25-	26-	28-	27-	28-	27-	14-	132	-	133	25-	25-	133
Tokushima	25-	25-	26-	26-	25-	135	235	144	26-	24-	27-	26-	23-	25-	133	-	133	24-	122
Canberra	25-	25-	26-	28-	27-	25-	16-	133	144	122	26-	25-	23-	25-	25-	133	-	133	122
Phoenix	25-	24-	26-	28-	27-	26-	26-	25-	26-	122	244	133	122	25-	25-	24-	133	-	122
Roanoke	23-	23-	24-	26-	26-	25-	24-	25-	26-	24-	26-	15-	122	133	133	122	122	122	-





**i** The Petrograd-Vladivostok route is 25-, so it means there are four flights (green number) and two trains (blue number) each day. Say you wanted to leave at 4pm. You roll 1d for the flights (four flights a day is about one each 6 hours). If the result was '2', , you are 1 point *less* than the target of '3'. This would mean the closest flight was 1 hour short of your desired time. So, on that day, the closest flights are at 3pm and 6 hours later at 9pm, with arrival at the destination two hours later (5pm and 11pm). Since there are two trains each day, that is about one each 12 hours so you would roll 2d. If the results were '4', '6', this is a total of 4 points *more* than the target of '3'. This would mean the closest train is at 7pm, and the closest *previous* one would be 12 hours earlier, at 7am, with arrivals five hours later, at either 12pm (3 hours ahead of when you wanted to leave) or 12am the next day (8 hours after your desired departure time).

Timing is occasionally important in adventures, like trying to catch transport to intercept or meet someone at a distant location, but Aethos is *not* about being a travel agent. The most important thing most of the time is the time and the cost.

Smartroads are always immediate access anytime, but only list times to the adjacent capitals to take into account food, recharging and sleep stops (just add up individual legs to get total travel time).

Travel costs are pretty straightforward, and are based on how you get there and how long it takes (figures are in cost levels).

<b>time in hours</b>	<b>1</b>	<b>2</b>	<b>3-4</b>	<b>5-8</b>	<b>9-16</b>
by air	-4	-2	+0	-	-
by train	-9	-7	-5	-3	-1
by smartroad	-12	-10	-8	-6	-4

	<b>cost</b>
class upgrade(air or train)	+2
local rather than express (train only)	-2
large vehicle(smartroad only)	+2
commuter route	-2

There are some special notes that apply to travel and the travel table:

- Fares are per person for air and train, and per vehicle for smartroads. A 'large vehicle' is anything big enough to carry more than about six people. Say that vehicles of 2 tons or less loaded mass can use the default cost.
- A class upgrade for air travel does not get you there any quicker, but includes more space, has more amenities and you save a little time on boarding and debarking. Trains will include fold-down bunks for trips of sufficient length.
- The default train is an express from one point to another. If your train stops at numerous places on the way, it is a 'local'. Add 1 hour to travel time per state passed through (minimum of +1 hour), but this extra time does not affect the cost.
- Routes with a time of 111, and maybe 122 (any color) have commuter routes. People will live in one area and use these forms of transport to get to work in another. For air and train these are 'one carry-on bag' and 'no lethal weapons without permit'. For speed, you have to give up the weapon check-in and check-out that would normally apply to legal weapons. If you want to carry a legal weapon, you can always use a smartroad. The difference between the air and train 'commuter' routes is that the air transport is often something like a passenger VTOL that will transport a group of high-income executives or others from a special parking lot in one area directly to a rooftop helipad in another city, while train commuting is like a subway, but with enough seating room for people to pull out laptops.
- Times listed are between capitals. Smaller cities or out of the way places take longer or require transfer delays.

The densest and fastest transport network on Earth is the one in the Petrograd-Philadelphia-Jinan-Montréal group of states. The Denver-Santiago-Kathmandu-Mexico City group is the slowest and most expensive.

The Bergen-Tampere route is also possible via high-speed ferry at the same trip time as a smartroad, except it can carry your car and the ferry has optional sleepover cabins.



The high-speed rail line operates between Petrograd, Philadelphia, Montréal, Jinan, and Ankara, though the Ankara end is at a terminal at the extreme south end of Montréal and passengers reach Ankara proper via cablecar, which adds an hour to the total time. So, all rail times that would involve high-speed rail but other destinations will have a one hour lag while you transfer to another train or you have to take a slower train for the entire trip.

Smartroad access to Tokushima from any route except Mieres and Denver are at +1 over the normal cost due to bridge surcharges. All smartorad and rail access to Santiago is at +1 cost because of tunnel surcharges.

Most destinations can be gotten to in multiple ways, but not all of them can always be used. For instance, the fastest land route to go from Vladivostok to Mieres is through Johannesburg and Juarez, but if there are any sort of military tensions, these routes may be closed and you have to take the longer route through Ankara and Tokushima. Similarly, the mandatory rail transfer station at the end of the high-speed rail from Montréal to Ankara means that anyone going further than Ankara will usually find it faster to take a slower train nonstop the whole way, even though it takes a hundred kilometer detour to find a stable route the train can climb. The Ankara-Montreal route is faster to drive than to take a train for. On the other hand, the Mieres-Tokushima route has a dedicated rail bridge across a narrow part of the Sea of Japan, while road traffic has to detour around and use roads down the main peninsula.

Practically speaking, airfares are either going to be 250 Eur or 500 Eur each way, since there are only a handful of 3 hour (1000 Eur) flights. The reasons you might not want or be able to take a plane can vary.

All commercial planes and trains on Earth value their capital investment. Trains require that you surrender any weapon you do not have a concealed permit for, to be returned with your luggage at when you debark. Airlines require that you surrender all lethal weapons, permit or not. It is *their* business, they do not *have* to carry you somewhere if you do not follow their rules. However making you surrender a self-defense weapon makes them somewhat liable under Terran law, so security is generally pretty good and they *do* have plainclothes security whose only job is to look like a normal passenger and carry a weapon.

There are also things like weight and comfort considerations. A normal airfare covers your person, a carry-on bag of no more than 10kg and one item of packed luggage of no more than 25kg. These limits are doubled for rail passengers, and each +1 bag of either type is +1 to the cost of the fare. So, you could have 100kg of packed luggage on a train for +1 cost, but this would be +3 cost on an airfare (you are adding nearly the weight of a paying passenger).

And of course, while smartroads are the slowest long-distance means of transport, you can enter or exit the road on any schedule you want and carry as many people and as much gear as your vehicle will hold for no change in the travel cost.

! If you read this section literally it would mean that there are only a few hundred airline flights a day for a nation of a few hundred million people. *Clearly, this is not the case.* The idea is to make a system that reflects the reality that you cannot always get the departure times or routes you want. For all the departures each day in the real world, you can still have trouble finding a way to get where you want on the day and time you want, and this section just gives the gamemaster a tool for it.



### Human weapons

name	uses	Acc	damage	shots held	weight	cost	P	armor	hits	notes
SSD	7mm bullet	1	2d+1	20 clip	.4(-15)	350(-3)	2	1d+2	2	legal weapon
Conventional pistol	6mm bullet	1	2d+2	30 clip	.8(-12)	700(-1)	2	1d+2	2	legal weapon
compact version	6mm bullet	0	2d+2	15 clip	.4(-15)	500(-2)	2	1d+2	2	legal weapon
Laser pistol	exocap	3	2d+2 <sup>S</sup>	15 clip	.8(-12)	1.4K(+1)	2	1d+2	1	legal weapon
compact version	exocap	3	2d+1 <sup>S</sup>	4 internal	.4(-15)	700(-1)	2	1d+2	1	legal weapon
Gauss pistol	3mm needle	2	3d+0 <sup>P</sup>	20 clip	.8(-12)	1.4K(+1)	2	1d+2	1	legal weapon
compact version	3mm needle	2	3d+0 <sup>P</sup>	10 clip	.4(-15)	1.0K(+0)	2	1d+2	1	legal weapon
Stun pistol	exocap	1	4d+1	20 internal	.5(-13)	700(-1)	2	1d+2	1	legal weapon
compact version	exocap	0	4d+1	6 internal	.3(-16)	500(-2)	2	1d+2	1	legal weapon
KK-511L	6mm bullet	3	2d+2	90 clip	2.0(-8)	700(-1)	2	2d+1	2	2h, legal weapon
Holdout pistol	5mm bullet	0	3d+0 <sup>P</sup>	6 internal	.2(-18)	700(-1)	2	1d+2	1	autoburst only
Holdout laser pistol	exocap	0	0d+2 <sup>S</sup>	2 internal	.5(-13)	350(-3)	2	1d+2	1	continuous beam
Pocket shotgun	18mm bullet	0	1d+2 <sup>S</sup> x3	1 internal	.3(-16)	350(-3)	2	1d+2	1	
Farming carbine	5.5mm bullet	2	4d+2	45 clip	2.5(-7)	1.4K(+1)	4	2d+1	2	2h, open sights
Farming laser carbine	exocap	4	4d+0 <sup>S</sup>	30 clip	2.0(-8)	4.0K(+4)	3	2d+0	2	2h, scope
Heavy hunting rifle	7.5mm bullet	4	5d+1	6 clip	3.0(-6)	2.8K(+3)	2	2d+2	2	2h, +1 Acc w/scope
Hunting laser rifle	exocap	7	5d+1 <sup>S</sup>	6 clip	3.0(-6)	5.6K(+5)	2	2d+2	2	2h, scope
Hunting shotgun	18mm bullet	2	4d+1 <sup>SG</sup>	6 clip	2.5(-7)	1.4K(+1)	1	2d+1	2	
GK-762 assault rifle	4mm needle	4	5d+1 <sup>P</sup>	65 clip	4.0(-5)	11K(+7)	4	2d+2	2	2h, autoburst, scope
GG-851 gren. lchr.	35mm grenade	2	-	3 clip	1.6(-9)	2.0K(+2)	3	2d+0	2	2h
frag grenade			4d+1		.3(-16)	45(-9)				lethal explosion
anti-tank grenade			9d+1 <sup>a</sup>		.3(-16)	350(-3)				3d+1 lethal expl.
riot control			5d+1		.3(-16)	45(-9)				non-lethal expl.
flechette round			2d+1 <sup>P</sup> x4		.3(-16)	30(-10)				
KK-511 assault rifle	7mm bullet	4	5d+0	45 clip	4.0(-5)	5.6K(+5)	4	2d+0	3	autoburst, scope
KG-510 gren. lchr	35mm grenade	2	-	1 internal	1.3(-10)	1.4K(+1)	2	2d+0	2	2h
frag grenade			4d+1		.3(-16)	45(-9)				lethal explosion

### Drinn weapons

name	uses	Acc	damage	shots held	weight	cost	P	armor	hits	notes
Drinn pistol	9mm bullet	2	4d+1 <sup>P</sup>	15 clip	3.0(-6)	1.4K(+1)	4	2d+0	3	semi-auto
Drinn battle rifle	11mm bullet	5	6d+1 <sup>a</sup>	25 clip	13(+0)	5.6K(+5)	6	3d+0	3	semi-auto
Drinn MLRS	38mm rocket	3	10d+1 <sup>a</sup>	7 clip	13(+0)	4.0K(+4)	6	3d+0	3	autofire only, plus 5d+2 lethal expl.

### Tuaqq weapons

name	uses	Acc	damage	shots held	weight	cost	P	armor	hits	notes
Tuaqq laser pistol		3	3d+0 <sup>S</sup>	23 clip	1.3(-10)	1.4K(+1)	2	2d+0	2	autoburst
Tuaqq laser rifle		6	5d+0 <sup>S</sup>	65 clip	5.0(-4)	16K(+8)	5	2d+1	3	autoburst, scope
Tuaqq light plasma gun		3	10d+1 <sup>b</sup>	11 clip	50(15)	175K(+15)	8	3d+1	6	mounted weapon

### Cartoo weapons

name	uses	Acc	damage	shots held	weight	cost	P	armor	hits	notes
Thud pistol	25mm grenade	1	5d+2 <sup>a</sup>	9 clip	1.3(-10)	700(-1)	4	2d+0	2	autoburst, plus 3d+1 lethal expl.
Small claw pistol	4mm bullet	1	3d+2 <sup>P</sup>	30 clip	1.3(-10)	2.8K(+3)	3	2d+0	2	autofire
Red Fang assault rifle	6.5mm bullet	5/3	5d+2	30 clip	4.0(-5)	5.6K(+5)	4	2d+0	3	autoburst, scope
Scouring Wind MG	15mm bullet	4	8d+1	2000 box	125(+10)	16K(+8)	8	3d+1	7	3x autofire only



### Melee weapons

name	damage	type	length	weight	cost	P	armor	hits	notes
Tool	strike-2	lethal	short	.2(-18)	45(-9)	1	1d+2	1	1h, several useful tools
Combat knife	strike+0 <sup>P</sup>	lethal	short	.3(-16)	45(-9)	2	1d+2	1	1h
Machete	strike+1	lethal	medium	.6(-13)	45(-9)	2	1d+2	2	1h
Spear	strike+2 <sup>P</sup>	lethal	very long	1.0(-11)	125(-6)	2	1d+2	2	1h, throwable
Sap glove	strike+1	non-lethal	short	.3(-16)	45(-9)	1	1d+2	1	hybrid armor knuckles
Stun wand or glove	3d+1	non-lethal	short	.2(-18)	90(-7)	1	1d+1	1	2 uses, self-charging

### Archaic ranged weapons

name	uses	Acc	damage	shots held	weight	cost	P	armor	hits	notes
Medium bow	arrow	1	2d+0 <sup>P</sup>	1 internal	.5(-13)	250(-4)	1	1d+1	2	2h, minimum Str 7
Heavy bow	arrow	1	2d+1 <sup>P</sup>	1 internal	.7(-12)	350(-3)	1	1d+1	2	2h, minimum Str 9
Medium crossbow	quarrel	3	3d+1 <sup>P</sup>	1 internal	2.5(-7)	700(-1)	2	2d+1	2	2h, scope, -1 init.

### Other weapons

name	damage	type	length	weight	cost	P	armor	hits	notes
Blastex	6d+1	half-lethal expl.	-	.5(-14)	175(-5)	1	1d+1	1	2x size/+1P is +1d effect
Grenade	5d+1	lethal expl.	-	.4(-15)	175(-5)	2	1d+2	2	thrown
Stun grenade	6d+1	non-lethal expl.	-	.4(-15)	175(-5)	1	1d+2	2	thrown

### Post-Atomic Era personal armor

name	armor	type	covers	weight	cost	P	notes
Normal clothing	0d+1	flexible	whole body	2.0(-8)	175(-5)	1	0d+2 footgear
Syntheleather	1d+0	flexible	whole body	2.0(-8)	500(-2)	1	1d+1 on footgear, worn as outer layer
Monoweave	1d+0	hybrid	whole body	2.0(-8)	1.0K(+0)	1	stiffens on impact, worn as underlayer

### clothing modifiers

Ruggedized	-	-	-	-	+2		50% chance of +1 armor(elbows, etc.)
Tailored	-	-	-	-	+2		+2 difficulty to spot concealed items or +2 on social tasks based on looks
Mid-level	-	-	-	-	+3		executive or middle-upper class
Formal	-	-	-	-	+6		wealthy or formal occasion
Light body armor	3d+2	flexible	torso(10-11)	1.0(-11)	350(-3)	1	concealable
	3d+0	rigid	arms(7-8)	.8(-12)	175(-5)	1	if concealed, does not cover joints
	3d+0	rigid	legs(13-16)	1.0(-11)	250(-4)	1	if concealed, does not cover joints
Ballistic jacket	3d+2	flexible	torso(7-12)	2.5(-7)	1.0K(+0)	2	tailored as normal jacket
Terran military(1)	5d+2	rigid	torso(9-12)	5.0(-4)	2.8K(+3)	1	not concealable
	5d+0	rigid	head(3-6)	1.3(-10)	1.0K(+0)	1	mil-spec add-ons are +4 cost
	5d+0	rigid	arms(7-8)	1.6(-9)	1.0K(+0)	1	not concealable, 1kg without gauntlets
	5d+0	rigid	legs(13-18)	2.5(-7)	1.4K(+1)	1	not concealable
Assisted armor(20)	6d+0	rigid	head+torso	40(+5)	64K(+12)	3	offsets its weight, +1 Strength
	5d+2	rigid	arms+legs				
Envirosuit(10)	3d+1	hybrid	whole body	10(-1)	2.8K(+3)	2	see text for details

### armor modifiers

Reflec add-on(concealable)	-	-	-	-	+1		+2 vs. first laser hit to a location
Ablat add-on(not concealable)	-	-	-	+1	+1		+6 vs. first plasma hit to a location
Thermablur add-on(not-concealable)	-	-	-	-	+1		prevents called shots by thermal scan
Microplate add-on(concealable)	-	-	-	-	+1		negate electrostatic/stun weapons



### Early Post-Atomic Era stuff

name	weight	cost	P	armor	hits	notes
Exocap, standard size	.1(-)	30(-10)	1	1d+0	1	holds 15 power, gets back 1 per hour
Wristcomp	.1(-)	250(-6)	1	1d+0	0	watch/appt. calendar/music/basic data connect
Flashlight	.1(-)	45(-9)	1	1d+1	0	exocap powered, unlimited use, 7m range
Heavy flashlight(1)	.3(-16)	125(-6)	1	1d+2	1	exocap powered, unlimited low use, 45m range
Datapad(1)	.8(-12)	1.0K(+0)	1	1d+1	1	nettop/full page reading/multimedia device
Holocam	.2(-18)	350(-3)	1	1d+0	1	
Holoprojector(1)	1.0(-11)	500(-2)	1	1d+1	1	
Two-way radio	.2(-18)	125(-6)	1	1d+1	1	unlimited low-power use
Translator	.3(-16)	250(-4)	1	1d+1	1	2d+0 skill roll, limited technical vocabulary
Duraphone	.1(-)	500(-2)	1	1d+0	1	25Cr per month access fee
Vidphone	.1(-)	1.0K(+0)	1	1d+0	1	50Cr per month access fee
Holovid phone	.1(-)	2.0K(+0)	1	1d+0	1	100Cr per month access fee
Digital binoculars(1)	.4(-15)	1.0K(+0)	1	1d+2	2	resolution circa 2000CE
Night vision goggle(1)	.4(-15)	2.0K(+2)	1	1d+2	2	
Thermal goggle(1)	.4(-15)	2.8K(+3)	1	1d+2	2	
Science field kit(1)	8(-2)	4.0K(+4)	1	1d+2	5	
Maker, 1kg capacity	10(-1)	1.0K(+0)	1	1d+2	3	for plastic, +1 cost for +2 mass, +4 cost for metal or ceramic, makes high-res object in 15 minutes
Tools of the trade	4.0(-5)	2.0K(+2)	1	1d+2	4	generic items for minimal use of a professional skill
RFID scanner(1)	.5(-14)	250(-4)	1	1d+1	2	
Bubble tent(2)	1.3(-10)	250(-4)	1	0d+2	3	takes no damage from punctures
Survival kit	.3(-16)	30(-10)	1	1d+1	2	firestarter, saw, water purifier, emergency blanket
Camping/travel kit	.8(-12)	65(-8)	1	1d+1	2	camp/travel eating utensils, hygiene supplies, etc.
Camping food	.3(-16)	15(-12)	1	1d+0	2	dehydrated, sufficient for 1 day for 1 person
Field medkit(1)	2.5(-7)	250(-4)	1	1d+1	3	
Plastiskin kit	.5(-14)	250(-4)	1	1d+0	2	
Diagnostic scanner	1.0(-11)	1.0K(+0)	1	1d+1	2	
Sensor bed	25(+3)	5.6K(+5)	1	1d+2	6	fragile
Biostasis tube	100(+7)	16K(+8)	1	1d+2	8	fragile, has power and supplies good for 1 week
Regen tank	1K(+19)	90K(+13)	2	2d+0	12	fragile, requires medical skills to use

### Weapon accessories

name	weight	cost	P	armor	hits	notes
Gun camera	.1kg	90(-7)	-	1d+1	1	records weapon use, inherent on most legal wpns
Heads-up glasses	.1kg	700(-1)	1	1d+0	1	integrates with gun camera for off-axis aiming
Thermal sight	.2kg	2.0K(+2)	1	1d+1	1	aim in total darkness using heat signatures
Night vision sight	.1kg	1.4K(+1)	1	1d+1	1	aim in low light or normal night conditions
Datashare module	.1kg	1.0K(+0)	1	1d+1	1	communicate with nearby friendly weapons



### Early Post-Atomic Era vehicles

name	mass	to hit	spd/hand	armor(f)	armor(s)	hits/DL	cost	notes
Personal ATV	.3 ton	-1	+14/+1	3d+2*	3d+2*	8/10	5.6K(+7)	-1 speed w/passenger
Scooter	.2 ton	+0	+13/+0	3d+2*	3d+2*	7/9	4.0K(+4)	-2 speed w/passenger
Motorcycle	.3 ton	-1	+15/+3	3d+2*	3d+2*	8/10	8.0K(+8)	-1 speed w/passenger
Autocab	.7 ton	-2	+13/+4	3d+2*	3d+2*	9/11	11K(+9)	seats 4, 2 hex cargo, no manual controls
Minivan	1.5 ton	-3	+14/+4	3d+2*	3d+2*	10/12	45K(+11)	seats 7, 4 hex cargo
Light off-road truck	2 ton	-3	+14/+4	3d+2*	3d+2*	11/12	45K(+11)	seats 3, 1 ton cargo
Military truck	4 ton	-4	+13/+6	4d+2	4d+2	12/13	90K(+13)	seats 3, 3 ton cargo
Expedition crawler	6 ton	-5	+12/+4	5d+1	5d+1	12/14	.5M(+18)	bunks 6, see text
Scarthrower I	.5 ton	-2	+14/+4	2d+2*	2d+2*	9/11	65K(+12)	seats 2, see text
Scarthrower II	2 ton	-3	+10/+6	3d+2*	3d+2*	11/12	65K(+12)	seats 6, see text
Y872A3 APC	16 ton	-5	+13/+4	7d+2	6d+2	14/14	1M(+20)	see text
Night Kite	4 ton	-6	+17/+6	4d+0*	4d+0*	12/14	4M(+24)	see text
Cartoo Assault ATV	1 ton	-2	+14/+3	5d+0	4d+0	10/11	65K(+12)	see text

\*note that civilian vehicle armor is -2d vs. weapons

### Terran travel costs

name	rental	notes
All-terrain veh.	-10 for 1 day	good off-road capability, one person plus gear, self-recharges in 15 hours
Compact car	-8 for 1 day	4 persons plus some luggage, self-recharges in 15 hours
Sports car	-6 for 1 day	2 persons plus some luggage, self-recharges in 15 hours
Average SUV	-6 for 1 day	light off-road capability, 5 persons plus luggage, self-recharges in 15 hours
Autocab fare	-8 for 1 hour	up to four persons plus luggage
Airfare	-4 for 1 hour	one carry-on at 10kg, one checked bag at 25kg
Train fare	-9 for 1 hour	one carry-on at 20kg, two checked bags at 25kg (+1 cost for overweight luggage)
Smartroad fee	-12 for 1 hour	for small vehicles. Commercial vehicles are +2 cost and up.
Suborbit fare	+5	to/from Ancient territory, luggage allowance two bags at 25kg each
Ocean fare	-7 for 1 day	to any nation adjoining Terran shores
Hotel	-7 for 1 day	use real estate and travel modifiers on cost

#### modifiers:

each 2x time	+2 cost	round extra time up
upper class fare	+2 cost	minimal room for tasks and work, meals and sleep space if trip is long enough
lower class fare	-2 cost	cramped, no sleeping facilities, anything except net access costs extra
on short notice	+2 cost	unless the fare is for permanently scheduled services like subways
high-risk	+2 cost	plus credit hold for value of any rental vehicle in case it is lost, stolen or destroyed because of improper conduct (insurance covers accident damage)

### Real estate

name	cost/week	notes
Storage unit	-11	or +0 per year. size is 2m x 2m x 3m, x2 size for +2 cost
Rental apartment	-7	lower class, no ownership, includes all utilities, approximately 50m <sup>2</sup>
Condo fees	-7	lower class

#### modifiers

name	cost/week	notes
Highly urban	+1	smartroads, walking distance to useful places like shops and restaurants
Urban	+0	some smartroads, good mass transit
Suburban	-1	nearby smartroads, acceptable mass transit
Rural	-2	outside smartroad grids except by coincidence, reduced net access
Quality	±varies	proportional to lifestyle (Philidelphia and Petrograd are an additional +1)

Name  Gender  Age   
 Background   
 Goals

Stam	Hits
1	1
2	2
3	3
4	4
5	5
6	6
7	7
8	8
9	9
10	10
11	11
12	12
13	13
14	14
15	15
16	16
17	17
18	18
19	19
20	20
21	21
22	22
23	23
24	24
25	25
26	26

**Strength** level  roll  d+

carry  strike  throw

strike d+  kick d+  throw d+

**Agility** level  roll  d+

fight  balance  throw  dodge

fight d+  balance d+  throw d+

**Awareness** level  roll  d+

cognitive  sight  hearing

think d+  spot d+  listen d+

**Will** level  roll  d+

toughness  charm  resistance

tough  charm d+  resist d+

**Health** level  roll  d+

speed  stamina  recovery

walk  run  sprint  recov

**Fate** level  roll  d+

shield  power  luck

shield d+  power d+  luck d+

1 3 5 7 9  
11 13 15 17 19

Skills	Attribute	bonus	skill roll
<input type="text"/>	<input type="text"/>	+	d+
<input type="text"/>	<input type="text"/>	+	d+
<input type="text"/>	<input type="text"/>	+	d+
<input type="text"/>	<input type="text"/>	+	d+
<input type="text"/>	<input type="text"/>	+	d+
<input type="text"/>	<input type="text"/>	+	d+
<input type="text"/>	<input type="text"/>	+	d+
<input type="text"/>	<input type="text"/>	+	d+
<input type="text"/>	<input type="text"/>	+	d+
<input type="text"/>	<input type="text"/>	+	d+
<input type="text"/>	<input type="text"/>	+	d+

head  d+  torso  d+  arm  d+  leg  d+

3-6 9-12 7-8 13-18

Gear	weight
<input type="text"/>	<input type="text"/>
<input type="text"/>	<input type="text"/>
<input type="text"/>	<input type="text"/>
<input type="text"/>	<input type="text"/>
<input type="text"/>	<input type="text"/>

Lifestyle  Invested

Savings

Traits	value
<input type="text"/>	<input type="text"/>
<input type="text"/>	<input type="text"/>
<input type="text"/>	<input type="text"/>
<input type="text"/>	<input type="text"/>
<input type="text"/>	<input type="text"/>
<input type="text"/>	<input type="text"/>
<input type="text"/>	<input type="text"/>
<input type="text"/>	<input type="text"/>
<input type="text"/>	<input type="text"/>
<input type="text"/>	<input type="text"/>
<input type="text"/>	<input type="text"/>

Enc	Str
-1	8
-2	6
-3	4
-6	2
-9	0
-9	0
any	0
A	0
S	0
P	0

level	roll	mass	dist.	time	qty
-12	-	.8kg	-	-	-
-11	-	1kg	-	-	-
-10	-	1.3kg	-	-	-
-9	-	1.6kg	-	-	-
-8	-	2kg	-	-	-
-7	-	2.5kg	-	-	-
-6	-	3kg	-	-	-
-5	-	4kg	-	-	-
-4	-	5kg	-	-	-
-3	-	6kg	.1m	-	-
-2	-	8kg	-	.5s	x.5
-1	-	10kg	.3m	.7s	x.7
+0	0d+0	13kg	-	1s	x1
+1	0d+1	16kg	.5m	1.4s	x1
+2	0d+2	20kg	.7m	2s	x2
+3	1d+0	25kg	1m	3s	x3
+4	1d+1	32kg	1.4m	4s	x4
+5	1d+2	40kg	2m	6s	x6
+6	2d+0	50kg	3m	8s	x8
+7	2d+1	65kg	4m	11s	x11
+8	2d+2	80kg	6m	15s	x15
+9	3d+0	100kg	8m	23s	x23
+10	3d+1	125kg	11m	30s	x30
+11	3d+2	160kg	16m	45s	x45
+12	4d+0	200kg	23m	1m	x60
+13	4d+1	250kg	32m	1.4m	x90
+14	4d+2	320kg	45m	2m	x125
+15	5d+0	400kg	65m	3m	x175
+16	5d+1	500kg	90m	4m	x250
+17	5d+2	640kg	125m	6m	x350
+18	6d+0	800kg	175m	8m	x500
+19	6d+1	1t	250m	11m	x700
+20	6d+2	1.3t	350m	15m	x1k
+21	7d+0	1.6t	500m	23m	x1.4k
+22	7d+1	2t	700m	30m	x2k
+23	7d+2	2.5t	1km	45m	x2.8k
+24	8d+0	3.2t	1.4km	1h	x4k
+25	8d+1	4t	2km	1.4h	x5.6k
+26	8d+2	5.1t	2.8km	2h	x8k
+27	9d+0	6.4t	4km	3h	x11k
+28	9d+1	8t	5.6km	4h	x16k
+29	9d+2	10.2t	8km	6h	x25k
+30	10d+0	12.5t	11km	8h	x32k
+31	10d+1	16t	16km	11h	x45k
+32	10d+2	20t	23km	16h	x64k
+33	11d+0	25t	32km	1d	x90k
+34	11d+1	32t	45km	1.5d	x125k
+35	11d+2	40t	64km	2d	x175k
+36	12d+0	50t	90km	3d	x250k
+37	12d+1	64t	125km	4d	x350k
+38	12d+2	80t	175km	6d	x500k
+39	13d+0	100t	250km	8d	x700k
+40	13d+1	125t	350km	11d	x1m
+41	13d+2	160t	500km	16d	x1.4m
+42	14d+0	200t	700km	23d	x2m
+43	14d+1	250t	1k km	32d	x3m
+44	14d+2	320t	1.4k km	45d	x4m
+45	15d+0	400t	2k km	2m	x6m
+46	15d+1	500t	2.8k km	3m	x8m
+47	15d+2	640t	4k km	4m	x11m
+48	16d+0	800t	5.6k km	6m	x16m
+49	16d+1	1kt	8k km	8m	x23m
+50	16d+2	1.2kt	11k km	1y	x32m
+1	+1	x1.3	x1.4	x1.4	x1.4
+2	+2	x1.6	x2	x2	x2
+3	+1d	x2	x2.8	x2.8	x2.8

**customs**

---



---



---



---

**permits**

---



---



---



---

**probations**

---



---



---



---

**custom combat forms**

---



---



---



---

**experience**

---



---



---



---

**starting points**  A  S  P

**traits**

**attributes**

**skills**

**powers**

armor	type	covers	weight	cost	hand	worn	pack

weapons	damage	Acc	shots	weight	cost	hand	worn	pack

gear	armor	hits	weight	cost	hand	worn	pack

**heaviest item**

**2nd heaviest item**

**weekly expenses**





July 4 2012CE

Blacksburg Tactical Research Center has made **EABA** supplements by third parties possible under the terms of the **EABA Open Supplement License**.

### **EABA Open Supplement License, Version 2.0**

The following License governs the copying, modifying and distributing of **EABA**-compatible material. By copying, modifying, and/or distributing such material, you are agreeing to be bound by the terms of this License. The content of this license may not be modified, but format, size and placement may be adjusted to suit the nature of a particular **EABA**-compatible work.

#### **1. Application**

This License applies to supplement material compatible with **EABA** produced by any individual or entity other than **BTRC**. It does not extend to any other products or works by **BTRC**. **EABA** itself is a copyrighted work and may not be copied, modified, translated or distributed without permission from **BTRC**. This license does allow specific, limited sections of **EABA** to be used in **EABA**-compatible supplement material, as delineated in section 3.2.

#### **2. Definitions in this License**

'Copyright Notice' means any copyright notice applying to **EABA**, **EABA**-compatible or derivative works.

'**EABA**-compatible' means a work which is not **EABA** but which refers to, is compatible with, and/or depends upon **EABA** in order to be fully utilized.

'Distribute' means to distribute by any media and in any form, whether gratis, for a direct or indirect fee, or any form of exchange. '**EABA**' means the copyrighted **EABA** roleplaying system, as expressed in the downloaded, printed, electronic storage media or any other versions of the product.

'The **EABA** Open Supplement License notice' means the following: 'This work contains material copied from or derived from **EABA**, the roleplaying system created by BTRC. You may not copy, modify, and/or distribute this material except in compliance with the **EABA** Open Supplement License. To learn more, visit the BTRC web site at <http://www.btrc.net/>.'

'You' or 'Your' means an individual or a legal entity exercising rights under this License.

### **3. Consideration**

In consideration for agreeing to use this License, effective on the date You accept this License, **BTRC** grants you a world-wide, royalty-free, non-exclusive License to the permitted uses described below.

**3.1** You may Distribute Your **EABA**-compatible or derivative material, provided that You must in every instance retain and prominently reproduce in all copies the **EABA** Open Supplement License notice, the Copyright Notice, and this license.

**3.2.1** You may include terminology specific to **EABA**, page format, blank reference sheets or diagrams from **EABA** and add to or expand upon **EABA** rules or rule concepts, so long as these do not exactly or conceptually reproduce existing **EABA** rules.

**3.2.2** You may create software to make **EABA**-specific dice rolls, utilize the **EABA** Universal Modifier Chart, or list equipment from **EABA**. You may not create software that uses the rules for adventurer creation.

**3.3** You may copy and Distribute Your **EABA**-compatible work, provided that You must in each instance send a copy of the **EABA**-compatible work to **BTRC** (if hardcopy or data storage medium) or [btrc@btrc.net](mailto:btrc@btrc.net) (if electronically transmitted) so that it can be archived publicly if a freely available work, or kept for private archival purposes if not.

### **4. Representation**

By Distributing Your **EABA**-compatible work, You represent that it is Your original creation and/or that You have sufficient rights to Your **EABA**-compatible works to make the grants described in this License.

### **5. Versions of the License**

**BTRC** may publish revised and/or new versions of this License from time to time. Each version will be given a distinguishing version number. New **EABA**-compatible works must always use the most recent version of the License from the **BTRC** web site. Once an **EABA**-compatible work has been published under a particular version of this License, You may continue to use it under the terms of that version or You may choose to use it under the terms of any subsequent version of this License published by **BTRC**. No one other than **BTRC** has the right to modify the terms of this License.



## 6. No warranty

You expressly acknowledge and agree use of **EABA** is at Your sole and entire risk. **EABA** is provided 'as is' and without warranty of any kind. **BTRC** expressly disclaims all warranties and/or conditions, express or implied, including but not limited to, implied warranties and/or condition of satisfactory quality, merchantability, fitness for a particular purpose and non-infringement of third party rights. No oral or written information or advice given by **BTRC** shall create a warranty.

## 7. Limitation of liability

Under no circumstances shall **BTRC** be liable for any incidental, special, indirect or consequential damages arising out of or relating to this License or Your use of **EABA**, whether under a theory of contract, warranty, tort (including negligence), products liability or otherwise. In no event shall **BTRC** total liability to You for all damages under this License exceed the amount of ten dollars (US\$10.00).

## 8. Trademarks

'**EABA**' is a trademark of **BTRC**. Subject to the terms and conditions of this License, **BTRC** hereby grants You, effective on the date You accept this License, a world-wide, royalty-free, non-exclusive License to use the trademark '**EABA**' for the sole purpose of Distributing **EABA**-compatible works. Acceptable graphic representations of the **EABA** logo are available upon request from **BTRC**.

This License does not grant You any rights to use the trademark or trade name '**BTRC**', '**Blacksburg Tactical Research Center**' or any other trademarks or trade names belonging to **BTRC** except as part of this License agreement.

## 9. Termination

This License and the rights granted herein will terminate automatically without notice from **BTRC** if You fail to comply with any term or terms of this License and fail to cure such breach within 30 days of being notified of such breach by **BTRC**.

**9.1** Where **BTRC** determines that a purportedly **EABA**-compatible work is in fact a violation of copyright, this constitutes a breach of this License. **BTRC** may terminate this License and the rights granted herein if You fail to cure such breach within 30 days of being notified of such breach by **BTRC**. **BTRC** may, at its option, use any applicable copyright law to protect its intellectual property rights.

**9.2** Where **BTRC** determines an **EABA**-compatible work does not comply with section 3 of this License, this constitutes a breach of this License. **BTRC** may terminate this License and the rights granted herein if You fail to cure such breach within 30 days of being notified of such breach by **BTRC**.

**9.3** Upon termination, You agree to immediately stop any further copying, modifying, and/or Distributing of the **EABA**-compatible work in question. Except in the case of copyright violation, You will not be liable to **BTRC** for compensation, indemnity or damages of any sort solely as a result of terminating this License in accordance with its terms, and termination of this License will be without prejudice to any other right or remedy of either party.

**9.4** Termination of Your License by **BTRC** shall not be effective to terminate the License of anyone else enjoying rights under this License.

## 10. Miscellaneous

**10.1** This License will not be construed as creating an agency, partnership, joint venture or any other form of legal association between You and **BTRC**, and You will not represent to the contrary, whether expressly, by implication, appearance or otherwise.

**10.2** Nothing in this License will impair the **BTRC** right to acquire, license, develop, market and/or Distribute products that perform the same or similar functions as, or compete with Your **EABA**-compatible work.

**10.3** Failure by **BTRC** to enforce any provision of this License will not be deemed a waiver of future enforcement of that or any other provision. Any law, regulation, or rule of interpretation which provides that the language of a contract shall be construed against the drafter will not apply to this License.

**10.4** If any provision of this License is held to be unenforceable, such provision shall be reformed only to the extent necessary to make it enforceable.

**10.5** This License constitutes the entire agreement between the parties with respect to the subject matter thereof.