

DATAFORTRESS 2.0.2.0

Presents:

ULTIMATE EQUIPMENT

Written by Deric Bernier (droc@mc2k.com)

UPDATED 4-30-13

The complete collection of all the Equipment created for the various articles and sourcebooks by Deric Bernier found on Datafortress 2020.



This is just one of many articles for the Cyberpunk 2020 Roleplaying Game you can find on Datafortress 2020, the largest, most Comprehensive Cyberpunk 2020 site in the world.

Visit it at:

<http://datafortress2020.oliwy.net>

FOOD AND DRINK



CHILL COLA 2eb

In the competitive soft drink market, Chill Cola Company reigns supreme. They owe their success to 1 special, and very secret ingredient, a chemical compound called "Delifreeze 64" (whose make-up is one of the most closely guarded secrets in the food industry). Delifreeze 64 is a product which is added to the drink before the container is sealed in a special vacuum sealed room. When the can is opened the Delifreeze 64 mixes with the air, and immediately freezes, creating a "slushy" inside the can, so no matter what the temperature of the can is (in normal situations), you can always enjoy an ice cold Chill. Their is another, even closer guarded secret to the cola's success. Delifreeze 64, while being perfectly safe on its own, becomes a mild physically addictive substance when mixed with the other ingredients that go into Chill Cola. Chill comes in a variety of flavors, including Chill Cola, Cherry Cola Chill, Citrus Chill, Dr. Chill, Mountain Chill, Grape Chill, and Chill Root Beer, and owns several chains of fast food restaurants. The Cola is the same price as normal soft drinks, and comes in the same size containers. Chill has also purchased Miller beer, and has applied the same technology.



DEHYDRATED/PRESERVED FOODS 10eb

MRE's have come a long long way. Now virtually anything you can imagine is available as a cheap long lasting food supply. All the fast food chains have gotten in on the craze. Of course regular old MRE's are still widely available, but hey let's face it, who doesn't want pizza and burgers? Of course it al tastes like pre-chewed newspaper and saltpeter, but who are we to judge.



ECO-ECHO URBAN BEEHIVE 200eb

This completely safe and environmentally friendly beehive is mean for use in high rises and other large buildings. The device is attached on either side of a large window or wall. The panel that affixes to the exterior allows the bees to come and go as they please, while the hive itself stays warm and cozy on the inside, perfectly sealed and safe. The hive is encased in clear plastic shell, allowing owners to see the bees, and making for an excellent educational device for you children, as well as conversation starter for your friends and family. Best of all a simple pull down cord allows you to drain off the honey, giving you free, unprocessed, pure honey, in nearly limitless supply.



GYPSY WINE 45eb per liter (80eb per liter to statics) (From Nomad Market)

There are many stills operated by the nomad community, from poor quality (5eb 1 in ten chance of going blind) to fine grade hooch. Gypsy Wine is the best of the bunch. It's taste resembles a sweet Sake, but its effects are much stronger, and it produces a mild hallucinogenic effect. It resembles the effects of absinthe. It's ingredients are kept a closely guarded secret, though rumors are abundant as to what's in it. The most common rumored ingredient is anti-freeze.

LIFESTYLE AND ENTERTAINMENT

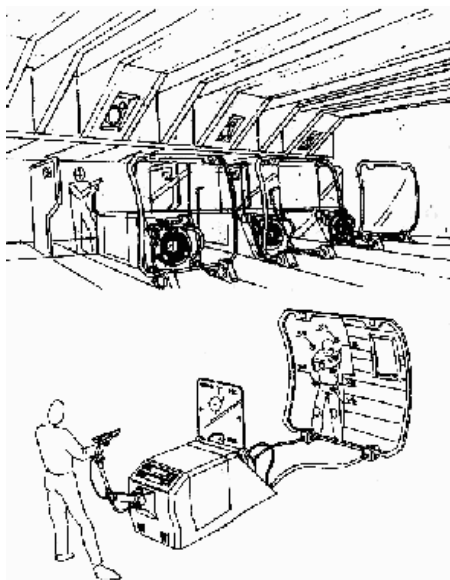

ARASAKA ELECTRONIC FIRING RANGE 675eb
Whether for improving your accuracy or just relieving stress, this electronic firing range is just the thing to keep your skills sharp.



BOJIM SAFE-BED 6500EB
Are you a paranoid nutcase or a conspiracy theorist who can't afford a safe room? Do you like sleeping in an oversized coffin? Boy, is this the bed for you. Once closed and locked, this hardwood over steel plate bed is virtually impregnable. Inside for a long stay, don't worry, it comes with built in video screens, a/v entertainment system, and hookups for your computer or cyberdeck. It also has its own ventilation system that shuts off in the event it detects airborne contaminants. Sleep easy, sleep safe.



CIGARETTE DISPENSER 200eb
These are simple cigarette touch screen vending machines. Select brand, then select from several options, such as tobacco blend (either American or Turkish, hash, cannabis, menthol, clove) and even flavorings (chocolate, strawberry, opium, cherry), each pack costs 6eb. By law the vending machine is also required to distribute anti-cancer nanite treatments.

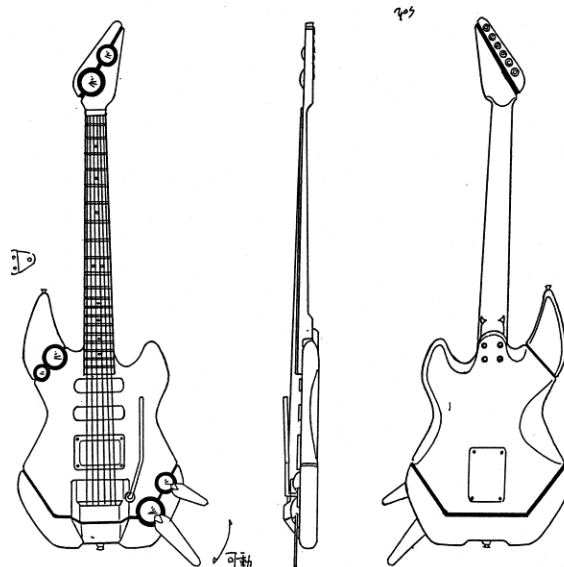

LES PAUL 2024 CYBERAXE 2545eb
Not only is this one of the finest guitars ever made, but it is so much more than that, contained within is a hard drive storage unit and mixing device, all controlled via smartlink. This allows for unlimited sound effects, back up music tracks, and so much more. With the Smartlink and the proper software and system, you can even control the lighting and stage effect. With enough skill, you can be a one band of unrivaled live performance.



MUSICAL INSTRUMENTS varies
(From Nomad Market)
Nomad Music is incredibly diverse, and like anything else in the Nomad Community hand made objects are prized well above anything manufactured or brought from a store. You can't always get that, but you would be absolutely amazed as what you can get. In addition to normal instruments, many nomad instrument craftsmen and artists have created new and unique instruments, with sounds all their own. These can range from anywhere between 25 eb for a simple handmade flute, to 3000eb for a totally unique instrument, electric or acoustic. For an additional fee nomad craftsmen can even build concealed weapons such as a sword or knife concealed within the neck of a stringed instrument (50eb plus cost of weapon).



NUBRELLA RAIN SHROUD 50eb
Keep your hands free and the rain and wind off.

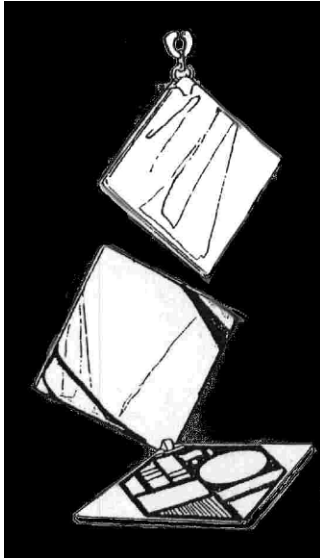

SANSUI MINIATURE HOLOGRAM PROJECTOR EARRING 250eb
Can store up to five minutes worth of recording. Inside the cover is a removable insert for defensive purposes (treat as a "Bloody Card").



SANYO PERSONAL THEATER MEDIA GLASSES 50eb
These special goggles allow you to pick up and play wireless television broadcasts. They also come with an input cable, allowing you to plug into any device that displays audio/visual data. The set comes with its own built in earphones and a small hand held remote for channel surfing, switching between media options, etc. It is a low cost, noninvasive alternative to a times square cyberoptic option, and much more entertaining.



SONY PS13 PORTABLE VR ENTERTAINMENT SYSTEM 250eb
Load any VR disk, jack in, and live the excitement. From the latest games, to sex sims, to virtual tours. All in the size of a ladies makeup compact.



SOLENT BUBBLE PODS 5,000-15,000eb
Eco friendly and easy to use, Solent Bubble Pods are the way to camp, or even live in comfort. Made of thick but flexible composite plastics, a Bubble Pod allows you to live in piece with nature, a solar powered generator pumps air into the pod, and the pod uses a special "airlock" entryway to enter and exit without losing internal integrity of the pod. For an additional 2000eb a stronger battery backed generator can be acquired which allows for the heating and cooling of the pod, making it ideal in harsh environments. The plastic that makes the pods comes crystal clear as standard, however you can buy tinted versions, and versions with opaque sections for greater privacy. The base on room plus airlock pod is 5000eb. Additional rooms can be added for 2000eb each, and a smaller bathroom with a removable chemical toilet and small shower combination over bare ground for 1000eb. The floors of the pods are plastic covered MDF with gel bottoms for stability and to create a level surface. Additionally, inflatable beds, chairs, and even a sofa can be purchased to accessorize the pods. Folding tables and battery powered lamps complete the structure, making it an elegant retreat, anywhere, anytime.

TOOLS



ADUMAX CRYOGENIC FREEZING FACILITIES

50eb per 6 inches square of material frozen
When an object is carefully cryogenically frozen, it becomes more dense. For example, if you cryogenically freeze an armor piercing round, it will be more effective, because it is more dense, therefore less likely to mushroom or break apart (AP ammo gains 50% penetration value). This applies to many things, including armor (soft armor gains .25 % SP although its EV raises by 50%, hard armor gains 50% sp and no EV change) and blades (become stronger, less chance of breaking), just to name a few.



HILTI PORTABLE ROTARY SAW 920eb

A diamond toothed rotary saw, which runs off its own power supply, or for prolonged use, plug adapter and comes with a 9 foot power cord. The machine itself has been specially designed for extremely quiet operation, however, noise will still be an issue depending on what you are cutting with it. The drill can cut 5 feet of inch thick steel in ten minutes, and the battery lasts 20 minutes before it must be recharged.



MILITECH "MR. FREEZE" 725eb

This odd looking device is a hand held liquid nitrogen sprayer. Extremely useful for getting past that lock you just can't pick. Or perhaps you would like to do a bit of sabotage. And for those of you twisted enough, it can even be used on your enemies. Simply spray the material with liquid nitrogen, wait a moment, and shatter it too pieces. The liquid nitrogen cylinder contains roughly 10 fluid ounces, and additional cylinders can be bought for 40eb apiece.



MINIATURE TORCH 125eb

Just what it says it is, A small cutting torch with a ten minute supply of fuel. It has enough fuel for about 1 minute of continuous use. Will cut through up to SP 25. It is recommended that safety goggles be worn when using this device



MITSUBISHI RXK-12 1250eb

Dual chain, titanium tips, and gas powered, this chainsaw will cut through steel like a knife through butter. The fuel tank holds enough to power the tool for one hour of continual use. Damage is 6d6AP.



NOMAD RIP SAW 250eb

(From Nomad Market)

This gas fueled high power saw rips through car bodies like nothing else, often carried as an emergency tool for cutting away vehicle body panels and the like in the case of an accident. Raffin Shiv carry them not only to cut into vehicles, but as weapons. (4D10AP damage).



PORTABLE GAS POWERED FUEL SYPHON 125eb

(From Nomad Market)

Retrieve fuel from disabled vehicles or old fuel tanks safely and quickly. Fuel container must be bought separately, or you can pump the recovered fuel directly into your own tanks.

SPORTING EQUIPMENT AND CAMPING GEAR

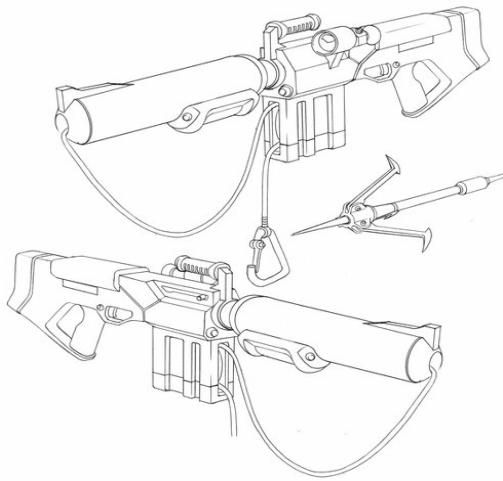

AMERACTIVE MARK III GRAPPLE GUN 520eb
 This grapple launcher sports an internal winch and 120 meters of wound monowire cable. As an added bonus you can switch heads on the grapple tip from either piton, grappling hook, or magnetic heads. The chosen hook is fired by use of an explosive cartridge, and the Mark III holds up to ten cartridges to save on reloading time.



ALITA MOVE SUIT 685eb
 This hard lightly armored suit has wheels on virtually every surface except the head. Static wheels on the feet, hands, elbows, and knees, free wheels on the back, chest, and abdomen. The suit allows for ridiculous agility and acrobatic feats, as well as unparalleled downhill speed. There are a few different models to choose from, though they only differ cosmetically. However, they do have a motorized version, only for the feet and forearm portions of the suit, but it allows for speeds of up to 40mp.

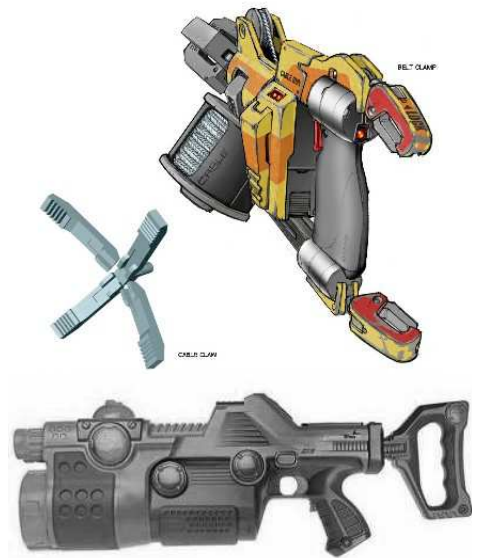

DYNALAR POWER ASSISTED GRAPPLING DEVICES 1950/3235eb

Both of these devices use explosive charges to fire their grappling hooks. The smaller device has a range of 60 meters and a 100 meter cable spool. Lifting a 300lb individual, the smaller gun retracts at a variable rate of up to 5 feet per second, and extends at rates varying from freefall to 1 foot per second. The larger gun has a range of 100 meters with a 150 meter cable spool and retracts up to 10 feet per second. With either device, for every 50lbs above 200 reduce the retraction speed by half to a maximum of 400 lbs, for weights under 200, double the retraction speed for every 100lbs. Both devices have built in clips for attaching to a belt or climbing harness, and both devices are shipped with 4 interchangeable grappling hooks (magnetic, collapsible standard which can be launched from either end, harpoon, and self driven piton). The explosive charges used are actually 10mm blanks (similar to the .22 cal blanks used in nail guns). The smaller version holds 8 shots in a revolver like cylinder, the larger version holds 20 shots in a top mounted magazine. Reloads can be bought from any major sporting goods store for 100eb per box of 25.



ENDURATECH HIGH ALTITUDE COLD WEATHER MASK 200eb

Developed for mountain climbers, this mask makes even the harshest winter conditions bearable. It's built in heaters pump a slightly heated oxygen mixture into the wearers face and under the mask keeping the users face warm, and the mask defrosted.



ENDURATECH SKI GOGGLES 2450eb

These ski goggles have a built in wide beam laser that scans in front of the skier to determine his speed and display it on an HUD in the visor. They also have Anti-Dazzle and Low Light optics tied to sensors that automatically adjust for the light around the skier. In addition there is a built in audio.video recorder with 4 hours recording time built in, so you can relive your extreme sport outings.

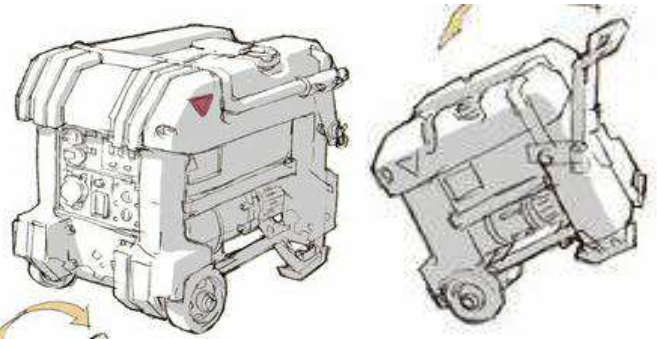

GE GENERATOR 750eb

This rather large portable generator will run for 12 hours on one 6 gallon tank of fuel, and provide enough power to run a home during that time.



FELI CLEATS 120eb

FELI makes a variety of cleats, for soccer, football, and more notably for climbing (shown). (+1 to athletics or climb check depending on the type bought. Cleats deal an extra 1d6 damage, but when worn on hard surfaces they provide a -2 to movement checks.)

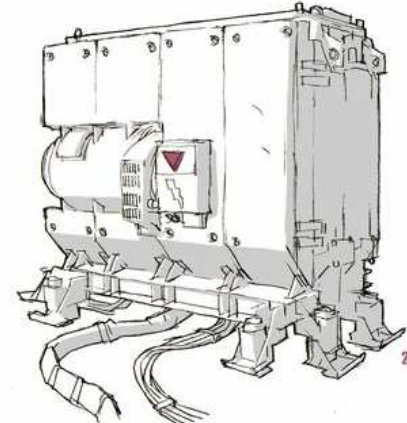

GE INDUSTRIAL GENERATOR 12000eb

This generator is non portable, but gives out enough power to run a civilian city block, a hospital, or most factories for a week before needing its 50 gallon fuel reserve refilled.



FLOWLABS FLOWBOARD 150eb

This innovatively designed skateboard has a curved row of small wheels spanning the width of the board at each end, due to this it handles almost exactly like a snow or surfboard, able to make impressively tight corners with grace.



GOTCHA-TECH LASER TRAINING SYSTEM 625eb

We all played laser tag as a kid right, well now you can do it again. The system begins with the two weapon add-ons, available for any standard handgun. The first of which is a specially designed cartridge which resembles a bullet, but sends a laser beam down through the barrel every time the trigger is pulled. An additional cartridge houses the battery and is connected by a small wire. For revolvers, the cartridges are longer to contain both the laser and battery. The vest contains laser sensitive panels which are state of the art and designed to only be sensitive to the lasers fired by the weapon add on.

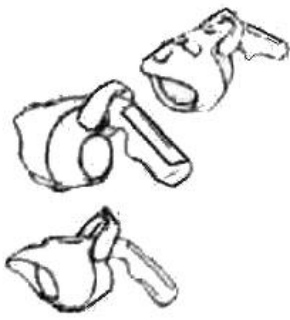

HARDIN HAND HELD SEARCHLIGHT 65eb

This is the most powerful flashlight on the market today, and can be fitted with an infrared filter for covert use. It is rechargeable from any standard light switch, and the bulb is guaranteed for life. Warning: do not shine directly in the face at point blank range, will cause eye damage, and possible permanent blindness.



H&K FLARE GUN 85eb

A pocket sized flare gun. 5 shots accepting a variety of rounds.

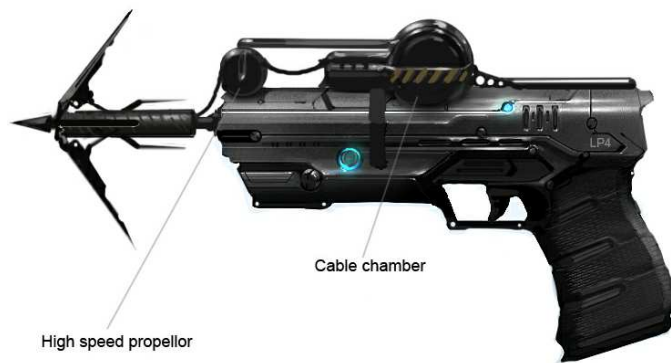

HK GRAPPLE PISTOL 250eb

This very small grapple gun has a 10 meter wound monowire line with a test weight of 180 pounds. The winch can only pull about 50 lbs, so it won't lift the firer making the device somewhat useless. The spool does have a locking mechanism rated to 200 pounds. Still punks and other lowlifes have taken to the device, as have climbers who treat it as an emergency line. Bounty hunters have also taken to carrying them, as a means of non-lethally grabbing runners. There are even reports of people using it to fish. It fires the grapple via 9mm blanks, and has a 10 round magazine.



HAWK SKATING HELMETS 40EB

The latest skating helmets from Hawk off full face protection and a much more stylish look. (SP:8)



HAWK HOVERBOARDS 4560eb

We have all seen these on ESPN, or maybe you have been lucky enough to see someone riding them yourselves. Well now you can own one as well. They use small thrusters, akin to miniature AV technology to stay aloft, and another thruster mounted to the rear for forward propulsion. The riders back foot is magnetically strapped to the board, leaving his front foot free for maneuverability. Be warned riding these boards is very dangerous, and some reach speeds of up to 60mph. Speed is controlled by foot placement and pressure, or for an addition price of 200eb you can get the board smartlinked(recommended). As stated, these are very dangerous, with a flight ceiling of about 80 meters and a 1 hour fuel supply, if you aren't an expert then you should stick to speeds below 20mph, and stick to an altitude no higher than 5 feet.



www.skateboard-decks.info



HAWK SKATEBOARDS 75-400eb
The best skateboards on the market.

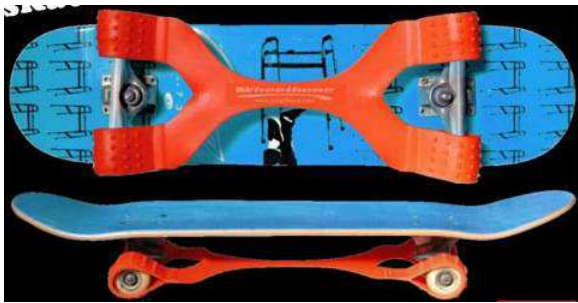

HAWK WHEELBONE 25eb
Originally created so skaters could train their olly's in the safety of their home without their wheels moving, it has also become popular as both a carry handle, and in some cases, has been used to make the skateboard a shield. (Most skateboards have sp: 8 and an SDP: 10.)



KAWASAKI "HAWKWIND" RACING HELMET 495eb
This racing helmet is the latest word in high tech comfort and safety. The exterior flip up facial protector is self tinting in your choice of black, blue, or chrome styles, and houses the receiver for the helmets built in short range radio (which can also connect to your cellphone). There is a second flip down visor which acts as a heads up display capable of accepting 4 cyberoptic options. Range boosting rabbit ear accessories (see further down) are also available.



KUNOCHI OMEGA SMART GLASSES 1250-1500eb
Available in a variety of styles and colors, these shades represent the ultimate in miniaturized technology. Looking like normal sunglasses, they allow 3 cyberoptic options to be installed, and 2 cybervideo options. If you want the pinnacle high tech cutting edge gear, and won't accept any sacrifice in style, these are for you.



KUNOCHI NIGHTHAWK GOGGLES 9800eb
Equipped with Low-Light, Thermograph, Ultra-violet, Image Enhancement, Anti-Dazzle, Times Square, Tele-optics, Audio Enhancement, Smartlink HUD, Echo-Location, 2 flashlights with alternate UV beams, Audio/vid recorder with 2 hours storage, waterproof to 40meters, and armored to SP:8, these are the ultimate in smart shade tech, an all in one device that has everything you could want.

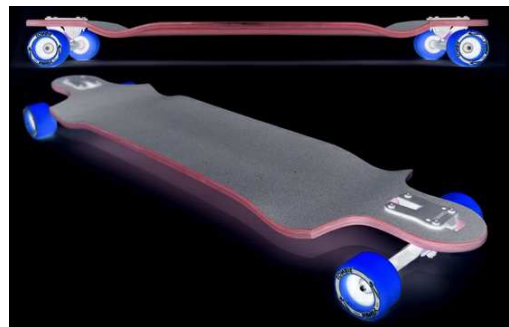

LANDYACHTS SPEEDBOARD 150EB
It's near impossible to really do any tricks at all with this board... but nothing beats it for speed.



META-CORP INFLATABLE HABITAT 60eb

Sometimes you just get tired of sleeping on the dirt, now you don't have too. This inflatable habitat is a tent and bed all in one. Who says nomad life has to be uncomfortable.



META-CORP PORTABLE WINDMILL 30eb

They can't power much (on a moderately windy day they can power a television set), but hey can be a life saver when fuel runs out and you need to power a radio. At the very least they are a good way to charge small batteries. For an additional 40eb the blades can be made from solar collectors, which allows them to double their electrical output on a sunny day (on a sunny moderately windy day they can power a microwave oven or a freezer.)

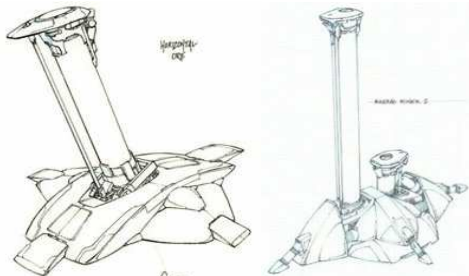

META-CORP PORTABLE WELL 245eb

These babies will drill down to 100 feet, then siphon the water back up through the hollow extending tube. A must have if you will be on your own for extended periods of time with no ready available source of fresh water. It also plugs in to any generator for extended use. Be very careful where you drill, as there is a very good chance the device will break if it hits a rock (2 in 10 chance every time you drill, with the numbers going up at the discretion of the GM).



MILITARY GEIGER COUNTER/AIRBORNE CONTAMINANT DETECTOR 125eb

Straight off the back of a military supply truck, these babies detect everything. An absolute necessity if your travels take you anywhere near places like Chicago, Los Alamos, or New York.

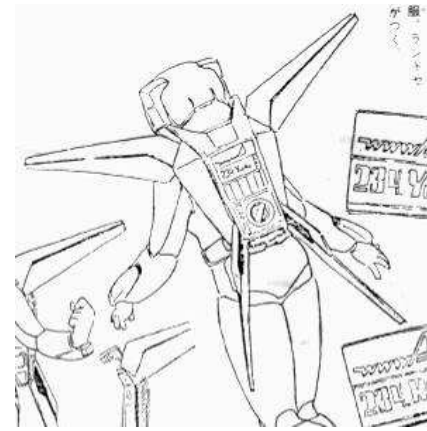

MILITECH LIFE JET 25,675eb

While not a true jet pack, the Militech Life Jet is a boon to pilots, airborne troops, and sky divers in that it replaces the parachute. When you bail out while wearing the Life Jet, the pack automatically measures altitude, and when you have fallen to the specified height of 300 meters to the ground then the 4 maneuver wings open from the pack and ignite the thrusters, slowing you down enough to maneuver to a safe landing. 2 small grip controllers are attached to pilots belt, allowing him to manually control and maneuver the pack, although the pack has only enough fuel for 5 minutes of flight. If after falling too 250 feet either the pack thrusters haven't ignited, or the speed hasn't dropped sufficiently, the pack will automatically release a small parachute. Or if the person desires he can manually trigger the chute release by pulling the ripcord protruding from the shoulder harness. The packs onboard computer knows which position it is in, and unless manually disengaged will right itself for the slowest possible descent. While the device does not replace ejector seats, or parachutes for beginners, it does allow a more streamlined freefall and is less cumbersome than a standard parachute. For the military, for whom it was designed, it also allows ejecting pilots and airdropped troops to present a smaller faster moving target for a longer period of time, making it harder for the enemy to hit them while they descend, unlike a parachute, which makes the person a large, easy and helpless target to enemy forces. Keep in mind that this is still in the testing phases, and Autumn Blade cannot be held liable for any accident, injury or death that might occur from using the Militech Life Jet.



MULDER FOLDING SKATEBOARD 250eb

This skateboard folds fore easier storage, When unfolded, a titanium plate on either side rotates to lock it in place.



NOMAD GIZMO 175eb
(From Nomad Market)

A jack of all trades, this device does it all. It is a water tester, able to detect any chemical, biological, or radiological contaminants in water (it won't be able to identify them for you, but it will tell you how safe the water is to drink). It is a personal PDA and GPS, and it is a portable digital media player. What more could you ask for..... oh yeah, the whole thing fits in your pocket too.



NOMAD SMARTGOGGLES 500eb

These riding goggles not keep the dirt and bugs out of a nomads eyes, but are made from cannibalized smartshades... usually only having one or two optic options, with static filled grainy resolution... but it just goes to show a nomad doesn't throw anything away.



NOMAD HIPSACK 10-200eb

These carry bags are designed for versatility, comfort, and convenience. They provide a series of compartments to hold maps, keys, and other day to day necessities within easy reach. Some are simple belts, but the better styles are designed so that they can be worn as a belt, a satchel, or even a back pack, depending on style and mood of the wearer. Price varies by style and material.



NOMAD KNIFE TOOL 20eb
(From Nomad Market)

This is a do it all utility blade with a near endless amount of uses. The deluxe model (30eb) comes with a steel telescoping handle allowing the tool to be used as a hatchet.

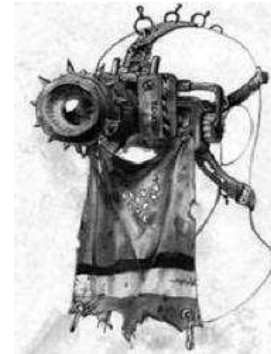

NOMAD NIGHT VISION 135eb
(From Nomad Market)

Since the first South American Conflict cheap early generation military surplus Night Vision optics have flooded the market. Usually they are either Low Light or UV, although Thermograph or Infrared can also be found.



NOMAD TREKMATE 29eb
(From Nomad Market)

Really nothing more than a handmade wheelbarrow/travois for hauling your goods wounded on foot. They can be invaluable if you have to hike long distances.



OAKLEY SMART GLASSES 1800eb

These normal looking visor sunglasses house any two standard cyberoptic options. Available in either black or mirror tint.



OAKLEY ARMOR SHADES 2500eb
 An armored version of Oakley Smartglasses, not only do they provide protection for your eyes (SP:10) but they have memory foam cushions to help absorb impact. The shades can have up to 5 options.



OUTBACK INDUSTRIES RAPPELLING WINCH 295eb
 These rappelling winches were designed by an ex Australian Special Forces member. They are completely silent, and have 200 meters of cable. The winch retracts up to a maximum speed of 10ft a second.



PARACHUTE- Standard parachutes and the HALO variety. Both models are invisible to radar and feature the regular backup in case the primary fails.



PARAGON SHOULDER PADS 120eb
 Football is a much rougher sport in 2020, and these pads are the pinnacle of comfort protection. (SP16)



PNEUMATIC STILTS 600eb
 These auto retracting stilts are a wonder. When not in use the stilts consist of leg braces with a rod attached, and can be concealed under the pant legs. When activated by pushing a button at the top of the rod the stilts extend and a small foothold pops out. The stilts extend out to 6 feet and are made of titanium, they are a half inch wide at the bottom and 2 inches at the base. be warned, they do take lots of practice to use.

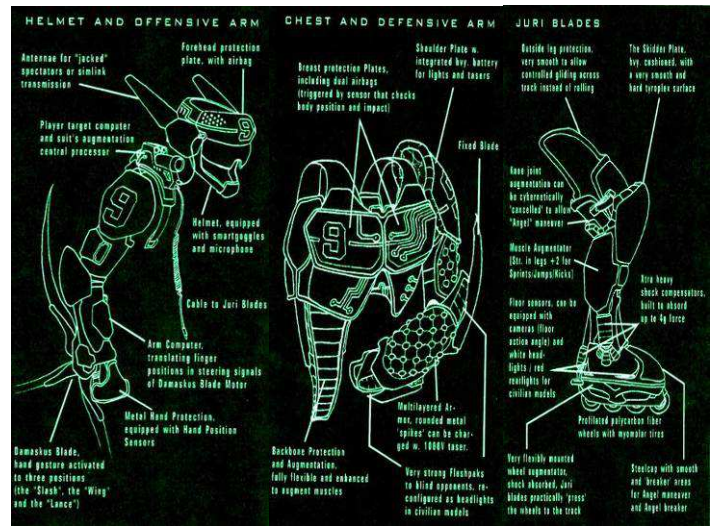

RABEN AAS MOTOBALL ARMOR 8970eb
 Up till now, Motoball was a sport exclusive to full conversion cyborgs. Not anymore, now even true humans (totally unaugmented) athletes can join the fun, not that anyone is recommending that they do. This armor/enhancement gear boosts the performance of normal humans wearing it. Using the same technology developed for Hardsuit power armor, the system is able to boost the strength of the user by +2,+4, or +6 (each +2 after the first increment costs another 4,000eb), and the powered skates boost the users top speed up to 50mph. In addition the gear gives an armor protection rated to SP: 18 with no substantial encumbrance penalty. It features both offensive blades and a defensive shield with a built in taser. And lastly, the headpiece features all the communications tech necessary for a runner to keep in contact with his support team in any environment. All this, plus its extremely intuitive and customizable. In addition to Motoball enthusiasts, this equipment, sans weaponry, has become popular with couriers and is even allowing non augmented humans to participate in Jattenhand.



ROPE AND GRAPPLE SET 300eb
 This set contains a carry bag, 200 ft 9.9mm high tension rope (1000lb), a rappelling saddle, climbing pitons, a silent piton driver gun, 5 pulleys, rappelling gloves, a personal braking system, a grappling hook with optional padded sheath to reduce noise, 12 carabiners, and various accessory cords. Available in flat black, soft white, or olive drab.



SANSUI ABLEOPTIC MONOCALES 200eb
 These self adhering monacles, available for either right or left eye, have space for 1 optic option each, often bought in pairs.



SEBURO COMBAT GOGGLES 1750eb
 Built in commlink, audio enhancement, armored to SP:8, with Thermograph, Anti-dazzle, Low-light, Times Square, and Tele-optics installed.



TRACCA MOTOCROSS HELMET 85EB
 A stylish motorcycle helmet (SP14) designed for off-road and trick riding. Available in a multitude of colors and graphics are available as well. For an additional 25eb you can buy a version with built in radio so you can communicate with your crew or teammates.



SHUTT FOOTBALL HELMETS 65eb
 The latest in sports head gear. (SP 10)



UTOPIC G-WHEEL 800eb
 This is a small two-wheeled motorized platform that rides much like a skateboard. Speed and braking is controlled via a handset or via smartlink. Gas operated it has enough fuel for about an hour and half and can reach speeds of 30mph. The G-wheel has limited off-road capability. A sportier version able to hit 50mph can be had for 3000eb, though it only has an operable range of half 45 minutes.



SWISS ARMY KNIFE 20-60 eb.
 It's a Swiss army knife. It has a variety of tools, including: cutting knife, saw blade, fingernail clippers, scissors, standard screwdriver, Phillip's head screwdriver, hook, leather punch, awl, can opener, bottle opener, spoon, fork, corkscrew, magnifying glass, toothpick, tweezers and nail file.



TEAM GAUNTLET 4,630eb
 Through these gauntlets you can constantly monitor your teams locations. Each gauntlet sends and receives a radio signal from each of the others, allowing you to know their exact distance, direction and even any difference in height from your position, all displayed in text and on a rotating 3-d map which shows up on the display screen of the gauntlet. If you have access to the blue prints or a map of the area you find yourself in, then the device becomes even more useful, as you are able to exactly coordinate each member of your teams position. The gauntlets are armored to SP:18 and can store up to 5 3-d blueprints or maps. Comes in two styles.

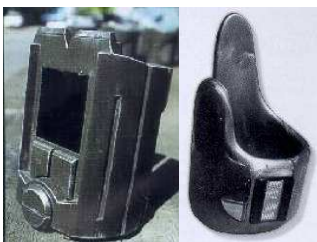

TOSHIBA "RABBIT EAR" ANTENNAE 60eb
 This antennae, which can be attached to any helmet, or worn on its own, doubles the range and clarity of any receiver/transmitter it is connected too. Up to five cyberaudio options can be installed. For an additional 100eb a retracting camera can be installed in the which when hooked into a times square enabled cyberoptic device on a helmet or goggles allows the user to look around corners safely.

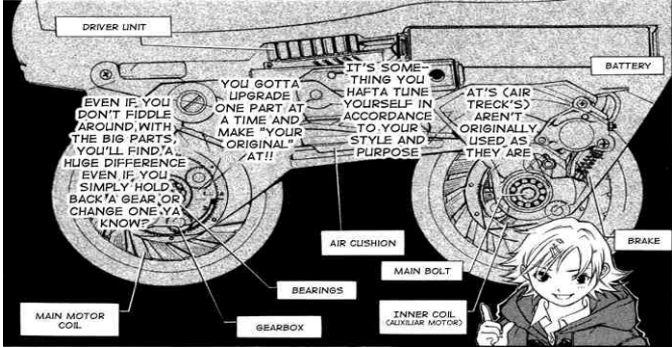

TREK ROLLER BLADES 1350eb

These motorized roller blades can reach up to 30 miles per hour, and can be controlled either via hand held unit or through wireless smart link. The skates can act as normal skates until the motor is activated. The battery for these skates lasts about half an hour, however by turning off the motor and switching the skates to “recharge mode” either manually or via smartlink, a resistance gear kicks in, and while the wheels spin normally, every time you push off you get a slight bit of resistance, this resistance charges the skates battery. You can also plug the skates in for 2 hours to recharge them.



WANDERER'S GAUNTLET 55eb

This enormously handy device is mass manufactured by Meta-corp. It is worn on the wrist like an oversized wristband, with the adjustable handle placed just on the outside of the hand so your hand remains free until it is necessary. The compartment on top has enough room to store the contents of your wallet and a few other small items, making finding change for a toll or retrieving your I.D. quick and easy. The handle and trigger activate an auto-hypo capable of storing and injecting up to 5 doses of the narcotic of your choice, though most opt for mild amphetamines to keep them awake and alert on long runs. This is a device no one on a bike should ever be without. For the more health conscious, the device is also available without the auto-injector for 30 eb less.

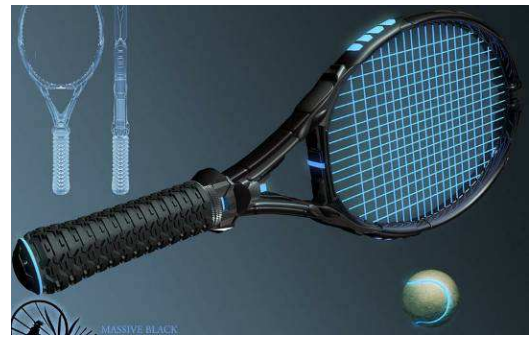

WILSON MASSIVE BLACK TENNIS RACKET 640eb

The Wilson massive black is the most well regarded tennis racket in the world, capable of making instant adjustments to amplify the users playing style (+3).



WUTANI PORTABLE POWER PACK 250eb

Providing up to 5 hours of power for regular output appliance, and easily rechargeable from any wall socket. If you can't afford the noise of a generator, and need to power something temporarily, this power pack is ideal.



YOUNGTECH BODY CONDITIONER 100eb

This is a harness system that holds weights, wearing it while training will help strengthen the body. Wearing this harness will reduce the amount of time it takes to build BOD based skills by half (IP earned towards those skills is doubled). However wearing the suit is uncomfortable and heavy, and while it is worn, all BOD, REF, and MA actions suffer a -4 penalty (the penalty doubles if the character is swimming, wearing this in the water is a good way to drown). To get the full effect, the harness must be worn during all waking hours, often under their clothes... on the plus side, the harness provides SP10 protection the forearms, waist, thighs, and lower legs, and +4 damage on kicks and punches.

MARINE GEAR

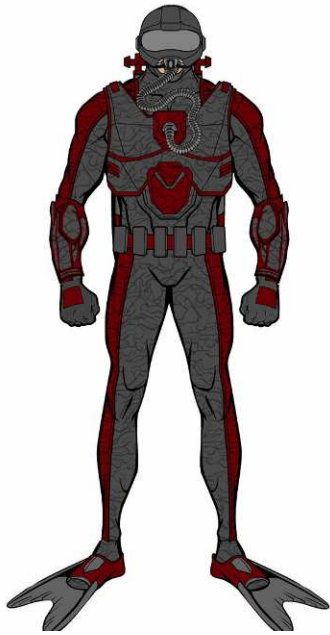

ARASAKA DARKWAVE 1465eb

The Darkwave is a lightly armored (SP6) stealth scuba suit that masks the user's body heat signature, keeping the surface of the suit the same temperature as the surrounding atmosphere. For an additional 1200eb it can be purchased with an active Color/Pattern Shift technology identical in function to that of the Militech Mirage gear or M-204 diving suit. The suit, in either version, makes use of an armored diving helmet identical in function and protection to the Arasaka Swordfish.

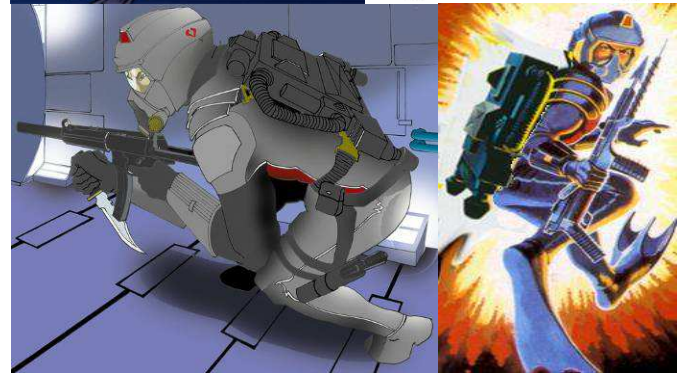

ARASAKA AQUA-STANDARD SCUBA GEAR 630eb

Arasaka standard underwater gear. The helmet itself acts as the diving mask and is armored to SP:15. While the suit features an extraordinary insulation system, it remains thin enough for full dexterity and agility.



ARASAKA EEL-12 ARMORED WETSUIT 859

This wetsuit is actually a thick, rubberized datafilm (SP:8) that will protect the skin from most things, however for extra protection it has a hard, but lightweight, torso shell (SP:14) with connection studs for either the Arakasak Armored Scuba Tank or the Mitsubishi Catshark pack. The suit was designed to be used with the Arasaka Swordfish diving mask.



ARASAKA PROPEL SCUBA TANK 400eb

This scuba tank has a 100 minute air supply. The more interesting feature are the twin adjustable waterjets located at the bottom of the tanks, that serve to propel the diver (10mph). The propeller is electric and requires 30 minutes to recharge. Speed and angle is adjusted by either a glove unit or vehicle smartlink.

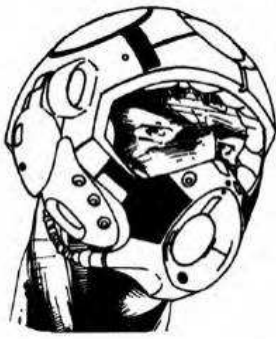

ARASAKA "SWORDFISH" DIVING MASK 495eb
 Consisting of an armored helmet (SP:15) which vacu-seals to the users head, this diving mask also features a waterproof helmet cam and optional rabbit ear transmitter/receiver antennae. The visor is depth and bullet resistant (SP:6) and is guaranteed never to fog. The mask works with any scuba apparatus, and has connectors on the mask itself for the air hoses. The mask also comes with its own rebreather filter, capable of independent operation without creating bubbles for up to 5 minutes. For an additional 200 eb, the visor can be equipped with 2 cyberoptic options.



ARASAKA TORPA ARMORED SCUBA TANK 525eb
 This SP:15 scuba tank is built from lightweight materials which are perfectly balanced and adjustable to provide the diver with neutral buoyancy while still providing 45 minutes of oxygen. The tank is of the rebreather variety and does not emit bubbles. The tank is also very streamlined allowing the diver more speed and maneuverability underwater, as well as allowing him to get into smaller areas.



EDF MILITARY SCUBA GEAR 490eb
 Identical except in appearance to Otec Scuba Gear.



KREIGER DIVING GLOVES 35eb
 There is a strong but ultra thin membrane stretched between each finger and thumb of these gloves, giving you an extra boost of speed and agility in the water, there are also nubs implanted on each of the digits to improve grip underwater. The gloves themselves are made from the same material as the membranes, and are custom fit to the wearers hands, ensuring they remain skin tight but comfortable. The membrane is stretchy enough to still allow you to fire a gun, manipulate a key board, or any other tasks which require manual dexterity.



KREIGER EMERGENCY REBREATHER 200eb
 This tiny rebreather contains 10 minutes of air for emergency situations, safe to 35 meters.



KRIEGER DIVE GEAR 520eb
 This set begins with a Krieger Aquaskin wetsuit, designed for comfort and agility. Krieger short fins, for quick maneuvering, a Krieger diving helmet with radio and built in lights, a Krieger Sharktooth diving knife, and finally the Kreiger Seapack rebreather, good for 2 hours with auto adjusting mixtures. This is the preferred gear of professional divers around the world. All itmes are available in a variety of colors and styles, and the wetsuit is available in long, short or no sleeves, and long short, or brief cut leggings.



MARINER SHARKSUIT 400eb

The surface of this suit is covered in micro scales emulating the skin of a shark, the scales act as a serrated edge, protecting the diver from grapple attempts by other divers or wildlife. (1D6/3 damage to anyone grappling you).

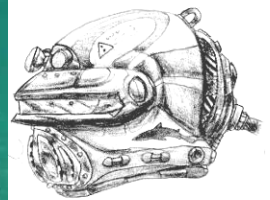

MILITECH SCUBA ARMOR 2535eb

With an armor rating of SP:18, this armor is popular for divers swimming in shark infested water, as well as combat divers. The armor is basically light metalgear, specially designed to have zero buoyancy.



MISTUBISHI CATSHARK PACK 3500rb

This diving pack mounts a caterpillar drive system onto the swimmers back, and 2 15 minute air tanks on the front. With this pack a diver can swim at roughly 20mph.

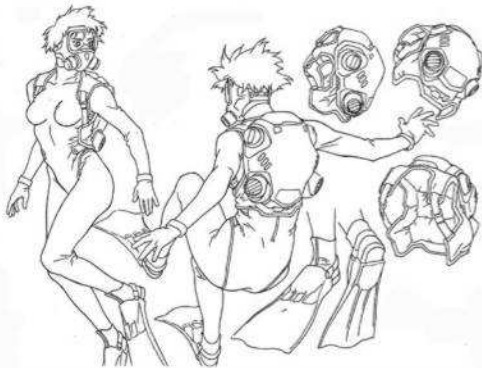

MILITECH M-402 STEALTH SCUBA GEAR 16,350eb

Using the same technologies as the Militech M-73 mirage gear (see chrome book 2), the M402 provides the wearer with ultimate stealth capabilities both below and above the waves.



NEO-SOV MILITARY SCUBA GEAR 400eb

Identical except in appearance to Otec Scuba Gear



OCEANIC MINOS DIVING MASK 1120eb

This dive mask has a built lights and a video recorder rated to a depth of 100meters with a 2 hour memory and Lowlight, image enhancement, tele-optics and micro-optic options. The visor of the mask features the same optics as well as a heads up display of the camera recording, playback, and times square marquee.

MEDICAL



BIO-TECHNICA ANTI BIO-CHEM SUIT 250eb

Folds up into a small pouch, fully sealed, 5-7lbs, fit into a 3 cu-foot bag and are about 1" in thickness, made of layers of filter material and activated charcoal. Extremely tear resistant, meant to be worn over clothes. (Note this suit will not stand up to blister agent attack for more than a few minutes, most other hazards and the suit will work for days under constant attack.



BIO-TECHNICA MANTIS EXO-SKELETON 6,150eb

Little more than a low powered linear frame, this exoskeleton, through cybernetic interface, uses electrical impulses to allow quad and paraplegics use of their bodies again. While most would simply turn to cybernetic replacement, that is not always an option or desirable.



BIOTECHNICA REALSKIN APPLICATOR 45eb

Available in Caucasian, Hispanic, Asian, Light African, Dark African, Indian, and Arabic, this is, in effect, spray on Realskin, used for covering up small tears and rips in a realskin covering on a cyberlimb. It is only recommended for small touchups, such as from a skinned knee, a knife slash, or a bullet hole, for which each can hold about ten applications. You use these small jobs the spray will thicken, bond, and adhere to the realskin seamlessly... the only noticeable difference is that it might leave a small discolored, hairless, and smooth scar where the new spray doesn't match up perfectly with the skin tone. For more severe damage you must go to a licensed cybertech.



BODYWEIGHT COCOON LIFE-SUPPORT POD 2125eb

This pod is filled with synthetic amniotic fluid, bio-monitors, sedative injectors, and oxygen supply. The pod is used to transport prisoners without the possibility of them being harmed or harming others.

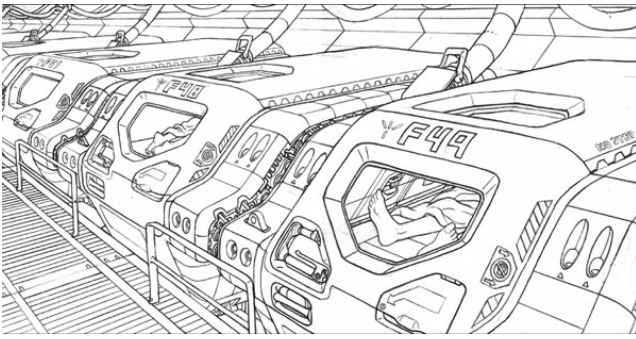

BODYWEIGHT STASIS PODS 145,000eb

Designed for the proposed mission to Mars, these chambers preserve and protect their inhabitants. Upon entering the chambers, the inhabitant is warmed while a mild sedative is pumped into the pod, medically inducing a coma. When the pod's sensors register the subject as being asleep, it begins its cooling process, dropping the temperature in the pod into a state of crystasis. Safe and unaware, and the subject can make the long trip and when the pre-determined time has elapsed, or in the case of emergency, they will be awoken. The pods also act as life support pods, and contain a radio beacon that will activate if the pod is ejected from the ship.



DYNALAR CYBERBRAIN 116,896,125eb

When it was discovered last year that there were GHOSTS in the net, downloaded personalities thought to be dead, victims of black ice, that somehow remained intact as bodiless entities free roaming the virtual universe, Dynalar technologies began the most ambitious project since the full body conversion. When they realized that personalities, memories, could be transferred out of the body and remain intact, they realized they could reverse the process. Originally they tried doing so with organic brains, clone bodies and coma victims, with some limited success, or least so the rumors go. Apparently they came to the conclusion that it would be a step backwards if after figuring out how to transfer consciousness, they transferred it into a brain susceptible to age and disease. So they began knew process. We aren't sure how they did it, we don't know how it works, but Dynalar has created the first fully functioning cyberbrain. At a far too high cost to our own organization, Autumn Blade acquired 2 of these. If you can afford one, what you do with it is your business. We do not know the process of downloading or transferring consciousness, only Dynalar's most highly placed developers know, and they aren't telling, and they haven't even gone public with their discoveries yet.

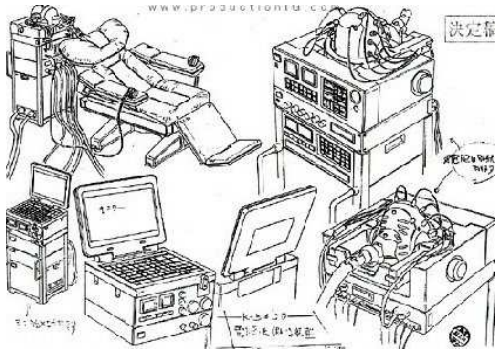

BODYWEIGHT "VAN WINKLE" LIFE SUPPORT SYSTEM 6,745eb

With this system an individual can remain immersed in the net or VR SIM for up to a week at a time. It monitors all vital functions for irregularities, and at the signs of danger it brings the user into full consciousness with a dose of stimulant. In event of emergency or failure to bring to consciousness, the system automatically places an emergency call to trauma team.

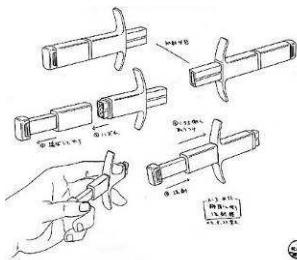

BODYWORKS DNA SAMPLER 10eb

This device is used by police and medical personnel to retrieve DNA samples. The safety cap, working like a pen cap, is removed from the front, attached to the back and works as the plunger. When depressed, 10 tiny quarter-inch needles puncture the skin, drawing the necessary sample into an interchangeable reservoir.



LIFEWORKS DEFIBRILLATOR GUN 425eb

Sold and used in pairs connected by wire, these are used by EMT's to issue an electric charge to resuscitate a body. Each par holds 10 shots, and can be recharged from any wall socket in 2 hours. Additionally you can plug the units into the wall to use them, which gives them unlimited charges. (Using these gives a +4 to revive someone who has been dead under 2 minutes).



MICROGEN MEDICAL NANITES

ANTI-CANCER TREATMENT- of extreme use to highriders, and anyone working with questionable substances. The anti-cancer gene is a monthly nano-tech treatment which scours your body for cancerous cells and eliminates them, breaking them down into waste for your body to purge. No more being afraid to walk outside, even in the rain, drink the tap water, and now you don't even have to give up smoking. Monthly treatment costs 50eb.

CHOLESTEROL SCRUBBERS – These nanites will more through the bloodstream to the heart, and remove cholesterol building up around the heart. 85eb per treatment.

FAT REMOVAL – These nanites must be applied by a licensed physician and must be monitored throughout the process. The nanites in injected directly on the effected area, where they will go to work breaking up the fat cells, where the body will dispose of them as a thick oily waste. If the process is not monitored there is a chance that the nanites will go too far, and begin eating the body fat the body needs to survive. Because of this, the subject must check in to a licensed clinic for 4 days, and they will only perform the treatment once a month. Each treatment will effectively rid the subject of 2d10 lbs per treatment. After this occurs, a second nanite treatment is applied to the same spot, which will tighten and rebond the skin. Black markets purchases of this nanite treatment allowing users to self treat can end are popular, but all too often end in disaster (10 percent chance per treatment of doing 3d6 points of damage, BTM does NOT apply, this chance doubles if the subject is already within 20lbs of ideal weight, and triples if they are under their ideal weight). Each treatment costs 200eb +1000 dollars for the 4 day stay to be monitored. The nanite treatment alone can go for up to 200eb on the black market.

ORGANIC WASTE SCRUBBER- with this weekly dose of nanotech, your feces will no longer smell bad, in fact it will now have the pleasant smell of baby powder. This is accomplished through a nanotech suppository which further breaks down the solid waste in your bowels and eliminates the foul odor before it leaves your body. So even your farts won't stink. A side effect is that your feces will now be comprised mostly of a wet powdery substance, and you might experience cramping after eating certain foods. Weekly treatment costs 35eb.



MILITARY FULL FIELD MEDKIT 650eb

Everything you could possible need, for everything from simple first aid, to full blown combat surgery is included in this kit. It includes: First Aid Systems for eating/Preventing: CPR - with CPR Lifesaver Pack with CPR Microshield and smelling salts, Fractures/Dislocations/Sprains - with Sam Splint and Elastic Bandage, Hypoglycemia/Insulin Shock - with Glutose Paste Dehydration and Oral Rehydration Salts, Dental Problems - with Dentemp Temporary Filling Mixture, Snake Bites & Bee Stings - with Sawyer Extractor and assorted antivenins, Wounds - with Irrigation Syringe & Scrub Brush, Blisters - with Spenco 2nd Skin and Molefoam, Burns - with Aloe Vera Gel, Trauma - with Trauma Dressings, Wound Closure Strips, 4 cans spray skin, and Triangular Bandages, Allergic Symptoms - with Antihistamines, Virus Transmission - with Infectious Control Pack, a full assortment of trauma drugs and painkillers (10 doses speedheal, 10 doses morphine, 10 doses Trauma, 5 anesthetic slap patches, Eye Wash, 30 minute can of oxygen, and 6 vials of other assorted drugs), plus the following Medical Instruments: EMT Shears, Splinter Picker Forceps, Hypothermia Thermometer, Hyperthermia Thermometer, Scalpel, dermal stapler, 4 inflatable casts, medscanner, airhypo, auto-medic, Blood Pressure Cuff, Stethoscope, Mini Mag Head Light, 18-gauge Plastic Catheter,



MITSUBISHI EXSELCIOR POWERED CHAIR 22,395eb It's a wheelchair, its a one man city car, it's both. This chair has a top speed of 50mph and runs on electricity and CHOOH2 (which it automatically switches to when battery capacity reaches 25% or when the vehicle exceeds 15 mph). In normal "tall mode" the chair acts just like any other power assisted wheelchair (max speed of 10mph) and even has the ability to climb stairs, albeit slowly. In extended mode the chair is able to make full use of its speed and power. For an additional 200eb the chair can be smart link equipped.

COMPUTERS, CYBERDECKS AND COMMUNICATIONS



ALTEL STANDARD DATATERM 800eb
When renovating Nakajimo towers, Autumn Blade found itself in possession of 10 dataterms.

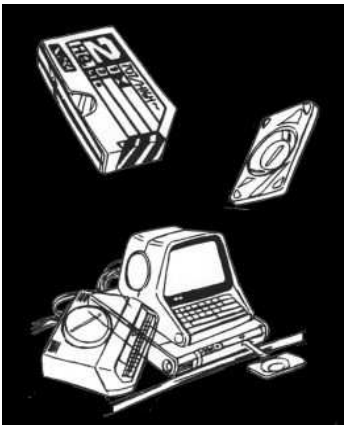

ARASAKA INFO THIEF 2985eb
This electronic device will completely copy the entire contents of any personal computer in under ten minutes, and leave no record of its intrusion. It will also download the information into a new computer in the same amount of time. Warning, before downloading onto a new computer, it will first wipe it clean to make room for the data.



ARASAKA/SONY KAMUI COMPACT 16,575eb
The memory isn't the best, and it doesn't offer the most protection, but this is the most compact cybermodem available on the market, it's also very fast (+3, 15 MU, +3 DW, cell). And, for convenience sake it also doubles as a wristwatch and phone.



ARASAKA/SONY HOKURA 7 COMM GEAR 41950eb
The latest full feature military mobile communications unit. 200 mile range, full shielding, jam and scramble capabilities, and any other feature you could think of are all incorporated into this unit. All the controls and display are built into the Comm helmet, allowing instant communications in the field, the helmet also features a full military cybermodem, Sony 's equivalent of the Microtech CAD-4 Commando (see Rache Bartmoss's Brainware Blowout for more info). The back-mounted com system has a detachable wireless handset for direct officer communication.



Ono Sendai

- Flip up and pull apart monitor from flexible LED technology.
- Touch sensitive keyboard areas, with nanotechnology. Buttons rise from the surface to provide haptic feedback.
- Custom key arrangement for maximum ergonomics.
- Flip case at front hides jack-in-plugs and earpiece on retractable cords.
- Handle on rear for easy mobility.
- Fully integrated wireless cyberspace fusion, access, and processing.

ARASAKA OPERATIVE "PIGGY BACK" SYSTEM 495eb
This device comes in the form of a transmitter implant, and allows commanders, and or the team netrunner to monitor the troops through their own cyberoptic, and cyberradio implants. Range is 3 miles. Transmitter implant costs 250eb HL-0 and minor surgery (it just hooks into your neural processor). (A more advanced version is under development which will hook directly into the brain, and allow the "stowaway" to monitor through the visual, audio, and tactile centers of the brain itself.)



ARTEMIS A-MOD 10500eb

A decent cybermodem(+2, 20MU, DW+5, cell), perfect for beginners with plenty of room for easily slotted upgrades.

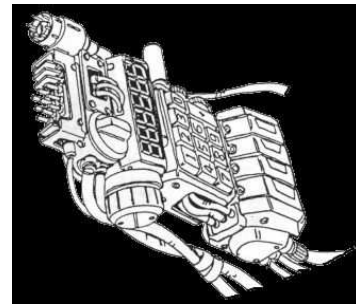

DATATEL FREQUENCY SCANNER 7500eb

This monitors all available airwaves, including radio and cellular, and is used to listen in find and monitor enemy transmissions. Although it will find all active channels and monitor them one at a time until you find the one you are looking for, it works best when you have a recording of a persons voice that it can match. Absolutely invaluable on a battlefield, as it will allow you to hear the commands being issued by enemy forces.



AZTECH LONG RANGE RADIO 15,500eb

The latest full feature military mobile communications unit. 160 mile range, full shielding, jam and scramble capabilities, and any other feature you could think of are all incorporated into this unit. It also features a detachable full military cybermodem, and a removable Mexican military microcomp.



DATA-TEL MORPH 650eb

It's a phone, a wristwatch, and a tablet all in one. The latest innovation from Data-Tel's soft screen tech is an amazingly versatile piece of equipment. The screen itself is bracketed at each end by segmented joints, so while in its base form it is a flat, very thin tablet, the frame allows it to be folded into a small handheld unit that works perfectly as a convenient phone shape, or folded in curves longwise to wear as a "slap band" watch. A removable ear piece ties the entire thing together.



B.A.C.L. Electronics LONG RANGE RADIO 8560EB

This is the state of the art radio telephone used by EDF forces. 300 mile range, full shielding, jam and scramble capabilities, and any other feature you could think of are all incorporated into this unit. It is 20 pounds lighter and connects directly into a specially built helmet (sp:20 sdp: 10) for the RTO allowing hands free operations for most situations.



DATATEL POCKET MONITOR 150eb

Everyone loves the versatility of the WSC Flopscreen. But keeping them clean and undamaged can be a pain. The pocket monitor uses the same technology, albeit in a smaller package, puts the system into a retracting scroll case for protection and convenience. When opened, cross bars lock the screen in place, insuring a clean sharp clear image.



CHINESE SURPLUS FIELD RADIO 7950eb

No where near its modern counterparts, this is a simple long range military radio bought in bulk from China.



DATATEL POLICE FLASHCOMP 50eb

This simple device is little more than a cheap flash drive with a view screen. Police use it as a display for photos, warrants, special notes, and personal voice recorder.

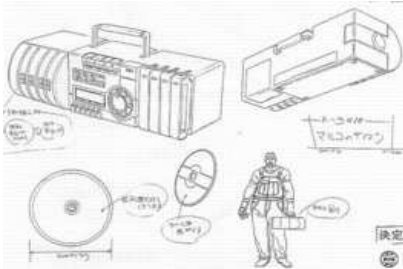

DATATEL PORTABLE INFOSTORAGE/COPIER 500eb

This device about the size of a boom box allows for massive data storage, and copying onto any medium desired.



DATATEL WRIST UNIT 250eb

Combining a GPS, a tablet, and Datatels floppy screen technology the Datatel Wrist unit is everything a busy person needs to find his way, co-ordinate plans, keep up to date, or just relax on the commute. Built in A/V players plays all popular digital formats, and the device has enough storage space to make it all worthwhile.



EBM PNI 724 (MILITARY) 15,000EB

This is the military version of EBM's top of the line cyberdeck. It has all the features and capabilities of the civilian version, but has an armored shell to protect against damage from rough use. (see Rache Bartmoss's Brainware Blowout for more details) It is specially designed to hook into the B.A.C.L. Electronics Long Range Radio, and because of the specially designed helmet a soldier can switch back and forth between the net and real time without losing his or her place as well as having a small visual readout of his net position displayed on the helmet in real-time.



ELF INC. PHONE JUMPER 36,540eb

Never pay for another phone call, and never get caught again. The phone jumper is a miracle for netrunners, and anyone else who needs an untraceable phone line. What this device does is two fold. First, by attaching the device to anyone's cellular phone, and then by calling a special number (which is actually a military satellite) the device records the cell phones frequency and exact registration. The device can store up to 300 cellular service registrations. This means that you can make calls using other peoples phone service, all you need is two minutes time with their cell phone. The second interesting use of this device is that anytime you make a call, as soon as the numbers are dialed, the device instantly opens five other phone lines (as if you were talking on a party line or three way). This way the phone call is completely untraceable, as any attempts to trace the call will reveal 5 different locations and owners. As an added bonus, if someone whose service you have "jumped" picks up their phone while you are using their service, the device will immediately hang up that line and replace it with another, you can even set it to simply rotate through your stored services. The Phone Jumper obviously acts a regular phone. For netrunners this is where the gold truly is, as due to the multiple lines, it is almost impossible to become the victim of any trace attempts or black ice programs. (With black Ice there is an 80% chance of successful avoidance.) Of course any trace attempts will reveal the true service owners number, who will most likely be questioned at the very least, so using your friends cell service is not recommended.



GIBSON TANDEM CYBERDECK 11,320eb

Pretty much self explanatory, this deck allows two or more netrunners to use the same deck to make a run, allowing them to concentrate their capabilities and resources, as well as watch each others backs without fear of becoming separated or lost. The deck has a whopping 45 MU, SPEED +3 and +3 DATAWALLS. It also comes with a display screen, allowing the rest of your team to monitor your activities.

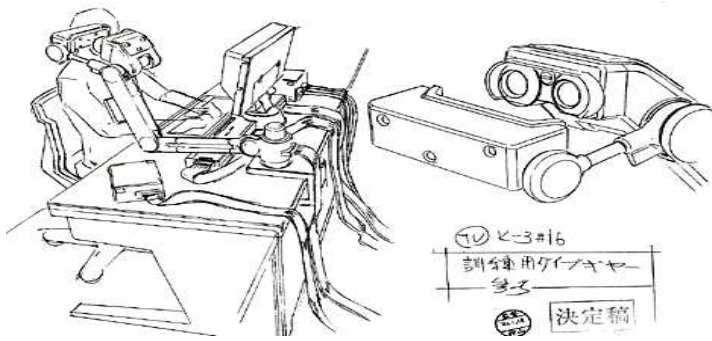

KIRAMA RETINAL SECURITY MONITOR 350eb

This device may be a bit bigger than it needs to be, but for anyone needing to view classified information, it is absolutely invaluable. Once a persons head is in place, the view piece first scans the persons retinas, once the check has succeeded, the information is released into the view piece. If the persons head moves from the brace for even an instant, the open information closes immediately, making it impossible for anyone but authorized personnel to even get a glimpse. Also, each and every screw of the apparatus is wired into the computers security system. Any unauthorized tampering results in instant data wipe of all files marked sensitive.



KIRAMA VOICE AND VISUAL CONTROLLED REMOTE OPERATOR 1235eb

By simply plugging in the receiver into any vehicles smart link and attaching the domed camera to any surface of the vehicle (preferably one that gives you 360 of vision around the vehicle) you can assume complete control of that vehicle. Visual and auditory image from the camera are relayed to the goggles, and the laser retina reader on the goggles controls camera movement. The earpiece and microphone are used to transmit audio commands such as slowdown, speed up, hard brake, etc.. as well as controlling any options the vehicle might have. A cyberlinked version of the transmitter kit is available for 500eb more, eliminating the need for goggles and mic.



KOBAYASHI "CATCHERS MITT" DATAGLOVE 63,920eb

What this glove, which covers the full arm, does is simple. It intercepts data (range 200 meters) as it is transmitted via wireless connections. It can be set for 3 modes, the first two allowing it to "catch" either cell phone communications, or data transfers. The third mode lets it use the datastream as a homing beacon, allowing it to track data to the source of either transmission or reception, but only while the connection is open. The gloves dual harddrives allow it store up information it steals. The problem with the Dataglove is that it stores any and all information being transmitted in the area, so you have to manually monitor the incoming information (Library Search skill role 20 with modifiers depending on amount of data traffic at any given location and time) of to disseminate a target transmission if you are looking for something specific, or wanting to track a datastream to its source. It was originally developed for FBI and police, but it's use was quickly deemed an infringement of privacy in the US where it was banned. Other countries with less compunction use them frequently.



MENSATECH VR EDUCATIONAL SYSTEM 256,000eb

Generally available only to the military, high level corporations, and orbital environments, the VR Educational System will tech the basics of any intelligence based skill in under 6 hours. To use the device one must don the helmet and jack into it, then through the ultra speed of interface the information is downloaded via VR training center into the students memory. This is an expensive but very efficient way to learn any new skill, and unlike certain skill chips the knowledge will not be lst upon removal from the system.. Learning programs cost an addition 200eb each and cover just about any skill you can imagine. (Learning non-intelligence based skills is possible, however the device will not train your body how to do them, only your mind. For example if you learn a martial art then you will be able to recognize and explain the moves, but not perform them because while your mind understands them your body does not.) (Skills can be learned up to a 3 with the VR Educational System.)

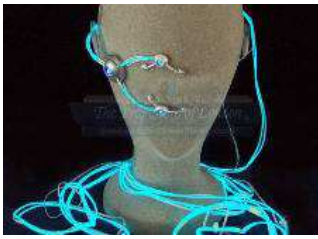

MICROTECH DATALINE CABLES 250eb
 These high performance interface cables provide unparalleled interface speed (+3 to interface rolls).



MICROTECH FINGERPRINT SIGNATURE DEVICE 145eb
 This small device plugs in to any computer and lets you use your fingerprint as a digital signature, to verify sender identity for sensitive documents and transactions, and as a passkey for your personal electronics, encrypted files, web sites, or even as a passkey for doors and other locks... it's much easier to hide a USB port than a scanner or key pad. The device not only reads your finger, but also checks temperature and pulse, so no one can just remove your finger and use it. The USB cord is retractable and the device is small enough to attach to your keyring.



MILITECH "THOMPSON" LONG RANGE RADIO 27950eb- The latest full feature military mobile communications unit. 200 mile range, full shielding, jam and scramble capabilities, and any other feature you could think of are all incorporated into this unit. It also features a detachable full military cybermodem, the Microtech CAD-4 Commando (see Rache Bartmoss's Brainware Blowout for more info) and a removable military version of Teletronics "Black Book" microcomp (see Rache Bartmoss's Brainware Blowout for more info).



MISTUBISHI COMMUNICATIONS ARRAY 24250eb
 100 mile range, full shielding, jam and scramble capabilities this set also features a helmet style(SP:15) (SDP:5) full military cybermodem, (equivalent of the Microtech CAD-4 Commando, see Rache Bartmoss's Brainware Blowout for more info) and a removable version of Teletronics "Black Book" microcomp (see Rache Bartmoss's Brainware Blowout for more info)



NOMAD CYBERMODEM varies
 (From Nomad Market)
 Nomad cybermodems are like anything else in the nomad community, cobbled together and made for the users requirements. While there are high end superfast cybermodems in the nomad community, most don't even have view screens. In fact, most nomad cybermodems are still made to only connect via phone line, as service in the wastelands is almost nonexistent. The best versions have their own direct satellite connections, but even then cloud cover renders them useless, (Players talk with you gm about fashioning your own cybermodem, but remember that spare parts can be hard to come by when you are outside of static society)



NOMAD EDUCATOR STATIONS 2485eb apiece.
 (From Nomad Market)
 These large, bulky stations are a teaching tool for large nomad families on the move, or even for smaller families who have the space and can afford one. Education is very important in the nomad community, but sometimes the adults are necessarily busy, especially on the move. Pop one of these puppies in your bus or van, and let the kids learn. The systems teach up to a basic high school lesson plan, though you can supplement that with additional teaching plan datadisks.



THE NOMAD SCANNER 450eb
(From Nomad Market)

This device automatically scans up and down all broadcast wavelengths civilian, emergency, and military, automatically pinpointing active signals and then displaying a list of all active signals being broadcast. By listening to the signal and selecting it, it will even tell you what direction the signal is coming from. With three of these devices you can even triangulate the signal to its exact coordinates.

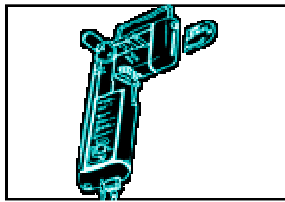
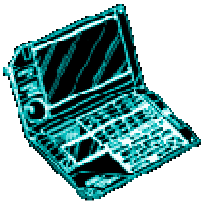

ORWELL PLAS CARD COPIER 375,895eb

With this device you can copy exactly any card (credit cards, ID cards, security pass cards, etc.) inserted into the card scanner, including digital information stored on the card. The laptop computer registers and filters all the information on the card, and even allows you to edit the new card, such as to put your picture on the card in place of theirs, or your DNA/blood type, or whatever. The device can even attempt to copy any imperfections on the card itself, such as rubbed off ink, scratches, holes, or whatever. This device is incredibly expensive, but well worth the price.



PIXY UNIVERSAL REMOTE CELLULAR PHONE 675eb

This phone flips out to reveal a small LCD screen and a universal remote key pad. You can use this to control any remote control operated device, from your TV, to your security system, to an RPV. The screen can even be used to display camera footage from your security system or the RPV you may be controlling. It of course also works as a standard cell phone.



RAVEN MICROCYB PK-105 BONEHEAD 36,250eb

This is the armored (SP:16), fully enclosed version of the PK=105 Dataowl. It fully encloses the head, provides a filter system in the event of airborne contamination, and can seal itself with a 5 minute supply of oxygen. The helmet comes with Times Squares Marquee and HUD, as well as room for up to 5 more options. It is also has a built in radio and room for 4 audio options. This is a very high end unit, very popular with street culture, often customized heavily.

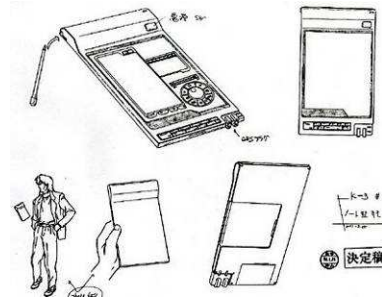

RAVEN MICROCYB DATA CLIPBOARD 200eb

Used by companies the world over, these clipboards feature infinitely programmable touch pads and can display anything from company forms to tracking orders. At the end of the day they can be slid into central processors to download and share all relevant information and updates. They used to contain modems allowing them to connect to the company mainframe, but netrunners were having field days with them.

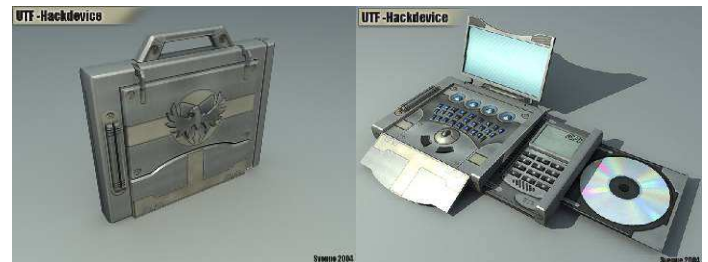

RAVEN MICROCYB DATAHAWK LAPTOP 4345eb

The best laptop on the market today. Raven will customize it to suit any users needs at no additional charge.



RAVEN MICROCYB GO-COMP 4695eb

The problem with laptops and portable computers is that they lack the power and storage capability of desktop units. This has all the power and capacity as well as the multimedia functions of a desktop, but allows the portability of a laptop. It comes with mounts allowing you to attach it directly to a jacket. Also comes with wrist mounted key board and a set of Monitor Shades for real time, on the move, accessibility.

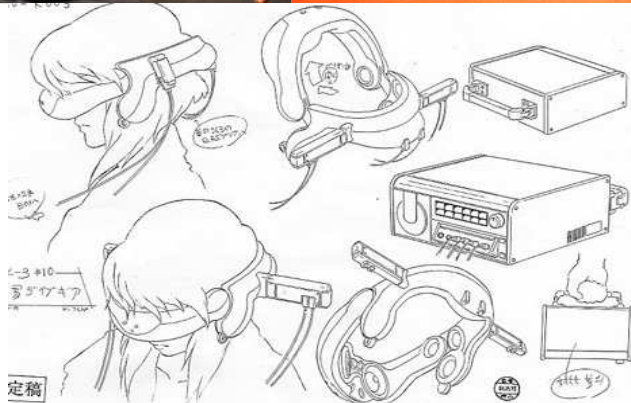

RAVEN MICROCYB "MOTOKO" COMBAT MODEM

42,455EB
(+5, 30MU, DW+7, cell)

The latest combat cybermodem from Raven. In addition to the armored (SP:10) housing on both the modem itself and the flip down VR goggles (for safe work), this cybermodem is state of the art utilizing the most advanced processors. The unarmored non-combat version is available for 38,000eb and is otherwise identical.



RAVEN MICROCYB PK-101 DATACOWL 34,750eb

Fitting over the head like a helmet, this high-end cybermodem (+4, 35MU, DW+6, cell) offers a constant direct connection and seamless drop-in/drop out interface.



RAVEN POLICE ISSUE FIELD CYBERDECK 32,487EB

This is the cyberdeck (+4, 25MU, DW+6, cell) issued to Netsec operatives for field work, a top of the line cybermodem that fits over the head like a visor, plugging directly in to the operators smartlink.

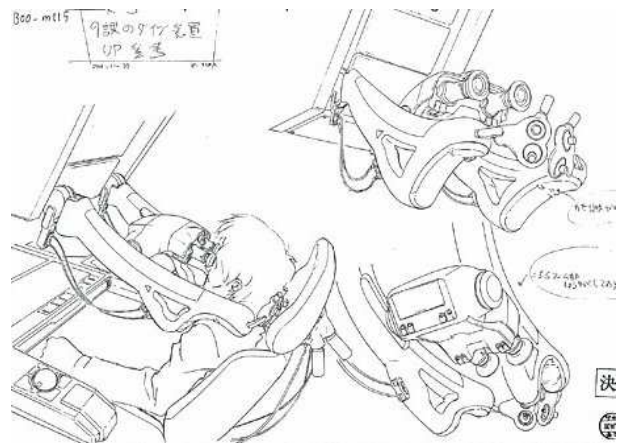

RAVEN MICROCYB TOTAL IMMERSION REMOTE OPERATING SYSTEM 85,725eb

Why put forth the money and resources to outfit one person with a full body conversion? Why risk all that time and money going cyberpsycho and giving the company a bad name while C-SWAT flushes your investment down the drain. Well waste money no more. Now anyone can control a full conversion shell by remote. By jacking into this system, you get the full sensory experience of being the full conversion, without the risk. As long as you are jacked in, you are the full conversion. For the system to work, the desired empty shell full conversion package must be outfitted with a special receiver system. The military ramifications of this are obvious.



RUSSIAN LONG RANGE RADIO 27950eb

The latest full feature military mobile communications unit. 200 mile range, full shielding, jam and scramble capabilities, and any other feature you could think of are all incorporated into this unit. It also features a detachable full military cybermodem, (Russian equivalent of the Microtech CAD-4 Commando, see Rache Bartmoss's Brainware Blowout for more info) and a removable Russian military version of Teletronics "Black Book" microcomp (see Rache Bartmoss's Brainware Blowout for more info).



SATELLITE RADIO RECIEVER/TRANSMITTER 1685eb
(From Nomad Market)

Fully functioning mobile long range military radio, and cybermodem. This radio picks up everything, forget Ham, forget short-wave, this radio even lets you communicate with people in orbit, provided you know someone up there to talk to.



SGI TECH ELIZ-BETA 6120eb

A low end cyberdeck (+2, 25MU, DW+6), popular with teenagers wanting to try their hands at netrunning without getting over their head, or beyond their wallet. Focuses on safety and security, rather than high end speed.



SONY VIZORDECK 25,450EB

A very lightweight but fast visor style cybermodem (+4, 15MU, DW+5, cell) with an interesting twist, the normally transparent visor serves as both shades and an inward projecting display, but while netrunning the operator can project their POV on the outward surface of the visor, allowing his teammates and colleagues to monitor their activities in netspace.



SONY MASTER OPERATIONS SYSTEM 65,785eb

This elaborate and complete computer system will was specially designed by security experts, Net-Sec operatives, and High Level computer programmers to fill virtually every need you can imagine. The system has its own military grade state of the art cybermodem (+6, 35MU, DW+9, cell) , a full audio visual editing suite, and remote uplink system, and virtually every gadget and option you can think of. It was all designed to be completely modular and upgradeable, so you never have to feel left behind by technology again. It is somewhat portable and can operate via wireless hub, satellite link, or for maximum speed hard linked cable. There is even an old-fashioned dialup connection in the extreme case where no other service is available...



SOVIET SURPLUS RADIO TELEPHONE 360EB

China still relies heavily on Russian surplus, and this obsolete RT still serves the chinese army well.



SONY DATATUBE 12,370eb

This all in one portable computer is the one of the most sought after personal electronic devices in years. At first glance, it is little more than an odd looking tube, similar to the kind used to hold posters. But the truth is, the Datatube is a combination of powerful laptop, media device, and cybermodem (+4, 30MU, DW+6, cell) all rolled into one. Using floppy screen technology, the monitor and keyboard unroll from the device like measuring tape. The device also comes with a wireless mouse and webcam, both of which are detachable and the camera, which records both audio and visual, and is equipped with lowlight, teleoptics and image enhancement, can be worn on the wrist like a watch. The tube itself is hollow, which allows both for a more efficient cooling system, as well as a louder and deeper speaker array, allowing for true stereo sound. The strap itself doubles as peripheral points, while the cybermodem jack plugs into the back of the tube. The surface of the tube itself has a secondary small vidscreen, allowing media or website browsing even while the device is compacted. For dusty or otherwise adverse environments, the tube can be sealed at both ends, but be careful as this may cause the unit to overheat.



ZETATECH POLICE ISSUE CARD READER 325eb

This hand held device reads any ID card, displaying the information and connecting to the police database via the cars computer and transmitter and compares the data for warrants, subpoenas, etc.. It is also capable of reading fingerprints through the screen, and taking a breathalyzer analysis.

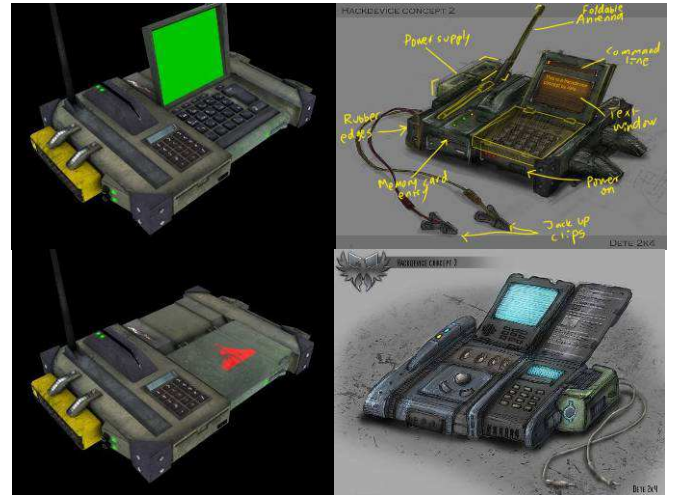

ZETATECH Z-RDM55 and RAVEN MILMOD-60

920eb/980eb (+4, 25MU, DW+7, cell) Military surplus cybermodems, virtually identical but for cosmetic differences.



ZETATECH MASTER WORKSTATION varies

For only the most serious and skilled operators, the Zetatech Master Workstations offer a complete streamlined package managing all your computing needs into one immersive station, giving you access to everything within arms reach. The price of the station is that of all the equipment you wish to have included plus the number of options you wish the works station to contain... lighting (20eb), operator ventilation and climate control (200eb), amount of additional work surfaces (10eb each), microwave (50eb), small fridge (30eb), adjustable seats (seat length, height, recline, forward back axis, warming and cooling, vibrating, (250eb)), Life Support System (6000eb), rotating base (50eb), and much more.

SURVEILLANCE, INVESTIGATION AND COVERT EQUIPMENT



ARASAKA BUG SCANNER WATCH 320eb
This otherwise normal looking and functioning watch has a secondary function and display that not only detects all transmitting devices within a 20meter radius, but gives direction and strength of signal as well, allowing the owner to find any listening devices or tracers within range.

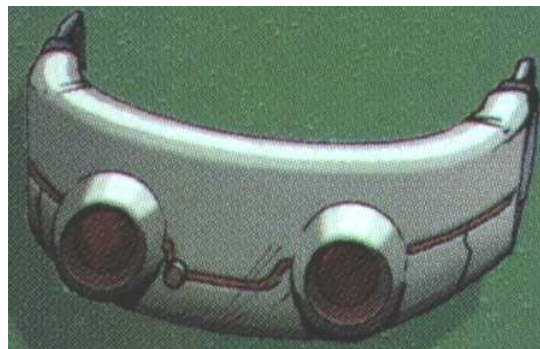

AUTUMN BLADE SECURITY DATAVISOR 670eb
This visor was created by Autumn Blade at the behest of Jacque Dubois. Its use is simple, but remarkable. First you acquire and download all data on blue prints and security devices of a location you plan on infiltrating. Once downloaded into the visor, it creates a 3-D facsimile of the location allowing you to move through that location with large glowing icons where security devices (cameras, motion sensors, laser tripwires, etc..) are located. When the monitor is switched off, or in standby mode, the display becomes transparent, allowing you to look through the two lenses. In addition the visor is equipped with IR and Low Light cybernetic options.



ARASAKA SICARIUS SMARTHELMET 1560eb
Named after the six-eyed Assassin spider, the Sicarius smart helmet features 6 optics all of which feed and display into the HUD display of the to lenses over the eyss of the wearer. Each lens can equip 4 cyboptic options, for a total of 24 options in all, though HUD in both central lenses takes up 2 of those total options. The options can be cycled manually via switches on the helmet, or can be controlled via smartlink. In fact, the helmet not only pulgs in to any available smart link system, but comes equipped with its own smart link ports, which not only allow the helmet full interaction with them, but allows users without smartlink to at least get the visual options available from weapon and vehicle links. In addition the helmet has a built in communicator, and can boast up to 8 cyberaudio options. All this in a comfortable half helmet with a rated SP: 18 protection level.



BIEHN HAND HELD ECHO-LOCATION DEVICE 450eb
This device uses a sonic burst to map terrain and objects in an area (just like a bat). It has a range of 50 meters and displays the image returned on the screen, or if you have interface plugs and the correct processor, it will display the information directly to your cyber optic. (Treat as a smartlink, the processor is 125eb.)



BIEHN BLOODHOUND TRACKING RECEIVER 450eb

The Bloodhound is a wristwatch with a secondary function simple digital view screen that acts as the receiver for any tracking device whose frequency has been programmed in, with a memory capable of storing up to ten separate tracking devices. The device can receive the tracers signal for up to 2 miles. The device will reveal direction and distance. Direction is obvious by determined by location from center of the grid. The upper right hand corner of the watch has 4 red LED lights. If 1 is lit, the tracer it is tracking is a distance measured in increments of 50 yards. If 2 LED's are lit, the unit of distance represents 10 yards. 3 lit up and the distance is measure in yards, and finally all 4 LED's illuminated means the distance is in feet.



BROSNAN SHOE ESCAPE KIT 150eb

Available in a wide variety of men and women's dress shoes and also most combat, western and motorcycle boots. A hollow heel contains a 2 foot long strip of det cord, an igniter, a small knife/screwdriver, monowire garrote, and a miniature flashlight. There is also a six inch plastic knife in the sole of the men's version.

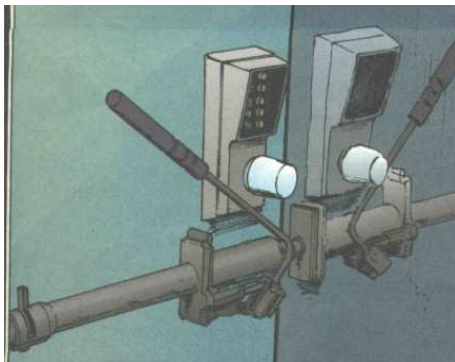

BOURNE INDUSTRIES DOOR SPREADER 500eb

This simple pneumatic device is placed on either side of the door jam, then activated. The bar extends forcing the doorjamb to widen, allowing the door to be opened.



CONSTITUTIONAL ARMS ION CUFF 225eb

The same as those issued to police, though a little more stylish, and not confining. This weapon shuts down all cybernetic options in the limb, and limits strength to that of a body rating of 5, for any limb it is attached to for as long as it is attached. This version is the one commonly used by airport security. Once in place it can be removed by inputting a specific code (extreme difficulty to crack) and by unlocking it with a special key. The airport security version of the bracelet will disable itself on its own after 24 hours, at which point if it has not been removed properly, it will begin emitting a homing beacon. This is in case of a crash landing in a remote area.



CONSTITUTIONAL ARMS ION COLLAR 895eb

Similar in function and design to the Ion Cuff, the Ion Collar is for individuals with Full Conversion bodies or otherwise extensive cyberwear, limiting their strength to 8 and preventing the activation of non-essential options and augmentations. Like the Ion Cuff, this is otherwise non-confining and is used mostly by Airlines and other agencies and corporations where safety overrides personal concerns.



CONSTITUTIONAL ARMS PNEUMATIC BATTERING RAM 1025eb

Developed for SWAT and other tactical teams, this pneumatic powered battering ram makes it possible for only one man to break down a door that would normally require 4 men with a traditional battering ram. It's heavy, and it leaves one hell of a bruise, but it is very effective. (Using this device inflicts 1D6/2 points of bludgeon damage on the user, and the user must have a min BOD of 6 or be knocked down when using it.)



CRUISE COVERT NANOTECH AND APPLICATOR
 Nanotech has unlimited uses as we all know, from cleaning sprays to cybernetic enhancement, the following are a few nanotech sprays that some of the more devious minds have come up with. The applicator costs 5eb.



SUPER SLICK- this nanite spray when applied creates an absolutely frictionless surface. Originally designed as an industrial lubricant, the spray is so successful that absolutely nothing can stick to it. In testing they sprayed the four walls of a fish tank with Super Slick, and then inserted a variety of creatures, such as frogs, ants, and spiders, into the tank, none of them could climb the walls, even after a 45 degree incline was added. In other tests, the applied surface was laid flat, and onto it was poured wet sand, oil, even thick maple syrup, and left to dry. When they lifted the surface, every thing slid completely off, leaving the surface without a trace. Super Slick can only be removed with a special solvent, (10eb) and will otherwise last for 6 months before the substance breaks down into nothing. The uses for this material are limitless. 75eb for a 6 ounce can, available in aerosol, or liquid form.



DYNALAR VEHICLE DISRUPTOR 2000eb
 This odd looking creation fires a magnet piton, which trails a pair of thin but sturdy wires back to the disruptor (the piton must strike metal for it to affix). When the trigger is pulled a second time, a large surge of electricity travels through the wires to the car, instantly frying any on board computers and electronics of any unshielded vehicle and shutting it down immediately. Each device only stores enough power for one shot, but can be recharged in 4 hours from any electrical socket. The range of the device is only 20 meters, but it has a 50 meter spool of wire, allowing the pursuit vehicle to slow a safe distance before activation. Magnetic pitons and wire spools must be replaced after every shot, and a new set costs 35eb. (If the piton attaches to metal on a persons body, such as armor plating or cybernetics, the damage is 5d6 stun)



ENVIRONMENTAL TECHNOLOGIES ICAD 200eb
 The Integral Chemical Agent Detector (ICAD) is a device used to detect most gases and give the user sufficient warning to take precautionary measures. The ICAD will detect any nerve, regurgitant, blister, or blood agent for 30 meters. The rechargeable battery is good for 4 months continuous use and for an additional 100eb you can have it equipped with an RF transmitter module.



EXTENDABLE MIRROR 5eb
 A small mirror attached to an extendable stick used for safely looking around corners.



ENVIRONMENTAL TECHNOLOGIES HAND HELD ULTRA SNIFFER 4,265eb

This device carefully analyzes the air to identify and locate any preprogrammed scent molecules which might be floating around. This device is even more sensitive than a dog's nose. Of course you have to give it an exact scent to find by inserting a concentrated sample into it, which the device will analyze and use to identify molecules in the air. Very similar to the explosive sniffers at the airport. The device can only store one sample scent at a time, but is very accurate. This means that while it will precisely be able to locate, say money from a sample of the ink used to print it, or a specific drug from a sample, it won't replace the dog for such purposes, because it can only find one specific thing. For example, if you only have a sample of heroin, and you are looking for more, you won't find any other drug but heroin. If you have a sample of gun powder you won't find any C-4 or Semtex. This is rather limiting, but if you know exactly what you are looking for, then this device is a godsend.



ENVIRONMENTAL TECHNOLOGIES POLICE GAS MASK: 240eb

Acts as both a gas mask and a filter, with a 30 minute air supply. It also acts as facial armor (SP10) and features Low Light, Anti Dazzle, Times Square, and Thermograph visual options. Generally available only to police.



HAUER DETENTION COLLAR 150eb

This is an explosive collar used by U.S. Marshall's, bounty hunters, and transfer guards to keep prisoners from escaping. The guard keeps a transmitter on his person (usually implanted) which sends a signal 100 meters away. Once activated, the collar will detonate if it moves out of the signals range. The collar is packed with C-4, and will literally blow the head off of anyone who moves out of range while wearing them. Once activated it can only be deactivated by a special device, usually kept

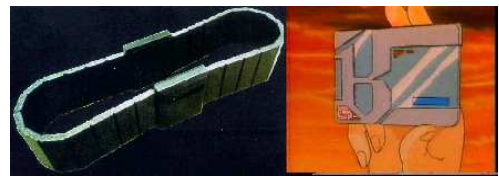

HAUER INDUSTRIAL RESTRAINT BELT 240eb

This restraint belt is pulled over the prisoners shoulders and down to the waist with the arms inside. It is self tightening, so the harder they try and escape the tighter the belt gets. This restraint is so strong that even a standard full conversion cannot break it. The belt is cardlocked to make it even harder to escape. (a Strength Feat roll of 30+ is required to break free.)

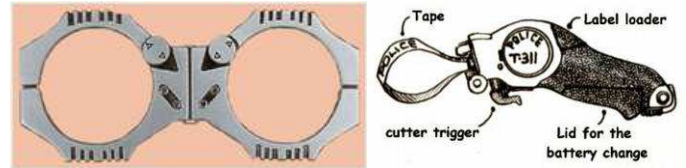

HAUER POLICE ISSUE HANDCUFFS:

Every officer is given 4 pairs of placuffs (which are thinner than regular handcuffs but twice as strong), 2 pair of Ion Cuffs (although most officers don't carry them or leave them in the car), and 10 stripwire binders. (See Protect and Serve for more detail)



HILLARD DIGITAL BINOCULARS 650EB -

These amazing and durable binoculars use a high-powered camera to view the object which is displayed on a video screen in the eye piece. Image enhancement, low light, IR, and teleoptics, as well as a 200 shot digital camera and laser rangefinder/target system are all built in. In event the electronics fail the device may used as normal binoculars.

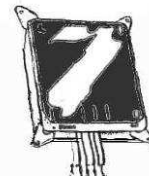

KILMER ADVANCED AUTOMATIC SAFECRACKER 378,950eb

This device is roughly the size of a VHS cassette albeit somewhat thicker. There is a large hole on the back of the device and a small display screen on the front. To use the device you place it over the combination knob, the hole contracts and begins spinning the knob until the sensors detect a change in sound or pressure. When the lock has been successfully cracked the combination will appear on the display screen. The device can store up to ten combinations and requires no skill whatsoever to use. Cracking a safe with this device takes from 30 seconds to ten minutes. Runs off either a rechargeable battery pack (2 hours) or from a wall outlet.



KOBAYASHI SPEECH JAMMER 680eb
 Effective up to 100meters away, this device uses focused sound, shooting a speakers own voice back to him at a delay of a few hundred milliseconds... this creates a disorienting effect in the target, and his words will become complete gibberish, often mimicking the slurred and disoriented speech of someone suffering a stroke. A person who knows what is happening can make a resist torture/drug check at -3 to overcome the device, however someone who doesn't know what is happening will quickly become frustrated at the gibberish they are speaking, unable to determine why or how to overcome it. For the device to work, it must be pointed at the speakers head, and remain there (handgun skill check, base 15, with modifiers depending on how animated the speaker is or becomes). A flip up dot sight in a wide frame helps with this.

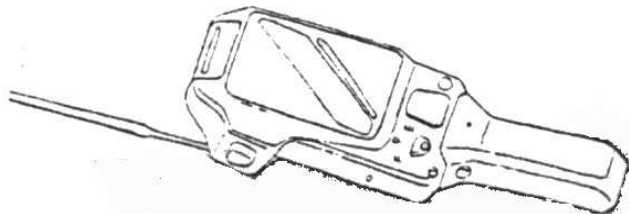

LAZENBY HAND HELD ULTRASOUND DEVICE 4125eb
 Roughly the size of a pack of cigarettes this device uses ultrasound to peek into safes, trunks, etc... The entire front of the device is a monitor which displays an outline of the contents inside the object being scanned. This item is indispensable to thieves and E.O.D. experts. The rechargeable battery pack (about the same size) lasts for 2 hours of continuous use.

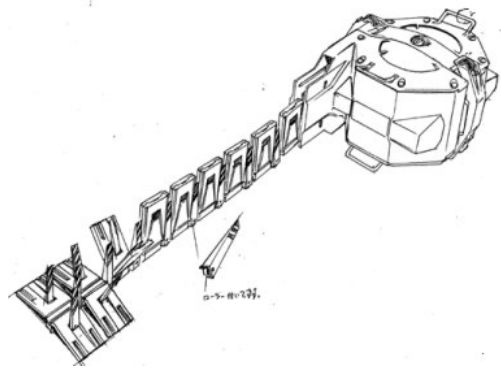

MARS INC. EXPLOSIVE ROAD BARRIER 565eb
 This device is stored in a large case which holds 20 meters of a retracting chain of folding panels. When strung across a road and unfolded, these panels have for lack of a better term, spikes, which fold upwards. These spikes act as a trigger, detonating the panel the trigger is attached too (except for any within 3 feet of the case) whenever a car hits them. The resulting explosion will blow out the front tires of the car, as well as significantly damaging the underbelly. (damage per panel is 2d10 with a 1 foot radius) Any unexploded portions of the panel chain can be reused and restored within the case.



MILITECH HAZ-BOT 7,865eb
 This small remote operated robot is about the size of a large microwave oven. It is used by police, military and private security to remove bombs and hazardous material (maximum load 80lbs storage dimensions 10x15x15inches, armored to SP:30) from sites to a safe area for diffusal/disposal to prevent structural damage or contamination without putting officers at risk.



MILITECH MILITARY BINOCULARS 870eb
 The most powerful binoculars available, with built in range finder, Low Light, image enhancement, thermograph, and attachable laser target acquire system.

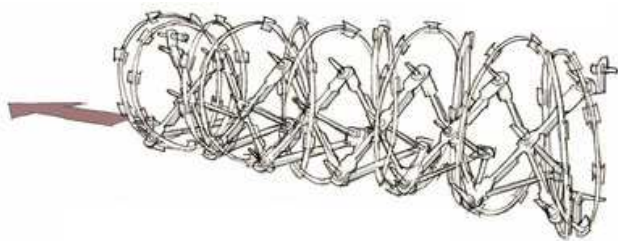

MILITECH RAZOR-WIRE QUICK BARRIER 500eb
 Coiled razor-wire with an expanding/retracing frame for quick but very effective barriers. When drawn out, the razor wire barrier is roughly 4 feet tall and can stretch out to about 20 meters. When retracted the barrier fits into a large hard plastic shell, together weighing about 50 lbs... for easy and safe transport.

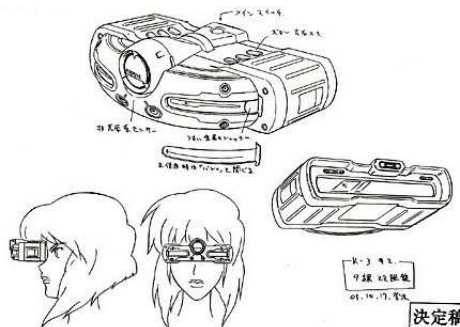

MITSUBISHI ECHO LOCATION GOGGLES 675eb
 These goggles turn high power echo location emissions into a green monochrome image. Other than the view screen, this device emits no light whatsoever, giving the user a distinct advantage in pitch darkness. Because it uses echo location it is also not fooled by thermal dampers or other such measures.

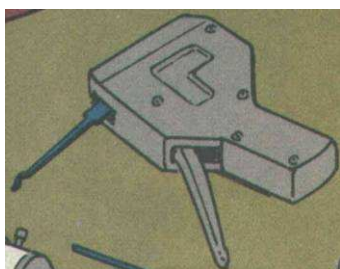

MOORE LOCK PICK GUN 125eb
 A mechanical lock pick the assorted picks are stored in the handle of the device and are color coded for quick selection.



NOMAD RADIO WAVE INTERCEPTOR/JAMMER 85eb
 (From Nomad Market)
 This small device can be used to intercept any radio signal being broadcast, whether it is encrypted or not. Additionally, if within 200 meters of any radio smaller than a backpack, it can jam completely a radio merely by being pointed at it and depressing the green button on the right side.



NIKON SURVEILLANCE DATACAMERA 640EB
 Able to record still frame, video, and audio in a simultaneous wide spectrum array including standard, Low-Light, Thermograph, IR, and Ultraviolet. Is also equipped with both directional and laser mics capable of standard and subsonic recording. The camera can store up to 800,000 images, or 6 hours of video before the data storage unit must be replaced.



NIKON A/V RECORDER SHADES 4800eb
 These somewhat heavy smartshades are designed for war correspondents, extreme sports videographers, and independent medias. They are equipped with audio and video recorders with 2 hours onboard storage, plus a transmitter so they can either film live, or send the data to a backup storage unit. In addition they can have up to 8 cyberoptic options. With a smartlin, the videos can edit their recordings on the go.



NIKON MINIATURE VIDEO RECORDER/TRANSMITTER 300eb
 This is the civilian version of the U.S. military's helmet cams (See U.S. Military Standard Issue, part of Conflict: the African Sourcebook). It is a little more aesthetically pleasing, but is in all other respects identical. 2 hours recording time. It is meant to be attached to a helmet or armor, allowing troop movements and actions to be recorded and coordinated from a central location. Unlike the military version which is fixed to the helmet, this version uses clamp on mountings, allowing it to be removed for hand held operation.



RAVEN MICROCYB FORENSIC DATAGLOVE 435eb
 Used in conjunction with the Advanced Forensic Data Unit these gloves have sensors built into the finger tips, including chemical analysis, ultra-sound, x-ray, and temperature gauge. They also contain an extending 12 inch probe needle, for determining core body temperature. Together, the three forensic units are capable of gathering enough information to create a virtual representation of the crime scene down to the most minute detail, as well as giving investigators on site information unrivaled in history.



RAVEN ADVANCED FORENSIC DATA UNIT 3820eb
 The Forensic Recorder is usually worn by one operative or the forensic team whose sole job is to record the scene. These Units are worn by the rest of the forensic team and allow the team to provide more advanced and focused information. Where the data recorder just stores video and audio information, these smartlinked video recorder headsets allow the ballistics investigator to mark projectile hits and determine trajectory and most likely points of origin. Special filters unique to these headsets, allow the investigator to see biological residue, such as blood and other body fluids, without the use of luminal or special lights. A small laser allows instant readings for surface temperature, distance, and when used with the ballistic digital markers can track distance between two markers. The unit is also equipped with Low Light, Infra Red, Ultra-violet, Thermograph, image enhancement, tele-optics, micro-optics, audio recorder, audio enhancement, and a flashlight. These headsets are worn with the Forensic recorder backpack, but have a built in hard drive with enough memory to cover most small crime scenes.



RAVEN MICROCYBERNETICS FORENSIC RECORDER 15,650EB

One of the greatest law enforcement tools available to the NCPD is the Virtual Crime scene. By use of this device, which consists of a helmet with drop down video monitor display, a powerful back pack processor with data uploader and wireless modem, and a video recording gauntlet, a forensic investigator is able to recreate a virtual crime scene down to the last detail. First the Forensic recorder goes in and records the scene, every inch, from as many different angles as necessary to capture the scene as completely as possible. Including scanning inside drawers, compartments, holes, scanning around bodies and shell casings, and any other even slightly relevant POV. This information is uploaded to the Central Processor at Forensics headquarters and creates the base Virtual Crime Scene. Then every image, both video and still, captured before, during, and after, from any source, is added in to the database. Usually these extra images come from Officer Gun Cams and security videos, but occasionally from cyber eyes or what not. Anyway, these are time stamped and uploaded into the VCS compilation as well, and when all is said and done, in a matter of about 4 hours per 50ft sq room you have a VCS representation. The perfect 3 dimensional VCS representation will allow investigating officers and juries to full explore the Crime scene as if they were actually there through interface. In some cases, if there is enough photographic evidence (and even audio in some instances) an investigator can explore the crime scene in an as it happened manner. Going from the beginning of the crime to the end, pausing and examining even the most minor details, slow motion, fast forward, etc. Any events the police don't have photographic evidence of will often be "best guessed" by the computer, and filled in via the most logical turn of events.



ROTHCO PORTABLE POLYGRAPH UNIT 535eb
 This hand held device is perfect for interrogations, although it will not work on someone with an implanted heart or blood flow regulator, and some heart conditions. (It determines whether a person is lying by their blood pressure.) (Fooling the machine requires a Very Difficult perform role.)



SECSYSTEMS CAMERABALL 350eb
 Need to know the layout of a room in a hurry, throw one of these puppies in there. Once activated the camera begins taking high speed shots which it transmits to a handheld monitor. When the ball stops moving it immediately rights itself and is controllable by remote, allowing it to pivot and rotate for better angles. SWAT teams often toss these in at the same time they throw in tear gas canisters, the distraction allows for better chances to get the necessary images. The entire ball is coated in a thin but pliable film, which both protects the lens, and allows for a slight bounce.



SECSYSTEMS DETECTION UNIT 680eb
 Consisting of a tiny fiber optic camera and microphone, this device is slid under doors and through cracks etc... to give the user a clear picture of the situation before he enters a room. This is a smaller version of the Secsystems Vidsnake.

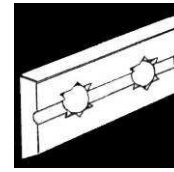

SECSYSTEMS POLICE O.I.D. BUTTON 80eb
 The OID (officer in distress) button is a relatively simple device, it sends a message to the nearest precinct asking for backup, the number of times the device is tapped determines the level of threat. 4 indicates maximum threat. Generally worn on the collar, about an inch long, half an inch wide, and 3 centimeters thick. Generally available only to police.

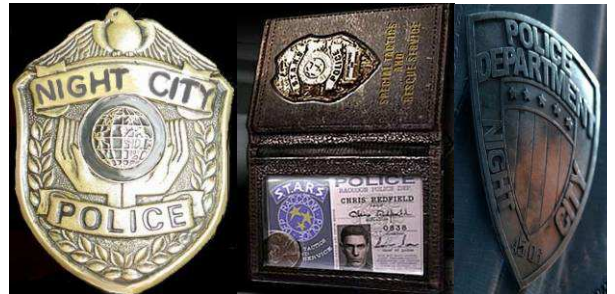

SECSYSTEMS POLICE BADGE 75eb
 The very first piece of equipment a Night City police officer will receive. Today even the badge is improved, it acts as a "cookie cutter" (SOF 1) recognition badge, and works with the devices in police firearms to ensure that one officer cannot shoot another. It also acts as a homing beacon. Both features are controlled from the home precinct and can be shut off by remote. Included with this is the police ID. Generally available only to police.

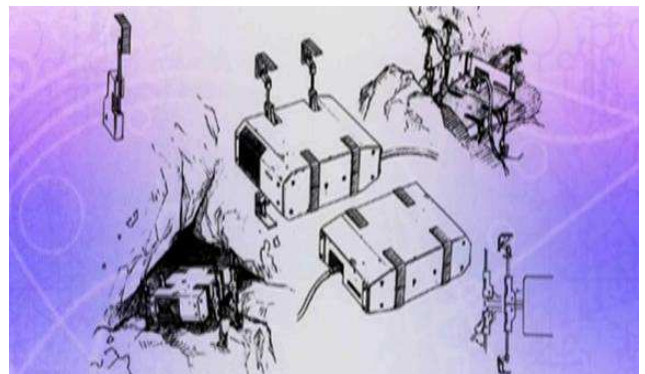

SECSYSTEMS SEISMIC SENSOR 320eb
 This device can sense heavy vibration in the ground up to 20 meters. Bury the device just under the ground, with only the antennae protruding. For best results place next to a road. The device won't usually pick up foot traffic (unless its in large numbers) but it will detect vehicle movements. So if you live on a private road, or have an extended drive, this device can give you warning of incoming visitors.



SECSYSTEMS SONAR BALL 475eb

This bouncing ball, once activated, can be placed, or for better results thrown, into a room. Somar Emitters sends out sonic pulses, which rebound off all the surfaces in the room back to the back to the ball. These signals transmit to a receiver (which plugs into any computer, laptop, or cyberdeck) instantly creating a 3-D image of the room, and as long as the Sonic Ball transmits, the image is live, so any movement or changes to the room is instantly replicated. Created for hostage situations, this actually provides a far more accurate view of the room than the Camera ball, though they are often used in conjunction with each other. Like the camera ball, these devices are coated in a rubbery membrane, though the Sonar Ball's membrane is thicker, allowing for much more bounce.

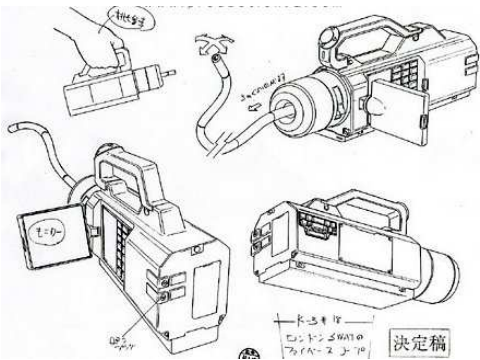

SECSYSTEMS VIDSNAKE 11,750eb

This surveillance camera features a 50 spool. Because the sections of the cable are adjustable, it allows some small measure of steering, allowing the user to maneuver the camera with expert precision. The video has standard, IR, Thermograph, and Low-light capabilities.

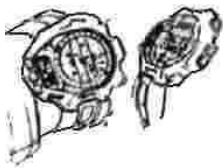

SEIKO COVERT WATCH 300 - 2500eb

A fully functioning watch with a few minor additions. Around the face of the watch is a hidden monowire garrote, it is attached directly to the watch and the other end to the false setting which conceals it. For men size watches you may also choose between a ten shot camera, a Geiger counter, or a tracking device.....range 100 meters. Available in a wide variety of styles for both men and women.

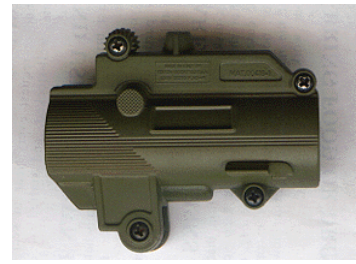

SNEAKERTECH POWER STROBE 95eb

This device is hooked into the power supply of a building, and creates a strobe effect for the power flowing into the building, basically turning it on and off repeatedly. It can be set from a true strobe effect, activating every second, or can be set for up to 2 minutes on - two minutes off. This device can only be activated for up to ten minutes before it burns out completely, and once used it can never be used again. Perfect for creating a diversion, or just confusing your enemies long enough to get what you came for.

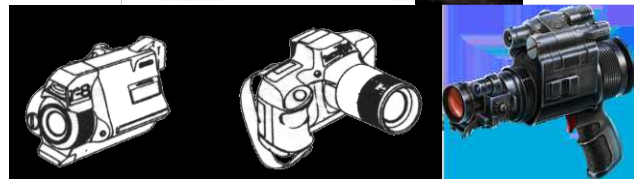
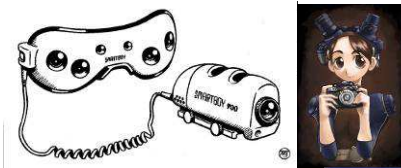

VIDEO AND PHOTOGRAPHIC EQUIPMENT (price varies)

Autumn Blade spends a lot of time and money on surveillance, and as such understands that many of its clients face the same problems. For this reason Autumn Blade stocks a wide variety of video and photographic equipment and accessories. We also employ qualified technicians and advisors to help you get the most for your money and needs.



ZETATECH MICRO-SECURITY SYSTEMS 40eb

Zetatech Micro-Security units are small, battery powered security lasers, cameras, microphones, and other detectors. They all operate off the same 8 hour battery base with wireless transmitter, and can be placed nearly anywhere. Perfect to provide an early warning perimeter system in hasty encampments, or to provide other quick temporary security solutions. Each unit is small enough to fit into a pocket, and costs 40eb apiece. Available units are Cameras, laser tripwires, microphones, and thermal cameras.

WEAPON ACCESSORIES



AMERITECH RIFLE AND SHOTGUN SURVIVAL ACCESSORIES



Side saddles for quick reloading (6 extra shells on the receiver mounts 6eb, 5 on the buttstock mounts in 10 or 12 guage 5eb), x2 for 20 gauge or for rifle ammunition)



A 5" bayonet knife mounted to the barrel with cap (1d6 damage) 40eb



A tactical flashlight/compass combo mounted to the barrel 20eb



A hollow buttstock containing an emergency survival kit with baking pan, trash bag, fishing kit, 2 non-lubricated condoms, water purification tabs, reflective survival blanket, a small first-aid kit, Carmex lip balm, a whistle, small Bic lighter and snare wire. 65eb



A hollow vertical grip containing a small fire-starting kit (matches, striker, steel wool, WetFire brand fire starting material). 35eb



A hollow pistol grip containing a multi-tool. 40eb



A saw that can be attached between the buttstock and gun handle for cutting down wood



Padded extra ammo storage sling, can hold either 15 10 or 12 guage shells, 30 rifle or 20guage shells, and the pad has a zippered pocket for storing a folded map, cash, or notepad.



DESPERADO SLEEVE RIG 65eb

The best way to keep an ace up your sleeve, these rigs can accommodate whatever small object you need, cell phone, knife, small handgun. Buy them in pairs for twice the fun. Puts your chosen tool in your hand at the flick of a wrist, or if you are so inclined, by pressing your wrist backwards into a pressure switch. Limited only by what can easily slide in and out of your sleeve.



GE MILITARY LASER TARGET DESIGNATOR 425eb

With a range of 300 meters, this device is used by special forces to paint a target for surgical precision missile strikes.

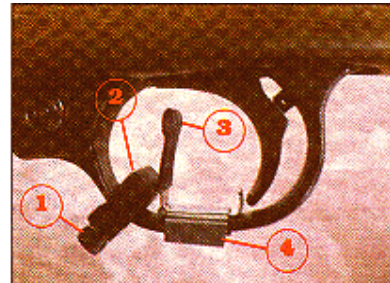

HELLFIRE WEAPON SUPPLEMENT 150eb

This small plastic device is fitted behind the trigger of your firearm, it uses a spring to increase the ROF of any semiautomatic weapon by bouncing the trigger back and forth off your finger. When fitted properly it doubles the ROF of any semi-automatic weapon (x2 number of available quick actions).

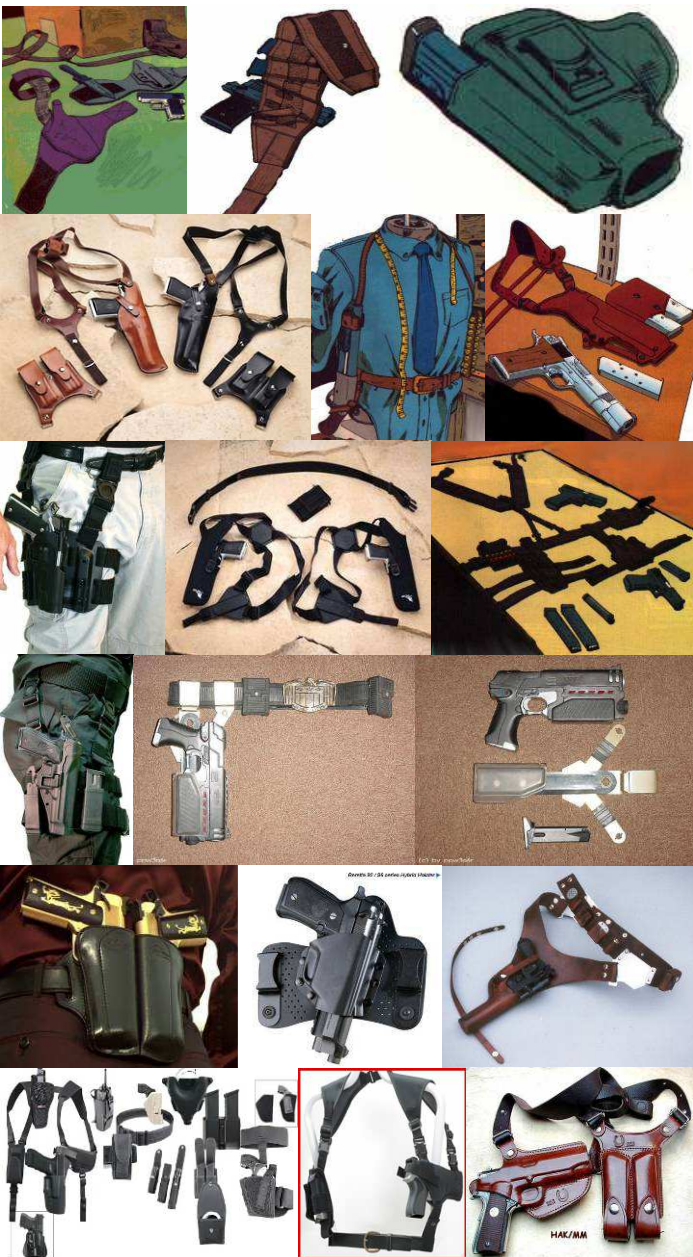

HOLSTERS AND TACTICAL GEAR price varies
 A complete assortment of holsters, sheaths, webgear, slings etc.... Customization upon request.



LASER SIGHTS price varies
 Autumn Blade stocks a wide variety of laser sights. However the best, most efficient and snag free sights, have the electronic switch custom wired internally to a small pad on the trigger.

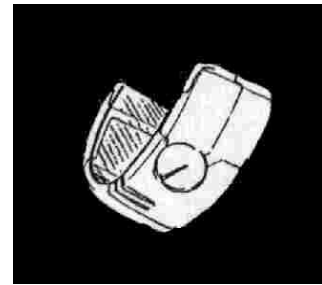

MICROSHOCK STASIS BRACELET SMARTLINK 225eb
 This bracelet, which at a casual glance will merely seem cosmetic, and is suitable for both men and women, hides an ulterior purpose. It is an alternative to your smartgun link, and every time you transmit the impulse to fire your weapon, the bracelet gives off a series of painless (although a tingle is felt) shocks to the arm, locking it in place as you fire. By doing so it reduces recoil and lets you maintain a locked aim on the target, increasing your accuracy by +2. (For surgery, HL, and use, treat as a smartgun link.) (Note: after using this device, the arm will feel tingly, and after extended use the arm will feel numb and sensitive.)

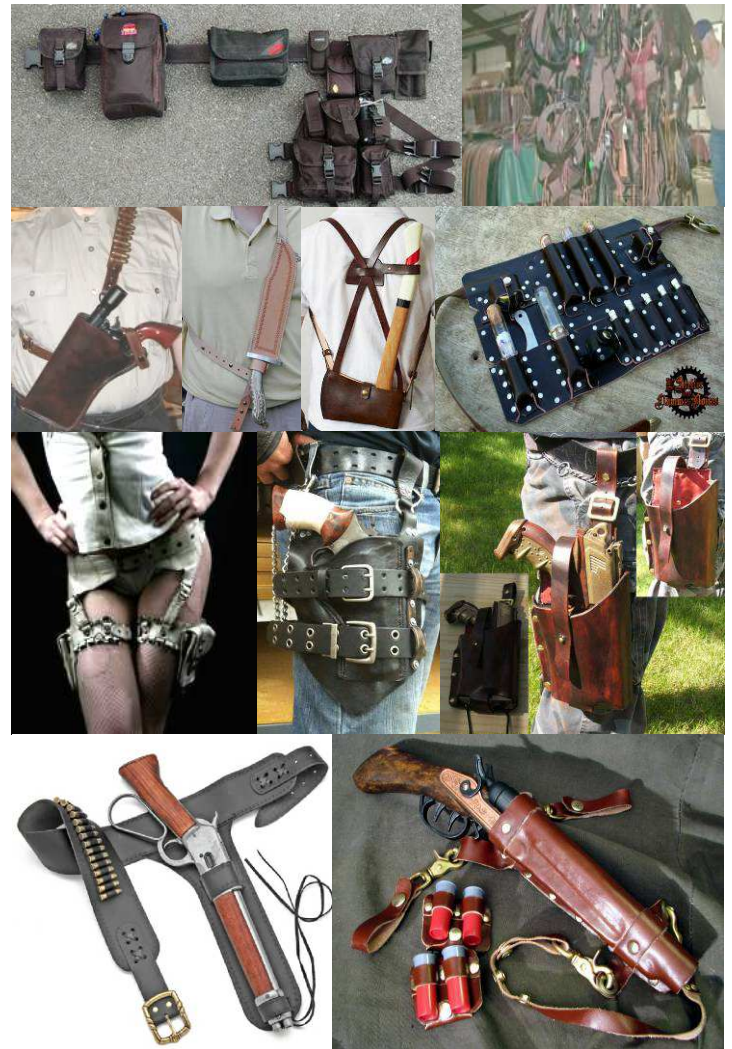

NOMAD GUNBELTS Price varies from 20-200eb
 Get a rig for any weapon or item, to hold on any part of your body. Need it to do more, just ask. Can't find exactly what you are looking for, one of the many leather crafters in the Market will make whatever you want, exactly to your specifications.

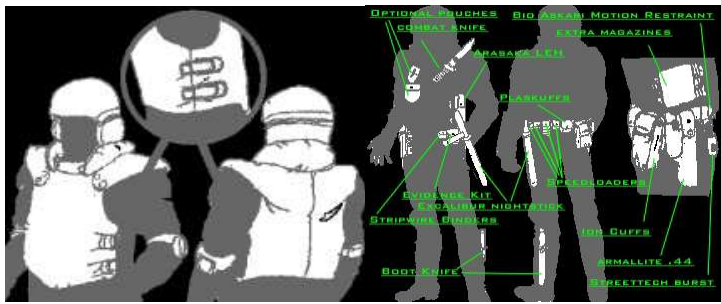

POLICE ISSUE GUN BELT AND SHOULDER HOLSTER:

Standard issue, a gun belt with pouches for the equipment and a holster for the Armalite .44, and a shoulder holster that attaches to the left side buckles of the vest for the Arasaka LEH. (For left handed officers everything can be reversed.)

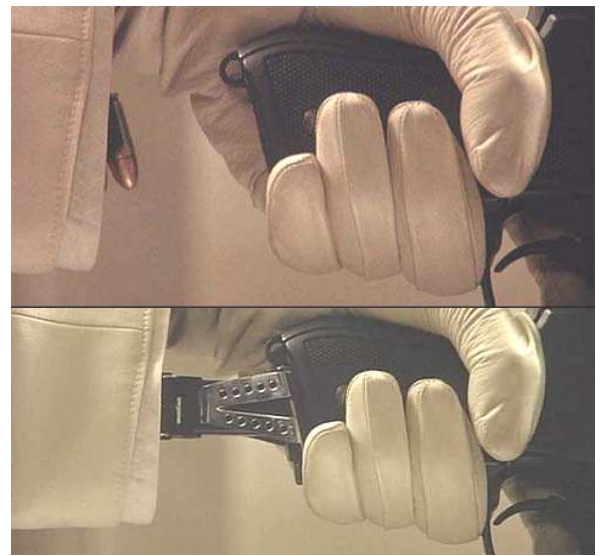

WRIST MOUNTED MAGAZINE RELOADER 60eb

These easily concealable devices are worn like a gauntlet on your wrist. They are spring loaded, and when activated push a spare magazine out just far enough to allow you to replace the magazine of your handgun one handed. When worn under a loose sleeve, they require a 20 on an awareness notice roll to spot



SCOPES 20-250eb

Autumn Blade offers a wide selection of scopes and other sighting devices for all varieties of firearms. Whether it be a simple DOT sight, a plain scope, or a scope with optic options we have the perfect compliment to your needs and shooting styles.



SILENCERS 50-300eb

Silencers and suppressors to fit just about any firearm.

CLOTHING

ADAM'S

CASUAL MEN'S WEAR



Aleksi Trenchcoat
120eb



BRERETON
Muscle shirt 20eb
Jeans 40eb
Boots 80eb
Leather wristbands
20eb apiece
Belt 40eb



D20
Sport coat 80eb
Shirt 50eb
Pants 45eb

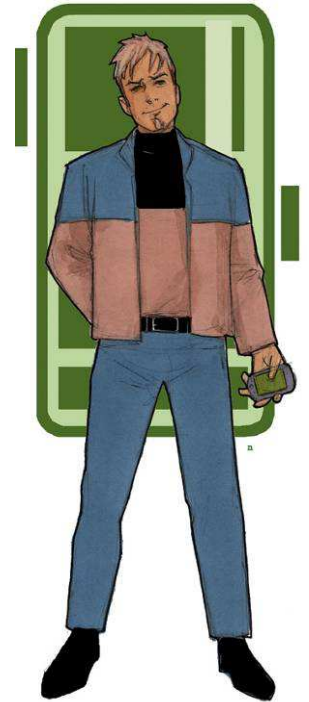

D20
Pants 40eb
Shirt 25eb
Jacket 60eb
belt 15eb
shoes 60eb



Borgia
Vest (sp:8) 160eb
Shirt 25eb
Belt 15eb
Pants 45eb



D20
Shirt 35eb
Pants 50eb
Shoes 65eb



D20
Jacket 80eb
Shirt 15eb
Jeans 45eb
belt 15eb
shades 50eb
shoes 60eb



Egostates
Trench (SP:10) 200eb
Shirt (sp:4) 130eb
Pants (SP:4) 160eb



HANES
Shirt 10eb
bandana 5eb



Hyung-Tae Kim
Jacket 120eb
Shirt 50eb
Pants 75eb
Shoes 100eb



Hyung-Tae Kim
Shirt 80eb
Pants 75eb
Gloves 40eb
Shoes 140eb



JENSEN
Overcoat (SP:12) 650eb
Shades (option) 130eb
Shirt 20eb
BDU Pants 50eb
Tactical Gear 50eb



Hyung-Tae Kim
Shirt 50eb
Pants 65eb
watch 40eb
Shades 35eb
Shoes 125eb



Hyung-Tae Kim
Jacket (sp:6) 200eb
shirt 40eb
pants 65eb



Impulse
Jersey 25eb
Pants 40eb
Nike Shoes 140eb



Junkie
Jacket 240eb
Jeans 60eb
Shirt 15eb



JUNKIE
Jacket 120eb
T-Shirt -15eb
Jeans 40eb



Max
Jacket 120eb
Pants 60eb
Shoes 140eb



Owens
Jacket (SP:10) 455eb



ROWF
Hat 30eb
Shirt 45eb
Jacket (SP:10) 150EB



Lores
Jacket 50eb
shirt 15eb
jeans 40eb



SIN
Shirt 40eb
Pants 45eb



SOLITARIO
Leather Jacket 250eb
Gloves 25eb
Jeans 40eb
Belt 20eb
Armored Smartgoggles
(SP:10 4 options) 530eb

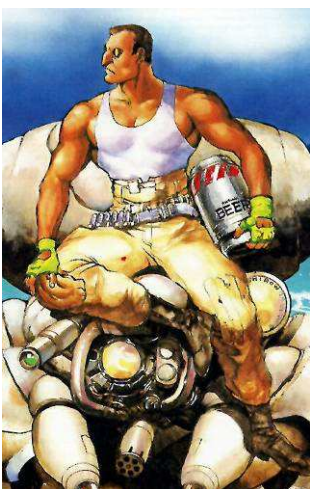

Masamune
Shirt 10eb
Pants 50eb
Belt 30eb
Boots 75eb



NITROPLUS
Trench coat (SP:14)
500EB
Pants 60eb
Shirt 20eb
Shoes 80eb



RESIDENT
Trench coat (SP:12)
1600eb
Boots 130eb



SOLITARIO
Leather Jacket 200eb



THD
 Hat 30eb
 Shirt 15eb
 Shorts 20eb
 Shoes 65eb
 Goggles 20eb



THD
 Jacket 50eb
 Shorts 30eb
 Shoes 85eb



Walkies
 Sleeveless shirt 10eb
 Shorts 20eb
 Shoes 40eb



Wegs
 Poncho 35eb
 pants 40eb



WANDERER
 Riding Goggles 203b
 Leather Vest 80eb
 Jeans 45eb
 Chaps (SP:4) 95eb
 Boots 120eb
 Gloves 30eb



XTRONIC
 Shades 40eb
 Leather Jacket 130eb
 shirt 10eb



THD
 Hat 18eb
 Jeans 55eb
 Shoes 70eb
 Belt 25eb
 Boxers 20eb

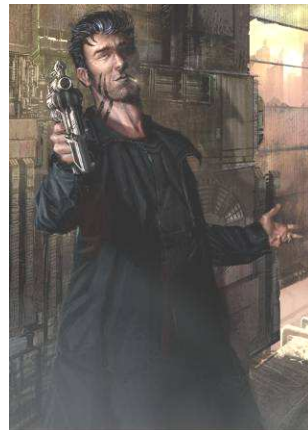

URBANTECH
 TRENCHCOAT 140EB
 PANTS 40EB
 SHORT 35EB



URBANTECH
 T-SHIRT 40eb

GIANCARLOS

FORMALWEAR FOR MEN

Once rumored to have mafia ties, Giancarlo was forced to agree to a total neutrality before being allowed to set up shop in Nakajimo center. It does however still use that image as advertising. Not that it needs to, Giancarlo is known for having the finest selection of men's formal in Night City. Top designers from Europe and Asia, as well as suits custom made and fitted on demand.



BEBOP
Suit 620eb
shirt 110eb
Tie 50eb



D20
Trench 370eb
Suit 730eb
Shirt 160eb
watch 800eb
shoes 275eb



D20
Overcoat (SP:8) 540eb
Suit 460eb
Tie 65eb
Shoes 210eb
Shades 150eb



D20
Suit 350eb
Turtleneck 150eb
Shoes 120eb



BORGIA
Suit 460eb
Tie 40eb
belt 20eb
shirt 125eb



D20
Suit 1895eb
Smartglasses (2
cyberoptions) 960eb



D20
Suit 595 eb
Shirt 150eb
Tie 89eb
Shoes 200eb
Briefcase (SP: 20)
515eb



D20
Overcoat 985eb
Suit 840eb
shoes 250eb
Shirt 200eb



DRACO
Red suit 650eb
Orange suit 475rb



Equilibrium
Suit (SP:8) 590eb



Equilibrium
Coat (SP:10) 305eb



Equilibrium
Suit 620eb



GIANCARLO
Suit 2570eb
Tie 165eb
Shirt 145eb
Glasses 260eb



Hyung-Tae Kim
Turban 180eb
Coat 350eb
Scarf 60eb



Hyung-Tae Kim
Jacket 1480eb
Vest 885eb
Pants 600eb
shirt 550eb
Cane 645eb
Scrollcase 50eb



Hyung-Tae Kim
Jacket 1600eb
Pants 620eb
Ascot 50eb



Hyung-Tae Kim
Overcoat 1600eb
Pants 200eb
shirt 150eb
Tie pin 650eb
Riding crop 140eb
Shoes 210eb



Hyung-Tae Kim
Overcoat (SP:10)
1700eb
Pants 185eb
shirt 125eb
shoes 220eb



Hyung-Tae Kim
Coat 915eb
gloves 50eb
pants 185eb
Ascot 45eb



Hyung-Tae Kim
Hat 100eb
Opera Cloak (SP:12)
1900eb
Vest (SP:6) 310eb
Shirt 185eb
pants 220eb
Ascot 35eb



Hyung-Tae Kim
Priests Robe (SP:10)
710EB



NEOWEAR
Overcoat (SP:8) 670eb
Suit 560eb
Boots 245eb
Gargoyle Shades 220eb



Nitroplus
Suit 370eb
Shirt 135eb
Tie 145eb



Scallion
Mask 200eb
Shades 120eb
Coat 200eb
Shirt 50eb
Pants 95eb
tie 30eb
gloves 140eb
cane 120eb
shoes 300eb



Matrix
Trench 510eb
Suit 500eb
shirt 75eb
tie 50eb
Shades 120eb



Nitroplus
Chinawear Robe
(SP:10) 540eb



Nitroplus
Jacket (SP:8) 1520eb
Shirt 140eb
Pants 160eb
Boots 290eb



17 SAKU
RYU'S FORM
Silk Jacket: 310eb
Silk Shirt: 80eb
Silk Pants: 120eb
Sharkskin Boots: 500eb



Scourge
Hat 120eb
Mask 50eb
Coat (SP:10) 1420eb
pants 300eb
shoes 600eb



Matrix
Sharkskin coat 2460eb
Vest 300eb
Pants 320eb
Shirt 140eb
Tie 80eb



Smith and Sons
Black Suit 500eb
Tie 40eb
shirt 35eb
Oakley shades 175eb

CRYSTALS

CASUAL WEAR

Everyday fashion for women and girls.
Brand name and designer fashions.



AHN
Gloves 20EB
Leather top 60eb
Jeans 75eb
belt 15eb



AKIHABARA
Coat 85eb
Blouse 45eb
Pants 85eb



ALICE
Top 35eb
Jeans 85eb



ANNA F
Jacket 80eb
shirt 65eb



AIR
Top 30eb
Shorts 25eb
Belt 40eb
Visor 10eb
Gloves 15eb



ALEKSI
Top 75eb
Pants 50eb



ANGELHEART
Blouse 55eb
Skirt 60eb



ANNA F
Leather top 120eb
Leather Pants 145eb
Shoes 130eb
belt 20eb
bracelets 10eb



ANGELHEART
Jacket 55eb
Blouse 40eb
Tie 10eb
Boots 80eb
Skirt 35eb
Panties 10eb
Hose 25eb



ANNA F
JACKET 105eb
shirt 85eb



ANNA F
 TOP 35eb
 shorts 30eb
 boots 140eb
 gloves 40eb



APHRODITE
 Leather Pants 80eb
 Leather Jacket 115eb
 Boots (SP:10) 240eb



ASPEN
 Top 40eb
 Skirt 65eb
 Wrap 60eb
 Shoes 120eb



BLADE STUDIOS
 Shirt 30eb
 Skirt 40eb



ARELLANO
 Tennis Top 40eb
 Skirt 35eb
 Shoes 55eb
 Panties 20eb



BEBOP FASHIONS
 Jacket 50eb
 Shirt 40eb
 Pants 50eb
 hat 80eb
 belt 35eb



BOKUMAN
 Top 40eb
 Pats 60eb
 Shoes 20eb



Anna F
 Dress 160eb
 Shoes 40eb



ARTAD
 Jacket 100eb
 Shirt 30eb
 Pants 60eb



BIONIC
 Datafilm (sp:4) 450eb



BORGIA
 JACKET 45eb
 Blouse 55eb
 Skirt 40eb
 Leg Warmers 45eb
 Boots 130eb



BOUNCER
Slick Pancho 65eb
Waterproof Boots 85eb



CYZRAUL
Body Sui 60eb



D20
Shirt 40EB
Jeans 85eb
Panties 30eb
Shoes 65eb



D20
Shirt 70eb
Gloves 105eb
Shorts 80eb
Boots 459eb



D20
Hat 50eb
Coat 200eb
blouse 40eb
Pants 60eb
Shoes 135eb
Purse 60eb



BRADSTREET
Leather bra 100eb
Vest 40eb
Leather Chaps 150eb
Jeans 75eb



CROFT
Shirt 20eb
Cutoff Shorts 65eb
Boots 80eb



D20
T-shirt 20eb
Skirt 45eb
Belt 25eb
Boots 92eb



D20
Dress 105eb
shoes 20eb
Shirt 30eb
Skirt 40eb
boots 75eb



D20
 Striped Top 20eb
 Striped panties 15eb
 Pants 50eb
 Black Shoes 60eb
 Belt 40eb
 Purse 52eb
 Backpack 60eb
 White Shirt 35eb
 Pink Tie 15eb
 Skirt 40eb
 Spiked Belt 65eb
 Orange Shoes 65eb
 Socks 10eb



D20
 Blouse 40eb
 Skirt 30eb
 Shoes 140eb



DANGER GIRL
 Pants 50eb
 Shirt 30eb
 Belt 25eb



DOMINO
 BLOUSE 65EB
 Bra 45eb
 Jeans 80eb

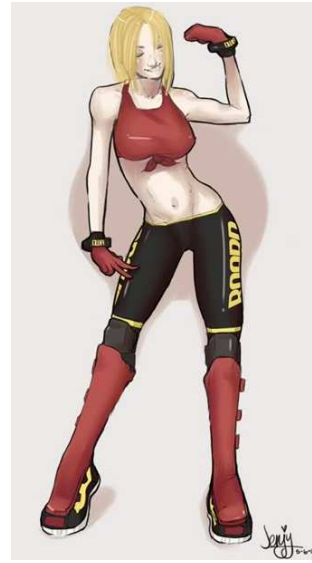

DEVILITA
 Top 25eb
 Cycle pants 50eb
 Gloves 20eb
 Motorcycle Boots
 (SP:10) 85eb

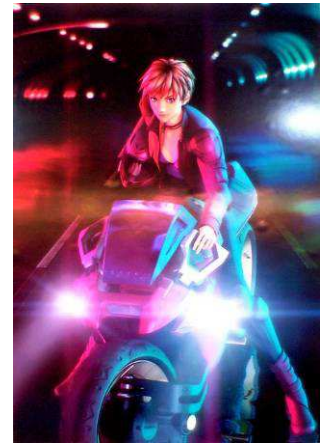

DUENA
 Leather Jacket 165eb
 Riding Pants 85eb
 Cycle Boots 200eb



D20
 Jacket 65eb
 Shirt 20eb
 Pants 50eb
 Shoes 80eb



D20
 SHIRT 45eb
 Bra 85eb
 Skirt 70eb
 Boots 160eb



DYNASTY
 Silk Top 80eb
 Silk Pants 90eb
 Gold Armlet 250eb



ESI
SPORTS BRA 30eb
Skirt 20eb
Pants 45eb
Shoes 70eb



GEZ
Top 30eb
Jeans 80eb
Shoes 65eb



GOGIRL
Skirt 30eb
Blouse 25eb
Purse 15eb
Shoes 50eb



FAYE
VEST 25eb
SUSPENDERS 15eb
SHORTS 30eb
BOOTS 45eb



GILT
blouse 50eb
skirt 40eb
hose 30eb



GOGIRL
Pants 60eb
Shirt 20eb
Shoes 120eb
Gloves 15eb
Bandana 10eb
Peralta Gas Powered
Skateboard (30mph)
350eb



EVA
BERET 20eb
Jacket 75eb
dress 120eb



GALLHOUND
BLOUSE 50eb
Skirt 35eb
Shoes 40eb



GOGIRL
Shorts 50eb
Shirt 30eb
Cap 20eb
Shoes 150eb
Umbrella 20eb
Watch 35eb



EVA
Jacket 65eb
top 20eb
Shorts 35eb
Panties 35eb



GOGIRL
Jacket 135eb
belly shirt 225eb
Pants 85eb
Ski boots 130eb
Go Snowboard 300eb



SYDNEY Alternate Altira T4S 2000

GOGIRL
Jacket 60eb
Shirt 15eb
Pants 50eb
boots 115eb
Gloves 50eb



HIMIKO
TOP 65eb
Skirt 40eb
Gloves 35eb



HYUNG-TAE KIM
Dress 160eb
Gloves 40eb
Legging 60eb



HYUNG-TAE KIM
Jacket 90eb
Pants 150eb
Vest 80eb
gloves 55eb
Boots 125eb



HYUNG-TAE KIM
Sweater 70eb



HYUNG-TAE KIM
Shirt 90eb
Pants 85eb
Shoes 50eb



HYUNG-TAE KIM
Dress 120eb



HYUNG-TAE KIM
Dress 130eb
Opera Cloak 150eb
Hose 40eb
Gloves 90eb



HYUNG-TAE KIM
Shirt 30eb
Shorts 35eb
Gauntlets 40eb



HYUNG-TAE KIM
Sweater 80eb
Skirt 50eb
Shoes 100eb
Gloves 40eb
Purse 200eb



HER
Boa 20eb
Top 20eb
Jeans 75eb
Belt 45eb
Shoes 50eb



HYUNG-TAE KIM
 Blouse 90eb
 Skirt 60eb
 Shoes 75eb
 Sash 60eb
 Head wrap 20eb
 Cane 260eb



HYUNG-TAE KIM Dress
 160eb
 Stockings 75eb
 Shoes 130eb



HYUNG-TAE KIM
 Top 40eb
 Skirt 45eb
 shoes 50eb



INSIDER
OVERCOAT 200EB
 Bodysuit 90eb
 Leather Thigh Boots
 325eb



HYUNG-TAE KIM
 Vest 50eb
 Shirt 40eb
 Shorts 60eb



HYUNG-TAE KIM
 Top 40eb
 shorts 50eb
 dress 150eb
 Tights boots 260eb
 panties 45eb
 Gloves 40eb



INDE
 Jacket 85eb
 blouse 45eb
 Shorts 40eb
 Boots 100eb



INSIDER
 Leather Jacket 200eb
 Skirt 65eb
 Spandex Turtleneck
 70eb
 Hose 30eb



HYUNG-TAE KIM
 Skirt 60eb
 Blouse 40eb



ISHIDA
 Blouse 20eb
 Skirt 35eb



JD
 Skirt 40eb
 Jacket 225eb
 Blouse 15eb
 Shoes 30eb
 Purse 15eb
 Watch 55eb



KUROITA
 Top 35eb
 Jeans 125eb
 Shoes 30eb



LARKABELLA
 Datafilm Bodysuit
 (SP:4 SP:10 shoulder,
 elbow, kneepads)
 800eb
 Leather/Datafilm
 Trench (SP6) 500eb
 Combat Gloves 50eb



LOW
 top 25eb



MAIBLOK
 Hat 30eb
 Jacket 160eb
 shirt 15eb
 jeans 95eb



JD
 Shirt 20eb
 Suspenders 5eb
 Shorts 25eb
 Hat 30eb
 Boots 55eb



LARKABELLA
 Datafilm Bodysuit
 (SP:4) 300eb



LIPPY
 Vinyl Body Suit 350eb

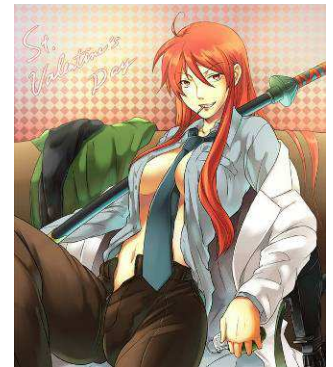

MILCHO
 Jacket 50eb
 Shirt 25eb
 Pants 30eb
 Tie 15eb



KITE
 Sailor suit 70eb
 Panties 30eb



MISHKA
LEATHER TOP 130eb
Leather Pants 160eb
Boots 120eb



NEWSTUFF
Dress 300eb



roplus 2002 Copyright all rights resen
NITROPLUS
Jacket 200eb
Top 95eb



MIYUKI
Skirt 30eb
Blouse 15eb
Shoes 25eb



NGUYEN
Ski Jacket 120EB
Ski Boots 90eb
Panties 30eb



PHAM
Sweater vest 55eb
Tweed skirt 30eb
Shoes 60eb



POOC
Leather Jacket 260eb



Copyright © Stahber
 submitted for critique = CGNetworks.com | CGTalk.com

PRESENT
Top 120EB
pants 145eb
Boots 160eb
Hat 50eb



MOMANUALE
Shirt 60eb
Leather Pants 200eb



©2002 May-Be
NITROPLUS
Coat 250eb
Blouse 80eb
Skirt 75eb

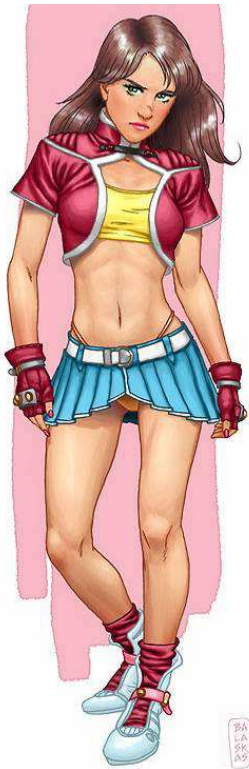

PRYDEWEAR
 Top 60eb
 Skirt 50eb
 Gloves 35eb
 Shoes 40eb



RAVE
 Vinyl Top 60eb
 Leather Pants 150eb
 Boots 200eb



RELAX
 Shirt 20eb
 Shorts 30eb
 Boots 50eb



RESIDENT
 Dress 100eb



RLS
 Chinese Dress 150eb
 hose 35eb



RAVE
 Poncho 90eb
 Scarf 20eb
 Leather Pants 160eb



RAVE
 T-shirt 15eb
 Scarf 20eb



RESIDENT
 Top 25eb
 Skirt 40eb
 Boots 60eb



RYU'S FORM
HARD SHELL VEST
 (SP:10) 300eb
 Gloves 30eb
 Skirt 40eb
 Panties 20eb
 Stockings 30eb
 Boots 60eb



RAVE
 Leather Vest 100eb



RESIDENT
 Top 55eb
 Skirt 40eb
 bracelets 20eb
 Necklace 15eb



RYU'S FORM
 Hat 20eb
 Sailor Jacket 30eb
 Skirt 20eb
 Scarf 15eb
 Kneepads 40eb
 Skates 80eb



RYU'S FORM
 Hat 20eb
 Shirt 15eb
 Pants 25eb
 Chaps 60eb
 Gloves 20eb

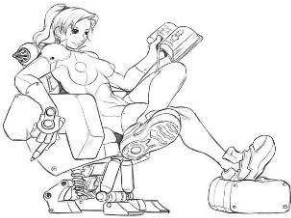

SEABA
 Datafilm Unitard 400eb
 Shoes 60eb



SHIROW STUDIOS
 Blouse 120eb
 Skirt 80EB



SHIROW STUDIOS
 Hat 40eb
 Shirt 20eb
 Shorts 30eb
 Backpack 60eb
 Purse 20eb
 Bracelet 40eb
 Belt 10eb



SHIROW STUDIOS
 Jacket 60eb
 Skirt 50eb
 Shoes 45eb
 Mask 20eb
 Purse 35eb



SHIROW STUDIOS
 Hat 10eb
 Jacket 50eb



SHIROW STUDIOS
 Dress 80eb
 Jacket 60eb
 Purse 25eb



SHIROW STUDIOS
 Business suit 120eb
 Tie 20eb
 Glasses 35eb



SHIROW STUDIOS
 Raincoat 75eb
 Umbrella 35eb
 boots 120eb
 mittens 20eb



SHIROW STUDIOS
 Dress 140eb
 Boots 200eb
 Gloves 35eb



SHIROW STUDIOS
 Sweater 80eb
 Jeans 70eb



SHIROW STUDIOS
 Jacket 200eb
 Riding pants 80eb
 Cap 40eb



Shirow Studios
 Jacket 50eb
 Blouse 30eb
 Pants 45eb
 Shoes 60eb
 Briefcase 130eb



SHIROW STUDIOS
 Leather Dress 210eb
 Eye Patch 40eb
 Boots 250eb
 Panties 20eb



SHIROW STUDIOS
 Blouse 40eb
 Leather Pants 140eb
 Shoulder holster 60eb



SHIROW STUDIOS
 Bandanna And Pin,
 25EB
 Dress 60eb



SHIROW STUDIOS
 Blouse 60eb
 Pants 75eb



SHIROW STUDIOS
 Casual suit 260eb
 boots 160eb



SHIROW STUDIOS
 Blouse 35eb
 Skirt 30eb
 Hat 20eb



SHIROW STUDIOS
 Coat 170eb
 Blouse 50eb
 Skirt 65eb

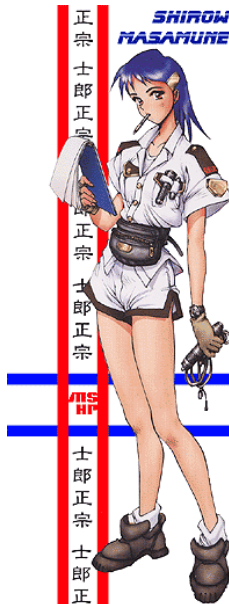

SHIROW STUDIOS
 Blouse 40eb
 Shorts 30eb
 Shoes 60eb
 Waist pack 35eb



SHIROW STUDIOS
 Blouse 60eb
 Bra 45eb
 Pants 75eb



SHIROW STUDIOS
 Hat 60eb
 Jacket 90eb
 Skirt 40eb



SHIROW STUDIOS
 Blouse 30eb
 Med Coat 60eb
 Skirt 60eb
 Panties 30eb
 Shoes 45eb



SHIROW STUDIOS
 Black Leather Jumper
 160eb
 Boots 90eb
 White Leather Jumper
 140eb
 White top 50eb
 Long Gloves 60eb
 short gloves 30eb
 Pirate boots 80eb



SODA
 Shirt 20eb
 Jeans 60eb
 Boots 100eb



SQUID
 Leather Jacket 120eb
 Shirt 15eb
 Vinyl Pants 85eb
 Purse 70eb
 Sunglasses 20eb



STARLIGHT PAGODA
 Jacket 200eb

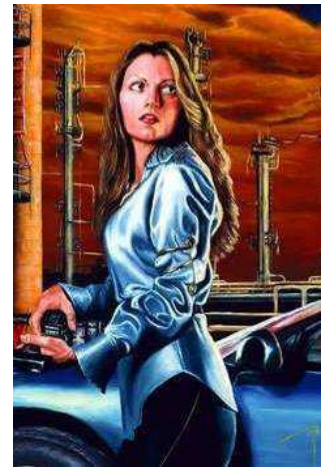

SUZ
 Blouse 300EB
 Pants 150eb



TAZ
 TOP 30EB
 BRA 25EB



TEKKE
 Disco Bikini 50eb
 Chromasilk Pants 75eb
 Chromasilk Gloves
 40eb
 Armbands 20eb each



SHIROW STUDIOS
 Vinyl Bodysuit 200eb
 Hat 50eb
 Boots 90eb



THD
 Shirt 45eb
 Pants 30eb
 Gloves 35eb
 Shoes 40eb
 Belt 75eb
 Choker 50eb
 Socks 10eb



THD
 Shirt 100eb
 Spandex Shorts 40eb
 Boots 120eb



TRINITY
 Alligator Jacket 380eb

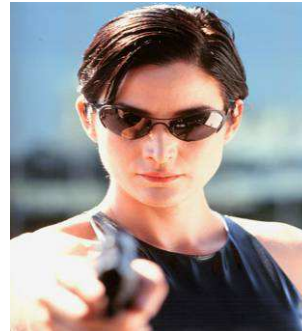

TRINITY
 Leather Shirt 130eb
 Jacket 210eb
 Shades 75eb



WARRENLOU
 Datafil Tank Top 60eb
 Datafilm Pants /boot
 combo 145eb
 Datafilm Sleeves 50eb



THD
 Top 45eb
 Overalls -80eb
 Boots 75eb
 Hat 15eb



TOYUMI
 Shirt 15eb
 Skirt 35eb
 Belt 20eb
 Hose 15eb
 Gloves 20eb
 Backpack 35eb



TRANQUILITY
 Jacket 85eb
 Shirt 40eb
 Pants 60eb
 Shoes 85eb
 Belt 35eb



URBANA
 Leather Jacket 105eb
 Scarf 10eb
 Purse 85eb
 Sweater 40eb
 Skirt 40eb
 Shoes 65eb



WINDRIDER
 Vynil Bodysuit 400eb
 Belt 80eb



WOG
 Blouse 35eb
 Skirt 50eb

HOPES ELEGANCE

Taste, style, class, in short, elegance, Hopes Elegance. Fine women's fashion for a discerning world. Evening wear, business wear, make your mark on the world ladies. Our tailors will custom fit everything to your exact measurements and desires to accentuate the most beautiful you.



AMEENA
Silk Dress 740eb
Gloves 40eb
panties 50eb



D20
Coat (sp:10) 650eb
Dress 760eb
Boots 200eb



D20
Dress 690eb
Gloves 115eb
Boots 600eb
Glasses 240eb
Rabbit Fur Coat
22,560eb
Jewel Encrusted Dog
Collar 15,000eb



DLK
Dress 280eb
Shoes 70eb



ANRI
Jacket 700eb
Blouse 320eb
Skirt 250eb
hose 140eb



D20
Hat 275eb
Jacket 690eb
Blouse 240eb
Skirt 300eb
Shoes 190eb



DIGI
Dress 310eb



Doll
Ballerina Dress 200eb
Hose 50eb



Eiko
Wedding Dress 2350eb



Eiko
Bridesmaid Dress 510eb
Shoes 150eb
Gloves 40eb



Faye
Dress 1230eb
Gloves 120eb
Gold Cigarette Holder 250eb



Eiko
Wedding Dress 1760eb
Shoes 300eb
Gloves 400eb
Tiara 4230eb
Necklace 8210eb
Earrings 2450eb
Bracelets 5500eb



Flipation
Chromasilk Dress 280eb
Chromasilk gloves 80eb



GCG
Black Dress 740eb
Boots 120eb
Gloves 100eb



Gothika
Black dress 820eb
Hat 200eb
Choker 50eb
White Dress 1100eb



Gothika
Leather Dress 675eb
Boots 150eb
Bag 200eb



Hyung-Tae Kim
Dress 2365eb
Leggings 200eb
shoes 235eb
Fans 120eb



Hyung-Tae Kim
Dress 1250eb
Shoes 300eb
Gloves 115eb



Hyung-Tae Kim
Dress 760eb
Coat 450eb
Hose 230eb
Shoes 400eb



Hyung-Tae Kim
 Dress 1240
 Hat 125eb
 Gloves 90eb
 Shoes 270eb



Hyung-Tae Kim
 Dress 1235eb
 Stockings 320eb
 Boots 260eb



Hyung-Tae Kim
 Dress 450eb
 shoes 300eb
 Hat 130eb



Hyung-Tae Kim
 Dress 540eb
 Bow 120eb
 Leggings 155eb
 Black Bodysuit 890eb



Hyung-Tae Kim
 Kimono 980eb
 Leggings 270eb
 Shoes 435eb



Hyung-Tae Kim
 Dress 2675eb
 Gloves 150eb
 hat 200eb



Hyung-Tae Kim
 Yellow Dress 1120eb
 Stockings 200eb
 Shoes 245eb
 Grey top 650eb
 Pants 465eb



Hyung-Tae Kim
 Dress 1230eb
 Hose70eb
 shoes 230eb



Hyung-Tae Kim
 Dress 920eb
 Shoes 190eb
 Hat 120eb



Hyung-Tae Kim
 Top 269eb
 Skirt 370eb
 Cloak 300eb
 Shoes 400eb



Hyung-Tae Kim
Dress 820eb



IRON GIESHA
Kimono 1650eb



MILANO
Dress 120eb
Gold Bracelet 400eb
Earrings 650



Ridere
Dress 1220eb
hose 180eb
gloves 80eb



Hyung-Tae Kim
Dress 400eb
Stockings 200eb
shoes 160eb



JULIAS
Dress 675eb
hose 60eb



Perspective
Dress 260eb
Shoes 75eb

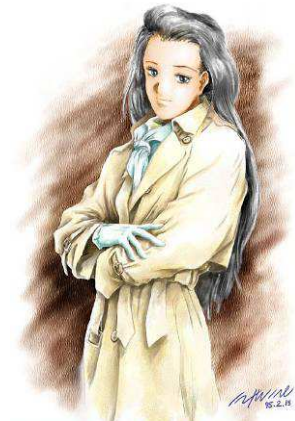

Original Lineart: Kim Hyung-tae (jw27281@aol.com)
Digital Coloring: Oho Toole-jin (magnum@nms.net)

SATCH
Purse 200eb
Quest
Coat (SP:12) 456eb
Scarf 60eb
Gloves 65eb



Hyung-Tae Kim
Kimono 4657eb
Shoes 465eb
Umbrella sword 500eb



Maclaine
Dress 875eb

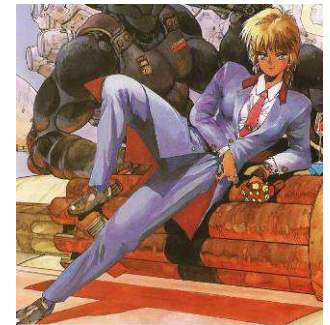

Shirow Studios
Suit 650eb
Tie 60eb
Blouse 50eb
Shoes 165eb

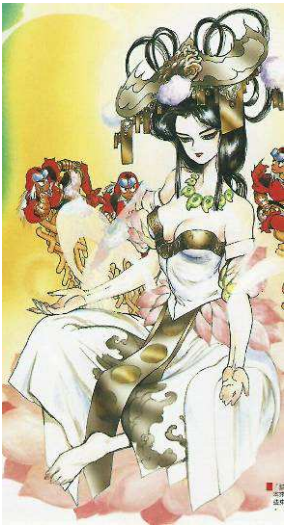

**Shirow Studios
Dress 4326eb
Headdress 986eb**



**Shirow Studios
Dress 850eb**



**Shirow Studios
Wedding Dress 2575EB
Shoes 1145eb
Gloves 80eb**



**Shirow Studios
Dress 820eb
Head dress 90eb**



**Shirow Studios
Dress 3275eb
Headdress 1015eb**

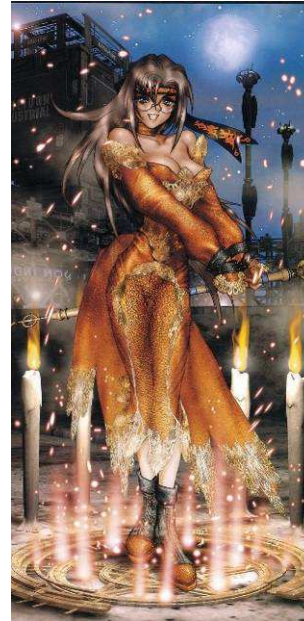

**Shirow Studios
Dress 2365eb
boots 23eb**



**Shirow Studios
Dress (available in
regular or open front)
3245eb
fan 80eb**



**Shirow Studios
Dress 1055eb
Headress1205eb**



**Shirow Studios
Kimono 1450eb
Scarf 60eb
Umbrella 180eb**



Shirow Studios
Suede Jacket 430eb
Blouse 260eb
Suede Skirt 380eb
Briefcase 200eb
Shoes 300eb



Shirow Studios
Dress 865eb



Shirow Studios
Chromasilk Dress
500reb
Sleeves 80eb



Shirow Studios
Dress 970eb
Luminescent Arm
Wraps 500eb



Shirow Studios
Suit (SP:10) 965eb
Boots (SP:10) 310eb



Shirow Studios
Dress 740eb
shoes 210eb



SNK
Silk Shirt 320eb
Silk Skirt 400eb
Velvet Vest 250eb



Spoon
Dress 550eb
Gloves 200eb
Shoes 370eb



Tekka
Dress 520eb
Hose 150eb
Shoes 190eb
Gloves 60eb



Vanguard
Dress 875eb
Boots 450eb



PANDEMONIUM

URBANWEAR

THE ABSOLUTE HEIGHT OF FASHION FOR THE TRENDY OF ALL AGES. CREATE A LOOK THAT TELLS PEOPLE WHO YOU ARE.

CHOOSE FROM THE TOP DESIGNERS.



AEON
Shirt 140eb



ARIANNA
Top 105eb
Skirt 85eb
Trench (SP:8) 665eb
Boots 175eb



BETTY
Dress 200eb
Fishnets 125eb



BLADE
Leather shirt 220eb



ANDROID
Top 185eb
Pants 65eb



BF
Suit (SP:6) 720eb
Mask (with space for 3
cyberoptic options)
560eb



BLAME
Bodysuit (SP:12)
3500eb



ASSASSIN
Bodysuit 690eb
Boots 750eb
Vest 200eb



BLADE
Coat (SP:14)
Bodysuit (SP:4) 200eb
Dynalar SSPR
Smartgoggles (4
cyberoptic options, 1
cyberaudio option)
385EB



APPLE
Armorkini (SP:12)
650eb
Leggings (SP:12) 400eb



BLOODLINES
Dress (Torso SP: 15)
13,4465eb
Gloves 6004b
Mask 400eb



BLOODLINES

Jacket 985eb
Pants 320eb
Gunbelt 350eb
Open Toed Boots
1450eb
Smart Goggles (SP:5 4
cyberoption slots)
2675eb
Sword (Combat quality)
750eb



BORDON

Unitard 200eb
Shorts 50eb
Leggings 65eb
Shoes 95eb
Gloves 25eb



CHUNI

Bodysuit 345eb
Vest 120eb
Shoes 80eb



COQUETTISH
Unitard 300eb
Leggings 550eb
Jacket 240eb
Shoes 120eb
Gloves 85eb



BORDON

Unitard 60eb
Stockings 50eb
Gloves 50eb



Braddock

Leotard (w/ gloves and
boots) 215eb



COLWYN

Sport top 80eb
Pants 130eb
Boots 120eb
Backpack 80eb



D20

Suit 560eb
shirt 80eb
Shoes 210eb



CHALK

Vest (SP:8) 650eb
Short overalls 320eb
Boots 120eb



CORMA

Armor Vest (SP:10 W/
SP:14 Shoulder pads)
675eb



DEUS

Dress 220eb
Gloves 45eb
Boots 70eb



DEUS
 Dress 280eb
 Hose 30eb
 Boots 120eb



DEUS
 Coat 450eb
 Pants 230eb
 Shoes 155eb



EPEC
 Trench (SP:16) 340eb



ELECTRIC
 Lumifiber/Leather
 Jacket 535eb



ELECTRIC
 Lumifiber Dress 450eb



EROTEK
 Spray On Clothing
 (using a new form of
 latex, and a
 computerized spray jet
 which works the same
 as your ink jet printer,
 you can literally spray
 any variation you like.
 The Latex quick
 solidifies and is peeled
 off when done. Not for
 extended wear, since
 going to the bathroom
 will ruin your outfit.
 One can of Spraysuit
 will last for 5
 applications, and you
 can program any
 variation into the
 sprayer) 500eb per can
 Nostick Panties 140eb



DEUS
 Jacket 400eb
 Blouse 85eb
 Pats 215eb
 Boots 175eb

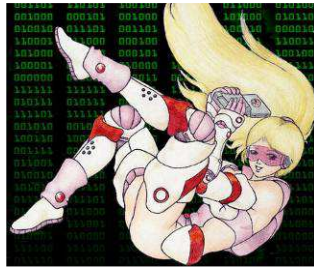

DJAKE
 Armor Sleeves (SP:16)
 650EB
 Armor Boots (SP:16)
 780eb



DMC
 SHORT SUIT 420eb
 Boots 310eb
 Shades 120eb



ELECTRIC
 Lumifiber Opera Cloak
 560eb



ELECTRIC
 Lumifiber Jacket 470eb



GEF
 Ruffled Collar
 Leather Jacket 650eb
 Pants 500eb
 Boots 350eb
 Gloves 60eb
 Kneepad 200eb
 Scabbard 150eb



GORREM
 Top 310eb
 Shorts w/ Leggings
 350eb
 Boots 200eb
 Gloves 80eb



Equilibrium
 Chain woven Hakama
 (SP:12) 1200eb
 Gloves 80eb



GARANUM
 Unitard 200eb
 Boots 320eb
 Gloves 140eb
 Smart Goggles (4 optic
 options, 4 audio
 options) 1150eb



FLANTY
 Shirt 120eb
 Pants 145eb
 Boots 130eb



GOGIRL
 Jacket 430eb
 Leggings 220eb
 Go Inline Skates 160eb



JAKE
 Jacket (SP:8) 450eb



Copyright (C) gabarble
 nitid brenting - CGMkwork.com | CGFpk.com
Gabarble
 Leather Leotard 405eb
 Thigh Boots 325eb
 Gloves 100eb



GOGIRL
 Sport Bra 60eb
 Pants 120eb
 Backpack 140eb
 Waist pack 80eb
 Hat 65eb



GEF
 Armored Robe (SP14)
 1560eb
 Hat 150eb



GOGIRL

Leotard 250eb
Leggings 220eb
Gloves 205eb
Vest 85eb
Shoes 230eb



Hyung Tae Kim
Datafilm 650eb
Armored Leggings
(SP:10) 745eb
Armored Gauntlets
(SP:10) 520eb
Armored Shoulder Pad
135eb



Hyung-Tae Kim
Coat (SP:14) 1050EB
Pants 520eb
Shoes 245eb



Hyung Tae Kim
Coat (SP:8) 2885eb
Boots 240eb
Gloves 60eb



GOHA

Double breasted jacket
9245eb
Silk Cravat 200eb
Wrap 659eb
Dress 16,977eb
Gloves 975eb
Dinner Jacket 4565eb
Vest 1370eb



Hyung-Tae Kim
Coat 465eb
Suit 750eb
Jacket 370eb
Vest (SP:4) 325eb
Panties 80eb



Hyung-Tae Kim
Bodysuit (SP:4) 700eb



Hyung-Tae Kim
Top 820eb
Shorts 310eb
Leggings 285eb
Shoes 200eb



HEROES

Armored Bodysuit
(SP:12) 680eb
Gauntlets 150eb
Smartshades (4
options) 520eb
Leather Bodysuit (SP:8)
540eb
Duster (SP:10) 600eb
Datafilm (SP:4) 370eb
Silk Sleeveless Trench
335eb
Silk Pants 185eb



Hyung-Tae Kim
Dress (SP:4) 820eb
Boots (SP:4) 365eb



Hyung-Tae Kim
Bodysuit 1815eb
Shoes 230eb



Hyung-Tae Kim
Coat (SP:10) 1920eb
pants 350eb
shoes 135eb



Hyung-Tae Kim
Leotard 3200eb
Pants 650eb
Shoes 90eb



HYUNG TAE KIM
Jacket 850eb
skirt 300eb
Leggings 720eb
shoes 400eb
Hat 100eb
Gloves 165eb



Hyung-Tae Kim
Top (SP:4) 460eb
Pants 1530eb
Sleeve 95eb
Shoes 225eb



Hyung-Tae Kim
Jacket 400eb
Pants 320eb
Shoes 120eb



Hyung-Tae Kim
Dress 350eb



Hyung-Tae Kim
Pants 160eb
Boots 200eb
Gauntlets (SP:12)
405eb



Hyung-Tae Kim
Dress 300eb
Hat 40eb
Shoes 75eb



Hyung-Tae Kim
Top (SP:6) 605EB
Pants 360eb
Shoes 110eb



Hyung-Tae Kim
Kimono 1780eb
Panties 60eb
Shoes 230eb



Hyung Tae Kim
Datafilm 3500eb
Jacket 520eb
Shoes 235eb



Hyung-Tae Kim
Dress 735eb



Hyung-Tae Kim
Top 450eb
Skirt 325eb
Fishnets 115eb
Shoes 140eb
Gloves 85eb



Hyung-Tae Kim
Dress 795eb



Hyung-Tae Kim
Top 450eb
Skirt 380eb
Legging 75eb
Boots 150eb
Panties 50eb



Hyung-Tae Kim
Bodysuit 1120eb



Hyung-Tae Kim
Top (SP:6) 820eb
Skirt (SP:6) 765eb
Legging (SP:6) 505eb
Shoes 140eb
Luigi-Franchi Crossbow
(4d6) 1450EB



Hyung-Tae Kim
Bodysuit 250eb
Boots 215eb
Scarf 50eb

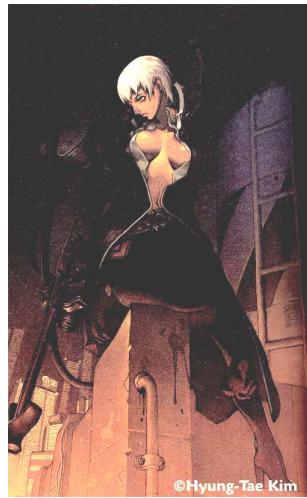

Hyung-Tae Kim
Dress 1895eb



Hyung-Tae Kim
Top 195eb
Skirt 165eb
Hose 80eb

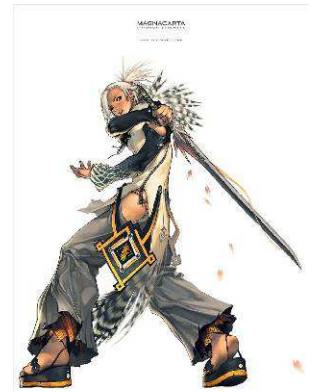

Hyung-Tae Kim
Shirt 810eb
Pants 1665eb
Shoes 205eb



Hyung-Tae Kim
Dress 720eb
Jacket 550eb



Hyung-Tae Kim
Shirt (SP:4) 1565eb
Pants 1670eb
Shoes 500eb



Hyung-Tae Kim
Blouse (SP:4) 685eb
Skirt 240EB
Thigh Boots (SP:6)
490eb
gloves 85eb



Hyung-Tae Kim
Jacket (SP:6) 740eb
Vest (SP:4) 325eb
Pants 660eb
Shoes 190eb



Hyung-Tae Kim
Dress 540eb



Hyung-Tae Kim
 Vest 875eb
 Pants 760eb
 Shoes 120eb
 Gloves 125eb



Hyung-Tae Kim
 Shirt 320eb
 Pants 380eb



IONEN
 Top 125eb
 Shorts 95eb
 Leggings 65eb
 Boots (SP:10) 185eb
 Sleeves 30eb



KALOR
 Vest 165eb
 Jeans 370eb



Hyung-Tae Kim
 Dress 890eb
 Leggings 60eb
 Shoes 160eb



Hyung Tae Kim
 Shirt (SP:4) 910eb
 Dual Holster 200eb
 Pants 650eb
 Shoes 320eb
 Gloves 95eb



JETTO
 Top 375eb
 Shorts W/ Bellbottom
 Leggings 400eb
 Shoes 95eb



K-Hos
 Body Suit 120eb
 Rigid Half-Skirt 75eb
 Boots 50eb
 Gloves 30eb



Hyung-Tae Kim
 Vest 215eb
 Datafilm (SP:6) 920eb
 shoes 120eb



IMAGINE
 Leotard (SP:4) 340eb
 Leggings (SP:4) 260eb
 Shoes 225eb



Lumina
Lumifiber Top 300eb



LUMINA
Lumifiber Kimono
650eb



LUMINA
Lumifiber Muscle Shirt
275eb



LUMINA
Lumifiber Top 400eb



MATOKO
Bodysuit 785eb
Boots 849eb



©2002 May-Be



©2002 May-Be

MAY-BE SOFT
Dress 420eb
Stockings 100eb



MADWOMAN
Leotard (SP:4) 200eb
Boots (SP:8) 400eb



MISS PRISS
Top 100eb
Skirt 135eb
Legging 95eb
Shoes 180eb



Moondog
Kimono 480eb



MOYACHICHE
Top 120eb
Panties 40eb
Leggings 80eb
Shoes 130eb



NAGEL
 Jacket (SP:10) 650eb
 Skirt 450eb
 Purse 520eb



NOVINK
 Top 85eb
 Half-Pants 365eb
 Half-Jacket 420eb
 Legging 80eb
 Belt 120eb
 Boots 190eb



SADY
 Dress 785eb



SEVU
 Gynoid Bodysuit
 3150eb



NEPOL
 Dress 240eb
 Shoes 100eb



PIMOLO
 Racing suit (SP:4)
 300eb



ROGET
 Top 250eb
 Pants 410eb
 Shoes 205eb
 Gloves 110eb



SEVU
 Jacket (SP:10) 210eb
 Leotard (SP:4) 180eb
 Leggings (SP:4) 200eb
 Boots 145eb



Shirow Studios
 Bondage wrap Leotard
 560eb
 Leather Strap Thigh
 Boots 1650eb



Shirow Studios
 Corset 320eb
 Nipplecups 120eb
 Boots 400eb
 Gloves 110eb
 Panties 95eb



NEPOL
 Plasticsilk Blouse
 1100eb



**Shirow Studios
Bodysuit (SP:4) 630eb**



**Shirow Studios
Blouse 120eb
Pants 200eb
Shoes 140eb**



**Shirow Studios
Body suit 870eb
Boots 210eb
Gloves 120eb**



**Shirow Studios
Arabian Nights Dress,
535eb
Hat 69eb
Shoes 40eb
Jumpsuit 200eb
Helmet 185eb
boots 130eb
Muscle shirt with SP:15
shoulder pad 190eb
Blouse (SP:6) 680eb
Pants 240eb
Armor Boots (SP:10)
420eb
Hat 75eb**



**Shirow Studios
Datafilm 1240eb
Armor Sleeves (SP:15)
530eb**



**Shirow Studios
Bodysuit (SP:4) 740eb
Gloves (SP:4) 370eb
Shoes 200eb**

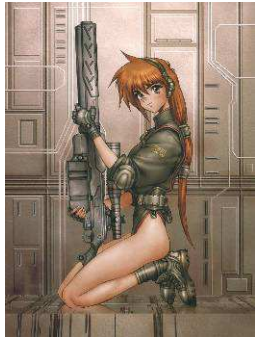

**Shirow Studios
Body suit 675eb**



**Shirow Studios
Leotard (SP:8) 270eb
boots 200eb**



Shirow Studios
 Top 420eb
 Skirt370eb
 Gloves 120eb
 Hat 210eb

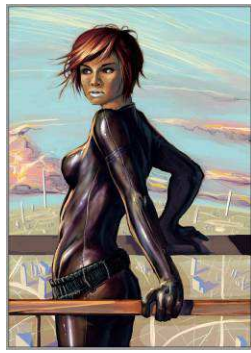

SKETCH
 Bodysuit 150eb
 Belt 45eb



T'CHALLA
 Dress 420eb
 Shoes 140eb



TEKKA
 Shirt 250eb
 Pants 210eb
 Boots 235eb



SIN
 Blue Jacket 450eb
 Yellow Pants 500eb
 Red Jacket 675eb
 Black Pants 450eb



SPYKE
 Pants 230eb
 boots 100eb



TEKKA
 Dress 220eb
 Shorts 40eb
 Hose 20eb
 Gloves 40eb
 Boots 75eb



TEKKA
 Top 420eb
 Shorts 150eb
 Boots 560eb
 Cape 250eb
 Gloves 210eb



SIN
 Bodysuit 450eb



TC
 Datafilm (SP:4) 480eb



TEKKA
Wedding Outfit 3450eb



TREECE
White Jacket 190eb
Black Shirt 70eb
Pants 200eb
Bodysuit (SP:4) 250eb
White Shirt 50eb



UKITAKAMUKI
Bodysuit 6500eb
Helmet (SP:10) 400eb
Shoulder pads (SP:12) 250eb

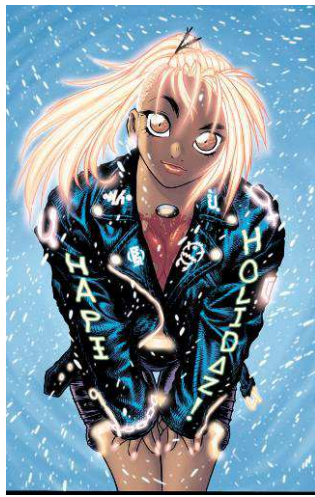

WARRENWEAR
Illumati Leather Jacket 1345eb



WOTCH
Trench (SP:10) 700eb
Shirt 60eb
Pants 95eb



Yoshio
Shades 125eb (room for 2 cyberoptic options)
Jacket (SP:12) 575eb



ZERO
Dress 280eb



ZIVA
Ribbon One-piece 254eb
Gloves 240eb
Boots 380eb



ZIVA
Metasilk Shroud 1250eb
(The shroud is made from a very strong, but very thin material, it clings naturally to the body, but weighs enough to drape, the properties of the material give a certain "shrink wrapped" look to the wearer. It also acts as a flexible 2 way mirror, while still allowing air to move through as easily as it would cotton.)

KITTY CAT BOUTIQUE

SPECIALIZING IN LINGERIE AND SWIMWEAR FOR THE DISCRIMINATING CUSTOMER.



Proprietor Kitty Preston runs this business out of the second level of the Nakajimo Shopping complex. It is stocked with high end designer lingerie and swimsuits, and has a back room for "adult" costumes, with large selection of vinyl and leather wear.

LINGERIE



2NGAW
Panties 20eb
Shoes 165eb



Aphrodite
Bra 25eb
Panties 30eb
Gloves 50eb



BAKANEKONEI
Camisole 135eb
Bodice 170eb
Panties 45eb
Stockings 35eb



CP DESIGNS
Teddy 50eb
Choker 15eb



AARPENIUM
Bra 40eb
Panties 30eb
Leggings 20eb
Shoes 65eb



ALLDAY
Bra 65eb
Panties 75eb
Socks 8eb



Cassandra
Shirt 25eb
Panties 15eb



DAPO
Pajamas 55eb



Dapo
Camisole 40eb
Shorts 20eb



Galhound
Jacket 200eb
Panties 40eb
Corset 70eb
gloves 60rb
Leather Stockings 85eb
Boots 120eb

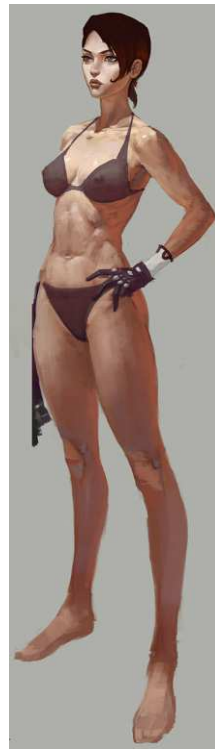

GORREM
Bra 25eb
Panties 15eb



HELLEN
T-shirt 20eb
Panties 15eb
Socks 8eb



DAPO
Corset 120eb
Panties 40eb
Garter 65eb
Nylons 40eb



GENEKRUGER
Camisole 185EB
Panties 65eb



Gusli Girl
Silk Nightshirt 50eb
Panties 25eb



Hyung-Tae Kim
White Camisole 60eb
Black Camisole 65eb
Panties 20eb
Nylons 35eb



DAPO
Vinyl coat 160eb
Leather Teddy 230eb
Boots 120eb



Gusli Girl
Sailor Top 30eb
Pink Neckerchief 10eb
Panties 30eb
Nylons 30eb



KARANAK
Blouse 45eb
Skirt 30eb
Panties 20eb
Stockings 15eb
Shoes 40eb



KARANAK
 Shirt 40eb
 Sports Bra 20eb
 Panties 40eb
 Socks 5eb



Lumina
 Lumifiber Plstisilk
 Bodice 300eb



MILLA
 Teddy 75eb



Miss Priss
 Teddy 200eb
 Leggings 75eb
 Gloves 50eb



KUROITORA
 Panties 20eb



Mabulle
 Thong 40eb
 Shirt 25eb

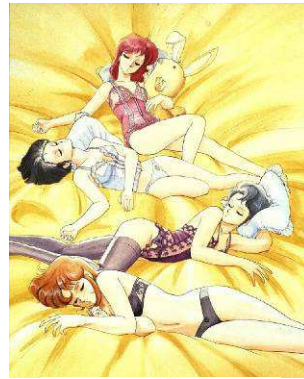

LARKABELLA
 Camisole 250eb
 Panties 65eb



MILLA
 Bra 45eb
 Panties 30eb



Miss Priss
 Pink Camisole and
 panties 50eb
 White camisole and
 panties 45eb
 Purple Teddy 70eb
 Nylons 30eb
 Black Bran and Panties
 50eb

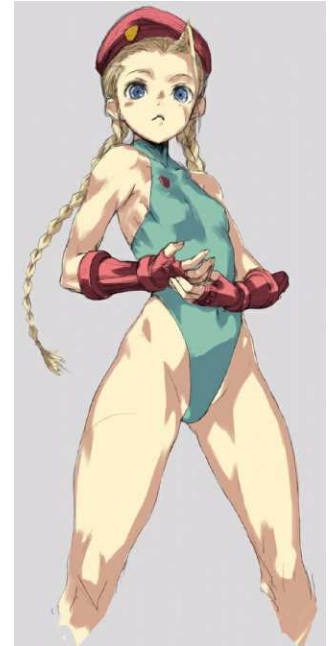

MOE
 Unitard 50eb
 Gloves 25eb
 Beret 25eb



MOLINARA
Tank Top 25eb
Panties 30eb
Socks 2eb



NAKAY
Shirt 30eb
Camisole 45eb
Tank Top 25eb
Panties 30eb
Socks 5eb



PRINCE
Halter 25eb



REDCAT
Nightshirt 35eb
Panties 25eb

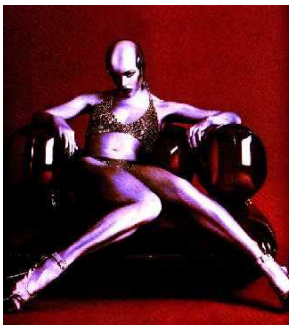

Naomi
Bra and Panties 40eb



PRINCE
Teddy 55eb
Shoes 75eb



PRINCE
Tank Top 20eb
Panties 153b



RGUS
Shirt 20eb
Panties 30eb



NAOMI
Unitard 40eb



RED
Sport Bra 30eb
Women's Briefs 20eb



RYU'S FORM
Corset 245eb
Panties 40eb
Stockings 85eb
Gloves 35eb
Choker 20eb



SCAVENGER
Bra 75eb
Panties 40eb
Socks 12eb



Shirow Studios
Camisole 65eb
Gloves 40eb
arm bands 25eb
Tiara 20eb

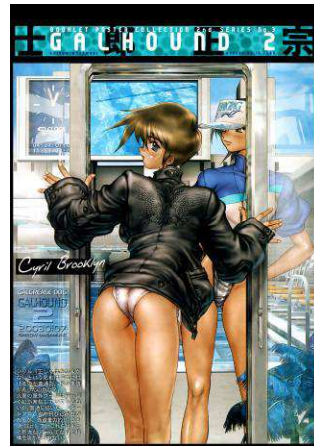

Shirow Studios
Leather Jacket 260eb
Panties 40eb



SMS
Panties 20eb



SHED
Bra 110eb
Gloves 89eb
Stockings 65eb



Shirow Studios
Teddy 89eb
Skirt 45eb
Shirt 30eb
Sebuuro shoulder
holster 60eb

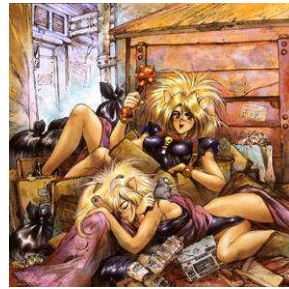

Shirow Studios
Black
teddy 70eb

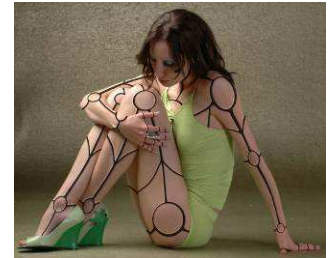

SOLKE
Top 20eb
Panties 15eb
Shoes 45eb



Shirow Studios
Panties 60eb
Shirt 45eb



Shirow Studios
Bra and Panties 70eb
Anklets and Bracelets
40eb

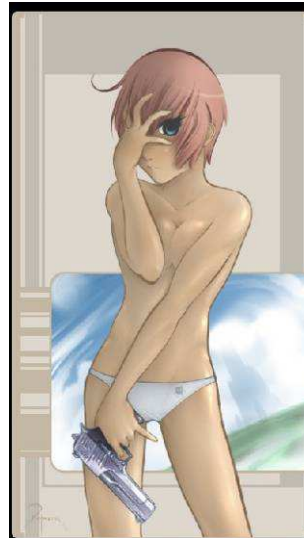

Silky Doll panties 15eb



STUDIO GAIJIN
Camisole 30eb
Panties 25eb



THEDAVE
 Nightshirt 35eb
 Panties 20eb
 Socks 18eb



THEDAVE
 Camisole 85eb
 Panties 32eb
 Stockings 35eb



THEDAVE
 Leotard 160eb
 Gloves 30eb
 Shoes 50eb

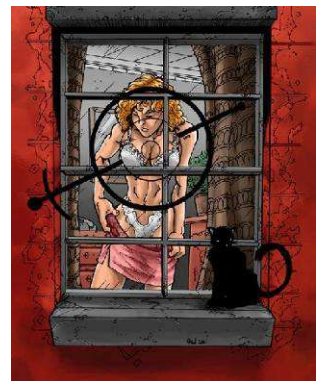

Wildstorm
 Bra and Panties 50eb
 Skirt 30e



YanYan
 Top And Bottom 80eb



THEDAVE
 Nightshirt 40eb
 Panties 20eb
 Socks 25eb



THEDAVE
 Boxers 10eb



TIFFANY
 Bra 50eb
 Panties 30eb
 Garterbelt 85eb
 Stockings 50eb



YANYAN
 Top 30eb
 Panties 25eb
 Stockings 30eb
 Vest 50eb
 Hat 40eb
 Shoes 75EB
 Bracelet 200eb
 Purse 350eb
 Genperfect Pet 3500eb

SWIMWEAR

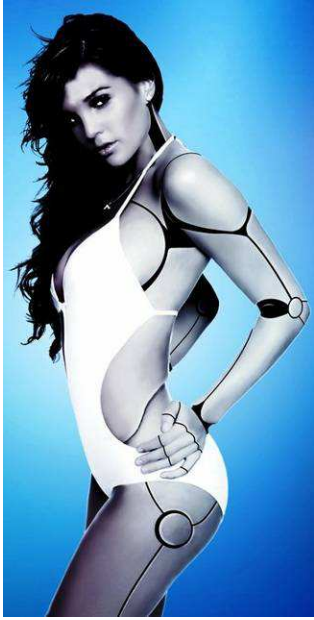

ACID BURN
One-piece 45eb



ACID BURN
One-piece 65eb
Boots 135eb
Bracelet 25eb



Bebop
Black and white bikini 50eb
Green wetsuit 40eb
Blue Trunks 20eb

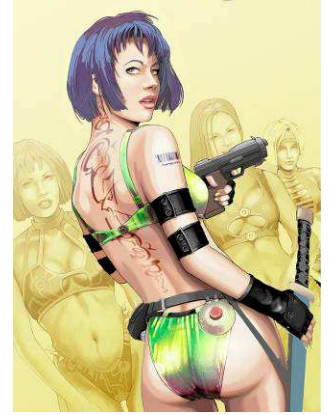

Cavell
Bikini 50eb
Arms Bands 10eb
apiece



ACID BURN
Bikini 38eb
Shoes 65eb



AYA
bikini 25eb
Net wrap 40eb
Bandana 10eb
Shoes 60eb



BORDON
Bikini 50eb
Leggings 35eb

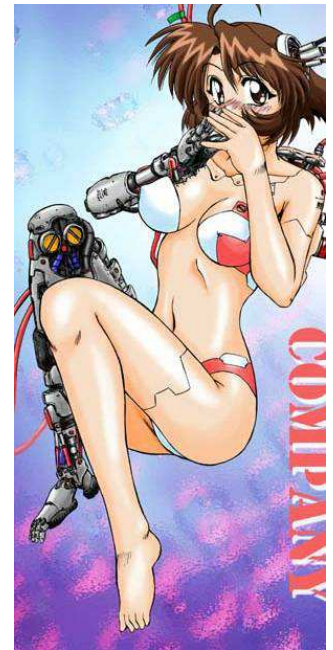

COMPANY
Majestick Bikini 90eb



ACID BURN
One-piece 50eb
Shoes 200eb



Bebop Fashions
2-piece 30eb



BOSAMA
Majestick Bikini 345eb



CYB
Two-Piece 55eb



Cyberia
Vinyl Bodysuit 160eb



DEAD ROBOT
Bikini 30eb
Arm wraps 25eb
Boots 75eb
Headphones 60eb



FUCHSIART
One-piece 42eb
Jacket 20eb
Pants 35eb
Shoes 65eb

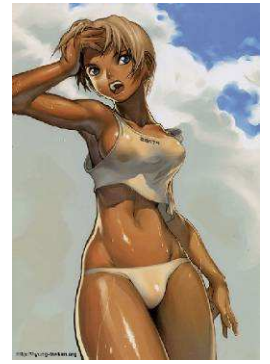

Hyung-Tae Kim
White bottoms and
Halfshirt 25eb



Dapo
One-piece 35eb



DELIRIUM
Bikini 20eb
Bunny Clock Necklace
45eb



HARUAKAI
Bikini 20eb



Hyung-Tae Kim
Men's Trunks 15eb
Two-piece 30eb



DBZ
Bikini 25eb



EL PINOY
Bikini 95eb
Gloves 50eb
Leggings 40eb
Hat 20eb
Headphones 70eb



Hyung-Tae Kim
Top 40eb
Sarong 50eb
Sandals 45eb

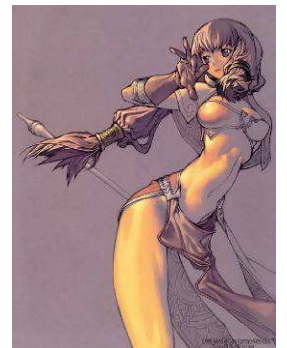

Hyung Tae Kim
Bikini 65eb
Sarong and wrap 30eb



INCEPTION
Thong 35eb
Jacket 50eb



KUNKKA
Bikini 50eb
Shoes 75eb



MARKOVA
Bikini 30eb
Shirt 20eb
Shoes 70eb



MOE
Bikini 68eb
Sarong 20eb
Gloves 40eb
Ribbon 5eb



Mumah
Bikini 40eb



OKASAKA
Bikini 40eb
Boots 60eb
Gloves 20eb



LODOSS
WET SUIT 180eb



MISHAMOSTYLE
Bikini 28eb



MOLYBDENUM
White Bikini 55eb
Black Bikini 60eb
Sun Visor 10eb



Miss Priss
Pink suit 50eb
Colorful bikini and
sarong 30eb
One-piece 20eb
Red Bikini 30eb



RYU'S FORM
One Piece 65eb
gloves 20eb



MACREA
Bikini 35eb
Hat 40eb
Bracelet 25eb
Sunglasses 30eb

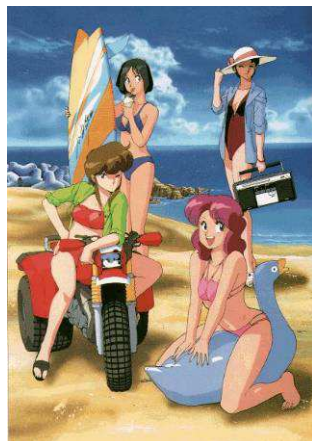

Miss Priss
One piece 25eb
Blue Bikini 30eb
Red Two-piece 25eb
Pink Bikini 40eb



MORT TANU
Majestick One Piece
154eb
Bracelet 30eb



RYU'S FORM
One Piece 70eb



1 SITE #261

RYU'S FORM
 Bikini 65eb
 Waterproof Watch 30eb
 Sandals 35eb
 Ankle Purse 20eb
 Anklet 50eb
 Boogie Board w/carry strap 120eb

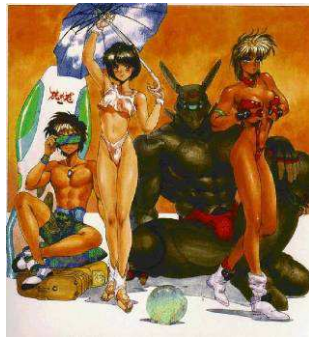

SHIROW STUDIOS
 Bahama trunks 20eb
 Red Speedo 30eb
 Pink two-piece 50eb
 Red One-piece 65eb



Shirow Studios
 Bikini and half shirt 30eb



Shirow Studios
 Two-piece 60eb



SINKI
 Bikini 55eb



Summer
 Bikini 55eb



THEDAVE
 Bikini 75eb
 Belt 30eb
 Boots 90eb
 Gloves 45eb



THEDAVE
 Wetsuit 120eb
 Goggles 30eb
 Watch 65eb



THEDAVE
 One-piece 30eb
 Shoes 85eb
 Belt 40eb
 Gloves 25eb
 Cap 10eb
 Goggles 15eb



ZIVA
 Wetsuit 150eb
 Snorkel and Mask 25eb



ZIVA
 Wetsuit 165eb

FETISH COSTUMES



ALRIGHT
Corsette 60eb
Stockings 50eb
Shoes 40eb



Hyung-Tae Kim
Christmas Vinyl 430eb



MOLBDENUM
Vinyl One-Piece



Synergy
Leather Suit and mask
400eb



MOLYBDENUM
Corset 470eb
Garter and Stockings
120eb
Gloves 95eb
Eye Patch 60eb
Boots 100eb
Whip W/Beads 853b



Shirow Studios
Top 30eb
Leather Jacket 120eb
Chaps 150eb
Hat 40eb
panties 20eb
gloves 30eb
Boots 60eb



TSR
Armored Bikini 2500eb
Leggings 1800eb
Gauntlets 750eb



Galhound
Leather bondage body
suit 560eb



GALHOUND
Police uniform 320eb



MOLYBDENUM
One Piece 850eb
Boots 475eb
Gloves 140eb
Collar 50eb Umbrella
55eb
Mask 35eb
Feather Boa 25
Cage 520eb



Soryama
Chain and vinyl top
220eb
Gloves 50eb
Panties 20eb
Hose 40eb

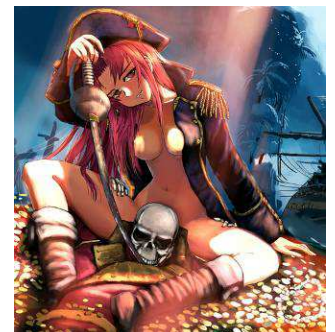

TSR
Priae Jacket 400eb
Pirate Hat 35eb
Boots 185eb



THE COMBAT ZONE

Clothing and Armor



Whether for the mean streets of Night City, or for Hot demilitarized zones in exotic locations, The Combat Zone is your source for the latest in rugged clothes, military surplus uniforms, footwear, and BDU's, stealth gear, and armor available to the private citizen. We also carry a large selection of Datafilm from top designers.

COMBAT WEAR



AMBRIL
Tactical Vest (SP:10)
150eb
Ammo tac gear 30eb



AMBRIL
Muscle Shirt (available in a variety of colors, will custom print any logo for an additional 10eb) 15eb
SP:8 elbow and knee pads 40eb per pair
Tactical Pants 60eb
Climbing boots 60eb



APPLESEED
Tactical Vest (SP:10)
150EB (250eb for FBC sizes)



APPLESEED
Police Issue Jumpsuit 50eb
Cap 20eb
Boots 75eb
(Normal uniformed duty officers wear Blue Jumpsuits with white vests and helmets. SWAT officer uniforms vary in that they wear Black jumpsuits with gray vests and helmets, and C-SWAT personnel wear gray jumpsuits and blue armored vests and helmets.)



AMBRIL
Heavy Leather Pants (SP:4) 150eb
Boot Sheath 10eb
Shoulder Holster 20eb



Appleseed
Heavy Leather Vest (SP:6) 120eb
(280eb for FBC sizes)



APPLESEED
Leather Muscle Shirt 45eb



APPLESEED
Jumpsuit 40eb
Work boots 60eb

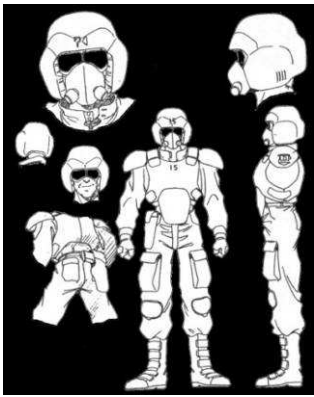

APPLESEED
Police Issue Motorcycle
Police Uniform

This uniform begins with the black jumpsuit, then instead of the relatively soft vest it applies a hard shell armored torso covering. It is a bit lighter, but offers slightly less protection (SP 18, 600eb) as it is more designed to protect from crashes than bullets. Still it is effective armor, and many of the C-SWAT officers prefer it. The helmet (SP 20 450eb) is also different and offers Low Light, Anti-Dazzle and a radio connected to their bike. The visor retracts into the helmet and the mask does not connect to an air supply, acting merely as a filter and facial armor. The uniform is completed with a pair of sturdy motorcycle boots.



APPLESEED
Police Issue Rain
Poncho 45eb
For cold weather and other inclement conditions, the NCPD are issued a rain poncho, usually kept in the trunk of their vehicle. The ponchos protect against both rain, and cold.

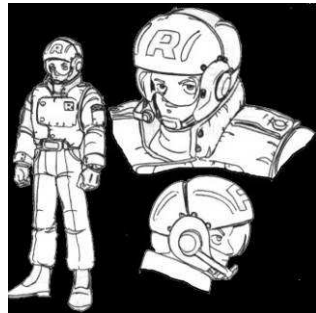

APPLESEED
Police Issue Helicopter
& Av Pilot's Uniform.
This uniform is worn by the pilots of the majority of AV's and helicopters used by the Night City Police Department. It consists of a dark blue flight suit (190eb) and a flight helmet (SP 20 550eb) with a built in radio (which connects to the aircraft's radio for stronger reception) and a visor that offers Heads-up display, Anti-dazzle, and Low Light.

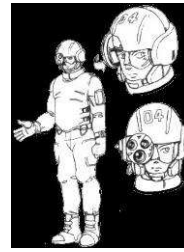

APPLESEED
Police Issue AV-
Bike/Mini-Copter Pilot
Uniform
There is another pilots uniform, and it is worn by the pilots of AV-Cycles and Mini-copters. The uniform is similar to the basic uniform, underneath the officer wears the same blue jumpsuit, and the same white vest (sans shoulder pads), but this uniform uses different slightly magnetically charged boots to offer stability and sure footing on the cycles, and a sophisticated helmet (SP:20 1650eb) with a full police radio, Low Light, Tele-optics Anti-dazzle, Heads-up display, and motion direct link to the various weapon systems of the craft (the link means that the gun tracks according to movement of the eye).



ARASAKA
Dog Tags 25eb
Personal means of Identification, these corporate dog tags are impact resistant, water and weatherproof. They contain a detachable storage device that has the employees complete medical history, basic identification, and other relevant information. The chip also acts as a cred stick, and can be read from nearly any computer on the planet.



ARASAKA
Coveralls 460eb
The standard battle dress uniform for Arasaka Combat Personnel. The standard issue to most troopers is dark blue. The legs have a padded stripe added running down the outside and inside of each leg, this is not merely cosmetic, it is functional, the pads actually contain a chemical compound that not only allows the soldier to adjust the uniforms temperature plus or minus 10 degrees, but also they disperse the soldiers heat signature somewhat, making them a bit less visible to IR and Thermographic detection. The basic armor vest and gauntlets also make use of this system, so it covers the entire body. While navy blue is the basic issue, and by far the most commonly seen, the jumpsuit (and its accessories) come in several different colors and camo patterns to suit any assignment. (The legs have 2 regular front pockets + the small change pocket, 2 large leg pockets, and 2 buttock pockets, the torso has 2 pockets on the front)



**ARASAKA
Gloves 45eb**
Strong rugged gloves with plenty of protection for the knuckles and fingers for hand to hand combat and rough terrain, also equipped with sure grip coating, (give a plus +1 to climbing). Often soldiers, will cut the fingertips off these gloves for greater comfort, dexterity, and weapon control.

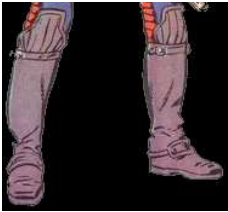

**ARASAKA
Boots 95eb**
(SP:10) Strong steel toed boots, with separated metal plates in the soles, to provide protection while maintaining flexibility. These basic issue boots also come with attached kneepads for comfort and protection.



**ARASAKA
T-Shirt 25eb**
Simple t-shirt with the Arasaka corporate logo. Different branches will have their division of service emblazoned underneath.



**ARASAKA
Cap 15eb**
As an alternative to the helmet, a cap may be worn, though this does not protect the anonymity of the troopers face.



**ARASAKA
Flight Suit**
Worn by most of the pilots in the Arasaka forces. It consists of a water/air tight g-suit (365eb) and a state of the art flight helmet (SP: 20, 1170eb) equipped with the most state of the most cutting edge technology available, including Low Light, thermograph, Image Enhancement, Anti-Dazzle, and tele-optics. The helmet also features a small hatch on the back that allows full cyber interface. For hands on action the helmet also comes with a flip down targeting scope and full visor.



**ARASAKA
Arctic Survival Gear 750eb**
For use in cold weather situations, this suit provides maximum warmth while remaining lightweight and flexible. Worn over a troopers standard armor, extra insulation is provided by a fur lining (Arasaka grown animals only) and the suit comes with an extra insulated helmet and a facemask that actually warms the air through small heated coils without giving off any additional heat upon exhalation. It also features a hood and a white back pack cover to maximize stealth in the snow.



**ARGENTINIAN
MILITARY
BDU'S** Consisting of a pair of loose pants (25EB) with standard rear and thigh pockets, and a Jacket (20EB) with stylish breast, upper and lower arm pockets. The Priests collar of the jacket is a popular look, and it is hollow to allow a thin gorget to be inserted (SP:8 10EB). The outfit comes in Grey, Black, Brown and Blue.



**ARGENTINIAN
MILITARY
Dress Uniform 385eb**
includes shirt, coat, pants, belt, boots, hat, tie and gloves. This is for formal situations and officers in non-combatant roles. The Argentinian Dress Uniform is more elaborate and stylish than most militaries in the world, it was designed by Jon Holloway, a top European designer who did it while vacationing in the country.



**ARGENTINIAN
MILITARY
HEAVY BELT 120eb**
The Argentinian heavy belt attaches to the thigh holster, and is able to attach a variety of pouches, ammo, and other gear. Typically the soldiers knee is worn on the back left side.



ARGENTINIAN MILITARY

POLICE UNIFORM

Just as in Mexico the Police in Argentina are actually another branch of the military. The Uniform at its most basic consists of the jumpsuit in grey or blue (20eb), the standard police helmet (SP: 20 350eb) equipped with Radio, and a flip down visor with Low-Light, IR, and Anti-Dazzle) and a "Soft" armored vest (SP:14 300eb). Officers assigned to the lightest duties are required to wear this. For heavier duties, including SWAT, Riot, and C-SWAT type situations, Argentinean police are issued a much heavier vest that includes groin protection (SP: 22 EV:-1 560eb), elbow and knee pads (SP:12 30eb), a heavier helmet (SP:25510eb) and a gas mask (80eb).



ARNESSON

Thermal Body Suit 70eb
(keeps wearer warm down to 20 degrees)
Thigh SMG holster 30eb
Shoulder Holster 20eb
Web Belt 15eb.



BERGSTROM

Cold Weather Coat 140eb
Cold Weather Pants Wit Built In Boots 265eb
Windbreaker Trench 120eb
Hat 80eb



BOKUMAN

Dataweave Bodysuit (SP:10) 780eb



BOLIVIAN UNIFORM-

The Bolivian style uniform is little more than jungle pattern camo pants (20eb) and a jacket (15eb) (often bought from different sources with different patterns), a hat (8eb), and a Helmet (SP:18 45eb), some of them even get vests (50eb), the vests themselves vary as much as the uniforms, as the Bolivians will buy them from whoever will sell them (SP:15 - SP:20 standard EV penalties), usually old surplus military or police vests. Again, these uniforms are standard in Bolivia, but are distributed among the SAA forces as well.

Bounty Hunter 2010



Bounty Hunter Heavy Leather Bodysuit (SP:4) 120eb
Boots 150eb



C&C

T-Shirts (available in men's and women's, a large variety of Police and military styles and colors) 15eb
Leather thigh boots for her 120eb



CELLFACTOR

Overalls 95eb
Boots 60eb
Tactical Vest (SP: 14) 200eb
Helmet (SP:20, built in smartgoggles) 240eb



CELLFACTOR

Datafilm 2400eb
 Torso Armor (SP: 14,
 built in hard drive)
 3200eb
 Arm Gauntlet (SP:16,
 Built in Cybermodem)
 4599eb
 Boots (SP:10) 960eb



CHILEAN MILITARY
 Dress Uniform

Includes shirt (25eb),
 coat (250eb), pants
 (300eb), belt (15eb),
 boots (65eb), hat
 (10eb), tie (5eb) and
 gloves (35eb). Chilean
 officers are expected to
 at least look like they
 are ready to join their
 troops in combat. The
 Officers jacket is lightly
 armored itself (SP:12
 EV-1) with add-on
 shoulder,back and
 chest plates (SP:10).
 Likewise the pants have
 an add-on thigh plate
 and cod protector
 (SP:10). A helmet
 identical to that of the
 soldiers is issued as
 well. The Chilean
 officer uniforms are bit
 overly elaborate, but
 definitely distinguish
 the officers from the
 rest of the soldiers.



CHINESE MILITARY
 Dog Tags 2eb

Simple tin tags with
 relevant information
 stamped on them,
 nothing fancy.



CHINESE MILITARY
 Standard Uniform 40eb

The standard all
 purpose uniform for the
 chinese military
 consists of one black,
 and one grey, cover all
 jumpsuit.



CHINESE MILITARY
 Pilots Uniform And
 Helmet-

A very standard
 flightsuit (85eb). The
 helmet (450eb) is SP:20
 and is equipped with
 Low-Light,
 Thermograph,
 Targeting Optics, and
 Anti-Dazzle.



CHINESE MILITARY
 Cold Weather Armor
 visually similar (and
 having the same SP
 rating) to their standard
 armor, the cold weather
 gear has much a much
 thicker padded and
 insulated cover all
 jumpsuit (75eb), atop
 this is worn a long thick
 robe (80eb) like layer.
 The gasmask (125eb)
 has a special heated
 coil which warms the
 air, and it to is covered
 with a heavy scarfing
 (15eb), which helps aid
 in camouflage as well
 as in keeping the
 soldier warm. The
 helmet (50eb), gloves
 (20eb), and boots
 (45eb) also all contain
 thicker padding and
 insulation. Winters in
 northern China and
 Tibet are cold, and
 Chinas cold weather
 specialists are second
 only to Russia's.



COLOMBIAN UNIFORM-

Columbians are the
 best funded of the SAA
 forces, they actually
 issue body armor to
 their soldiers, and have
 a relatively consistant
 uniform. The uniform
 consists of a pair of
 Khaki BDU pants, heavy
 combat boots, gloves, a
 Chinese wrist computer
 (with GPS, and short
 range radio), a helmet
 (SP:20) and a highly
 flexible and light
 armored vest (SP:15).
 It is believed that either
 the Chinese or
 Russians supplied the
 armor, or possibly
 both. This uniform is
 standard in Colombia,
 and widely distributed
 to Other SAA forces as
 well.



CLERIC

Coat (SP:20) 1196eb
 Gloves 50eb
 Boots 150eb



D20
Trauma Team Uniform
 240eb
 SP: 14 (torso) SP:10
 (shoulder and knee pads)



D20
Motocross Overalls
 80eb



D20
Coveralls 40eb
Tech Armor (SP:15 sealed against environment) 1300eb



D20
Jacket (SP:8) 210eb
Pants 140eb
Shirt 40eb
Boots 85eb
Gloves 60eb



D20
Combat and work coveralls (available in a variety of colors) 25eb
Tactical security vest (SP:18) 200eb
Web gear 40eb
Shoulder holster 35eb
Spats 10eb



D20
Media Coveralls 80eb
Netrunner headgear (A/V recorder, transmitter) 230eb



D20
Bodysuit (SP:4) 160eb
Gloves 20eb
Boots 70eb



D20
Top 20eb
Pants 45eb
Tool belt 50eb



DEAD 6
BDU Pants 35eb
Black underarmor T-shirt 20eb
Beret 15eb
Short boots 35eb
High Boots 50eb
Padded Mail shirt 150eb
Tactical Ammo vest 50eb
Kneepads (SP:10) 35eb



DEMONTECH
 Wetsuit 200eb
 Helmet (SP:15, acts as a dive mask and respirator) 780eb
 Emergency rebreather vest (2 minutes) 150eb



DOMINIC MARCO
 Vest 20eb
 BDU's Pants 40eb
 Boots 75eb



DYSON
 Blackblade Body Suit SP:4 (with SP:8 soft armor plates) 260eb



ENFORCER
 Dataweave Vest (SP: 6) 400eb
 Jumpsuit 40eb
 Gasmask 50eb
 Kneepads 20eb
 Boots 60eb
 Smartshades (2 options) 1000eb



EQUILIBRIUM
 Heavy Leather Jackets 200eb (SP:4)
 Motorcycle style combat helmet 80eb (SP:18)

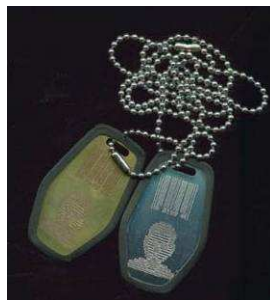

EUROPEAN DEFENSE FORCES
 Dog Tags 40eb
 Personal means of identification. Also acts as cred sticks at all EDF facilities.

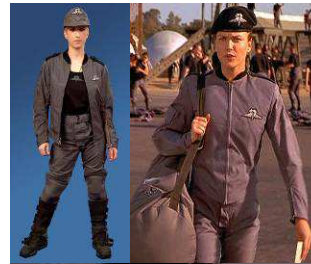

Standard UNIFORM -
 The standard all purpose uniform, standard issue is gray or black, although special forces groups are issued camo versions to suit their operating environment as well. It consists of trousers (50eb), and a jacket (70eb, 100eb for officers jacket). The trousers portion has the same number and arrangement of pockets as the American equivalent, with the addition of two pockets on the lower legs. The Jacket is lightly armored to sp: 6 and contains 2 side pockets, 2 breast, 1 back and two sleeve pockets. The uniform serves as both the battle and dress uniforms. EDF funding restrictions prevent the issue of a dress uniform, citing lack of necessity. Officers jackets are more formally styled however.



EUROPEAN DEFENSE FORCES
 Combat Gloves 60eb
 Strong rugged gloves



EUROPEAN DEFENSE FORCES
 Boots 90eb
 Strong steel toed boots, with separated metal plates in the soles, to provide protection while maintaining flexibility. Very similar to the American version



EUROPEAN DEFENSE FORCES
PILOTS UNIFORM AND HELMET 780eb
 consisting of little more than a padded flightsuit, this uniform maximizes comfort and unrestricted movement. The helmet is SP:20 and is equipped with Low-Light, Thermograph, Targeting Optics, and Anti-Dazzle



FORBES
 Motorcycle Suit (SP:6) 250eb
 Boots (SP: 10) 200EB
 Smartoggles (3o optic options, 2 Audio options) 360eb



FUCHSIART
 Cold Weather Suit 110eb
 Boots 50eb
 Gloves 40eb



GOHA
 Sports Bra 20eb
 BDU pants 35eb
 Panties 20eb



Hannibal
SLIMVEST (SP:12)
 180eb



HI-WAY
 Heavy Leather Uniform (SP:4) 450eb



FUCHSIART
 Shirt 15eb
 Pants 55eb
 Leather Jacket 200eb
 Scarf 30eb
 Panties 15eb
 Gloves 80eb



GEAR
 Arctic Oversuit 250eb
 Gloves 30eb
 Boots 65eb
 Helmet (SP:20) 120eb
 Goggles 30eb
 Web Gear 45eb
 Thigh Bags 20eb
 Kneepads (SP:8) 30eb



GREY MATTER
 Heavy leather body suit (SP:4) 200eb



ID
 Coat (SP: 8) 960eb
 Top 300eb
 Pants (SP: 8) 740eb
 Boots (SP:8) 240eb



GENEGEN
 Leather Top 330eb
 Leather Pants 450eb
 Tac gear 100eb



GRAY MATTER
 Underarmor shirt 40eb
 Pants 60eb
 High Boots 55EB
 Torso Armor (SP: 16) 200eb



KALMAN
 Overalls 40eb
 Pads (SP:5) 50eb
 Boots 50eb



KENBISHI

Protective Wear 200 eb.
This light armor, which resembles bandages, is designed to protect against both blades and projectiles. It is meant to be worn under clothes (not under a datasuit). It offers an SP 10.



KENBISHI

Francis Protective Clamshell (SP:12) this very light clamshell offers hard armor protection that can be worn comfortably under clothes for extended periods. It even covers the groin. 360eb
Gloves (SP:8) 60eb
Kneepads (SP:8) 50eb
Boots (SP:10) 200eb
Thigh Ammo Pouch 40eb



KEVTECH

Armor Weave Bodysuit (SP:4) 210 EB
Boots (SP:10) 120eb
Armor Pads 35eb apiece



KEVTECH

Kevlar Hoodie (SP:10) 560eb



KEVTECH

Combat Gloves (SP:8) 250eb



KRAFTWERKS

Tech Jumpsuit 60eb



KUNKKA

Dataweave (SP6) with shoulder, thigh, knee and elbow plates (SP:10) 725eb
Shoes (SP:10) 200eb
Gloves 50eb



MEATSWORTHY

Cold Weather Med Vest 145eb
Cold Weather Overalls 185eb
Snow Boots 150eb
Snow Goggles 50eb
Gloves 45eb
Dog Medical Carry Harness 80eb



MEXICAN MILITARY BDU'S 60eb

The mexican battle dress uniform is a simple, light, and rugged set of black or camo coveralls, it has two breast pockets, standard hip pockets, and two large thigh pockets.



MEXICAN MILITARY Dress Uniform 120eb
Includes shirt, coat, pants, belt, boots, hat, tie and gloves. This is for formal situations and officers in non-combatant roles.



MEXICAN MILITARY FLIGHT SUIT
Worn by most of the pilots in the Mexican Armed Forces. It consists of a water/air tight g-suit (300eb) and a flight helmet (SP: 20, 480eb) equipped Low Light, thermograph, Image Enhancement, Anti-Dazzle, and tele-optics.



MEXICAN MILITARY POLICE UNIFORM
The Police in Mexico are actually another branch of the military. However they are issued separate uniforms to help ease public relations and confusion stemming from duty jurisdiction. The Mexican police uniform consists of a thickened

Armourweave t-shirt (same material datafilm is made from, without the interface capabilities SP:8 200eb) with optional shoulderpads (SP: 12 25eb), and a pair of black or olive BDU style pants (30eb). For more hazardous areas or assignments, an armored vest is worn as well (SP:14 180eb) in either olive or black for SWAT duties. A pair of combat boots (50eb), a gunbelt (thigh holster, pouch for sidearm ammo, pouch for handcuffs, pouch for stripwire binders, pouch for mace, pouch for taser, loop for baton, 60eb), kneepads (SP:10 15eb), Fingerless padded gloves (protect knuckles and back of hand 10eb) and a beret (8eb) complete the uniform, though a helmet (the same as issued to soldiers) may be worn instead of the beret.



MILITECH DOG TAGS- personal means of Identification, no longer metal, these are made of highly durable transparent smart plastic which stores all the soldiers' relevant medical data readable in any computer with a bar code reader. Also issued is a Military I.D. card, which also serves as a debit card.



MILITECH Crye Combat Shirt and Pants
The standard battle dress uniform for militech troops. Worn under the armor, and utilizing Militechs Multicam camouflage, (a camouflage so effective in any environment it eliminates the need for separate jungle, woodlands, or desert camo) the main torso of the shirt (120eb) is a highly breathable but water-resistant under armor to help cool the soldier and keep him dry. The pants (130eb) have adjustable and flexible knee/shin pads woven in (SP:8). Complete the suit has 2 large thigh pockets, 2 buttock pockets, and 2 pockets on the sleeves.



MILITECH Security BDUS (pants and jacket) 40eb
Militech Light Vest (SP:10) 250EB



MILITECH/UNITED STATES MILITARY Flight Suit 875eb
Worn by most of the pilots in the United States Military. It consists of a water/air tight g-suit, flexible torso and shoulder plates (kevlar wrapped steel plates woven into a flexible harness SP: 15 torso / SP: 10 shoulder) and a state of the art flight helmet (SP: 20, 2465eb) equipped with the most state of the art technology available, including Low Light, thermograph, Image Enhancement, Anti-Dazzle, and tele-optics. The helmet also features a small hatch on the back that allows full cyber interface. For hands on action the helmet also comes with a flip down targeting scope and full visor.



MILITECH

**Advanced Flight Helmet
1965eb**

Militech Pilots wear the same Flight suit as the US Armed Forces. The only difference comes from Militechs brand new Flight Helmet, a superior version to the one they supply to the US. Although still in testing the new helmet features slightly better protection (SP:22), and even more optic options, Low Light, Thermograph, UV, Image Enhancement, Anti-Dazzle, Times Square Marquee, Tele-Optics, Smartlink to Weapons, Surveillance, and Threat System (the pilot jacks into the helmet, which is then connected to the aircraft, this allows a buffer between the pilot and the interface in case of electronic attack of feedback), and advanced communications unit. The helmet also features a small hatch on the back that allows full cyber interface.



MILITECH

**Arctic Survival Gear
200eb**

US Military issue as well as civilian sales. For use in cold weather situations, this suit provides maximum warmth while remaining lightweight and flexible. The arctic survival gear provides no armor, but is baggy enough to wear over the standard armor, and provides flaps for easy access to the web gear worn underneath. It also features a hood and a white back pack cover to maximize stealth in the snow.



Militech/ICMF

**Second South Am Style
BDU's 100eb**

These have dual pockets (side zippered) on each arm, normal pockets on the pants, a large pocket on each thigh, a large pocket on each calf, and buttock pockets. The ring around the neck is actually an extending filter/seal, that draws up like a turtleneck, which also works as a seal against rain and cold, it is lightly armored to protect against garrote attacks (SP:8).

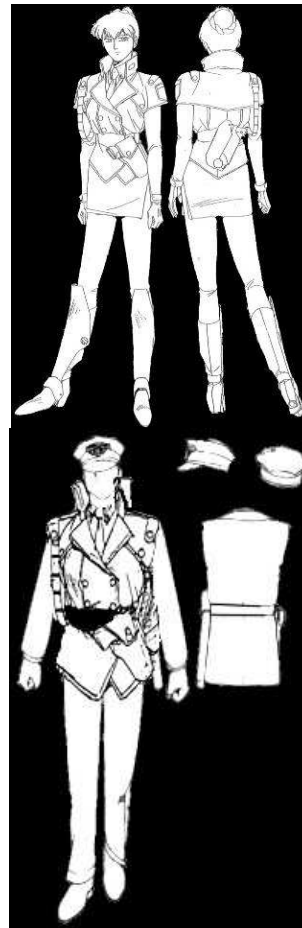

MOEBIUS

**Police Dress Uniform
250eb**

For ceremonial purposes, each police officer is also issued a dress uniform. The dress uniforms are just about the same as they always have been, A black jacket, hat and slacks, with a skirt for women, and white gloves, Along with whatever additional decorations an officer might have earned.



NEOKRON

**SECURITY UNIFORM
300 EB**

(This is the same uniform worn by Nakajimo Security, the vest and boots are armored to SP:12)



**NEO-SOVIET MILITARY
Dog Tags 10EB**

personal means of Identification, no longer metal, these are made of highly durable transparent smart plastic which stores all the soldiers relevant medical data readable in any computer with a bar code reader. Note that Russian dog-tags aren't at all similar to US ones – they aren't worn in pairs, just a single one. Only the surname and ID number of the wearer is engraved on that, pre-cut to allow breaking it into half (one half to be left with body, the other taken as a proof of soldier's death). Also, Russian troops carry these on their necks by the means of soft plastic fibbon, instead of a chain.



NEO-SOVIET MILITARY Winter And Summer Wear Bdu's
The standard battle dress uniform, Consisting of a jacket (50eb) and pants (65eb), cammo patterns will vary depending on duty. Feature sown on kneepads and Elbow pads (SP:9), and detachable shoulder pads (SP:8, 20eb). The jacket has 4 pockets, the pants have 2 normal pockets, 2 thigh pockets, and 2 buttock pockets. The winter uniform includes matching camo parka (50eb).



NEO-SOVIET MILITARY Maskhalat 10eb
Loose coverall in a specific camo, meant to be worn over the BDU and webbing (there are openings to allow you reaching your gear). These do have limited durability, but Russian Army has immeasurable amounts of them and can usually deliver you new one every time you need it – either because the previous one has fallen apart, or because you're going to fight in different terrain than before.



NEO-SOVIET MILITARY Dress Uniform
includes shirt (15eb), long coat (90eb), pants (40eb), belt (20eb), boots (60eb), hat (20eb), tie (5eb) and gloves (20eb). This is for formal situations and officers in non-combatant roles.



NEO-SOVIET MILITARY Combat Gloves 45eb
Strong Rugged Gloves



NEO-SOVIET MILITARY Boots 40eb
Strong steel toed boots, with separated metal plates in the soles, to provide protection while maintaining flexibility.



NEO-SOVIET MILITARY LIGHT FLIGHT SUIT
Worn by most of the pilots in the Russian Armed Forces. It consists of a water/air tight g-suit (260eb), armored shoulder pads (SP:15, 120eb) and a flight helmet (SP: 20, 1670eb) equipped Low Light, thermograph, Image Enhancement, Anti-Dazzle, and tele-optics.



NEO-SOVIET MILITARY Arctic Survival Gear 200eb

For use in cold weather situations, this suit provides maximum warmth while remaining lightweight and flexible. The arctic survival gear provides no armor, but is baggy enough to wear over the standard armor, and provides flaps for easy access to the web gear worn underneath. It also features a hood and a white back pack cover to maximize stealth in the snow.



PERUVIAN UNIFORM-
Being heavily reliant on the Shining Path, as well as wanting to recruit as many impressionable people as possible, the Peruvian uniform supplied by China is the most official looking of those used by SAA forces. Modern BDU's (25eb), knee and elbow pads (SP:8, 20eb) standard webbing, and modern customizable body armor vests (SP:18, 200eb) and helmets (SP:20, 80eb). The Peruvians like to use children in their recruitment campaigns, both to inspire other children (12 and above, male or female) to join, and to minimize the danger by imprinting the idea that the military is safe enough for children.



POSEIDON

Leather and Kevlar Jacket (SP: 10 EV-0) 200eb
Underarmor Thermals 50eb
Sebuoro Holsters 40eb
BDU pants 35eb



REDZONE

Shirt 40eb
Pants 45eb
Tactical Vest (SP: 18) 760eb
Gunbelt 50eb
Tactical Belt 80eb
Boots 160eb
Helmet (SP:25, 2 cyberoptic options + anti-dazzle, 2 cyberaudio options, built in radio) 920eb



SENSATION

Datafilm 2000eb
Helmet (SP:12) 200eb
Shoes 40eb



SHIROW STUDIOS
Neo-Sov style BDUs 50eb

Shirt 40eb
Hat 20eb
Boots 60eb



RASPER

Overalls 30eb
Magnetic boots 150eb



SHIROW STUDIOS

Coveralls 120eb
Shoes 80eb
Bicycle Helmet (SP:6) 40eb



RYU'S FORM

Pants 30eb
Jacket 40eb
Steel Toed boots 50eb

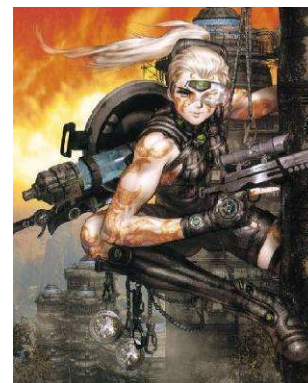

SHIROW

shorts 30eb
vest 25eb
boots 40eb
gloves 20eb
Gargoyle visor with Times Square Marquee, low light, and image enhancement, 225eb



SLIPGATE

Advanced Muscular Augmentation Exo-Suit (SP:10, +6 to BOD/MA) Sensors in the suit read muscle twitches, and transfer that signal to the artificial muscle fibers of the suit, the suit has no effect on cybernetic limbs. 23,000eb



RED FACTION

Top 20eb
Pants 30eb
Boots (SP: 14) 420eb
Short Gauntlet (SP:10) 200eb
Long Gauntlet 280eb



SLIPGATE
 Motorcycle Suit (SP:8) 250eb
 Motorcycle Helmet (SP:14) 130eb
 Gloves 35eb
 Boots 40eb



SUGAI
 Hazardous Environment Suit (680eb) (This suit not only protects against radiation, gas, and other contaminants, but is equipped with a 2 hour air supply, oxygen scrubber filter, Waste processor and on board computer and detectors for radiation, airborne contaminants both biological and chemical.)



TEKKA
 Dataweave Bodysuit (SP:8) 500eb
 Dataweave Gloves (SP:8) 150eb
 Boots 100eb



URBANTECH
 Assassin Bodywear 180eb



SMUGGLER
 HI-Way style leather jacket (SP: 6, with SP:10 shoulder plate) 560eb
 Leather Pants (SP:6) 300eb
 Boots (SP:8) 200eb
 Gloves 20eb



UNITED STATES MILITARY
 Dog Tags 20eb
 Personal means of Identification, no longer metal, these are made of highly durable transparent smart plastic which stores all the soldiers relevant medical data readable in any computer with a bar code reader. Also issued is a Military I.D. card, which in addition serves as a debit card.



TRONNICS
 Motorcycle Jacket and Pants (SP8) 650eb



TACTICAL SOLUTIONS
 Tactical Coveralls 70eb
 Armor Vest (SP:14) 200eb
 Boots 90eb
 Pads (SP: 10) 50eb
 Tactical gun belt 100eb.



STARCRAFTS
 Dataweave Bodysuit (SP:8) 600eb
 Shoulder Pads (SP: 14) 300eb
 Thigh Boots (SP:14) 780eb



UNITED STATES MILITARY

Winter And Summer Wear Bdu's - The standard battle dress uniform, available in a variety of cammo patterns, as well as olive drab, gray and black. This is the most commonly seen uniform in the military and serves both as combat clothing and general wear. Comes with a hat and belt (20EB each). (The BDU pants (35eb) have 2 regular front pockets + the small change pocket, 2 large leg pockets, and 2 buttock pockets + blousing straps, the jacket (30eb) has 4 pockets on the front)



T-Shirts 20eb green, brown, white, black, (for female soldiers, sports bras are also available)



Army



Marines



Navy



Air Force

UNITED STATES MILITARY

Dress Uniform includes shirt (20eb), jacket (35eb), pants (35eb), belt (20eb), shoes (40eb), hat (25eb), tie (5eb) and gloves (25eb). This is for formal situations and officers in non-combatant roles. Varies for service branch.



UNITED STATES MILITARY

Combat Gloves 35eb Strong rugged gloves



UNITED STATES MILITARY

Combat Boots 75eb Strong steel toed boots, with separated metal plates in the soles, to provide protection while maintaining flexibility.



UNITED STATES MILITARY

Load Bearing Equipment 45eb this is the military web gear, used for comfortably carrying a soldiers equipment, like the back pack it attaches directly to the soldiers armor.

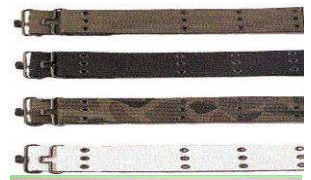

UNITED STATES MILITARY

Heavy Belt 10eb The standard military carry belt



UNITED STATES MILITARY

Leg Holster 35eb for either the Colt AMT, or the SOCOM 2020.



UNITED STATES MILITARY

Extra Shotgun Shell/25mm Grenade Pouch 45eb Carries an additional 20 12 gauge shells or 25mm grenades, allowing the soldier to perfectly tailor specialty loads for any situation, or carry enough spare ammo to re-supply a whole team whole team.



**UNITED STATES
MILITARY**

Map Pouch 50eb

Stores maps,
notepads, and other
documents.

Waterproof with easy
access pouches for
additional equipment
such as writing
utensils, spare
notepads, photos, etc...



VOVAN

Shirt 45eb

Pants 50eb

Gloves 40eb

**Tac Gear W/ Chest and
Shoulder Armor (SP:10)
300eb**

Helmet (SP:18) 80eb



WESKER

Jacket 230eb

Pants 200eb



URBANTECH

**TAC JACKETS for men
and women 150eb**



WALLIN

**Tactical Vest (SP:16)
300eb**

BDU pants 40eb

Mask 35eb

IR goggles 150eb

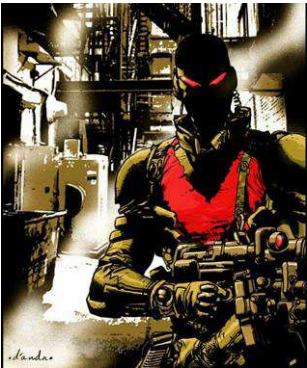

VIGILANTE

**Armored Bodysuit
(SP:8) 380eb**

**Mask with built in
cyberoptics (2 options)
180eb**

Gloves 40eb

STEALTH WEAR

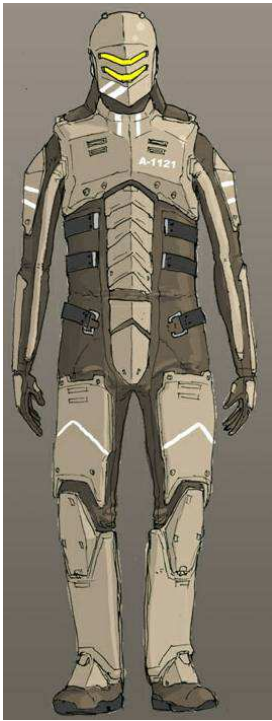

**AIA/CHILEAN MILITARY
STEALTH ARMOR
1865EB**

The Chilean military does not have funds to equip even its most elite special forces team with Therm-Optic camo, instead the opt to issue the color changing AIA stealth armor. The entire suit features a chameleon coating which allows it to switch between up to 20 pre-programmed colors and patterns at the flick of a switch. The suit itself is mildly protective (SP: 8) and has additional armor plates on the chest, arms, and legs, (SP: 10) provide a bit more protection. The suit is also thermal dampening, and the helmet (SP:20) features LL, IR, AD, and a radio.



**ARASAKA
GHAST SUIT (SP:14)
EV-0 2675**

This body suit was designed for stealth missions and is made from thermal dampening fibers that reduce the body heat signature to that of the outside temperature. While the suit moves freely and is highly flexible it becomes extremely uncomfortable after extended periods of time due to the thermal dampening properties, which do not allow body heat to escape at all. The Suit is sold with a mask, to complete the effect.



**ARASAKA
Mamba Stealth Suit
8750eb**

Used by Arasaka Special Forces when Stealth is of the utmost importance, this is Arasaka upgraded therm-optic camouflage. The therm-optic skin is woven into the same material Datafilm is made from, only 10 times thicker (provides an SP:12 rating). In addition the suit has built in pouches on each leg that can serve as a holster for a side-arm or storage for equipment, and a bandolier with a therm-optic camouflage coated knife and sheath or other gear. The finale to this suit is the helmet, which with the visor down features a full VRI interface tied in to the helmets internal radio, laser comm, low light, radar, targeting scope, thermograph, tele-optics, and image enhancement. In case the helmet electronics go down, or something obscures the sensors, the visor can be flipped up allowing the trooper normal vision. These suits are well guarded, and fetch obscene amounts on the black market.



**ARASAKA
SMGS SNEAK SUIT
18,000eb**

In addition to providing therm-optic camo and thermal dampening, the MGS Sneak Suit also boosts the wearers strength (+2 BOD, does not effect cyberlimbs) and provides light armor (SP:12). This MGS is issued only to the highest level operatives, and with its hefty price tag, only the most dedicated professional can afford it on his own. This is Arasaka's ultra-deluxe stealth suit, utilizing the best advancements in their technology. The suit comes with its own thermoptic capable helmet (SP: 18), able to equip 5 Optic options and 4 audio options. The suit comes with its own webbing and holding, also Therm-Optic camouflage equipped.



ARASAKA

Reactivewear Bodysuit 1140eb

(The wrist control sends a small electric charge into the suit, causing it to change color. Primary colors and black, gray, brown and white come, but you can by an upgrade that allows any color variation to be programmed for 300eb.)

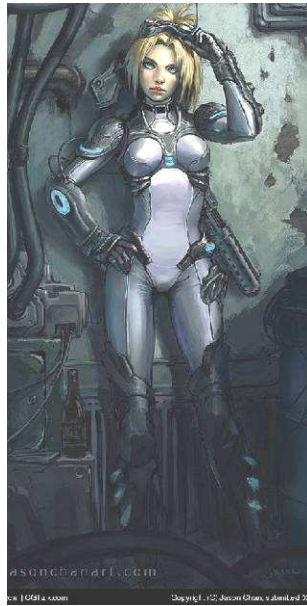

ARASAKA

Shinobi bodysuit SP:4 300eb

(This suit lowers heat signature to that of a small animal when worn)



ARASAKA

Thermasilk Stealth Combat Suit SP:10 1350EB

This suit eliminates body heat all together, the outer skin of the suit reflects room temperature at all times, the helmet is equipped with Low Light, Anti Dazzle, and Thermograph.



ARASAKA/UNITED STATES MILITARY

Therm-Optic Camouflage 6800eb
Used by Special Forces when Stealth is of the utmost importance, while wearing this armor a soldier is virtually invisible to visual detection. Unfortunately due to the nature of the suit, very little equipment may be carried while wearing it and still be able to effectively utilize its therm-optic capabilities. (Torso SP: 10 rating)



AZTECH/MEXICAN MILITARY

Therm-Optic Camouflage 4600eb
The Mexican equivalent of Ghost Suit, a little bulkier (EV-2), but with a more streamlined helmet (SP: 18 torso, SP: 15 boots and gauntlets, SP: 10 thigh, shoulder, knee, and elbow pads, SP:15 helmet and facemask,) Mexican metals actually introduced some accessories as well, including gas filtering armored facemask, a GPS enabled gauntlet mounted micro-computer, and a shoulder mounted A/V recorder. The Therm-Optic system is equivalent to Chinas, just a step behind the US, EDF, and Russian suits.



ARASAKA

Seer Poncho 1050eb
The precursor to it all, the Arasaka Therm-Optic Camo Poncho was the original therm-optic camouflage gear, and is still popular today due to its lower cost and versatility. It is worn over clothes and most armors, but the down side is that it leave the legs, or at least the feet exposed, and the tech isn't quite as advanced as the modern suits (only provides a -2 penalty to detection as opposed to the -4).



CABAL

Full Thermal Dispersion Suit 7,950eb

IR ponchos and other such suits are great, they change your heat signature from a man to that of a small animal, or even smaller. This suit is better, it uses refrigerants and heaters, all computer controlled, to make your heat signature the exact temperature of the air around you. This means that you are completely invisible to any means of thermal detection, you give off no heat signature whatsoever.

Unfortunately it also means that no skin whatsoever can be showing, and you can carry very to no equipment. The suit has only a 30 minute power supply, which must be recharged for 5 hours after use.



CHINESE MILITARY

IR- Rain Poncho 150eb Fully protects against body heat emission, as well as adverse weather



EGRET

Dingo Psych Suit 3450eb

This suit contains an array of highly specialized speakers, and can be set to generate an incredible amount of white noise, cancelling out most any sound short of a gunshot in a 2 meter radius, audio enhancers cannot overcome this, however seismic detectors will notice the vibrations caused by the sound up to 50 meters away. The suit can be switched to Anti-Resistance mode as the speakers switch frequencies and the suit acts like a wearable version of the Arasaka Nauseator (see Chrome 2) but with the field generated in a bubble around the user. The suit can also play music at incredible volume, and it is in fact a favorite tactic to silence an area, wait for a target to boost his auditory input because he can't hear anything, then blast high frequency sound or music at the highest decibels to blow out their cyberaudio. The suit comes with a specially constructed enclosed helmet, that protects the user from the suits effects.



GOSSAR/EDF

THERM-OPTIC

CAMOUFLAGE 6400eb

Manufactured by GOSSAR INC. of France, this armor is virtually identical in function and performance to either the Militech Ghost suit. It includes an armored vest (SP: 16) armored shin guards (sp: 10) and a holster and magazine pouch for the soldiers sidearm.



HAZE

THERM-OPTIC CAMOUFLAGE 5600eb

This is a European knock of Militechs Ghost Suit supplied in limited number to Argentina's military. It includes helmet (SP: 18 torso, SP: 15 boots and gauntlets, SP: 10 thigh, shoulder, knee, and elbow pads, SP:15 helmet and facemask,) The Therm-Optic system is equivalent to Chinas, just a step behind the US, EDF, and Russian suits.



MILITECH

GHOST II THERM-OPTIC CAMOUFLAGE

Estimated 7500eb

A bit heavier armored than the version used by The United States, Militech has announced they will not sell these, even to military or government clients, until they have developed an even better version, allowing them to stay just a bit ahead of competition. Special Forces wear these suits when Stealth is of the utmost importance, and while wearing this armor a soldier is virtually invisible to visual detection. In addition to extra armor, the suit boasts comes with its own weapon holsters and equipment pouches so stealth is not lost due to being lightly armed. It also comes with a therm-optic camouflaged weapon bag, for rifles or other long weapons. Militech does sell the bag separately for 6000eb. (Torso SP: 14 rating, no encumbrance penalty).



MILITECH

**Black Ops Bodysuit
SP:4 200eb**

(This suit lowers heat signature to that of a small animal when worn)



**POSEIDON
Therm-Optic
Camouflage**

As thin as a data suit but with a completely different purpose. This suit is very similar to the Militech M95 Ghost suit but is far superior, as the wearer becomes virtually invisible when the suit is activated. The suit is very hard to detect, but a slight blur can be seen when the wearer is in motion. As long as the wearer stays still they are virtually impossible to detect. While normally detectable by certain heat imaging optics some suits can be made which reduce IR signature. No EV penalties apply and this suit is usually worn under some type of armor, which must be taken off before use. This suit offers a -6 against visual awareness when standing still and -5 when moving. Cost is 6000eb standard and 8000 with IR baffling. Available only to military. (*Ghost in the Shell*)



**ROSTOVIC/NEO-SOVIET MILITARY
Jnz-4b Therm-Optic
Camouflage 8400eb**
Taking the best of both Arasaka and Militech innovations this latest generation of Russian Therm-Optic Camouflage is perhaps the best in the world. Offering full, but flexible protection (SP: 14), and designed to work even in harsh weather conditions (most therm-optic camo will glitch in water) and thermal dampening, this suit is nearly invisible, even in driving rain



ROSTOVIC
This Russian first generation version of the Militech Ghost suit offers minimal protection (SP:5) and is a bit more visible than the modern counterpart (-3 to notice rolls instead of -4) and has a tendency to glitch (every ten minutes of use the suit fails on a roll of 1-2 out 10).

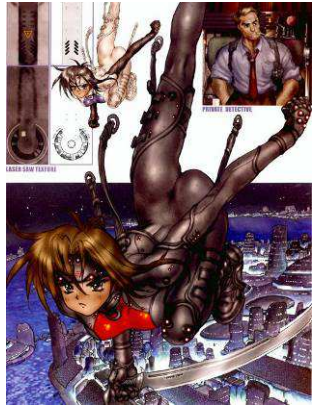

**POSEIDON
Ghostweave SP:6
2160EB**

This suit, made from the same material as datafilm, both lowers body temperature signature to that of a small animal, and can change colors ala Arasaka's Reactivewear Bodysuit.



**UNITED STATES
MILITARY
IR- Rain Poncho 180eb**
Fully protects against body heat emission, as well as adverse weather

DATAFILM

The Combat Zone stocks the largest selection of Datafilm in Night City. Regardless of whether the ACPA you are piloting is construction, security, police, or if you are just making a fashion statement. Apparently Datafilm has become so popular in the private sector, that many people who will never get anywhere near a Landmate have taken to wearing them as an alternative to body gloves, sweat suits, and sports apparel because it hugs the body so incredibly well, better than latex or spandex by far. Therefore those with the bodies love showing them off with datafilm.

DATAFILM

Or datasuit, as it is also called. This incredibly thin suit is meant to be worn under powered armor, and transmits the wearer's commands to the landmate. Datafilm has an SP of 6. It protects against acids, alkali's and other chemicals, lets sweat escape while repelling water and cushions shock. It is a fabulous invention (in the words of SHIROW himself). Apparently if the wearer is knifed it would hurt a great deal but the blade would not penetrate the datasuit. It's made if the same materials used to coat cyborg and landmate musculature. Data suits come in a variety of colors and pattern and are made by several different companies. Due to the tight fit and variations in height, weight and structure I would imagine that each datasuit is custom made for the specific wearer. You must wear a datasuit to operate a landmate. Cost varies from 200eb to 2000eb depending on manufacturer and design. The suit gives +3 to any ref action made while using a land mate. Available to public.

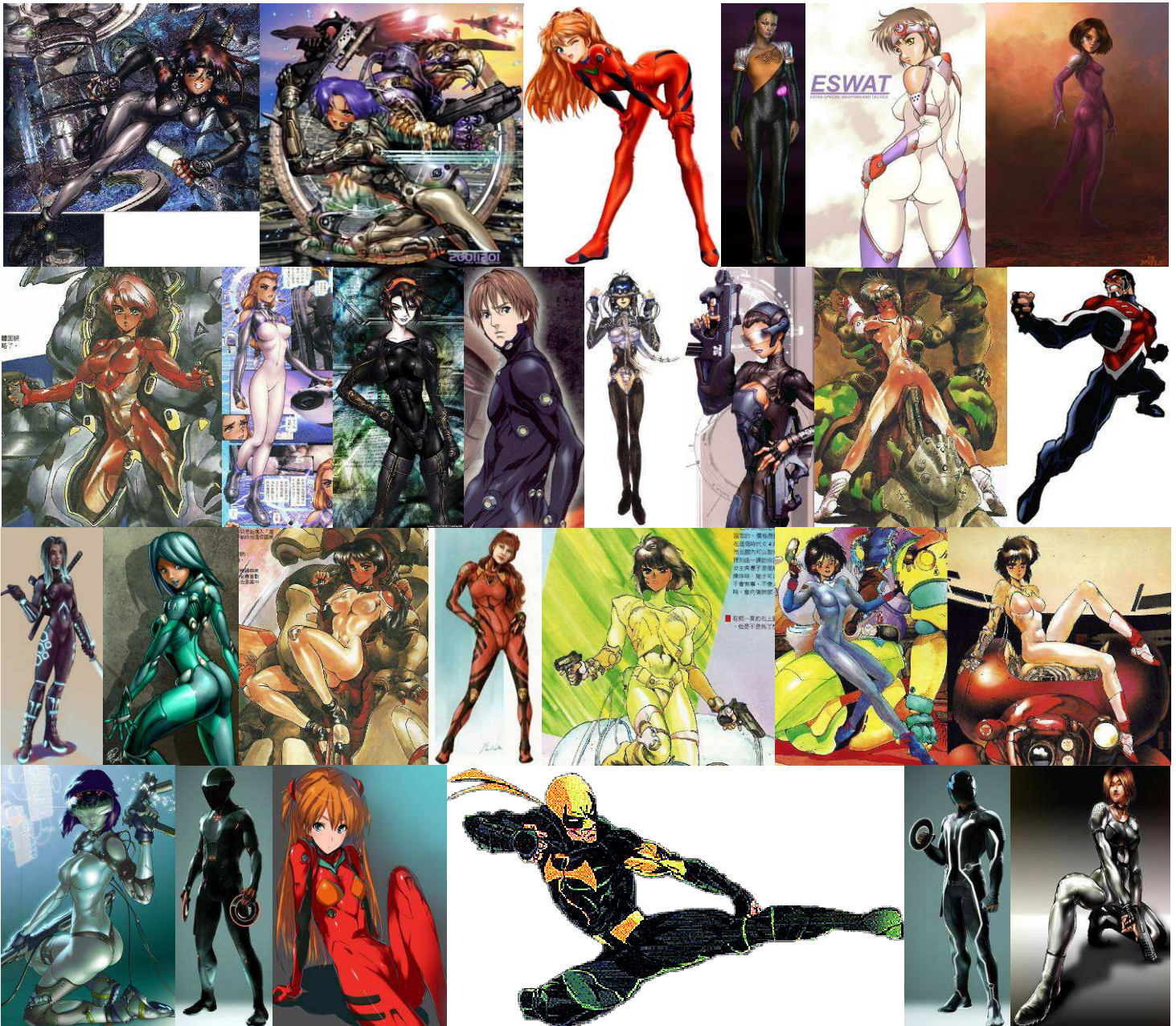

ARMOR



ARASAKA GUNNERS VEST SP: 30 EV-4 1250eb
 This armor was designed for one purpose, to be worn by personnel firing fixed weapons. Because it doesn't allow full range of motion on the arms, it isn't very popular at all. It's also very heavy, another factor that doesn't do much for its sales. Still, if it's your job to man the turret on a tank, or the door gun on an AV or chopper, it's hard to beat the protection this armor offers.



ARASAKA LYNX SP:16 EV-1 475eb
 Arasaka's attempt at recreating the Gasium K-5. It doesn't offer as much protection, and does hinder movement very slightly. But if your budget doesn't allow for Gasium, this is the next best thing.



ARASAKA ORC ARMOR 21,500eb
 A lighter, albeit bulkier version of metal gear, this slightly powered personal armor has a REF bonus of +1 and an SP of 25. Used for fast assaults into high risk situations by E-SWAT, it is specially made for maneuverability and stealth. It too utilizes the data film for transmitting the physical signals too the suit. Orc suits can monitor acoustic signatures, or A/S, giving them an awareness bonus of plus +2. The system is also designed to monitor their comrades for the sound of breaking armor, giving them a better teamwork ratio in stealth operations. The helmet is equipped with; auditory boost, low light enhancement, image enhancement, and tele-optics. The suit also boosts the BOD and MA of the user with a bonus of +4 each.



ARASAKA CV-2 VIPERSKIN LIGHT ARMOR VEST (SP: 15 350EB) provides full protection for the torso as well as shoulders, and the collar is armored to act as a gorget. This armor incorporates a unique strap design for attaching the shoulder padding, the heat dispersal pads, and various other pouches and accessories, the standard configuration consists of 4 pouches plus 2 grenade loops, though other variations are common, and back straps are present and functional for even more specialization..

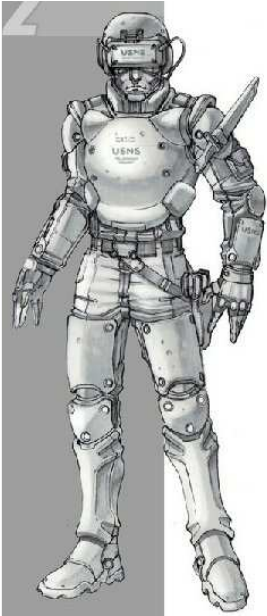

ARASAKA IAA-13 SP:14 (torso, head) SP:12 (arms, legs) EV-0 350eb
 This light armor is one of Arasaka's most popular designs, and sells well to private security forces. The helmet is fully equipped to install up to 4 cyberoptic options.



ARASAKA SUPPRESSOR (SP:30) EV-3 5476eb
 This heavy armor from Arasaka offers more protection than standard Metal Gear. The helmet is equipped with Low Light, Anti-Dazzle, UV, and a military radio communicator.



ARASAKA CV-3 Gauntlets 180eb
 Protective gauntlets (SP: 10) for the forearms, these protect from both bullet and knife, and are effective in riot situations as well as being covered in the same heat dispersal panels as the vest and pants.



ARASAKA

CV-4 Helmet 580eb

This helmet(SP: 20) features a full faceplate equipped with anti-dazzle, low light, thermoptics, Ultraviolet, Times Square, and targeting scope, the helmet also has a built in radio and lasercomm. Finally the helmet is self sealing and acts as a gasmask.

The goggles are actually high tech binoculars (treat as teleoptics with x4 range). Like the uniform and armor, the color of both helmet and faceplate varies, from standard blue and silver, to high visibility gold and red, to helmets in more stealthy colors or camo with non reflective visors for covert or field operations.



ARASAKA

Collapsible Ballistic Shield 450

At the touch of a button this shield expands from the size of a small panel to a full riot shield, protecting the user even from most small arms fire (SP:25), and the shield is transparent so you never lose sight of your target when you are taking cover.



ARASAKA YOJIMBO-7 BODY ARMOR 2890eb

Maximum protection without sacrificing comfort. Using the same material as datafilm, although thicker (SP: 10), for the flexible suit, then adding Spidersilk soft armor plates to cover all vital organs (SP: 15), Arasaka has created a very flexible, skin tight armor that not only doesn't restrict movement at all, but is almost invisible under regular clothing (A/N role of above 22 to spot under loose clothing). (When hit in any location, there is a 20% chance that the bullet will hit the datafilm cloth, missing the Spidersilk Armor pads.)



ARASAKA/MEXICAN MILITARY

LBAV-8 BODY ARMOR VEST 410eb (SP: 18)

Instead of straps, this armored vest has customizable pocket arrangements to more securely store your gear, or if one is inclined, one can simply use the pockets for thick Kevlar pad inserts (SP:20 10% chance bullets misses inserts, additional ten percent chance for every pocket used to store gear instead of armor.)

The pockets vary in size, allowing a perfectly tailored custom load out every time.



ARASAKA/MEXICAN MILITARY

Knee And Elbow Pads 45eb (SP: 8)

A bit of added protection.

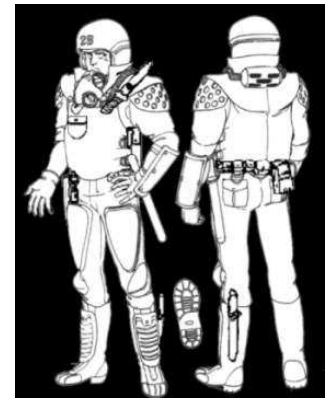

ARASAKA

Police Issue Armor Vest (SP:20, 310eb) and Helmet (SP:25, 250eb)

This armor is designed by Arasaka to be all purpose, and so Uniformed officers, Swat, and C-SWAT are all issued the same vests and helmets with minor variations in color to differentiate them. Normal uniformed duty officers wear Blue jumpsuits with white vests and helmets. SWAT officer uniforms vary in that they wear Black jumpsuits with gray vests and helmets, and C-SWAT personnel wear gray jumpsuits and blue armored vests and helmets. In addition, there are armored coverings for the forearms, shoulders, thigh's, knee's and boots (SP:10, 25eb each). As well as hard inserts for the vest (SP 5 and gives the vest an EV 1, 15eb). These addition armor plates and inserts will have the same coloration as the officers issued uniform colors depending on duty.

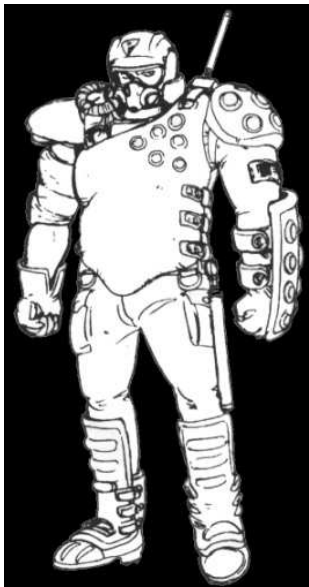

ARASAKA
Police Issue Riot Armor
 This heavy armor consists of a heavy flack vest (SP:30, EV 2, 500eb), reinforced arm gauntlets (SP:15), woven Kevlar pants (SP 18, EV 1(550eb), armored boots (SP 12, 350), a more streamlined helmet (so bottles and the like bounce off instead of smashing full force) (SP 25, 120eb), and a better gas mask/filter (235eb). This armor is very heavy, and while it offers excellent protection, it severely limits mobility. Useful only for Riots, although the bomb squad seems to have taken a shine to them too. These suits also feature a glowing blue bar with extends from the shoulder, this make the officers wearing the suit easier to spot in a crowd. The standard black jumpsuit is worn underneath.



ARASAKA
POLICE ISSUE
METAL GEAR 750EB
 This armor is used only for extremely hazardous situations. With C-SWAT getting the most out of it. It is standard metal gear (SP 25 EV 2) and makes for an intimidating sight. The jumpsuit is worn underneath, but absolutely no addition armor can be worn under the metal gear. The helmet features the basic visual package (LL, AD,) and the basic helmet radio. Please note that metal gear is to be used only in emergency situations, as its appearance has been known to cause public relations nightmares. The public doesn't like seeing its officers in metal gear, as it implies something nasty is happening, which can lead to public mistrust and or apprehension of the police.



ARASAKA
Police Issue
Datafilm 340eb
 Since the police use the landmate styled Enforcer ACPA, a datasuit must be worn underneath. This uniform is skin tight, and nothing can be worn above or beneath it (except underwear) to operate properly. The police version, its marking not withstanding is functionally exactly the same as its civilian and military versions.



ARMATECH
HV-7B1 Armor 650eb
(SP:25, EV-3,)
 For heavy weapons specialists, the ICMF makes use of the second South American War U.S. issued flack armor. It consists of heavy plate body armor with shoulder pads, and a built in gyro-stabilization mount. Heavy Kevlar skirting completes the armor, to protect the upper portion of the wearers legs and groin.

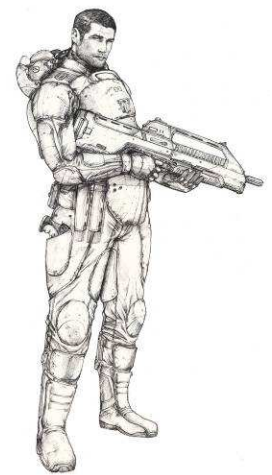

ARMATECH
Battlesuit AAW-5 510eb
(SP:20 torso and helmet) (SP:15 limbs)
 This suit, issued to U.S. special forces during the Second South American War was the precursor to modern metal gear. Unlike the metal gear of today, which most often consists of layered crabshell hard armor plates, the AAW-5 was made up of form fitting semi-rigid plates and softer Kevlar pieces all woven into a flexible bodysuit. The suit has built in adjustable holsters and gear attachment points, ad the helmet features a radio and built in anti-dazzle. ICMF forces still have plenty of these suits, which were left behind when the US pulled out of South America.



ARMATECH
HD-7 Armor 350eb
(SP:16)
 A knock off-of the popular US Military issue breastplate.



BLUE SHIELD

Concealable Armored Vest 250eb

Plain clothes

detectives, make the most use of this armor, though undercover and even informants may on occasion make use of it as well. It is a light and extremely flexible ballistic vest providing protection to the vital organs. It is rated at SP:12, though it has pockets for a hard armor inserts that boost the armor rating up to SP:18. While the plates restrict movement somewhat (EV-1) with or without them the vest is virtually invisible to the untrained eye (diff: 22 to spot) and is available in both male and female versions in either white or black.



BLUE SHIELD

Concealable Armored Undergarment 560eb

SP 12

Comfortable layered Arachne-silk over thin segments of Kevlar.



BLUE SHIELD

Concealable Hard Armor Vest

SP: 18 1050eb

This is the upgrades version of the Blue Shield Armor vest, it has molded hard armor clam shell plates attached in segments for maximum comfort and freedom of movement. It's considerably more expensive because each vest must be tailored specifically to the owners body, and adjustments will have to be made if the user gains or loses a significant amount of money (200eb). However the benefits of light weight and covert hard armor protection are more than worth the cost.



BLUE SHIELD

Scorpion Gauntlets 400eb (SP:20)

These gauntlets offer hard protection for your forearm elbow and the back of your hand, and for added defense a high powered taser is built into the gauntlet just above the wrist.



BLUE SHIELD

Cobra Gauntlets

350eb (SP:18)

Similar to the Scorpion Gauntlets, these forearm protectors contain an aerosol sprayer that can be loaded with a variety of substances, from tears gas or pepper spray, to acid, or even drugs.



CAMTECH

"Joshua" SP:20 (torso)

SP:10 (arms and legs)

EV-0 500eb

Flexible armor for personnel in a support role. It leaves a lot of important areas uncovered, but its light and doesn't restrict movement at all.



CAMTECH

Blacklite Armor

720eb (SP:27)(EV:-1)

A very durable suit of Metal Gear style armor, head to toe protection that outperforms the competition.



CHINESE MILITARY

Torso Armor 310eb

(SP: 18)

This armor is little more than a Kevlar vest, flexible enough to be comfortable while capable of stopping most small arms fire. The vest is equipped with straps and pouches for securing any gear the soldier might carry.



**CHINESE MILITARY
Neck Armor 8eb
(SP: 15)**

This is basically a heavy Kevlar scarf worn on the shoulders. It doesn't protect from strangulation, though it does protect from small arms fire, and allows the gasmask to rest comfortably from it when not being worn.



**CHINESE MILITARY
Heavy Gunners Armor
600eb (SP: 25)**

Equivalent in function to the American version but much heavier and offering of more protection. The front portion consists of heavy plate armor with a large collar and shoulder pads.

Unfortunately the armor only has a light, flexible Kevlar pad (SP:12) in the back, definitely a weak spot, but since the Chinese military commanders look down on retreat, they don't worry about it much.



**CHINESE MILITARY
Helmet 250eb- (SP: 20)**

A Kevlar composite helmet with a short range radio installed, with the microphone built into the gas mask and the speakers built into the inside of the helmet. Included with the helmet are Smart Goggles equipped with Low-Light, Thermograph, and Anti-Dazzle. The gas mask is also standard issue, it is attached to the filter unit mounted on the shoulder, or to an independent 20 minute air supply worn on the right hip. The soldier may switch between the two options as need arises. The gas mask also provides SP: 10 facial armor.



**CHINESE MILITARY
RED BEAR ARMOR**

Preferred by special forces over the bulky standard armor, this light weight composite plate armor consists of chest plate (SP: 16, 200eb) shoulder arm and shin plates (SP: 12, 10eb apiece). It allows the soldier wearing it to move faster, and creates less of a profile than the heavier standard armor.

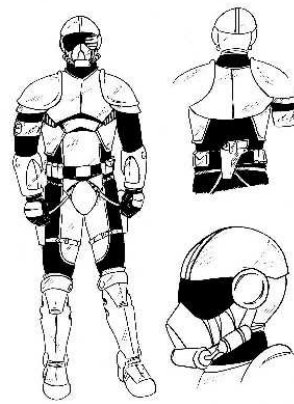

**CHINESE MILITARY
Metal Gear 510eb
(SP: 20) (EV: 2)**

Absolutely no frills is the best description for this Chinese armor.

The hard plates are worn over a soft ballistic weave (SP: 6) and the helmet comes equipped with Infra red, thermograph, and anti dazzle, as well as a short range radio. The suit is extremely light weight, mostly due to its sparse (for metal gear) protection, and can be worn comfortably longer than it's US or EDF counterparts.



**COBRATECH
VYPER SP:18 (torso,
arms, legs) SP:20
(head) EV-2 350eb
Light rigid combat
armor, very popular
with European and
Asian police forces.**



**COLUMBIAN
Heavy Armor**

This heavy armor is similar to the standard Columbian armor, though much more effective. It consists of a heavier vest (SP:20, 450eb) an armored shoulder pad (SP:15, 20eb), and leg and arm pads (SP: 12, 25eb each).



**DREAMER
Fox Armor Jacket
500eb (SP:14)**

A stylish, sleek, and lightweight leather and kevlar jacket, popular with motorcyclists and nomads because it offers as much protection from the road as it does from combat.



DREAMER
Thigh/Knee/Shin Armor
300eb (SP:14)
Molded Kevlar and steel, available in a range of styles. Similar elbow/forearm armor is also available for 250eb.



DREAMER
Armored Boots
375eb (SP:14)
Armored boots in a variety of styles from the company that seems to make their products for both motorcycle riders and combat pros.



ENTRON
Media Helmet 1250eb (SP:20)
This helmet was designed specifically for war war correspondents and other photographers or reporters in high conflict areas. It has 2 cameras that can record simultaneously, each equipped with tele-optics, low-light, UV, and image enhancement. A headlamp capable of normal or UV light emission as well as an audio recorder/radio transmitter with satellite link are also built into the helmet. The visor has the same options the cameras do, as well as times square marquee that will display the images/video being recorded. The cameras each feed in to a separate easily changed recording chips (6hr's each), and the onboard microcomputer allows for editing on the fly. Audio will record to either chip, neither, or both.



EUROPEAN DEFENSE FORCE
Military Issue Torso Armor 420eb (SP: 20)
The flexible, highly durable armored vest used by all EDF forces. Very light but offers no arm or groin protection. For added mobility the armor is modular, with shoulder pads, breastplate and mid-section wrap, and back plate.



EUROPEAN DEFENSE FORCE
Military Issue Helmet 250eb (SP: 20)
A very lightweight combat helmet, it is even semi flexible. A short range radio is installed in the helmet, with the microphone built into the chin strap and the speakers built into the inside of the helmet. A flip down visor is standard equipped with AD, IR, and LL.



EUROPEAN DEFENSE FORCE
Military Issue Neck Armor 50eb (SP: 12)
heavier than the U.S. counterpart, but offering better protection, and protects the entire neck, not just the front.

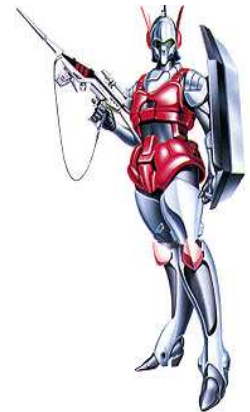

EUROPEAN DEFENSE FORCE
Military Issue Metal Gear 890eb (sp: 25) (ev: 3)
Used solely for guarding highly secure areas and for extremely heavy combat situations, as it is too heavy for prolonged wear. The armors appearance varies depending on branch of service. Customization is common, however most officers suits are more elaborately customized than others. Suits will also be outfitted according to their use, such as the Navy's scuba armor, and the arctic and desert survival armor. There is even space armor for use by the Air Force. All suits are equipped with a cooling/heating system with a 3 hour battery and 3 hour air supply. The styling of the armor reflects European ego.



EUROPEAN DEFENSE FORCE

H.A.S.S.A.R. Armor 1200EB

The European heavy combat armor. It is basically metal gear with a few extras.. It provides SP:25 armor, comes with a helmet and removable face mask that functions as a gas mask with a built in person radio, therm optics, anti dazzle, Times square option and low light. the jumpsuit worn underneath is armored to SP: 6 and if the full version is worn, including powered leg units (allowing the soldier to make leaps up 15 feet and 10 feet high) the soldier wearing this is almost unstoppable.

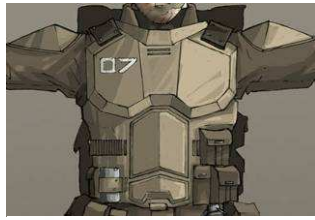

FAMAST

GR-4 Body Armor Vest 400eb (SP: 18)

Very similar in design and function to the American standard issue Body Armor. The GR-4 armor vest is a soft armor vest with Hard-shell plates attached directly protecting the chest, shoulders, spine, and abdomen. The adjusting straps serve as an attachment point for additional equipment pouches, ammo, gear, or holsters. Knee And Shoulder Pads- (SP: 8, 45eb) Affix directly to the BDU's via special clasps. Additional Armor Add-Ons- for increased protection under heavy fire, a soldier may opt to wear the issued hard armor plates protecting the thighs and lower legs, as well as gauntlets protecting the forearm and elbows.



FAMAST

Helmet 200eb (SP: 20) Fully enclosed with an armored faceplate, the visor is equipped with LL, Thermograph, and tele-optics and a built in short range radio completes the helmet.



FAMAST

GR-8 21,350EB (SP: 20) (EV: -1) (STR: +2) (MA+1)

A very advanced and highly sought after piece of equipment, the Argentinean version of Advanced Metal gear is easily comparable to Arasaka's ORC suit. Not quite as highly armored, but much less bulky. The GR-8 is so impressive, that Mossad has placed a large order for them. In addition to boosting strength and speed, the suit's helmet is equipped with radio/laser comm, Level Damper, Thermograph, Low-Light, Image Enhancement, Times Square Marquee, Tele-Optics and Anti-Dazzle.

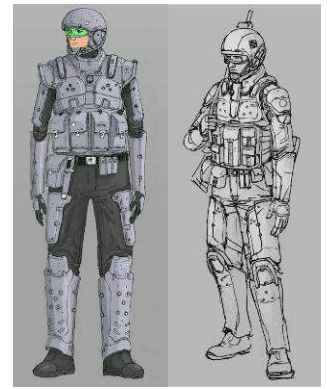

GERMANICS

PBA-5 Body Armor 1475eb (SP: 18 EV-1)

The PBA-5 is actually a complete armor system, that is worn in stages depending on duty and threat. It all begins with this vest. A hard shell torso plate that extends halfway down the back and chest is attached to a light form fitting armorweave (SP:8) which connect the lobster shell stomach, side and lower back plates. The design of these additional plates allow for a myriad of pouches, ammo, and other equipment to be attached for a very customized loadout tailored to any situation. The main reason this armor was replaced was due to its high cost, which was twice that of the modern system and its encumbrance, for a military force the size of the EDF, it simply wasn't cost prohibitive, it also took a bit longer to put on and take off. But for a smaller army, even one the size of Chile's, it was more than worthwhile



EZ-TAC

FTO-5 Vest 80eb (SP:20, EV: -1)

A very inexpensive armor vest made of semi-rid plates over kevlar, particularly for its protection rating.



GERMANICS
PBA-5 Additional Armor
 25eb each (SP: 12)
 Additional armor plates, worn at the thighs, and shoulders as well as gauntlets and shin guards, complete the basic armor ensemble. These replace the need for a separate suit of metal gear, as a soldier can armor himself up to equivalent protection. Sadly, there is no groin protection in any variation, another reason the system was abandoned by the EDF.



GERMANICS
PBA-5 Helmet 500eb
 (SP: 20)
 Fully enclosed with an optional armored faceplate/gasmask, the drop down visor is equipped with LL, Thermograph, and tele-optics and a built in short range radio completes the helmet.



GUILTY SPARK
Dataweave Metal Gear
 (SP:25) 6450EB
 (Segments of ceramic plates directly bonded to Dataweave, makes for a perfectly fitting armored shell segmented for maximum maneuverability and agility.)



JIN
TANGIER BODY ARMOR (SP: 16 torso, legs, arms) EV-1 720eb
 Less protection than Metal Gear, but infinitely more comfortable.



JIN
BODYGUARDIAN Suit
 (SP:10) 1230eb
 Helmet (sp:20 w/ 4cyberoptic options and 2 cyberaudio options) 780eb
 Essentially just a triple layered Datafilm with a little extra padding around the vital areas.



MALORIAN
White Knight Armor
 SP:20 EV-0 13500eb
 The market is very slim for these suits, mostly due to price, which must be hand made and custom fitted to each individual. While they seem a bit ridiculous in their advertisements, Malorian guarantees they are 100% combat effective. The original design was created when Kerry Eurodyne contacted Malour about outfitting his bodyguards with a more aesthetically pleasing version of Metal Gear.

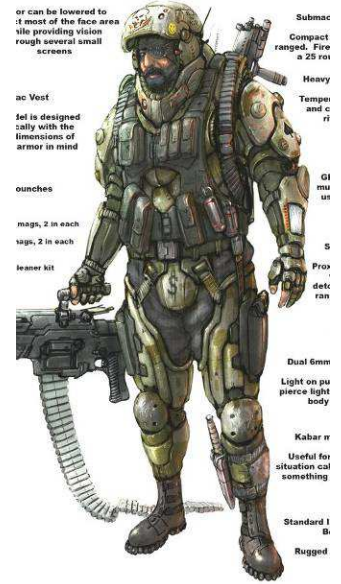

MARS
Mercenary AHA-3
 16,250eb
 (SP:25) (EV:1) (STR:+3)
 An early and slightly inferior equivalent of HAL-05 metal gear plus armor is very rugged, and stands up well to rough wear and abuse. It gives the wearer a slight boost to strength, and allows him to stand up to even the most brutal opposition. Made by an Australian company and rumored to have been supplied by the EDF, these are most often used by ICMF special forces type groups, or in cases of heavy defense positions. The helmet features built in radio, Thermograph, Low-Light, Anti-Dazzle, Smart link, and Level Dampener. The suit also features several attachment points for a large variety of equipment pouches, ammunition storage, and weapon holsters.

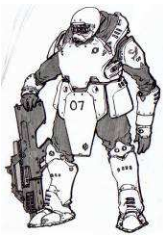

MEXICAN METALS
ACHAS-02 19,350eb
(SP:30) (EV:3) (STR:+4)
 This suit of metal gear plus is the heaviest in standard use of any military in the world. It is not as agile as or as strong as some of its counterparts in the EEC, Russian, or American militaries, but its protection is incomparable. The suit provides the wearer with a strength boost which helps alleviate the stress of the weight of the suit itself, though its size still adds greatly to the encumbrance of the armor. The cloth portions of the armor are actually thick Armorweave (SP: 8) draped over a strength boosting frame. Just shy of hardsuit classification, this suit features a 30 minute independent air-supply, a cooling system made necessary by Mexican climate, and the helmet is equipped with IR, Anti Dazzle, Low-Light, audio dampers, and a military radio/laser communicator. Additional accessories include a gyro-stabilization harness and back mounted ammo hopper (200 rounds) for heavy gunner duty, and disposable self inflating flotation units for naval duty. Mexican Metals is hard at work on an advanced model that reduces the encumbrance by over half while still retaining full protection and strength boost.



MESSER
Stagg Armor
500eb
 Sold as a set, this armor includes a hard armor clamshell breast plate with high collar and shoulder pads, kneepads, gauntlets, elbow pads, groin and abdomen protector, armored boots, and a helmet (all SP:20).



MILITECH
Commando US-SCAB2
1055eb
SP:16 (torso) SP:10
(legs, arms & groin)
EV:0
 This version of the Standard Combat Armor produced for the US Military is specifically designed for special forces. So far only the Army and Air Force special forces have officially adopted it.



MILITECH
Commando US-SCAB5
1055eb
SP:16 (torso) SP:10
(legs, arms & groin)
EV:0
 Since the SEALS wouldn't go for the original Commando armor, Militech took their suggestions and went back to the drawing board. This is what they came up with and is currently being tested by selected SEAL teams serving in Africa and Southeast Asia.



MILITECH
Blastmax Armor
1420eb (SP:35, EV:-5)
Bomb Disposal Armor,
 this armor has the highest protection rating you can get on personal armor without involving a powered frame. The helmet is equipped with Tight Beam Laser Communicator, Flashlight, Tele-optics, Therm-optics, Image Enhancement, and Micro-optics.



MILITECH
HACA-12 SP:25 (torso,
head) SP:14 (legs,
arms, groin) EV-2
975eb
 This heavy armor is a budget alternative to metal gear for heavy assault situations. It is customizable upon request and offers fantastic protection for most of the body.



MILITECH
M-9 CRYE Body Armor
550eb (SP: 15)
 This vest is slightly flexible and protects the torso of the wearer from most small arms fire, it is also highly modifiable due to the straps running across it, allowing it's loadout to be customized to the wearers exact needs. It features optional shoulder pads, optional belt brace for heavy loads, and additional armor plates (SP:8 EV-2) can be added instead of equipment pouches.



MILITECH

Groin Armor 80eb (SP: 10)

Protects the soldiers groin, while somewhat uncomfortable, this is perhaps the most popular piece of armor among the soldiers, after all it protects the soldiers favorite piece of equipment.



MILITECH

Neck Armor 30eb (SP: 10)

An armor plate gorget that protects the wearers throat, won't do much against most bullets, but will some protection is better than none, and will prevent garrote attacks effectively.



MILITECH

CRYE Ballistic Helmet 850eb (SP: 18)

The helmet itself is a simple, but highly sloped bucket. Militech has added a detachable high resolution video/audio recorder w/ 2 hours recording time, a detachable short range radio, and removable smart-optic shades with Smartlink, Anti-dazzle, UV, and

Tele-optics. In addition to the smart-optic shades, the helmet has a flip down monacle attached directly to the camera equipped with Times Square, Image Enhancement, Thermograph, Tele-optics and GPS (allowing the soldier to actually utilize 2 different optic systems at once. This monacle is always in direct connection with the RTO, whose pack receives and transmits GPS locations, messages from base, Satellite imagery (allowing the soldier to have a top down view of his current location), or audio/vid from the rest of the team (allowing the monacle to display what his teammates are seeing). The U.S. Military is already looking to implement the features of this system into their own helmets. The helmet also features a removable flashlight, capable of emitting regular, Ultraviolet light or a laser, and a removable armored muzzle (SP:10) to protect the wearers face and acts as a gas mask, sealing around the smart-optic shades and the helmet. (The latest version has smaller non-detachable light and camera and is more streamlined)



MILITECH

M-1 Armored Vest 280eb (SP:15)

First issued to American troops during the Second South American War, this is still the most commonly used and widely distributed personal armor among the ICMF soldiers. In addition to the straps to affix the load bearing equipment, this armor also has numerous small straps and loops for storing individual rounds of 5.56 mm ammunition (40 rounds) or other equipment. It also features removable flexible armored shoulder pads (SP:8)



MILITECH

M-2 Torso Armor 350eb (SP: 20) (EV-1)

Primarily used in conjunction with the 2nd South Am War U.S. style BDU's supplied by Militech, this plated body armor is very close in design and function to the M-3 armor currently used by United States forces. It was introduced late in the 2nd South Am conflict and is a common sight with ICMF forces.

Unfortunately the armor can get a bit hot and uncomfortable, and most soldiers prefer the softer M-1 armor vests.



MILITECH

M-1k Knee Pads 60eb (SP: 8)

Protects the wearers knees.



MILITECH

M-1H Helmet 460eb (SP: 18) Again, like the M-1 armor, this helmet was issued to U.S. forces during the Second South American War, and is still the most common headgear in use among ICMF personnel. It features attachment points for any standard (1995-2015) era night vision goggles, built in radio, and flip down visor with anti-dazzle coating and an inner flip down monacle with times square marquee.



MILITECH

SPARRA (SP:22 EV-1) 1230eb

A slightly lighter, more flexible version of Metal Gear.



MILITECH
Metal Gear Mrk-I 600eb
(SP:25) (EV-3)
 The very first suit of metal gear ever produced, and issued in large numbers to United States Troops during the Second South American War. Large, bulky, and hot, it nevertheless afforded excellent protection. It was particularly effective in the Andes Mountains and in Operation: Blind Faith. This armor is still widely in use by the ICMF as the surplus for the suit is immense, plus it is just one more symbol of the abandonment. The helmet is equipped with a radio and a flip down visor with Ultra-Violet, and anti-dazzle.

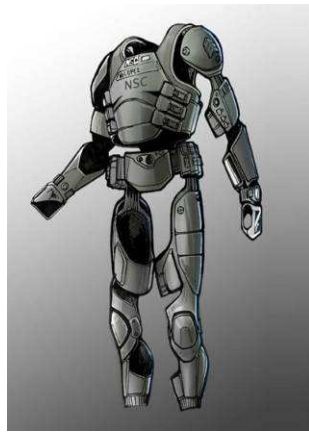

MILITECH
ARM-7 Combat Exosuit-2100eb (sp: 15) (ev: 0)
 The ARM-7 combat exosuit uses the same Strength Enhancing power frame as the HAL-O5 suit. By eliminating the heavier armor in favor of a thinner shell, and not bothering to completely enclose the wearer, the ARM-7 suit can be worn over its users normal clothes and provide him with an even greater strength boost than the HAL-05 armor (+6) due to the suit having less base weight. This latest breed of exoskeleton is a far cry from the old bulky models of the past. And while the wearer may not be as protected as the heavier HALO-5 suit, his strength boost more than makes up for it.

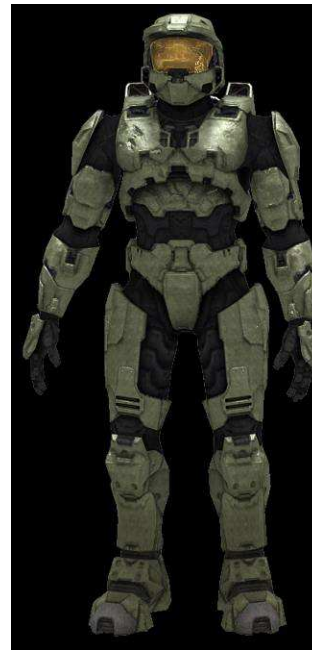

MILITECH
HAL-05 Metal Gear Plus 24,000eb
(SP:25) (EV:2) (STR:+5)
 Like most things in the U.S. military, the US standard issue Metal Gear is much more utilitarian and functional than it's European counterpart. The same suit is worn by all branches of the U.S. military, so any additional options are easy to install, such as thrust units for E.V. duty or swimmer options for underwater operations. As standard the suit is air tight, able to withstand depths of up to 500 feet, and is equipped with its own cooling/heating system with 4 hour battery. The helmet features full optics suite with (IR, Thermograph, Targeting Scope, Low Light, and Anti-Dazzle).



NEO-SOVIET MILITARY
Body Armor Vest 280eb
(SP: 15)
 Has straps for directly attaching web gear or additional armor. Additional armor includes Upper Torso Hard Set (SP:8), side attached thigh plates (SP:8) and zipper attached groin protection extension (SP:10)

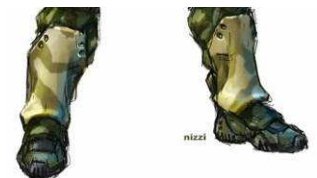

NEO-SOVIET MILITARY
Shin Guard 30eb (SP: 8)
 Protects the wearers legs, not very comfortable, but every bit of protection helps.



NEO-SOVIET MILITARY Gauntlets 20eb (SP: 8)
Protects the wearers forearms



NEO-SOVIET MILITARY Helmet 100eb (SP: 20)
Adjustable retracting monocle equipped with LL, Thermograph, and tele-optics and a built in short range radio. Similar, though inferior, to Militechs latest infantry helmet. The advanced version is a little more sloped, and has a built in camera and flash/laser light.



NIZZI Executive Armor 37,599EB (SP:20)(BOD+2)(MA:+2)
This flexible but highly durable armored body suit was created with Meticulously layered datafilm. It provides neck to toe protection in a design so thin and comfortable it can be worn under most clothes while being nearly as effective as Metal Gear. It also interweaves state of the art advanced muscle fibers into the suit, increasing the users strength and speed.

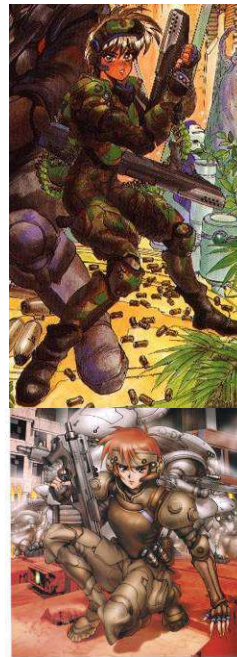

POSEIDON GASIU K-5 BATTLESUIT SP:18 EV-0 500-1500eb
An armored body suit usually custom compartmentalized for the wearer's specific needs (sown in holsters for specific weapons and pockets etc...). The K-5 is made to be worn with a datasuit underneath. Despite its bulk this suit is incredibly light and has no encumbrance penalty. It offers an SP of 18 from head to toe and is covered with a special rubberized coating to prevent clash and clatter. The suit will be custom fitted and compartmentalized to whatever the wearer's demands may be. This armor has become so popular that Poseidon has begun manufacturing it in a wide variety of colors and variations designed to suit any need. From urban to jungle to desert to arctic conditions this is the best armor on the market in terms of protection, comfort, and range of motion.



POSEIDON K-7 METAL GEAR SP:14 EV-0 2270eb
A lighter, more agile version of the Gasiu K-5 battlesuit. They even make it in sizes large enough to fit normally proportioned and shaped full conversions.



QUAKE CM-V6 Battle Armor 1100eb
This set of battle armor is only sold as a whole, it consists of helmet, adjustable torso clamshell armor with should and upper arm plates, belt with groin protection, thigh and knee pads, boots, and gauntlets (all rated SP:18). Accessories include holsters, pouches, and sheathes, and the helmet comes with built in radio, with space for 4 optic options for the visor. The suit is adjustable, and when done correctly to fit the user, it fits like a glove (no EV penalty).



ROSTOVIC
NKVBDA-5 1190eb
 SP:22 (Torso, limbs)
 SP:25 (head) EV-3
 This is the heavy combat Metal Gear supplied to Eastern European military forces and police. It is heavy, but offers more protection than it's standard US counterpart. The helmet comes equipped with short range radio, IR, AD, HUD, and enhanced audio pickup.



ROSTOVIC
ZNZR-Armor 12,540eb
 Supplied by Russia, these older suits of slightly powered metal gear aren't quite as powerful as the new Russian Deep Eyes suits, the Arasaka Orcs, or the Militech HAL-O5 suits, but they should not be underestimated. The boost the wearers strength (+2) and speed (+2) and provide all over protection (SP:22) with little negative effect to the wearers agility (EV-2).



ROSTOVIC
Deep-Eyes Armor 24,350eb
 (SP:28) (EV:2) (STR:+5)
 Russians utilize their advanced Metal Gear perhaps more than any other military on the planet. Comparable to the Arasaka ORC suits, or the Militech HAL-O5 armor, but offering even more protection this armor is heavy and cumbersome, but extremely effective. It also features a built in heater, to keep hypothermia from setting in during the cold Russian winters, and an AC unit (tech stolen from the EDF metal Gear) to keep their soldiers from killing themselves in the grueling heat of the deserts or jungles of the world. The helmet features Short Range Radio complete with level dampener, and the optics include Smart Link, Times Square, Ultraviolet, Thermoptics, Anti-Dazzle, and Tele-optics. The standard infantry (shown left) and Special Forces (shown right) version vary slightly in appearance. There is an advanced version in development, that offers true interface (dropping the EV to 0), thermal dampening, and boosts the wearers running speed (MA+2 35,000eb).



ROYAL ARMS
Advanced Combat Uniform 18,750eb
 Hard-shell body armor (SP:22), semi rigid leggings (SP:18), elbow pads (SP:8) and a high tech helmet (SP:25). The helmet features built in radio, laser communicator, flashlight with standard and UV settings, and an A/V recorder and transmitter (8 hours of record time). The visual suite of the helmet includes UV, Th, L-L, AD, TSM, and Smartlink, and the helmet is fully enclosed with an armored faceplate and visor (SP:10) with filter, can be seals around the wearers head and used as a gas mask. Finally the suit comes with an armored small backpack with a 20 minute independent air supply, in addition to standard storage space. The entire suit, which includes its own combat gloves, is thermal dampening, and acts like an IR poncho.



SABRETECH
WARHAMMER 450eb
 SP:25 (torso, head)
 SP:10 (legs, arms) EV-2
 The helmet of this combat armor comes equipped with radio, Low-light, and Anti-dazzle, as well as an air filter. The real nice touch however is the Sabretech Ammo-Hopper. Available to suit any caliber. Shown is the 2000 round 9mm attached to the Norinco Thunder assault cannon (rif - +1 - na - r - 2d6 (9mm) 2000 - 30 - st 895eb). Ammo capacity varies by ammunition size, for handgun rounds 2000, for assault rifle (4.5mm - 7.62) 300, for heavy rounds (10mm - 20mm) 100. The ammo hopper can be bought separate from the armor, and worn like any backpack at a cost of 200eb.



SOLDIERTECH
PCA-9 SP:14 (torso, legs, arms) SP:20 (head) EV-0 425eb
 This complete suit of armor is ideal for security personnel or even light assault work. Not as good as Gasium, but not as expensive either.



TRAUMA TEAM INTERNATIONAL / ARASAKA WADR-5 975eb
 This is the standard armor issued to medical members of a Trauma Team Extraction crew. The suit consists of a basic Trauma Team Jumpsuit, with a segmented hard armor clamshell torso covering (SP:18), a helmet (SP:10) with Audio/visual recorder transmitter linked to the teams AV and patched through to Trauma Team medical consultants who can offer advice on diagnosis and treatment, as well as tactical situations. The helmet is also equipped with Low Light, Thermograph, image enhancement, and micro-scope options. The gloves of the suit have built in defibrillators (can be used as tasers in an emergency) as well as built in mic tied in to the helmet to act as a stethoscope. The suit also comes with a wrist wearable micro-

computer with 2 detachable probe devices allowing the medic to instantly be able to monitor the clients vitals and make a preliminary tox screen. Finally there are numerous pouches and pockets for medical equipment, including two hardened pockets attached to the clamshell that hold trauma drugs. The suit comes with armored boots as well (SP:10). (This suit gives Trauma Team medics and first responders a +2 to diagnose illness and first aid checks.)

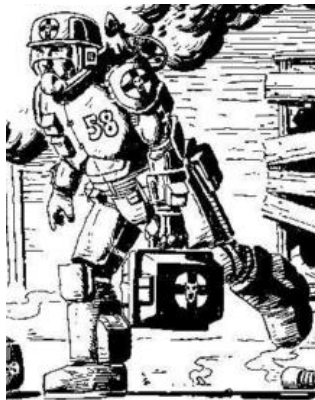

TRAUMA TEAM INTERNATIONAL WADR-7 2135eb SP:30 EV-4
 This is the armor worn by Trauma Team assault personnel and door gunners. Trauma Team got tired of having to pay insurance benefits to its employees who dropped into hot LZ's to extract the client. This armor allows them to shrug off any small arms fire without a sweat. Because this armor is so heavy and so bulky, only 2 operatives per AV will be wearing it.



UNITED STATES MILITARY M-3 Torso Armor 400eb (SP: 18)

Provides full protection for the torso as well as shoulders. This armor incorporates buckles for attaching load bearing straps directly to the armor, the straps attach at the shoulders and hook to the heavy belt of the soldier.



UNITED STATES MILITARY M-3G Groin Armor 40eb (SP: 10)
 Protects the soldiers groin, while somewhat uncomfortable, this is perhaps the most popular piece of armor among the soldiers, after all it protects the soldiers favorite piece of equipment.



UNITED STATES MILITARY M-3T Neck Armor 20eb (SP: 10)
 An armor plate gorget that protects the wearers throat, won't do much against most bullets, but will some protection is better than none, and will prevent garrote attacks effectively.



UNITED STATES MILITARY M-3L Shin/Knee Guard 50eb (SP: 10)
 Protects the wearers legs



**UNITED STATES
MILITARY**

**M-3H Helmet
290eb (SP: 20)**

Features separated plates on the back to protect the neck, and features a video camera w/ 2 hours recording time and detachable short range radio and a built in fold down optic with Low light and Thermograph installed. The radio headset is often worn even if the helmet isn't, providing the necessary communications in any situation.



**UNITED STATES
MILITARY**

**Superior Environmental
Combat Helmet
650eb (SP: 20)**

Featuring a full faceplate and visor equipped with Low Light, Thermograph, Image Enhancement, Time Square Marquee, UV, and Anti-dazzle, this system is state of the art. The helmet also features the same removable headset, and is equipped with Level Dampeners, video/audio recorder, and headlamp. An independent air supply, easily attachable to the standard torso mounting brackets completes the package. The helmet seals airtight around the wearers neck secure enough to dive 30 feet, a special collar allows greater depths to be reached and makes the helmet safe to wear in a vacuum. With less than six months since its introduction, supplies are limited and it is most often issued in situations wear gas or biological attack is expected.

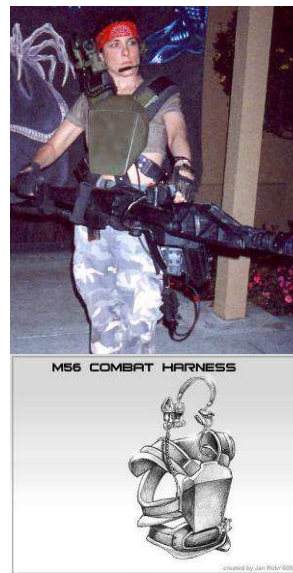

**UNITED STATES
MILITARY**

**M-HGR Heavy Gunners
Armor 210eb (SP: 20)**

This torso plate is actually built into the support for the gyro stabilization mount for the heavy machine gun. It doesn't cover as much area as the standard armor, and slightly more constraining, but it does offer a bit more protection for the areas it does cover with thicker, more rigid armor. The built in gyro-stabilization mount can accept virtually any heavy machine gun, but is most often used with the MILITECH M71B3HB or a Browning M2HB. Some soldiers have complained that in addition to carrying the big gun that makes them a target, the lesser protection is injury to insult.



**URBANTECH
RAVE ARMOR**

Rave armor from Urbantech isn't really that effective at stopping bullets, but it does help Street Samurai on a budget at least look like they have some protection. It really consists of nothing more than SP:10 shoulder pads which can be attached to any heavy leather jacket and sold for 230eb. The Rave boots, sold for 690eb a pair, on the other hand, also with an armor rating of SP:10, are well respected, since they protect the entire lower leg from the kneecaps down, front and back, with out sacrificing movement.

THE NOMAD MARKET

Clothing in the nomad community is much like everything else, often had made and always hard used. Usually leather or cotton, and heavily patched or resewn. Static society fashion means next to nothing to nomads, whose only idea of fashion is expressing themselves. Even among the cleanest nomads, clothes are usually well worn and frayed. It's a hard life being a nomad, their clothes reflect this. Rather than list individual prices of nomad clothing, we will instead be merely taking a look at typical outfits among the community, to give you an idea of what to look for when shopping yourself. Hundreds of vendors in the market sell both clothing and fabrics to make your own. Nomad crafted clothes however are in a class of their own, and the prices usually follow the same lines, 130eb for pants or chaps, 20eb for a shirt, 30eb for a thin jacket, 50eb for a thick jacket, 50eb for a duster or overcoat.

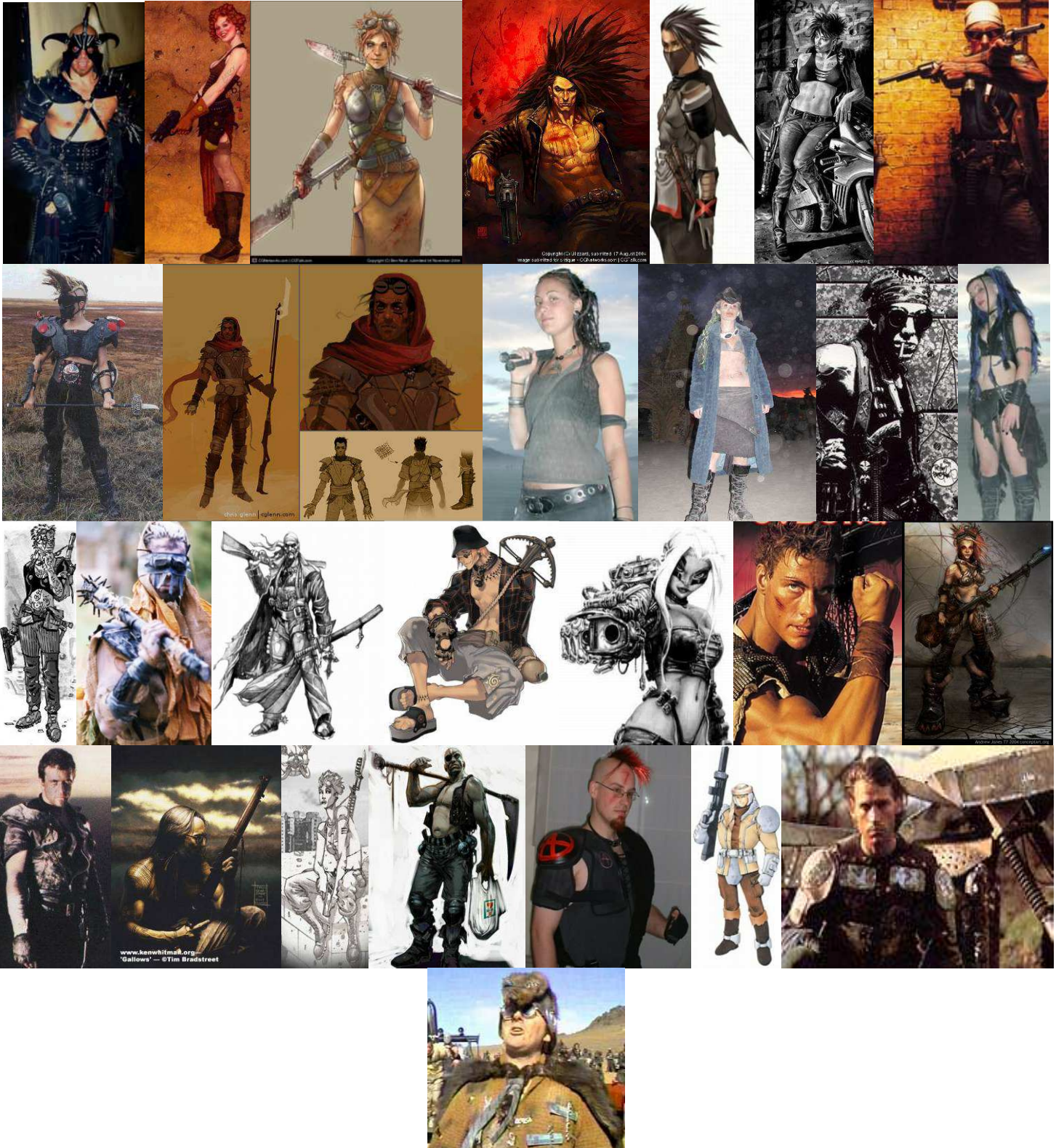

NOMAD ARMOR



Armor in the nomad community is like anything else, functional and usually made from whatever is lying around or cheap. Leather, old tires, sporting goods, scrap metal, chain mail, etc. Most nomads don't even wear armor unless absolutely necessary, comfort being a much more important issue. Some however, like the Raffen Shiv wear it constantly, both for protection, and as a sign of their clan allegiance. Nomad armor almost never looks the same, unless it is part of a standardized clan uniform, and even then there will be slight variations. The armor that is worn is more often than not as much for protection from the road as from attackers. Examples of the armor ratings of various nomad armor are as follows:

LIGHT ARMOR



Chainmail: (SP:10) usually only shirts or skirtings are made, as the weight is considered too detrimental. (cost for chainmail is 50 eb for shirt, 75 for shirt with sleeves, 75 for pants, 50 for skirt, and 25 for head dress). **DOES NOT PROTECT AGAINST BLUNT TRAUMA**, and armor piercing effects are doubled.



Heavy Leather: (SP:4) (Jackets 60eb, pants or chaps 50eb, shirts 35eb, Duster 125eb, etc. Very very durable, but gets hot quickly. It is recommended that if leather is the only armor you plan on wearing, you at least supplement it with steel plates.)



Banded Armor: (SP:8) (Smaller thinner plates of steel sown onto leather or cloth 75eb.)



Hand Gauntlets: SP:4) (Steel or tire rubber plates worn with a glove or by themselves, often spiked for an extra weapon d6/2 damage 20eb.)

HEAVY ARMOR



Football style shoulder pads: (SP:8) (Protect shoulders and upper torso, but leave belly exposed 30eb).



Motocross Armor: (SP:6) (separate pieces available for torso 50eb, belly 25eb, upper and lower arms 30eb, upper and lower legs 40eb)



Heavy Rubber Armor (SP:12) (Made from the tread of old tires, this actually protects a little better than steel pads, though it weighs much more and is only slightly more flexible. Available as either shoulder pads, or add on pads to an existing garment 50eb)



Steel Plates: (SP:10) (Often added to garments, like shoulder and elbow plates for a jacket, or knee pads for pants. Only protect a specific part of the body, if hit in that general location (torso for a shoulder plate as an example) Roll a ten sided again, 1-3 indicates the armored section took the hit. Additional armor cannot be worn over any garment with steel plates added 10eb.)



Sports Helmets: (SP:5 for baseball helmets to SP:8 for football helmets) (10-20eb) (Nomads really will use just about anything.)



Motorcycle Helmet: (SP:10) (45eb)



Steel Helmet: (SP:14) (These almost never protect the face, but come in a wide variety of styles 25eb)



SPIKED ARMOR 1eb per spike

Adding spikes to your armor generally won't help it's armor value, but in some cases, such as on gauntlets, gloves, boots, shin guards, knee or elbow pads, and sometimes even helmets, they will add an extra 3 points of damage to an attack. The other main benefit is that on clothing worn on the torso they make it difficult and painful for someone to attempt to grapple you. (-1 to -5 at GM's discretion based on number of spikes to all grapple checks against any portion of the opponents body that is spikes, for instance trying to head lock or bear hug someone wearing spiked shoulder pads. If the attacker succeeds, but by less than 3 points, the spikes do 1d6/2 points of damage).



A NOTE ON STEEL PLATE ARMOR

Most of the steel plating nomads use for armor comes from street signs (SP:10) or license plates (SP:6), which are plentiful, and if you don't have the skill or patience to incorporate it into your clothes or shape it, the signs themselves often make excellent shields. However, heavier steel can be used, a popular option being the grated heavier steel from industrial truck platforms. This weighs twice as much, but gives an SP of 20 (EV -1 for every approximate square foot worn) to any location it covers.



SPIKED STEEL SHIN.KNEE GUARD 265eb

Taken from a Raffin Shiv, these give front of the legs from knee to ankle, and can make for a brutal attack. (SP:12 EV-1, +1d6 knee damage).



ORNATE MASK/HELMET 675eb

Made of steel and featuring a built in air filter, this is a bit too heavy for most people to wear into battle (ev-2), but it is impressive and intimidating to look at (SP: 25).



TOWERING SHIELD 160eb

Designed by a nomad medic after a Raffen Shiv attack where he couldn't get to the wounded through the gunfire, this is really nothing more than heavy plate with view ports cut out and a pommel mount which accepts more handguns, smg's and light rifles. (SP 30, EV -3). Weighs 60 lbs.



TECHNOMANCER COLD WEATHER GEAR 1200eb

Able to withstand temperatures of below 30 Fahrenheit, this suit features a built in heated air filter, which not only warms the air you breath in, but protects from most of the common chemical and biological hazards. The suit itself also has a built in electrically powered heating unit (power is provided by walking).



TECHNOMANCER DESERT SURVIVAL GEAR 1160eb

Tired of the harsh desert sun, tired of not being able to wear armor without dying from the heat? Well this is your lucky day. This suit and helmet combo features a built in air conditioner with a 24 hour energy source rechargeable from any car cigarette lighter or wall outlet. The helmet features an SP rating of 20 and comes equipped with an air filter, radio, and a visual suite containing Low-Light, Thermograph, Anti-Dazzle, Tele-Optics, and Image-Enhancement. The suit itself is a heavy canvas with Kevlar woven in to provide a light armor with an SP: 8 rating all over the body. Buy it now and we will throw in the web gear, knife, canteen and shotgun as an added bonus.

Created and written by Deric Bernier, images from Deric Bernier, Appleseed, Cyberpunk 2077, Macross, Masamune Shirow, Gundam, Dirty Pair, Dark Minds, Men In Black, American Flag, Aliens: Colonial Marines, Deathwish, Deathstroke the Terminator, Starman, Kite, Space: Above and Beyond, Star Wars, Ice Pirates, Akira, Backlash, Babylon 5, Burn Up W, Dave Dorman, DS9, Dream Wave, Neon Cyber, Earth 2, Grendel: Devils Legacy, Hardboiled, Nausicaa, Secret Of Blue Water, Negative One, Punisher: Big Nothing, Runaway, L-gaim, Layzner, Ghost In The Shell, Catwoman, Titan AE, Wildcats, Stark Future, Total Recall 2070, Windaria, Rifts, Gurps, Trigun, Alien series, No Escape, Akira, Killzone, Firefly, Doom, Bubblegum Crash, Humanoid, Punishers Armory, Halo, Alien Legacy, The 5th Element, Time Cop, Shadowrun, Tomb Raider, Equilibrium, Intron Depot, Final Fantasy, Hellsing, Parasite Dolls, Bubblegum Crisis, Kappowwe Toys, Gungrave, AD Police, Bubblegum Crisis 2040, Grimjack, Project Snowblind, Bubblegum Crisis, S.I.N., Dirty Pair, Gundam, Doom, Gasaraki, Blue Gender, Hellboy, Blade series, Escape from New York, Escape from L.A., Eatman, G.I.T.S.: Stand Alone Complex, Jon Sable: Freelance, I Robot, Nomad, Mystery Men, D20 Future, D20 Apocalypse, Deadlands: Hell On Earth, Car Wars, Demolition Man, Fortress, Iria Zieriam, Natural City, Space, Above and Beyond, Stealth, Unreal Tournament, Moonwalker, Gunm, Southern Cross, Grifter, Battle Lords, Lensman, SeaQuest, Robocop, Aspen, Homeboys, Judge Dredd, Terminator: Burning Earth, Edison Giacotolli, Vortex, Soldier, Back To The Future II, Echo, Event Horizon, Starship Troopers, The Saint, Robotech: Sentinels, Deathlock, Hunter, Black Ops, James Bond, Death's Head, X-Men, Firearm, Nick Fury: Agent Of Shield, Dirty Pair: Flash, Silent Mobius, Mafia Wars, Army Of Two, Capcom, Hitman, Fatal Fury, Street Fighter, Deus Ex, Quake, Air Gear, Btoom, Tekken, Perfect Dark, Fallout, Bouncer, Frontlines, Crysis, District 9, Zatoichi, Bleach, Blame, The Rundown, Avengers, Green Arrow, GI-Joe, Call Of Duty, Brink, Doom, Eon Flux, Haze, Poseidon Arms, Nerf, Starhawk, Bayonetta, Bionic Six, Hudson Hawk, Avatar, Command And Conquer, Wastelands, Borderlands, and other various manga, Anime, Comic book, video game, film, and RPG sources, Raben-Aas, Sharp-n-pointy, Biometal79, Phatandy, Bordon, Shimmering Sword, Vulnepro, El Pinoy, Br0uHaHaasdsada, Larkabella, licataknives, meandmunch, Devilita Andree Wallin, Fuchsiart, imDRUNKonTEA, Guilty Spark, Refrigerador, Italiener, Pascal Eggert, Josh Nizzi, Bokuman, Machine56, Kunkka, Johan Bergstrom, Slipgate Central, Dominic Marko, Francis001, platypusgreen, jimmypham, Warrenlou, flipation, digimech, molybdenum, Spoonboy, Doll Fac3, Eikochan, bakanecone, teh dave, SC4V3NG3R, solkee, molinaro, KaranaK, genekruger, theelphin, garanum, 2ngaw, shed2602, gorrem, moyachiche, inception08, vietnguyen, rgus, archie, David Nakey, Kuroitora, aerpenium, Dead Robot, teruchan, acidburn08, Markovah, Mort Janu, MishaMoStyle, Blitz Bot, k hos, James Lemay, Gun0runner, Gneocidal Penguin, Kalor, ionen, djake, jett0, cyzrauk8, windridex23, firestoned, anjinanhut, regis, libertyspikesv5, rimancreative, deutscherherbst, hexonal, Ryujiin10, Raverunner, daisukekazama, dannortonart, bringmeasunkist, Merkaba998, tovenius, Message2god, peterku, nervousgryphon, knightwatch, Brian Rogers, tsukijin, talros, Michael Kingery, ygolochysp, Swatninja, Cyber999, marcwf, WarmGunMod, bcjfla76, bullseye breon, Carlo Arellano, Special thanks to Matsuo, Darth Brass, darcjedi, Tom_Braider, thedap, wuher_da_brewer, Capt_MarVel, Glim999, Pulseriflefan, TK513, gunnerk19, Tommin, BritNerfMogul, Tigadee, Johnson Arms, Wolverine_solo, and all the many fine prop replica builders of Mastucorp, the RPE, Nerfhaven, Nerfhq, and BBC)

For more of the best Cyberpunk 2020 goodness available, go to

**DATAFORTRESS
2.0.2.0**

<http://datafortress2020.oliwy.net/>

To e-mail the author:

droc@mc2k.com

